



US009859202B2

(12) **United States Patent**
Hu

(10) **Patent No.:** **US 9,859,202 B2**
(45) **Date of Patent:** **Jan. 2, 2018**

(54) **SPACER CONNECTOR**
(71) Applicant: **Dyi-Chung Hu**, Hsinchu (TW)
(72) Inventor: **Dyi-Chung Hu**, Hsinchu (TW)
(*) Notice: Subject to any disclaimer, the term of this patent is extended or adjusted under 35 U.S.C. 154(b) by 0 days.

21/56; H01L 21/60; H01L 23/00; H01L 23/02; H01L 23/12; H01L 23/14; H01L 23/28; H01L 23/31; H01L 23/48; H01L 23/52
USPC 174/262, 251, 252, 255, 258, 260, 261, 174/265; 257/675, 676, 686, 741, 758, 257/774, 777, 778, 787; 361/306.3, 752, 361/760, 773, 783; 29/830, 841
See application file for complete search history.

(21) Appl. No.: **15/190,695**

(56) **References Cited**

(22) Filed: **Jun. 23, 2016**

U.S. PATENT DOCUMENTS

(65) **Prior Publication Data**
US 2016/0379922 A1 Dec. 29, 2016

6,366,467	B1 *	4/2002	Patel	H05K 1/141 257/691
9,202,742	B1 *	12/2015	Kim	H01L 23/49827
9,376,541	B2 *	6/2016	Kang	C08K 3/08
2002/0179331	A1 *	12/2002	Brodsky	H05K 3/325 174/262
2003/0160325	A1 *	8/2003	Yoneda	H01L 21/4846 257/758
2004/0017672	A1 *	1/2004	Matsuda	H01L 23/13 361/767
2004/0173891	A1 *	9/2004	Imai	H01L 23/49827 257/686
2004/0178508	A1 *	9/2004	Nishimura	H01L 23/3128 257/778

Related U.S. Application Data

(60) Provisional application No. 62/184,034, filed on Jun. 24, 2015.

(51) **Int. Cl.**
H05K 1/11 (2006.01)
H01L 23/498 (2006.01)
H01L 21/48 (2006.01)
H01L 25/10 (2006.01)

(Continued)

Primary Examiner — Xiaoliang Chen
(74) *Attorney, Agent, or Firm* — JCIPRNET

(52) **U.S. Cl.**
CPC **H01L 23/49838** (2013.01); **H01L 21/486** (2013.01); **H01L 21/4846** (2013.01); **H01L 23/49827** (2013.01); **H01L 25/105** (2013.01); **H01L 2224/16227** (2013.01); **H01L 2225/107** (2013.01); **H01L 2225/1023** (2013.01); **H01L 2924/15313** (2013.01); **H01L 2924/15331** (2013.01)

(57) **ABSTRACT**
A fabricating process for a spacer connector is disclosed. A core substrate with a plurality of through holes is prepared. A conductive carrier with a dielectric adhesive configured on a top surface is prepared. The core substrate is then pasted on a top surface of the dielectric adhesive layer. The dielectric adhesive exposed in the through hole is then etched. An electric plating process to form metal pillar in the core substrate is performed using the conductive carrier as one of the electrode.

(58) **Field of Classification Search**
CPC .. H05K 1/02; H05K 1/03; H05K 1/09; H05K 1/11; H05K 1/14; H05K 1/16; H05K 1/18; H05K 3/00; H05K 3/30; H05K 3/32; H05K 3/36; H05K 3/40; H01L 21/02; H01L 21/48; H01L 21/50; H01L

9 Claims, 14 Drawing Sheets

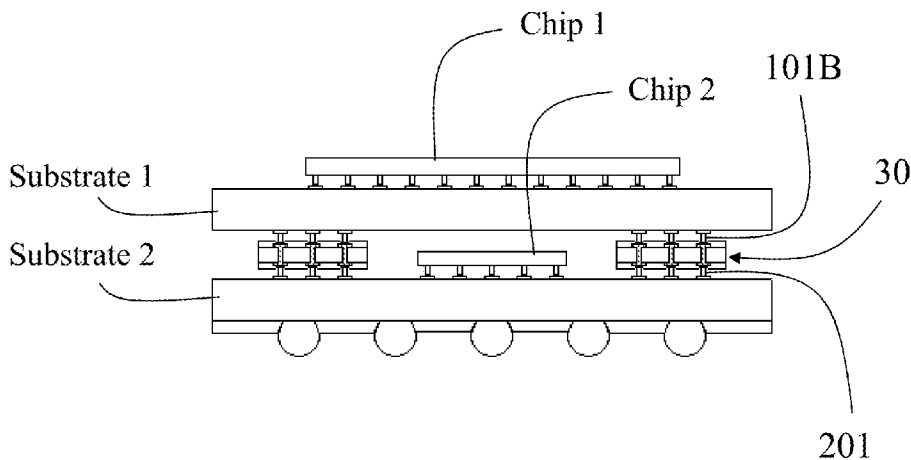

(56)

References Cited

U.S. PATENT DOCUMENTS

2004/0184219	A1 *	9/2004	Otsuka	H01L 23/49805	361/306.3	2012/0326334	A1 *	12/2012	Sakaguchi	H01L 23/147	257/778
2004/0227258	A1 *	11/2004	Nakatani	H01L 23/49805	257/787	2013/0001798	A1 *	1/2013	Choi	H01L 23/481	257/774
2005/0184381	A1 *	8/2005	Asahi	H01R 13/2414	257/693	2013/0027895	A1 *	1/2013	Hayashi	H01L 23/145	361/760
2005/0194672	A1 *	9/2005	Gibson	H05K 1/112	257/686	2013/0037964	A1 *	2/2013	Lee	H01L 23/481	257/774
2006/0055017	A1 *	3/2006	Cho	H01L 25/105	257/686	2013/0111123	A1 *	5/2013	Thayer	G06F 13/16	711/105
2006/0091538	A1 *	5/2006	Kabadi	H05K 7/1061	257/737	2013/0147026	A1 *	6/2013	Topacio	H01L 25/105	257/698
2006/0180938	A1 *	8/2006	Kurihara	H01L 21/4853	257/773	2013/0320568	A1 *	12/2013	Aoki	H01L 24/09	257/777
2007/0057685	A1 *	3/2007	Garabedian	G01R 1/07371	324/754.18	2014/0001639	A1 *	1/2014	Hiraishi	H01L 23/48	257/773
2007/0075717	A1 *	4/2007	Kinghorn	G01R 1/07378	324/754.18	2014/0085850	A1 *	3/2014	Li	H05K 1/0231	361/773
2007/0090534	A1 *	4/2007	Iwasaki	H01L 23/5385	257/777	2014/0092569	A1 *	4/2014	Sakurai	H05K 3/4697	361/752
2007/0215380	A1 *	9/2007	Shibamoto	H01L 23/3128	174/260	2014/0117557	A1 *	5/2014	Chen	H01L 23/49822	257/774
2008/0155820	A1 *	7/2008	Arai	H01L 21/565	29/830	2014/0157593	A1 *	6/2014	Lin	H01L 24/19	29/832
2008/0157326	A1 *	7/2008	Han	H05K 3/3436	257/686	2014/0167263	A1 *	6/2014	Wu	H01L 21/565	257/741
2009/0108425	A1 *	4/2009	Lee	H01L 23/3128	257/679	2014/0252561	A1 *	9/2014	Lisk	H01L 23/5384	257/621
2009/0145636	A1 *	6/2009	Miki	H01L 21/6835	174/255	2015/0061095	A1 *	3/2015	Choi	H01L 24/20	257/675
2010/0025081	A1 *	2/2010	Arai	H01L 21/4857	174/251	2015/0061101	A1 *	3/2015	Le	H01L 25/0655	257/676
2011/0080713	A1 *	4/2011	Sunohara	H01L 23/147	361/760	2015/0102485	A1 *	4/2015	Kang	C08K 3/08	257/737
2012/0119370	A1 *	5/2012	Yoo	H01L 23/15	257/773	2015/0115466	A1 *	4/2015	Kim	H01L 23/49811	257/774
2012/0147578	A1 *	6/2012	Jin	H01F 19/04	361/774	2015/0115467	A1 *	4/2015	Park	H05K 1/141	257/774
2012/0193812	A1 *	8/2012	Toh	H01L 21/561	257/774	2015/0214207	A1 *	7/2015	Yoshida	H01L 25/0657	438/109
2012/0211885	A1 *	8/2012	Choi	H01L 23/3128	257/737	2015/0255412	A1 *	9/2015	Meyer	G06F 1/1613	361/679.55
							2016/0027712	A1 *	1/2016	Hu	H01L 23/49833	174/262
							2016/0027764	A1 *	1/2016	Kim	H01L 24/97	257/686

* cited by examiner

Fig.1A

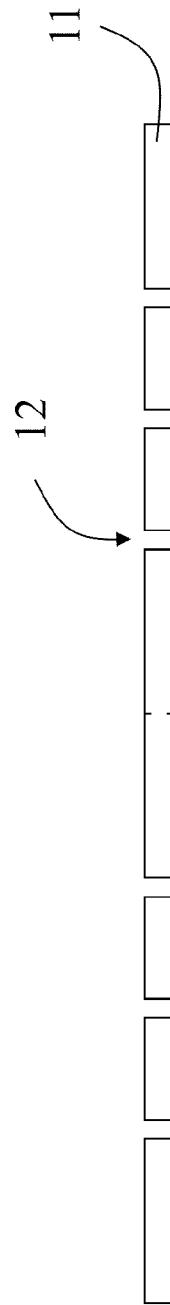
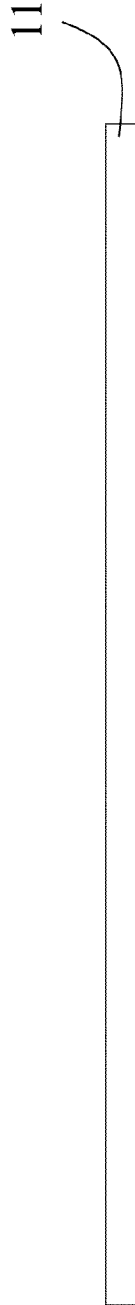

Fig.1B

Fig.2

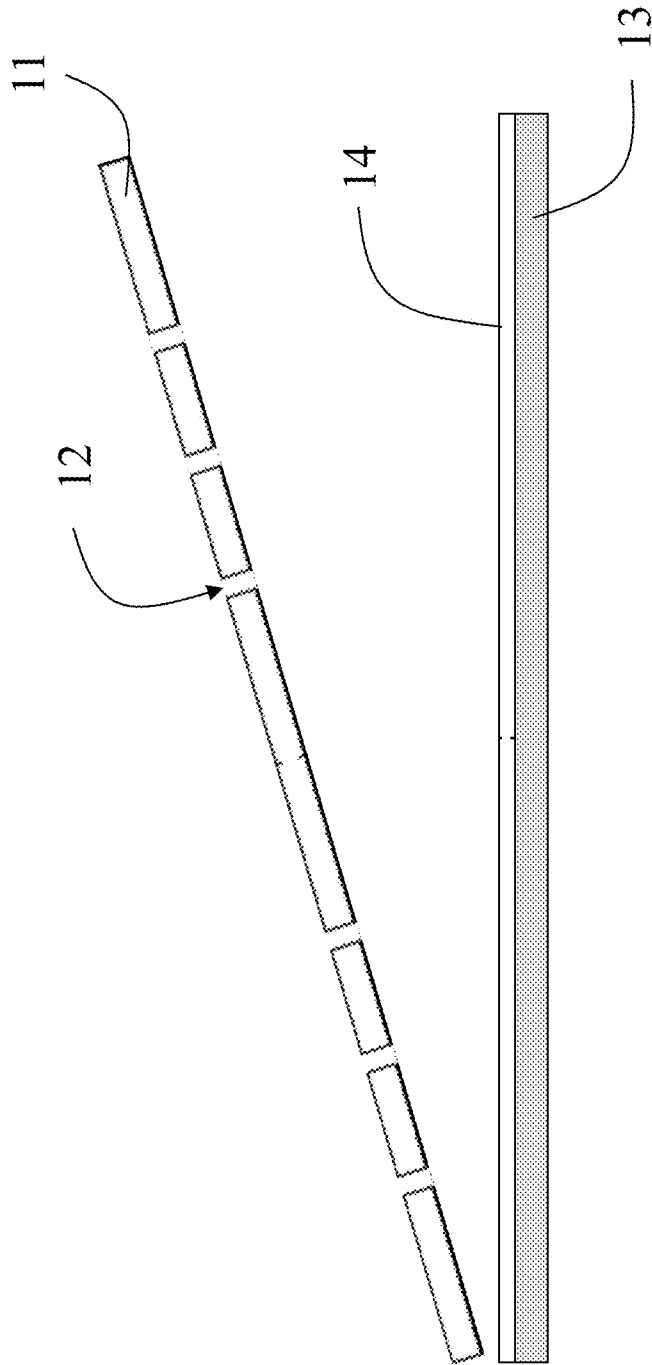

Fig.3A

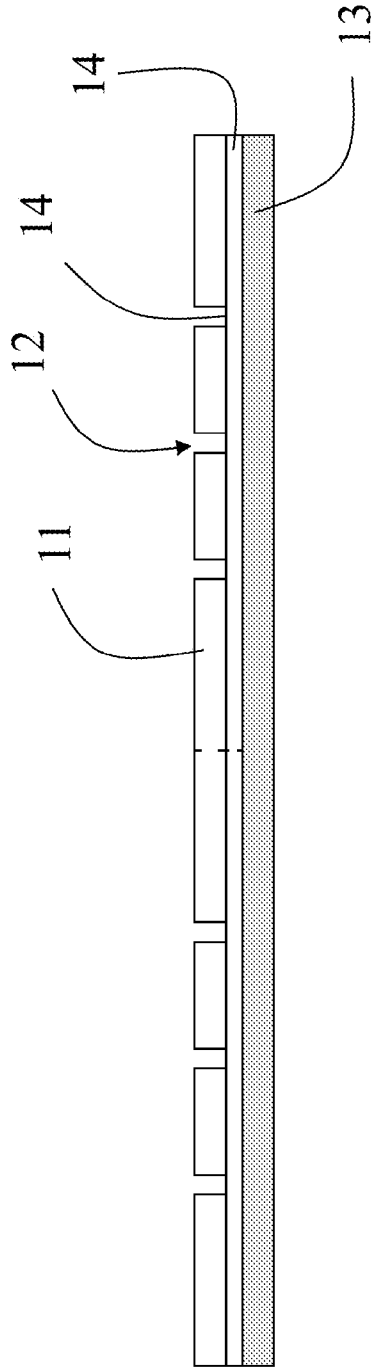

Fig.3B

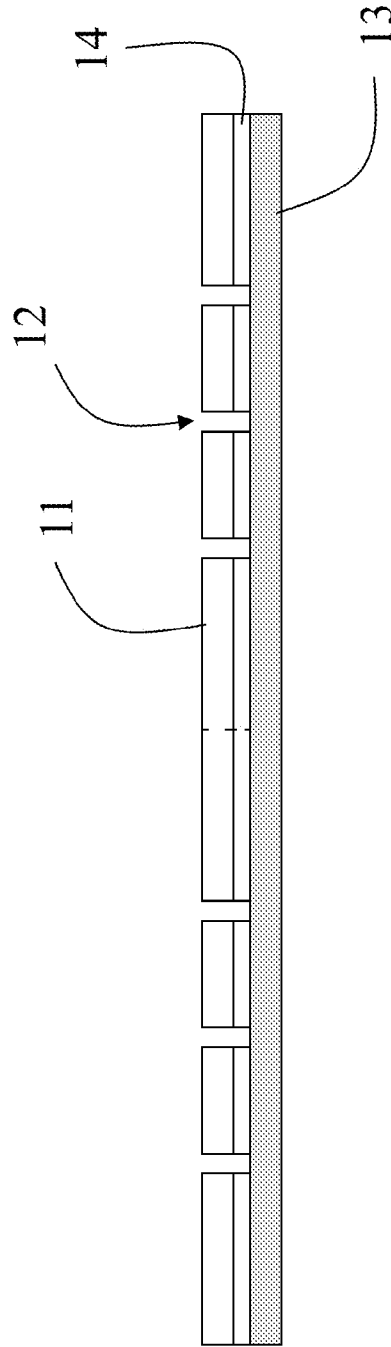

Fig.4A

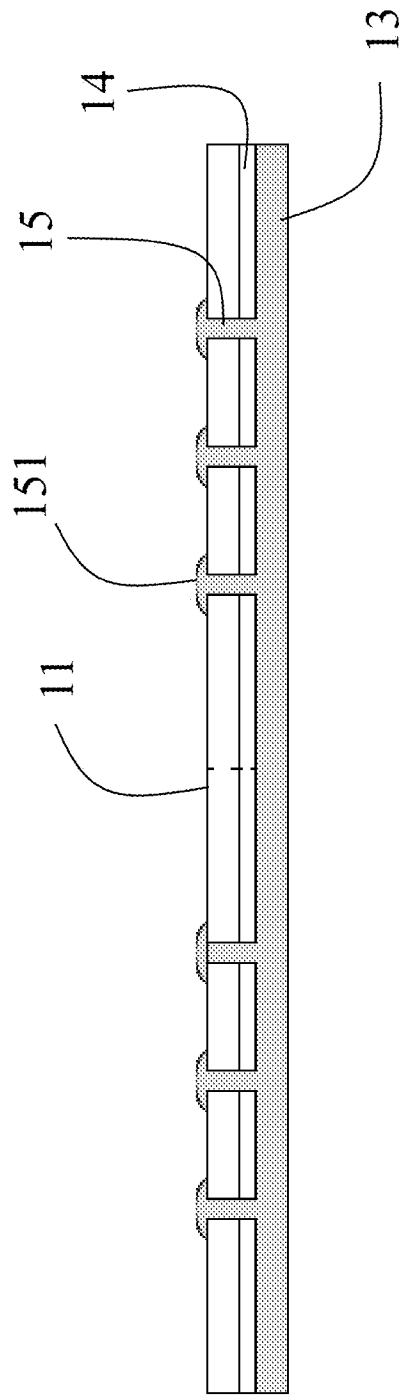

Fig.4B

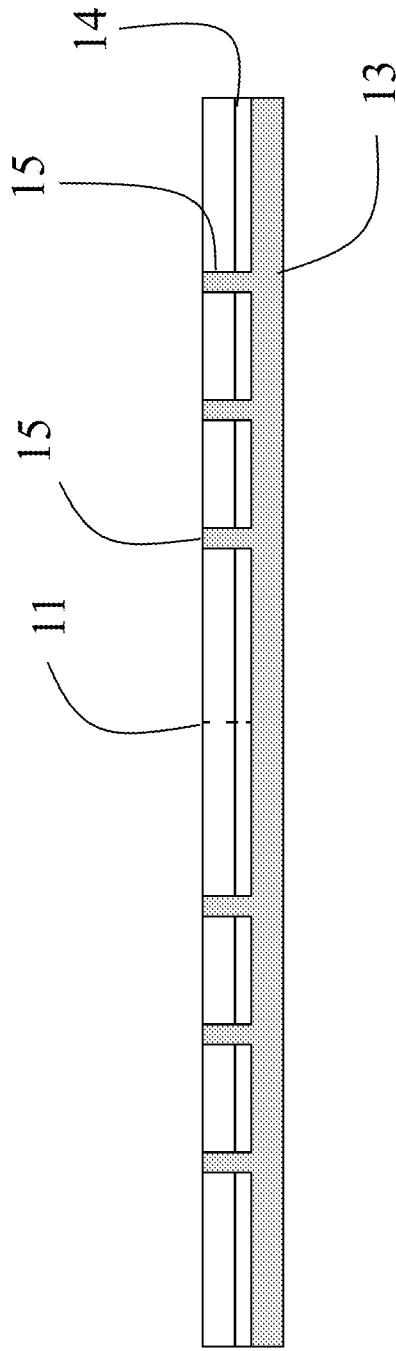

Fig.5A

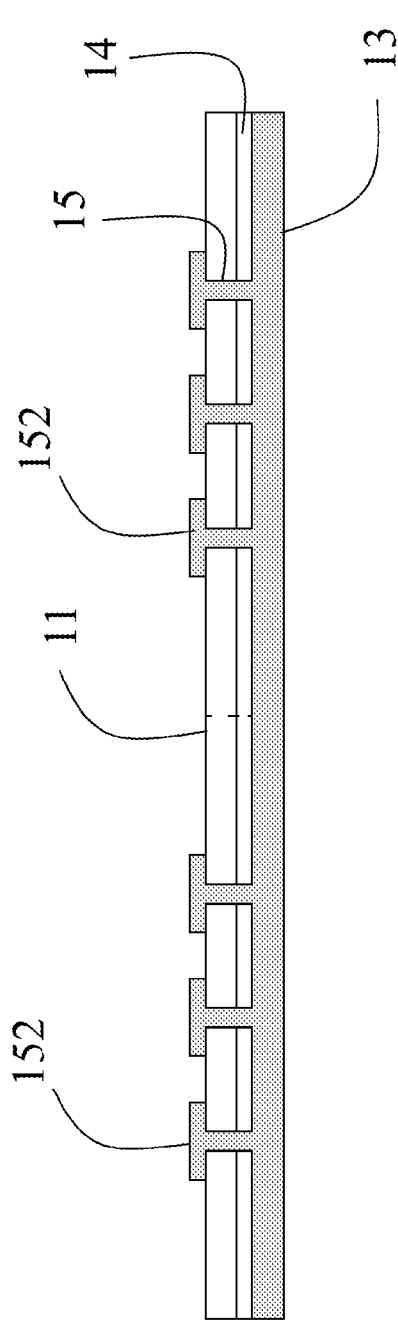

Fig.5B

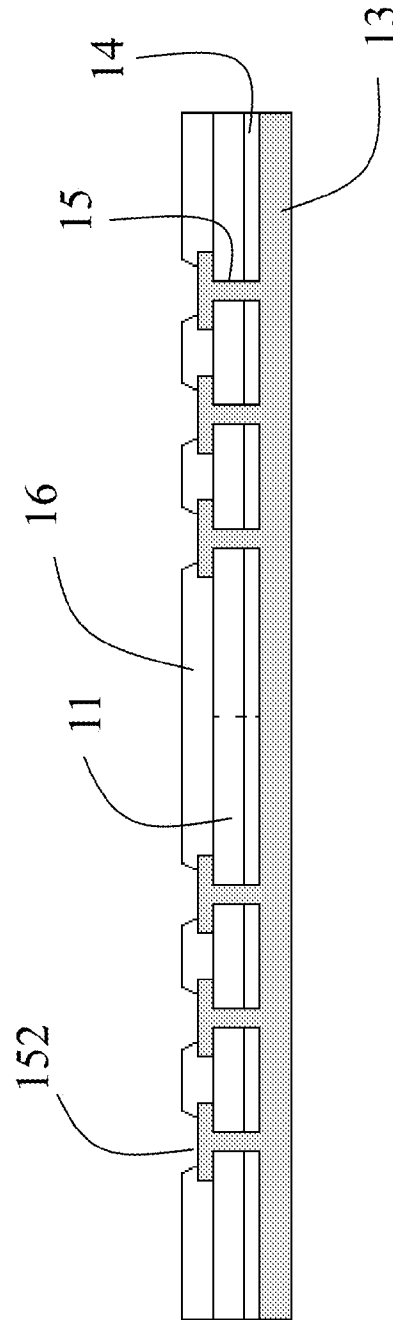

Fig.6A

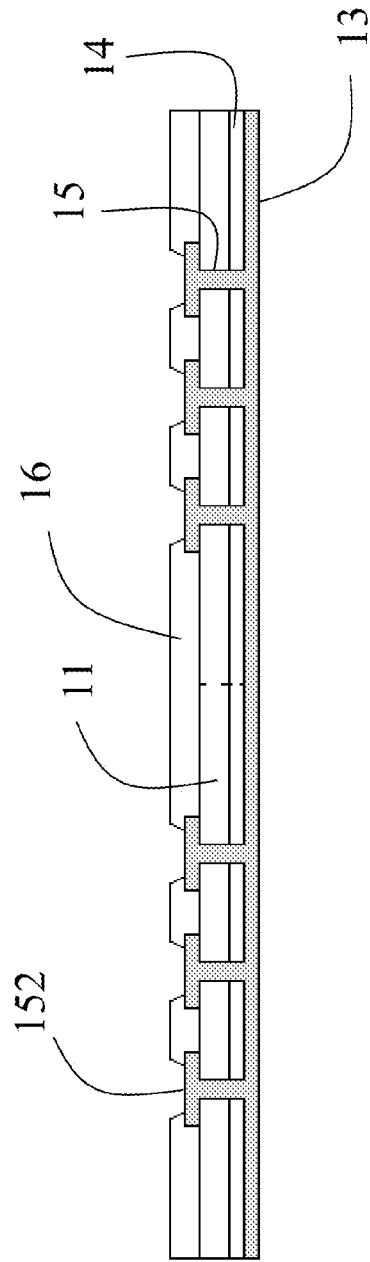

Fig.6B

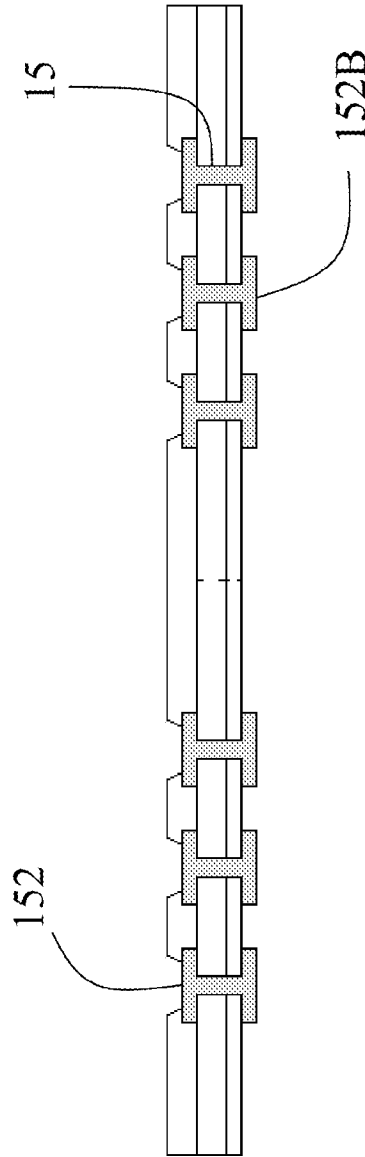

Fig.7A

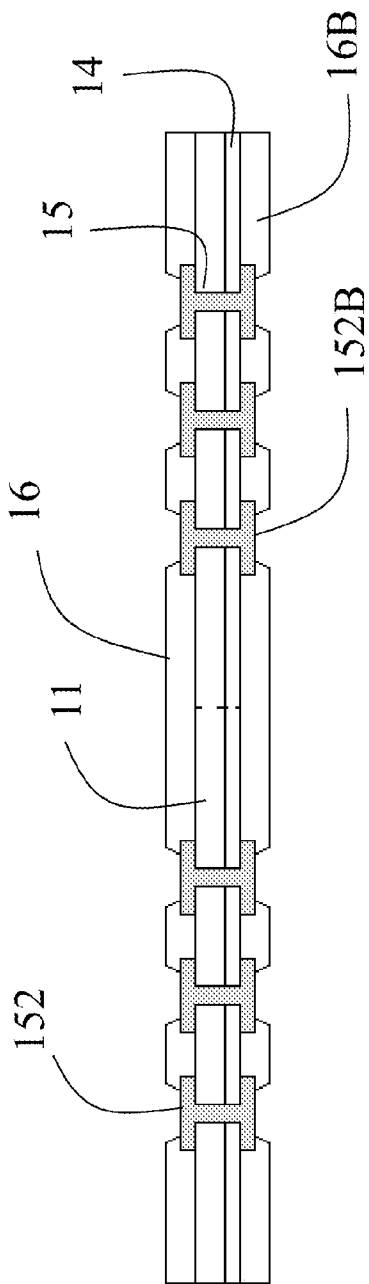

Fig.7B

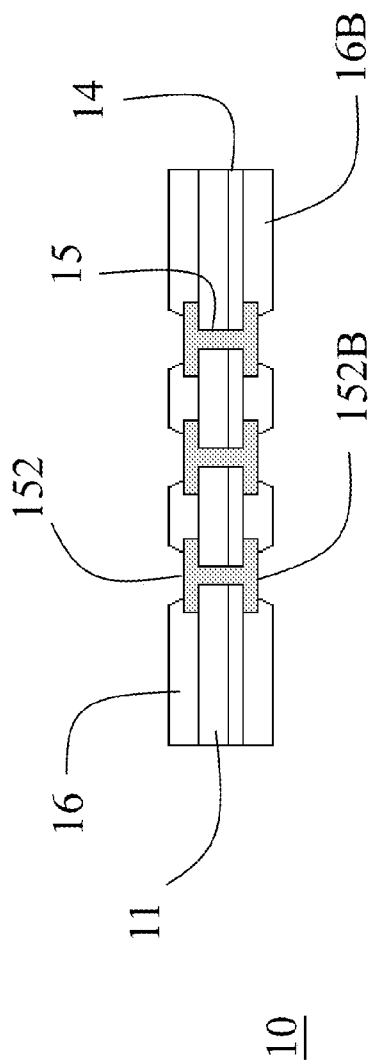

Fig.8

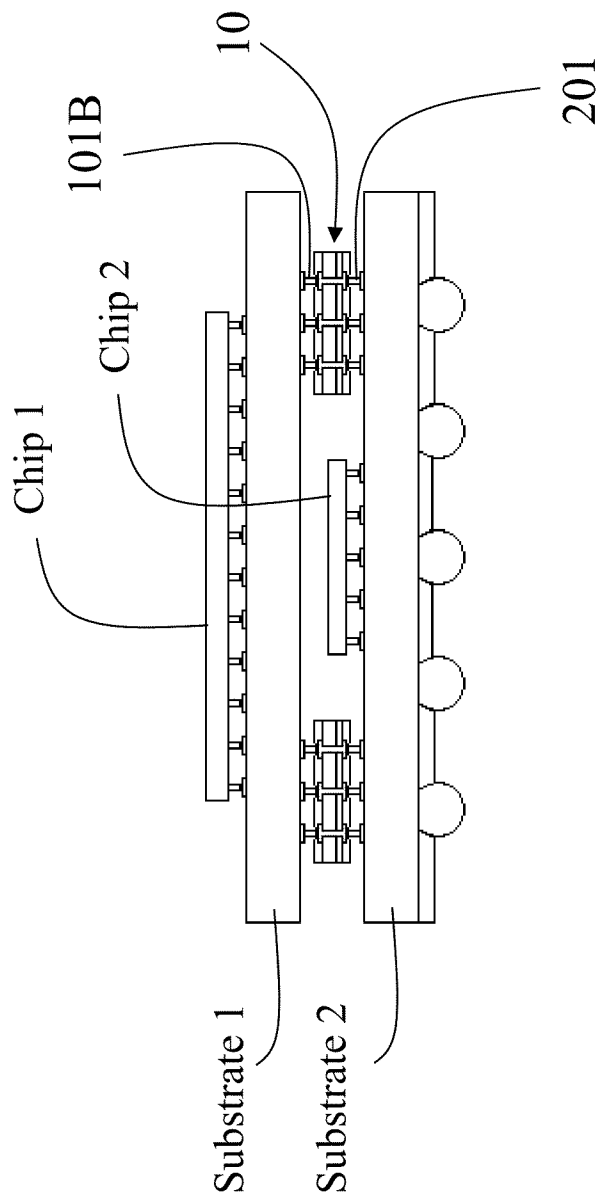

Fig.9A

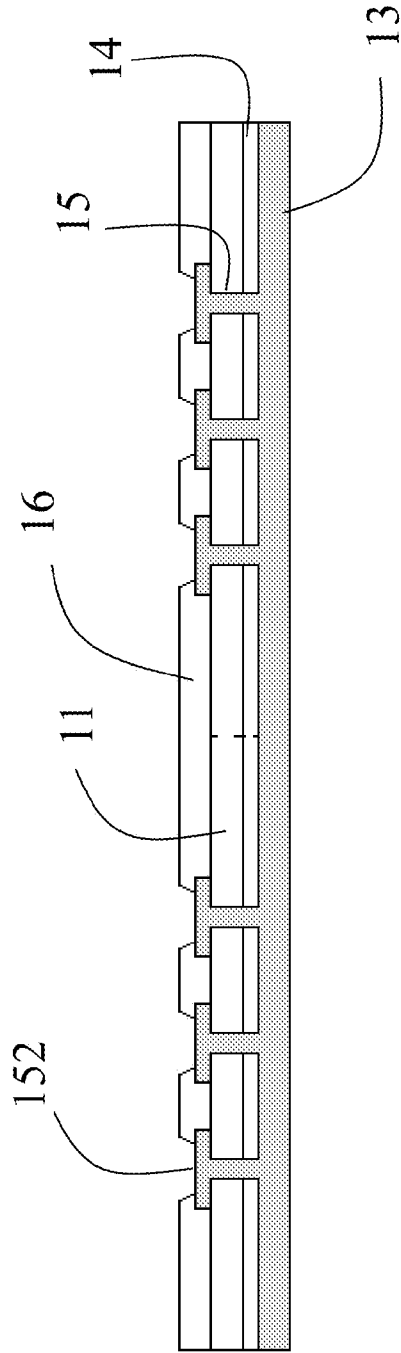

Fig.9B

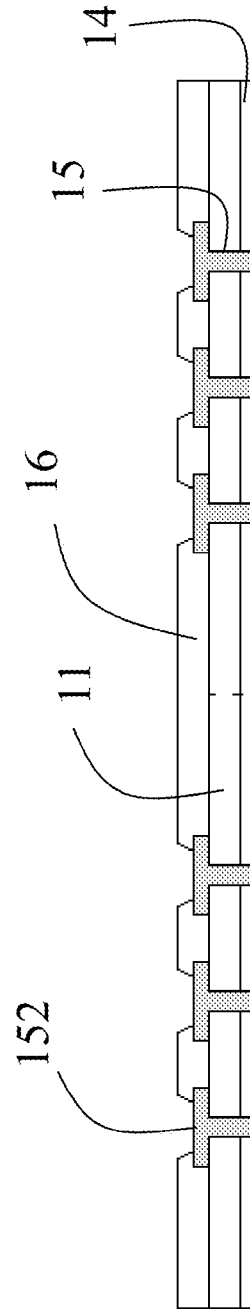

Fig.10A

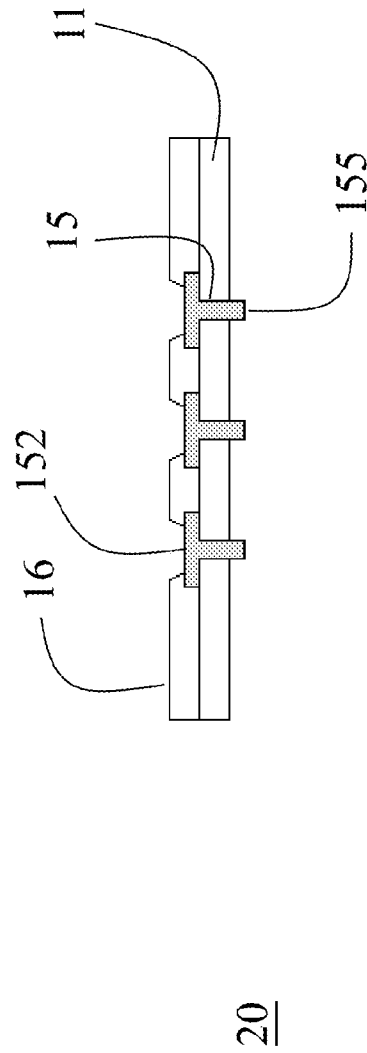
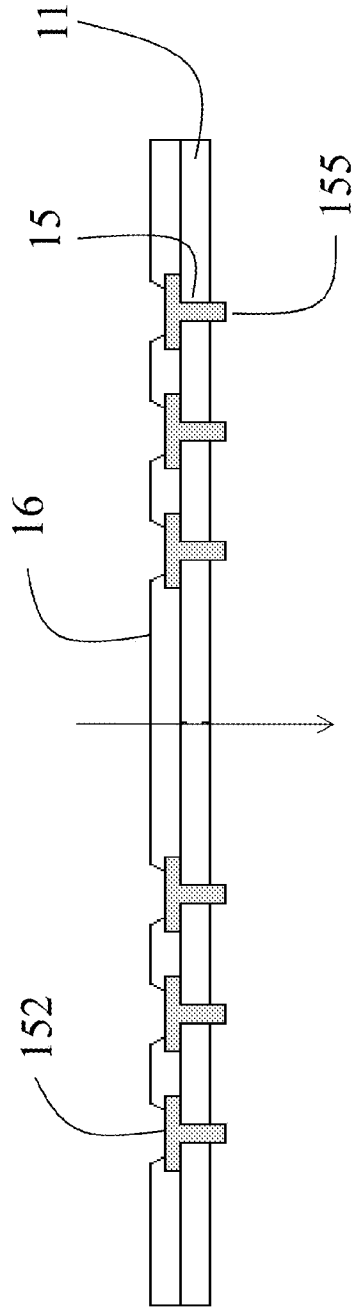

Fig.10B

Fig.11

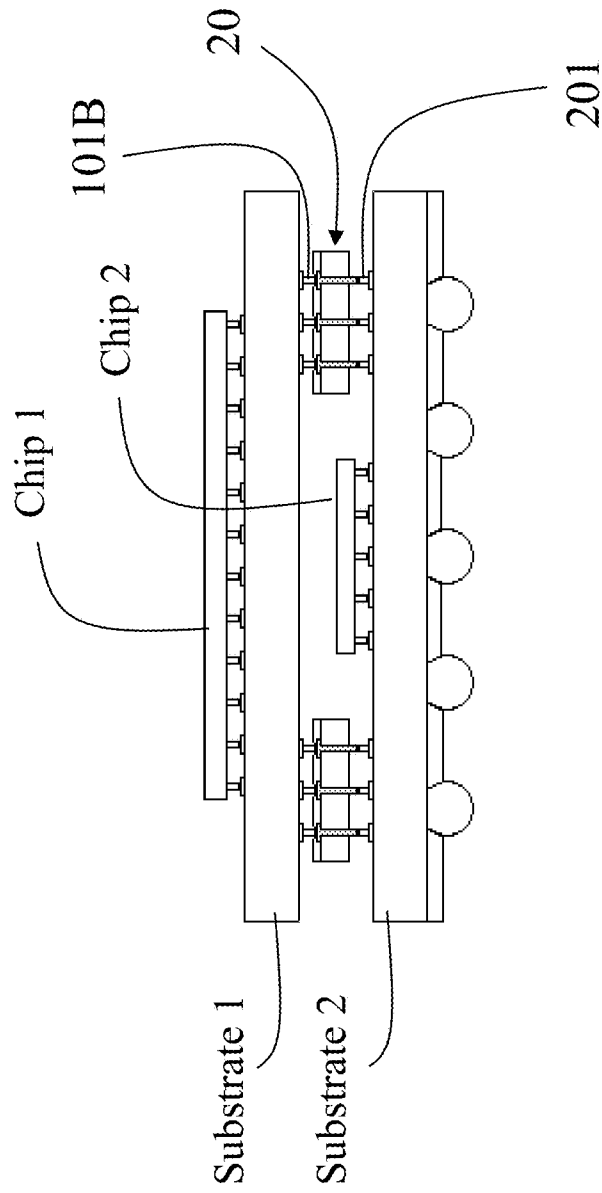

Fig.12A

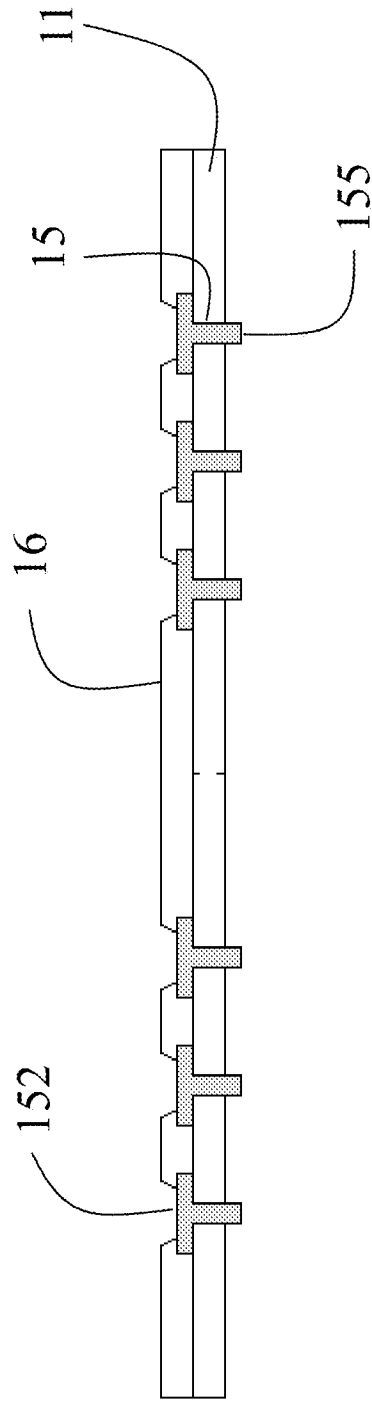

Fig.12B

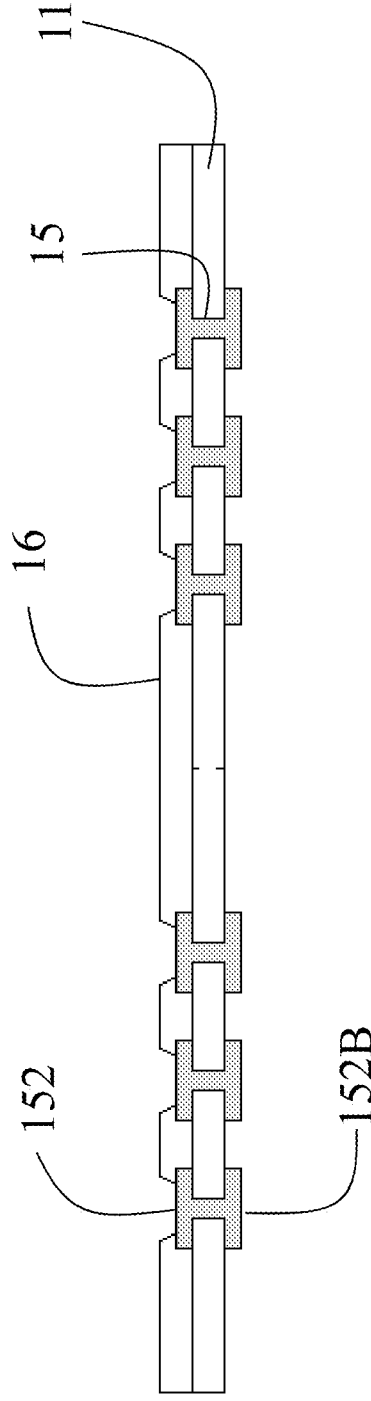
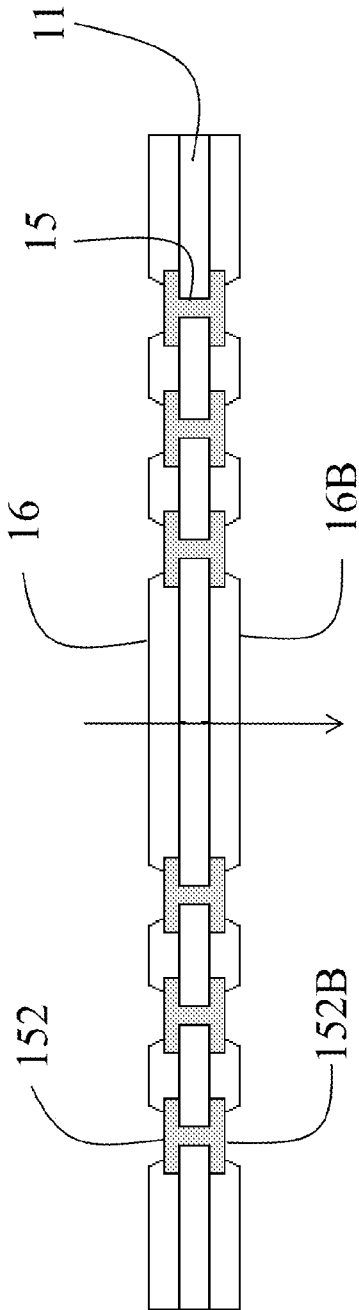

Fig.13A



30

Fig.13B

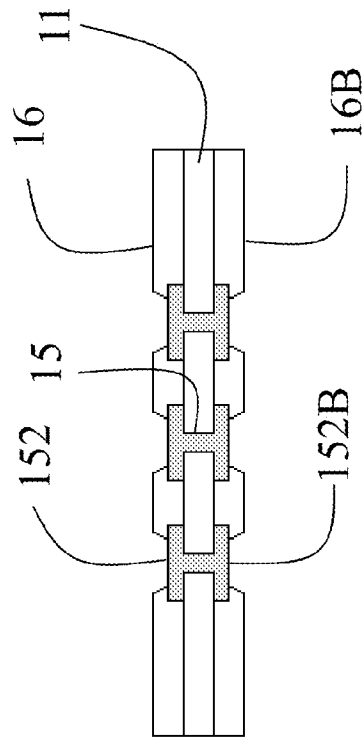
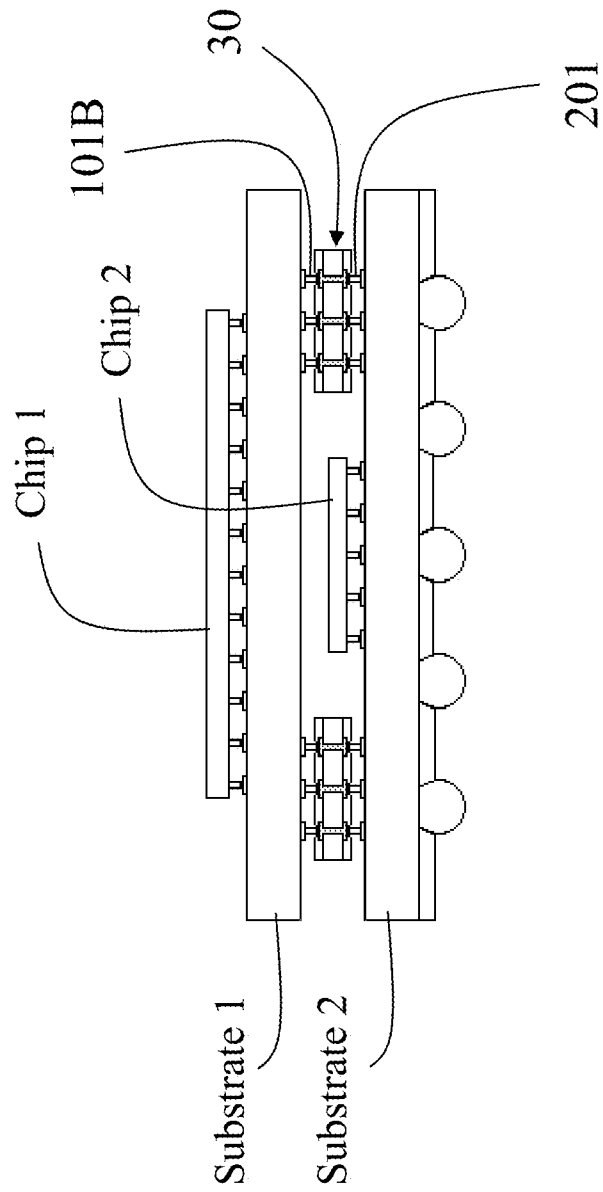

Fig.14



1

SPACER CONNECTOR

RELATED APPLICATIONS

The present application claims the benefit of U.S. Provisional Application No. 62/184,034, filed Jun. 24, 2015, the disclosure of which is hereby incorporated by reference herein in its entirety.

BACKGROUND

Technical Field

The present invention relates to a fabricating process for making a spacer connector, especially using a conductive carrier in an initial step of the fabrication process.

Description of Related Art

One of the traditional processes for fabricating metal circuitry, a seed layer is often applied before electric plating. In a later process, the seed layer needs to be stripped. However, the stripping of the seed layer reduces the size of the circuits. Although such a circuit reduction is tiny, it is critical when it comes to nanotechnology. A fabricating process without reducing the dimension of a circuitry is one of the popular topics to study for a long time in the semiconductor industry.

BRIEF DESCRIPTION OF THE DRAWINGS

FIGS. 1A~7A show a fabricating process for a first embodiment according the present invention.

FIG. 7B shows a first embodiment according to the present invention.

FIG. 8 shows an application for the first spacer connector according to the present invention.

FIGS. 9A~10A show some steps in a fabricating process for a second embodiment according the present invention.

FIG. 10B shows a second embodiment according to the present invention.

FIG. 11 shows an application for the second spacer connector according to the present invention.

FIGS. 12A~13A show some steps in a fabricating process for a third embodiment according the present invention.

FIG. 13B shows a third embodiment according to the present invention.

FIG. 14 shows an application for the third spacer connector according to the present invention.

DETAILED DESCRIPTION OF THE INVENTION

A fabricating process for making a spacer connector without using seed layer is disclosed.

FIGS. 1A~7A show a fabricating process for a first embodiment according the present invention.

FIG. 1A shows that a core substrate **11** is prepared. The core substrate **11** is made of a material of glass or silicon.

FIG. 1B shows a plurality of openings **12** is made through the core substrate **11**.

FIG. 2 shows a temporary conductive carrier **13** is prepared. A dielectric adhesive **14** is applied on a top surface of the conductive carrier **13**. The core substrate **11** with through holes **12** is pasted onto the dielectric adhesive **14**.

FIG. 3A shows that the core substrate **11** is configured on a top surface of the dielectric adhesive **14**.

FIG. 3B shows that the dielectric adhesive **14** on a bottom of each through holes **12** is etched, and a top surface of the conductive carrier **13** is exposed.

2

FIG. 4A shows copper plating is performed using the conductive carrier **13** as one of the electrode. Copper pillar **15** is formed starting from the exposed conductive carrier in each through holes **12**. A metal head **151** is configured on a top of the copper pillar **15**.

FIG. 4B shows the metal heads **151** are removed.

FIG. 5A shows that top metal pad **152** is formed.

FIG. 5B shows that a passivation **16** is formed on a top of the core substrate **11**. The passivation **16** also covers peripheral area of each top metal pad **152** and a central portion of the top metal pad **152** is exposed for electrical connection.

FIG. 6A shows thinning process is performed from a bottom the temporary conductive carrier **13**.

FIG. 6B show etching process is performed to the conductive carrier **13** to form a plurality of bottom metal pads **152B**. Each of the bottom metal pads **152B** is configured on a bottom of a corresponding metal pillar **15**.

FIG. 7A shows a bottom passivation **16B** is formed on a bottom surface of the dielectric adhesive **14**. The bottom passivation **16B** also covers peripheral area of each bottom metal pad **152B** and a central portion of the bottom metal pad **152B** is exposed for electrical connection.

FIG. 7B shows a first embodiment according to the present invention.

FIG. 7B shows a first embodiment of the spacer connector **10** is produced after a singulation process performed on a product of FIG. 7A.

FIG. 8 shows an application for the first spacer connector according to the present invention.

FIG. 8 shows two spacer connectors **10** are configured in between package substrate **1** and package substrate **2**. FIG. 8 shows chip **1** is configured on a top center of package substrate **1**. Chip **2** is configured on a top center of package substrate **2**. Package substrate **1** is stacked on a top of package substrate **2**.

The package substrate **1** has a plurality of bottom metal pillars **101B**, each metal pillar **101B** is electrically coupled to a corresponding top metal pad **152** of the spacer connector **10**. The package substrate **2** has a plurality of top metal pillars **201**, each metal pillar **201** is electrically coupled to a corresponding bottom metal pad **152B** of the spacer connector **10**.

FIGS. 1A~5B, 9A~10A show a fabricating process for a second embodiment according the present invention.

FIGS. 1A~5B have been described in previous paragraphs and are omitted for simplification.

FIG. 9A is the same of the product of FIG. 5B which is a product prepared according to process FIGS. 1A~5A.

FIG. 9B shows the conductive carrier **13** is stripped. The dielectric adhesive **14** is revealed.

FIG. 10A shows the dielectric adhesive **14** is stripped. A bottom end **155** of the copper pillar **15** protruded below a bottom surface of the core substrate **11**.

FIG. 10B shows a second embodiment according to the present invention.

FIG. 10B shows a second embodiment of the spacer connector **20** is produced after a singulation process is performed on the product of FIG. 10A.

FIG. 11 shows an application for the second spacer connector according to the present invention.

FIG. 11 shows two spacer connectors **20** are configured in between substrate **1** and substrate **2**. FIG. 11 shows chip **1** is configured on a top center of substrate **1**. Chip **2** is configured on a top center of substrate **2**. Substrate **1** is stacked on a top of substrate **2**.

FIGS. 1A~5B, 12A~13A show a fabricating process for a third embodiment according the present invention.

3

FIGS. 1A-5B have been described in previous paragraphs and are omitted for simplification.

FIG. 12A is the same of the product of FIG. 10A.

FIG. 12B shows a plurality of bottom metal pads 152B is formed. Each bottom metal pads 152B is configured on a bottom of a corresponding copper pillar 15.

FIG. 13A shows a bottom passivation 16B is formed on a bottom surface of the core substrate 11. The bottom passivation 16B also covers peripheral area of each bottom metal pad 152B and a central portion of the bottom metal pad 152B is exposed for electrical connection.

FIG. 13B shows a third embodiment according to the present invention.

FIG. 13B shows a second embodiment of the spacer connector 30 is produced after a singulation process is performed on the product of FIG. 13A.

FIG. 14 shows an application for the third spacer connector according to the present invention.

FIG. 14 shows two spacer connectors 30 are configured in between substrate 1 and substrate 2. FIG. 11 shows chip 1 is configured on a top center of substrate 1. Chip 2 is configured on a top center of substrate 2. Substrate 1 is stacked on a top of substrate 2.

While several embodiments have been described by way of example, it will be apparent to those skilled in the art that various modifications may be configured without departs from the spirit of the present invention. Such modifications are all within the scope of the present invention, as defined by the appended claims.

What is claimed is:

1. A structure, comprising:

a bottom package substrate;

a top package substrate stacked on top of the bottom package substrate;

at least one spacer connector interposed between the bottom package substrate and the top package substrate to define a space between the bottom package substrate and the top package substrate, wherein

the spacer connector comprises

a core substrate;

a plurality of metal pillars, each passing through the core substrate; and

a plurality of top metal pads, each on a top end of a corresponding metal pillar among the plurality of metal pillars;

wherein a bottom end of each metal pillar among the plurality of metal pillars protrudes downwardly from a bottom surface of the core substrate,

the top package substrate has, on a bottom surface thereof, a plurality of bottom metal pillars each coupled to a corresponding metal pillar among the plurality of metal pillars of the spacer connector,

the bottom package substrate has, on a top surface thereof, a plurality of top metal pillars each coupled to a corresponding metal pillar among the plurality of metal pillars of the spacer connector, and

the top package substrate is electrically coupled to the bottom package substrate through the plurality of bottom metal pillars of the top package substrate, the plurality of metal pillars of the spacer connector, and the plurality of top metal pillars of the bottom package substrate; and

a bottom chip arranged in the space between the bottom package substrate and the top package substrate, wherein

4

the bottom chip is mounted to the top surface of the bottom package substrate, and the at least one spacer connector comprises two spacer connectors arranged on opposite sides of the bottom chip.

2. The structure of claim 1, wherein a top surface of the bottom chip is spaced downwardly from the bottom surface of the top package substrate.

3. The structure of claim 2, further comprising: a top chip mounted to the top surface of the top package substrate,

wherein in a direction in which the top package substrate is stacked on top of the bottom package substrate, the top chip overlaps the bottom chip and each of the two spacer connectors.

4. The structure of claim 1, wherein each bottom metal pillar among the plurality of bottom metal pillars of the top package substrate is aligned with a corresponding metal pillar among the plurality of metal pillars of the spacer connector, and with a corresponding top metal pillar among the plurality of top metal pillars of the bottom package substrate.

5. The structure of claim 4, wherein the spacer connector is free of metal pads on the bottom ends of the plurality of metal pillars protruding downwardly from the bottom surface of the core substrate, and

each metal pillar among the plurality of metal pillars and the corresponding top metal pad of the spacer connector form a T shape.

6. The structure of claim 4, wherein the bottom ends of the plurality of metal pillars protruding downwardly from the bottom surface of the core substrate of the spacer connector are connected, in an end-to-end manner, to corresponding top ends of the plurality of top metal pillars of the bottom package substrate, and

bottom ends of the plurality of bottom metal pillars of the top package substrate are connected to the corresponding top ends of the plurality of metal pillars of the spacer connector via the corresponding top metal pads of the spacer connector.

7. The structure of claim 4, wherein the spacer connector further comprises a dielectric layer on the bottom surface of the core substrate, and the plurality of metal pillars pass through the core substrate and the dielectric layer.

8. The structure of claim 7, wherein the dielectric layer is a dielectric adhesive in which the core substrate is pasted.

9. The structure of claim 4, wherein the spacer connector further comprises a plurality of bottom metal pads, each on the bottom end of a corresponding metal pillar among the plurality of metal pillars,

the bottom ends of the plurality of metal pillars are connected to corresponding top ends of the plurality of top metal pillars of the bottom package substrate via the corresponding bottom metal pads of the spacer connector, and

bottom ends of the plurality of bottom metal pillars of the top package substrate are connected to the corresponding top ends of the plurality of metal pillars of the spacer connector via the corresponding top metal pads of the spacer connector.

* * * * *