



(19) **United States**

(12) **Patent Application Publication**

Naidoo et al.

(10) **Pub. No.: US 2002/0147982 A1**

(43) **Pub. Date: Oct. 10, 2002**

(54) **VIDEO SECURITY SYSTEM**

Publication Classification

(75) Inventors: **Surendra N. Naidoo**, Austin, TX (US);
William P. Glasgow, Austin, TX (US);
Gregory E. Feldkamp, South Lake, TX (US)

(51) **Int. Cl.⁷** **H04N 7/18**
(52) **U.S. Cl.** **725/105**

Correspondence Address:
THOMPSON & KNIGHT L.L.P.
PATENT PROSECUTION DEPARTMENT
98 SAN JACINTO BLVD., SUITE 1200
AUSTIN, TX 78701 (US)

(57) **ABSTRACT**

A video security system for the remote verification and monitoring of conditions surrounding an alarm signal. A security gateway at the monitored premises detects alarm conditions and transmits information and video relating to the alarm condition to personnel at a central monitoring station in substantially real time for verification. Various embodiments of the system transmit alarm information to the central monitoring station through hybrid-fiber coaxial, DSL, fiber-optic, high-speed fixed wireless and mobile communications networks. The security system may include secondary alarm notification from the security gateway to the central monitoring station via a second network, such as IP, Ethernet, Internet, frame relay, public switched telephone, wireless, and mobile communications networks.

(73) Assignee: **Security Broadband Corp**

(21) Appl. No.: **09/954,976**

(22) Filed: **Sep. 18, 2001**

Related U.S. Application Data

(63) Continuation-in-part of application No. 09/357,196, filed on Jul. 20, 1999.

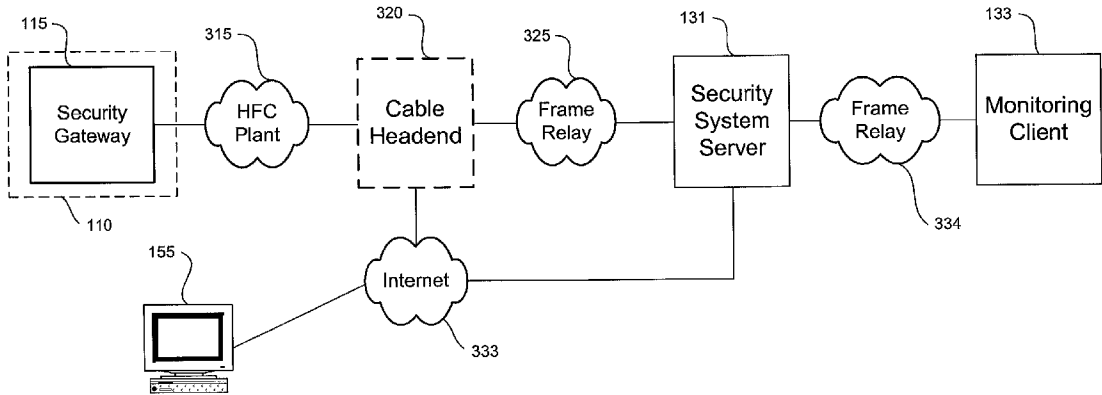

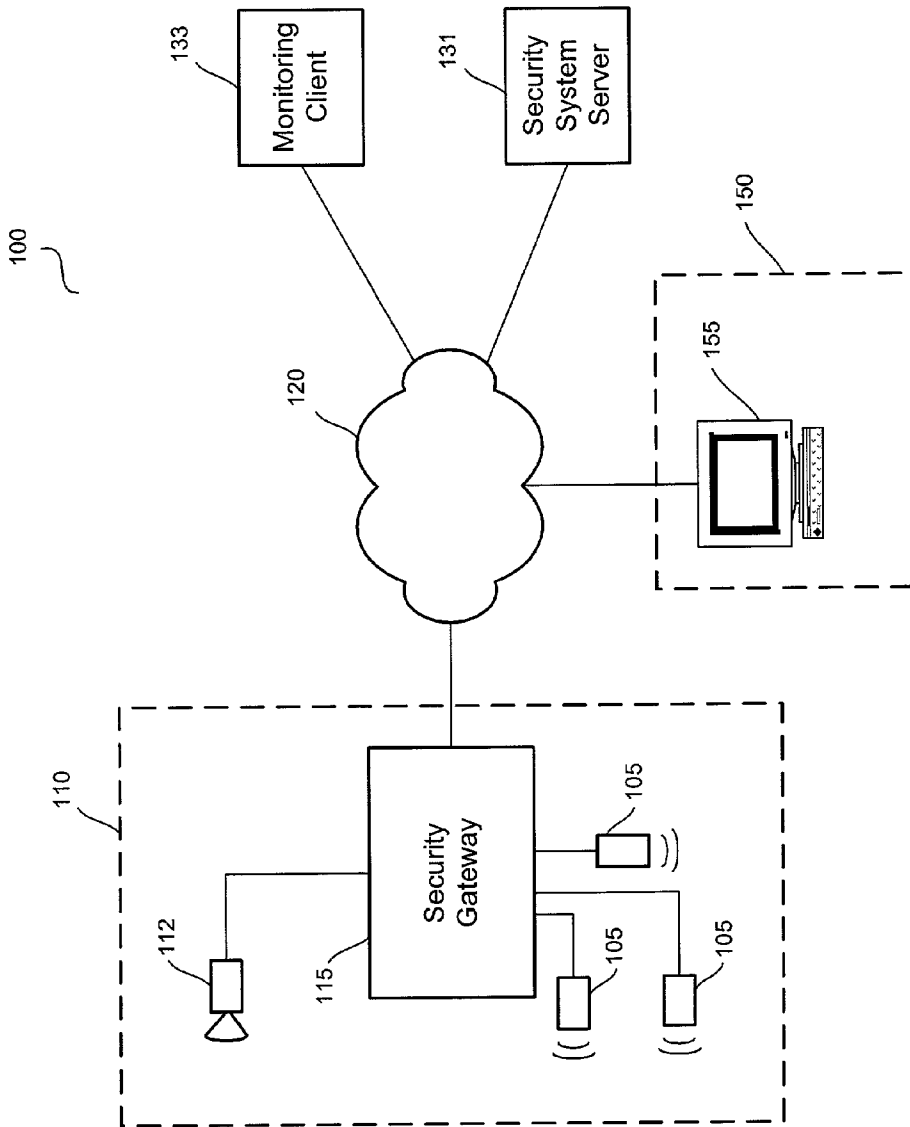

FIG. 1

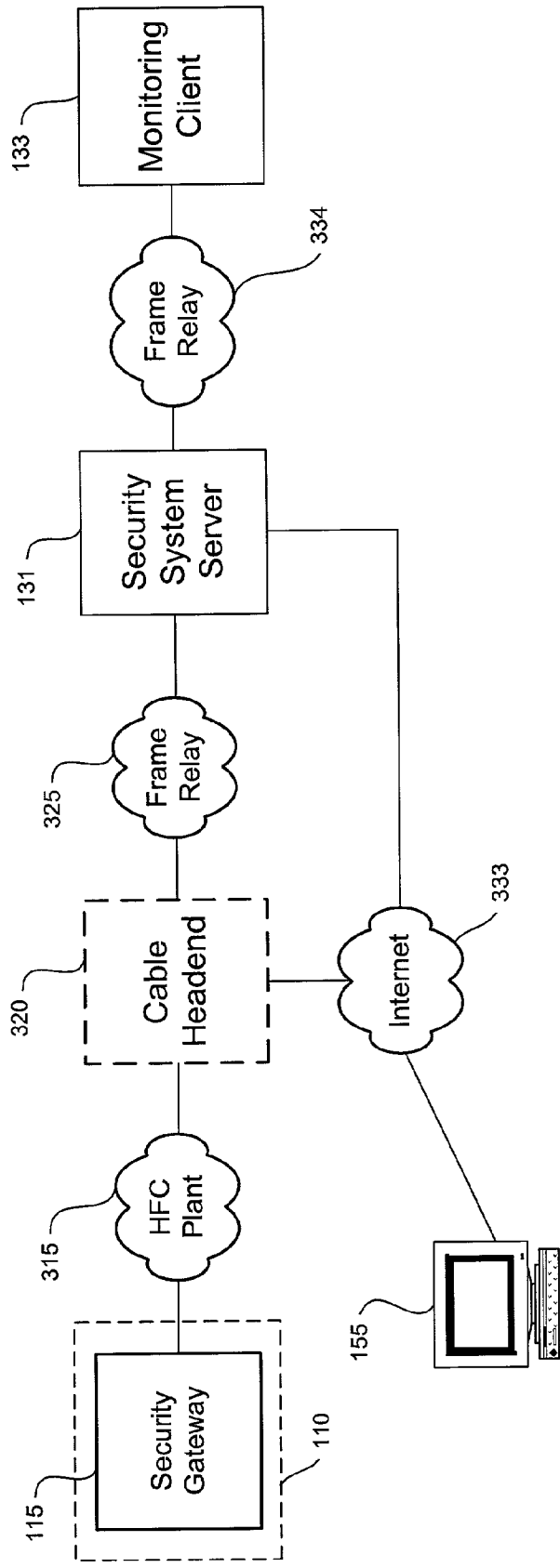

FIG. 3

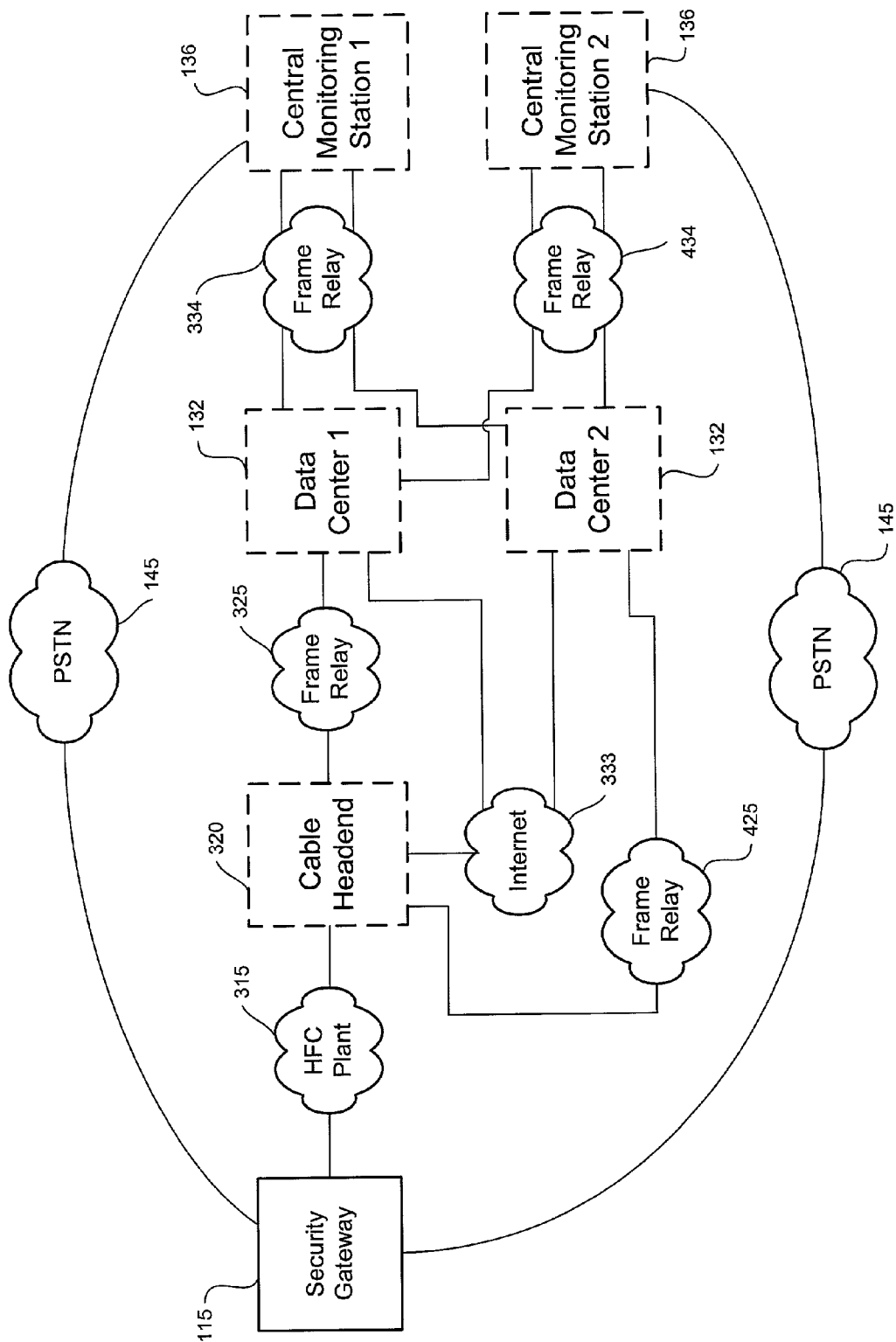

FIG. 4

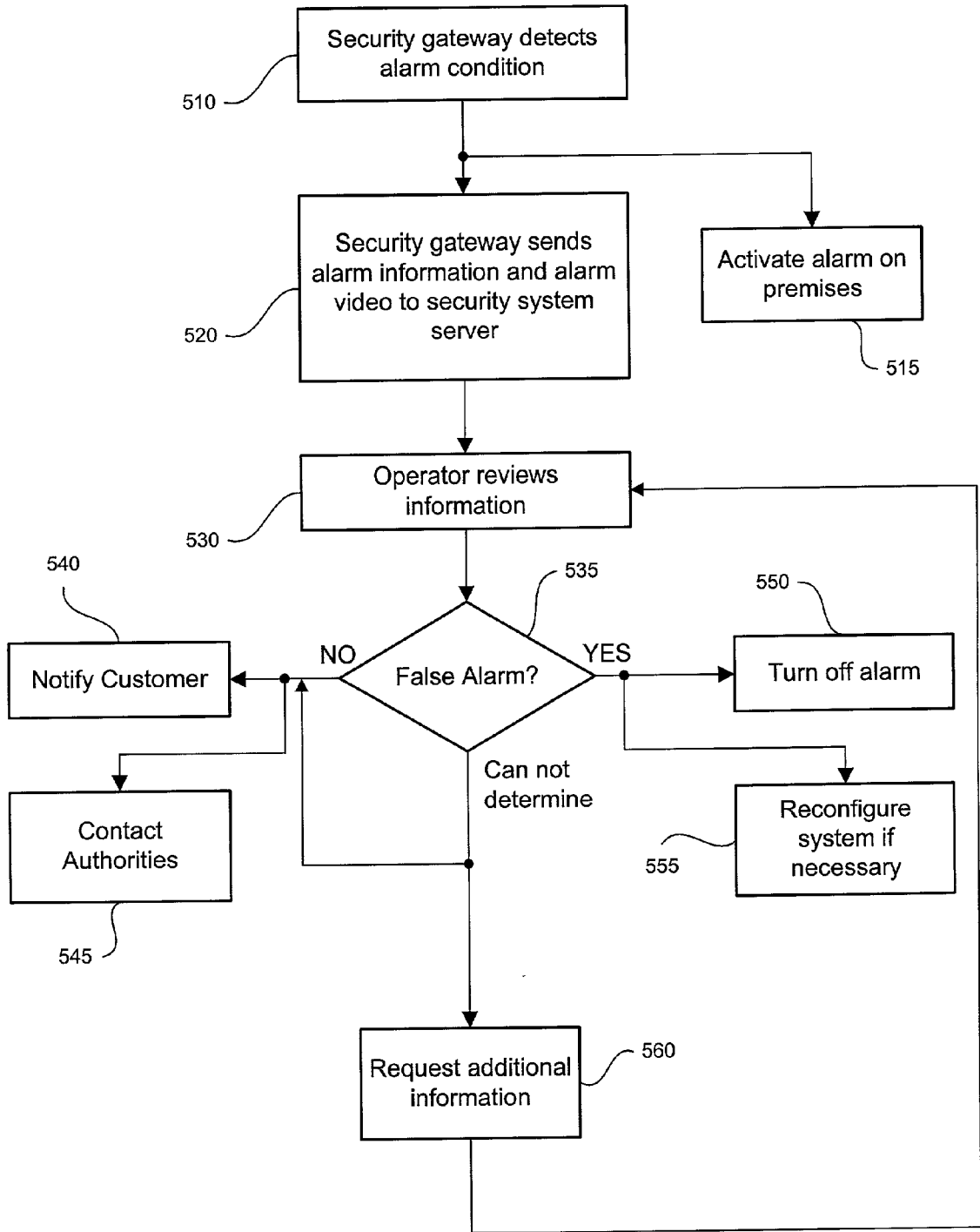

FIG. 5

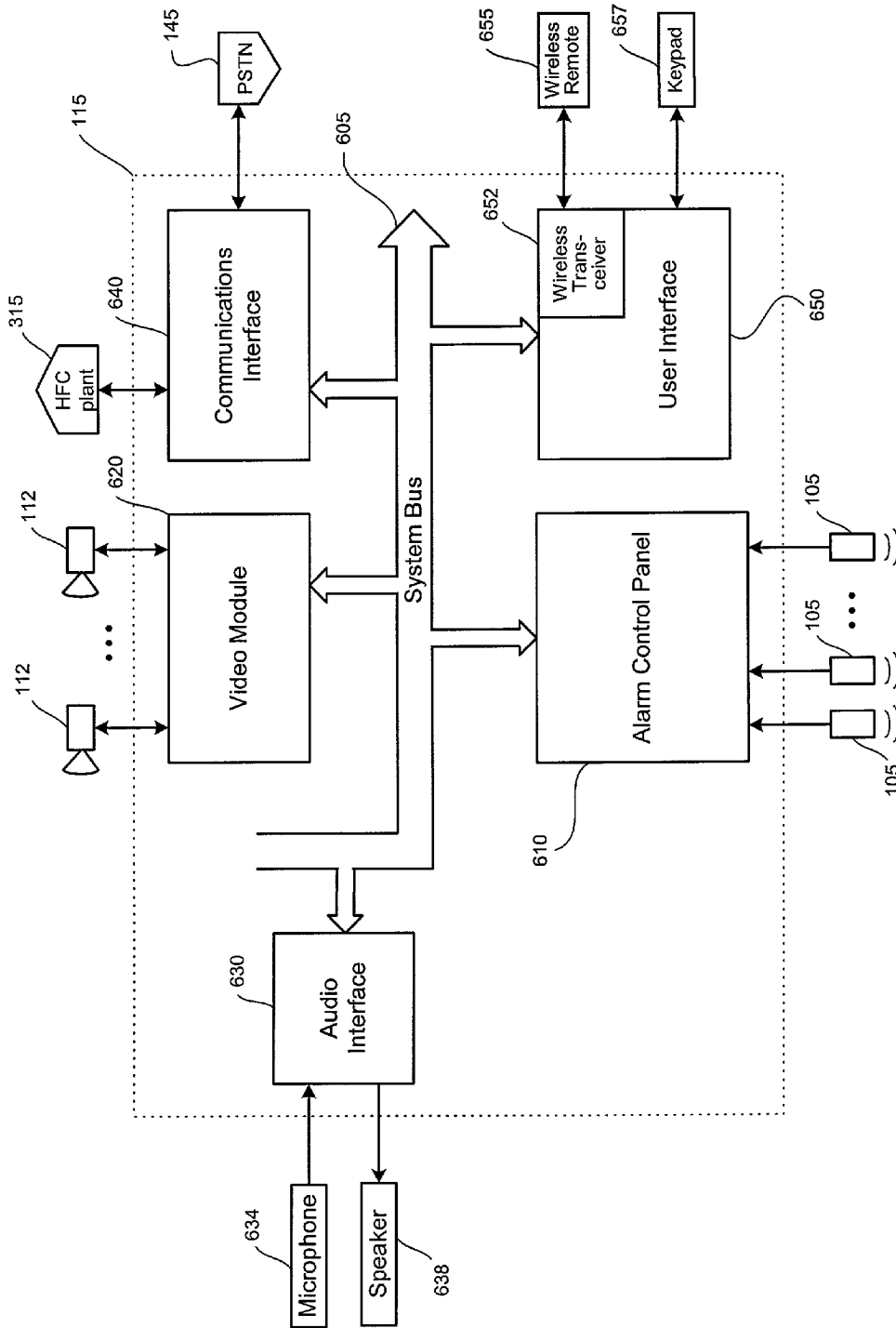

FIG. 6

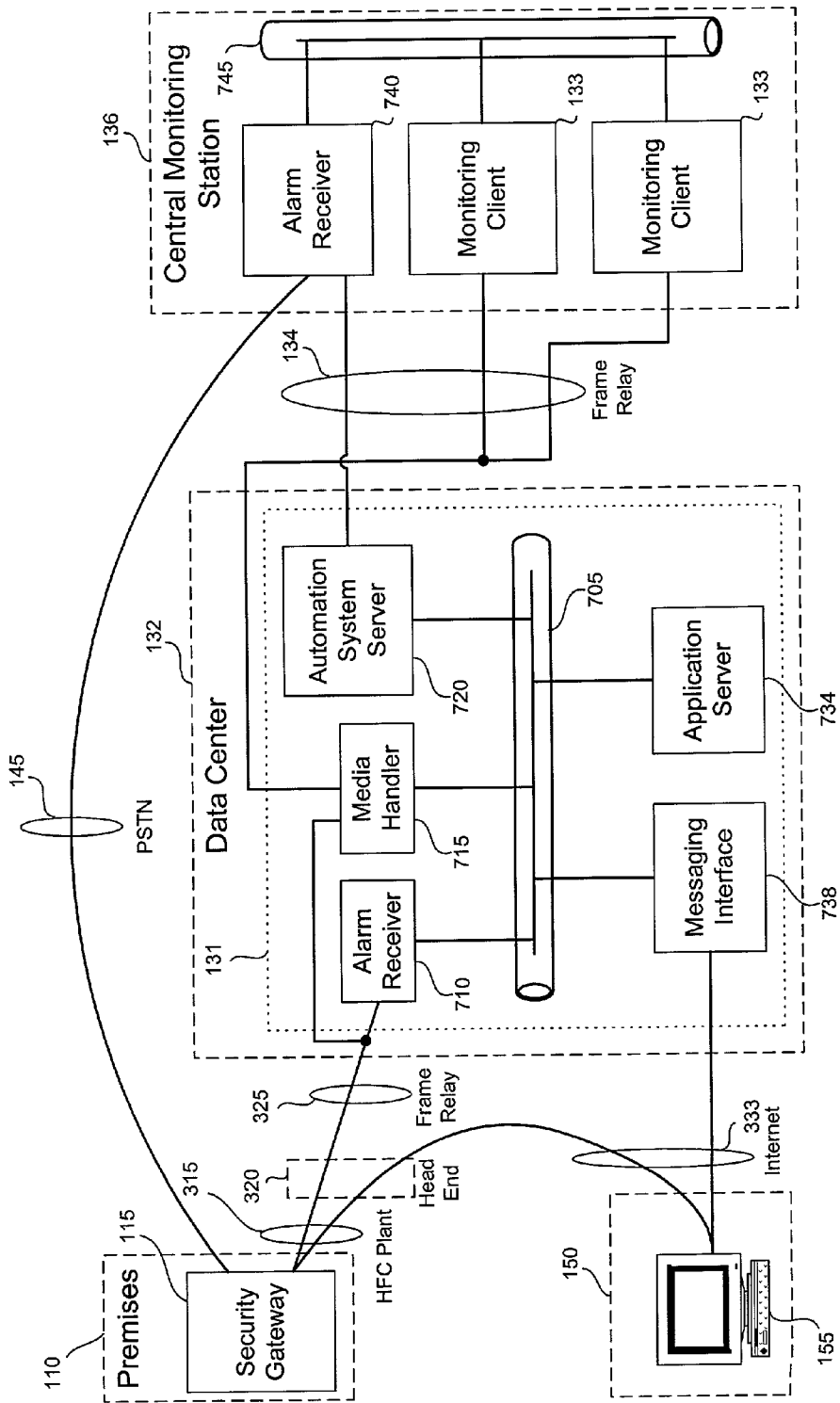

FIG. 7

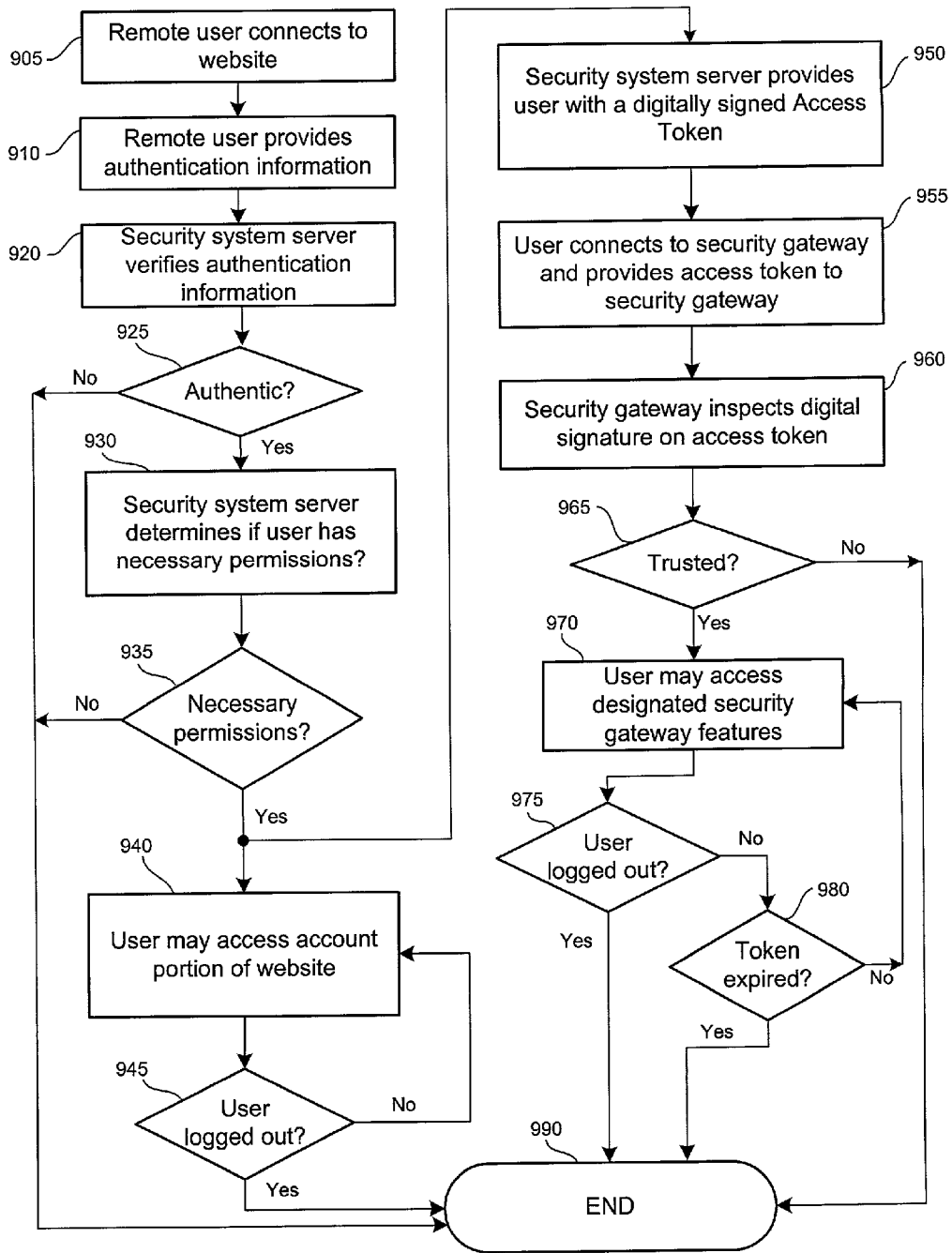

FIG. 8

VIDEO SECURITY SYSTEM

RELATED APPLICATIONS

[0001] The present invention is a continuation-in-part of U.S. application Ser. No. 09/357,196, titled "Security System."

BACKGROUND OF THE INVENTION

[0002] 1. Field of the Invention

[0003] The present invention relates generally to a security system. More specifically, this invention relates to a device and method for the remote verification and monitoring of conditions surrounding an alarm signal.

[0004] 2. Description of Related Art

[0005] Inherent in security systems is the problem of false alarms. In situations where local authorities are notified of alarms, false alarms can result in the owner of the system being subject to significant fines. In addition, false alarms waste the limited resources available to the authorities to respond to legitimate alarm situations. It is therefore desirable that a security system permits verification of detected alarm conditions.

[0006] Conventional security systems typically protect a building using make/break contacts strategically placed at doors, windows, and other potential entry points. Sensors are installed on doors and/or windows. Motion sensors are installed in strategic areas inside the home. Other devices such as glass breakage detectors, panic or medical alert buttons, low temperature and flood sensors can be installed as well. When the system is on and a sensor is tripped, a signal is sent through a wire, or using radio frequencies (on wireless systems), to the main controller which sounds a siren and dials out via telephone or cellular service to the monitoring station whenever an alarm occurs.

[0007] When a contact is broken and an alarm is sounded or relayed to a central control station located within the building, nearby to the building, or remotely to a central control station of the security company. Besides make/break sensors, security companies also use P.I.R. (passive infra red) sensors which sense heat differences caused by animate objects such as humans or animals. Also used are vibration sensors which, when placed upon a window for example, detect when the window is broken, and radio frequency (rf), radar, and microwave sensors, as well as laser sensing. As with the make/break sensors, when any one of the sensors indicates a detection, a system alarm is indicated. A trouble indication is also given if an alarm unit for the building to which the sensors are connected senses that a path to a sensor is interrupted or broken.

[0008] With many current alarm systems, all that the receiver of an alarm, whether at a local or remote central station, knows is that an alarm has occurred. However, the occurrence of an alarm provides no indication as to its cause. Thus, the operator has no other knowledge by which he can determine if an alarm signals the presence of a real intruder, or if it is a false alarm. Sensors may commonly go off during inclement weather (they are sensitive to large electromagnetic fields such as occurring during lightning conditions). Such an erroneous condition is properly referred to as a false

alarm. Regardless of why they occur, all false and unwanted alarms detrimentally affect the efficiency and operation of a security system.

[0009] Many criteria determine whether or not an alarm condition exists. For example, when a person opens a door monitored by a sensor, a potential alarm condition is created. However, an alarm system typically has a keypad or other coded system control by which, if an appropriate entry is made within a prescribed period of time, signifies that the alarm condition is not to be acted upon. Rather, the entrant is someone authorized to enter the premises. Further, the class of intruder (e.g., human or animal) may be perfectly acceptable in one set of circumstances, but not so in another. The common situation is one where an intruder is a human, and his presence results in an alarm being given.

[0010] One technological approach to obtaining such verification is through the use of separate audio monitors operating in concert with separate alarm sensors. U.S. Pat. Nos. 4,591,834 and 4,918,717 are directed to such systems. For example, U.S. Pat. No. 4,591,834 refers to the use of miniature, low-frequency dynamic microphones. Alarm activities noted at the microphones are verified via a separate network of discriminator sensors which comprise geophones. Signal processing techniques are utilized to distinguish alarm activity. Intrusion and discriminator sensors are arranged in known patterns comprised of multiple sensors of each type. U.S. Pat. No. 4,918,717 refers to a system wherein a number of microphones are distributed about a secured premises in relation to other intrusion sensors. Upon detection of an intrusion alarm, the microphones can be manually enabled one at a time from the central station to allow an operator to listen to audio activity in proximity to the sensor alarm.

[0011] Another approach is the use of video images to monitor a location. However, in prior art devices these images have been low-resolution, freeze-frame pictures, making it difficult for a viewer to discern what is being shown. In addition, in many prior art devices, the video images may not be received by the monitoring party until several moments have passed after the recorded event has actually taken place likely causing any response to be late and less effective.

[0012] An additional problem with some existing security systems is that once a person has left the property, it is common for that person to worry that he or she has forgotten to activate or arm the security system. In addition, such persons may have the desire to monitor the property even in the absence of alarm conditions. Further, a person may have the desire to modify aspects of the security system while they are absent. In prior art systems, it has been necessary to telephone a neighbor to ask them to check on the property and report back to the person.

SUMMARY OF THE INVENTION

[0013] The present invention overcomes the above-described problems with prior art security systems.

[0014] In one broad respect, the present invention is directed to a security system comprising a security gateway located at a premises, wherein the security gateway is operable to detect an alarm condition and to record video of at least a portion of the premises relating to the alarm

condition, said video hereinafter referred to as Alarm Video, a security system server operatively coupled to the security gateway through a first network, wherein the security gateway is configured to notify the security system server of the alarm condition and to transfer the Alarm Video to a security system server in substantially real time through the first network, and wherein the security system server is further operatively coupled to the security gateway through a second network, wherein the security gateway is configured to notify the security system server of the alarm condition through the second network. In a narrow respect, the security gateway is further configured to notify the security system server of the alarm condition through the first network substantially simultaneously with notifying the security system server of the alarm condition through the second network. In another narrow respect, the first network is an IP network. In another narrow respect, the first network is an Ethernet-based network. In another narrow respect, the first network comprises the Internet. In another narrow respect, the first network comprises a frame relay network. In another narrow respect, the first network comprises a hybrid-fiber coaxial network. In another narrow respect, the first network comprises a fiber-optic network. In another narrow respect, the first network comprises a DSL network. In another narrow respect, the first network comprises an ATM network. In another narrow respect, the first network comprises a high-speed fixed wireless network. In another narrow respect, the first network comprises a high-speed mobile communications network. In another narrow respect, the second network comprises a public switched telephone network. In another narrow respect, the second network comprises a fixed wireless network. In another narrow respect, the second network comprises a mobile communications network. In another narrow respect, the security gateway is further operable to record audio from at least a portion of the premises relating to the alarm condition, said audio referred to hereinafter as Alarm Audio, and wherein the security gateway is further configured to transmit said Alarm Audio to the security system server through the second network in substantially real time. In another narrow respect, the security system server is configured to provide notification of the alarm condition to a public safety agency. In a narrower respect the security system server is further configured to provide the Alarm Video to the public safety agency. In another narrow respect, the security gateway is further operable to record audio from at least a portion of the premises relating to the alarm condition, said audio referred to hereinafter as Alarm Audio, and wherein the security gateway is further configured to transmit said Alarm Audio to the security system server through the first network in substantially real time.

[0015] In another broad respect, the present invention is directed to a security system comprising a security gateway located at a premises, wherein the security gateway is operable to detect an alarm condition and to record video of at least a portion of the premises relating to the alarm condition, said video hereinafter referred to the Alarm Video, wherein the security gateway further comprises a network interface, and wherein the network interface is configured to connect the security gateway to a cable headend through a first network, wherein said first network is a hybrid-fiber-coaxial network; and a security system server configured to connect to the cable headend through a second network, wherein the security gateway is configured

to notify the security system server of the alarm condition and to transfer the Alarm Video to a security system server in substantially real time. In a narrow respect, the second network is a dedicated bandwidth network. In another narrow respect, the second network comprises a frame relay network. In another narrow respect, the second network comprises an ATM network. In another narrow respect, the second network comprises a managed IP connection having quality of service. In another narrow respect, the security gateway is operatively coupled to the security system server through a third network, the security gateway being further configured to notify the security system server of the alarm condition through the third network. In a narrow respect, the third network comprises a public switched telephone network. In another narrower respect, the third network comprises a fixed wireless network. In another narrower respect, the third network comprises a mobile communications network. In another narrow respect, the security gateway is further operable to record audio from at least a portion of the premises relating to the alarm condition, said audio referred to hereinafter as Alarm Audio, and wherein the security gateway is further configured to transmit said Alarm Audio to the security system server through the second network in substantially real time. In another narrow respect, the security system server is configured to provide notification of the alarm condition to a public safety agency. In a narrower respect, the security system server is further configured to provide the Alarm Video to the public safety agency.

[0016] In another broad respect, the present invention is directed to a security system for providing security monitoring services for a customer comprising a security gateway located at a premises designated by the customer, wherein the security gateway is operable to detect an alarm condition and to record video of at least a portion of the premises relating to the alarm condition, said video hereinafter referred to as the Alarm Video, wherein the security gateway further comprises a network interface, and wherein the network interface is configured to connect the security gateway to a DSLAM through a first network, wherein the first network is a DSL network; and a security system server connected to the DSL through a second network, wherein the security gateway is configured to notify the security system server of the alarm condition and to transfer the Alarm Video to a security system server in substantially real time. In a narrow respect, the second network is a dedicated bandwidth network. In another narrow respect, the second network is a frame relay network. In another narrow respect, the second network is an ATM network. In another narrow respect, the second network comprises a managed IP connection having quality of service. In another narrow respect, the security gateway is operatively coupled to the security system server through a third network, the security gateway being further configured to notify the security system server of the alarm condition through the third network.

[0017] In another broad respect, the present invention is directed to a security system for providing security monitoring services comprising a security gateway located at a premises designated by a user, wherein the security gateway is operable to detect an alarm condition and to record video of at least a portion of the premises relating to the alarm condition, said video hereinafter referred to the Alarm Video, a security system server operatively coupled to the security gateway and a data center, the data center comprising a user information database, comprising data about the

user, said data referred to hereinafter as User Data, wherein the security gateway is configured to notify the data center of the alarm condition and to transfer the Alarm Video to the data center in substantially real time, wherein the security system server is operable to associate the Alarm Video with at least a portion of the User Data, said portion of the User Data referred to hereinafter as Associated User Data, and a monitoring client operatively coupled to the monitoring client, wherein the data center is configured to transfer the notification of the alarm condition, the Alarm Video and Associated User Data to the monitoring client, and wherein the monitoring client is configured to display at least a portion of the Alarm Video and the Associated User Data on the monitoring client. In a narrow respect, the monitoring client is at a central monitoring station. In another narrow respect, the security gateway is further operatively coupled to a central monitoring server at the central monitoring station, and wherein the security gateway is configured to transfer a notification of the alarm condition to the central monitoring server. In another narrow respect, the data center is further operable to store the notification of the alarm condition in the user information database. In another narrow respect, the data center is further operable to store the Alarm Video in the user information database.

[0018] In another broad respect, the present invention is directed to a security system for providing security monitoring services for a plurality of users comprising a plurality of security gateways, each located at a premises, wherein each security gateway is operable to detect an alarm condition and to record video of at least a portion of its respective premises relating to the alarm condition, said video hereinafter referred to the Alarm Video; a security system server operatively coupled to the plurality of security gateways, the security system server comprising a user information database, comprising data about each of the plurality of users, said data referred to hereinafter as User Data, wherein each security gateway is configured to notify the security system server of the alarm condition and to transfer the Alarm Video to the security system server in substantially real time, wherein the security system server is operable to associate the Alarm Video with at least a portion of the User Data, said portion referred to hereinafter as Associated User Data; and a monitoring client operatively coupled to the security system server, and wherein the security system server is configured to transfer the notification of the alarm condition, the Alarm Video and Associated User Data to the monitoring client, and wherein said monitoring client is configured to display at least a portion of the Alarm Video and the Associated User Data. In a narrow respect, the security system server is further operable to store the notification of the alarm condition in the user information database. In another narrow respect, the security system server is further operable to store the alarm video in the user information database. In another narrow respect, the monitoring client is at a central monitoring station.

BRIEF DESCRIPTION OF THE DRAWINGS

[0019] The following drawings form part of the present specification and are included to further demonstrate certain aspects of the present invention. The invention may be better understood by reference to one or more of these drawings in combination with the detailed description of specific embodiments presented herein.

[0020] It is to be noted, however, that the appended drawings illustrate only exemplary embodiments of the invention and are therefore not to be considered limiting of its scope, for the invention may admit to other equally effective embodiments. In addition, although the figures may depict embodiments wherein each of the components represent different devices or locations, they can be combined into a single device or location. In addition, a single component may be comprised of a combination of components.

[0021] FIG. 1 is a simplified block diagram of a security system according to one embodiment of the disclosed system and method.

[0022] FIG. 2 is a more detailed block diagram of a security system according to one embodiment of the disclosed system and method.

[0023] FIG. 3 is a simplified block diagram of a security system utilizing the cable infrastructure according to one embodiment of the disclosed system and method.

[0024] FIG. 4 is a block diagram of a security system featuring redundancy according to one embodiment of the disclosed system and method.

[0025] FIG. 5 is a flowchart of the operation of the security system according to one embodiment of the disclosed system and method.

[0026] FIG. 6 is a more detailed block diagram of a security gateway according to one embodiment of the disclosed system and method.

[0027] FIG. 7 is a more detailed block diagram of a security system according to one embodiment of the disclosed system and method.

[0028] FIG. 8 is a flowchart of depicting the operation of a remote terminal accessing a security system according to one embodiment of the disclosed system and method.

DESCRIPTION OF ILLUSTRATIVE EMBODIMENTS

[0029] The present invention addresses several shortcomings of the prior art with a security system and framework that is configured to deliver real-time information, including video and/or about alarm conditions to monitoring personnel for them to verify alarm conditions and take appropriate follow up action. As a further advantage, the framework may be easily adapted for use in other applications that incorporate real-time information and video delivery.

[0030] The term "security system" is used broadly to mean a system for monitoring a premises, e.g., for the purpose of discouraging and responding to burglaries, fires, and other emergency situations. Such a security system is suited for residential homes, but may also find use with schools, nursing homes, hospitals, businesses or any other location in which real-time information may be useful in obtaining adequate response upon the occurrence of alarm conditions. By integrating broadband features, including audio and video capabilities, web access and wireless capabilities, embodiments of the present invention provides audio and video alarm verification, 24-hour monitoring capabilities, and a secure web-site with remote access features and security-focused content. Embodiments of the present invention may be used to reduce false alarms, improve

police effectiveness, and generally increase its users' peace of mind while they are away from home.

[0031] Referring to the drawings, FIG. 1 is a high-level block diagram of an exemplary security system according to one embodiment of the present invention. The security system 100 includes a security gateway 115 (also called a "base station"), which is typically located at the desired premises 110 to be monitored, and a monitoring client 133, typically located at a central station and operatively coupled to security gateway 115 through a network 120. Often, security gateway 115 is located at the target site. However, on some occasions, some or all components of security gateway 115 may be located remotely, but remain operatively coupled to security sensors 105 and video cameras 112 which are at the premises. Upon detection of an alarm condition, security gateway 115 captures video (usually through an attached video camera 112) of the target site, and sends the video to security system server 131 in real time.

[0032] For purposes of the present invention the term "premises" refers to any location to be monitored, whether residential, commercial, public, or secured. Further, the term "a" is generally used in the present disclosure to mean one or more. Still further, the terms "coupled" and "operatively coupled" mean connected in such a way that data may be exchanged. It is understood that "coupled" and "operatively coupled" do not require a direct connection, a wired connection, or even a permanent connection. It is sufficient for purposes of the present invention that the connection(s) be established for the sole purpose of exchanging information.

[0033] In general, network 120 may be a public network or private network, a single network or a combination of several networks. In most embodiments, network 120 may be, but is not required to be, an IP-based network. In some embodiments it may be desirable for all or a portion of network 120 to include publicly available networks, such as the Internet, to avoid the need for installing, purchasing, or leasing additional infrastructure. However, in some systems, e.g. those that use high-bandwidth transmissions, it may be desirable to include dedicated high-bandwidth connections including, without limitation, as leased lines, frame relay networks, and ATM networks, within network 120. Further, in some systems it may be desirable to use a network 120 with quality of service guarantees given the real-time nature of the information that is transmitted.

[0034] In the present disclosure, the term "high-speed" or "high-bandwidth" connections generally means those connections capable of providing enough bandwidth for data to be transmitted to the central station in real-time. In one embodiment, high-speed connections are those capable of transmitting at speeds of at least 128 KBPS. High-speed connections include but are not limited to cable modem connections, xDSL connections, and high-speed wireless connections.

[0035] Generally, security gateway 115 is a processor-based device that functions to detect alarm conditions at a target site, to capture information relating to such alarm conditions, and upon occasion of an alarm condition, to send such information ultimately to security system server 131 for verification and response. Monitoring client 133 is generally a software program that may be used to display some or all of the information provided by security gateway 115. Monitoring client 133 may be a stand-alone program or

integrated into one or more existing software programs. One or more operators may then use this information to evaluate whether the alarm condition corresponds to an actual alarm condition and then take additional action, if desired, such as alerting the appropriate authorities. Advantageously, in many instances the incidence of false alarm being reported to the authorities is reduced, and the response effectiveness of the authorities is improved.

[0036] Security system 100 may include one or more sensors 105 coupled to security gateway 115 to detect alarm conditions. Security system 100 is not limited to any specific type or model of sensor 105. Any sensor 105 may be used, depending on the desired type and level of protection. Examples include, without limitation, magnetic contact switches, audio sensors, infrared sensors, motion detectors, fire alarms, and carbon monoxide sensors. Alarm sensors 105 may be wired directly into an alarm control panel built into security gateway 115 or they may be wirelessly connected. The type of sensor 105 to be used depends on the specific application for which security system 100 is designed. In some embodiments, multiple alarm sensors 105 may be used. In such multiple sensor embodiments, security gateway 115 may consider data from all, some, or one of sensors 105 in the detection of alarm conditions.

[0037] In addition, security system 100 includes one or more video cameras 112 that is operable to capture video of monitored premises 110. Camera 112 may be (but is not required to be) a 360-degree camera or a panoramic camera. In addition, security gateway 115 may be configured to create an association between one or more sensors and an associated video camera 112. Whether separate alarm sensors 105 are present or not, security gateway 115 may use video from video camera 112 to assist in the determination of whether an alarm condition exists and thereby whether to generate and send an alarm signal to the security system server 131. For example, in one embodiment, sensors 105 such as motion detectors, infra-red and audio sensors may be replaced by an intelligent alarm module that is able to detect motion or intrusion by analyzing the video image generated from camera 112. In another embodiment, security gateway 115 may analyze images from camera 112 and audio sound from an audio sensor 105 to detect an alarm condition. In some embodiments, the sensitivity of system 100 may be adjusted to account for the size and speed of intruders. For example, system 100 may be adjusted to trigger an alarm if a person walks across a monitored area but not a dog walking across the same area. Advantageously, a visual intelligent security system based on changes in the video image eliminates the need for many sometimes-expensive hardware sensors. Intelligent alarm applications typically require a significant amount of processing by security gateway 115, but may be easier to setup, maintain and upgrade since they are generally programmable. In one embodiment described below in greater detail, security gateway 115 may include a processor and memory to record and process video information for the intelligent alarm application.

[0038] The alarm video sent to the security system server 131 preferably begins at least just prior to the occurrence of the alarm condition and may end upon after the conclusion of the alarm condition, or alternatively, after a specified duration. Preferably, the segment shows enough of a time period to provide monitoring personnel with enough information to determine whether the alarm signal is a false alarm

or not. In some embodiments, the segment of real-time video may be compressed using any compression techniques known by one of skill in the art. For example, this may involve the use of video compression algorithms such as "mpeg." Further, the resolution and/or color depth of the video may be reduced to reduce the required transmission bandwidth.

[0039] In one embodiment, alarm video is transmitted at least 3 frames per second. In addition, the alarm video may have an end resolution (i.e., after interpolation and/or image enhancement, etc.) of 320 pixels by 240 pixels or higher, and optionally may be transmitted in color. Further, said alarm video may but is not required to include a corresponding audio portion.

[0040] It is noted that the present invention is not limited to any particular audio, video, or communications standards. The present invention may incorporate any such standards, including, without limitation: H.323, ADPCM, H.263, MPEG, UDP, and TCP/IP.

[0041] In some embodiments, security gateway 115 may be installed similar to a conventional security system, e.g., mounted between studs in an unfinished area of the residence, for example a utility room. Preferably, cabling to security gateway 115 is restrained such that the cables cannot be pulled out of the unit, and security gateway 115 panel may be in a cabinet that can be locked to prevent unauthorized physical access.

[0042] In addition, because security gateway 115 is coupled to a network 120, it may be desirable to implement precautions to minimize risk from hackers, e.g., by minimizing the number of access points for hackers who might try to gain access to the unit. In addition, communication with security gateway 115 may be restricted and security gateway 115 may strictly control access, similar to a firewall with most ports blocked and having no external way to open them.

[0043] In addition, some embodiments of the present invention may include the functionality to allow access to security gateway 115 and security system server 131 using a remote station 155 operatively coupled to security gateway 115 and security system server 131. Remote user 155 must first be authenticated by security system server 131. It is noted that the present invention contemplates the use of any authentication techniques. Once authenticated, remote user may access some or all of the features of base station 115. These features may include, without limitation, arming or disarming the security system; adjusting sensitivities of sensors (if present); adjusting alarm condition detection sensitivity; remote surveillance; adjusting camera settings; and reviewing alarms and recordings. These functions may also include remote surveillance, referred to as "lifestyle video."

[0044] Remote user 155 may connect to security system server 131 and base station 115 (after authentication) through network 120. Because a remote user does not necessarily need real-time access to alarm video, a low-bandwidth connection may be used to connect remote station 155 to security system server 131 and base station 115. After authentication, security system server 131 may be configured to create a data connection between remote station 155 and security gateway 115 such that communi-

cations between remote station 155 and security gateway 115 bypass security system server 131. Advantageously, this avoids network bottlenecks at the security system server 131, particularly when transmitting large amounts of data such as during the transmission of streaming video.

[0045] In one embodiment, remote user 155, once authenticated, may perform remote surveillance through base station 115. The remote surveillance feature allows remote user 155 to view all or portions of the video signal from video camera 112. Depending on the bandwidth of the connection, the video may be of a lower quality than that transmitted to security system server 131 for verification of alarm signals. For example, in one embodiment, the video transmitted to remote user 155 may have a lower frame rate, lower resolution, and/or lower color depth. In addition, remote user 155 may be able to configure the quality of the video for remote monitoring. To address privacy concerns, an audio or visual indicator may be included to allow occupants at the premises to know that they are under remote surveillance.

[0046] In some embodiments, security gateway 115 may include a secondary alarm notification for transmitting alarm notifications to the security system server 131 through a secondary network. Such a system provides additional security in the event the primary system is damaged due to, for example, an accident, sabotage, or system failure. For example, the secondary network may include the public switched telephone network for transmitting alarm notification to security system server 131. Other examples of the secondary network include, without limitation, a fixed wireless network or mobile communications network.

[0047] In these embodiments, alarm notification may be sent at approximately the same time (or substantially simultaneously) through both network 120 and the secondary alarm notification network. Advantageously, this ensures that the security system server 131 is alerted of the alarm condition as early as possible.

[0048] In addition, security system server 131 may be operable to detect whether security gateway 115 is properly coupled to it. For example, in one embodiment, security system server 131 may "ping" security gateway 115 on a regular basis through network; if security system server 131 does not receive a response from security gateway 115, monitoring personnel at security system server 131 can take appropriate action. In this embodiment, it is preferable that security system server 131 may ping security gateway 115 with enough frequency such that appropriate action may be taken in a timely manner if security gateway 115 becomes uncoupled from security system server 131. More particularly, security system server 131 may be configured to ping security gateway 115 at least once every minute. Alternatively, the security gateway 115 may be configured to send a periodic heartbeat notification to the security system server 131. In these embodiments, the security system server 131 would expect to receive a heartbeat notification message once during each predefined interval. If a heartbeat message is not received, the security system server 131 would know that there may be a problem, and monitoring personnel may take the appropriate follow up action, such as contact the person responsible for the premises.

[0049] Additionally, security gateway 115 may be configured to detect if its network connectivity is lost, and send notification to the security system server 131 via the sec-

ondary backup. If network connectivity is lost while the system is disarmed, but the system is armed before network connectivity is restored, notification is again via the secondary alarm notification network.

[0050] FIG. 2 depicts an embodiment of the present invention where the security system server 131 and monitoring client 133 are located at two separate locations—namely, a data center 132 and a central monitoring station (“CMS”) 136. As shown, security gateway 115 is operatively coupled to data center 132 through network 120, which is, in turn, operatively coupled to central monitoring station 136 through network 134. Any alarm notification and video information sent by security gateway 115 is transmitted to the security system server 131 at the data center 132. The security system server 131 logs the alarm notification and retrieves information about the customer, which may include, without limitation, any prior alarm notifications or events. The security system server 131 also transmits the alarm notification and video information, along with any additional information, to the central monitoring station 136, where it may be displayed on monitoring client 133. One or more operators at the CMS 136 may then use this information to determine if an alarm condition exists.

[0051] CMS 136 generally is a centralized monitoring facility containing one or more monitoring clients 133 and staffed by monitoring personnel. In particular, CMS 136 may be staffed by one or more monitoring agents or operators that are trained to review alarm video on monitoring client 133 and determine whether an alarm condition exists. Because of the sensitive nature of the job, it may be desirable that access to operations rooms at the CMS 136 be restricted, and employees working at CMS 136 be subjected to drug testing and reference and background checks. In addition, in some states, security system employees must be registered for security monitoring, which may require submission of fingerprints as well as a criminal background check against both Department of Public Safety and FBI records. With respect to training, it may be desirable for CMS 136 personnel to attend Securities Industry Association (SIA) training, which includes basic alarm system training as well as training on the security system server 131 and the telephone system.

[0052] Monitoring client 133 notifies monitoring personnel of alarm conditions and manages responses to these events. In addition, monitoring operators may use monitoring client 133 to retrieve customer information, pass codes, and provide summaries of previous events. Monitoring operators may access audio and video data associated with the current alarm condition. Monitoring client 133 may also allow monitoring personnel to review audio and video content associated with closed (i.e. historical) alarm conditions. Though the central monitoring station may be described conceptually as “centralized,” it may actually consist of several physically distributed locations.

[0053] In addition, with the configuration depicted in FIG. 2, technology-intensive equipment including the security system server 131 may be kept in the data center 132 is where physical access to data center 132 may be strictly controlled. Advantageously, in this configuration, non-technical personnel may be kept away from the sophisticated and expensive equipment in the data center 132, and the non-security-related personnel would not have access to sensitive alarm videos.

[0054] In the illustrative embodiment, communications between security gateway 115, data center 132, and CMS 136 occurs through a combination of public and private networks. In particular, security gateway 115 is coupled to data center 132, which is coupled to CMS 136 through network 134. In one embodiment, network 120 is a publicly available network and network 134 is a dedicated network, such as a leased line, frame relay network, or ATM network. Advantageously, maintaining dedicated lines between headend 320 and data center 132 and between data center 132 and monitoring client 133 provides a secure connection from headend 320 to monitoring client 133. In another embodiment, not shown, data center 132 may be coupled to CMS 136 through network 120.

[0055] In addition, in some embodiments, part or all of central monitoring station 136 may be implemented in a redundant manner at different network locations, as discussed below with respect to FIG. 4.

[0056] Uninterruptible power supplies and/or backup generators may be used at the data center 132 and central monitoring station 136 to protect against power surges and blackouts. In addition, in some embodiments, the perimeter of the operations rooms at the data center 132 and central monitoring station 136 is fire resistant. Also, in some embodiments, data center 132 and CMS 136 may be implemented in several locations. The “data center” would then refer to the aggregate of all of them and the block diagram would show the conceptual relationship. Also, data center 132 and CMS 136 may have redundant systems to guard against failure. In addition, in some embodiments, data center 132 and CMS 136 may be coupled through separate redundant connections. Advantageously, the use of some or all of the preceding precautions helps to ensure that the system perform reliably even in the face of disaster conditions.

[0057] In other embodiments, not shown, the security system may include a plurality of distributed monitoring clients 133, which may be located at one or more locations, coupled to security system server 131. One or more of such monitoring clients 133 may be located at a central monitoring station, but some monitoring clients 133 may be located at other locations. In one embodiment, at least some of the monitoring clients 133 are coupled to the security system server 131 through the Internet. With all such embodiments, security system server 131 may route an alarm notification and alarm video to one or more monitoring clients 133 based using rules-based routing. For example, an alarm notification and related video may be delivered to one or more monitoring clients 133 that have the current availability to review them. Other criteria that may be considered by a rules-based routing engine include, but are not limited to, geographical location of the monitoring client 133, skills of the monitoring client 133, and network efficiencies.

[0058] As shown in FIG. 3, some embodiments of the present invention contemplate the use of the cable television infrastructure (which may include, without limitation, HFC plant 315 and cable headend 320) and cable modem technology for the broadband transmission and receipt of information. As shown, security gateway 115 may be coupled through headend 320 to a security system server 131, which is further coupled to monitoring client 133. In a typical configuration, numerous security gateways 115 would be

connected to a single headend **320**. Similarly, several headends **320** may be coupled to each security system server **131**.

[**0059**] Advantageously, the broadband connection provided by a cable modem connection provides the high throughput that is required for transferring large amounts of data, as is required when transmitting video. Accordingly, high-quality video may be transmitted from the security gateway **115** in substantially real-time to security system server **131**, where it may be distributed to monitoring client **133**. This allows personnel using monitoring **133** to review the video while there is still time to take action. A further advantage is that the cable infrastructure is already in place for many homes and businesses, reducing installation costs.

[**0060**] There are two main cable modem standards, the Multimedia Cable Network System (MCNS)'s Data Over Cable Service Interface Specification (DOCSIS), and the 802.14 from the Institute of Electronics and Electrical Engineering (IEEE), which are hereby incorporated by reference. The present invention contemplates the use of these and other cable modem standards.

[**0061**] In a typical large market cable network, a regional cable headend **320** (typically serving up to 200,000 to 400,000 homes) feeds distribution hubs (each serving up to 20,000 to 40,000 homes) through a metropolitan fiber ring. At the distribution hub, signals are modulated onto analog carriers and then transported over fiber-optic lines to nodes (not shown) serving up to 500 to 1,000 locations. From the node, these signals are carried via coaxial cable to a home or business.

[**0062**] Headend **320** receives television signals via satellite and local broadcast and converts them to signals that can be sent over coaxial cable to subscribers. To deliver digital data, headend **320** controller modulates the IP packets, encodes them as a digital signal, and broadcasts the signal down the cable on an unused channel. The cable modem demodulates the incoming signal and translates it back into IP packets the computer can understand. The cable modem also sends data upstream to the Internet through the cable system. At the user location, the television signal is received by a set-top box, while user data is separately received by a cable modem box.

[**0063**] Older cable networks used a large amount of coaxial cable (in a tree-and-branch topology) with the associated need for many amplifiers. Many modem networks, such as the one depicted, operate over a hybrid fiber/coax (HFC) plant **315**, with increasingly high fiber content, coming within a few hundred meters of subscribers' locations. In particular, they may have fiber-optic backbones that terminate in fiber coaxial neighborhood node. The combination of deeper fiber penetration in the cable access network combined with modem digital modulation techniques has increased the bandwidth that can be delivered to cable customers. It is noted that other cable infrastructures may be used without departing from the scope of the invention.

[**0064**] Still referring to **FIG. 3**, headend **320** includes a connection to security system server **131** through network **325**. In some embodiments, the connection between headend **320** and security system server **131** is a dedicated and/or guaranteed connection, such as through a frame relay network (as shown). An advantage to having such a connection

is a level of service and/or bandwidth that may be difficult to obtain over public networks such as the Internet. Specifically, with existing TCP/IP network such as the Internet, a degree of latency and unpredictability are often unavoidable. However, in some embodiments, such latency and unpredictability may be acceptable.

[**0065**] In other embodiments, other broadband infrastructures such as DSL, fiber, and wireless may be used without departing from the scope of the invention. In such other embodiments, it may be desirable to have a dedicated or private connection to the security system server **131** from an aggregation point in the infrastructure (such as the cable headend in cable modem networks, and the DSLAM in DSL networks).

[**0066**] Embodiments of the present invention may incorporate redundancy for some or all of the components of the security system **100** to ensure that alarm conditions are responded to as quickly as possible, even in the event of partial system failure. **FIG. 4** illustrates one such embodiment. As shown, both the data centers **132** and central monitoring stations **136** are implemented redundantly. It is understood by one of skill in the art that the present invention is not limited to the architecture depicted in **FIG. 4**. Any other existing or future redundancy or load-balancing technology may be used without departing from the scope of the present invention.

[**0067**] Referring now to **FIG. 5**, a flowchart diagram is shown illustrating the operation of a security system as described above, according to one embodiment of the present invention.

[**0068**] In step **510** security gateway **115** detects an alarm condition corresponding to a possible alarm event. This may result from a triggered sensor, analysis of recorded video, the pressing of a panic button, or any combination thereof. Optionally, upon detection of an alarm condition, security gateway **115** may activate **515** a siren, ring a bell, and/or otherwise sound an audio alarm on the premises. Advantageously, this may scare away any intruder(s) while an operator at the central monitoring station verifies the alarm signal. As a further option, after security gateway **115** detects an alarm, either the security gateway **115** or security system server **131** may also transmit the alarm signal and alarm video corresponding to the alarm condition automatically to customer (whose home, business, or other location is being monitored) at an email address by any other electronic means.

[**0069**] In step **520**, upon detection of an alarm event **510**, alarm information may be sent from security gateway **115** to the security system server **131** and may include a notification of the alarm event and information relating to the alarm event, which may include alarm video. In the present disclosure, the term "alarm video" shall mean generally a segment of video corresponding in time to an alarm condition and may include audio. The alarm information may, but is not required to, contain information regarding the detected alarm event including, but not limited to, the type of sensor that detected it, and data from that sensor regarding the detected alarm condition. In addition, security gateway **115** may, at the same time, notify alarm receiver **740** at the central monitoring station **136** of the alarm event through the secondary alarm channel (PSTN **145**). Since this secondary notification channel is typically a low-bandwidth connec-

tion, alarm video is generally not sent. However, in some embodiments, audio and other additional lower-bandwidth-intensive data is sent through PSTN 145. In these embodiments, alarm receiver 740 alerts security system server 131 and one or more monitoring clients 133 of the alarm condition at premises 110.

[0070] The primary means of this notification is through network 120. However, as discussed above, a secondary alarm notification may be used. When the secondary PSTN alarm notification is used, the security gateway may be configured to seize the telephone line to report the alarm to a monitoring client 133. Typically, the secondary alarm network is of low-bandwidth. Accordingly, only the alarm notification is sent. However, in some embodiments, a higher bandwidth network may be used for the secondary alarm notification. In such cases, the alarm video may also be sent.

[0071] After receiving alarm notification 520, security system server 131 relays the notification to one or more monitoring clients 133. The security system server 131 may also be configured to automatically retrieve stored data regarding the premises 110, the customer, or both and provide it to the monitoring clients 133. Such information may include, without limitation, an alarm history, whether the customer is on vacation, and any other information that the system may be configured to store.

[0072] In step 530, monitoring client 133 notifies a monitoring operator of alarm conditions and managing responses to these events. Preferably, the alarm video is received and displayed by monitoring client 133 closely in time to the detection of the alarm condition such that if follow up action is necessary, it can take place in a timely manner. For example, if security gateway 115 detects an alarm condition corresponding to a possible fire, it is imperative monitoring personnel notify fire department as quickly as possible.

[0073] CMS operators can retrieve customer contact information, pass codes, and summaries of previous events. In addition, CMS operators can also access audio and video associated with the current alarm condition. Operators can access live audio and video from the home, and the operator can switch between available cameras and control the muting of individual microphones. In addition, in certain circumstances video from non-alarm conditions may also be viewed—for example, with an exterior camera 112, positioned at the front door of a residence. In some embodiments, due to privacy concerns, monitoring client 133 may be configured to only allow display audio and video content associated with an open alarm conditions. Once the alarm condition has been closed by an operator, that content may no longer be made available for viewing. Optionally, monitoring client 133 may be configured to provided to CMS monitoring personnel for viewing video and audio content associated with closed (i.e. historical) alarm conditions. However, in other embodiments, it may be desirable that CMS personnel be able to view certain non-alarm video to aid in verifying an alarm condition. For example, in one embodiment, during the time an alarm condition remains open, CMS personnel may view non-alarm video that is related to the alarm condition. In addition, controls can be implemented to address privacy concerns. An example includes, but is not limited to, only providing non-alarm video recorded during the time the security system is armed.

It is noted that in some embodiments of the present invention, video is only recorded when the system is armed. However, the present invention is not limited as such.

[0074] In step 535, a monitoring person or monitoring personnel staffing the monitoring client 133 verifies whether the alarm signal corresponds to an actual alarm condition using the alarm signal information and the segment of real-time video. In some instances, the alarm video is indeterminate as to whether the alarm signal corresponds to a false alarm. Advantageously, various embodiments of the present invention address this problem. For example, monitoring client 131 may be configured to allow monitoring personnel to request additional video or information 560 from security gateway 115 and/or security system server 131. In addition, the monitoring client 133 may be configured to initiate two-way audio communication with the monitored location to allow the monitoring personnel to attempt to obtain more information. Alternatively, monitoring personnel may call the monitored location or the customer at a contact number to try to determine whether the alarm signal is false. In some embodiments, indeterminate alarm signals may be treated as authentic.

[0075] If the alarm signal is deemed to be false, the monitoring client 133 may inform security gateway 115 of this designation such that security gateway 115 can take any appropriate follow up action(s). For example, security gateway 115 may immediately turn off any siren, bell, or other audio alarm 550. Other examples include but are not limited to security gateway 115 resetting itself, logging the event, and/or adjusting its sensitivity settings to try to avoid future false alarms 555. Further, data center 132 may be configured to either manually and/or automatically adjust said sensitivity settings to potentially avoid future false alarms 555.

[0076] If the alarm signal is deemed not to be a false alarm, monitoring personnel may take the appropriate follow-up action. Typically, this includes notifying the customer 540 and contacting the appropriate authorities 545, which may be the police department, emergency medical dispatch, or any other public safety agency. Advantageously, such authorities may be inclined to respond more promptly and/or with a higher sense of urgency because the probability of the alarm being false is reduced.

[0077] In some embodiments, the security system of the present invention may integrate directly with the systems of various emergency response agencies. For example in one embodiment, upon verification of an alarm condition at the central monitoring station, an alarm notification and alarm video may be transmitted directly into a police dispatch system.

[0078] FIG. 6 illustrates an exemplary embodiment of the security gateway. As shown, security gateway 115 may include alarm control panel 610, video module 620, user interface 650, communications interface 640, and audio interface 630. As shown, the components of security gateway 115 are configured to communicate with one another through system bus 605. In other embodiments, some or all of the components may be directly connected or otherwise operatively coupled to one another.

[0079] Alarm control panel 610 performs many of the same functions as traditional alarm control panel. For example, alarm control panel 610 interfaces with one or

more sensors **105**, which may be wired or wireless. In some embodiments, not shown, it may include an interface to the PSTN **145**. However, as shown, the interface to the PSTN may be contained in the communications interface **640** instead of the alarm control panel **610**. The alarm control panel **610** is preferably capable of operation in isolation as per UL requirements for residential fire applications and residential burglary operations. Alarm control panel **610** is further capable of continuing to operate in the traditional manner regardless of the state of the video subsystem. In an exemplary embodiment of the present invention, alarm control panel **610** is a COTS unit.

[0080] Further, alarm control panel **610** may be configured to communicate with the other components of the security system to monitor their operational state. Information that the alarm control panel **610** may receive includes, but is not limited to, whether security gateway **115** can communicate with the security system server through the communications interface **640**, information about AC power failure, trouble by zone, fire trouble, telephone line trouble, low battery, bell output trouble, loss of internal clock, tamper by zone, fail to communicate, module fault, camera trouble, and intercom trouble. The detected operational failure of any component in security gateway **115** may be indicated by a communications loss between components and a concurrent alarm condition reported by alarm control panel **610** and displayed for the user on user interface **650** or announced through audio interface **630**. In addition, any detected operation failures may be communicated to the security system server through communications interface **640**. Alarm control panel **610** may also be configured to record alarm conditions and associated data in memory. The security system server may also be configured to record alarm conditions and associated data in addition to or in lieu of alarm control panel **610** doing so. In other embodiments, other components of security gateway **115** may be configured to perform this function. For example, in one embodiment, video module **620** records alarm conditions and the associated data.

[0081] Video module **620** may perform many functions including but not limited to analyzing data from alarm sensor **105** and/or video camera **112** to determine whether an alarm condition exists; accessing data stored in memory; generating alarm video to transmit to security system server **131** in response to detection of an alarm condition; and communicating with security system server **131** and remote user **155** through communications interface **640**. In addition, video module **620** may buffer video from video cameras **112** in memory. Then, based on predefined criteria, older video that is not considered essential to any alarm signals may be discarded. Video module **620** may also be configured to record video, or portions thereof, on a predetermined basis, which may correspond, for example, to the requirements of the customer. Non-alarm video may be stored for later retrieval by the customer. In one embodiment, the customer or remote user **155** may be able to adjust said predetermined basis including, without limitation, adjusting the recording times, duration, and total length of recordings. In some embodiments, non-alarm video may also be sent to the security system server for storage.

[0082] Video module **620** is also capable of streaming live audio and video from the residence during alarm conditions, as well as for lifestyle viewing over the World Wide Web. If a video camera **112** is analog, video module **620** may

digitize the video before transmitting it. While streaming live media for lifestyle viewing, video module **620** causes alarm control panel **610** and/or speakers **638** to emit an audible tone on a periodic basis. This notification is to address privacy concerns. No firewall or intrusion software is running on video module **620**. Video module **620** accepts network traffic on a limited number of ports (443, 2804, 7070). Typically the IP address of security gateway **115** may be assigned via DHCP.

[0083] Video module **620** may include a PC motherboard, a four-gigabyte hard disk drive, and a digital signal processor. The operating system for video module **620** is embedded Windows NT™. Video entering into video module **620** from security cameras **112** is in either CVBS, NTSC, or PAL format. Video compression may be based on the H.263 format. The audio compression standard for video module **620** may be ADPCM (16 Kbps). When security system **100** is armed, audio and video data are constantly being stored in the video module's memory for potential use as pre-event media. In one particular embodiment, video module **620** contains enough memory to store sixty seconds of pre-alarm video and audio from each camera **112** and microphone **634** in RAM and up to five minutes of audio/video content (per camera **112**) on disk. When an alarm condition occurs, this cached data may be stored more permanently.

[0084] In one embodiment, system **100** may include one or more "smart cameras" that have much of the functionality of the Video Module built in. Specifically, these smart cameras may be operable to perform video capture, compression and storage and to communicate with the security gateway using a home area network, e.g., wireless or powerline. In essence, the smart camera would function as a network appliance that is able to receive instructions from the security gateway to control the session, FPS, quality, bandwidth, support other supervised communication from the gateway, and to transmit video and other information to the security gateway. In one specific embodiment, the smart camera compresses the video using the H.263 standard or better. Preferably, transmission between the camera and security gateway should be secure and reliable, even taking into account the relatively noisy household environment. Optionally, the smart camera is operable to detect motion in the recorded image and send an alarm signal to the security gateway.

[0085] Audio interface **630** performs a similar function to video module **620** but with respect to the audio components. In this embodiment, audio interface **630** includes an audio transmitter, such as a speaker **638**, and an audio receiver, such as a microphone **634**. In a typical configuration, several microphones and speakers would be located throughout the monitored premises. The audio signals picked up by microphone(s) **634** are recorded through audio interface **630**. Audio interface **630** may record the audio or it may transmit the audio to video module **620** for storage. Audio interface **630** may be capable of selecting an individual audio input **634** or any combination of audio inputs **634**. Further, audio interface may play back audio signals through speaker(s) **638**. In some embodiments of the present invention, a two-way streaming audio stream may be initiated between a remote user (such as a remote client or monitoring station personnel) and the premises through audio interface **630**. In one embodiment, the H.323 standard is used for such

two-way streaming audio stream. Advantageously, the two-way audio stream allows the remote user to interact with the premises.

[0086] Communications interface 640 may serve as the gateway between security gateway 115 and one or more communications networks such as the HFC plant 315, PSTN 145, WAN, LAN, and wireless networks. Communications interface 640 may comprise software and hardware including, but not limited to a cable modem, an xDSL modem, and/or a network interface card. In some embodiments, communications interface 640 may be physically separate from the other components of security gateway 115. Regardless of its form, communications interface 640 assists in the communication of data to and security gateway 115 and security system server 131.

[0087] In one particular embodiment, upon detection of an alarm event, the alarm control panel 610 subsystem may initiate a dial-up connection and transmit the alarm to a receiver in security system server 131. More particularly, alarm control panel 610 may seize the telephone line in order to report the alarm to monitoring client 133. Alternatively, such functionality may be performed by communications interface 640. For delivering an alarm notification via the network, the video subsystem 620 may initiate a network connection and transmits the alarm to a receiver in security system server 131. Compressed audio and video data may also be transmitted. To conserve bandwidth, compressed audio streams typically do not exceed 16 kbps, since audio is "toll quality" so that both parties may easily understand each other. Preferably, the video and audio is playable with less than a 1-second shift in synchronization.

[0088] In addition, security gateway 115 may include user interface 650 that can activate or deactivate security system 100. In the illustrative embodiment, user interface 650 is operatively coupled to keypad 657. The user could thereby activate or deactivate system 110 by entering a predetermined code on keypad 657. It will be understood with the benefit of this disclosure of those of skill in the art that any other type of user interface 650 may be used with this invention. For example, security gateway 115 may be activated or deactivated with a remote portable transmitter 655. Wireless remote 655 communicates with user interface 650 via wireless transceiver 652. Additional receivers may be used with the present invention to pick up weak signals. Security gateway 115 is further capable of responding to up to 16 wireless f-button key fobs for changing partition states of security system 100. The key fobs do not use any of the 32 wireless zones, and each key fob is identified to security gateway 115 as a unique user.

[0089] User interface 650 may further include a display for displaying information to the user. Such information may include, without limitation, the current system status, whether an alarm condition has been detected, and whether any components have failed. In addition, other non-system-related information such as the time, date, weather forecasts, and news bulletins may be displayed.

[0090] In some embodiments, alarm control panel 610 supports dialup access by authorized users to remotely configure the system. However, the preferred mode of configuration is through a web site discussed below with respect to FIG. 7.

[0091] FIG. 7 is a more detailed illustration of the various components of the security system server and monitoring

station, according to one embodiment of the present invention. These components may be software programs executable on processor-based devices operable to communicate with one another through LAN 705 and LAN 745, respectively. In one particular embodiment, these components are processor-based devices operating under the Microsoft Windows NT™ operating system. However, it is understood that the present invention is not limited to the illustrated configuration. For example, the components may be implemented as software running on one or more computing devices. Alternatively, the components may be implemented in several devices that may be directly connected via communications interfaces (e.g., serial, parallel, IEEE 1394, IR, RF or USB).

[0092] As shown, security system server 131 may comprise alarm receiver 710, media handler 715, automation system server 720, web interface 732, application server 734 and messaging interface 738.

[0093] Alarm receiver 710 receives the alarm notification and associated information from security gateway 115. The alarm event is then logged and recorded by automation system server 720.

[0094] Alarm events reported by security gateway 115 via the PSTN are also sent to legacy alarm receiver 740. Legacy alarm receiver 740 posts the alarm condition to automation system server 720. Monitoring client 133 retrieves audio and video data from media handler 710. In one particular embodiment, the monitoring client 133 retrieves the audio and video data from media handler 710 using Microsoft's ActiveX component. In other embodiments, other media handling/communications protocols may be used, including, without limitation, custom protocols. The communications protocol is used to transmit audio and video content from media handler 710, submit control messages (for selecting cameras, microphones, and speakers during live feeds), and support Voice Over IP (VOIP) services between the residence and monitoring client 133 during an alarm condition.

[0095] Automation system server 720 is generally configured to store customer data, for example contact information, billing information, passwords, as well as alarm history. Alternatively, some or all of this information be stored in monitoring client 133 or at another remote site. Since this data is usually low bandwidth, dedicated bandwidth may not be necessary. However, it may be desirable for security purposes for it to remain in data center 132. Automation system server 720 may also serve as a workflow system for operators responding to alarm conditions, as well as a log of all monitoring activity. In an exemplary embodiment, automation system server 720 is a database application based on, for example Microsoft SQL Server 7, running under Windows NT. In another embodiment, automation system server 720 may be Monitoring Automation Systems' MASTermind™ server. CMS personnel may interface with automation system server 720 over the network via a client application, which may be built into monitoring client 133.

[0096] Media handler 710 is generally operable to provide several functions. For example, media handler 710 receives and stores video and audio data associated with alarm conditions from security gateway 115 and relays alarm condition data, for example audio and video, to monitoring client 133. Media handler 710 may also be responsible for keeping track of the network addresses for all the security

gateways **115** that are attached. For example, media handler **710** relays alarm conditions reported via TCP/IP from security gateway **115** to automation system server **720**. Media handler **710** may also provide access to audio and video associated with alarm conditions to authorized personnel for a predetermined time period after an alarm condition is detected. Additionally, media handler **710** may relay control and configuration data destined for security gateways **115**. This data may originate either from a CMS operator through monitoring client **133** or from a remote client **155**. The communications protocol between monitoring client **133** and media handler **710** may be proprietary and/or may use standard protocols.

[0097] In most embodiments, the communication channel **134** between the data center and central monitoring station is secure, and accordingly, an unencrypted protocol may be used. In one particular embodiment, an unencrypted ASCII protocol over a TCP/IP connection may be used. In configurations where the connection between the security system server and monitoring client(s) is not secure, it may be desirable to use an encrypted protocol.

[0098] The connection between headend **320** and media handler **710** is preferably a secure communications link. Communication between security gateway **115** and media handler **710** may be conducted over the cable modem infrastructure using, for example, the TCP/IP or UDP protocol. The communications protocol between security gateway **115** and media handler **710** may provide secondary pathways for transmitting alarm notifications, relays configuration information to security gateway **115** (including control messages for arming and disarming partitions, bypassing zones, and selecting cameras, microphones, and speakers for live feeds), uploading pre-event and relevant non-alarm audio and video to media handler **710** during an alarm condition, transmitting live video and audio during an alarm condition, supporting voice over IP (VOIP) services between the residence and monitoring client **133** during an alarm condition, and performing software updates.

[0099] In the illustrative embodiment, upon detection of an alarm condition, security gateway **115** transmits an alarm signal and video corresponding to the alarm condition (this video may be referred to as "alarm video") through headend **320** to media handler **710**, which relays the information to the central station in substantially "real-time." In addition, alarm control panel **610** reports the alarm condition to the security gateway's video module **620**, which uses a network connection to report the alarm condition to media handler **710**, which in turn relays the information to automation system server **720**. In the present disclosure, the term "real-time" transmission is intended to generally mean that no substantive time period events between the captured event and the receipt of alarm video corresponding to the event by monitoring client **133**. In an exemplary embodiment, automation system server **720** will, then, receive two notifications of every alarm condition. Automation system server **720** is capable of recognizing multiple notifications of the same alarm condition, and may ignore all but the first notification. Automation system server **720** transmits the alarm condition data and notification to monitoring client **133**. Monitoring client **133** may use the transmitted alarm video to aid in the determination of whether the alarm signal is a false alarm or not. Advantageously, the real-time transmission permits central monitoring station **136** to respond to

an alarm signal in a timely manner. Timely response may increase the chance of apprehending an intruder, and in the case of life-threatening circumstances, reduce the likelihood of injury or death. Upon verification of the alarm signal, an operator at security system server **131** may take any appropriate action including, but not limited to, contacting the proper authorities, and/or directing security gateway **115** to sound an alarm.

[0100] Messaging interface **738** provides remote clients **155** with the ability to view and edit account information, arm and disarm their security system **100**, and view live and recorded media from their home, all through a network-based interface. In many embodiments, this network-based interface is an Internet website, or a portion of a website. After the remote user is authenticated, application server **734** provides and/or facilitates the features available to remote client **155** through messaging interface **738**. The particular features that are made available are a design decision that may vary based upon several factors, which may include, without limitation, the permissions of the remote user and the type of premises that is monitored. In one specific embodiment, application server **734** may run Dynamo under the Solaris operating system.

[0101] In one particular embodiment, a three-tier architecture may be used to provide such an interface. The first tier may consist of web servers running Internet Information Server (IIS) on Windows NT™, which is responsible for static web content such as images. Requests for dynamic content may be forwarded to application server **734**. Application server **734** generally provides or facilitates all of the functionality that is accessible to remote clients **155**. The third tier is a database tier, that may be provided by automation system server **720**. Data storage may be, for example, a billing database. Authorized users may receive information from the database regarding their account by accessing database server **736**.

[0102] Application server **734** may access automation system server **720** to obtain account information and issue commands ultimately destined for security gateway **115**. Communication between application server **734** and automation system server **720** may take the form of calls to stored procedures defined in the master database maintained by automation system server **720**.

[0103] In one particular embodiment, remote client **155** includes a web-browser-based video client for accessing audio and video data. Typically, the web based video client is a web browser or a plug-in for a web browser. However, in some embodiments (not shown), a custom software program may be used to interface with web interface **732**. Access to web interface **732** requires successful authentication in the form of a username and password. Preferably, all account-specific web content, including the login request, employs the secure HTTP protocol. In one embodiment, each customer may be assigned a GeneralAdministrator (GA) account. GA accounts have full access to their respective associated security gateway **115**. The GA account can also create a limited number of guest accounts that have limited access to their respective associated security gateway **115**. Typically, all account information is stored through automation system server **720**, including surnames and passwords. Web interface **732** retrieves account data from automation system server **720** for display via the Web, by

means of one or more stored procedures. The GA can modify a subset of this account data and update the corresponding entries in automation system server 720.

[0104] After the remote client 155 is authenticated, application server 734 may be configured to allow a remote client 155 to view audio/visual content from security gateway 115, communicate with automation system server 720 to access customer data, and access features of the security system 100. In one embodiment, such features may include, without limitation, arming or disarming security system 100; adjusting sensitivities of sensors 105 (if present); adjusting alarm condition detection sensitivity; remote surveillance; adjusting camera 112 settings; and reviewing alarms and recordings.

[0105] In particular, application server 734 may allow remote client 155 to access media directly from security gateway 115, as discussed below with respect to FIG. 8. In one embodiment, a live feed from the residence is available with the ability to select among cameras 112 and microphones 634. In some embodiments, only video from certain specified cameras is accessible for remote clients. In addition, for privacy purposes, it may be desirable to provide an audible or visual indication that a remote user is receiving a video/audio feed. In some embodiments, application server 734 may be configured to allow a remote client 155 to initiate a two-way streaming audio connection with the security gateway 115 so that the remote client 155 can communicate through the speaker(s) and microphone(s) attached to security gateway 115.

[0106] Security gateway 115 may be configured to limit the transmission of all data (heartbeat, control, video, and audio) to a configurable ceiling relating to the remote client 155 access. Advantageously, this may provide the necessary amount of bandwidth to deliver the requested services, but prevents one user from creating a network bottleneck by requesting too much data at once. In one embodiment, a 128 kbps transmission ceiling is imposed. Access by web based video client 157 to security gateway 115 may be preempted whenever an alarm condition occurs so that CMS personnel have full control over cameras 112 and microphones 634 to respond to the alarm condition.

[0107] Referring now to FIG. 8 a flowchart diagram is shown illustrating operation of the present invention authenticating and allowing remote access to features of security system. In particular, through an associated website (provided through messaging interface 738 and application server 734), remote users may access such features as viewing and editing account information, arming and disarming their security system 100, and viewing live and recorded media from the premises. The web browser/website interface transmits customer account and authorization information.

[0108] In step 905, remote terminal 155 may connect to the website. In an exemplary embodiment, remote terminal 155 may connect using an Internet World Wide Web browser such as Netscape's NAVIGATOR or Microsoft's INTERNET EXPLORER.

[0109] In step 910, remote user 155 provides the website with identification information, for example a username and password. The type of authentication used in remote authorization may take many forms. For example, in one embodi-

ment the media handler may require some sort of a username and password combination. Further, it is to be understood by the disclosure of one of skill in the art that any other procedure suitable for authenticating the identity of remote terminal may be used.

[0110] The website interfaces with authentication system server 720 to verify the identification information in step 920. If the information is determined to not be authentic in step 925, then remote user 155 is denied access. In one outcome of step 925, remote user 155 is denied access to security gateway 115 and its features. Precautions against unauthorized access may be implemented, including, but not limited to, logging incidents of denied access.

[0111] If the information is correct, the user may access the account portion of the website 940. There, the user may change system settings such as username and password, review alarm history, and/or access any other features made available through the application server. It is noted that each user will only be able to access those features commensurate with the permissions associated with the account. Once the user logs out 945, he or she must reconnect to the website and reenter authentication information. Such features are provided through security system server 131.

[0112] In addition, in step 950, media handler 715 provides the remote client 157 with an access token that is digitally signed by the media handler 715. In one particular embodiment, application server 734 accesses media handler 715 to obtain an access token. In this embodiment, the user logs into messaging interface 738, which then allows user to request the web page containing a plug-in. When this occurs, application server 734 queries automation system server 720 for security gateway 115 privileges associated with the user's account (for example, a guest account may be permitted to view only a subset of cameras 112 in the residence). Next, application server 734 submits a request to media handler 715 for an access token. This request encodes the username (for logging purposes), the identity of security gateway 115 to be accessed, the access permissions to be granted for the token, and the desired lifespan of the token, as well as the digital signature of the security system server. The response from media handler 715 contains the token (for example a character string) as well as the current network address for security gateway 115. Application server 734 embeds the access token and security gateway 115 IP address into the web page containing the plug-in and the resulting page is returned to the user's browser.

[0113] The remote client 155 may then connect directly to security gateway 115 and provides security gateway 115 with the access token 955. It is noted that the term "direct connection" means that communications between the remote client 155 and security gateway 115 do not pass through security system server 131. The security gateway 115 inspects the token and is configured to trust valid digital signatures of the security system server. Accordingly, the presence of the token in the web page allows the remote client 157 to access audio and video from the customer's security gateway 115 without the need for all communication to be transmitted through data center 132.

[0114] Accordingly, the remote user may then connect directly to security gateway 115 to perform remote surveillance through security gateway 115, check the system status, initiate a two-way audio conference, and/or any other fea-

tures made available by security gateway **115** and falling within the user's permissions. In some embodiments, only remote surveillance and two-way audio conferencing is made available through security gateway **115**. In these embodiments, all non-media features are provided through security system server **131**.

[**0115**] The remote surveillance feature allows remote user **155** to view all or portions of the video signal from video camera. Depending on the bandwidth of the connection, the video may be of a lower quality than that transmitted to central station for verification of alarm signals. For example, in one embodiment, the video transmitted to remote user **155** may have a lower frame rate, lower resolution, and/or lower color depth. In addition, remote user **155** may be able to configure the quality of the video for remote monitoring.

[**0116**] In addition, depending on the remote user's level of permissions, the remote terminal may access remote features of security gateway **115** directly through headend **320** to reconfigure security system **100**. Once authenticated, remote user **155** may reconfigure some or all of the features of security gateway **115**. These features may include, without limitation, arming or disarming security system **100**; adjusting sensitivities of sensors (if present); adjusting alarm condition detection sensitivity; remote surveillance; adjusting camera settings; and reviewing alarms and recordings. Camera settings may include without limitation pan, tilt, focus, brightness, contrast and zoom.

[**0117**] In some embodiments, media handler **715** may assign a lifespan to an access token. In such cases, after a pre-specified time or event, the access token expires **980** and remote user **155** may not access security gateway **115** any longer. Further, when security system **100** detects that the user has logged out or disconnected from the security system, any access token provided by security system **100** expires.

[**0118**] In step **990**, the remote client **157** is disconnected and the access token expires. In some embodiments, media handler **715** may assign a lifespan to an access token. In such cases, after a pre-specified time, the access token expires and remote user **155** may not access security system **100** any longer. To access to the features of the security gateway, the user must reconnect to the website **905** and provide valid authentication information.

[**0119**] The present invention also overcomes similar problems with personal emergency response systems (PERS) and telemedicine including telehealth. The monitoring clients in these applications can now use the video and alarm to better diagnose the problem. In many ways, alarms from health sensors, emergency panic buttons and the like are similar to alarm sensors in terms of generating false and unwanted alarms.

[**0120**] The present invention can be also used in many different vertical segments within the security industry. In this present invention, the audio and video digitization and processing including compression is centralized at the security gateway. As processors become less expensive and more efficient, these functions can be done at the individual camera or at the audio station. The security gateway may then act as a central communications and controller for the cameras, audio stations and various other sensors.

[**0121**] The preceding examples are included to demonstrate embodiments of the invention. It should be appreci-

ated by those of skill in the art that the techniques disclosed in the examples which follow represent techniques discovered by the inventor to function well in the practice of the invention, and thus can be considered to constitute preferred modes for its practice. However, those of skill in the art should, in light of the present disclosure, appreciate that many changes can be made in the specific embodiments which are disclosed and still obtain a like or similar result without departing from the spirit and scope of the invention.

What is claimed is:

1. A security system comprising:

a security gateway located at a premises, wherein the security gateway is operable to detect an alarm condition and to record video of at least a portion of the premises relating to the alarm condition, said video hereinafter referred to as Alarm Video;

a security system server operatively coupled to the security gateway through a first network, wherein the security gateway is configured to notify the security system server of the alarm condition and to transfer the Alarm Video to the security system server in substantially real time through the first network; and

wherein the security system server is further operatively coupled to the security gateway through a second network, wherein the security gateway is configured to notify the security system server of the alarm condition through the second network.

2. The system of claim 1, wherein the security gateway is further configured to notify the security system server of the alarm condition through the first network substantially simultaneously with notifying the security system server of the alarm condition through the second network.

3. The system of claim 1, wherein the first network is an IP network.

4. The system of claim 1, wherein the first network is an Ethernet-based network.

5. The system of claim 1, wherein the first network comprises the Internet.

6. The system of claim 1, wherein the first network comprises a frame relay network.

7. The system of claim 1, wherein the first network comprises a hybrid-fiber coaxial network.

8. The system of claim 1, wherein the first network comprises a fiber-optic network.

9. The system of claim 1, wherein the first network comprises a DSL network.

10. The system of claim 1, wherein the first network comprises an ATM network.

11. The system of claim 1, wherein the first network comprises a high-speed fixed wireless network.

12. The system of claim 1, wherein the first network comprises a high-speed mobile communications network.

13. The system of claim 1, wherein the second network comprises a public switched telephone network.

14. The system of claim 1, wherein the second network comprises a fixed wireless network.

15. The system of claim 1, wherein the second network comprises a mobile communications network.

16. The system of claim 1, wherein the security gateway is further operable to record audio from at least a portion of the premises relating to the alarm condition, said audio referred to hereinafter as Alarm Audio, and wherein the

security gateway is further configured to transmit said Alarm Audio to the security system server through the second network in substantially real time.

17. The system of claim 1, wherein the security system server is configured to provide notification of the alarm condition to a public safety agency.

18. The system of claim 17, wherein the security system server is further configured to provide the Alarm Video to the public safety agency.

19. The system of claim 1, wherein the security gateway is further operable to record audio from at least a portion the premises relating to the alarm condition, said audio referred hereinafter as Alarm Audio, and wherein the security gateway is further configured to transmit said Alarm Audio to the security system server through the first network in substantially real time.

20. A security system comprising:

a security gateway located at a premises,

wherein the security gateway is operable to detect an alarm condition and to record video of at least a portion of the premises relating to the alarm condition, said video hereinafter referred to the Alarm Video,

wherein the security gateway further comprises a network interface, and

wherein the network interface is configured to connect the security gateway to a cable headend through a first network, wherein said first network is a hybrid-fiber-coaxial network; and

a security system server configured to connect to the cable headend through a second network,

wherein the security gateway is configured to notify the security system server of the alarm condition and to transfer the Alarm Video to the security system server in substantially real time.

21. The system of claim 20, wherein the second network is a dedicated bandwidth network.

22. The system of claim 20, wherein the second network comprises a frame relay network.

23. The system of claim 20, wherein the second network comprises an ATM network.

24. The system of claim 20, wherein the second network comprises a managed IP connection having quality of service.

25. The system of claim 20, wherein the security gateway is operatively coupled to the security system server through a third network, the security gateway being further configured to notify the security system server of the alarm condition through the third network.

26. The system of claim 25, wherein the third network comprises a public switched telephone network.

27. The system of claim 25, wherein the third network comprises a fixed wireless network.

28. The system of claim 25, wherein the third network comprises a mobile communications network.

29. The system of claim 20, wherein the security gateway is further operable to record audio from at least a portion the premises relating to the alarm condition, said audio referred hereinafter as Alarm Audio, and wherein the security gate-

way is further configured to transmit said Alarm Audio to the security system server through the second network in substantially real time.

30. The system of claim 20, wherein the security system server is configured to provide notification of the alarm condition to a public safety agency.

31. The system of claim 30, wherein the security system server is further configured to provide the Alarm Video to the public safety agency.

32. A security system for providing security monitoring services for a customer comprising:

a security gateway located at a premises designated by the customer,

wherein the security gateway is operable to detect an alarm condition and to record video of at least a portion of the premises relating to the alarm condition, said video hereinafter referred to as the Alarm Video,

wherein the security gateway further comprises a network interface, and

wherein the network interface is configured to connect the security gateway to a DSLAM through a first network, wherein the first network is a DSL network; and

a security system server connected to the DSL through a second network, wherein the security gateway is configured to notify the security system server of the alarm condition and to transfer the Alarm Video to the security system server in substantially real time.

33. The system of claim 32, wherein the second network is a dedicated bandwidth network.

34. The system of claim 32, wherein the second network is a frame relay network.

35. The system of claim 32, wherein the second network is an ATM network.

36. The system of claim 32, wherein the second network comprises a managed IP connection having quality of service.

37. The system of claim 32, wherein the security gateway is operatively coupled to the security system server through a third network, the security gateway being further configured to notify the security system server of the alarm condition through the third network.

38. A security system for providing security monitoring services comprising:

a security gateway located at a premises designated by a user, wherein the security gateway is operable to detect an alarm condition and to record video of at least a portion of the premises relating to the alarm condition, said video hereinafter referred to the Alarm Video;

a security system server operatively coupled to the security gateway and a data center, the data center comprising:

a user information database, comprising data about the user, said data referred to hereinafter as User Data,

wherein the security gateway is configured to notify the data center of the alarm condition and to transfer the Alarm Video to the data center in substantially real time,

wherein the security system server is operable to associate the Alarm Video with at least a portion of the User Data, said portion of the User Data referred to hereinafter as Associated User Data, and

a monitoring client operatively coupled to the monitoring client, wherein the data center is configured to transfer the notification of the alarm condition, the Alarm Video and Associated User Data to the monitoring client, and

wherein the monitoring client is configured to display at least a portion of the Alarm Video and the Associated User Data on the monitoring client.

39. The system of claim 38, wherein the monitoring client is at a central monitoring station.

40. The system of claim 39, wherein the security gateway is further operatively coupled to a central monitoring server at the central monitoring station, and wherein the security gateway is configured to transfer a notification of the alarm condition to the central monitoring server.

41. The system of claim 38, wherein the data center is further operable to store the notification of the alarm condition in the user information database.

42. The system of claim 38, wherein the data center is further operable to store the Alarm Video in the user information database.

43. A security system for providing security monitoring services for a plurality of users comprising:

a plurality of security gateways, each located at a premises, wherein each security gateway is operable to detect an alarm condition and to record video of at least a portion of its respective premises relating to the alarm condition, said video hereinafter referred to the Alarm Video;

a security system server operatively coupled to the plurality of security gateways, the security system server comprising a user information database, comprising data about each of the plurality of users, said data referred to hereinafter as User Data,

wherein each security gateway is configured to notify the security system server of the alarm condition and to transfer the Alarm Video to the security system server in substantially real time,

wherein the security system server is operable to associate the Alarm Video with at least a portion of the User Data, said portion referred to hereinafter as Associated User Data; and

a monitoring client operatively coupled to the security system server, and wherein the security system server is configured to transfer the notification of the alarm condition, the Alarm Video and Associated User Data to the monitoring client, and

wherein said monitoring client is configured to display at least a portion of the Alarm Video and the Associated User Data.

44. The system of claim 43, wherein the security system server is further operable to store the notification of the alarm condition in the user information database.

45. The system of claim 43, wherein the security system server is further operable to store the alarm video in the user information database.

46. The system of claim 43, wherein the monitoring client is at a central monitoring station.

* * * * *