

CERTIFICATE OF TRANSLATION ACCURACY

I am a specialized translator, reviewer, and/or project coordinator specializing in translating Korean, Japanese and Chinese to English and vice versa.

I served as Chief Examiner of the certified court interpreter test for the State of California and as a contract translator and interpreter for various federal agencies through the U.S. Department of State for more than a decade. I worked as an instructor at the University of California at Berkeley, and the Middlebury Institute of International Studies at Monterey (MIIS) Graduate Program in Translation.

I have more than 30 years of experience translating thousands of technical, legal, and business documents from Korean to English submitted to, among others, Korean judicial authorities, U.S. federal courts, the U.S. International Trade Commission (ITC), and the USPTO Patent Trial and Appeal Board (PTAB).

I certify that I translated the document, identified below, from Korean to English. I also certify that this is a true, correct, and complete translation of the corresponding source text to the best of my knowledge and ability.

WO2017175886A1

I certify under penalty of perjury that the foregoing is true and correct.

Executed this 19th day of December 2025 in Contra Costa County of the State of California.

By: _____

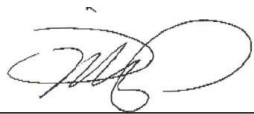

Alex N. Jo
Member, ATA

(12) International Application Published under the Patent Cooperation Treaty (PCT)

(19) World Intellectual Property Organization

International Bureau

(43) International Appl. Publication Date

Oct. 12, 2017 (10.12.2017)



(10) International Publication No.

WO 2017/175886 A1

(51) International Patent Classification:

H01Q 1/24 (2006.01) H01Q 9/04 (2006.01)

H01Q 1/38 (2006.01) H02J 17/00 (2006.01)

H01Q 1/52 (2006.01) H04B 5/00 (2006.01)

(21) International Application No.: PCT/KR2016/003521

(22) International Filing Date: Apr. 5, 2016 (04.05.2016)

(25) Filing Language: Korean

(26) Publication Language: Korean

(71) Applicant: EMW CO., LTD. (EMW CO., LTD. [in English]) [KR/KR]; 155, Namdongseo-ro, Namdong-gu, Incheon, 21695 (Gojan-dong), Incheon (KR).

(72) Inventor(s): SEONG, Won-Mo (SEONG, Won-Mo [in English]); (Pyeongchon-dong, Ggummaeul Woosung Apartments #204-601) 34 Burim-ro, Dongan-gu, Anyang-si, Gyeonggi-do (KR) (zip) 14101. KIM, Gi-Ho (KIM, Gi-Ho [in English]); (Haan-dong, Haan 9 Complex Jugong Apartments #915-402) 364 Haan-ro, Gwangmyeong-si, Gyeonggi-do (KR) (zip)14246. KIM, Ui-Sheon (KIM, Ui-Sheon [in English]); 15825 33 Sanboncheon-ro, 709 Dong 1902 Ho (Sanbon-dong, Wooreuk Apartment), Gyeonggi-do (KR). KIM, Nam-II (KIM, Nam-II [in English]); 306 Sinwon-ro, Yeongtong-gu, Suwon-si, Gyeonggi-do (KR) (zip) 16675.

OH, Jung-Han (OH, Jung-Han [in English]); (Maetan 3-dong, Imgwang Apartments #1-104) 316 Dongsuwon-ro, Yeongtong-gu, Suwon-si, Gyeonggi-do, Gyeonggi-do (KR) (zip) 16546. Baek, In-Seung (Baek, In-Seung [in English]); (Dongwang Villa #2) 2, 384beon-gil, Jingeononam-ro, Jingeon-eup, Namyangju-si, Gyeonggi-do (KR) (zip) 12129. Hwang, Bo-Mi (Hwang, Bo-Mi [in English]); 14, 101beon-gil, Seoksan-ro (Ganseok-dong), Namdong-gu, Incheon, 21550, Incheon (KR) (zip).

(74) Agent: DOOHO IP LAW FIRM (DOOHO IP LAW FIRM [in English]); (Seocho-dong, Daehyeon Blue Tower, F1, F7) Gangnam-daero 51-gil, Seocho-gu, Seoul (KR) (zip) 06628.

(81) Designated countries (unless otherwise indicated, for all available nationally protected rights): AE, AG, AL, AM, AO, AT, AU, AZ, BA, BB, BG, BH, BN, BR, BW, BY, BZ, CA, CH, CL, CN, CO, CR, CU, CZ, DE, DK, DM, DO, DZ, EC, EE, EG, ES, FI, GB, GD, GE, GH, GM, GT, HN, HR, HU, ID, IL, IN, IR, IS, JP, KE, KG, KN, KP, KR, KZ, LA, LC, LK, LR, LS, LU, LY, MA, MD, ME, MG, MK, MN, MW, MX, MY, MZ, NA, NG, NI, NO, NZ, OM, PA, PE, PG, PH, PL, PT, QA, RO, RS, RU, RW, SA, SC, SD, SE, SG, SK, SL, SM, ST, SV, SY, TH, TJ, TM, TN, TR, TT, TZ, UA, UG, US, UZ, VC, VN, ZA, ZM, ZW.

[See continued pages]

(54) Title: ANTENNA STRUCTURE [in English]

(54) Title of the Invention: ANTENNA STRUCTURE [in Korean]

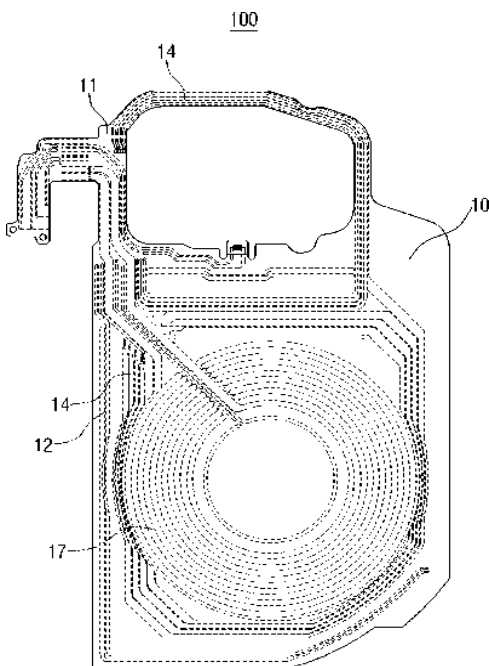

(57) Abstract: The present invention relates to an antenna structure comprising: a substrate having a predetermined shape; and a shielding sheet laminated on the top surface of the substrate, wherein the top surface or the bottom surface of the substrate has a WPC pattern formed thereon, and the antenna structure further comprises a thermistor which is formed on the top surface or the bottom surface of the substrate so as to measure the temperature of the WPC pattern. According to the present invention, an NFC antenna, an MST antenna, and a WPC antenna are formed together in one substrate so as to reduce the overall size of the antenna structure, and thus it is possible to efficiently use the internal space of a mobile communication terminal; even when an NFC antenna, an MST antenna, and a WPC antenna are formed together in one substrate, the individual antennas can obtain optimal performance without interference therebetween; unlike a conventional antenna structure comprising a plurality of sheets, one nanocrystal sheet is used, so that the thickness of the antenna structure can be significantly reduced; and when the antenna structure is heated to a predetermined temperature or higher, the wireless charging function is blocked by a built-in thermistor, so that unnecessary damage can be prevented. [in English]

(57) Abstract: [in Korean]

[See continued pages]

WO 2017/175886 A1



(84) Designated countries (unless otherwise indicated, for all available regionally protected rights): ARIPO (BW, GH, GM, KE, LR, LS, MW, MZ, NA, RW, SD, SL, ST, SZ, TZ, UG, ZM, ZW), Eurasia (AM, AZ, BY, KG, KZ, RU, TJ, TM), Europe (AL, AT, BE, BG, CH, CY, CZ, DE, DK, EE, ES, FI, FR, GB, GR, HR, HU, IE, IS, IT, LT, LU, LV, MC, MK, MT, NL, NO, PL, PT, RO, RS, SE, SI, SK,

SM, TR), OAPI (BF, BJ, CF, CG, CI, CM, GA, GN, GQ, GW, KM, ML, MR, NE, SN, TD, TG).

This publication:

— includes an international search report (Article 21(3) of the Treaty).

The present invention relates to an antenna structure comprising: a substrate having a predetermined shape; and a shielding sheet laminated on the top surface of the substrate, wherein the top surface or the bottom surface of the substrate has a WPC pattern formed thereon, and the antenna structure further comprises a thermistor which is formed on the top surface or the bottom surface of the substrate so as to measure the temperature of the WPC pattern. According to the present invention, an NFC antenna, an MST antenna, and a WPC antenna are formed together in one substrate so as to reduce the overall size of the antenna structure, and thus it is possible to efficiently use the internal space of a mobile communication terminal; even when an NFC antenna, an MST antenna, and a WPC antenna are formed together in one substrate, the individual antennas can obtain optimal performance without interference therebetween; unlike a conventional antenna structure comprising a plurality of sheets, one nanocrystal sheet is used, so that the thickness of the antenna structure can be significantly reduced; and when the antenna structure is heated to a predetermined temperature or higher, the wireless charging function is blocked by a built-in thermistor, so that unnecessary damage can be prevented. [in Korean]

Specification

Title of the Invention: Antenna structure

Technical Field

- [1] The present invention relates to an antenna structure, and more particularly to a composite antenna structure in which an NFC pattern, an MST pattern, and a WPC pattern are all formed at once on a single substrate.

Background Art

- [2] With the widespread adoption of mobile communication devices, more specifically smartphones, recent smartphones are equipped with a variety of features to provide convenience to users, including NFC (Near Frequency Communication) and MST (Magnetic secure Transmission) for easy payment, and WPC (Wireless Power Charge), which overcomes the limitations of wired charging for mobile devices.
- [3] With NFC and MST on mobile devices, users no longer need to take their credit cards out of their wallets to make payments, and wireless charging allows them to use their devices without cables while they are charging. All of these features are made possible by the antennas mounted on the mobile phone.
- [4] On another note, with the recent trend of thinner and smaller mobile devices, the space available for mounting antennas is also shrinking, and research on mounting multiple antennas on a single substrate continues. In the case of mounting multiple antennas all at once on a single substrate, there are many challenges to solve, ranging from space-efficient placement to minimizing interference between antennas. Furthermore, when three or more antennas are mounted all at once on a single substrate, these challenges are exacerbated by the fact that two of the antennas are necessarily on the same surface of the substrate.
- [5] Therefore, through this invention, there is proposed a new and advanced antenna structure that can simultaneously form NFC antenna, MST antenna, and WPC antenna on one single substrate through efficient space utilization to provide NFC and MST functions and wireless charging functions for user convenience, while deriving optimal performance.

[6] [Prior Art References]

[7] [Patent Literature]

[8] Republic of Korea (KR) Published Patent Application Gazette No. 10-2015-0131925 (Nov. 25, 2015)

Detailed Description of the Invention

Technical Problem To Be Solved

- [9] An object of the present invention is to provide an antenna structure capable of simultaneously forming an NFC antenna, an MST antenna, and a WPC antenna on a single substrate through efficient space utilization.

- [10] Furthermore, another object of the present invention is to provide an antenna structure that can form an NFC antenna, an MST antenna, and a WPC antenna all at once on a single substrate to derive optimal performance of each individual antenna.
- [11] Meanwhile, the technical problems that the present invention aims to solve are not limited to those mentioned above, and various technical problems may be derived from the content described below within the scope that is apparent to a person of ordinary skill in the art.

Means to Solve the Problem

- [12] An antenna structure according to one embodiment of the present invention comprises a substrate of a predetermined shape and a shielding sheet laminated on a top surface of the substrate, the shielding sheet comprising a nanocrystal layer. According to the present invention, an NFC antenna, an MST antenna, and a WPC antenna can be formed all at once at a single substrate to reduce the overall size of the antenna structure, thereby efficiently utilizing the internal space of a mobile communication terminal, and by forming an NFC antenna, an MST antenna, and a WPC antenna on a single substrate, it is possible to derive optimal performance of the individual antennas without interference between the antennas. In addition, unlike conventional antenna structures that include multiple sheets, the thickness of the antenna structure can be strikingly reduced by using a single nanocrystal sheet, and the built-in thermistor blocks the wireless charging function when the antenna structure rises above a certain temperature, thus preventing unnecessary damage.
- [13] Furthermore, the nanocrystal layer may be one in which the first to the Nth (N is a positive integer) nanoribbons are laminated via an adhesive.
- [14] Further, a buffer may be formed on the bottom surface of the substrate to prevent scratches caused by contacting the glass of the terminal on which the antenna structure is mounted.
- [15] It may further comprise an attractor laminated between the substrate and the shielding sheet.
- [16] Further, at least one of the NFC pattern, the MST pattern, and the WPC pattern may be formed on the top surface or the bottom surface of the substrate, and the attractor may be applied to a non-patterned portion of the substrate.
- [17] Furthermore, the NFC pattern, the MST pattern, and the WPC pattern may be spaced apart on the top surface or the bottom surface of the substrate.
- [18] Further, the NFC pattern, the MST pattern, and the WPC pattern may be formed in order from the outer periphery of the substrate inwards, and the NFC pattern may be spaced apart and formed as an extension inside the WPC pattern.
- [19] Further, the lateral length of the MST pattern may be less than or equal to the diameter of the WPC pattern.
- [20] Further, the longitudinal length of the MST pattern may be greater than or equal to the diameter of the WPC pattern.

[21] Further, the longitudinal end of the MST pattern may further comprise a bend that is partially curved along the shape of the WPC pattern.

[22] Further, the substrate may comprise a predetermined shaped extension formed on one side, wherein the MST pattern may be extendedly formed.

[23] Further, on the extension, terminals of the NFC pattern, MST pattern, and WPC pattern may be exposedly formed.

[24] The shielding sheet may further comprise a graphite sheet laminated to the top surface of the shielding sheet.

Effect of the Invention

[25] According to the present invention, an NFC antenna, an MST antenna, and a WPC antenna can be formed all at once at a single substrate to reduce the overall size of the antenna structure, thereby efficiently utilizing the internal space of a mobile communication terminal.

[26] In addition, the formation of NFC antennas, MST antennas, and WPC antennas all at once on a single substrate has the effect of deriving optimal performance of individual antennas without interference between them.

[27] In addition, unlike conventional antenna structures that include multiple sheets, the thickness of the antenna structure can be reduced by using a single nanocrystal sheet. By utilizing a single nanocrystal sheet, the thickness of the antenna structure can be strikingly reduced.

[28] In addition, by embedding a thermistor, the wireless charging function is blocked when the antenna structure rises above a certain temperature, thus preventing unnecessary damage.

[29] The effects of the present invention are not limited to those mentioned above, but may include various effects within the scope that will be apparent to a person of ordinary skill in the art from the description hereunder.

Brief Description of the Drawings

[30] FIG. 1 is a drawing showing a cross-sectional view of an antenna structure according to one embodiment of the present invention.

[31] FIG. 2 is a drawing showing a cross-sectional view of a nanocrystal layer.

[32] FIG. 3 is a drawing showing a cross-sectional view of an antenna structure with an attractor added.

[33] FIG. 4 is a drawing showing the specific lamination positions of the attractor.

[34] FIG. 5 is a drawing showing the antenna patterns formed on the top surface of the substrate.

[35] FIG. 6 is a drawing showing the antenna patterns formed on the bottom surface of the substrate.

[36] FIG. 7 is a drawing showing an NFC pattern formed on the top surface of the substrate.

[37] FIG. 8 is a drawing showing an NFC pattern formed on the bottom surface of the substrate.

[38] FIG. 9 is a drawing showing an MST pattern formed on the top surface of a substrate.

[39] FIG. 10 is a drawing showing an MST pattern formed on the bottom surface of a substrate.

[40] FIG. 11 is a drawing showing an MST pattern and a WPC pattern formed on the top surface of the substrate.

[41] FIG. 12 is a drawing showing a WPC pattern formed on the top surface of the substrate.

- [42] FIG. 13 is a drawing showing a WPC pattern formed on the bottom surface of the substrate.
- [43] FIG. 14 is a drawing showing terminals formed on an extension of the board.
- [44] FIG. 15 is a drawing showing a thermistor formed on the substrate.
- [45] FIG. 16 is a drawing showing a cross-sectional view of the antenna structure with a graphite sheet added.
- [46] FIG. 17 is a drawing showing a flowchart illustrating a method of manufacturing an antenna structure, which is another embodiment of the present invention.

Embodiments of the Invention

- [47] Hereinafter, some embodiments of the present invention are described in detail with reference to the illustrative drawings. The embodiments described are provided to facilitate easy understanding of the technical ideas of the present invention by those skilled in the art and are not intended to limit the invention, and detailed descriptions of related known configurations or features are omitted where it is believed that such detailed descriptions would obscure the essence of the invention.
- [48] It should also be noted that the accompanying drawings are schematized to illustrate embodiments of the present invention and may differ from the form in which they are actually implemented, and that in assigning reference numerals to components in each drawing, it is intended that identical components have the same numeral symbols as far as possible, even though they may be shown in different drawings.
- [49] Furthermore, the expression "including" certain components is an expression that simply refers to the presence of such components as an "open-ended expression" and should not be understood to exclude additional components.
- [50] On another note, the NFC pattern, MST pattern, and WPC pattern referred to in the following specification can be broadly viewed as NFC antennas, MST antennas, and WPC antennas having 13.56 MHz, 100KHz, and 125KHz as available frequencies, respectively.
- [51] FIG. 1 is a drawing showing a cross-sectional view of an antenna structure 100, according to one embodiment of the present invention.
- [52] The antenna structure 100 may include a substrate 10 and a shielding sheet 20, wherein the shielding sheet 20 may include a nanocrystal layer 25. However, this is only one embodiment, and it is certainly understood that some configurations may be added or deleted as needed.
- [53] The substrate 10 may exhibit a predetermined shape, wherein the predetermined shape may vary depending on the location of the cellular terminal on which the antenna structure 100 is mounted. For example, if the antenna structure 100 is mounted on top of a battery, the substrate 10 may have the same or similar shape as the shape of the battery cross-section, and if it is mounted behind a glass, it may have the same or similar shape as the shape of the glass cross-section.
- [54] Since the antenna patterns to be described later are to be formed on such a substrate 10, a conventional printed circuit board (PCB) can be used, or a flexible printed circuit board (FPCB),

which has recently been utilized in various ways due to its flexibility, can be used. Where FPCBs are used, they are thinner than PCBs, making them more desirable in terms of space utilization.

- [55] On another note, Meanwhile, a cushioning buffer is formed on the bottom surface of the substrate 10 to prevent scratches caused by contact with the battery or glass of the mobile communication terminal device onto which the antenna structure 100 is mounted. Here, the cushioning buffer may utilize a known composition; for example, a sponge or paper may be used. Regardless of its name, any material capable of preventing scratches caused by contact may be used as the cushioning buffer.
- [56] The shielding sheet 20 is adhesively laminated to the top surface of the substrate 10, and the shielding sheet 20 may include a nanocrystal layer 25. Here, the nanocrystal layer 25 is a composition that can replace the ferrite sheet and the amorphous sheet in conventional NFC and WPC antenna composites, and the effect of thinning the overall thickness of the antenna structure 100 can be obtained by composing a plurality of sheets into a single layer.
- [57] On another note, a cover film is laminated on the top surface of the nanocrystal layer 25, which plays a role in protecting the surface of the nanocrystal layer 25.
- [58] Describing the nanocrystal layer 25 in more detail, the nanocrystal layer 25 may represent a structure in which the first to the Nth (wherein N is a positive integer) nanoribbons are stacked through an adhesive. FIG. 2 is a drawing showing five nanoribbons stacked via an adhesive, and it can be seen that the nanoribbons have a thickness of about 20 μm , and the adhesive has a thickness of about 5 μm , so that the entire nanocrystal layer 25 has a thickness of about 120 μm . Meanwhile, the top layer of nanoribbons may be laminated with the cover film described above to protect the surface of the nanocrystal layer 25, the cover film having a thickness of about 15 μm .
- [59] The nanocrystal layer 25 is preferably fabricated to exhibit a composition content of 93.4% Fe, 4.86% Si, and 1.74% Cu, although some other components may be included as needed, and the composition content may be adjusted.
- [60] FIG. 3 is a drawing showing a cross-sectional view of an antenna structure 100 having an attractor 30 added to it, according to one embodiment of the present invention.
- [61] The attractor 30 is configured to prevent the magnetic field from spreading outward due to saturation of the magnetic body and the resulting decrease in communication efficiency (a type of communication failure), and should be formed of a metal component having a high saturation magnetization value to facilitate magnetic flow, preferably formed of a metal containing an amorphous component.
- [62] On another note, since the attractor 30 is laminated through an adhesive between the substrate 10 and the shielding sheet 20, and has its own thickness, a problem of increased thickness may occur when it is laminated on the top surface of the substrate 10. In this case, the problem of increased thickness can be solved by laminating the attractor 30 to a portion where the antenna patterns, to be described later herein, are not formed. Furthermore, since the attractor 30 is laminated on a portion where the antenna patterns are not formed, it is not necessary to form the attractor 30 in a width that covers the entire substrate 10, which may adversely affect the performance of the antenna complex 100 due to excessively high saturation magnetization values. Therefore, it is preferred to form it on a portion alone. Referring to FIG. 4, specific stacking locations of the attractors can be seen.

- [63] FIG. 5 is a drawing showing antenna patterns formed on the top surface of a substrate 10 comprising an antenna structure 100 according to one embodiment of the present invention, and FIG. 6 is a drawing showing antenna patterns formed on the bottom surface. While the antenna patterns are preferably formed as shown in FIGS. 5 and 6, this is only one embodiment that enables the antenna structure 100 according to one embodiment of the present invention to produce optimal performance, and of course, the shape and layout arrangement of the antenna patterns may be varied as needed.
- [64] At least one of the NFC pattern 12, the MST pattern 14, and the WPC pattern 17 is formed on the top surface or the bottom surface of the substrate 10, and it is preferable to form all of the NFC pattern 12, the MST pattern 14, and the WPC pattern 17 at once in order to perform both payment and wireless charging functions. Specifically, the NFC pattern 12, the MST pattern 14, and the WPC pattern 17 are formed in order from the outer periphery of the substrate 10 to inwards at predetermined intervals, as will be described below with reference to FIGS. 7 through 12.
- [65] FIG. 7 is a drawing showing the NFC pattern 12 formed on the top surface of the substrate 10, and FIG. 8 is a drawing showing the NFC pattern 12 formed on the bottom surface thereof.
- [66] Referring to FIG. 7, it can be seen that the NFC pattern 12 is formed horizontally at the 6 o'clock position of the substrate 10, with one end partially bent from there, formed longitudinally at the 9 o'clock position, and circularly at the center. Referring to FIG. 8, it can be seen that the NFC pattern 12 is formed horizontally at the 12 o'clock position of the substrate 10, at the 6 o'clock position in a lateral direction and with one end partially bent, at the 9 o'clock and 3 o'clock positions in a longitudinal direction, and circularly at the center. In this case, an NFC pattern 12 is formed longitudinally at the 3 o'clock position on the top surface of the substrate 10. However, an NFC pattern 12 is formed longitudinally at the 3 o'clock position on the bottom surface of the substrate 10, connecting to the central circular pattern on the top surface of the substrate 10. This prevents any functional issues and actually allows the thickness at the 3 o'clock position and the center to be reduced. Here, the centrally circular NFC pattern 12 is spaced apart and extended formed inwards relative to the WPC pattern 17 described later. This can provide groundbreaking improvements in the NFC performance.
- [67] In FIGS. 7 and 8, the NFC pattern is illustrated with one turn of a conductive line, but this is for illustrative purposes only, and of course, it can be formed with a plurality of conductive lines. For example, two turns of conductive lines can be formed laterally at 12 o'clock and 6 o'clock, and two turns of conductive lines can be formed longitudinally at 9 o'clock and 3 o'clock. This is to secure a length value for the NFC pattern 12, and it is acceptable to form it with any number of turns as long as the total length value is secured.
- [68] FIG. 9 is a drawing showing the MST pattern 14 formed on the top surface of the substrate 10, and FIG. 10 is a drawing showing the MST pattern 14 formed on the bottom surface.
- [69] The MST pattern 14 is formed, spaced apart from the NFC pattern 12 formed on the top and bottom surfaces of the substrate 10, without contacting it inward. The MST pattern 14 may likewise be formed with a sufficient number of turns to ensure its length value.

- [70] In the case of the MST pattern 14, there is a peculiarity in the lengths of the lateral and longitudinal directions, wherein the length of the lateral direction is less than or equal to the diameter of the WPC pattern 17 to be described herein later, and the length of the longitudinal direction is greater than or equal to the diameter of the WPC pattern 17. This can be seen specifically with reference to FIG. 11, wherein a bend 15 is formed in a portion of the MST pattern 14 in the longitudinal direction because the lateral length of the MST pattern 14 is less than or equal to the diameter of the WPC pattern 17. This is to prevent that if the bend 15 is not formed in the longitudinal direction of the MST pattern 14, it would overlap with the WPC pattern 17, However, the bend 15 is formed, and therefore an additional length value can be obtained. Furthermore, the present invention provides a way to utilize space by efficiently positioning the antenna within the constraints of a given substrate 10 size.
- [71] Furthermore, since the longitudinal length of the MST pattern 14 is greater than or equal to the diameter of the WPC pattern 17, it is not necessary for the bend 15 to be formed on a portion of the MST pattern 14 in the lateral direction, but this is only one embodiment, and the longitudinal length of the MST pattern 14 may also be less than or equal to the diameter of the WPC pattern 17, in which case the bend 15 may be formed on a portion of the MST pattern 14 in the lateral direction. In other words, the length of the MST pattern 14 in the lateral direction or the length in the longitudinal direction may be more than or less than the diameter of the WPC pattern 17, and if it is "less than," the bend 15 may be formed in a part of the MST pattern 14 to prevent overlap with the WPC pattern 17 and to secure the length value. For example, if the size of the substrate 10 is small, it may be necessary to form bends 15 in both the lateral and longitudinal directions to prevent overlap with the WPC pattern 17 and to secure the length value of the MST pattern 14.
- [72] Meanwhile, since the MST pattern (14) is for credit card replacement payments, which are rapidly gaining adoption, the direction in which a mobile communication terminal is brought into proximity with a POS device during payment may vary depending on the user. For example, one user might approach the POS terminal with the mobile communication terminal held horizontally, while another user might tilt the top or bottom of the mobile communication terminal when approaching the POS terminal. In other words, if payment can only be performed by approaching the mobile communication terminal to the POS terminal in a specific orientation, users will inevitably feel inconvenienced, necessitating a solution. This will be described below.
- [73] The substrate 10 may include a predetermined shaped extension 11 on one side. The extension 11 is shown in the aforementioned figures as a portion of the substrate 10 including a hole at the 12 o'clock position, but need not necessarily include a hole. Such extension 11 may have an extended MST pattern 14 formed thereon, which allows payment to be performed by covering all directions, even if the user tilts the top or bottom of the mobile device to approach the POS terminal. For example, if the extension 11 is disposed on the top side of the mobile communication device, if the user approaches the POS terminal by tilting the top side of the mobile communication device, payment will be performed by the MST pattern 14 formed on the extension 11, and if the extension 11 is disposed on the bottom surface of the mobile communication device, if the user approaches the POS terminal by tilting the bottom surface of the mobile communication device, payment will be performed by the solution to the MST pattern 14 formed on the extension 11. On another note,

if the user approaches the POS terminal by tilting the mobile communication device to the left or right, there is no problem because payment is performed by the MST pattern 14 formed on the main body of the substrate 10. On another note, the MST pattern 14 formed on the extension 11 may be extendedly formed from the MST pattern 14 formed on the main body of the substrate 10, but it may also be formed separately from it and perform a function through coupling.

- [74] FIG. 12 is a drawing showing a WPC pattern 17 formed on the top surface of the substrate 10, and FIG. 13 is a drawing showing a WPC pattern 17 formed on the bottom surface.
- [75] The WPC pattern 17 generally has a circular shape that winds inward, and the higher the number of turns, the higher the efficiency of wireless charging. Therefore, it is desirable to have as many turns as possible within a given size of the substrate 10. The orientation of the WPC pattern 17 and its relationship to the lateral and longitudinal orientation of the MST pattern 14 surrounding it has been described earlier.
- [76] On another note, the NFC pattern 12 is spaced apart and extendedly formed inside the innermost conductive line of the WPC pattern 17, which can provide groundbreaking improvements in the performance of NFC, as described above.
- [77] The NFC pattern 12, the MST pattern 14, and the WPC pattern 17 described so far may have their respective terminals 13, 16, and 18 exposedly formed through the extension 11 of the substrate 10, as shown in FIG. 14, and may be electrically connected with internal components of a mobile communication terminal. Furthermore, the antenna structure 100 according to one embodiment of the present invention may further comprise a thermistor 40 on the substrate 10, which is capable of measuring the temperature of the substrate 10, more specifically the temperature of one or more of the NFC pattern 12, the MST pattern 14, and the WPC pattern 17. However, the thermistor 40 is not necessarily formed on the top surface of the pattern. The terminals 43 of such a thermistor may also be exposedly formed through the extension 11, which may be electrically connected to internal components of the cellular terminal to block the wireless charging function if the temperature of the WPC pattern 17 rises above a certain temperature. Referring to FIG. 15, a thermistor 40 formed on the top surface of the substrate 10 can be seen, but this is merely one embodiment and the position of the thermistor 40 can be varied as needed.
- [78] Furthermore, the top surface of the shielding sheet 20 may be laminated with a further graphite sheet 50. Referring to FIG. 16, it can be seen that effective heat dissipation is enabled by the graphite sheet 50, which has good thermal conductivity, although other types of sheets with good thermal conductivity other than the graphite sheet 50 can be utilized as well. While the graphite sheet 50 is described herein as being formed on the top surface of the shielding sheet 20, it is not necessarily limited thereto and may also be formed on the bottom surface of the substrate 10.
- [79] On another note, the antenna structure 100 according to one embodiment of the present invention can be realized by another embodiment, an antenna structure manufacturing method, which includes the same technical features. Hereinafter, it will be described with reference to FIG. 17.

- [80] First, an antenna pattern is formed on the top or bottom surface of the substrate, 10 (S210). Here, the substrate, 10, can be a PCB or FPCB, and the antenna pattern can form one or more of an NFC pattern, 12, an MST pattern, 14, and a WPC pattern, 17. However, to perform both payment and wireless charging functions, it is desirable to form all of them at once. Pattern formation may utilize known antenna pattern formation methods.
- [81] Then, an attractor 30 is laminated on the top surface of the substrate 10 (S220). Here, the attractor is configured to prevent the magnetic field from spreading outward due to saturation of the magnetic material and the resulting decrease in communication efficiency (a type of communication failure), and should be formed from a metallic component having a high saturation magnetization value to facilitate magnetic flow, preferably a metal containing an amorphous component, to prevent an increase in thickness by laminating it to a portion where the antenna pattern is not formed in the above step S210.
- [82] Once the attractor 30 has been laminated, the shielding sheet 20 is then laminated on top of the attractor 30 (S230). Here, the shielding sheet 20 may include the nanocrystal layer 25, and the effect of thinning the overall thickness of the antenna complex 100 by the nanocrystal layer 50 may be obtained.
- [83] In more detail, the nanocrystal layer 25 may represent a structure in which the first to the Nth (where N is a positive integer) nanoribbons are laminated via an adhesive, and because it is a structure laminated via an adhesive, it may be fabricated using either a top-to-bottom lamination method or a bottom-to-top lamination method.
- [84] The nanocrystal layer 25 is preferably fabricated to exhibit a composition content of 93.4% Fe, 4.86% Si, and 1.74% Cu, although, of course, some other components may be included as needed, and the composition content may be adjusted.
- [85] Finally, a graphite sheet 50 is laminated to the top surface of the shielding sheet 20 (S240). Effective heat dissipation is enabled by the graphite sheet 50 having good thermal conductivity, although other sheets having good thermal conductivity other than the graphite sheet 50 may be utilized. Here, the graphite sheet 50 may be formed on the bottom surface of the substrate 10.
- [86] Although not described in detail to avoid redundancy, all of the technical features of the antenna structure 100 according to one embodiment of the present invention described above are applicable to the method of manufacturing the antenna structure.
- [87] It should be noted that the steps S210 through S240 above are described by extracting only representative steps of the antenna structure manufacturing method, and additional steps may be included between each step. For example, further steps may include applying adhesives, attaching a buffer to the bottom surface of the substrate 10, attaching the thermistor 40, attaching a cover film, attaching a top carrier film, and the like to form the detailed configuration included in the individual configuration of the antenna structure 100.

[88] The embodiments of the invention described above are disclosed for illustrative purposes and are not intended to limit the invention, and those having ordinary skill in the art will be able to make various modifications and changes within the spirit and scope of the invention, and such modifications and changes should be viewed as falling within the scope of the invention.

[89] [Description of Numeral Symbols]

[90] 100: Antenna structure

[91] 10: Substrate

[92] 11: Extension

[93] 12: NFC pattern 13: NFC pattern terminals

[94] 14: MST pattern 15: Bends 16: MST pattern terminals

[95] 17: WPC pattern 18: WPC pattern terminals

[96] 20: Shielding sheet

[97] 25: Nanocrystal layer

[98] 30: Attractor

[99] 40: Thermistor 43: Thermistor terminals

[100] 50: Graphite sheet

Claims

- [Claim 1] An antenna structure comprising: a substrate having a predetermined shape; and a shielding sheet laminated on the top surface of the substrate; wherein a WPC pattern is formed on the top or bottom surface of the substrate; and further comprising a thermistor formed on the top or bottom surface of the substrate for measuring the temperature of the WPC pattern.
- [Claim 2] The antenna structure of claim 1, wherein the shielding sheet comprises a nanocrystal layer.
- [Claim 3] The antenna structure of claim 2, wherein the nanocrystal layer has the first to Nth (N is a positive integer) nanoribbons laminated through an adhesive.
- [Claim 4] The antenna structure of claim 1, wherein a buffer is formed on the bottom surface of the substrate to prevent scratches caused by contact with the glass of the terminal on which the antenna structure is mounted.
- [Claim 5] The antenna structure of claim 1, wherein it further comprises an attractor laminated between the substrate and the shielding sheet.
- [Claim 6] The antenna structure of claim 5, wherein at least one or more of an NFC pattern or an MST pattern is further formed on a top surface or a bottom surface of the substrate, and wherein the attractor is laminated to a non-patterned portion of the substrate.
- [Claim 7] The antenna structure of claim 1, wherein the NFC pattern and the MST pattern are further formed spaced apart on a top surface or a bottom surface of the substrate.
- [Claim 8] The antenna structure of claim 7, wherein the NFC pattern, MST pattern, and WPC pattern are formed in order from the outer periphery of the substrate inwards, and wherein inside the WPC pattern, the NFC pattern is spaced apart and extendedly formed.

- [Claim 9] The antenna structure of claim 7, wherein a length of the MST pattern in a lateral direction is less than or equal to a diameter of the WPC pattern.
- [Claim 10] The antenna structure of claim 7, wherein the longitudinal length of the MST pattern is greater than or equal to the diameter of the WPC pattern.
- [Claim 11] The antenna structure of claim 10, wherein the end portion of the MST pattern further comprises a bend that is partially curved along the shape of the WPC pattern.
- [Claim 12] The antenna structure of claim 7, wherein the substrate comprises a predetermined shaped extension formed on one side, wherein the MST pattern is extendedly formed on the extension.
- [Claim 13] The antenna structure of claim 12, wherein the terminals of the NFC pattern, MST pattern, and WPC pattern are exposedly formed on the extension.
- [Claim 14] The antenna structure of claim 1, further comprising: a graphite sheet laminated to a top surface of the shielding sheet or to a bottom surface of the substrate.

[FIG. 1]

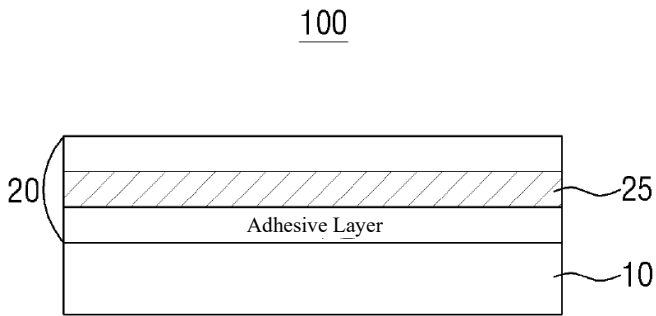

[FIG. 2]

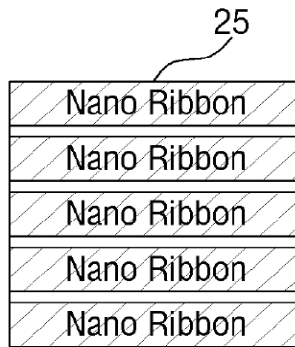

[FIG. 3]

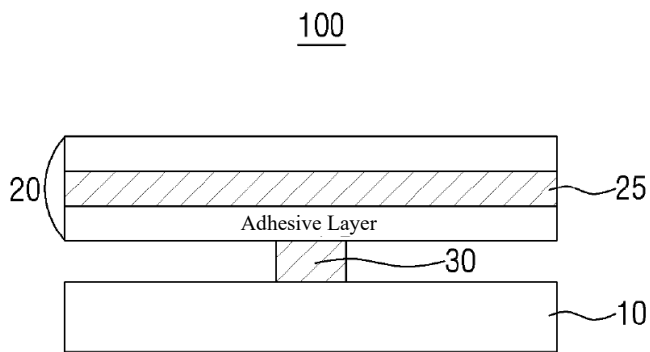

[FIG. 4]

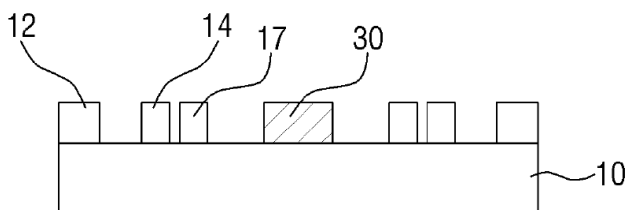

[FIG. 5]

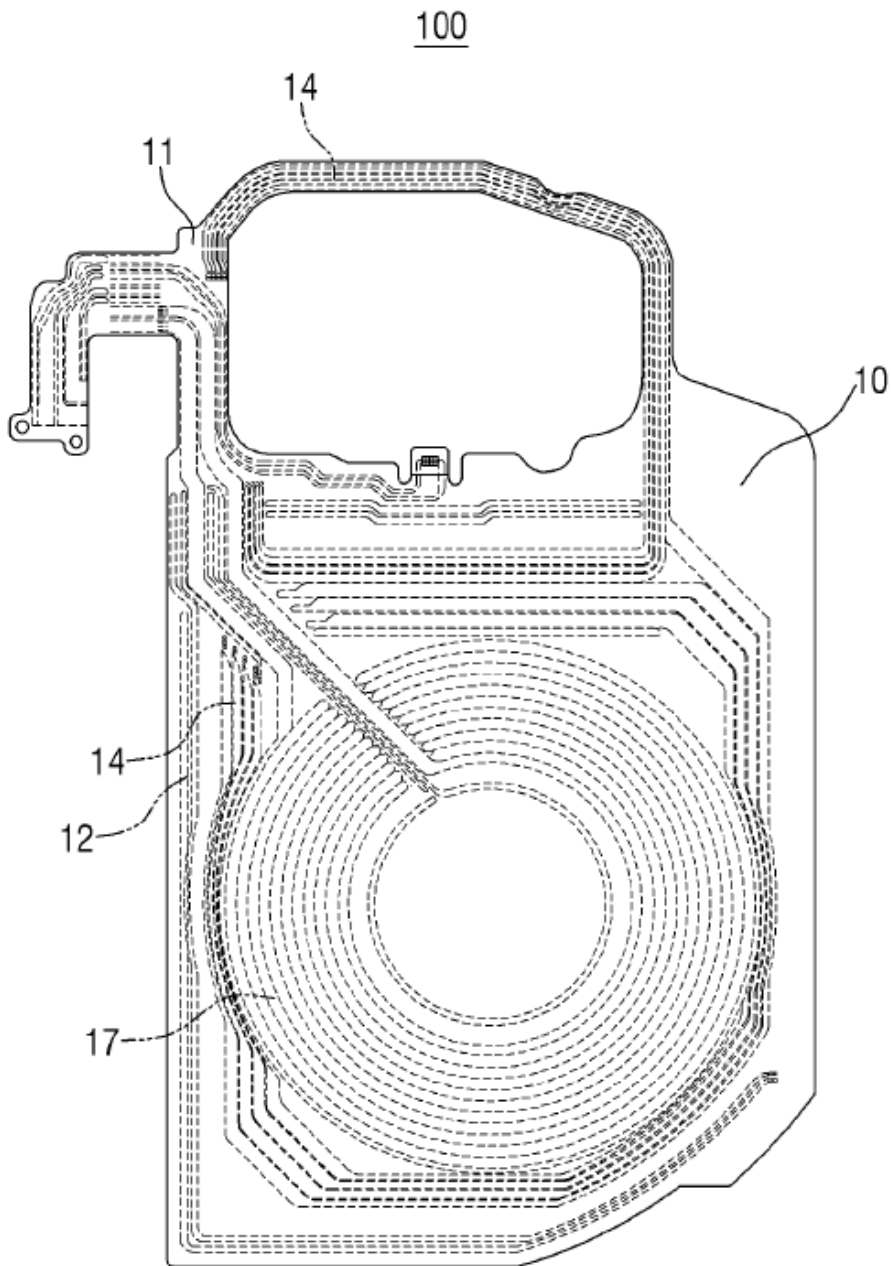

[FIG. 6]

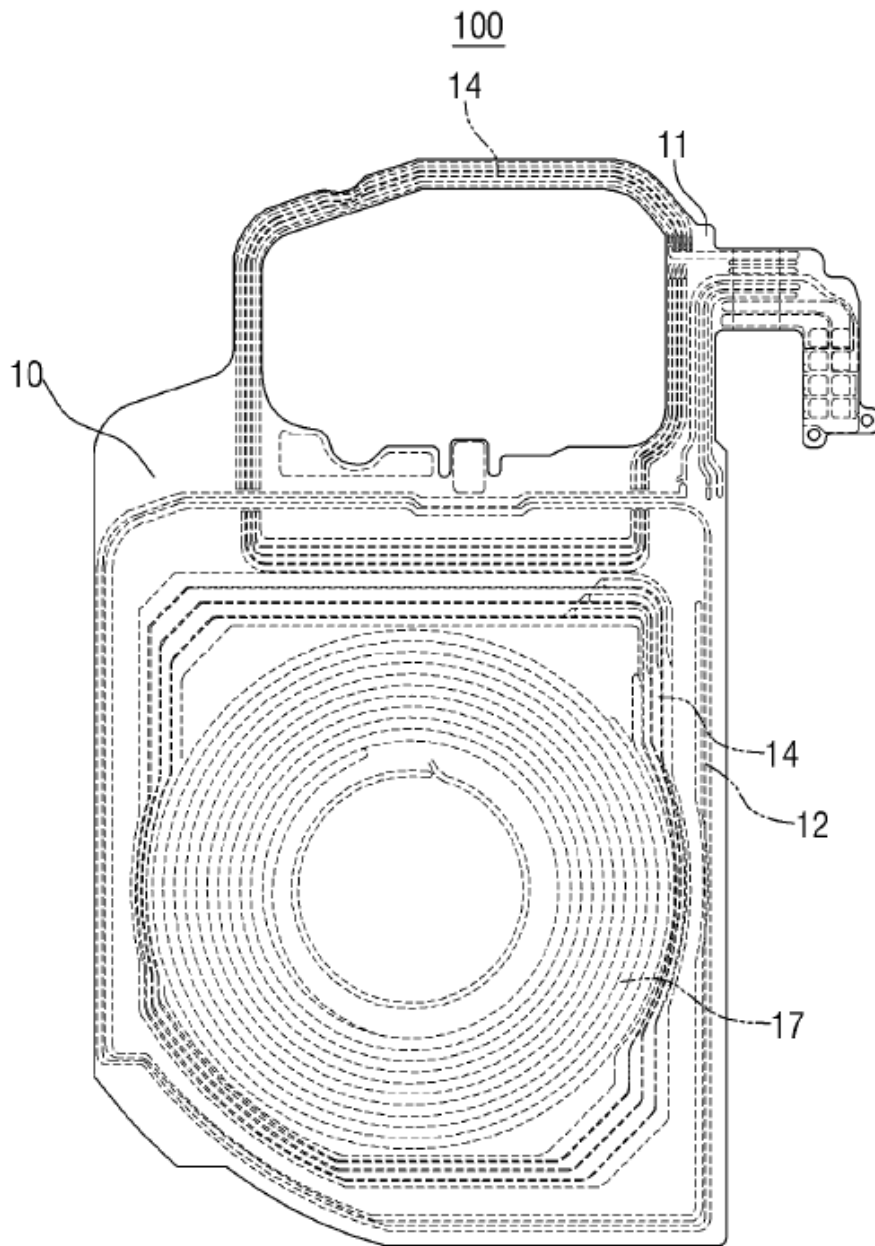

[FIG. 7]

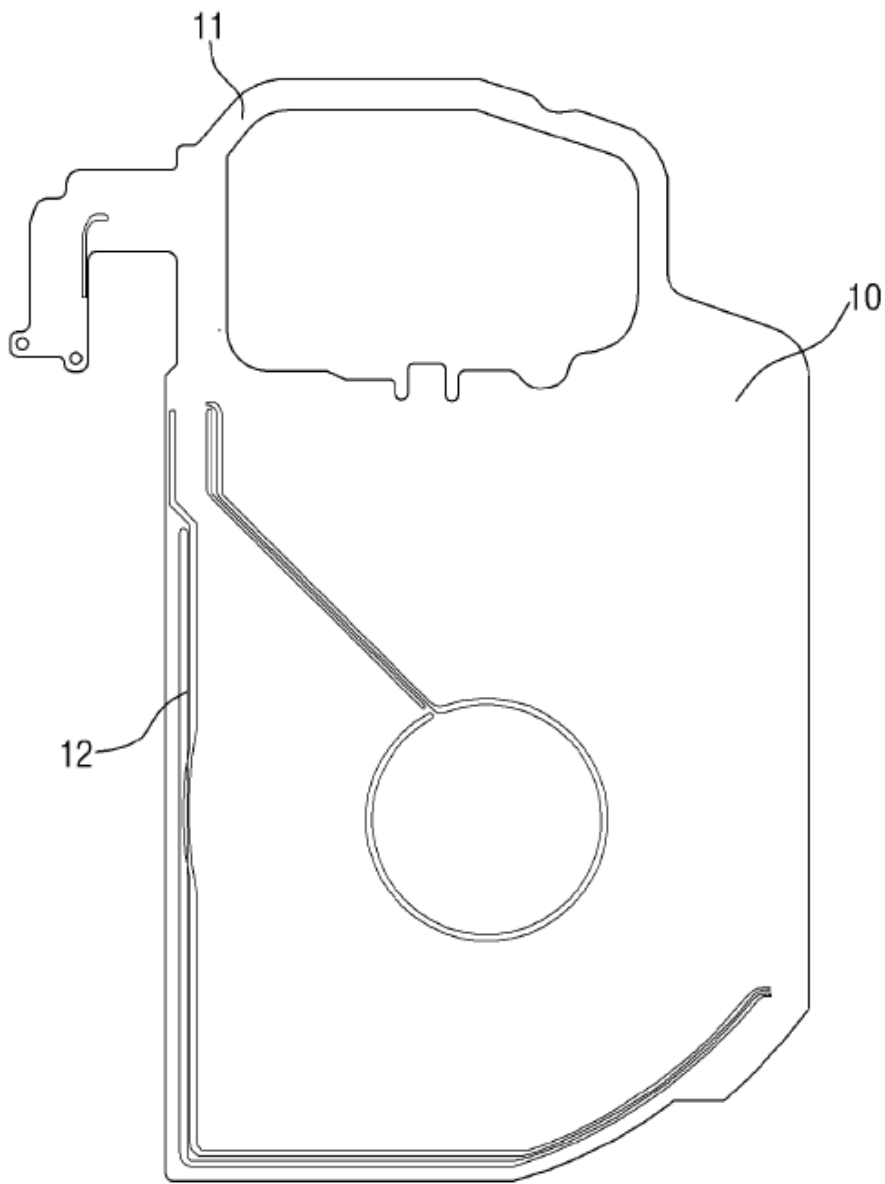

[FIG. 8]

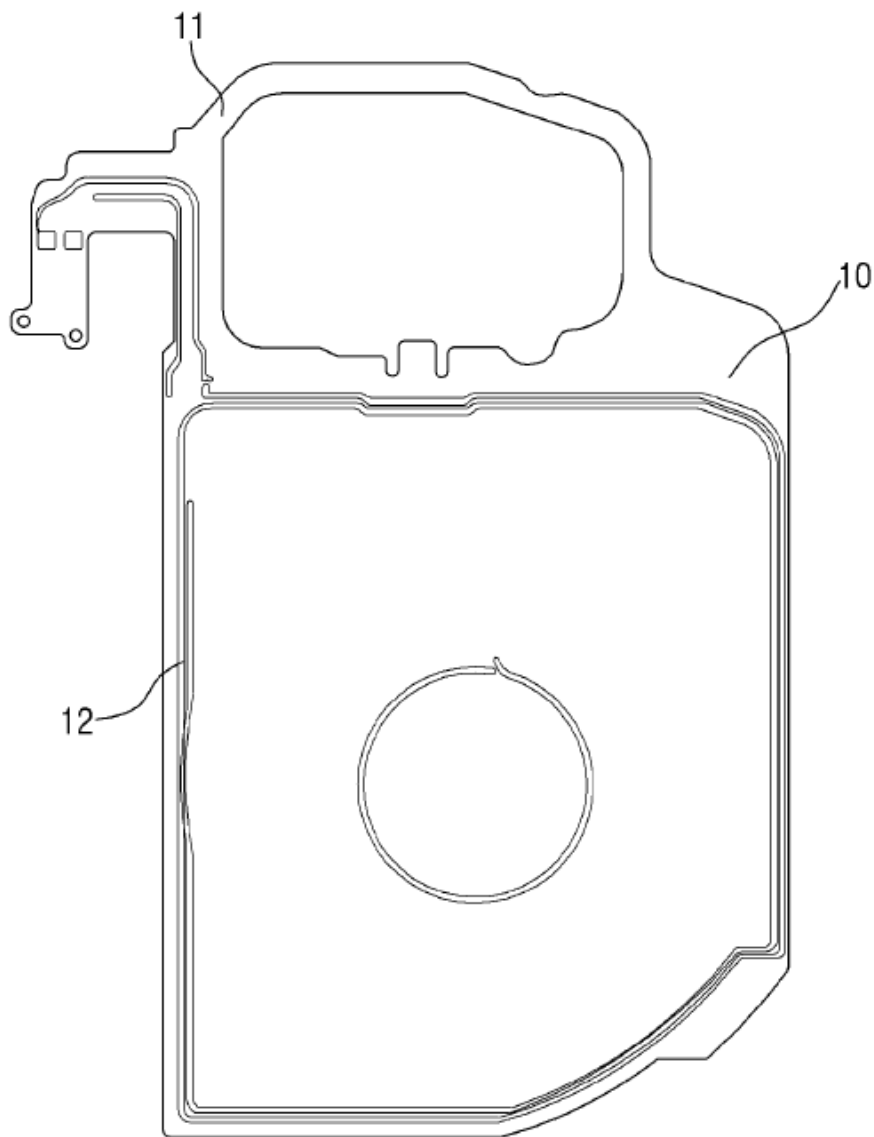

[FIG. 9]

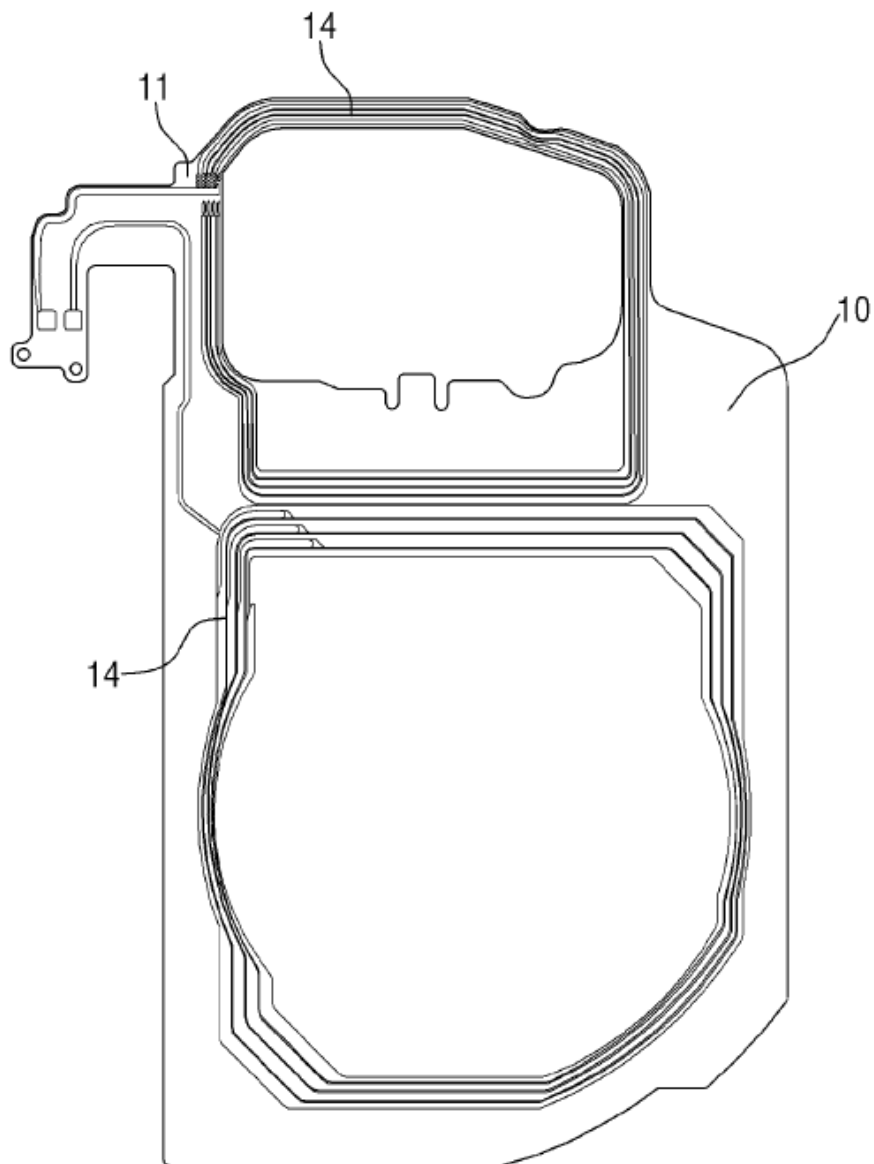

[FIG. 10]

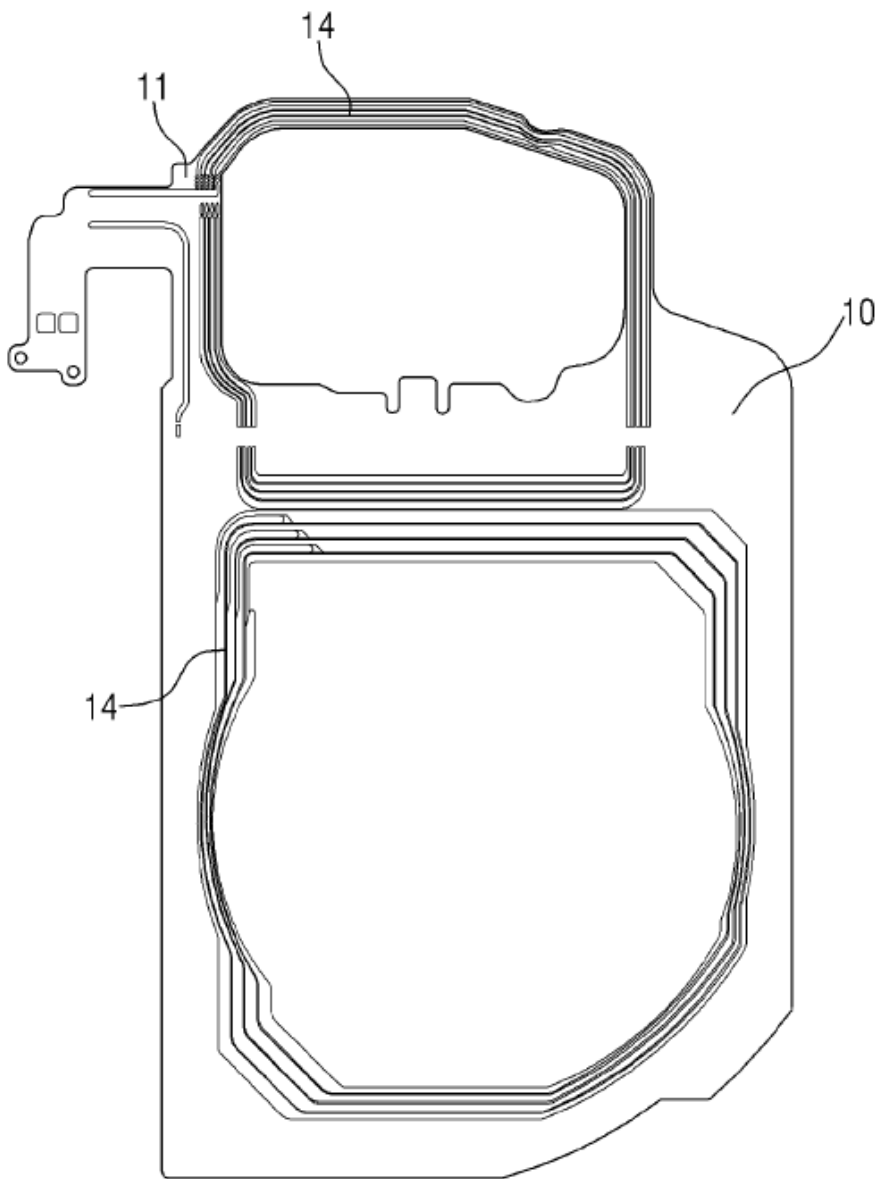

[FIG. 11]

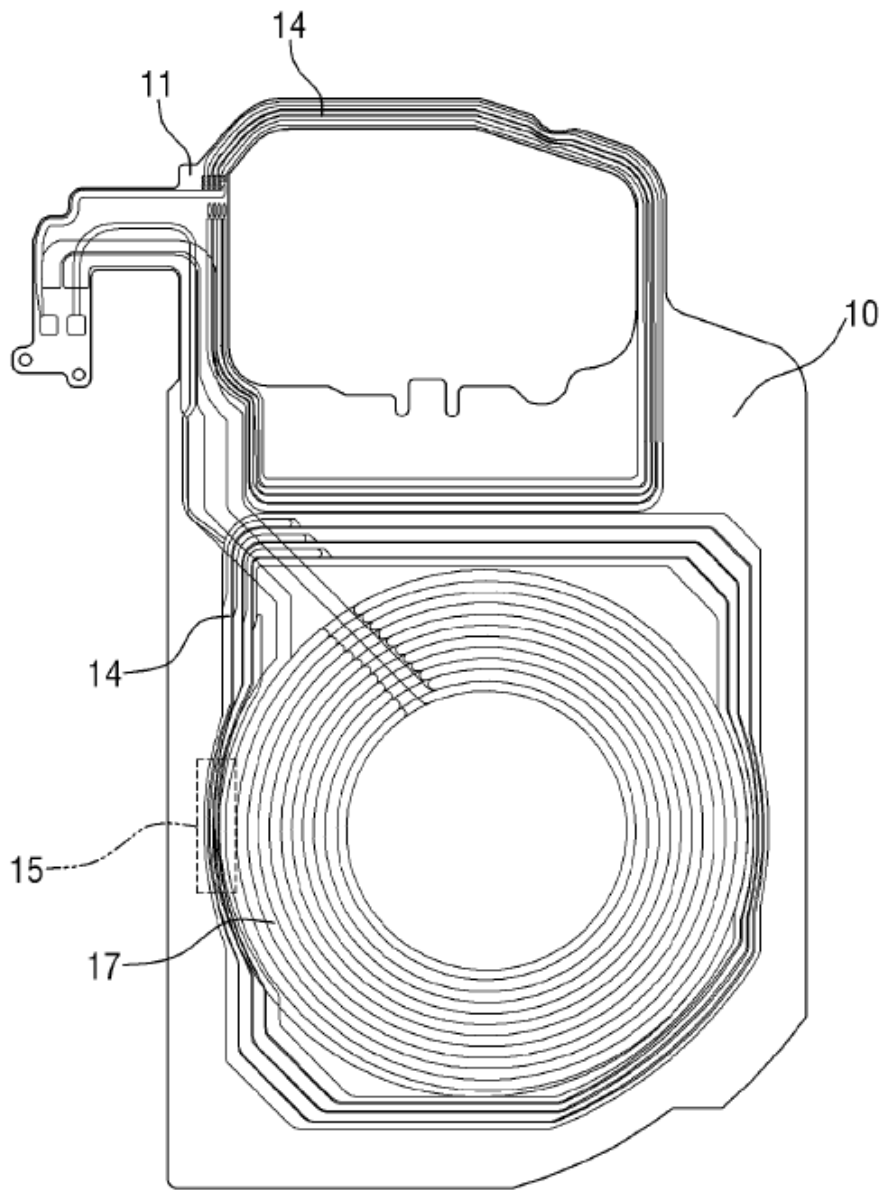

[FIG. 12]

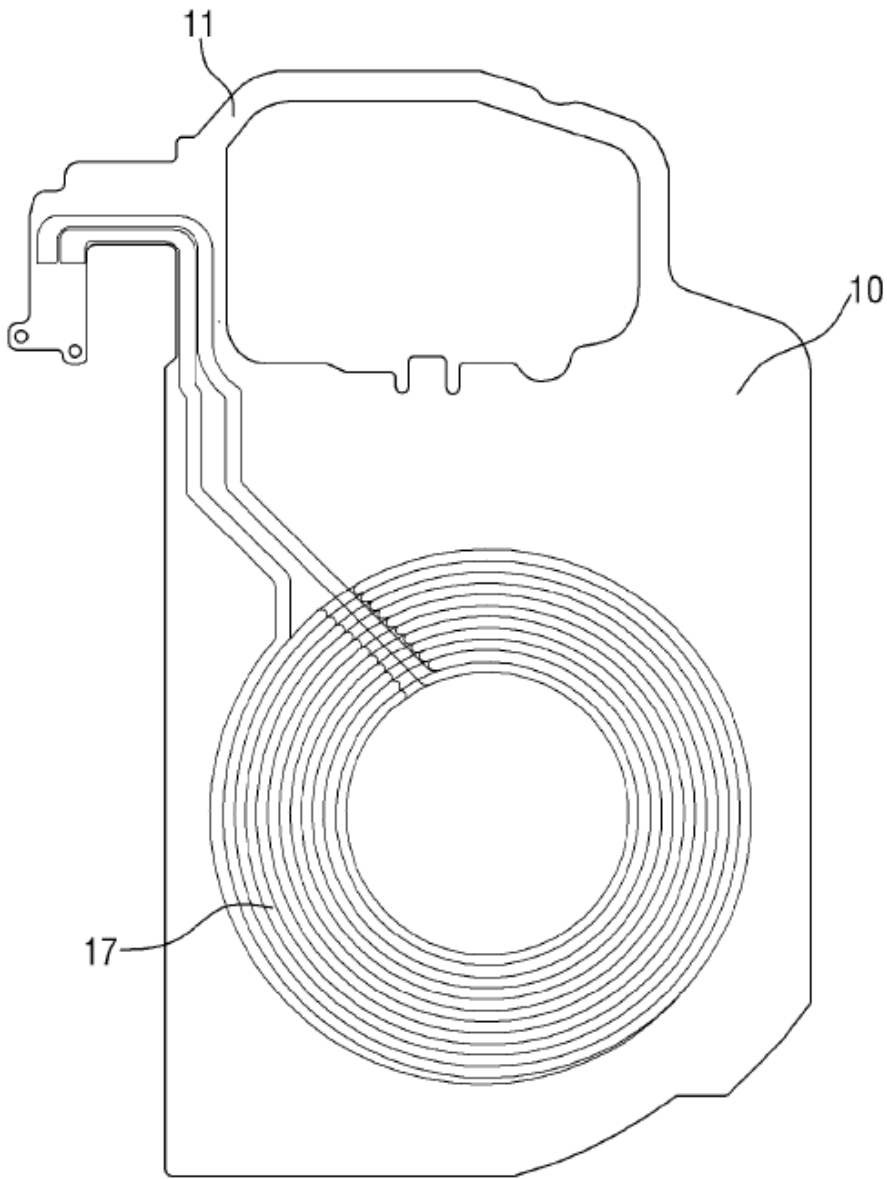

[FIG. 13]

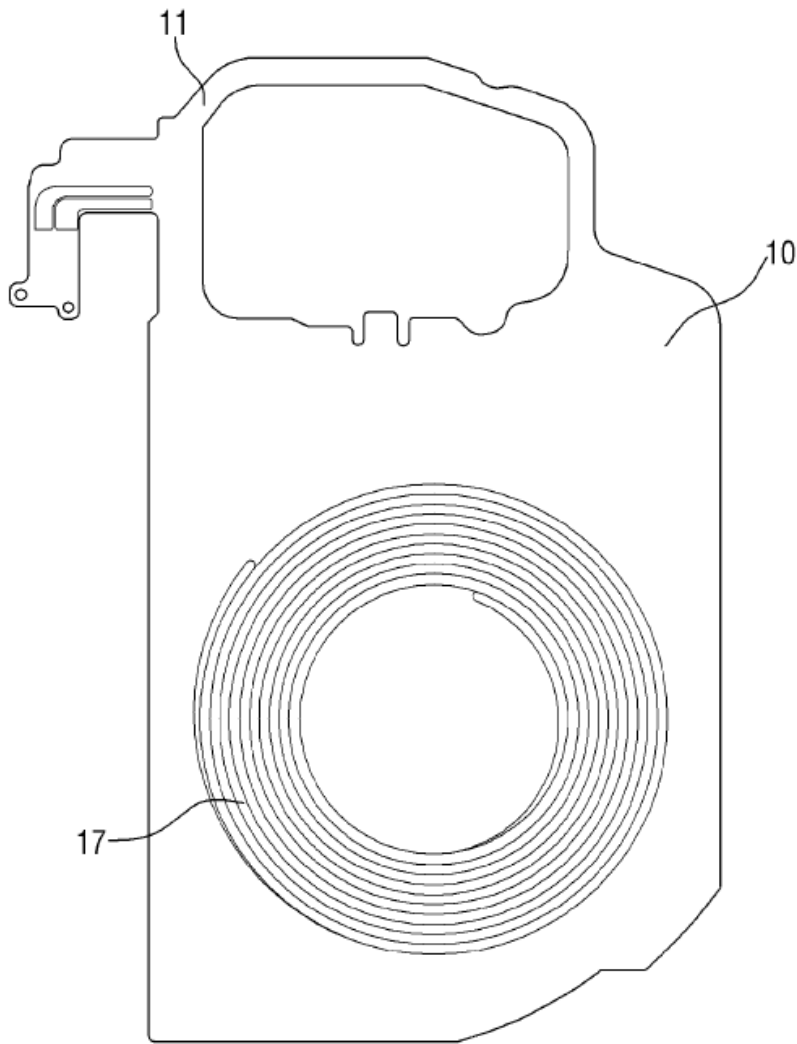

[FIG. 14]

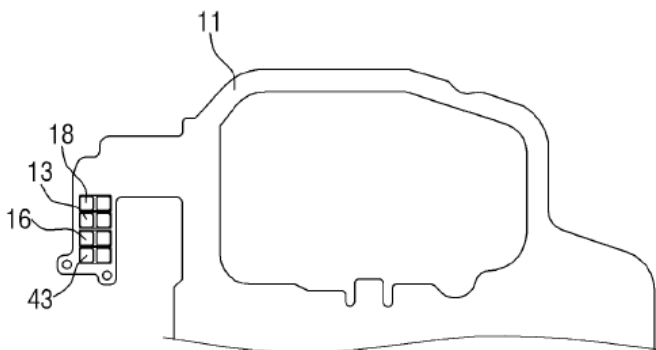

[FIG. 15]

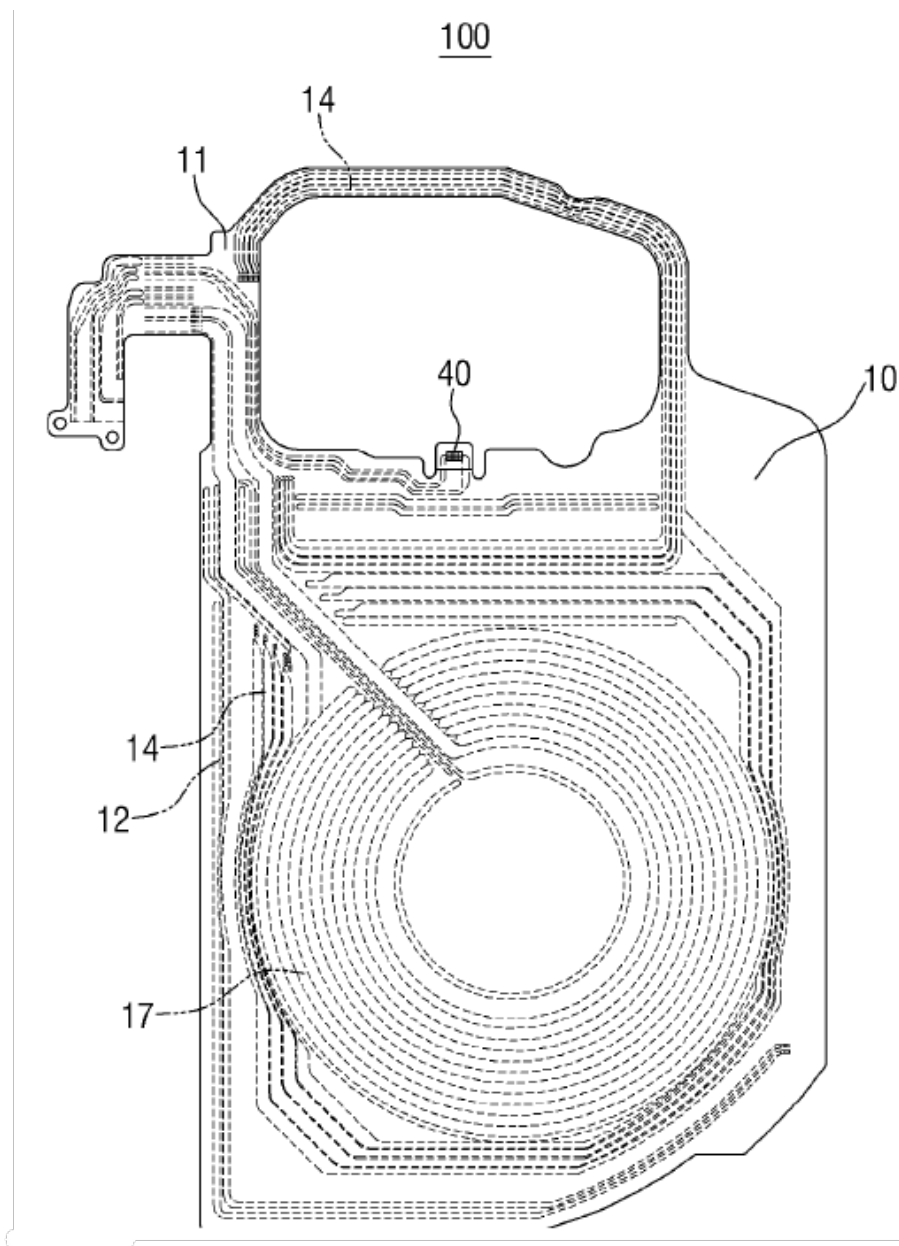

[FIG. 16]

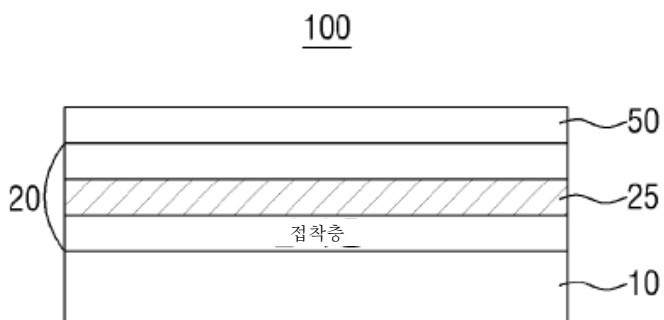

[FIG. 17]

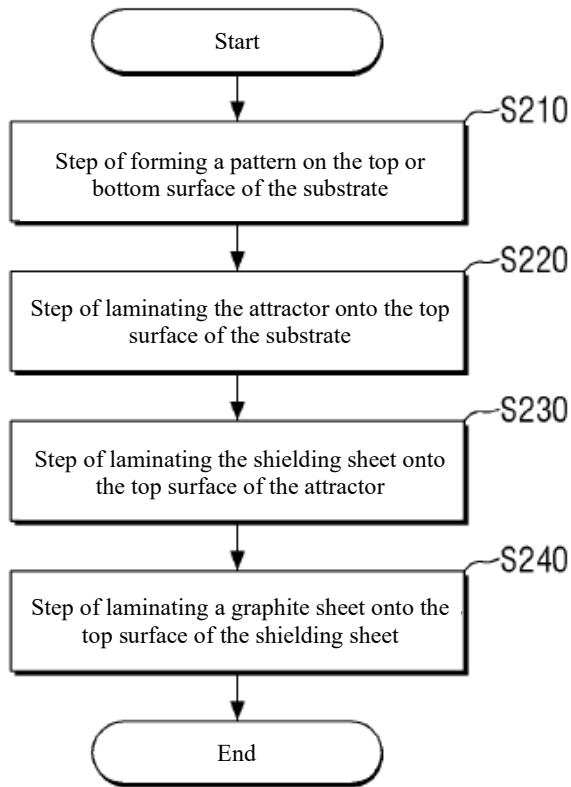

INTERNATIONAL SEARCH REPORT

International application No.

PCT/KR2016/003521

A. CLASSIFICATION OF SUBJECT MATTER <i>H01Q 1/24(2006.01)i, H01Q 1/38(2006.01)i, H01Q 1/52(2006.01)i, H01Q 9/04(2006.01)i, H02J 17/00(2006.01)i, H04B 5/00(2006.01)i</i> According to International Patent Classification (IPC) or to both national classification and IPC		
B. FIELDS SEARCHED Minimum documentation searched (classification system followed by classification symbols) H01Q 1/24; H01Q 7/04; H01F 38/14; H01M 10/46; H02J 17/00; H02J 7/00; H01Q 1/38; H01Q 1/52; H01Q 9/04; H04B 5/00 Documentation searched other than minimum documentation to the extent that such documents are included in the fields searched Korean Utility models and applications for Utility models: IPC as above Japanese Utility models and applications for Utility models: IPC as above Electronic data base consulted during the international search (name of data base and, where practicable, search terms used) eKOMPASS (KIPO internal) & Keywords: wireless charging, antenna, shielding, thermistor, nanocrystal		
C. DOCUMENTS CONSIDERED TO BE RELEVANT		
Category*	Citation of document, with indication, where appropriate, of the relevant passages	Relevant to claim No.
Y	KR 10-2014-0060798 A (SAMSUNG ELECTRO-MECHANICS CO., LTD.) 21 May 2014 See paragraphs [0044], [0063] and claims 1, 4, 7.	1-14
Y	KR 10-2014-0109336 A (AMONSENSE CO., LTD.) 15 September 2014 See abstract and claims 1, 11.	1-14
Y	KR 10-1577425 B1 (AMONSENSE CO., LTD.) 28 December 2015 See paragraph [0048], claim 1 and figure 2.	7-13
A	KR 10-2014-0066415 A (SAMSUNG ELECTRO-MECHANICS CO., LTD.) 02 June 2014 See abstract and claim 6.	1-14
A	KR 10-2014-0091362 A (SNPOWERCOM CO., LTD.) 21 July 2014 See paragraphs [0030]-[0033], claims 1-4 and figure 1.	1-14
<input type="checkbox"/> Further documents are listed in the continuation of Box C. <input checked="" type="checkbox"/> See patent family annex.		
* Special categories of cited documents: "A" document defining the general state of the art which is not considered to be of particular relevance "E" earlier application or patent but published on or after the international filing date "L" document which may throw doubts on priority claim(s) or which is cited to establish the publication date of another citation or other special reason (as specified) "O" document referring to an oral disclosure, use, exhibition or other means "P" document published prior to the international filing date but later than the priority date claimed "I" later document published after the international filing date or priority date and not in conflict with the application but cited to understand the principle or theory underlying the invention "X" document of particular relevance; the claimed invention cannot be considered novel or cannot be considered to involve an inventive step when the document is taken alone "Y" document of particular relevance; the claimed invention cannot be considered to involve an inventive step when the document is combined with one or more other such documents, such combination being obvious to a person skilled in the art "&" document member of the same patent family		
Date of the actual completion of the international search 08 DECEMBER 2016 (08.12.2016)		Date of mailing of the international search report 08 DECEMBER 2016 (08.12.2016)
Name and mailing address of the ISA/KR  Korean Intellectual Property Office Government Complex-Daejeon, 189 Soonsa-ro, Daejeon 302-701, Republic of Korea Facsimile No. +82-42-481-8578		Authorized officer Telephone No.

Form PCT/ISA/210 (second sheet) (January 2015)

INTERNATIONAL SEARCH REPORT
Information on patent family members

International application No.

PCT/KR2016/003521

Patent document cited in search report	Publication date	Patent family member	Publication date
KR 10-2014-0060798 A	21/05/2014	NONE	
KR 10-2014-0109336 A	15/09/2014	CN 105027355 A KR 10-2015-0045421 A KR 10-2015-0050541 A KR 10-2015-0142653 A US 2016-0064814 A1 WO 2014-137151 A1	04/11/2015 28/04/2015 08/05/2015 22/12/2015 03/03/2016 12/09/2014
KR 10-1577425 B1	28/12/2015	KR 10-1574214 B1 KR 10-1627844 B1	04/12/2015 07/06/2016
KR 10-2014-0066415 A	02/06/2014	CN 103840513 A KR 10-1558107 B1 US 2014-0145674 A1 US 9385547 B2	04/06/2014 07/10/2015 29/05/2014 05/07/2016
KR 10-2014-0091362 A	21/07/2014	NONE	

INTERNATIONAL SEARCH REPORT

A. CLASSIFICATION OF TECHNICAL SUBJECT MATTER OF THE INVENTION (International Patent Classification (IPC))
H01Q 1/24(2006.01)i, H01Q 1/38(2006.01)i, H01Q 1/52(2006.01)i, H01Q 9/04(2006.01)i, H02J 17/00(2006.01)i, H04B 5/00(2006.01)i

B. FIELDS SEARCHED

Minimum documentation searched (international patent classification system and classification no. marked)

H01Q 1/24; H01Q 7/04; H01F 38/14; H01M 10/46; H02J 17/00; H02J 7/00; H01Q 1/38; H01Q 1/52; H01Q 9/04; H04B 5/00

Documentation searched other than minimum documentation to the extent that such documents are included in the fields searched
 Korean utility models and Korean utility model applications: IPC indicated in "Minimum documentation searched" above
 Japanese utility models and Japanese utility model applications: IPC indicated in "Minimum documentation searched" above

Electronic database consulted during the international search (name of database, and search terms used (if applicable))

eKOMPASS (KIPO internal search system) & Keywords: wireless charging, antenna, shielding, thermistor, nanocrystal

C. DOCUMENTS CONSIDERED TO BE RELEVANT

Category *	Citation of document, with indication, where appropriate, of the relevant passages	Relevant to claim No.
Y	KR 10-2014-0060798 A (SAMSUNG ELECTRO-MECHANICS CO, LTD.) May 21, 2014 See paragraphs [0044], [0063] and claims 1.4, 7.	1-14
Y	KR 10-2014-0109336 A (AMONSENSE CO., LTD.) Sept. 15, 2014 See abstract and claims 1, 11.	1-14
Y	KR 10-1577425 B1 (AMONSENSE CO., LTD.) Dec. 28, 2015 See paragraph [0048], claim 1 and FIG. 2.	7-13
A	KR 10-2014-0066415 A (SAMSUNG ELECTRO-MECHANICS CO., LTD.) Jun. 2, 2014 See abstract and claim 6.	1-14
A	KR 10-2014-0()91362 A (SNPOWERCOM CO., LTD.) July 21, 2014 See paragraphs [0030]-[0033], claims 1-4 and FIG. 1.	1-14

Further documents are listed in the continuation of Box C.

See patent family annex.

*. Special categories of cited documents:

"A" document defining the general state of the art which is not considered to be of particular relevance

"E" earlier application or patent that published on or after the international filing date

"L" document which may throw doubts on priority claim(s) or which is cited to establish the publication date of another citation or other special reason (as specified)

"O" document referring to an oral disclosure, use, exhibition or other means

"P" document published prior to the international filing date but later than the priority date claimed

"T" later document published after the international filing date or priority date and not in conflict with the application but cited to understand the principle or theory underlying the invention

"X" document of particular relevance; the claimed invention cannot be considered novel or cannot be considered to involve an inventive step when the document is taken alone

"Y" document of particular relevance; the claimed invention cannot be considered to involve an inventive step when the document is combined with one or more other such documents, such combination being conspicuous to a person skilled in the art

"&" document member of the same patent family

Date of the actual completion of the international search

Dec. 8, 2016 (12/08/2016)

Date of mailing of the international search report

Dec. 8, 2016 (12/08/2016)

ISA/KR name and zip code



Korean Intellectual Property Office
 (Daejeon Government Complex Bldg. #4) 189,
 Cheongsa-ro, Seo-gu, Daejeon, (zip) 35208, Korea

Fax: +82-42-481-8578

Examiner

Eun Kyu Lee

[seal affixed: Eun Kyu Lee]

Tel: +82-42-481-8264



INTERNATIONAL SEARCH REPORT
Information on patent family members

International application No.

PCT/KR2016/003521

Patent document cited in search report	Appl. Publication date [DD/MM/YYYY]	Patent family member	Publication date [DD/MM/YYYY]
KR 10-2014-0060798 A	21/05/2014	NONE	
KR 10-2014-0109336 A	15/09/2014	CN 105027355 A KR 10-2015-0045421 A KR 10-2015-0050541 A KR 10-2015-0142653 A US 2016-0064814 A1 WO 2014-137151 A1	04/11/2015 28/04/2015 08/05/2015 22/12/2015 03/03/2016 12/09/2014
KR 10-1577425 B1	28/12/2015	KR 10-1574214 B1 KR 10-1627844 B1	04/12/2015 07/06/2016
KR 10-2014-0066415 A	10/23/2014	CN 103840513 A KR 10-1558107 B1 US 2014-0145674 A1 US 9385547 B2	04/06/2014 07/10/2015 29/05/2014 05/07/2016
KR 10-2014-0091362 A	21/07/2014	NONE	