

Petition for *Inter Partes* Review of U.S. Patent No. 11,303,011

UNITED STATES PATENT AND TRADEMARK OFFICE

---

**BEFORE THE PATENT TRIAL AND APPEAL BOARD**

---

SAMSUNG ELECTRONICS CO., LTD. AND SAMSUNG ELECTRONICS  
AMERICA, INC.,  
Petitioners,

v.

AQ CORPORATION,  
Patent Owner.

---

Case No. IPR2026-\_\_\_\_\_

**U.S. PATENT NO. 11,303,011**

---

**PETITION FOR *INTER PARTES* REVIEW**

**TABLE OF CONTENTS**

<b>I.</b>	<b>INTRODUCTION .....</b>	<b>1</b>
<b>II.</b>	<b>STANDING (§42.104(a)).....</b>	<b>4</b>
<b>III.</b>	<b>RELIEF REQUESTED (§42.104(b)) .....</b>	<b>4</b>
<b>IV.</b>	<b>'011 PATENT OVERVIEW .....</b>	<b>5</b>
	A. Specification .....	5
	B. Prosecution History .....	6
<b>V.</b>	<b>PRIOR ART OVERVIEW .....</b>	<b>6</b>
	A. Seong .....	6
	B. 005Lee .....	8
	C. Kang .....	10
	D. Cho .....	12
	E. Ahn .....	14
	F. 721Lee .....	16
<b>VI.</b>	<b>LEVEL OF ORDINARY SKILL IN THE ART .....</b>	<b>19</b>
<b>VII.</b>	<b>CLAIM CONSTRUCTION.....</b>	<b>19</b>
<b>VIII.</b>	<b>THE CHALLENGED CLAIMS ARE UNPATENTABLE.....</b>	<b>20</b>
	A. Ground 1: Seong Renders Claims 1-6 Obvious In View Of Kang And Cho .....	20
	1. Motivation To Combine Seong, Kang, And Cho .....	20
	2. [1] .....	24
	3. [2] .....	59
	4. [3] .....	60

5.	[4]	61
6.	[5]	62
7.	[6]	63
B.	Ground 2: Ahn Renders Claims 1–6 Obvious In View Of 721Lee	65
1.	Motivation To Combine Ahn And 721Lee	65
2.	[1]	68
3.	[2]	97
4.	[3]	98
5.	[4]	100
6.	[5]	101
7.	[6]	102
C.	Ground 3: 005Lee Renders Claims 1-6 Obvious in view of Seong and Cho	103
1.	Motivation To Combine 005Lee, Seong, and Cho	103
2.	[1]	109
3.	[2]	132
4.	[3]	133
5.	[4]	134
6.	[5]	135
7.	[6]	136
<b>IX.</b>	<b>SECONDARY CONSIDERATIONS</b>	<b>138</b>
<b>X.</b>	<b>MANDATORY NOTICES UNDER 37 C.F.R. §42.8</b>	<b>138</b>
A.	Real Parties-in-Interest	138

Petition for *Inter Partes* Review of U.S. Patent No. 11,303,011

B.	Related Matters.....	138
C.	Lead and Backup Counsel, Service, and Power of Attorney .....	139
<b>XI.</b>	<b>PAYMENT OF FEES UNDER 37 C.F.R. §42.103.....</b>	<b>139</b>

**TABLE OF AUTHORITIES**

<b>Cases</b>	<b>Page(s)</b>
<i>AQ Corporation v. Samsung Electronics Co., Ltd. et al.</i> , Case No. 2:25-cv-01012-JRG (EDTX) .....	138
<b>Other Authorities</b>	
37 C.F.R. §42.8 .....	138
37 C.F.R. §42.10(b) .....	139
37 C.F.R. §42.100(b) .....	19
37 C.F.R. §42.103 .....	139

**LIST OF EXHIBITS**

<b>Exhibit No.</b>	<b>Description</b>
1001	U.S. Patent No. 11,303,011 (“’011 Patent”)
1002	Declaration of David K. Choi, Ph.D
1003	<i>Curriculum Vitae</i> of David K. Choi, Ph.D
1004	Excerpted File History of U.S. 11,303,011 (App. No. 17/105,012)
1005	PCT Publication 2017/175886 (“SeongPCT”)
1006	Certified English Translation of PCT Publication 2017/175886 (“Seong”)
1007	U.S. Pat. App. Pub. No. 2019/0109373 (“Ahn”)
1008	U.S. Patent No. 10,269,005 (“005Lee”)
1009	Korean Patent Publication 10-2017-0093670 (“ChoKPP”)
1010	Certified English Translation of Korean Patent Publication 10-2017-0093670 (“Cho”)
1011	U.S. Pat. App. Pub. No. 2017/0228721 (“721Lee”)
1012	U.S. Pat. App. Pub. 2018/0198209 (“Kang”)
1013	Comparison of the specifications of U.S. Patent No. 11,303,011 (“’011 Patent”) and U.S. Pat. App. Pub. 2018/0198209 (“Kang”)
1014	U.S. Pat. App. Pub. No. 2010/0090824 (“Rowell”)
1015	Exhibit A to Patent Owner’s Disclosure of Asserted Claims and Infringement Contentions in <i>AQ Corporation v. Samsung Electronics Co., Ltd. et al.</i> , Case No. 2:25-cv-01012-JRG (EDTX)
1016	William H. Hayt, Jr. and Jack E. Kemmerly, <i>Engineering Circuit Analysis</i> (1993)

Petition for *Inter Partes* Review of U.S. Patent No. 11,303,011

1017	Mohamed M. El Rayes, et al., “A Review on Wireless Power Transfer,” IJETT Vol. 40. No. 5 (2016)
1018	Sung-Gu Kang, et al., “Near-Field Communication in Biomedical Applications,” Sensors (2021)
1019	Zebra, RFID Inlay Placement/Power Guidelines (2014)
1020	Constantine A. Balanis, “The Evolution of Antenna Technology,” IEEE Antenna & Propagation Magazine (2024)
1021	G. Stojanovic and Lj. Zivanov, “Comparison of Optimal Design of Different Spiral Inductors,” MIEL Vol. 2 (2004)
1022	Chandrasekharan Nataraj, et al., “General Analysis of Resonance Coupled Wireless Power Transfer (WPT) Using Inductive Coils,” Technical Gazette 25, 3 (2018).
1023	Zachariah Peterson, “How to Design a Printed Circuit Board in 10 Easy Steps,” (2025), <a href="https://resources.altium.com/p/10-easy-steps-comprehensively-designing-circuit-board-altium-designer">https://resources.altium.com/p/10-easy-steps-comprehensively-designing-circuit-board-altium-designer</a>
1024	“The Discovery of Radio Waves – 1888,” Spark Museum, <a href="http://www.sparkmuseum.com/BOOK_HERTZ.HTM">http://www.sparkmuseum.com/BOOK_HERTZ.HTM</a>
1025	“How Do Checkpoint Labels and Hard Tags work?,” Loss Prevention Systems, <a href="https://www.losspreventionsystems.com/checkpoint-labels-hard-tags-work/">https://www.losspreventionsystems.com/checkpoint-labels-hard-tags-work/</a>
1026	“Qi: Mobile Charging Empowered,” Wireless Power Consortium, <a href="https://www.wirelesspowerconsortium.com/standards/qi-wireless-charging/">https://www.wirelesspowerconsortium.com/standards/qi-wireless-charging/</a>
1027	“Wireless Charging,” NFC Forum, <a href="https://nfc-forum.org/build/specifications/wireless-charging/">https://nfc-forum.org/build/specifications/wireless-charging/</a>
1028	“Qi Wireless Charging,” Lenhardt, <a href="https://ib-lenhardt.com/kb/qi-wireless-charging">https://ib-lenhardt.com/kb/qi-wireless-charging</a>
1029	U.S. Patent No. 649,621
1030	U.S. Patent No. 1,119,732

Petition for *Inter Partes* Review of U.S. Patent No. 11,303,011

1031	U.S. Patent No. 4,937,585
1032	Chinese Patent No. CN209266128
1033	Korean Patent No. KR20180113064
1034	PCT WO 2019/070090
1035	Korean Patent No. KR101832344
1036	U.S. Patent No. 4,313,152
1037	U.S. Patent No. 1,563,731
1038	Performance Specification: MIL-PRF-55110F (1993)

**LIST OF CHALLENGED CLAIMS<sup>1</sup>**

Reference Number	Claim Limitation
<b>Claim 1</b>	
[1pre]	A smartphone antenna module comprising:
[1a]	a substrate having a first major surface and a second major surface facing away from the first major surface;
[1b]	the first major surface comprising a first central portion, a first inner ring portion surrounding the first central portion, and a first outer ring portion surrounding the first inner ring portion;
[1c]	the second major surface comprising a second central portion overlapping the first central portion, a second inner ring portion surrounding the second central portion and overlapping the first inner ring portion, and a second outer ring portion surrounding the second inner ring portion and overlapping the first outer ring portion;
[1d]	a first antenna pattern formed on the first major surface and comprising an inner coil formed on the first inner ring portion and an outer coil on the first outer ring portion;
[1e]	a second antenna pattern formed on the second major surface and comprising an NFC antenna pattern formed on the second central portion, an inner antenna pattern formed on the second inner ring portion, [and] an outer antenna pattern formed on the second [outer] ring portion;
[1f]	the inner antenna pattern comprising a plurality of concentric C-shaped lines forming a radially-extending inner gap on the second inner ring portion;
[1g]	the outer antenna pattern comprising a plurality of concentric C-shaped lines forming a radially-extending outer gap on the second outer ring portion;
[1h]	wherein the radially-extending outer gap on the second outer ring portion and the radially-extending inner gap on the second inner ring portion are connected and aligned in a radial direction;

---

<sup>1</sup> Brackets reflect corrections made in Certificates of Correction dated August 30, 2022, June 20, 2023, and May 13, 2025. Ex1004, 1084–108.

Reference Number	Claim Limitation
[1i]	two NFC antenna extension lines formed on the second major surface, in which the two NFC antenna extension lines extend along the radial direction through both the radially-extending inner gap and the radially-extending outer gap;
[1j]	an inner extension line formed on the second major surface, in which the inner extension line extends along the radial direction through both the radially-extending inner gap and the radially-extending outer gap;
[1k]	an outer extension line formed on the second major surface, in which the outer extension [line] connects to the outer antenna pattern and extends along the radial direction through the radially-extending outer gap;
[1l]	wherein the two NFC antenna extension lines, the inner extension line, and the outer extension line[]are extending substantially in parallel;
[1m]	wherein each of the two NFC antenna extension lines, the inner extension line, and the outer extension line[]formed on the second major surface overlaps the outer coil formed on the first outer ring portion of the first major surface;
[1n]	wherein the inner coil and the outer coil are electrically connected in parallel.
<b>Claim 2</b>	
[2]	The smartphone antenna module of claim 1, wherein the first antenna pattern and the second antenna pattern are electrically connected [with] each other through a plurality of vias.
<b>Claim 3</b>	
[3]	The smartphone antenna module of claim 1, wherein the inner extension line is referred to as a first inner extension line, wherein the smartphone antenna module further comprises a second inner extension line formed on the second major surface, in which the second inner extension [line] connects to the inner antenna pattern and extends along the radial direction through the radially-extending outer gap.
<b>Claim 4</b>	
[4]	The smartphone antenna module of claim 1, wherein the inner coil includes a wire line having a width different from that of a wire line of the outer coil.

Petition for *Inter Partes* Review of U.S. Patent No. 11,303,011

<b>Reference Number</b>	<b>Claim Limitation</b>
<b>Claim 5</b>	
[5]	The smartphone antenna module of claim 1, wherein the inner coil has a first number of turns that is greater than that of[] the outer coil.
<b>Claim 6</b>	
[6]	A smartphone comprising: a battery; and the smartphone antenna module of claim 1, wherein the inner coil and the outer coil are configured for wireless battery charging.

## I. INTRODUCTION

The '011 Patent “relates to a smartphone antenna module.” Ex1001, 1:16-18.

The patent specification contends that space is limited for antennas, which the alleged invention purports to address by arranging “coil antenna patterns” in rings on both sides of a PCB and “electrically connect[ing]” them through vias:

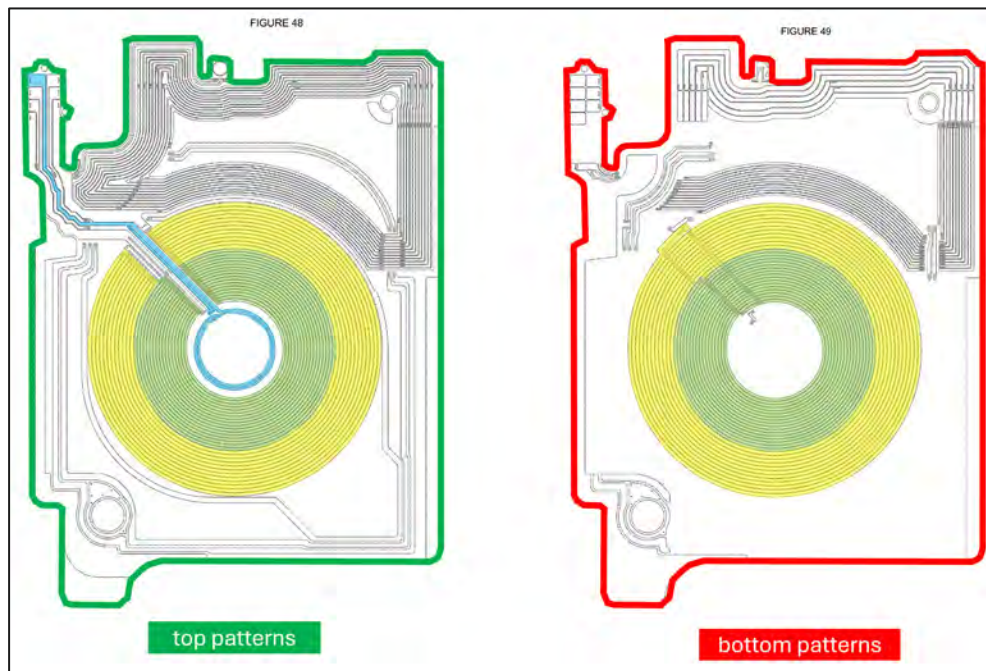

Ex1001, 1:22-41, 41:50-42:4, Figs. 48-49; Ex1002 ¶54.<sup>2</sup>

But forming wireless-communication antennas—including NFC (Near Field Communication), MST (Magnetic Secure Transmission), and WPC (Wireless Power Charging)—on both sides of a substrate was well-known, as were the generic components and layouts that the '011 Patent claims. Seong, Ahn, and 005Lee taught

---

<sup>2</sup> All annotations and emphasis added.

essentially identical layouts addressing the same space-efficiency problem years earlier:

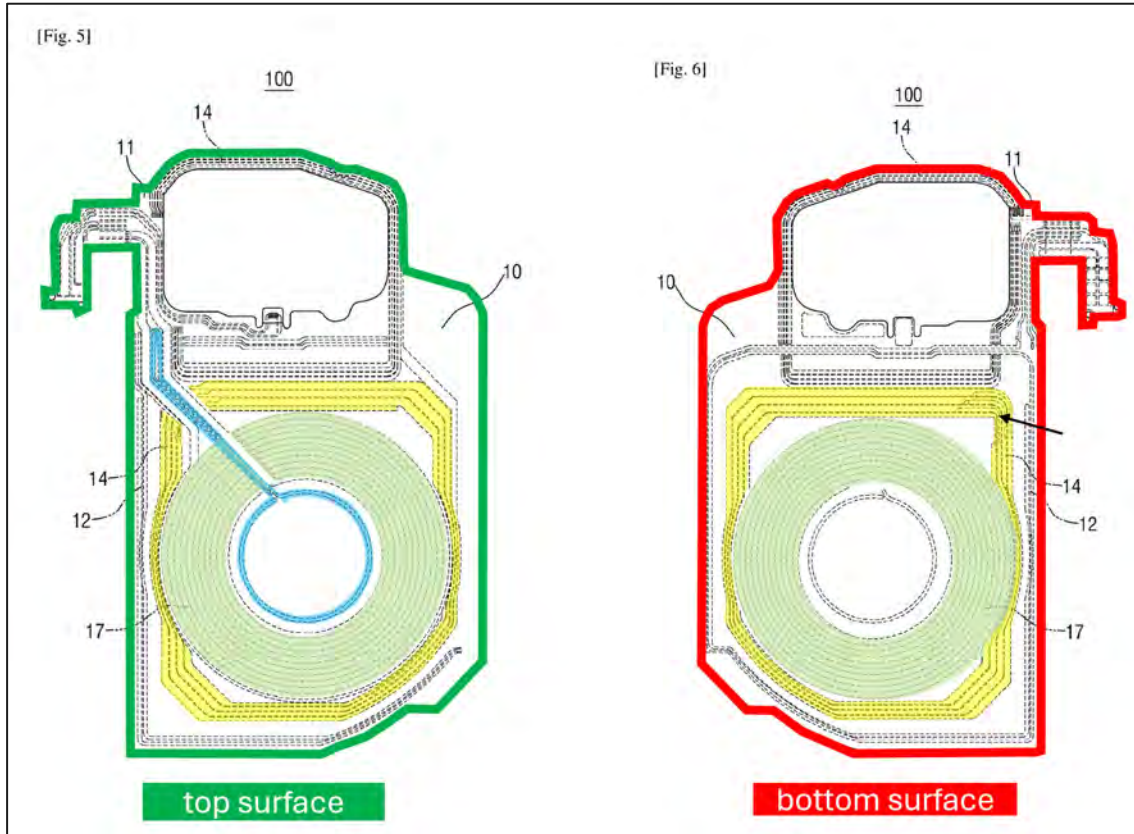

Ex1006, Figs. 5-6; Ex1002 ¶56.

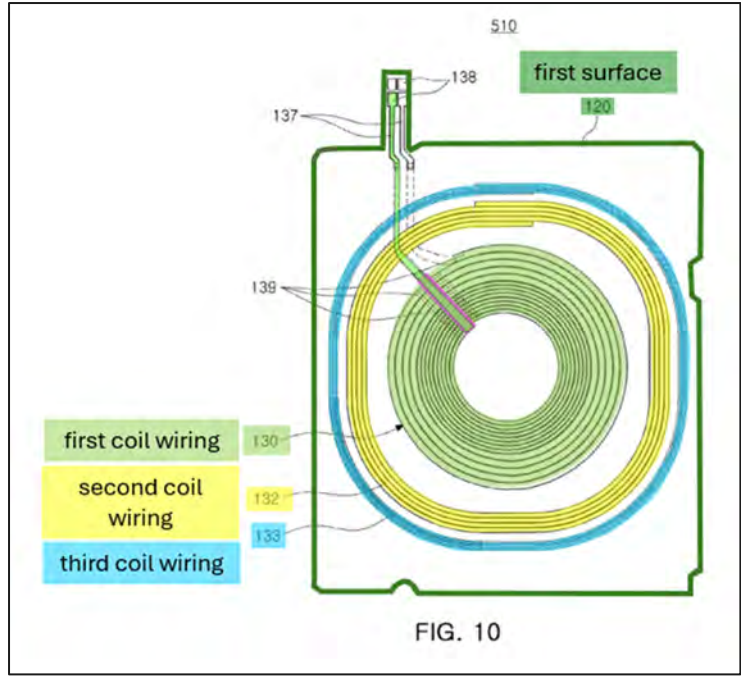

Ex1007, Fig. 10; Ex1002 ¶57.

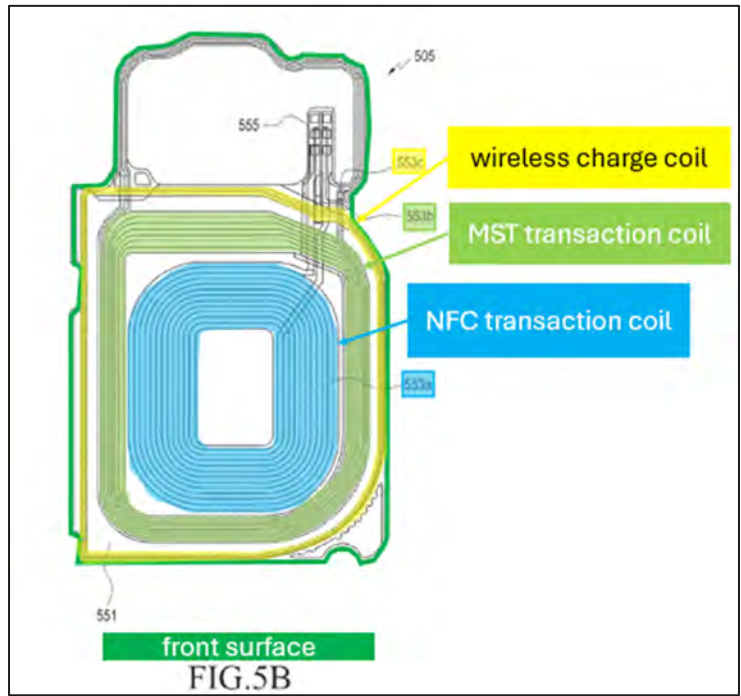

Ex1008, Fig. 5B; Ex1002 ¶58.

**II. STANDING (§42.104(A))**

Petitioners certify that the '011 Patent is available for IPR, and that Petitioners are not barred or estopped from requesting IPR to challenge the claims on the grounds herein.

**III. RELIEF REQUESTED (§42.104(B))**

Petitioners respectfully request review and cancellation under §311 of claims 1-6 as follows.<sup>3</sup> This table identifies the prior art status of the references relied on herein:

<b>Prior Art</b>	<b>Publication</b>	<b>Basis</b>
PCT Publication 2017/175886 ("Seong")	10/12/2017	AIA 102(a)(1), 102(a)(2)
U.S. Patent Application Publication 2019/0109373 ("Ahn")	4/11/2019	
U.S. Patent 10,269,005 ("005Lee")	7/21/2016	
Korean Patent Publication 10- 2017-0093670 ("Cho")	8/16/2017	

---

<sup>3</sup> Petitioners do not concede that any claims satisfy other requirements for patentability that cannot be raised in IPR, including §§101 and 112.

Prior Art	Publication	Basis
U.S. Patent Application Publication 2017/0228721 (“721Lee”)	8/10/2017	
U.S. Patent Application Publication 2018/0198209 (“Kang”)	7/12/2018	AIA 102(a)(1)

This table identifies the invalidity grounds relied on herein:

Ground	Claims	Basis
1	1-6	§103: Seong, Kang, Cho
2	1-6	§103: Ahn, 721Lee
3	1-6	§103: 005Lee, Seong, Ahn

#### IV. ’011 PATENT OVERVIEW

The ’011 Patent issued from Application No. 17/105,012, filed 11/25/2020, and claims priority to 11/27/2019. Ex1001, Cover.

##### A. Specification

The ’011 Patent acknowledges that prior-art smartphones included “a circuit and antenna for enabling near field RF communication (NFC),” and “other wireless communication circuits and antennas,” including “MST” and “wireless power.” Ex1001, 1:22-33, 30:38-49. The ’011 Patent contends that space for antennas is limited, and purports to solve this by arranging coils on both sides of a PCB,

electrically connected by vias. Ex1001, 1:22-41, 41:50-42:4. This purported solution already existed. Ex1002 ¶¶32-58.

### **B. Prosecution History**

The '011 Patent issued without any Examiner rejections. During prosecution, the Applicant disclosed 70+ references, but failed to disclose material, invalidating references, including the references herein.

The Examiner concluded that “concentric C-shaped lines” forming “radially-extending” gaps in inner and outer coils through which NFC extension lines run was “not found in the prior art of record.” Ex1004, 1035-38. These limitations were well-known, however.

## **V. PRIOR ART OVERVIEW**

### **A. Seong**

Seong is a PCT application teaching a “smartphone[]” “antenna structure”:

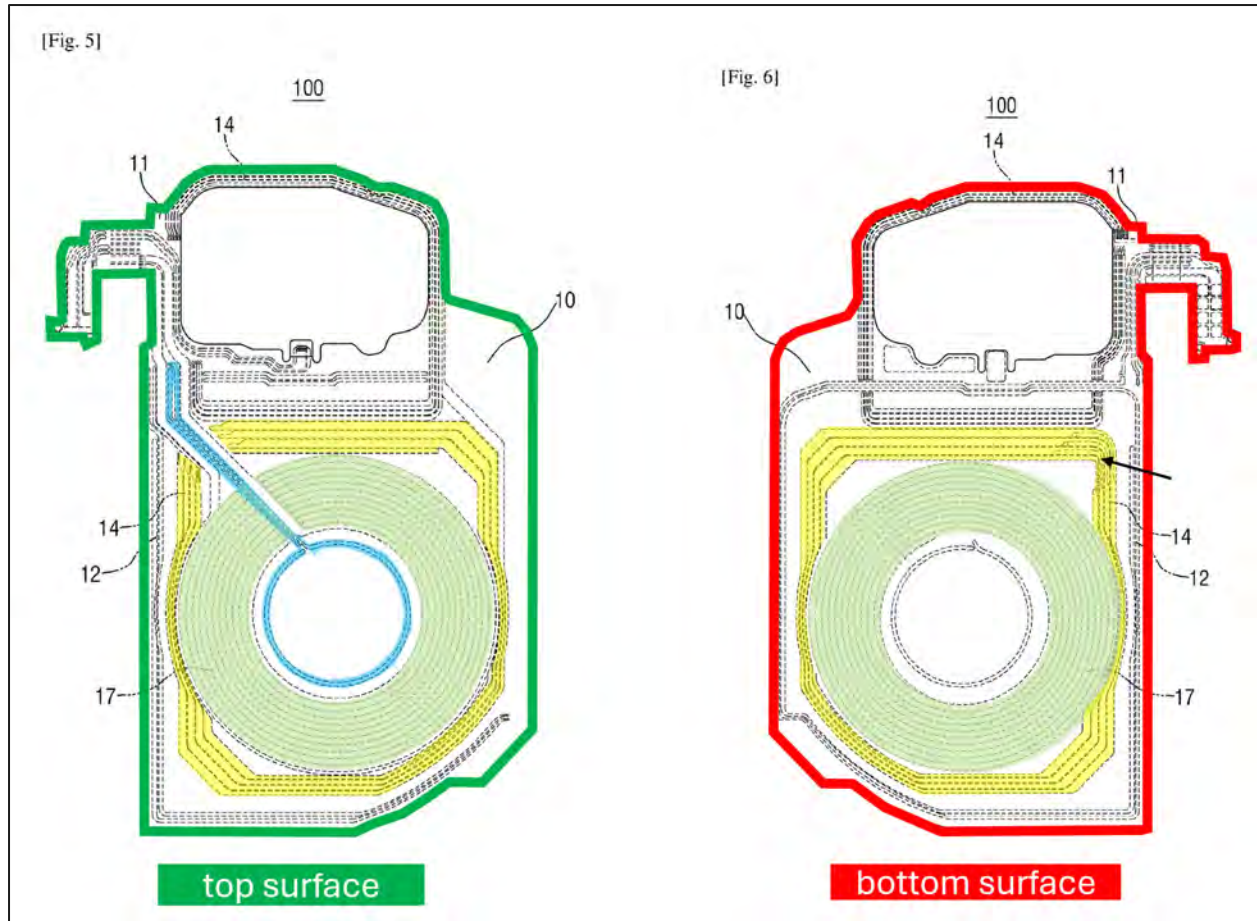

Ex1006, Abstract, Fig. 5-6; Ex1002 ¶63.

Seong discloses antennas formed on a substrate's top and bottom surfaces to “reduce the overall size of the antenna structure” and “to efficiently use the [smartphone's] internal space.” Ex1006, Abstract, ¶¶9-12, 16-17, 34-42, 63-69, 74, 80, Figs. 5-15, 17, Cls. 1, 6-7.

Seong uses multiple antenna types, including NFC, MST, and WPC. Ex1006, Abstract, ¶2. Seong depicts “WPC pattern 17” and the innermost portion of an “NFC pattern 12” as circular, and “MST pattern 14” as including rounded portions



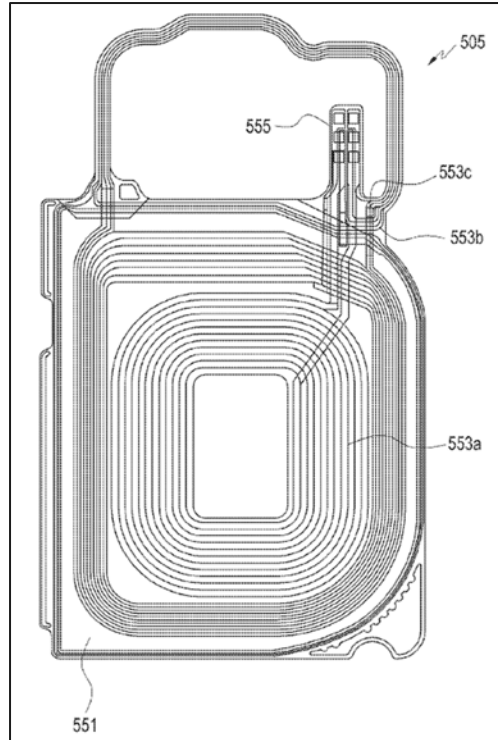

Ex1008, 17:4–19, Fig. 5B.

005Lee discloses antennas formed on a PCB's “front” and “back” surfaces:

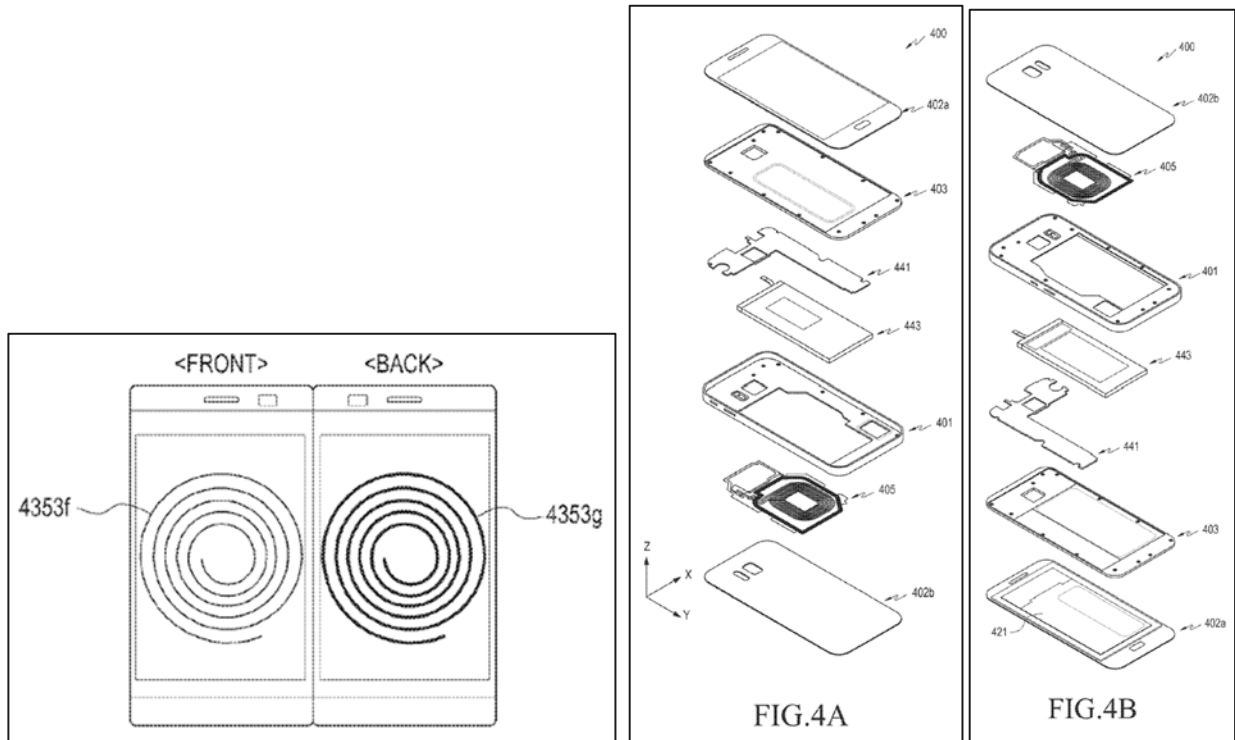

Ex1008, 17:24-28, 49:55-62, Figs. 4A-4B, 43D.

005Lee’s antennas may function as **NFC**, **MST**, and “**wireless charge coil[s]**,” and “can be configured in the form of a circle, and all the centers of the circles of respective coils coincide with each other”:

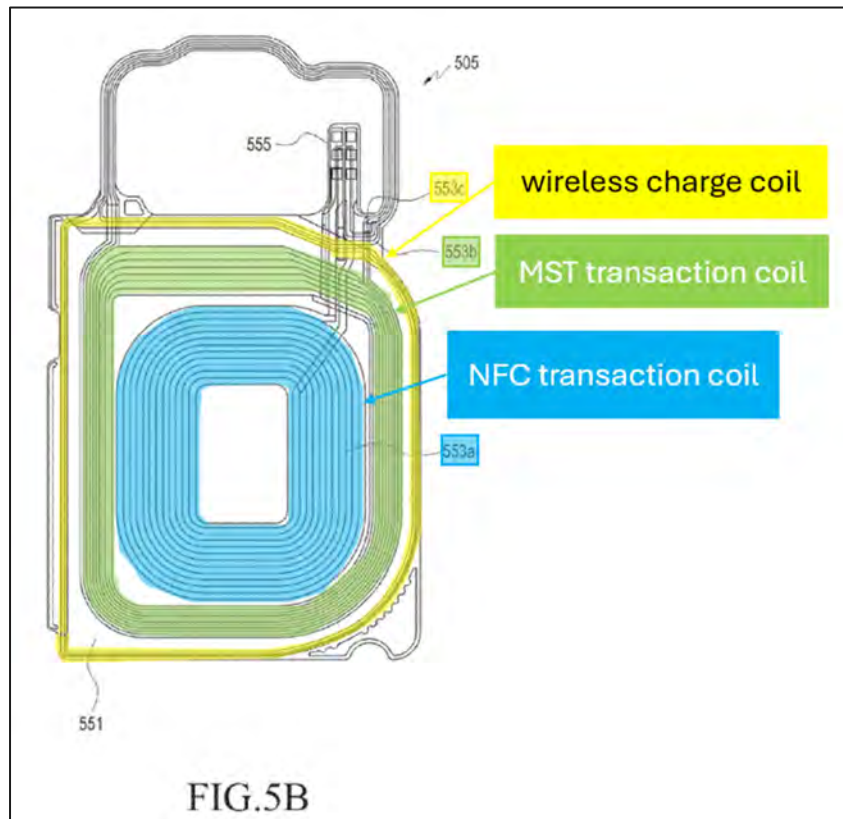

Ex1008, 17:67-18:4, 19:28-35, Fig. 5B; Ex1002 ¶68.

### C. Kang

Kang is a U.S. patent publication—published more than one year before the ’011 Patent’s earliest effective filing date—sharing an identical specification with the ’011 Patent apart from approximately one column of disclosure (second half of column 41 and first half of column 42) and a few figures (the ’011 Patent adds

Figures 45-55 while removing Kang Figures 15-20). Ex1012, Cover; Ex1013. Kang teaches a “smartphone” “antenna module”:

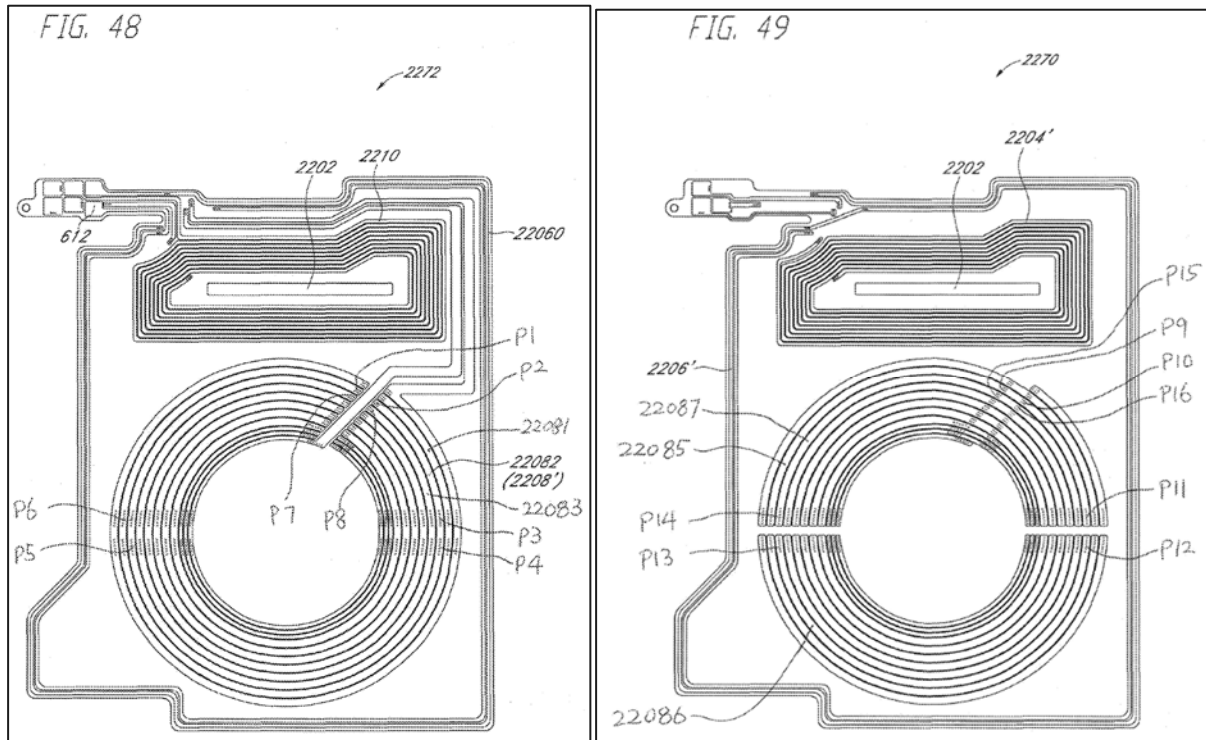

Ex1012, Abstract, Figs. 48-49; Ex1002 ¶69.

Kang discloses “improved layout[s]” and “shape[s]” for three-or-more coils that may be in a shape “different from that of the periphery of the PCB,” including “circular-spiral shape[s].” Ex1012 ¶¶33, 179, 248-49, Figs. 43, 46, 48-49. Kang’s coils can be concentric and each can perform MST, NFC, and wireless charging. *Id.*, ¶¶216, 238, 259, Fig. 49. Kang forms coils on both of the substrate’s opposing surfaces, connected using “vias.” *Id.*, ¶¶5-15, 76, 174-75, 231, 247-49, 261, 263, Figs. 43, 46, 48-49, Cl. 6.

Kang’s “coils may be connected in parallel”:

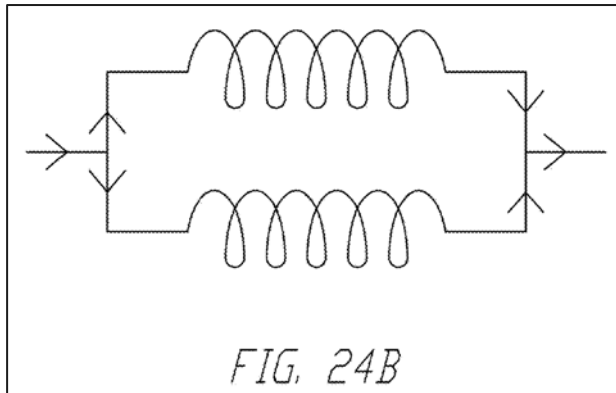

Ex1012 ¶¶214, 217, Fig. 24B.

**D. Cho**

Cho is a Korean patent publication teaching a smartphone “coil module”:

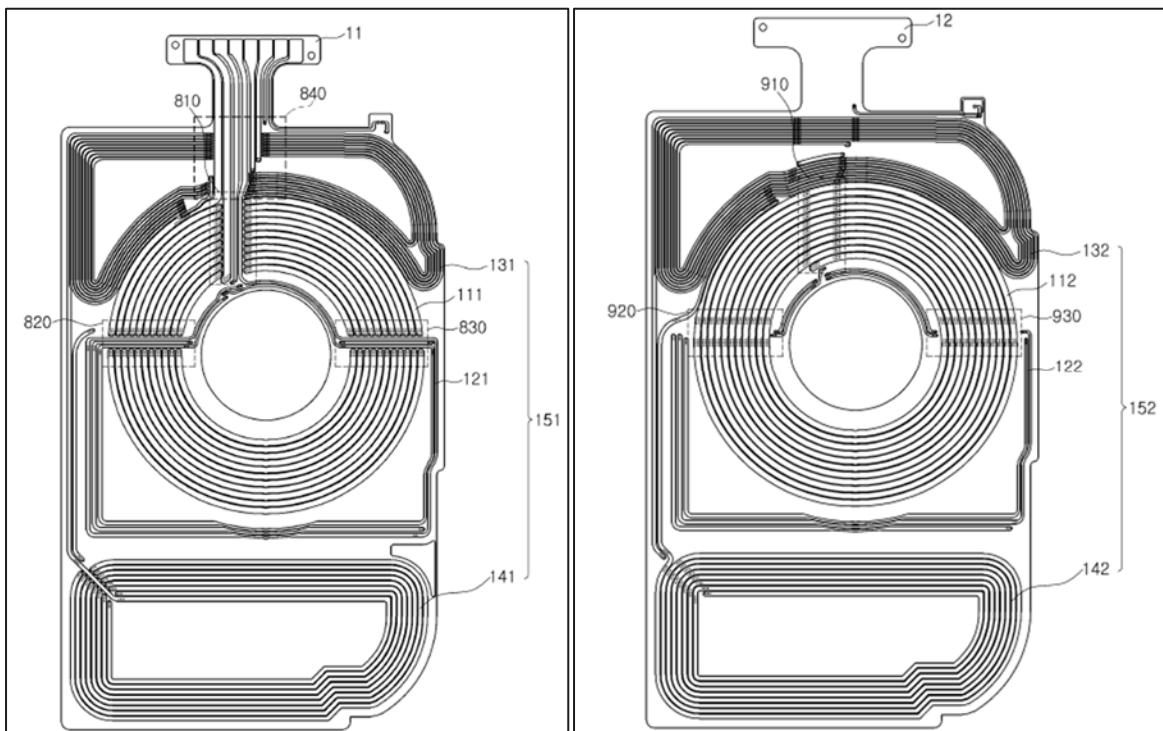

Ex1010, Figs. 8-9.

Cho discloses “coils for wireless communication”—including “NFC,” “wireless charging coil,” and a “second wireless communication coil”—on “both sides of the substrate,” connected through “a plurality of vias”:

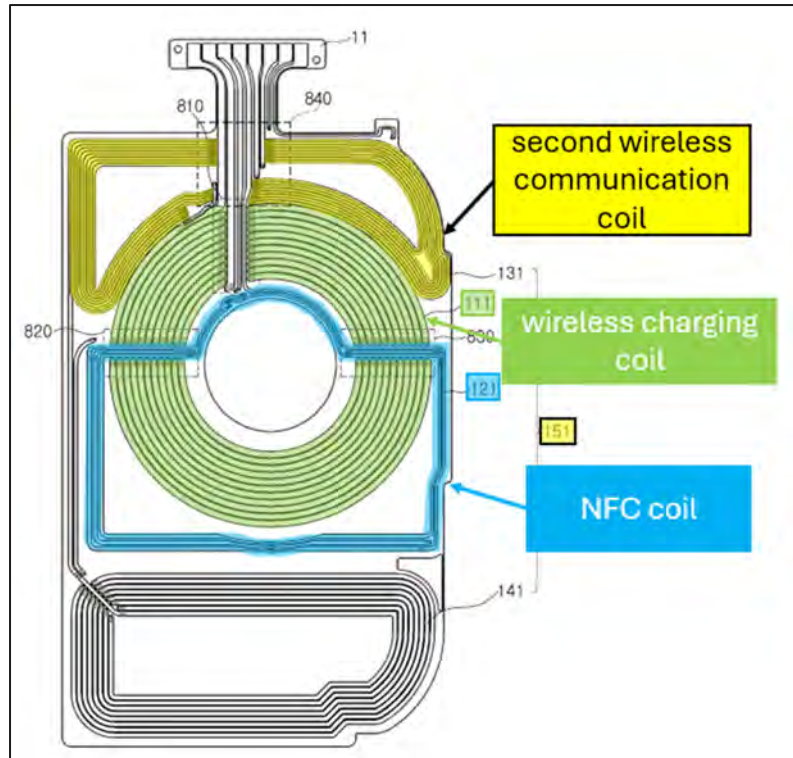

Ex1010 ¶¶3, 4, 5, 9, 75, 79, Fig. 8, Cls. 2, 10; Ex1002 ¶73.

For improved space efficiency, Cho uses “**empty spaces**” (gaps) in the coils through which **antenna extension lines** run:

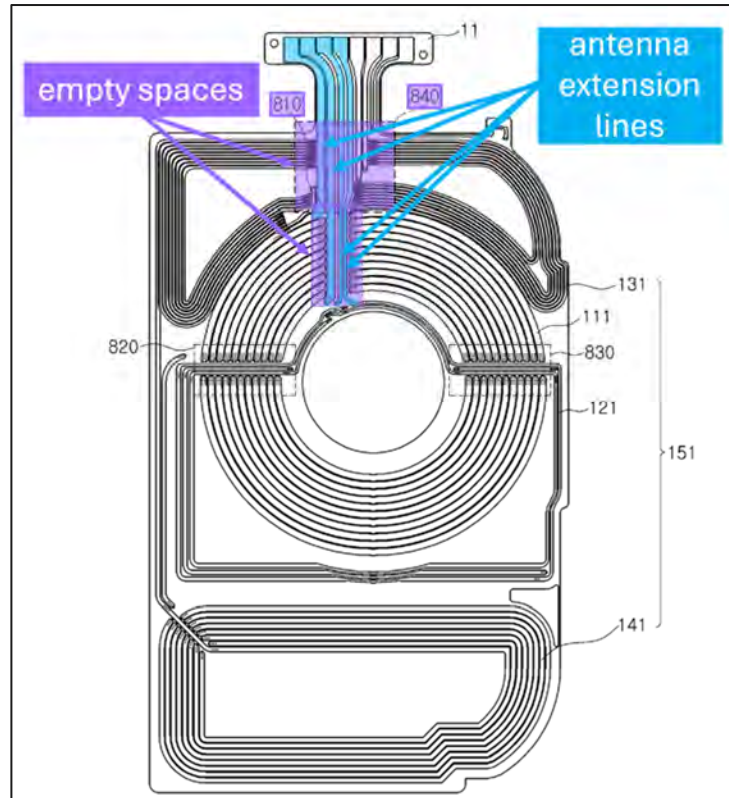

Ex1010, Fig. 8, ¶¶64, 68, 72; Ex1002 ¶74.

**E. Ahn**

Ahn is a U.S. patent publication teaching a smartphone “antenna” “coil assembly”:

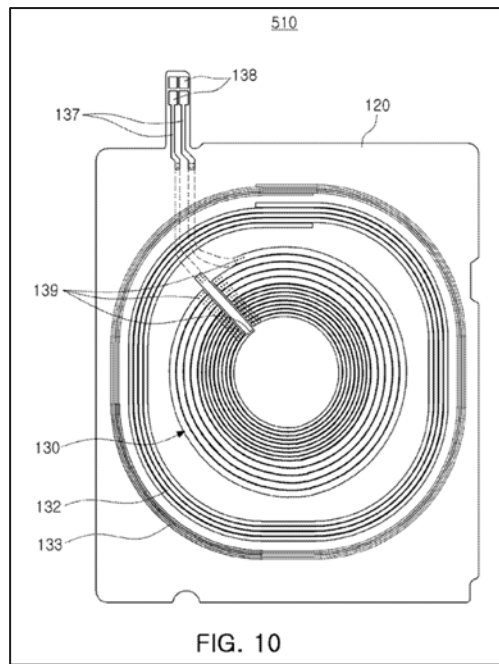
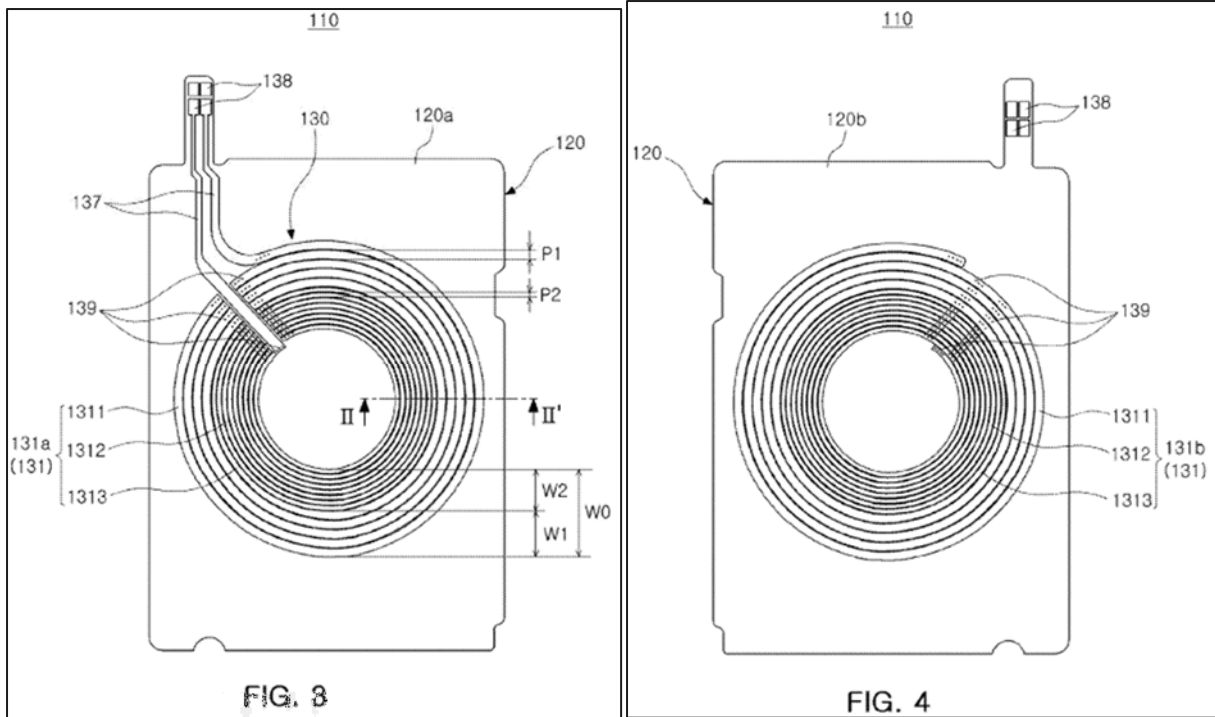

Ex1007, Abstract, ¶¶23, 47-48, 125, Cl. 18, Figs. 3-4, 10.

Ahn discloses antennas formed on opposing surfaces 120a and 120b of “substrate 120.” Ex1007 ¶¶4, 27-28, 65, 68, 71, 99-100, 127, Figs. 3-4, 10.

Ahn's coils include NFC, MST, and “wireless charging” functionality:

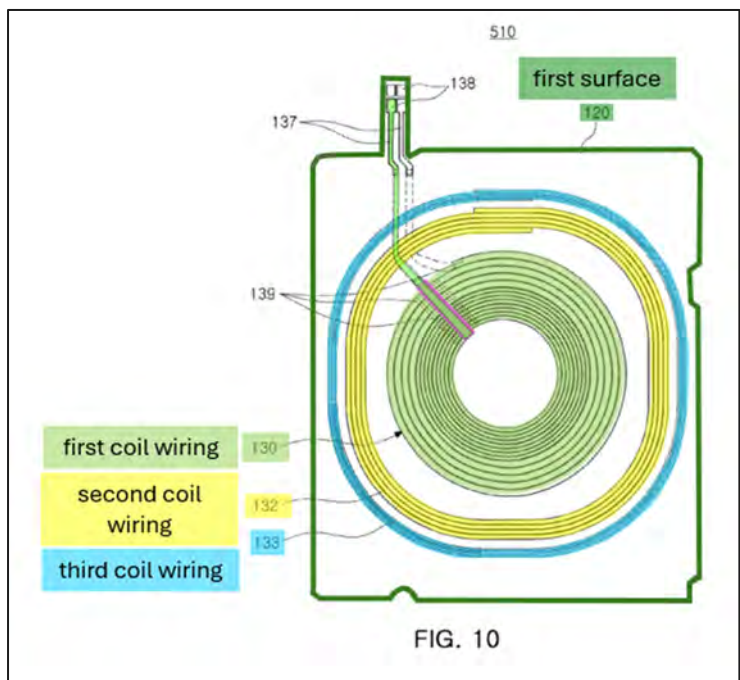

Ex1007 ¶¶18, 23, 125, Fig. 10; Ex1002 ¶77.

“[B]oth ends” of each of these coils “need to be connected to the connection pads 138” using “lead wirings 137” extending through “disconnected region[s]” of the coils in a “diameter (radial) direction.” Ex1007 ¶¶72-73, 124-25, Fig. 10.

#### F. 721Lee

721Lee is a U.S. patent publication teaching a smartphone antenna module:



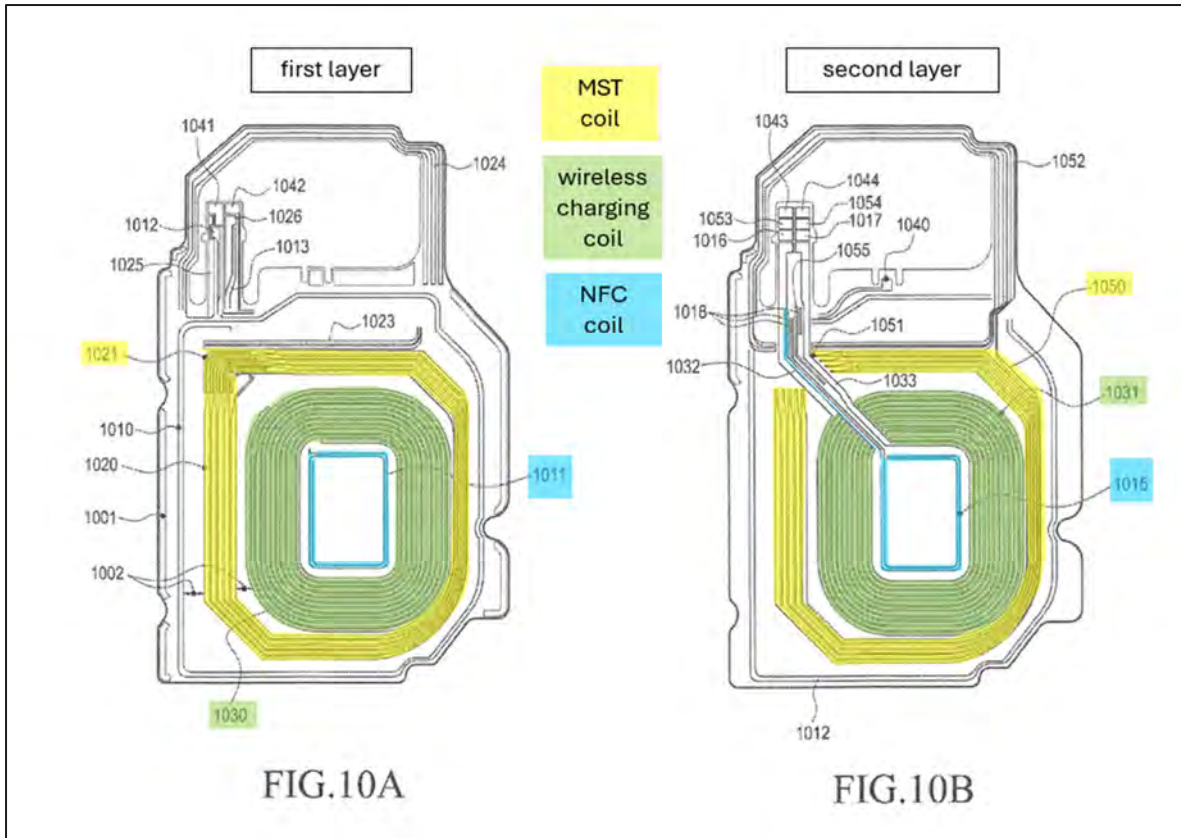

Ex1011, Abstract, ¶¶28-29, Figs. 10A-10B; Ex1002 ¶81.

721Lee's coils “may have the **opened loop** form” with gaps allowing “connect[ion] to the input/output terminals” using extension lines:

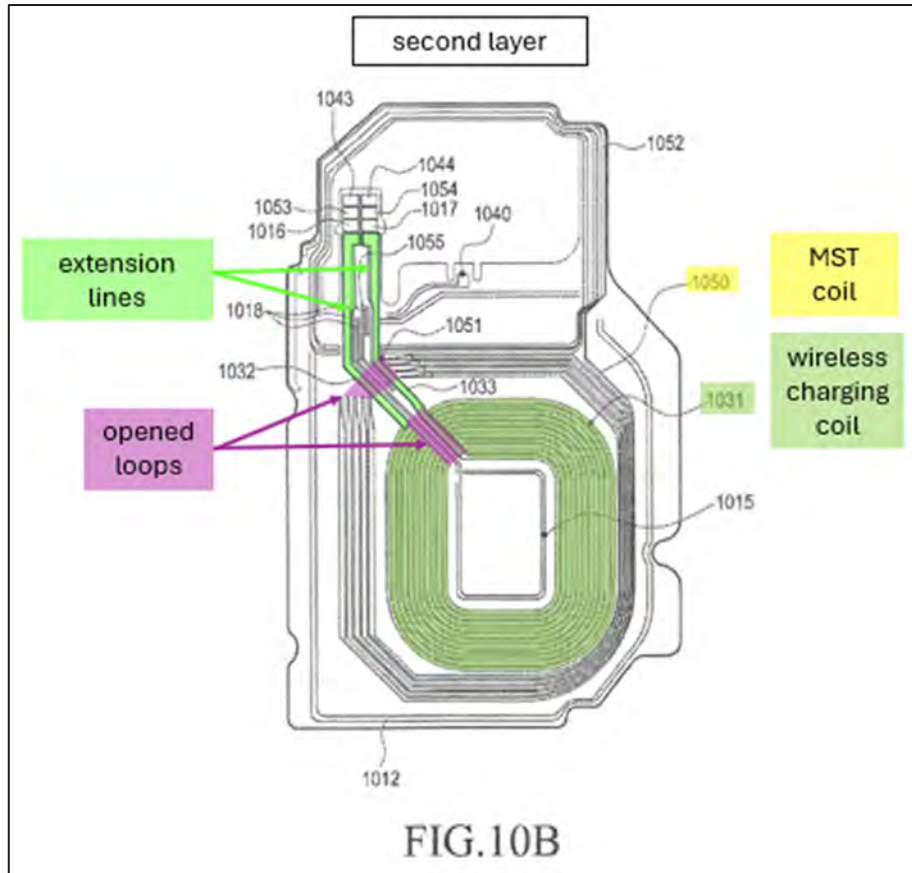

Ex1011 ¶140, Fig. 10B; Ex1002 ¶82.

## VI. LEVEL OF ORDINARY SKILL IN THE ART

A POSA would have had a bachelor's degree in electrical engineering or a similar field and 2-3 years of experience in antenna design, wireless charging, and/or contactless wireless communication. Additional education could offset less experience and vice versa, and a POSA could have also obtained similar knowledge and experience through other means. Ex1002 ¶¶30-31.

## VII. CLAIM CONSTRUCTION

Petitioners are unaware of any “prior claim construction determination” related to the '011 Patent. 37 C.F.R. §42.100(b). Petitioners do not believe any

claim construction is necessary to resolve the parties' controversy in this Petition, and the claims should be given their plain and ordinary meaning for purposes of this IPR.<sup>4</sup>

## **VIII. THE CHALLENGED CLAIMS ARE UNPATENTABLE**

### **A. Ground 1: Seong Renders Claims 1-6 Obvious In View Of Kang And Cho**

#### **1. Motivation To Combine Seong, Kang, And Cho**

These references overcome limited space in smartphones with space-efficient WPC, NFC, and MST antennas, optimizing shape and layout, placing coils on both sides of a substrate. Section V.

A POSA reading Seong would have been motivated to incorporate Kang's and Cho's teachings. Ex1002 ¶¶88-96. All three references teach antenna patterns on both sides of a substrate in a smartphone, including WPC, NFC, and MST antennas. *See, e.g.*, Ex1006, Abstract, Figs. 5-6, ¶¶63-64; Ex1012 ¶¶262-263, Figs. 46, 48-49, Cl. 6; Ex1010 ¶¶63-69, Figs. 8-9; Ex1002 ¶89. If Seong is found to not expressly teach a claimed limitation, as discussed below, it would have been obvious to a POSA to adopt well-known, predictable, and finite approaches taught by Kang

---

<sup>4</sup> Petitioners reserve all rights to raise claim construction arguments and other arguments in litigation.

and Cho to Seong's substrate to achieve wireless-communication functions in a space-efficient module. Ex1002 ¶89.

*First*, Seong's antenna patterns on its substrate's top and bottom surfaces are connected through vias. Ex1006 ¶¶4, 33-34, 77, Figs. 5-6; Ex. 1002 ¶90. If PO argues it discloses connection through some other means, a POSA would have found connections by vias obvious in view of Kang and Cho. Ex1012 ¶263, Cl. 6; Ex1010 Cl. 2, 10; ¶¶66-67, 73; Ex1002 ¶90. Via-connected coils can have increased surface area and improved communication performance in a space-efficient manner. Ex1002 ¶90.

A POSA would have reasonably expected success. Ex1002 ¶91. Vias were common and would have been obvious to try as there were a finite number of predictable solutions for connecting antenna patterns on different surfaces. *Id.*

*Second*, a POSA would have been motivated to use concentric, circular-shaped coils for Seong's WPC and MST patterns, as Kang teaches, and to connect and align their radially extending gaps, as Kang and Cho teach. Ex1002 ¶92. A POSA reading Seong's teaching that coil "shape and layout" "may be varied," Ex1006 ¶63, and reviewing Seong's depiction of WPC pattern 17 as circular, *id.*, Figs. 5-6, would have understood MST patterns with concentric circles were common and space-efficient. Ex1002 ¶92. Further, a POSA would have been motivated to look for references teaching layouts furthering Seong's space-

efficiency goal, including Kang and Cho. Ex1012 ¶¶3, 179, Figs. 46, 48-49; Ex1010 ¶¶5, 9; Ex1002 ¶92. Kang furthers that goal with concentric coils shaped “different from that of the periphery of the PCB,” including “circular-spiral shape[s].” Ex1012 ¶¶248-49, Figs. 43, 46, 48-49. Kang and Cho also further Seong’s space-efficiency goal with connected and aligned inner and outer gaps, which, similar to Seong’s disclosure, let extension lines through. Ex1012 Figs. 48-49; Ex1010 Fig. 8, ¶¶64, 68, 72; Ex1002 ¶92.

A POSA would have reasonably expected success. Ex1002 ¶93. There were a finite number of predictable coil shapes and arrangements, and concentric circles were common and yielded predictable results. *Id.* Seong teaches circular coils, including WPC antenna 17, and teaches other shapes could be used. Ex1006 ¶63, Figs. 5-6. Kang teaches using “different” coil shapes, including concentric circles. Ex1012 ¶¶33, 179, 248-49, Fig. 43, 46, 48-49. It was well-known that coils “can be wound in a variety of shapes,” including “circular.” Ex1010 ¶¶37, 57, Cls. 6, 14; Ex1002 ¶93.

***Third***, a POSA would have been motivated to electrically connect Seong’s WPC and MST patterns in parallel. Ex1002 ¶94. A POSA would have understood parallel connections may be more secure, and thus preferable for high-security, close-distance transactions, such as NFC payment transactions. *Id.* Seong does not explicitly disclose how its WPC and MST patterns are electrically connected. A

POSA would have been motivated to look to references teaching how to electrically connect inner and outer coils. *Id.* Kang teaches such coils can be electrically connected for improved performance flexibility and in one of two ways—“in series or in parallel”:

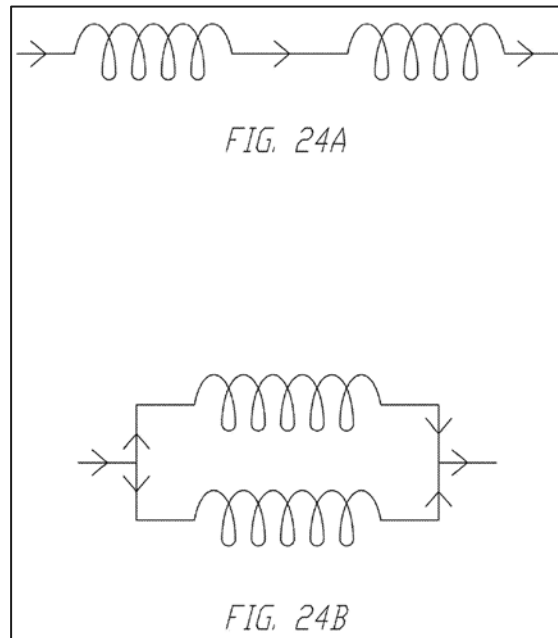

Ex1012 ¶¶150, 214, 217, 237, Figs. 24A, 24B; Ex1002 ¶94.

Electrically connecting Seong’s WPC and MST patterns in parallel was a simple design choice and would have been obvious to try. Ex1002 ¶95.

A POSA would have reasonably expected success. Ex1002 ¶96. Parallel electrical connection was well-known, straightforward, and achieved predictable results. *Id.*

**2. [1]**

**a. [1pre]<sup>5</sup>**

To the extent the preamble is limiting, Seong teaches it. Ex1002 ¶¶97-99.

Seong teaches a “smartphone[.]” “antenna structure [(100)]”:

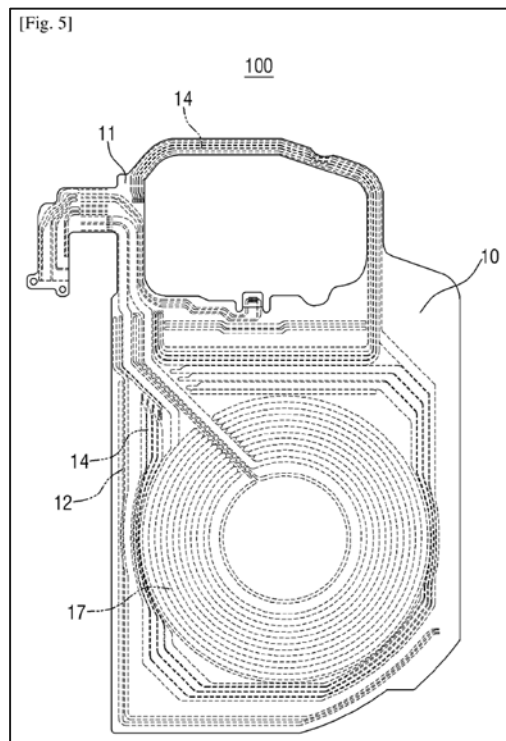

Ex1006 ¶¶2-3, 51-53, Fig. 5.

This is a smartphone antenna module including because it comprises multiple antennas. Ex1002 ¶¶99.

**b. [1a]**

Seong teaches this limitation. Ex1002 ¶¶100-101.

---

<sup>5</sup> See LIST OF CHALLENGED CLAIMS.

Seong teaches “antenna structure [(100)]” “include[s] a **substrate [(10)]** having” a “**bottom surface**” (first major surface) and a “**top surface**” (second major surface) on which “NFC pattern, MST pattern, [and/or] WPC pattern may be formed.” Ex1006 Abstract, ¶¶16, 23, 52. The “**top surface**” faces away from the “**bottom surface**”:

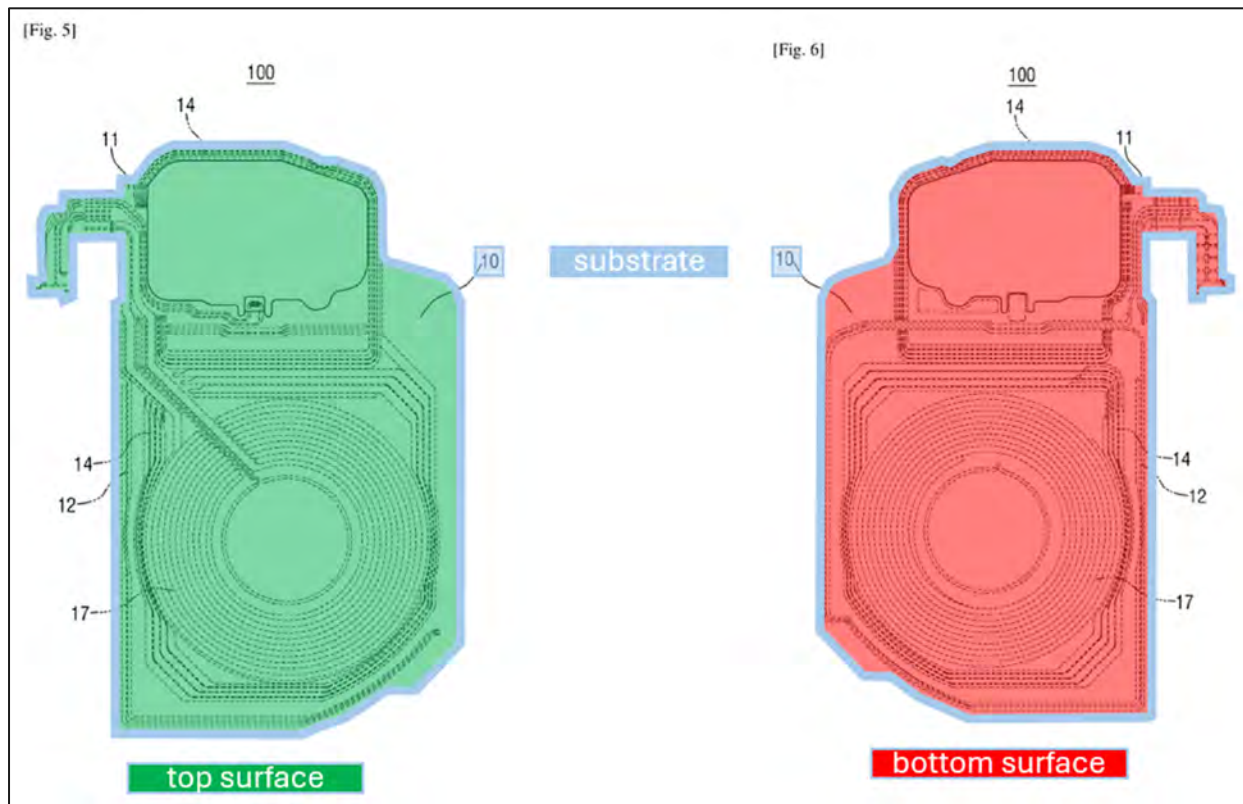

Ex1006, Figs. 5 (“antenna patterns formed on the top surface of the substrate”), 6 (“antenna patterns formed on the bottom surface of the substrate”), ¶¶34–35; *id.*, Figs. 7–13; Ex1002 ¶101.

**c. [1b]**

Seong teaches this limitation or alternatively, the Seong-Kang-Cho combination renders it obvious. Ex1002 ¶¶102-107.

In Seong, the “**bottom surface**” (first major surface) comprises a **first central portion**, “**WPC pattern 17**” (first inner ring portion) surrounding the **first central portion**, and “**MST pattern 14**” (first outer ring portion) surrounding “**WPC pattern 17**”:

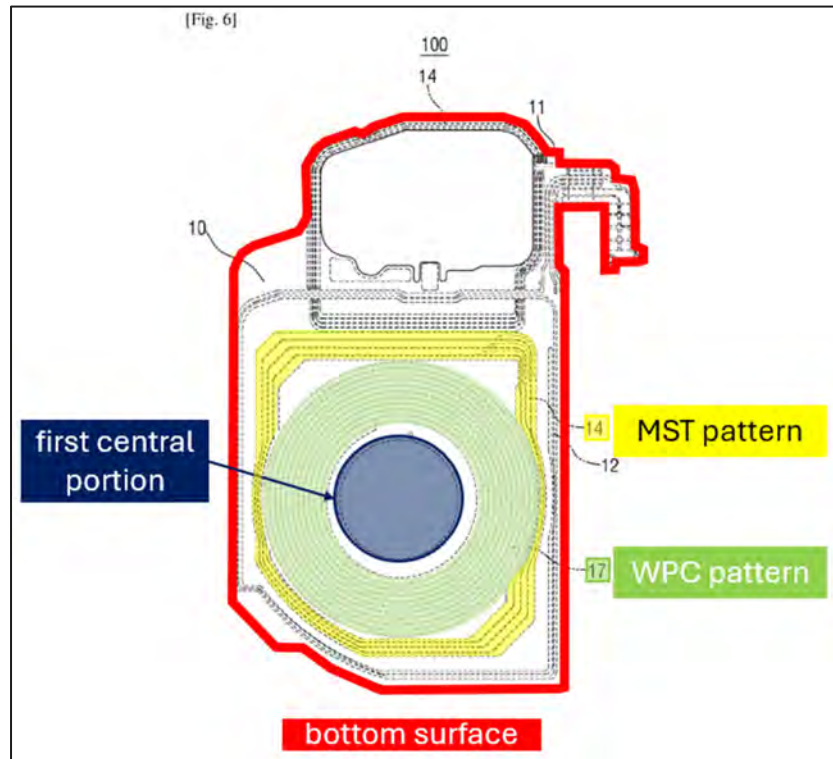

Ex1006 ¶64, Fig. 6; Ex1002 ¶103.

“**WPC pattern 17**” is a first inner ring portion and “**MST pattern 14**” is a first outer ring portion, including because they are hollow enclosures on Seong’s “**bottom surface**.” Ex1002 ¶104. This is at least as much disclosure as PO contends infringes:

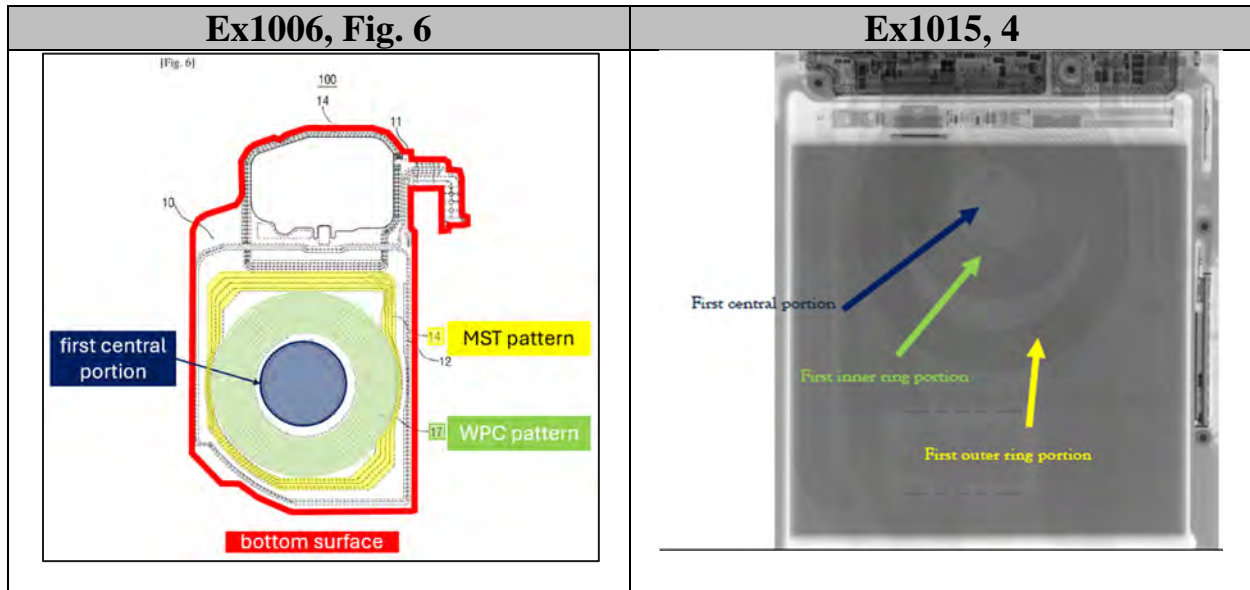

If PO argues “**MST pattern 14**” is not an outer ring portion because it is not circular, Seong renders this limitation obvious in view of Kang. Ex1002 ¶105. In Seong, “**WPC pattern 17**” is circular and Figures 5-6’s antenna patterns’ shapes, including “**MST pattern 14**,” “may be varied as needed.” Ex1006 ¶¶63, 64.

Kang teaches shaping coils “different from that of the periphery of the PCB,” including “circular-spiral shape[s],” and teaches using three-or-more concentric coils. Ex1012 ¶¶216, 248-49, Figs. 43, 46, 48-49.

Further, Seong’s “**WPC pattern**” and “NFC pattern” are “circular” and Figures 5-6’s antenna patterns’ shapes, including “**MST pattern**,” “may be varied.” Ex1006 ¶¶63, 66, 75. In view of these Seong and Kang teachings, a POSA would have been motivated to use a circular shape for Seong’s “**MST pattern 14**,” as

shown in modified Seong Figure 6 below, and would have reasonably expected success. Section VII.A.1.

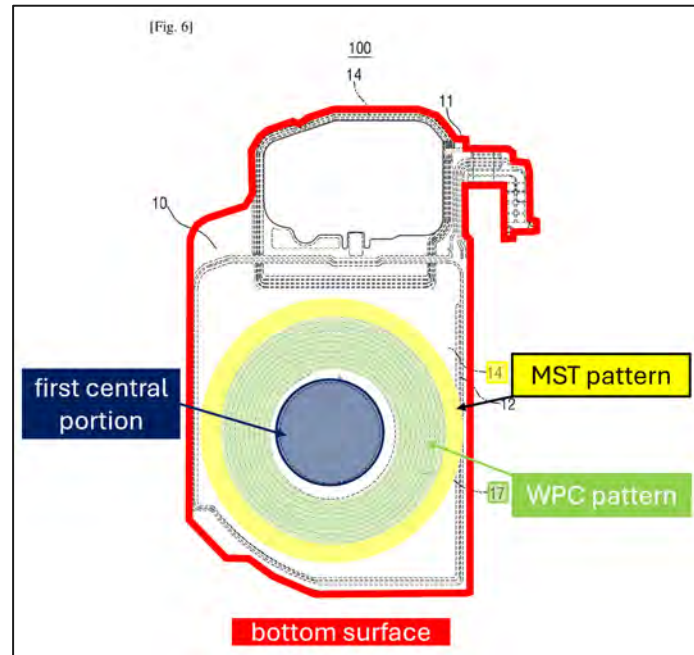

Ex1006, Fig. 6 (modified based on Ex1006 ¶¶63 and Ex1012 ¶¶33, 179, 216, 238, 248–49, Figs. 43, 46, 48–49); Ex1002 ¶107.

**d. [1c]**

Seong teaches this limitation, or alternatively, the Seong-Kang-Cho combination renders it obvious. Ex1002 ¶¶108-112.

In Seong, the “**top surface**” (second major surface) comprises a **second central portion**, “**WPC pattern 17**” (second inner ring portion) surrounding the **second central portion**, and “**MST pattern 14**” (second outer ring portion) surrounding “**WPC pattern 17**”:

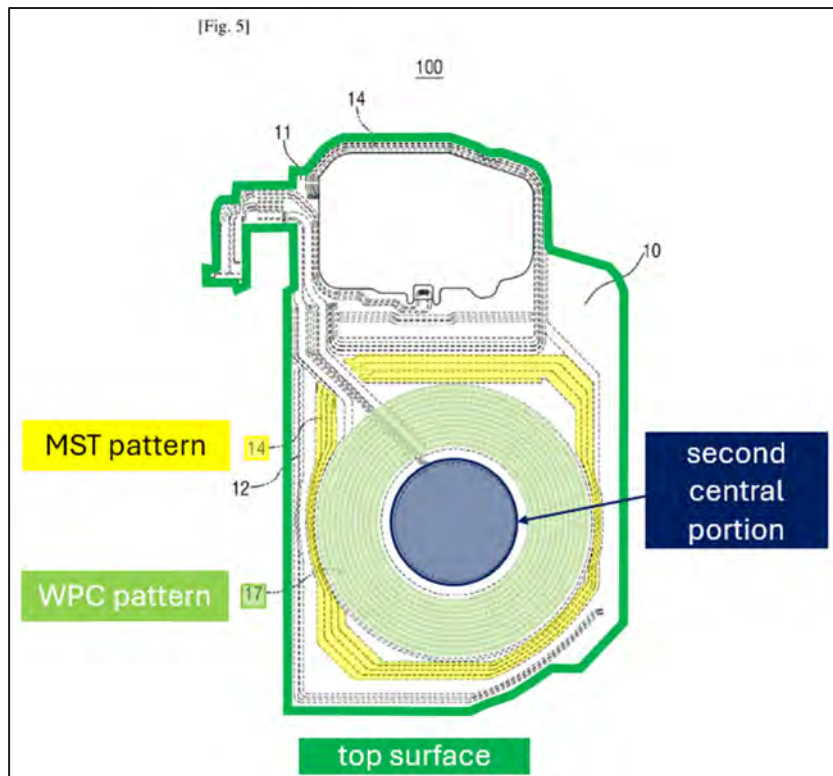

Ex1006 ¶¶63-64, Fig. 5; Ex1002 ¶109.

In Seong, the **second central portion** overlaps the **first central portion**, “**WPC pattern 17**” on the “**top surface**” overlaps “**WPC pattern 17**” on the “**bottom surface**,” and “**MST pattern 14**” on the “**top surface**” overlaps “**MST pattern 14**” on the “**bottom surface**”:

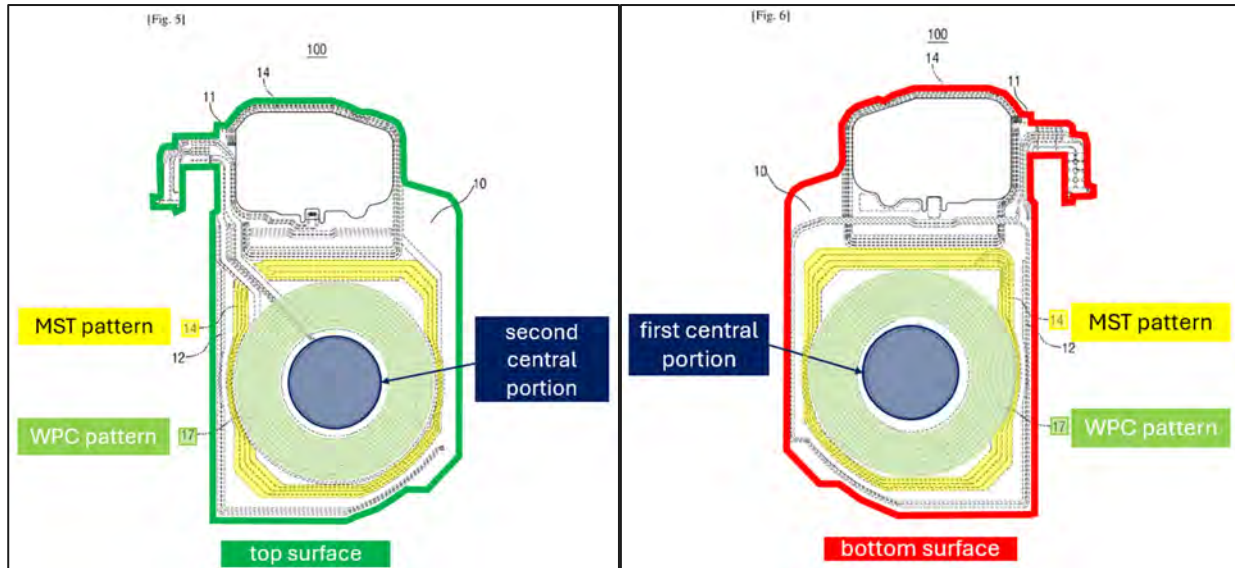

Ex1006 ¶¶63-64, Figs. 5, 6; Ex1002 ¶110.

This can be seen by overlaying Seong Figures 5-6:

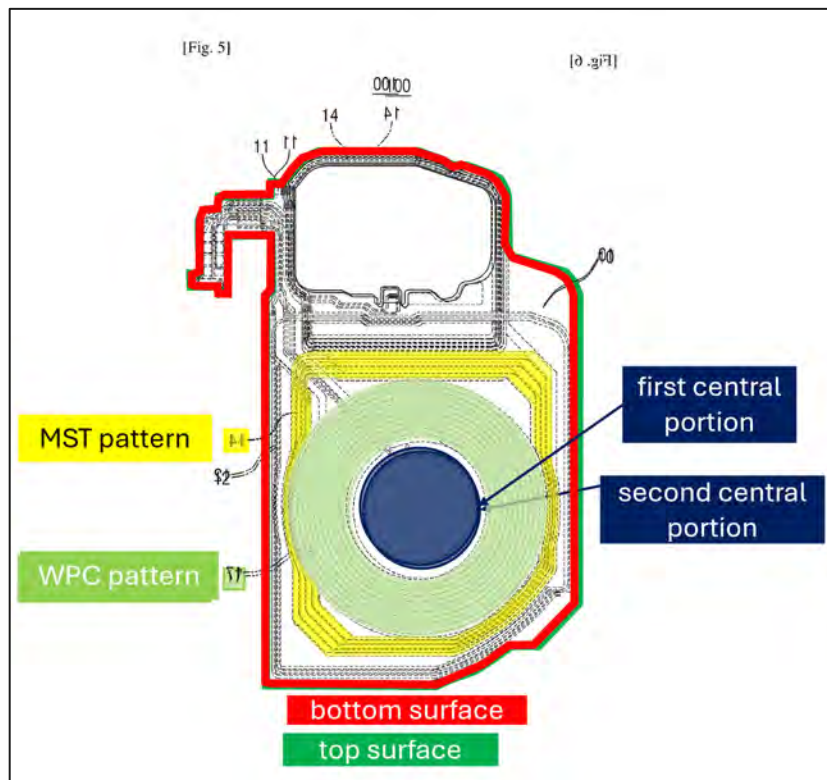

Ex1006, Figs. 5-6 (inverted and combined); Ex1002 ¶111.

A POSA would have understood “WPC pattern 17” and “MST pattern 14” on the “top surface” are the second inner and outer ring portions, respectively, and further, would have found it obvious to implement Seong’s teaching that “the shape and layout arrangement of the antenna patterns may ... var[y]” by using concentric, circular inner and outer rings formed on the “top surface,” as shown in modified Seong Figure 5 below, for the reasons discussed for Ground 1 Limitation [1b]:

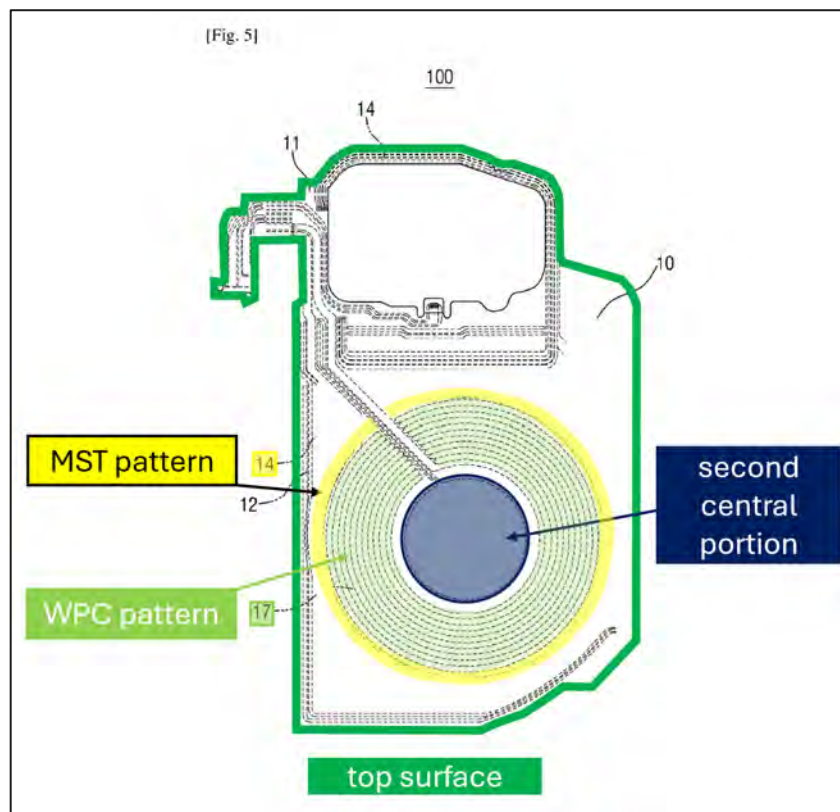

Ex1006, Fig. 5 (modified based on Ex1006 ¶¶63 and Ex1012 ¶¶33, 179, 216, 238, 248-49, Figs. 43, 46, 48-49); Ex1002 ¶¶112.

**e. [1d]**

Seong teaches this limitation. Ex1002 ¶¶113-116.

Seong teaches “a composite antenna structure in which an NFC pattern, an MST pattern, and a WPC pattern are [simultaneously] formed ... on a single substrate” (first antenna pattern). Ex1006 ¶¶1, 5, 9-10, 12, 34, Abstract, Fig. 6; Ex1002 ¶114.

In Seong, the first antenna pattern is formed on the “**bottom surface**” (first major surface) and comprises “**a WPC antenna**” (inner coil) formed on the portion occupied by “**WPC pattern 17**” (inner ring portion) and “**an MST antenna**” (outer coil) on the portion occupied by “**MST pattern 14**” (first outer ring portion):

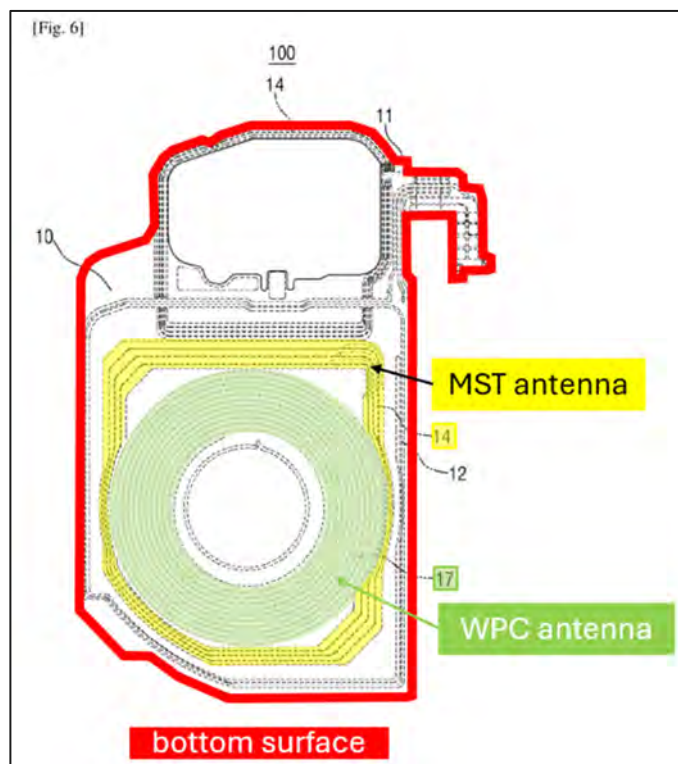

Ex1006 ¶¶63-64, Fig. 6; Ex1002 ¶115.

A POSA would have understood Seong’s smartphone “antennas” comprise coils, including because Seong depicts coils in Figs. 5-6, 11-13, and 15. Ex1002

¶116. Seong discloses MST, NFC, and WPC antennas. Ex1006, Abstract. Kang also teaches that such antennas comprise coils, which further shows a POSA would have understood Seong's antennas comprise coils. Ex1012 ¶¶47, 239; Ex1002 ¶116. The '011 Patent similarly describes "MST antenna" and "NFC antenna" as "coil antennas." Ex1001, 16:24-27, 30:42-45.

**f. [1e]**

Seong teaches this limitation. Ex1002 ¶¶117-118.

In Seong, a second antenna pattern formed on the "**top surface**" (second major surface) comprises "**an NFC antenna**" / "**NFC pattern 12**" formed on the **second central portion**, "**a WPC antenna**" / "**WPC pattern 17**" (inner antenna pattern) formed on the portion occupied by "**WPC pattern 17**" (second inner ring portion), and "**an MST antenna**" / "**MST pattern 14**" (outer antenna pattern) on the portion occupied by "**MST pattern 14**" (second outer ring portion):

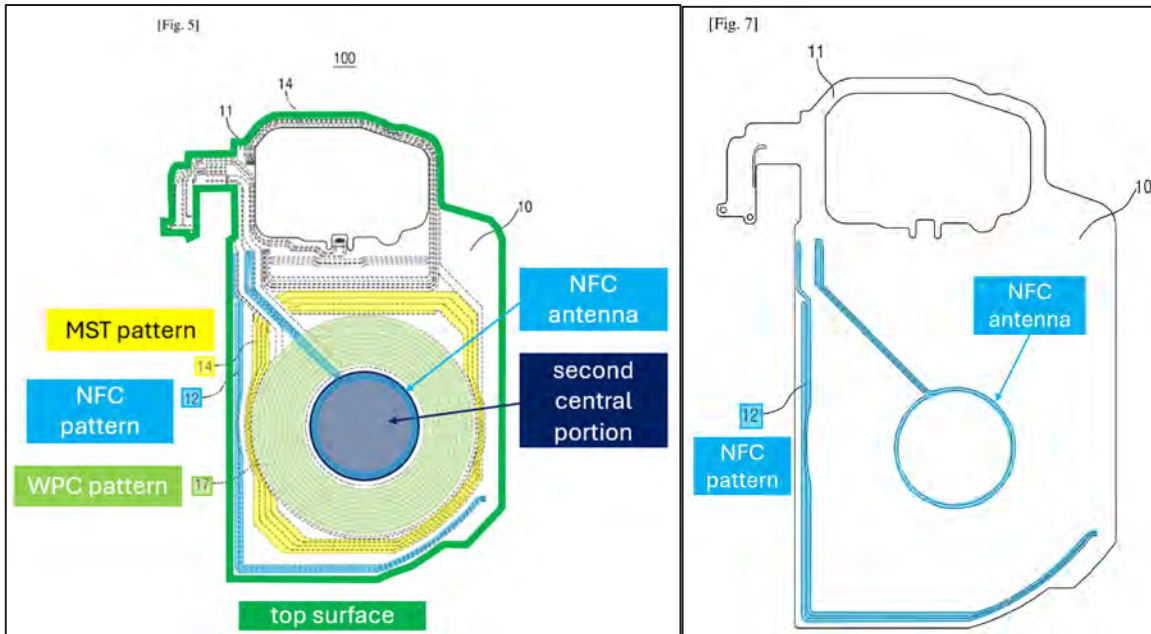

Ex1006, Figs. 5, 7, ¶36 (“FIG. 7 ... show[s] an NFC pattern formed on the top surface”); Ex1002 ¶¶118.

**g. [1f]**

Seong teaches this limitation, or alternatively, the Seong-Kang-Cho combination renders it obvious. Ex1002 ¶¶119-127.

In Seong, “**WPC antenna**” comprises a plurality of concentric **C-shaped lines** forming a **radially-extending inner gap** on “**WPC pattern 17**”:

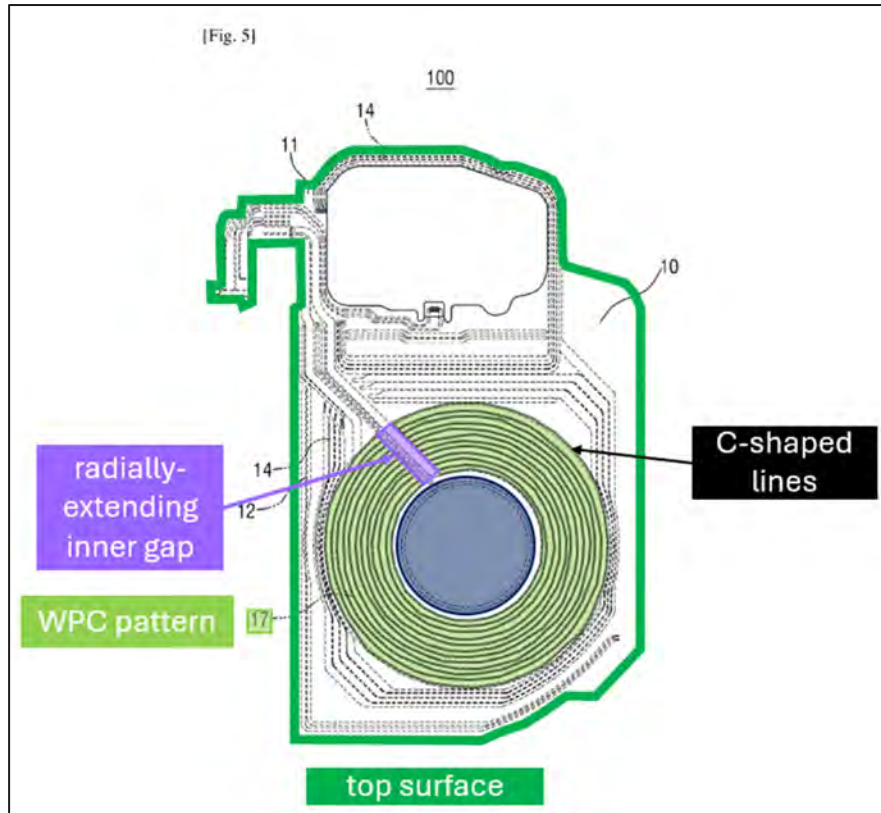

Ex1006, Fig. 5; Ex1002 ¶120.

This is at least as much disclosure as PO contends infringes:

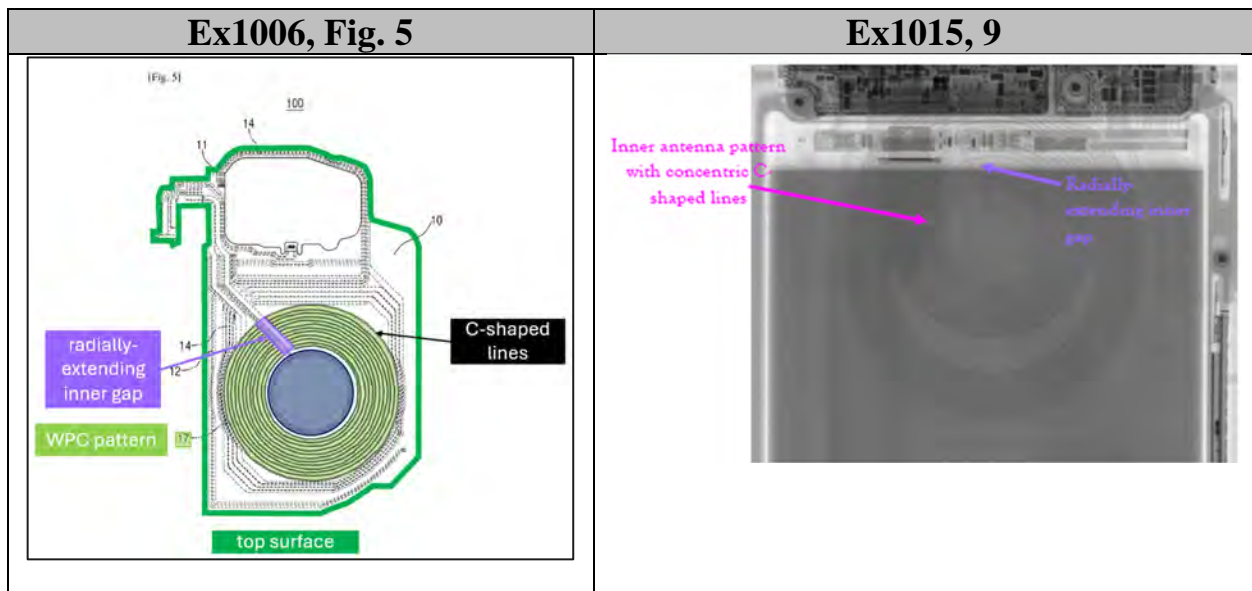

This is at least as much disclosure as the '011 Patent:

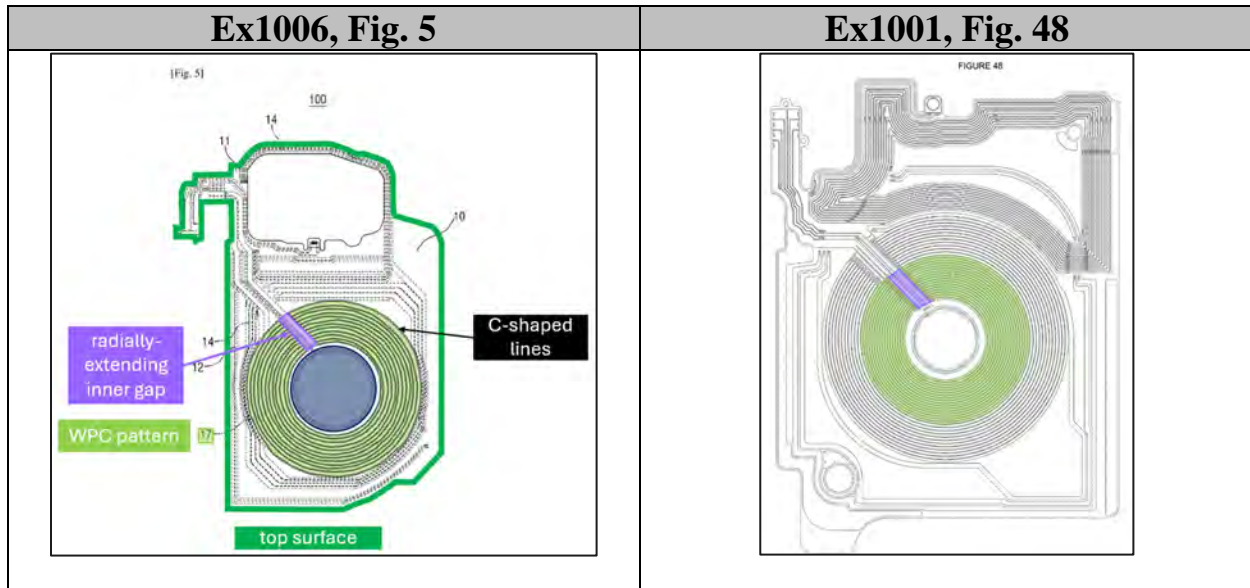

In addition, if Seong does not teach “**WPC antenna**” comprises a plurality of concentric C-shaped lines forming a radially-extending inner gap, this arrangement would have been obvious in view of Kang and Cho. Section VIII.A.1; Ex1002 ¶123.

Kang teaches multiple ways of comprising an inner antenna pattern out of a plurality of concentric C-shaped lines forming a radially-extending inner gap. Ex1002 ¶124. Kang Figure 49 teaches “**first coil antenna**” comprises concentric C-shaped “**line segments of coil**” forming **radially-extending inner gaps**:

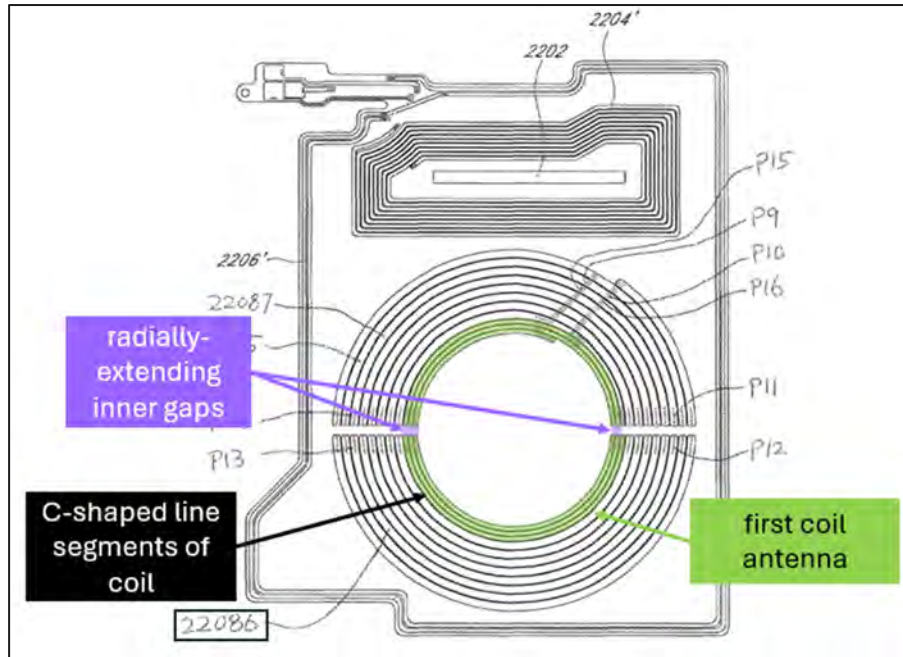

Ex1012, ¶¶28, 182, 262–63, Fig. 49; Ex1002 ¶124.

Kang Figure 48 teaches this too:

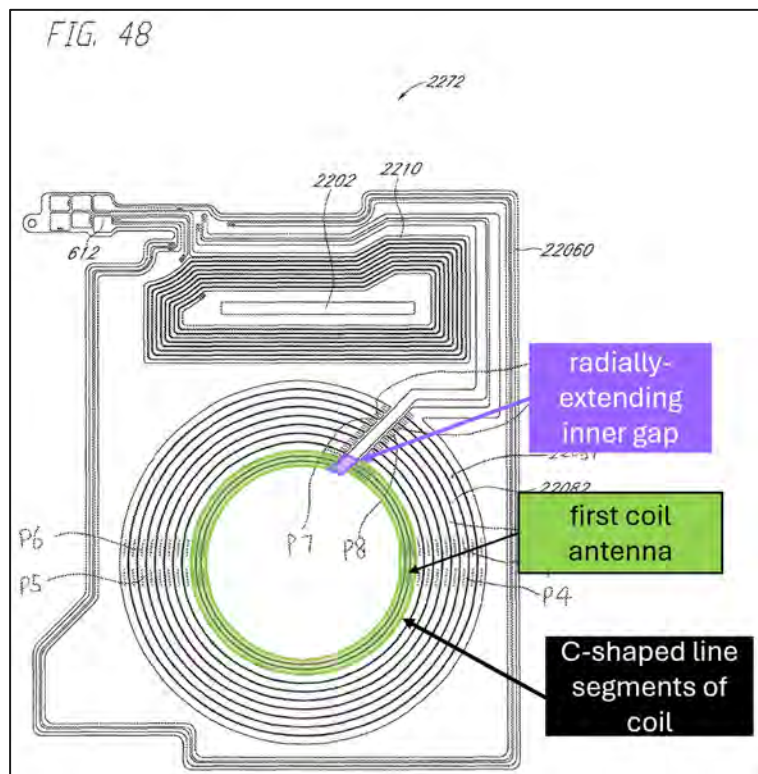

Ex1012, Fig. 48; Ex1002 ¶125.

If PO incorrectly argues Kang does not teach an inner coil comprising concentric C-shaped lines forming a radially-extending inner gap as described above, a POSA would have found this obvious in view of Cho. Ex1002 ¶126. Cho teaches an inner antenna pattern comprising a plurality of concentric **C-shaped lines** forming a radially extending inner gap on the second inner ring portion. Cho teaches “**wireless charging coil 111** has **hollow spaces** on one surface 11 of the substrate in some regions **810, 820, 830**”:

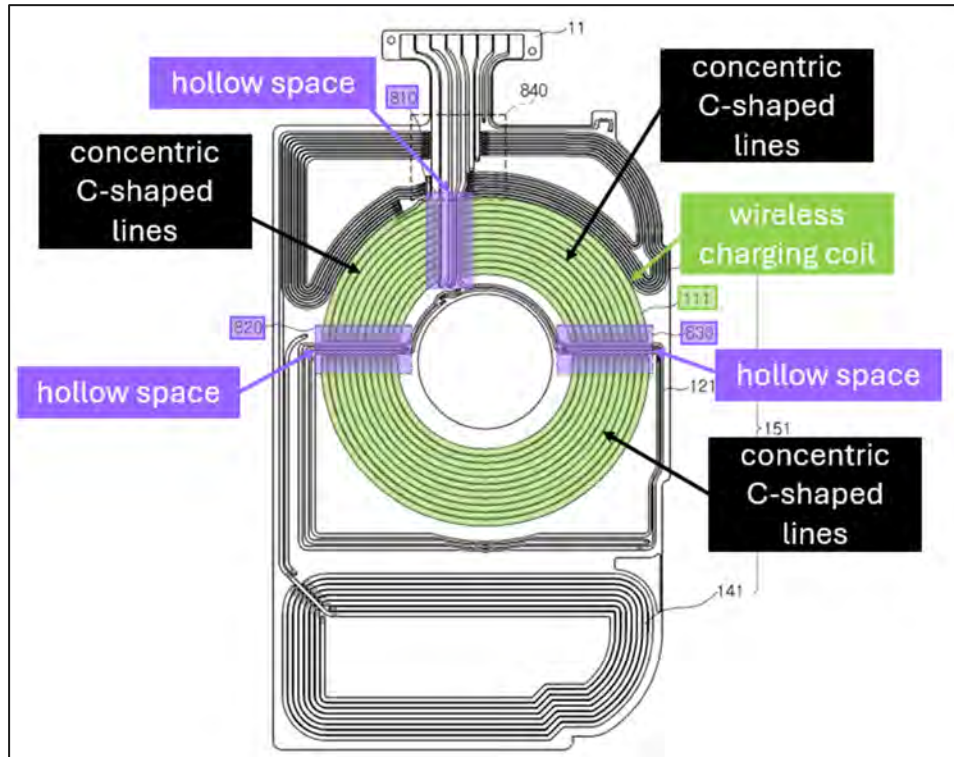

Ex1010 ¶64, Fig. 8; Ex1002 ¶126.

Cho’s “**wireless charging coil 111**” is an inner antenna pattern comprising a plurality of **concentric C-shaped lines** forming “**hollow spaces ... 810, 820, 830**” (radially-extending inner gaps). Ex1002 ¶127. Cho’s “**hollow spaces**” beneficially

let extension lines, including **wireless-charging coil extension lines** and **NFC antenna extension lines**, run through coils without touching them:

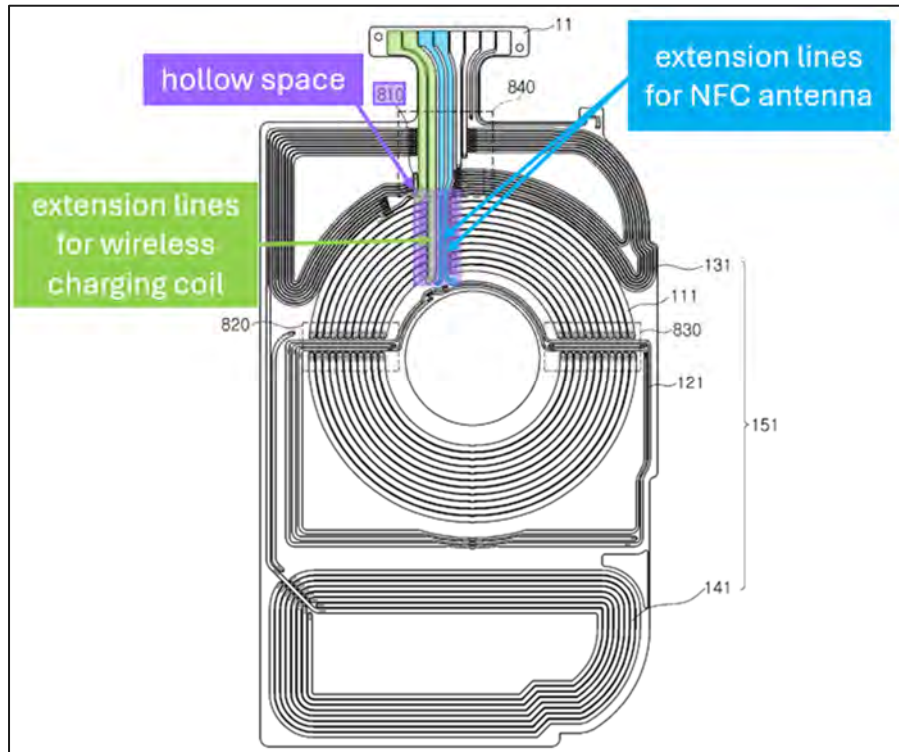

Ex1010 ¶64, Fig. 8; *id.* ¶61 (“the first wireless communication coil 120 may support ... NFC”), Fig. 4 (depicting NFC coil 120); Ex1002 ¶127.

**h. [1g]**

Seong teaches this limitation, or alternatively, the Seong-Kang-Cho combination renders it obvious. Ex1002 ¶¶128-137

Seong teaches “**MST antenna**” comprises a plurality of **concentric C-shaped lines** forming a **radially-extending outer gap** on “**MST pattern 14**”:

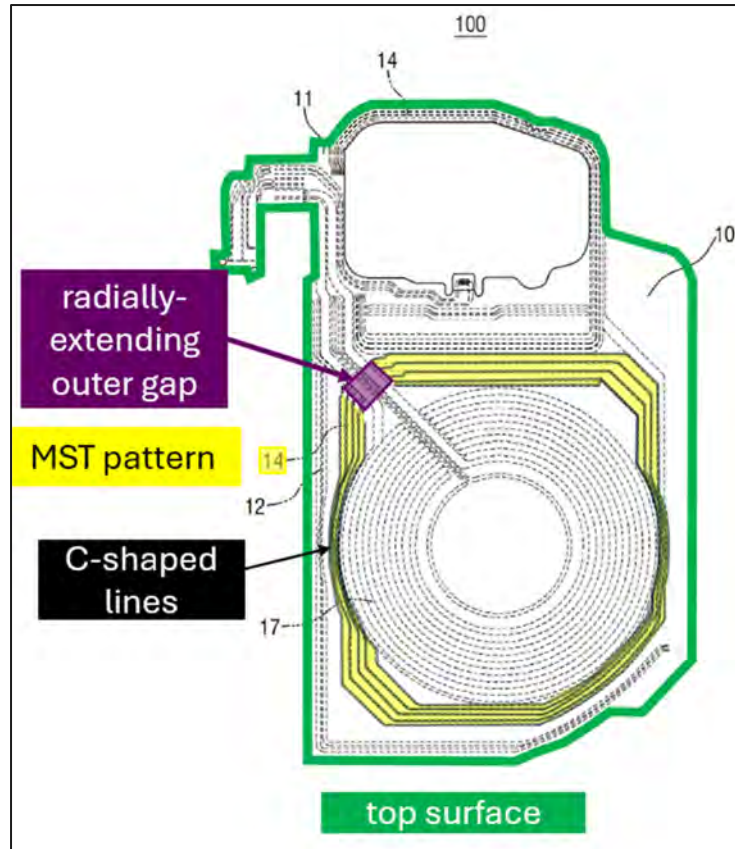

Ex1006, Fig. 5; Ex1002 ¶129.

This is at least as much disclosure as PO contends infringes:

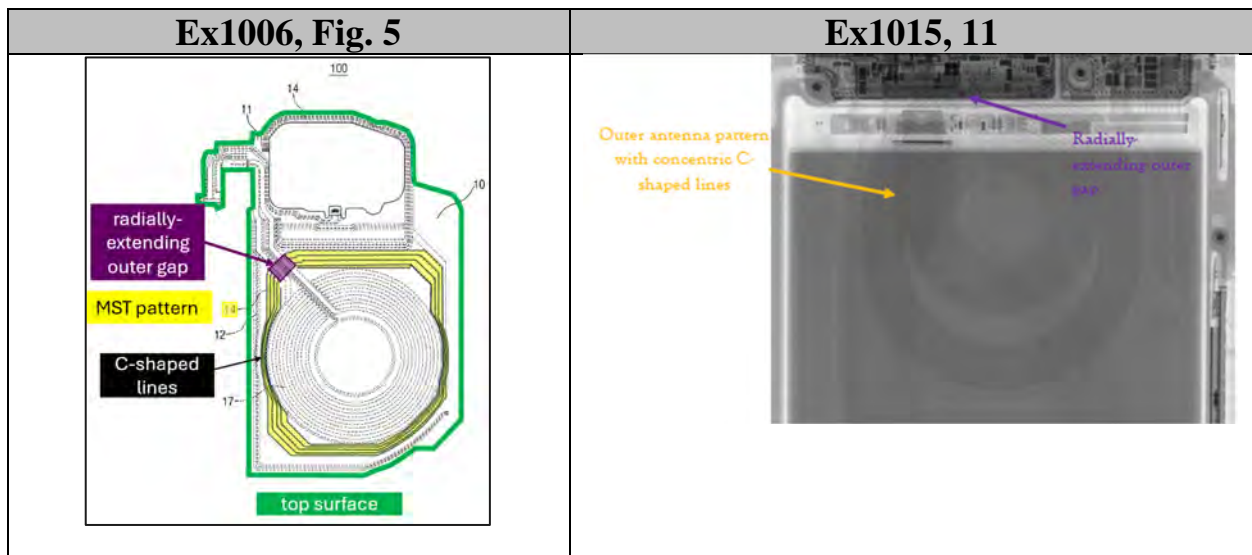

This is at least as much disclosure as the '011 Patent:

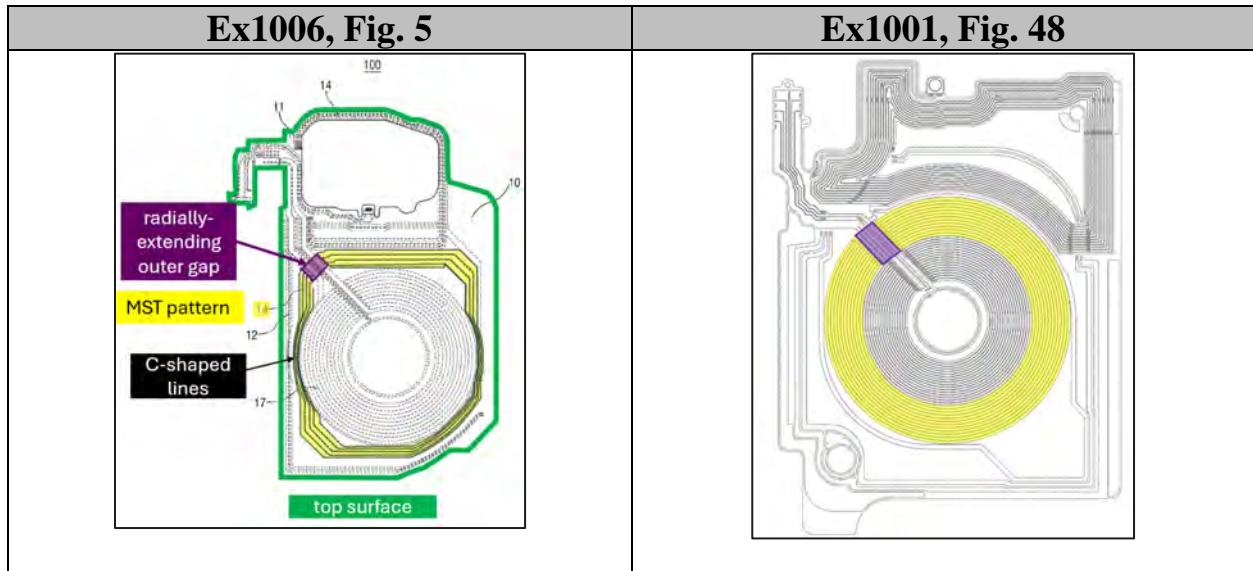

In addition, if PO argues Seong does not teach this limitation, as explained for Ground 1 Limitation [1c], it would have been obvious to use a circular shape for “**MST pattern 14**” on Seong’s “**top surface.**” Seong’s “**WPC pattern**” and “NFC pattern” are “circular” and Figures 5-6’s antenna patterns’ shapes, including “**MST pattern,**” “may be varied.” Ex1006 ¶¶63, 66, 75. When so configured, Seong’s “**MST antenna**” comprises a plurality of concentric C-shaped lines forming a **radially-extending outer gap:**

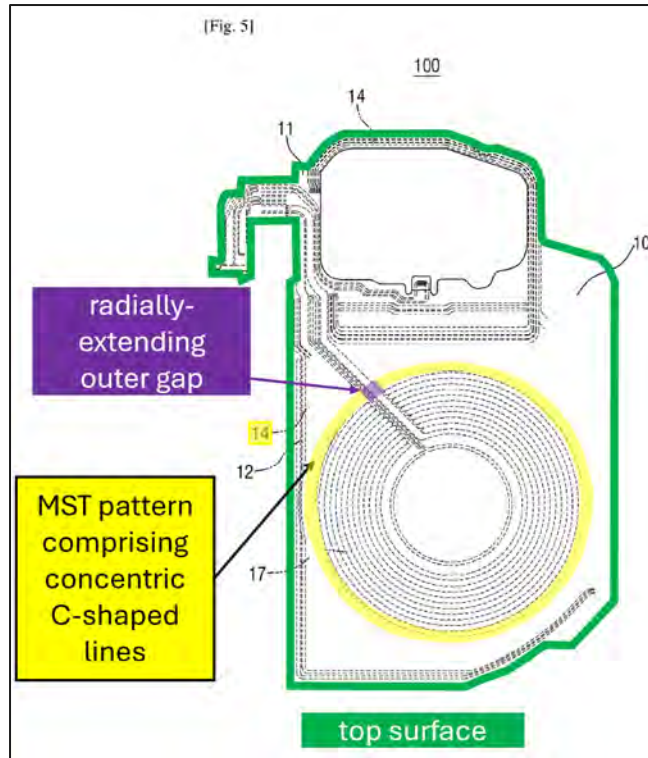

Ex1006, Fig. 5 (modified based on Ex1006 ¶¶63 and Ex1012 ¶¶33, 179, 216, 238, 248-49, Figs. 43, 46, 48-49); Ex1002 ¶132.

In addition, if PO argues a circular “**MST antenna**” in Seong does not teach this limitation either, this arrangement would have been obvious in view of Kang and Cho. Section VIII.A.1; Ex1002 ¶¶133-137.

Kang teaches multiple ways of comprising an outer antenna pattern out of a plurality of concentric C-shaped lines forming a radially-extending outer gap. Kang Figure 49 teaches “**second coil antenna**” comprising a plurality of concentric C-shaped “**line segments of coil ... 22085, 22086 and 22087**” forming a **radially-extending outer gap** on the “**second coil antenna**”:

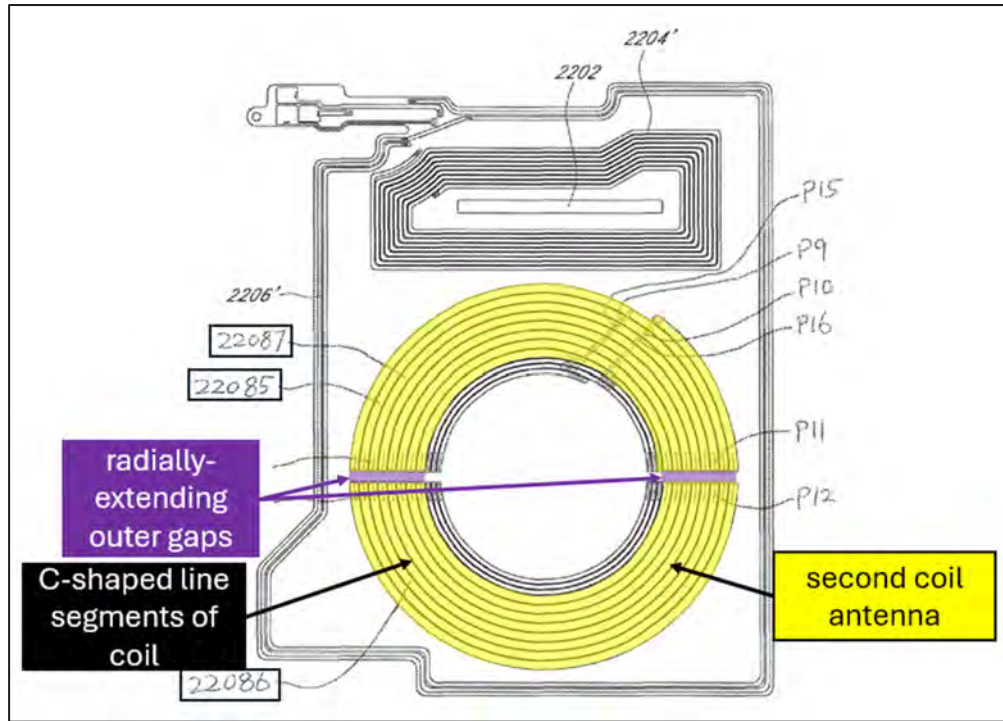

Ex1012 ¶¶26, 262, Fig. 49; Ex1002 ¶134.

Kang Figure 48 teaches this too:

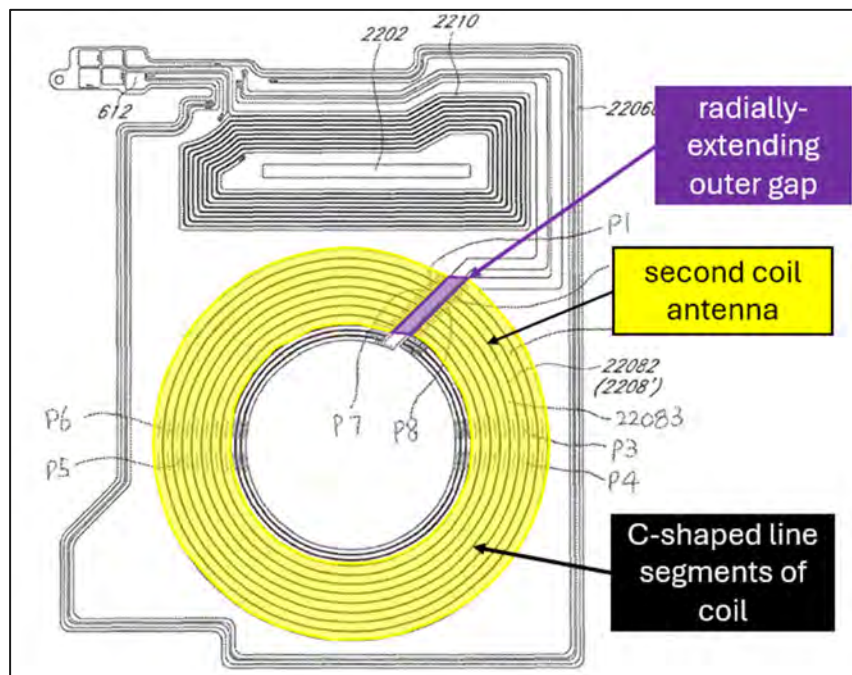

Ex1012 ¶262, Fig. 48; Ex1002 ¶135.

If PO incorrectly argues Kang does not teach an outer coil comprising concentric C-shaped lines forming a radially-extending outer gap as described above, a POSA would have found this obvious in view of Cho. Ex1002 ¶¶136-137. Cho teaches an outer antenna pattern comprising a plurality of concentric **C-shaped lines** forming a radially-extending outer gap on the second outer ring portion. Cho teaches “**second wireless communication coil 151** also has **hollow spaces** on one surface 11 of the substrate in some regions **840**” (radially-extending outer gap on the second outer ring portion):

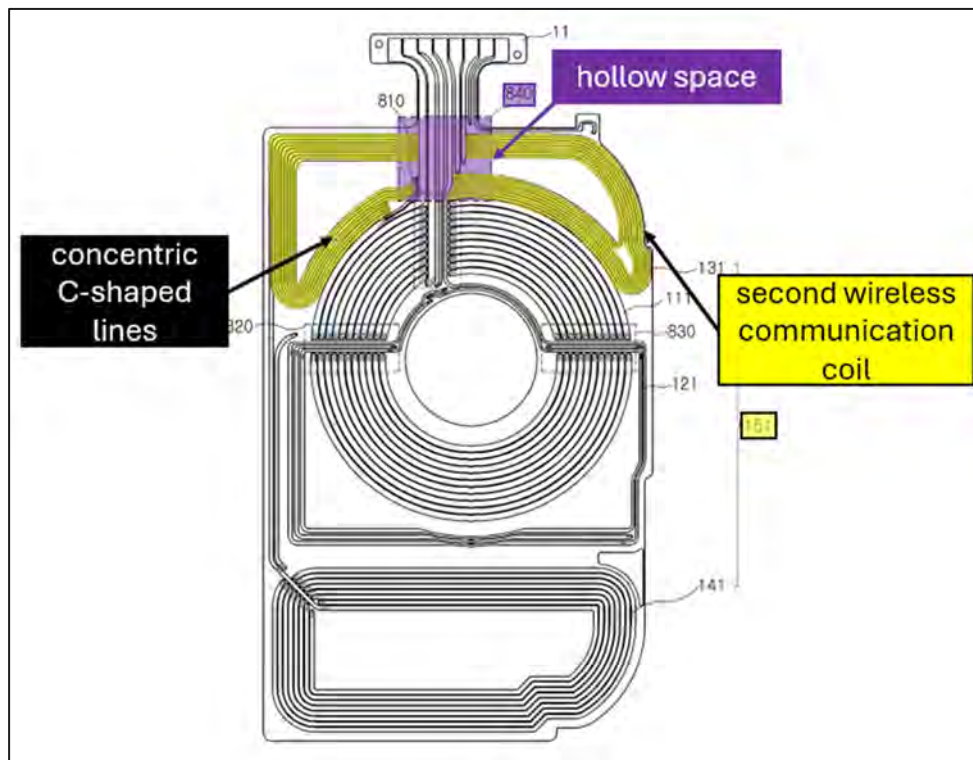

Ex1010 ¶68, Fig. 8; Ex1002 ¶136.

As explained for Ground 1 Limitation [1f], Cho teaches its “**hollow spaces**” beneficially let extension lines run through, improving space efficiency. This is at least as much disclosure as PO contends infringes:

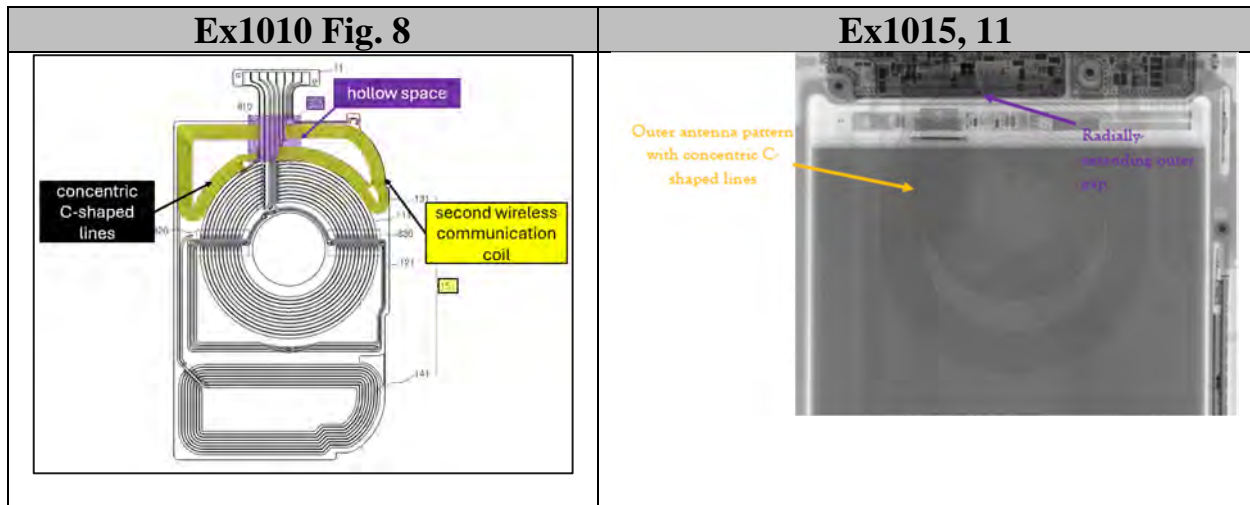

**i. [1h]**

Seong teaches this limitation, or alternatively, the Seong-Kang-Cho combination renders it obvious. Ex1002 ¶¶138-146.

Seong teaches the **radially-extending outer gap** on “**MST pattern 14**” and the **radially-extending inner gap** on “**WPC pattern 17**” are connected and aligned in a **radial direction**:

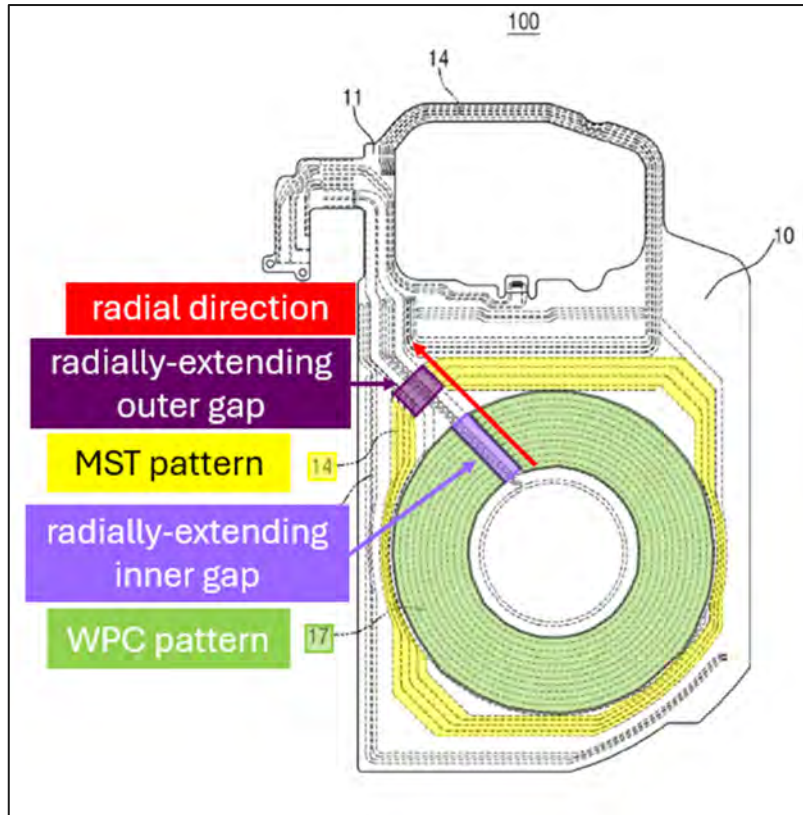

Ex1006, Fig. 5; Ex1002 ¶139.

This is at least as much disclosure as PO contends infringes:

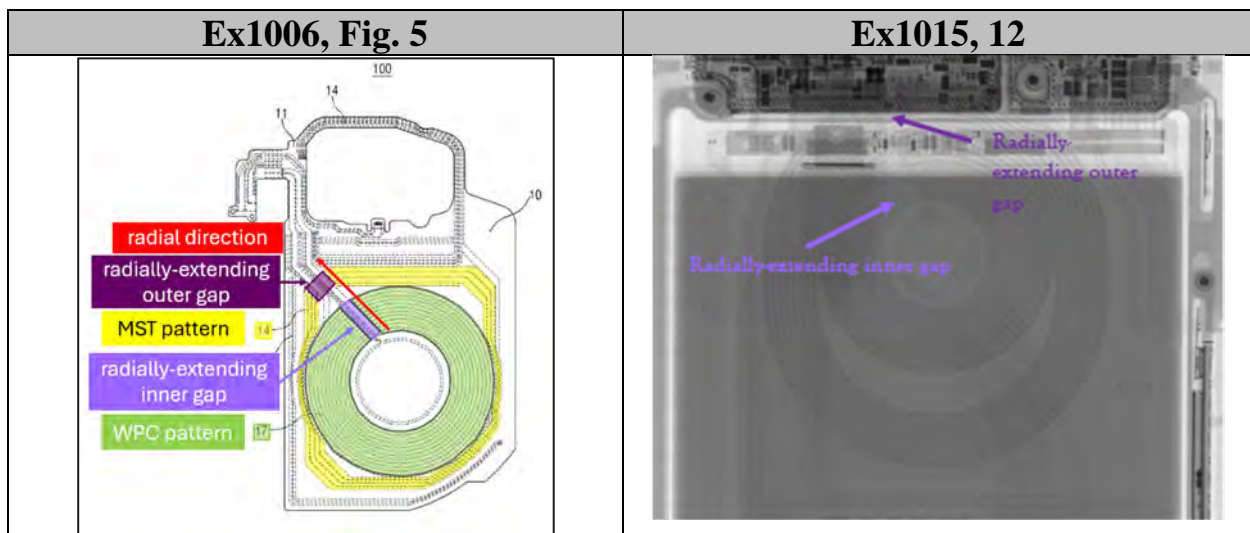

In addition, if PO argues Seong does not teach this limitation, it is met when

“**MST pattern 14**” on Seong’s “**top surface**” is circular (Ground 1 Limitation [1c]):

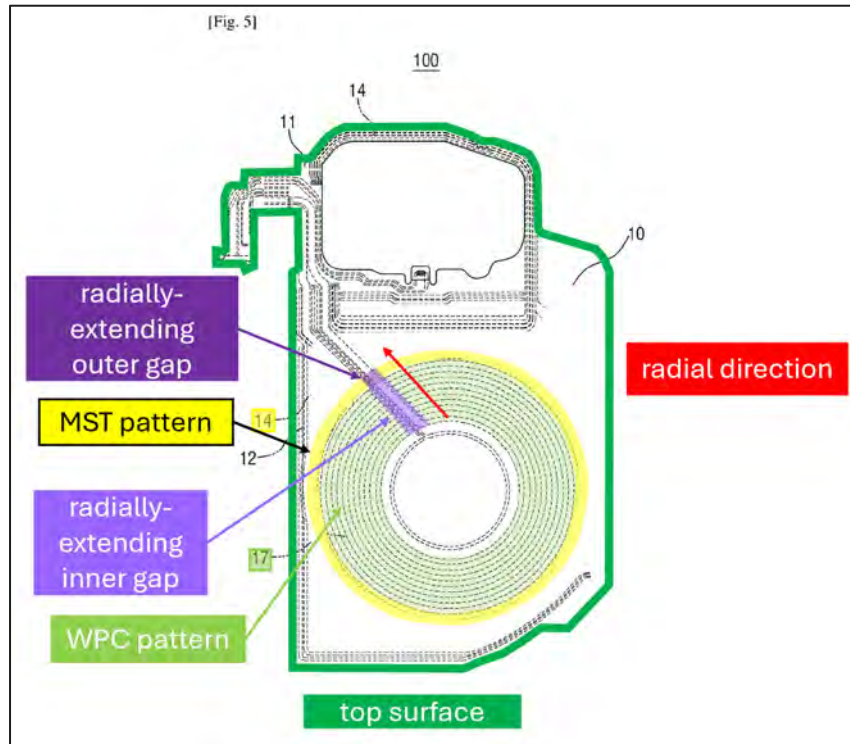

Ex1006, Fig. 5 (modified based on Ex1006 ¶¶63 and Ex1012 ¶¶33, 179, 216, 238, 248-49, Figs. 43, 46, 48-49); Ex1002 ¶141.

In addition, if PO argues a circular “**MST antenna**” in Seong does not teach this limitation either, this arrangement would have been obvious in view of Kang and Cho. Section VIII.A.1; Ex1002 ¶¶142-146.

Kang teaches multiple ways of connecting and aligning radially-extending inner and outer gaps in a radial direction. Kang Figure 49 teaches the **radially-extending outer gap** on Kang’s “**second coil antenna**” and the **radially-extending**

**inner gap** on Kang's "**first coil antenna**" are connected and aligned in a **radial direction**:

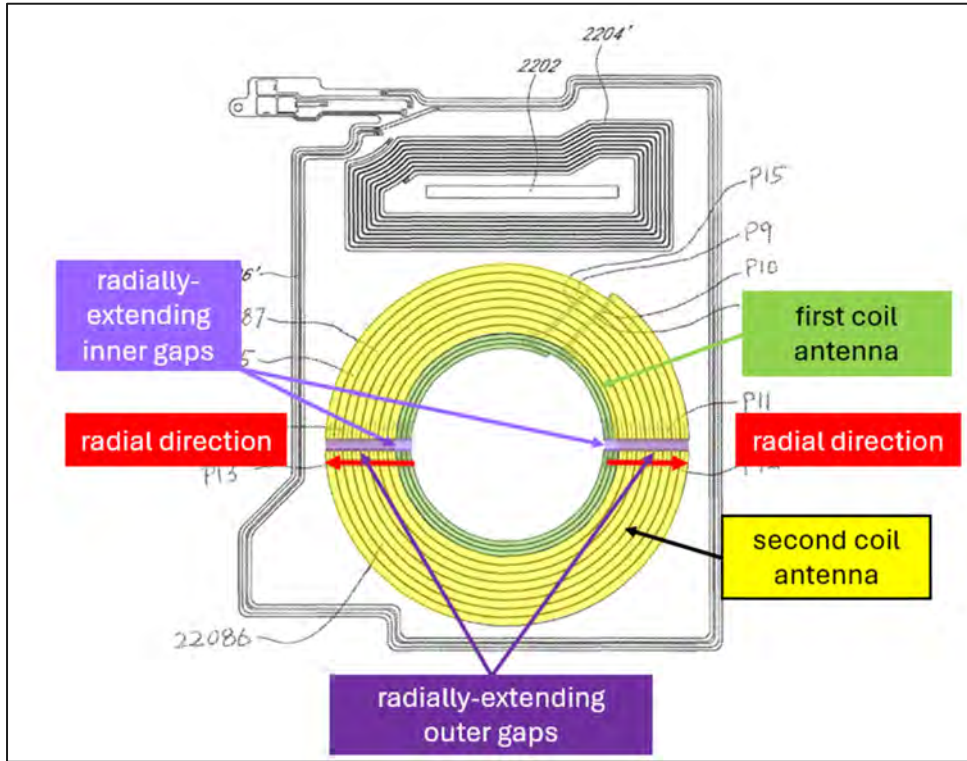

Ex1012, Fig. 49; Ex1002 ¶143.

Kang Figure 48 teaches this too:

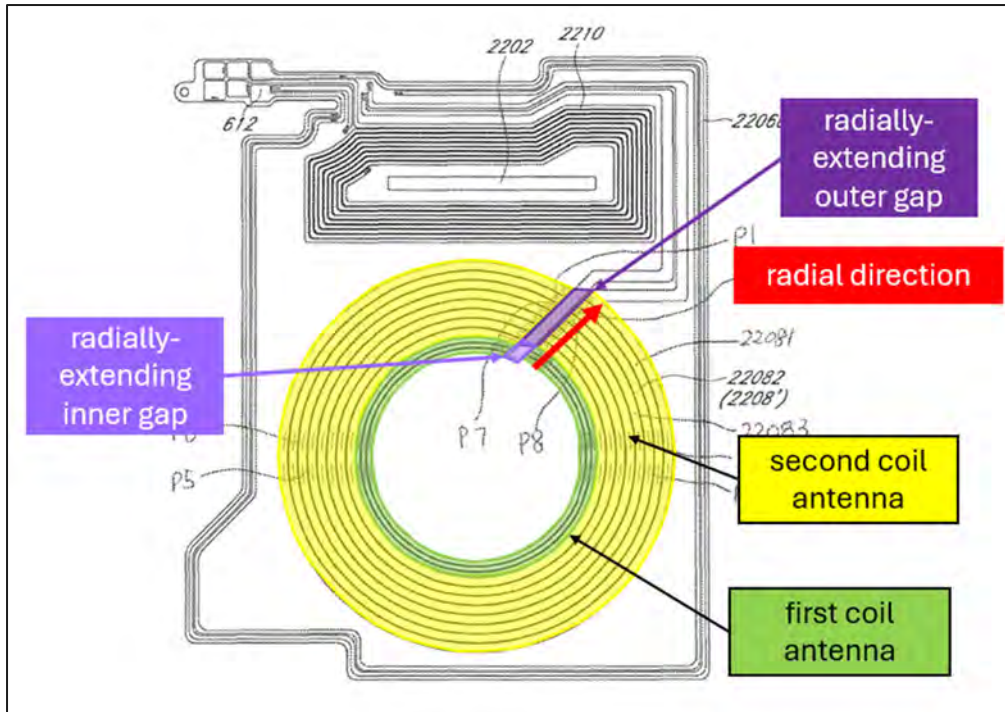

Ex1012, Fig. 48; Ex1002 ¶144.

If PO incorrectly argues Kang does not teach radially-extending inner and outer gaps that are connected and aligned in a radial direction as described above, this would have been obvious in view of Cho. Ex1002 ¶¶145-146. Cho teaches its radially-extending **outer “hollow space [840]”** in **“second wireless communication coil 151”** is connected and aligned in a **radial direction** with **inner “hollow space [810]”** in **“wireless charging coil 111”**:

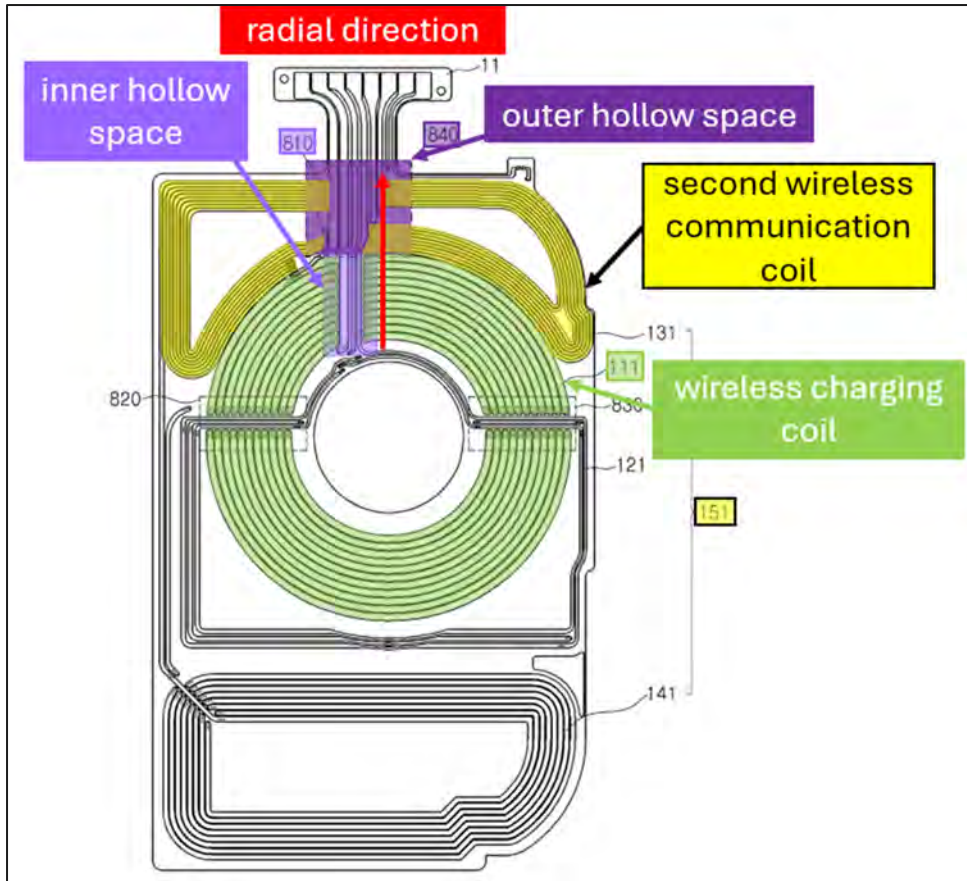

Ex1010 ¶168, Fig. 8; Ex1002 ¶145.

This is at least as much disclosure as PO contends infringes:

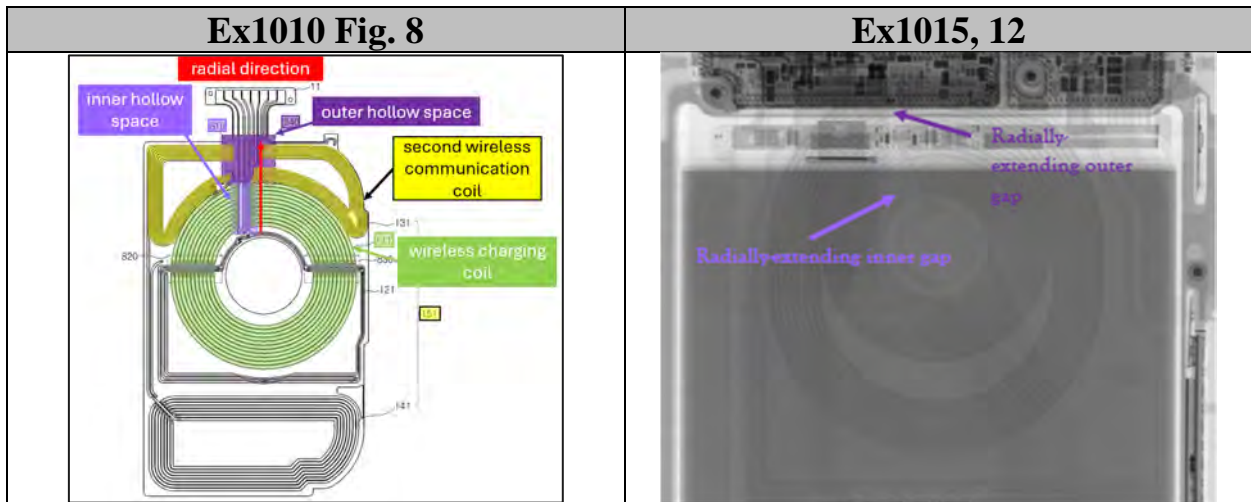

**j. [1i]**

Seong teaches this limitation. Ex1002 ¶¶147-149.

Seong teaches “**an NFC antenna**” and depicts two “**NFC antenna**” extension lines formed on the “**top surface**” that extend along the **radial direction** through both the **radially-extending inner gap** and the **radially-extending outer gap**:

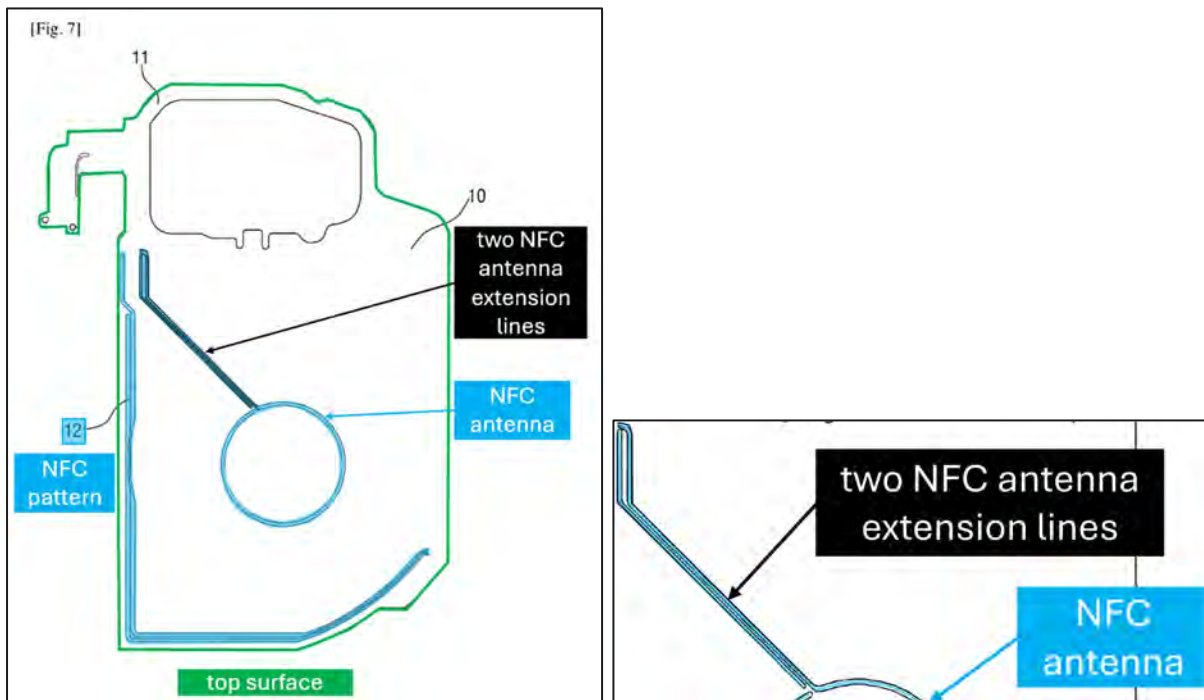

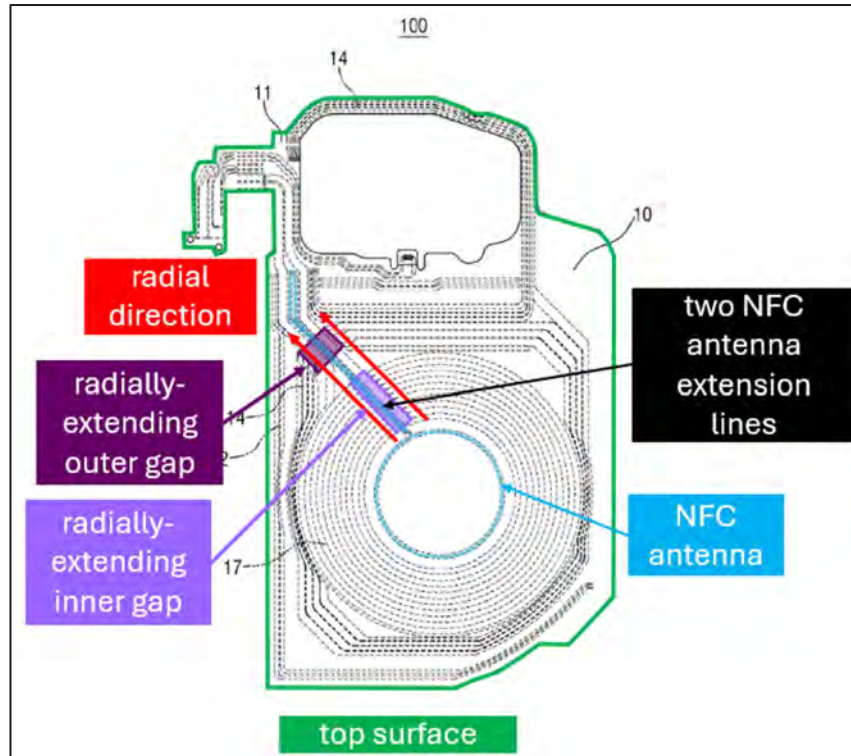

Ex1006, Figs. 5, 7, ¶¶77, 93, Cl. 13; Ex1002 ¶148.

Seong's depicted **NFC antenna** and **NFC antenna extension lines** are essentially identical to those in Figure 48 of the '011 Patent:

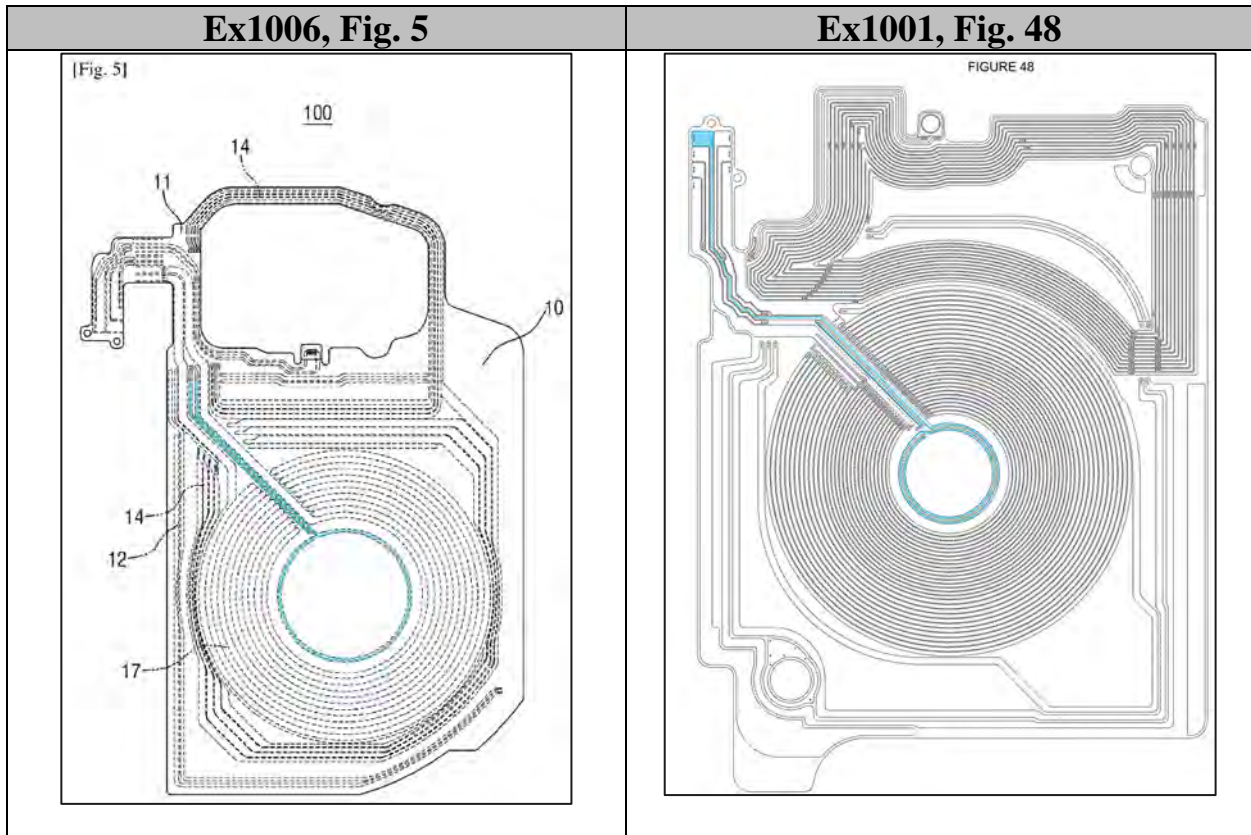

**k. [1j]**

Seong teaches this limitation. Ex1002 ¶¶150-151.

Seong teaches an **inner extension line** formed on the “**top surface**” (second major surface) that extends along the **radial direction** through both the **radially-extending inner gap** and the **radially-extending outer gap**:

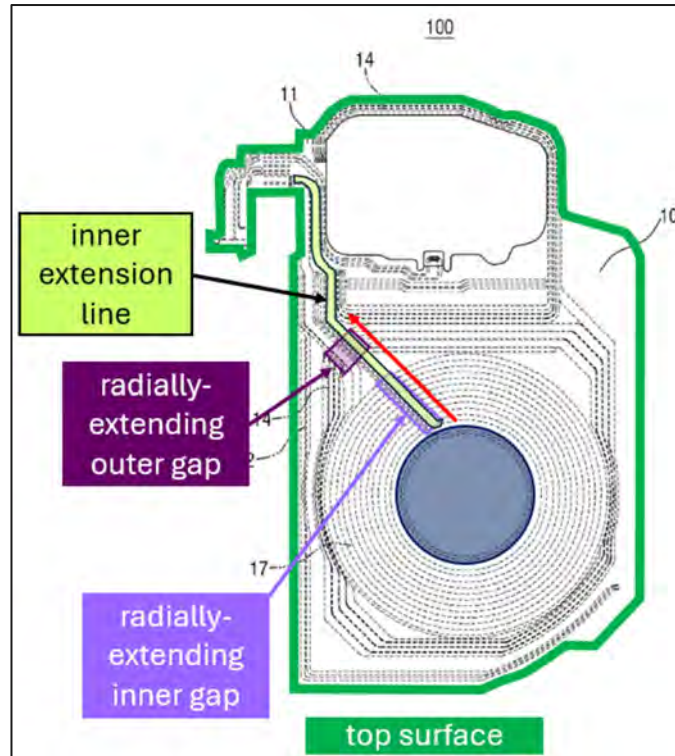

Ex1006, Fig. 5; *id.*, Figs. 11, 12, 15, ¶77 (Seong’s coils, including WPC pattern 17, are connected to “their respective terminals”); Ex1002 ¶151.

**I. [1k]**

Seong teaches this limitation. Ex1002 ¶¶152-154.

Seong teaches an **outer extension line** formed on the “**top surface**” (second major surface) that connects to the “**MST antenna**” and extends along the **radial direction** through the **radially-extending outer gap**:

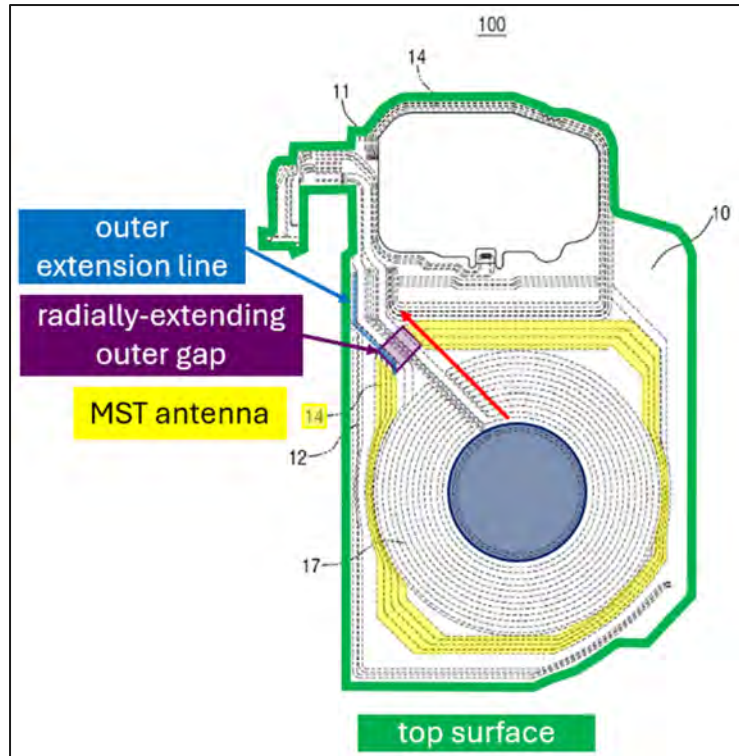

Ex1006, Fig. 5; *id.*, Figs. 9, 15, ¶77 (Seong’s coils, including MST antenna 14, are connected to “their respective terminals”); Ex1002 ¶153.

Seong’s **outer extension line** connects to the “**MST antenna**.” Ex1002 ¶154. “**MST pattern 14** ... may have [its] respective terminal[] ... 16 ... and may be electrically connected with internal components of a mobile communication terminal.” Ex1006 ¶77, Fig. 5.

**m. [1]**

Seong teaches this limitation. Ex1002 ¶¶155-156.

Seong teaches the two “**NFC antenna**” **extension lines**, the **inner extension line**, and the **outer extension line** are extending substantially in parallel:

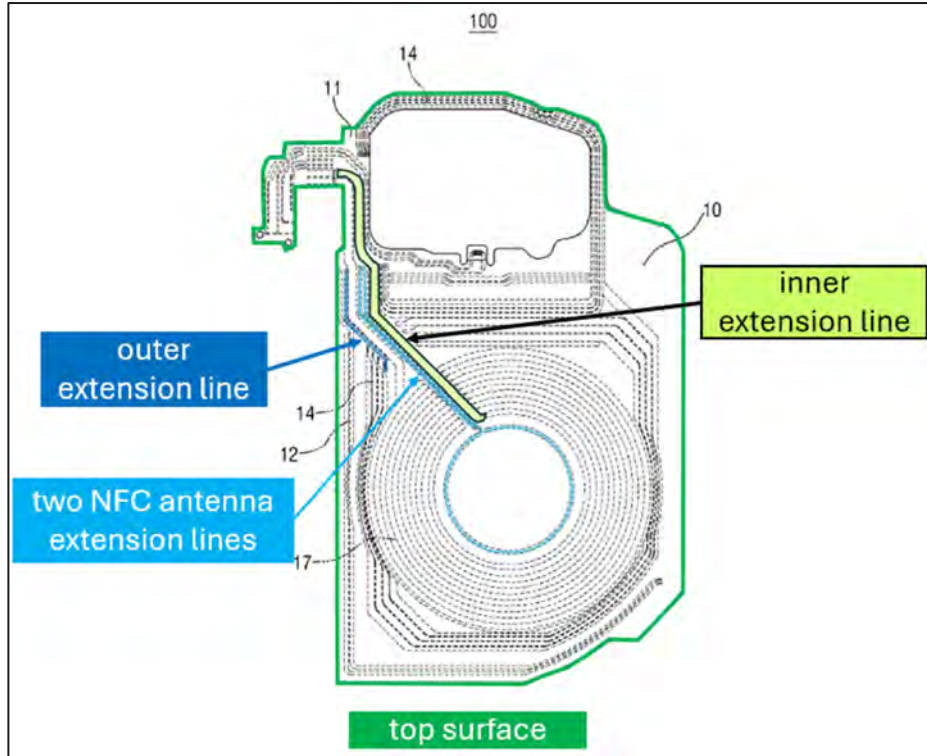

Ex1006, Fig. 5, ¶77; Ex1002 ¶¶156.

This is at least as much disclosure as the '011 Patent:

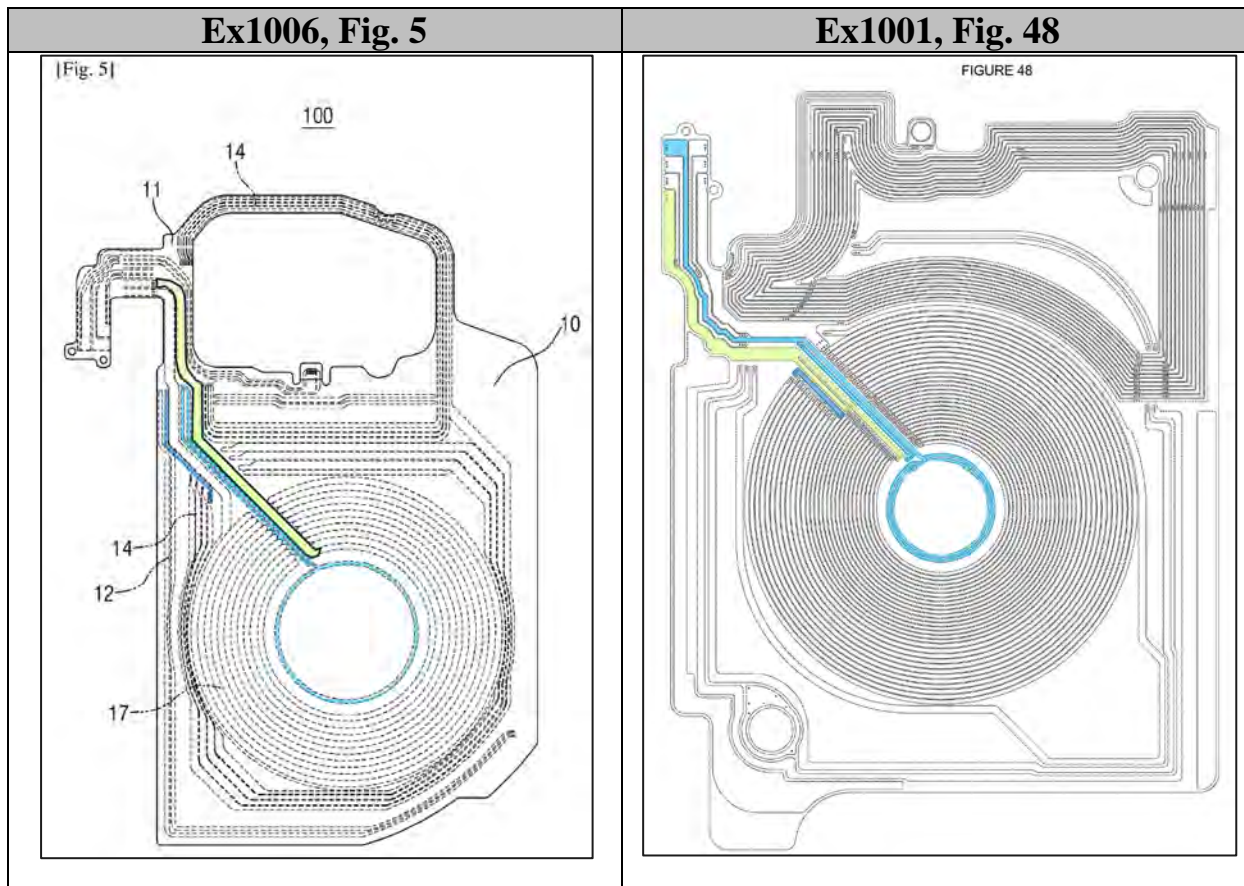

n. [1m]

Seong teaches this limitation. Ex1002 ¶¶157-159.

Seong teaches each of the two “NFC antenna” extension lines, the inner extension line, and the outer extension line formed on the “top surface” (the claimed second major surface) overlaps the “MST antenna” formed on “MST pattern 14” of the “bottom surface” (the claimed first major surface):

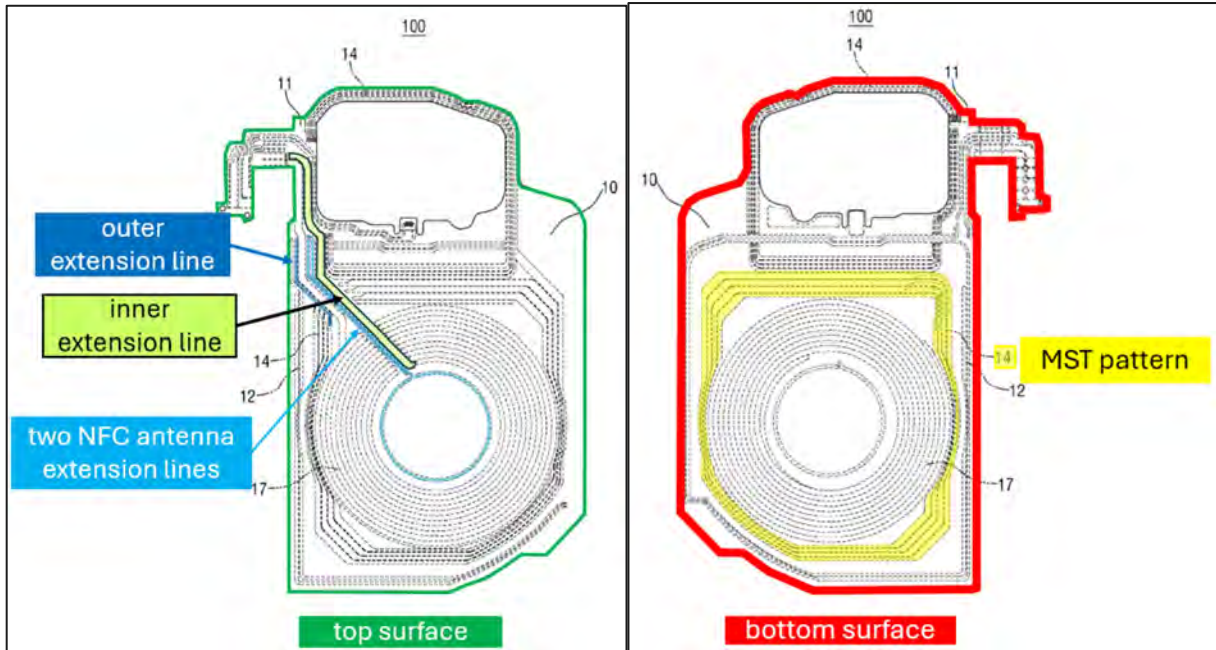

Ex1006, Figs. 5, 6, ¶77; Ex1002 ¶158.

This can be seen by overlaying Seong Figures 5–6:

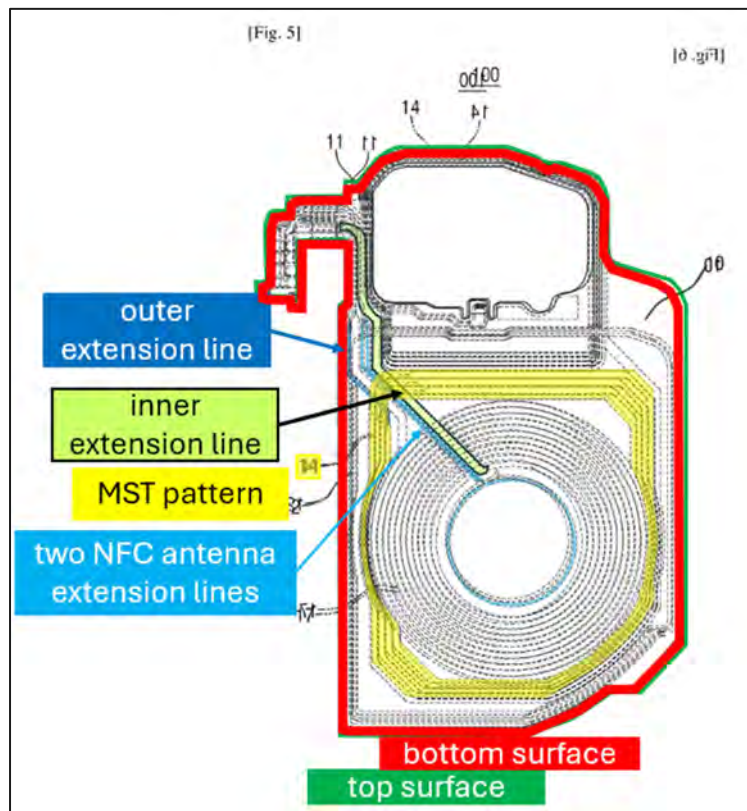

Ex1006, Figs. 5–6 (inverted and combined), ¶77; Ex1002 ¶159.

**o. [1n]**

Seong in view of Kang renders this limitation obvious. Ex1002 ¶¶160-162.

Seong's "MST antenna" and "WPC antenna" "are connected to respective terminals ... 16, and 18." Ex1006 ¶77.

Seong does not, however, teach how the MST and WPC patterns are electrically connected. Kang teaches electrically connecting inner and outer coils in parallel. Ex1012 ¶¶150, 214, 217, 237, Figs. 24A-24B. It would have been obvious to electrically connect Seong's WPC and MST patterns in parallel in view of Kang. Section VIII.A.1; Ex1002 ¶162.

**3. [2]**

The Seong-Kang-Cho combination renders claim 1 obvious and further renders obvious the remaining limitations of this claim. Ex1002 ¶¶163-167.

Seong's coils formed on opposing surfaces of the substrate "are connected to respective terminals" to "be electrically connected to internal [smartphone] components." Ex1006 ¶¶4, 33-34, 77, Figs. 5-6. Seong depicts coils from the same antenna pattern (NFC, WPC, MST) formed on the top and bottom surfaces of the substrate. Ex1006, Figs. 5-8, ¶¶63, 65, 68. A POSA would have understood these coils are interconnected through the PCB using vias. Ex1002 ¶¶164-165.

If PO incorrectly argues Seong does not teach this limitation, it would have been obvious in view of Kang and Cho. Section VIII.A.1; Ex1002 ¶¶166-167. Kang

teaches electrically connecting antenna patterns on different surfaces to each other through a plurality of “vias.” Ex1012 ¶¶76, 231, 247-49, 261, 263, Cl. 6. Cho also teaches electrically connecting antenna patterns on different surfaces to each other through a “plurality of vias.” Ex1010 Cls. 2, 10, ¶¶66-67, 73.

**4. [3]**

The Seong-Kang-Cho combination renders claim 1 obvious and Seong further teaches, or alternatively the combination renders obvious, the remaining limitations of this claim. Ex1002 ¶¶168-170.

Seong’s smartphone antenna module comprises a **first inner extension line**.  
Ground 1 Limitation [1j].

Further, Seong teaches and the Seong-Kang-Cho combination renders obvious, Seong’s smartphone antenna module comprises a second inner extension line formed on the “**top surface**” (second major surface) that connects to the “**WPC antenna**” and extends along the **radial direction** through the **radially-extending outer gap**:

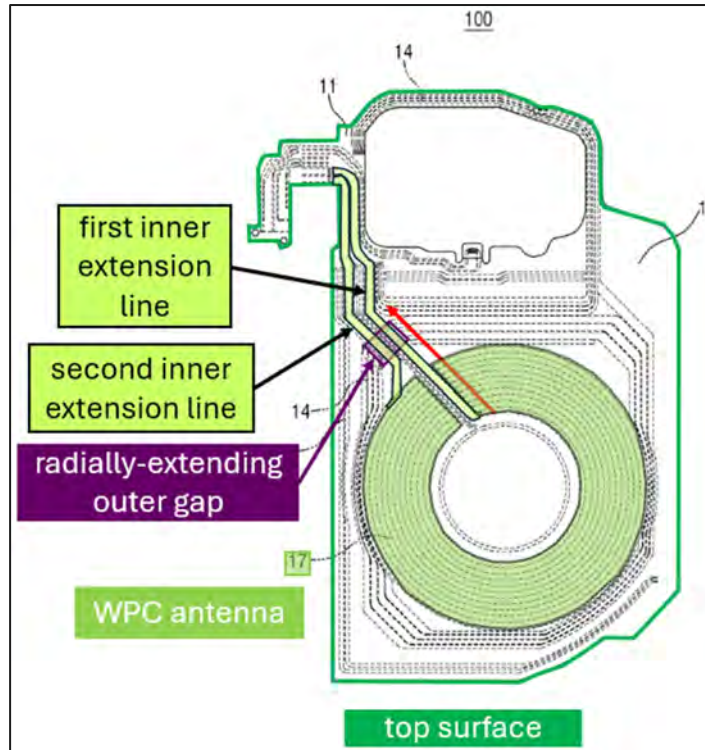

Ex1006, Fig. 5, ¶77; Ex1002 ¶170; Ground 1 Limitations [1g]/[1j].

5. [4]

The Seong-Kang-Cho combination renders claim 1 obvious, Seong further teaches, and the combination renders obvious, the additional limitations of this claim. Ex1002 ¶¶171-173.

Seong’s “**WPC antenna**” includes a wire line having a width different from that of a wire line of the “**MST antenna**”:

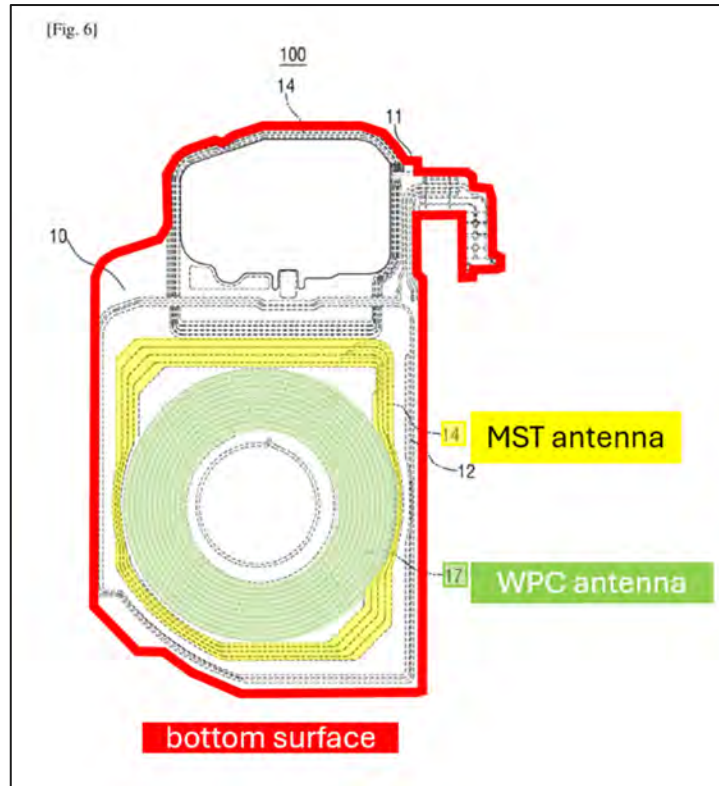

Ex1006, Fig. 6; Ex1002 ¶172.

Seong's coil's wire lines' widths may vary, as Seong Figure 6 depicts.

Ex1006 ¶63; Ex1002 ¶173.

## 6. [5]

The Seong-Kang-Cho combination renders claim 1 obvious and Seong further teaches, or alternatively the combination renders obvious, the additional limitations of this claim. Ex1002 ¶¶174-176.

Seong's "**WPC antenna**" (inner coil) has a first number of turns that is greater than that of "**MST antenna**" (outer coil):

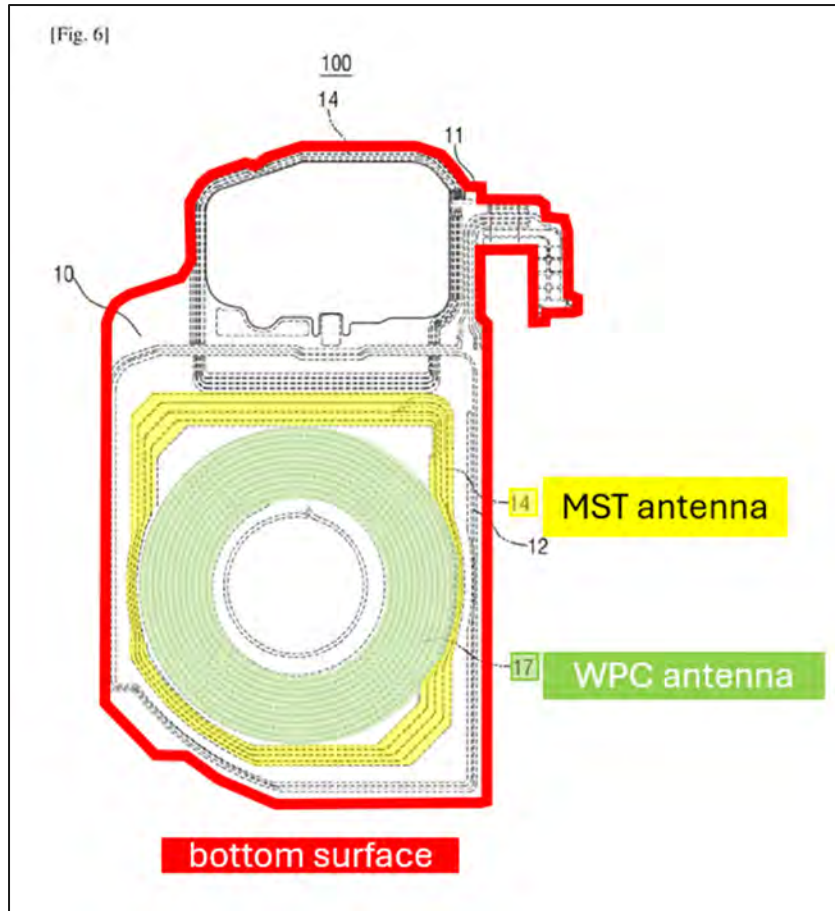

Ex1006, Fig. 6; Ex1002 ¶175.

As shown above, Seong depicts “**WPC antenna**” having approximately 11 turns, and “**MST antenna**” having approximately 4 turns. Ex1002 ¶176. Further, Seong teaches antenna pattern “shape” and “arrangement” “may be varied,” including the number of coil turns. Ex1006 ¶63; Ex1002 ¶176.

7. [6]

The Seong-Kang-Cho combination renders claim 1 obvious and further renders this claim obvious. Ex1002 ¶¶177-181.

Seong teaches a “smartphone[]” comprising a “battery” and an “antenna structure” including coils “provid[ing] ... wireless charging.” Ex1006, Abstract, ¶¶3, 5, 12, 28, 53, 64, 75, 77, 80, Abstract.

Kang teaches configuring the inner and outer coils for wireless battery charging. Ex1002 ¶179. Kang teaches “the third coil antenna is ... configured for wireless charging of the smartphone.” Ex1012 ¶79. Kang also teaches “[t]he second coil antenna may function as another antenna, for example, a wireless power charging antenna.” *Id.*, ¶202; *id.*, ¶¶217, 239, 296 (“two coils among the multiple [can be] electrically connected in the same antenna module”).

A POSA would have been motivated to incorporate Kang’s teachings that the inner and outer coils can be configured for wireless battery charging with Seong to improve Seong’s antenna module’s performance and flexibility. Ex1002 ¶180. This would have been a simple design choice of what functionality to use for which of Seong’s coils. *Id.*

A POSA would have reasonably expected success. Ex1002 ¶181. Seong teaches using its antenna module for wireless charging and teaches “the shape and layout arrangement of the antenna patterns may vary.” Ex1006 ¶63. Kang teaches using coils for various wireless-communication functions: “[e]ach coil can be used as one of an MST antenna, an NFC antenna and other antenna that uses a coil antenna, such as wireless charging antenna” and “two coils among the multiple [can

be] electrically connected in the same antenna module.” Ex1012 ¶¶216–17, 238–39, 296.

**B. Ground 2: Ahn Renders Claims 1–6 Obvious In View Of 721Lee**

**1. Motivation To Combine Ahn And 721Lee**

Ahn and 721Lee overcome limited space in smartphones with space-efficient WPC, NFC, and MST antennas, optimizing shape and layout, placing coils on both sides of a substrate. Section V. A POSA reading Ahn would have been motivated to incorporate 721Lee’s teachings. Ex1002 ¶¶182-186. Both references teach antenna patterns on both sides of a substrate in a smartphone, including WPC, NFC, and MST antennas. Ex1007, ¶¶113, 120, Figs. 3–4, 6–9; Ex1011, Figs. 10A–B; Ex1002 ¶182. If Ahn is found to not expressly teach a claimed limitation, as discussed below, it would have been obvious to a POSA to adopt well-known, predictable, and finite approaches taught by 721Lee to Ahn to achieve wireless communication functions in a space efficient module. Ex1002 ¶182.

Ahn teaches running extension lines through disconnected coil regions to connect second and third coil wirings to connection pads. Ex1007 ¶¶73, 124, Figs. 3-4, 10. If PO disagrees, a POSA would have found this arrangement obvious in view of 721Lee. Ex1002 ¶183.

Lead wirings must “traverse” coil wirings without contacting them, and running lead wirings through disconnected coil regions was a well-known solution.

Ex1002 ¶184. Reading Ahn, a POSA would have been motivated to look to references including 721Lee furthering the same space-efficient goal for antenna modules. Ex1007, Figs. 3-4, 10; Ex1011, Figs.10B, 14C; Ex1002 ¶184. Ahn and 721Lee teach similar ways of achieving that goal—coils on both sides of a substrate, those coils surrounding each other, and extension lines running to those coils through radially-extending gaps. Ex1007, ¶¶72-73, 124, Figs. 4, 10; Ex1011, ¶140, Figs. 10B, 14C; Ex1002 ¶184. Further, 721Lee teaches inner and outer gaps (“interval[s]” of inner and outer coils, which “have the opened loop form”) and explains gaps beneficially allow concentric coils to “be connected to input/output terminals” using extension lines:

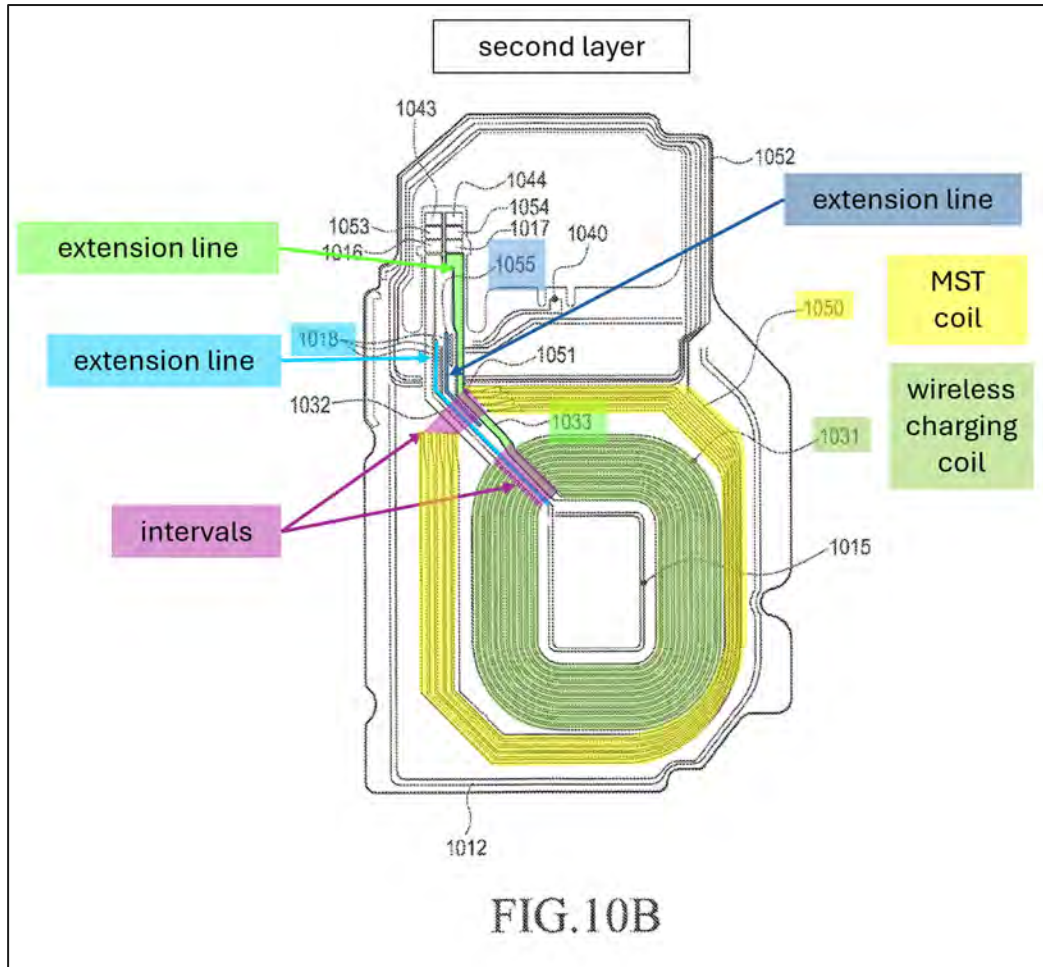

Ex1011 ¶140, Fig. 10B; Ex1002 ¶184.

A POSA would have been motivated to incorporate 721Lee's gaps teachings with Ahn to achieve this benefit and further optimize space-efficiency by running extension lines to concentric coils through gaps. Ex1002 ¶185. Running extension lines through outer coils was known to improve space efficiency by up to 70% (Ex1014 ¶31), including by letting the coils be arranged in a space-efficient, concentric manner, as 721Lee teaches. Ex1011, ¶140, Figs. 10B, 14C; Ex1002 ¶185.

A POSA would have reasonably expected success. Ex1002 ¶185. Ahn uses an extension line traversing a radially-extending inner gap to connect the inner

antenna coil to the external connection pad and explains the second and third coils also need to connect to the connection pad. Ex1007, ¶¶77, 124. Ahn teaches various antenna shapes and layouts are possible. Ex1007, ¶¶111, 126. Running other extension lines through antenna coil gaps would have been a straightforward implementation of a known antenna-pattern layout to achieve predictable results of a space-efficient operable antenna. Ex1002 ¶185.

2. [1]

a. [1pre]

To the extent the preamble is limiting, Ahn teaches it. Ex1002 ¶¶187-189.

Ahn teaches a smartphone “antenna” “coil assembly”:

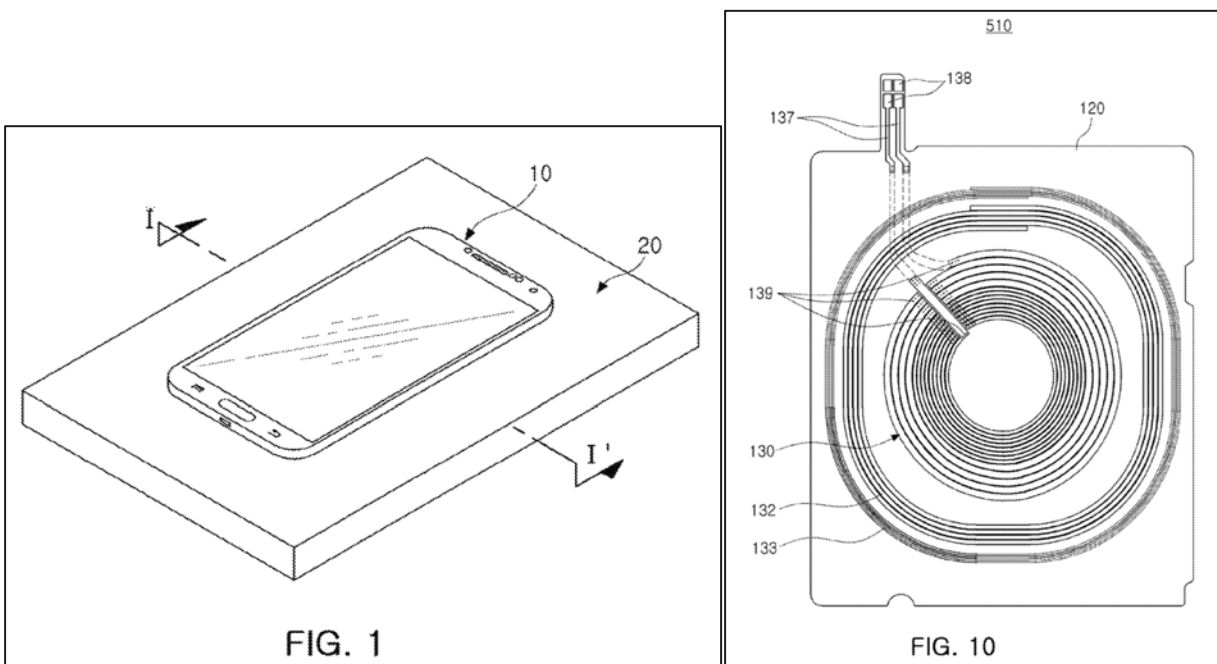

Ex1007, Abstract, ¶¶23, 47–48, 125, Cl. 18, Figs. 1, 10.

This is a smartphone antenna module at least because it comprises multiple antennas. Ex1002 ¶189.

**b. [1a]**

Ahn teaches this limitation. Ex1002 ¶¶190-193.

In Ahn, “substrate 120” has “second surface 120b” (the claimed first major surface) and “first surface 120a” (the claimed second major surface). Ex1007 ¶71, Figs. 3–4. Ahn’s “first surface 120a” and “second surface 120b” face away from each other—they are “opposite surfaces of the substrate”:

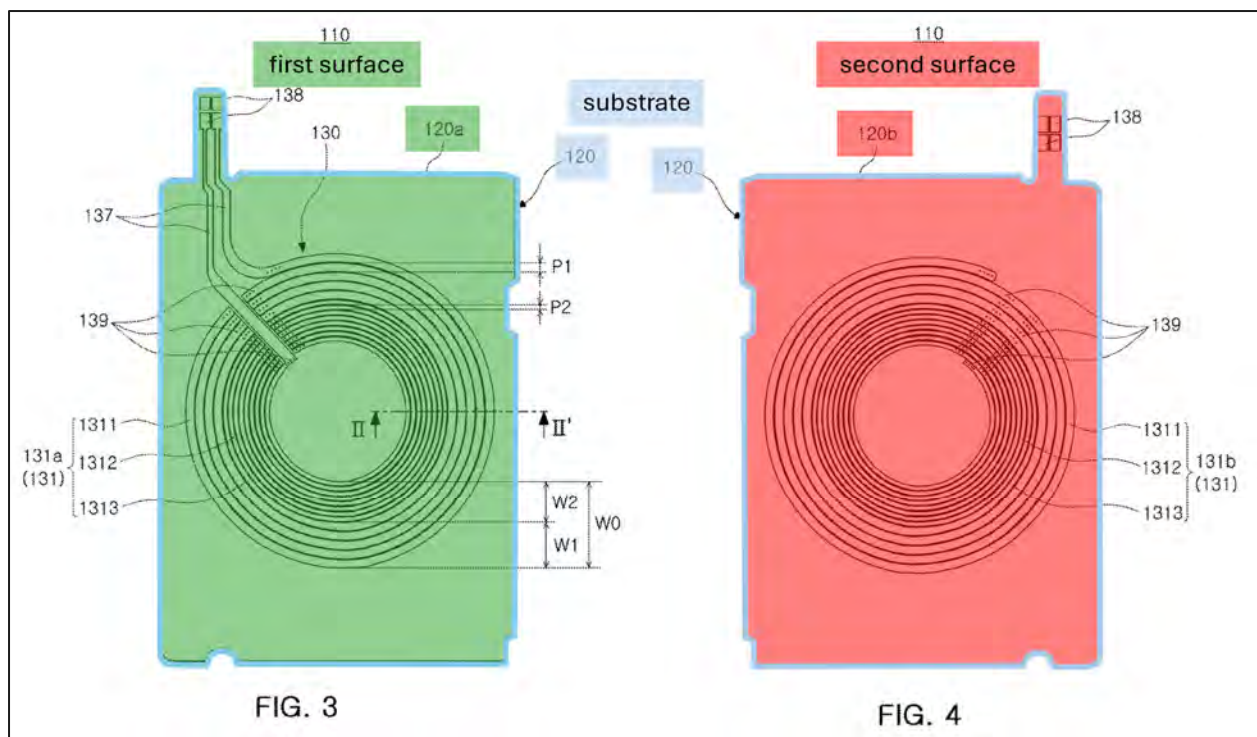

Ex1007 ¶¶27–28, 71, Figs. 3–4; Ex1002 ¶191.

Ahn Figure 10 also depicts the “first surface” of “substrate 120”:

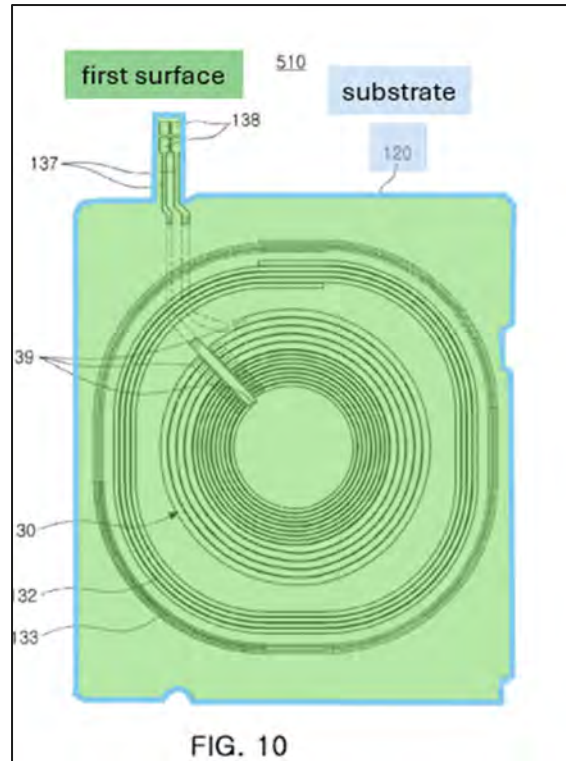

Ex1007, Fig. 10; Ex1002 ¶192.

Figure 10's "**substrate 120**" has opposing surfaces. Ex1002 ¶193. Ahn describes "**substrate 120**," which Ahn depicts in Figure 10, as having a "**first surface 120a**" and a "**second surface 120b**." Ex1007 ¶¶27–28, 71, 107, 113, 120.

c. [1b]

Ahn teaches this limitation or alternatively, the Ahn-721Lee combination renders it obvious. Ex1002 ¶¶194-201.

In Ahn, "**second surface 120b**" (first major surface) comprises a **first central portion**, an area covered by "**second section 1312**" (first inner ring portion) surrounding the **first central portion**, and an area covered by "**first section 1311**" (first outer ring portion) surrounding the area under "**second section 1312**":

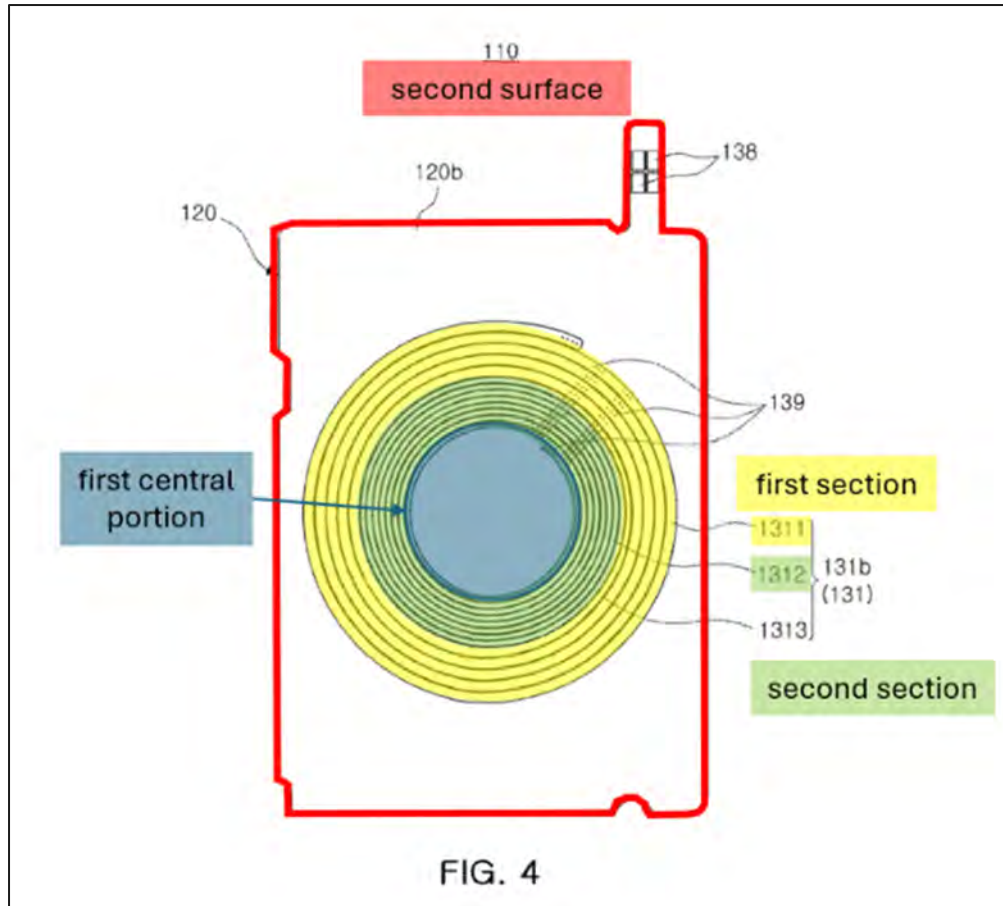

Ex1007 ¶76, Fig. 4; Ex1002 ¶195.

This is at least as much disclosure as what PO accuses of infringing:

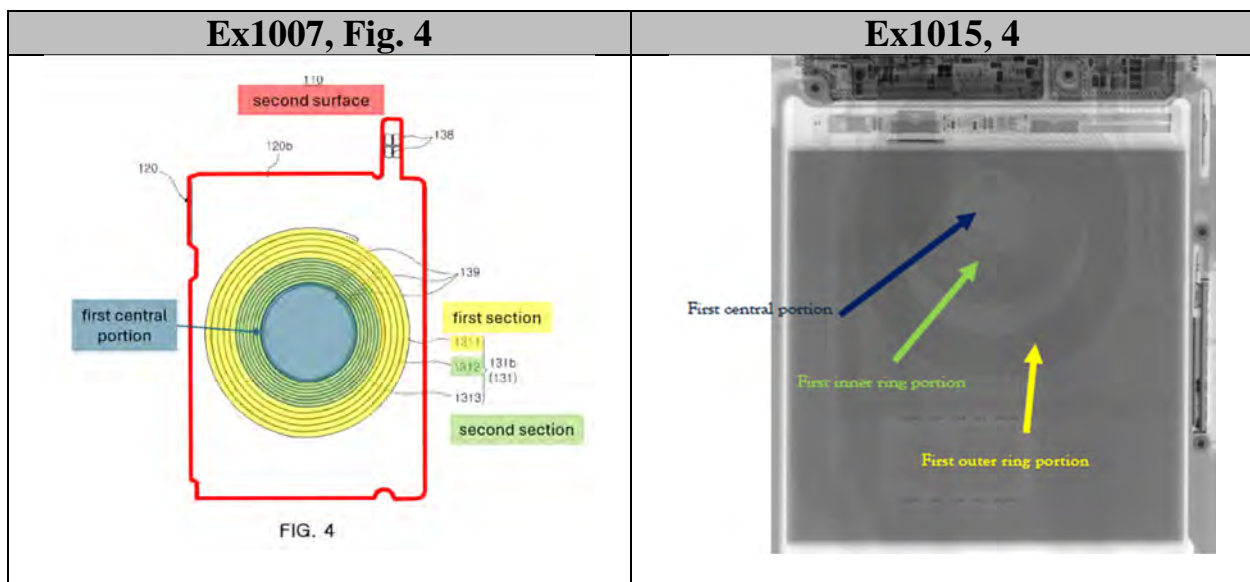

Ahn teaches antenna patterns from Figures 4 and 10 may be disposed on opposing surfaces of “**substrate 120.**” Ex1007 ¶¶122-23 (antenna patterns for Figure 10’s “**substrate 120**” “may have the same structure described ... [for] FIG. 3,” i.e., coils on opposing surfaces, as Figures 3-4 depict), Figs. 3–4; Ex1002 ¶197.

In addition, a POSA would have found using Figure 4’s coil patterns on the back surface of Figure 10’s “**substrate 120**” obvious. Ex1002 ¶198. Ahn teaches combining “coil wiring ... structure[s]” of Figures 10 and 3. Ex1007 ¶¶122-23. Ahn illustrates Figure 10 with “**interlayer connection conductors 139,**” which electrically connect coils on opposing surfaces of “**substrate 120.**” Ex1007 ¶74, Fig. 10. A POSA would have been motivated to look at other Ahn embodiments, including Figures 3–4, illustrating coil patterns on both surfaces. Ex1007, Figs. 3–4, ¶¶113, 120 (describing same for Figs. 8-9), Figs. 6–9; Ex1002 ¶199. Because Ahn teaches Figures 3 and 10 may have “the same structure,” a POSA would have tried combining the embodiments of Figures 4 (Figure 3’s opposing side) and 10. Ex1002 ¶199. Ahn teaches that “features of the examples described [in the specification] may be combined in various ways.” Ex1007 ¶45. A POSA would have reasonably expected success combining Ahn Figures 10 and 4 because it would have been a straightforward application of known coil structures taught by Ahn and because Ahn teaches its “components” can be “combined in a different manner,” “replaced,” or “supplemented.” Ex1007 ¶129.

In addition, if PO incorrectly argues Ahn does not teach forming the antenna patterns from Figures 4 and 10 on opposing surfaces of “**substrate 120**,” this would have been obvious in view of 721Lee. Ex1002 ¶200. 721Lee teaches forming antenna patterns on multiple surfaces, each comprising a **central portion**, an **inner ring portion**, and an **outer ring portion**:

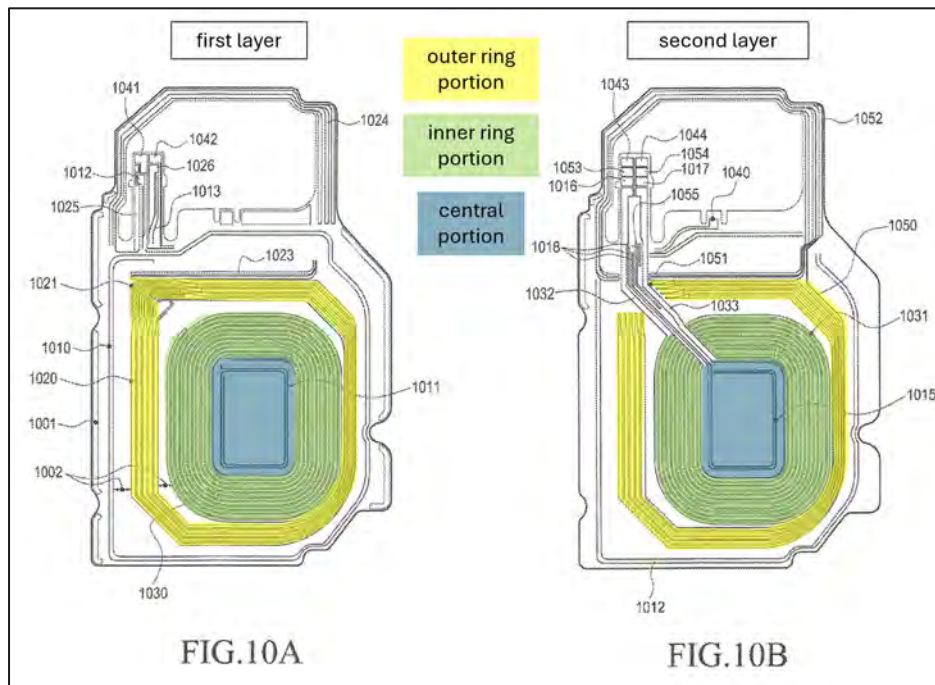

721Lee, Figs. 10A-B; Ex1002 ¶200.

A POSA would have been motivated to incorporate 721Lee’s teaching of forming antenna patterns on multiple surfaces with Ahn because Ahn already teaches this with several embodiments. Ahn, ¶¶113, 120, Figs. 3-4, 6-9; Ex1002 ¶201. Further, combining Ahn’s Figures 4 and 10 on opposing surfaces of “**substrate 120**” would have been obvious to try in view of 721Lee, and a POSA would reasonably expect success based on the similarities between the antenna

patterns of Ahn’s Figures 4 and 10, and 721Lee’s Figures 10A-B. Section VIII.B.1. Ex1002 ¶201.

**d. [1c]**

Ahn teaches this limitation and the Ahn-721Lee combination renders it obvious. Ex1002 ¶¶202-205.

In Ahn, “**first surface 120**” (second major surface) comprises a **second central portion**, an area occupied by “**first coil wiring 130**” (second inner ring portion) surrounding the **second central portion**, and an area covered by “**second coil wiring 132**” (second outer ring portion) surrounding “**first coil wiring 130**”:

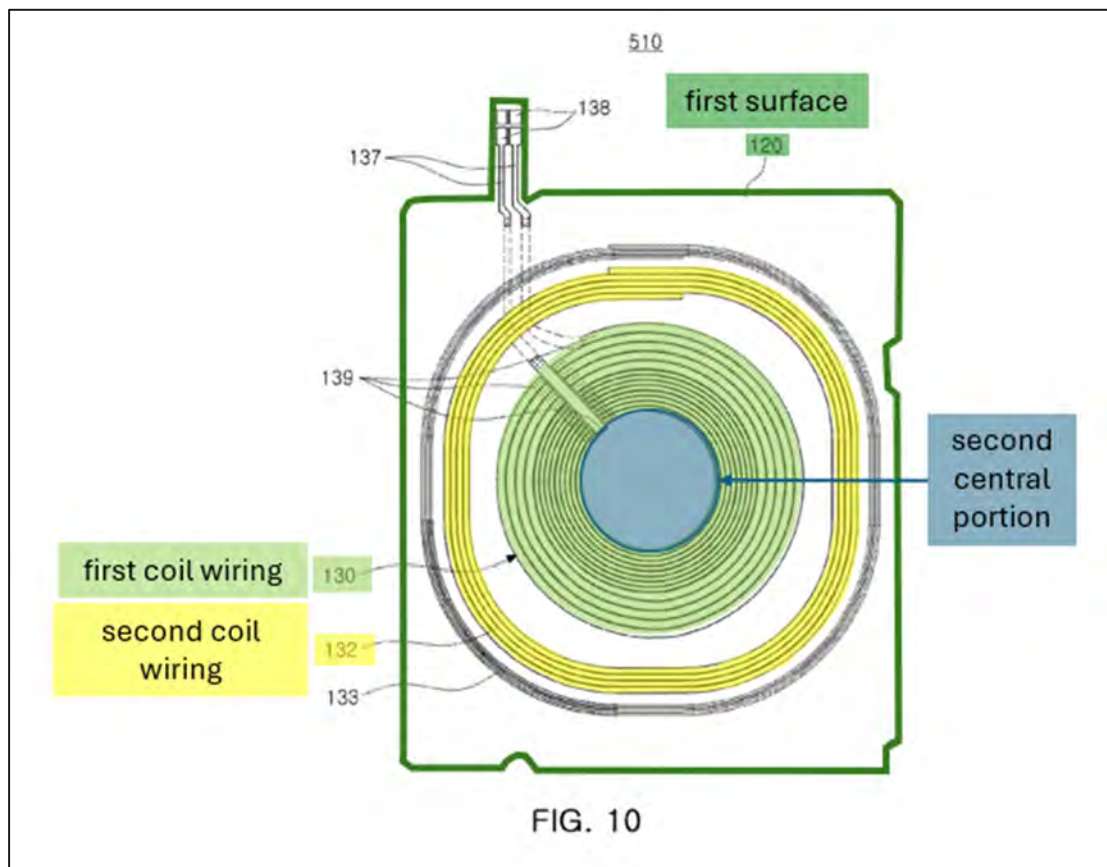

Ex1007 ¶¶122–23, Fig. 10; Ex1002 ¶203.

Ahn teaches and renders obvious forming the antenna patterns from Figures 4 and 10 on opposing surfaces of “**substrate 120.**” Ground 2 Limitation [1b].

Ahn teaches and the Ahn-721Lee combination renders obvious the **second central portion** overlaps the **first central portion**, the area covered by “**first coil wiring 130**” on the “**first surface**” (second major surface) overlaps the area covered by “**second section 1312**” on the “**second surface**” (first major surface) and the area covered by “**second coil wiring 132**” on the “**first surface**” overlaps the area covered by “**first section 1311**” on the “**second surface.**” This can be seen by comparing Ahn’s first and second surfaces:

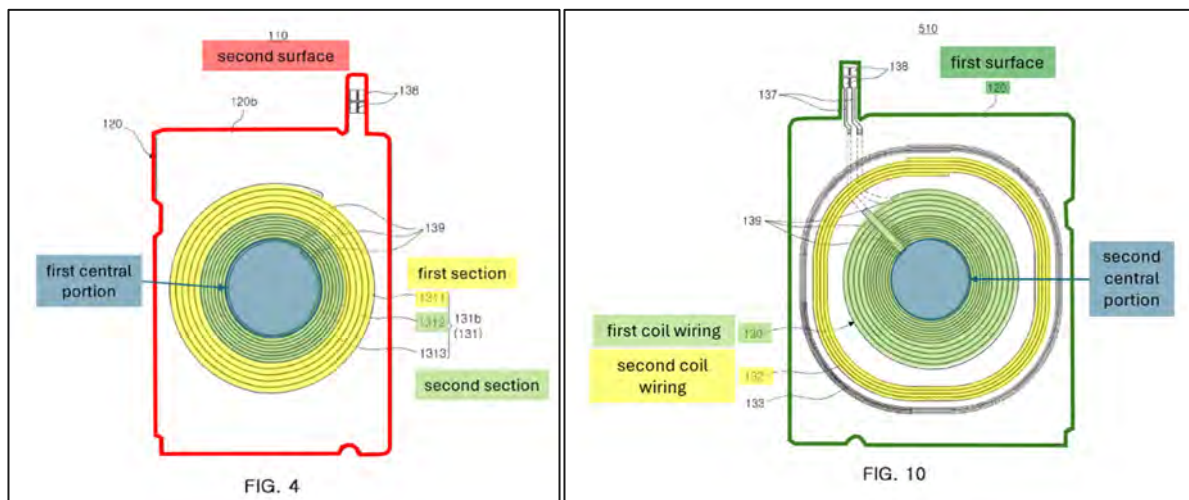

Ex1007, Figs. 4, 10; Section VIII.B.1. Ex1002 ¶205.

**e. [1d]**

Ahn teaches this limitation. Ex1002 ¶¶206-208.

In Ahn, “second spiral wiring 131b” (first antenna pattern) is formed on the “**second surface**” (first major surface) and comprises “**second section 1312**” (inner

coil) formed on the area covered by “second section 1312” and “first section 1311”  
(outer coil) formed on the area covered by “first section 1311”:

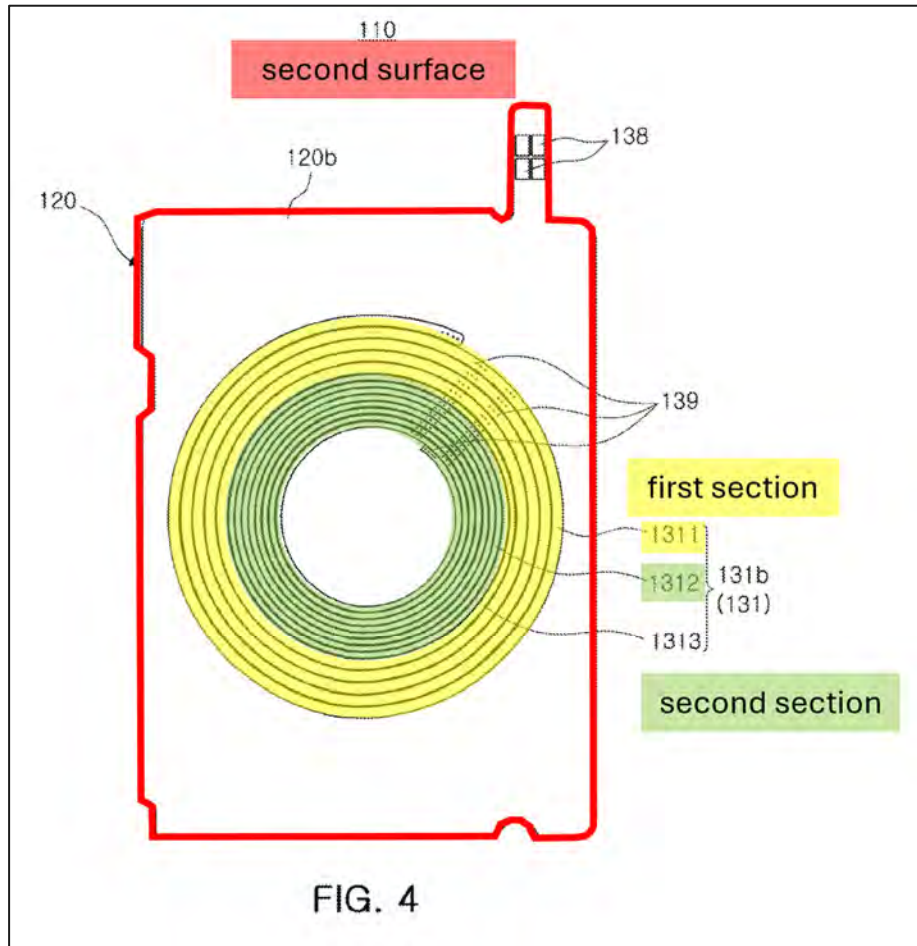

Ex1007 ¶¶71, 76–77, Fig. 4; Ex1002 ¶207.

“[S]econd spiral wiring 131b” comprises coils. Ex1002 ¶208. Ahn describes “second spiral wiring 131b” as a “coil shape” and as a subset of “coil assembly 110.” Ex1007 ¶¶68–69. Ahn’s coil wirings may be used as antennas. Ex1007 ¶125.

**f. [1e]**

Ahn teaches this limitation. Ex1002 ¶¶209-210.

In Ahn, “coil assembly 510” (second antenna pattern) is formed on the “**first surface**” (second major surface) and comprises “**first coil wiring 130**” (inner antenna pattern) formed on the area covered by “**first coil wiring 130,**” “**second coil wiring 132**” (outer antenna pattern) formed on the area covered by “**second coil wiring 132,**” and “**third coil wiring 133,**” which may perform “a near field communications (NFC) function” (NFC antenna pattern), and while Ahn depicts “**third coil wiring 133**” disposed outside of “**second coil wiring 132,**” Ahn expressly teaches “**third coil wiring 133**” “may ... be disposed at the center of the **first coil wiring 130**” (formed on the **second central portion**):

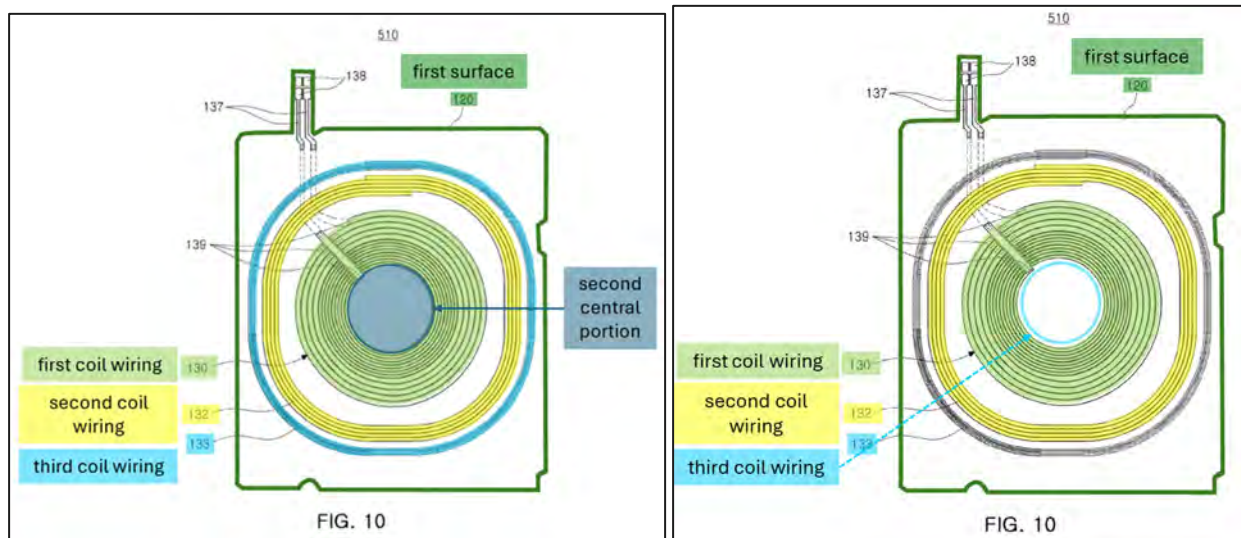

Ex1007 ¶¶71, 123, 125-26, Fig. 10; Fig. 10 (modified per ¶¶71, 123, 125-26);

Ex1002 ¶210.

**g. [1f]**

Ahn teaches this limitation. Ex1002 ¶¶211-214.

Ahn's "**first coil wiring 130**" (inner antenna pattern) comprises a plurality of **concentric C-shaped lines** forming an area where "**first coil wiring 130**" is "**partially disconnected**" (radially-extending inner gap) on the area covered by "**first coil wiring 130**":

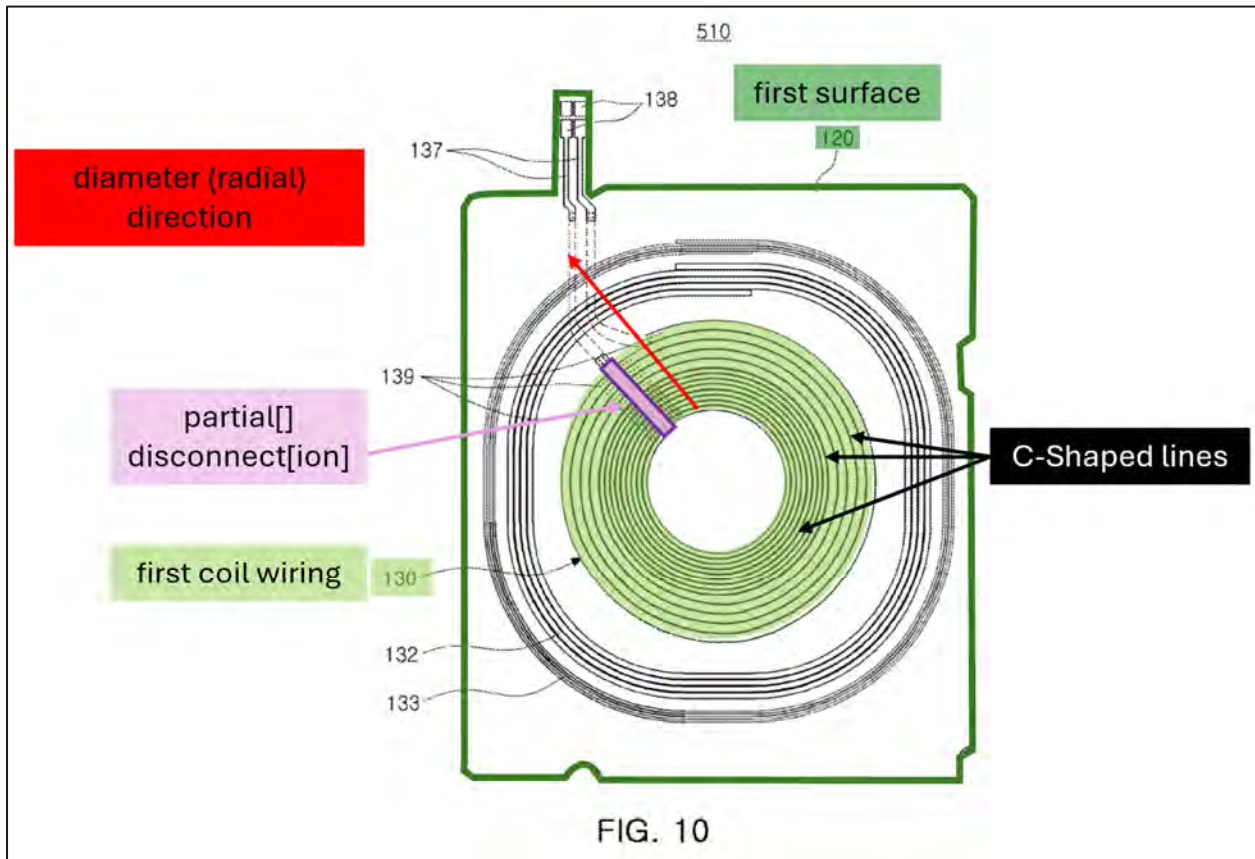

Ex1007 ¶72, Fig. 10; Ex1002 ¶212.

Ahn teaches an inner gap is formed when the spiral wiring of "**first coil wiring 130**" is "**partially disconnected.**" Ex1007 ¶¶72-73, 124-125, Fig. 10. The inner gap's purpose is so "lead wirings 137 may be disposed ... through the disconnected region in a **diameter (radial) direction,**" thereby connecting both ends of "**first coil wiring 130**" to "connection pads 138." Ex1007 ¶73; Ex1002 ¶213.

This is at least as much disclosure as PO contends infringes:

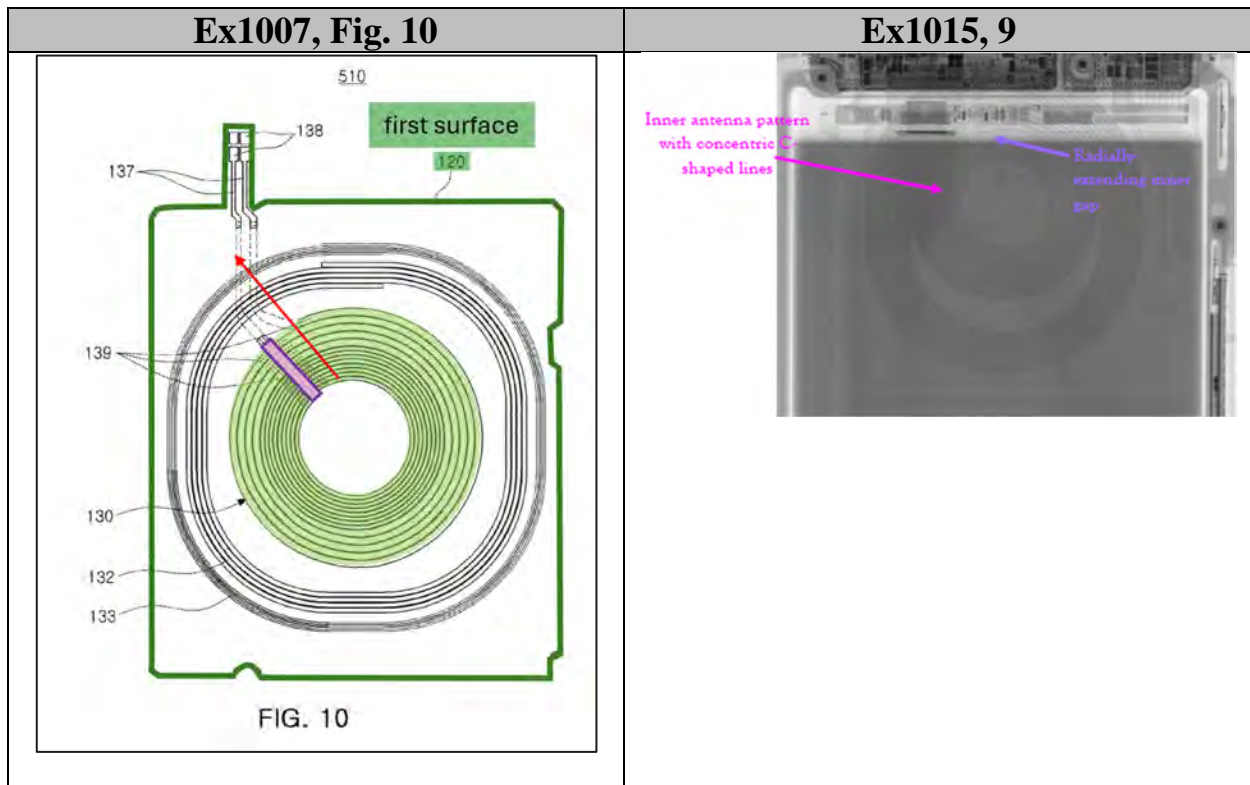

**h. [1g]**

The Ahn-721Lee combination renders this limitation obvious. Ex1002 ¶¶215-220.

Ahn teaches “both ends of the **second wiring coil 132** ... *need* to be connected to the **connection pads 138**, which is *omitted in FIG. 10 for convenience*”:

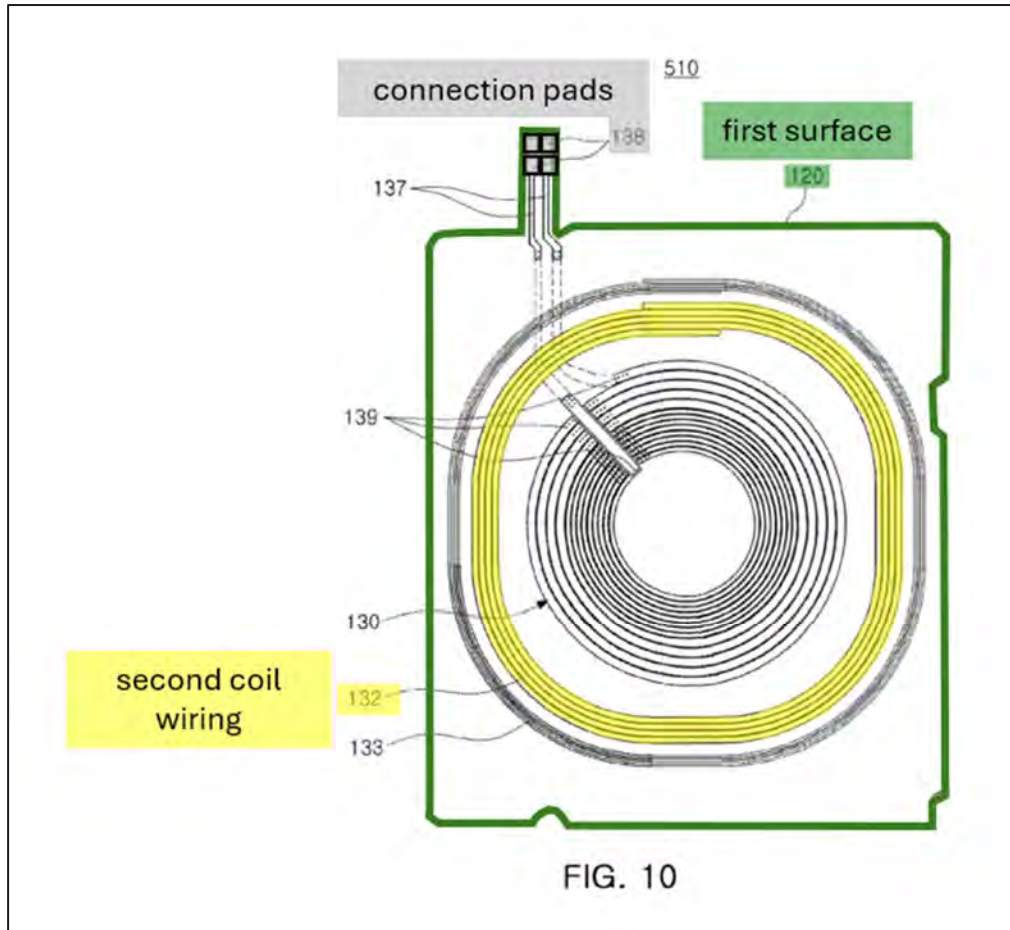

Ex1007 ¶124, Fig. 10; Ex1002 ¶216.

A POSA reading Ahn would have understood, as explained for Ground 2 Limitation [1f] regarding Ahn’s “**partial[] disconnect[ion]**” of “**first coil wiring 130,**” which lets both ends of “**first coil wiring 130**” be connected to connection pads 138 (Ex1007 ¶¶72–73, Fig. 10), Ahn also renders obvious using a **partial disconnection** of “**second coil wiring 132**” (radially-extending outer gap), also formed by concentric C-shaped lines, to effectuate Ahn’s teaching that both ends of “**second coil wiring 132**” are connected to connection pads 138 (*id.* ¶124). Ex1002 ¶217. The **partial disconnection** of “**second coil wiring 132**” allows a space for

the wired connections to “**first coil wiring 130**” because “**first coil wiring 130**” is surrounded by “**second coil wiring 132**”:

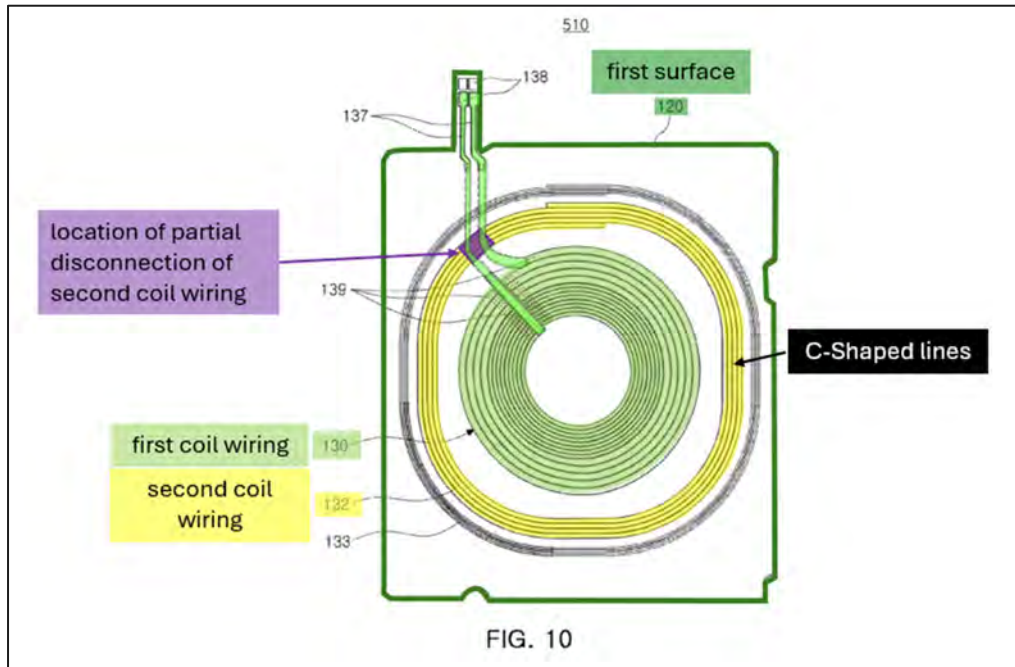

Ex1007, Fig. 10; Ex1002 ¶217.

In addition, this would have been obvious in view of 721Lee. Ex1002 ¶218. 721Lee teaches “**MST coil 1050**” (outer antenna pattern) has an “**interval of the MST coil 1050**” (radially-extending outer gap) through which “**MST patterns 1055**” extend:

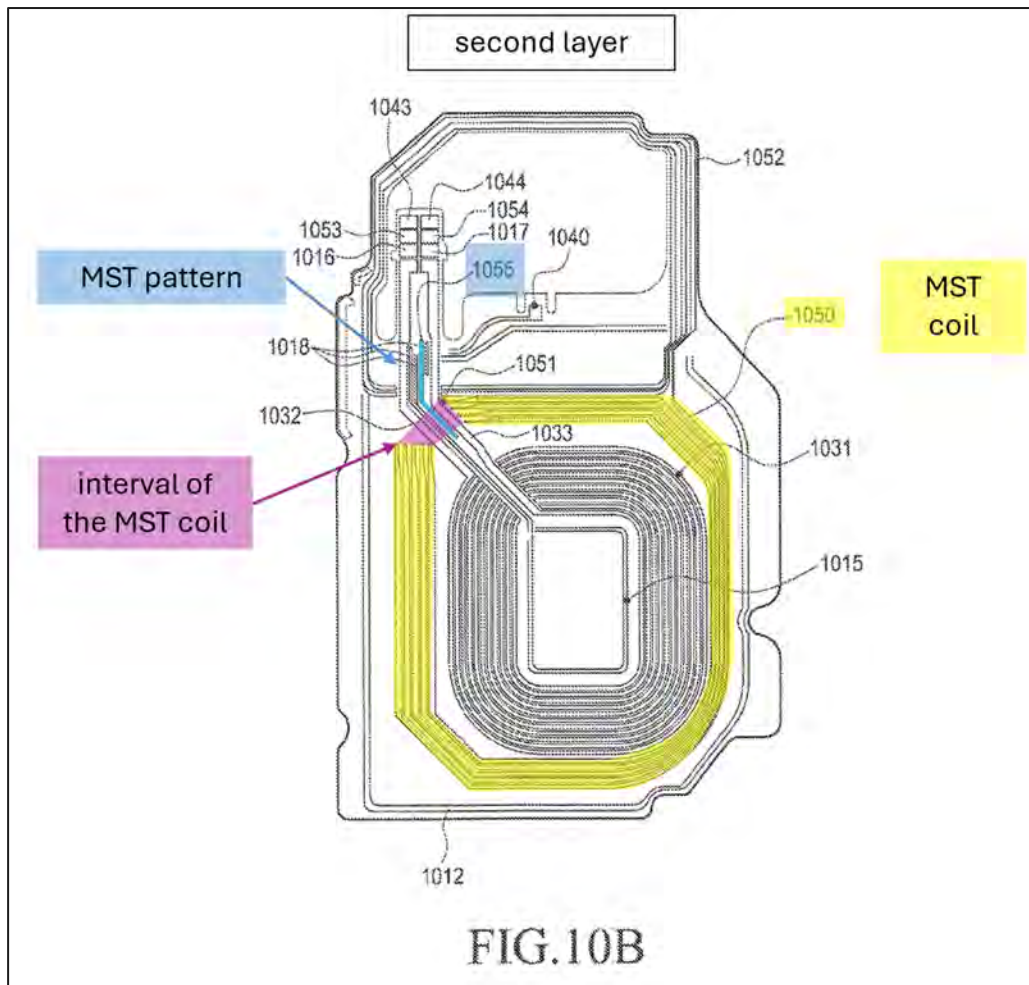

Ex1011 ¶140, Fig. 10B; Ex1002 ¶218.

This outer gap beneficially lets “wireless charging coil 1031” (inner coil) “be connected to the input/output terminals through the interval of the MST coil 1050.”

Ex1011 ¶140.

It would have been obvious to incorporate 721Lee’s radial-gap teachings with Ahn. Section VIII.B.1. The outer antenna pattern of the Ahn-721Lee combination comprises a plurality of concentric C-shaped lines forming a radially-extending

outer gap on Ahn's "second coil wiring 132" for the same reasons as for Ground 2 Limitation [1f]. Ex1002 ¶¶219-220.

**i. [1h]**

The Ahn-721Lee combination renders this limitation obvious. Ex1002 ¶¶221-225.

The Ahn-721Lee combination renders obvious the **partial disconnection** of "second coil wiring 132" and the "partial[] disconnect[ion]" of "first coil wiring 130" are connected and aligned in a "diameter (radial) direction":

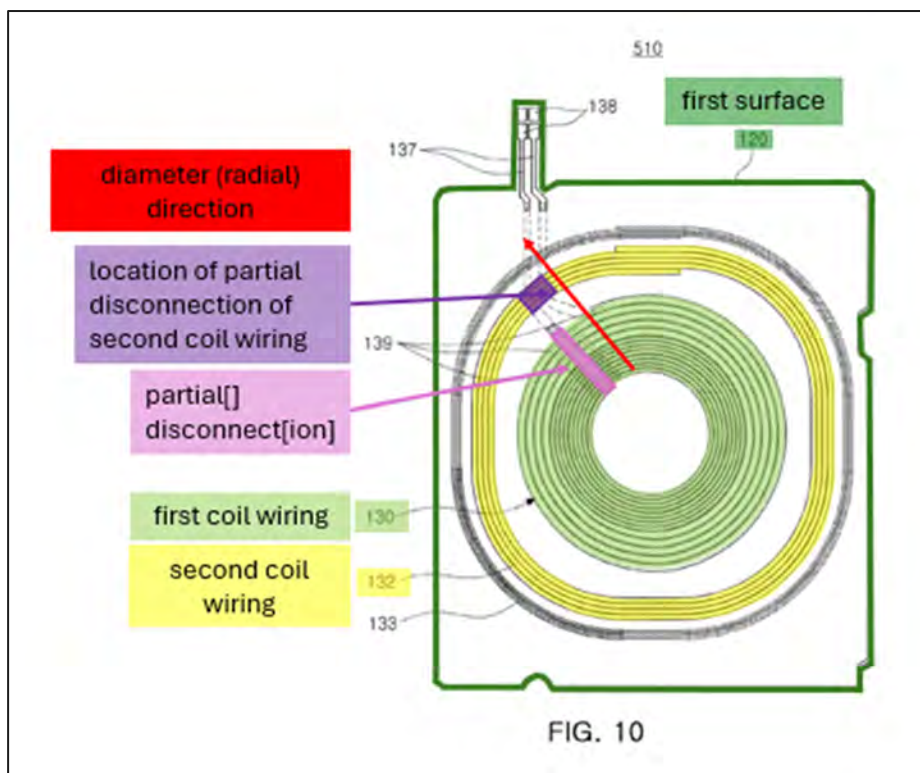

Ex1007, Fig. 10; Ground 2 Limitation [1g]; Ex1002 ¶222.

This is at least as much disclosure as PO contends infringes:

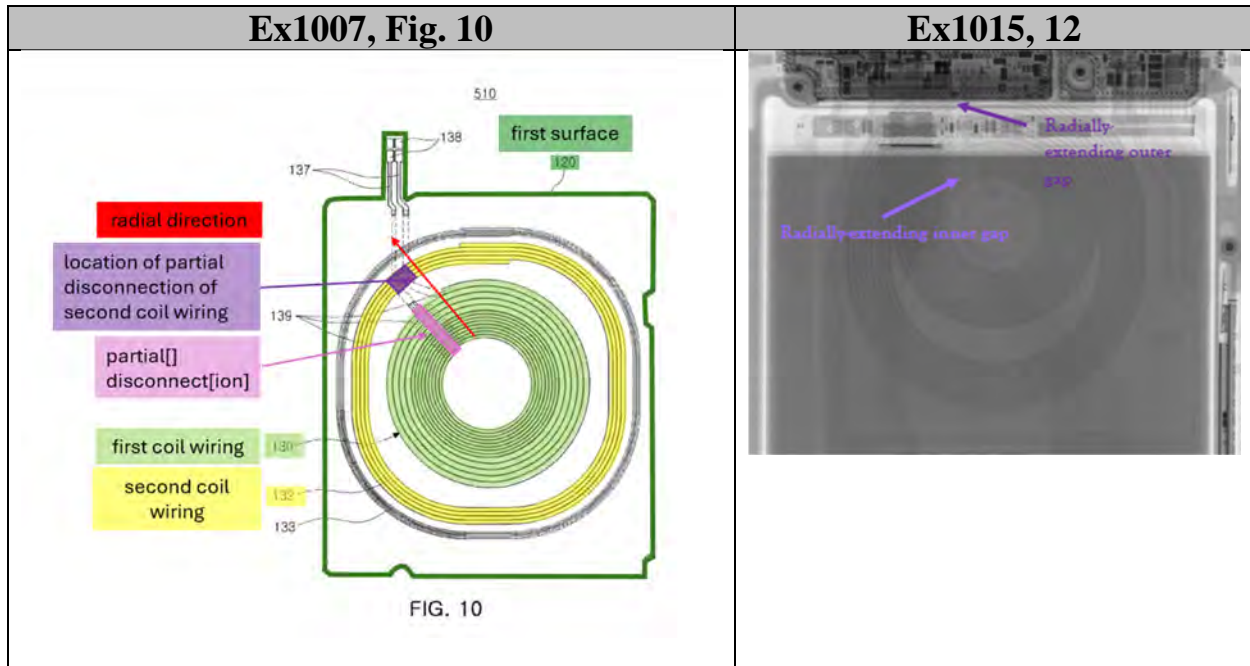

In addition, if PO incorrectly argues that this limitation requires the radially-extending inner and outer gaps be directly adjacent and/or if Ahn’s **partial disconnection** of “**second coil wiring 132**” and the “**partial[] disconnect[ion]**” of “**first coil wiring 130**” are not connected and aligned, a POSA would have found this obvious. Ex1002 ¶224. Ahn teaches “**second coil wiring 132**” and “**first coil wiring 130**” may vary in width, turns, shapes, and configurations. Ex1007 ¶¶44, 77, 105, 126. A POSA would have understood a directly adjacent arrangement was possible and would have been motivated to further Ahn’s space-efficiency goal (Ex1007 ¶¶4, 65, 68) by arranging the inner and outer coils such that their gaps were tightly connected and aligned. Ex1002 ¶224.

Ahn teaches, and further, it would have been obvious, to incorporate Ahn’s Figures 3-4 teachings with Ahn’s Figure 10 teachings. Ground 2 Limitation [1b].

j. [1i]

The Ahn-721Lee combination renders this limitation obvious. Ex1002 ¶¶226-230.

Ahn's "**third coil wiring 133**" may be "disposed at the center of the **first coil wiring 130**" and "both ends" of "**third coil wiring 133**" "*need* to be connected to the **connection pads 138**," Ex1007 ¶¶124, 126; Ground 2 Limitation [1e], which a POSA would have understood is accomplished by running two **NFC antenna extension lines** (one for each end of "**third coil wiring 133**") from "**connection pads 138**" to "**third coil wiring 133**." Ex1002 ¶227. A POSA would have understood the most logical route to map Ahn's two **NFC antenna extension lines** is the same way as Ahn depicts for "lead wirings 137" and "**first coil wiring 130**"—the "**diameter (radial) direction**" through a **partial disconnection** of "**second coil wiring 132**" and the "**partial[] disconnect[i]on**" of "**first coil wiring 130**":

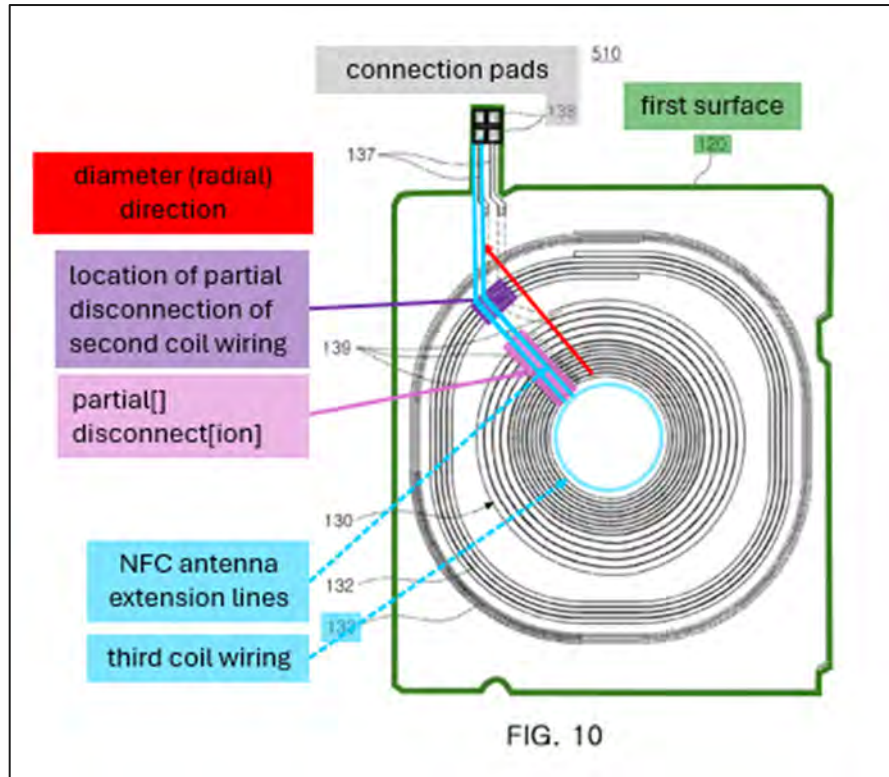

Ex1007, Fig. 10 (modified based on ¶¶124, 126 to illustrate the “**third coil wiring 133**” and its two **NFC antenna extension lines**); Ex1002 ¶227.

In addition, this limitation would have been obvious in view 721Lee. Ex1002 ¶¶228-230.

721Lee teaches “**NFC pattern 1018**” (NFC antenna extension lines) is connected to the “**NFC coil 1015**” and traverses the “**interval of the MST coil 1050**”:

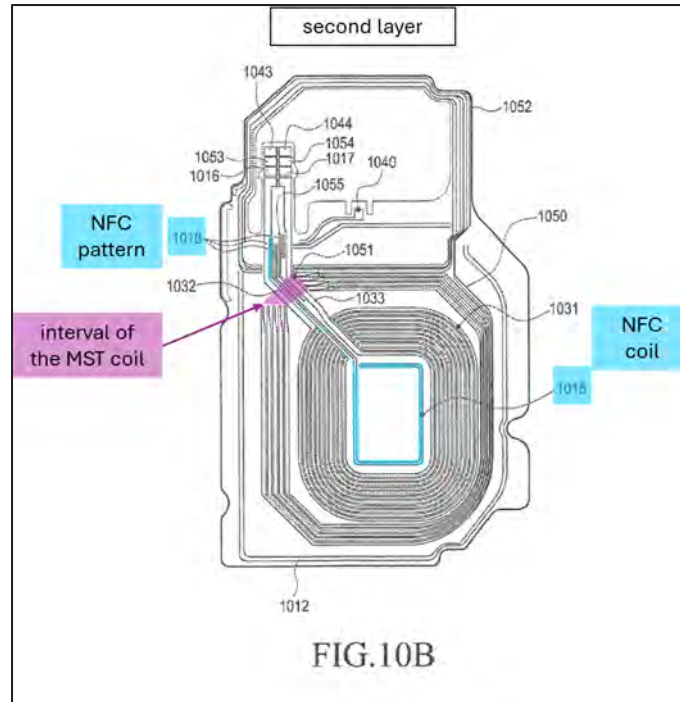

Ex1011 ¶142, Fig. 10B; Ex1002 ¶229.

It would have been obvious to incorporate 721Lee’s radially-extending gap teachings with Ahn. Section VIII.B.1. In the Ahn-721Lee combination, the two NFC extension lines formed on Ahn’s “**first surface**” (second major surface) extend along the “**diameter (radial) direction**” through both a **partial disconnection** of “**second coil wiring 132**” and the “**partial[] disconnect[ion]**” of “**first coil wiring 130.**” Ground 2 Limitation [1g]; Ex1002 ¶230.

**k. [1j]**

The Ahn-721Lee combination renders this limitation obvious. Ex1002 ¶¶231-233.

Ahn’s “**lead wirings 137**” “connect[] one end of the first spiral wiring 131a disposed at the center (e.g., the innermost turn) of the first spiral wiring 131a and

one of the connection pads 138 to each other” (i.e., an inner extension line formed on Ahn’s “**first surface**” (second major surface)), and “**lead wirings 137**” “traverse the spiral wiring 131a through the **disconnected region** in a **diameter (radial) direction** of the [first] spiral wiring [131a]”:

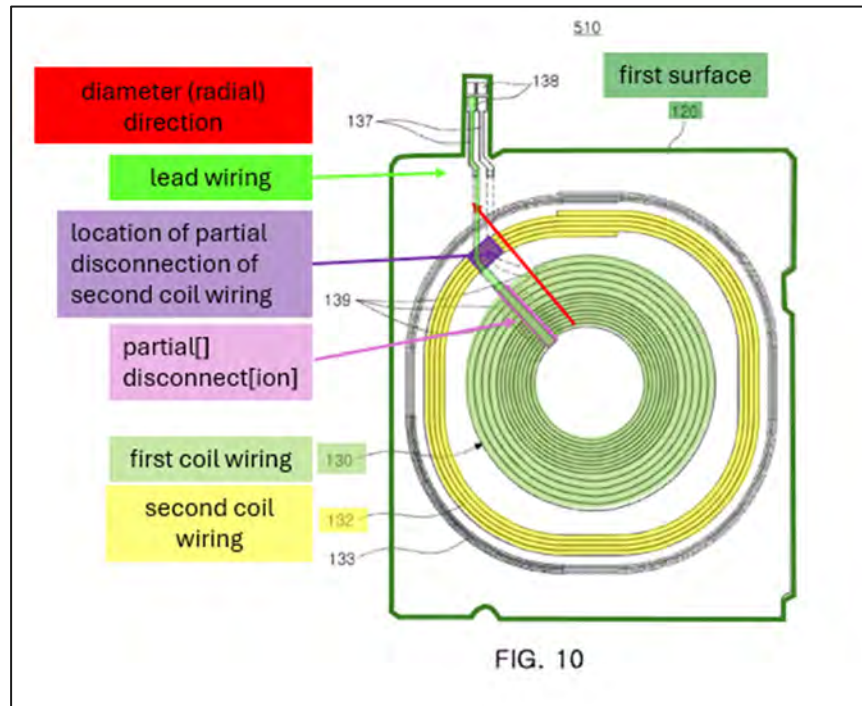

Ex1007 ¶73, Fig. 10; Ex1002 ¶232.

As shown above, the Ahn-721Lee combination renders obvious Ahn’s “**lead wirings 137**” extending along the “**diameter (radial) direction**” through both the **partial disconnection** of “**second coil wiring 132**” and the “**partial[] disconnect[ion]**” of “**first coil wiring 130.**” Ground 2 Limitations [1g]-[1h]; Ex1002 ¶233.

I. [1k]

The Ahn-721Lee combination renders this limitation obvious. Ex1002 ¶¶234-238.

Ahn teaches both ends of “**second coil wiring 132**” and “**first coil wiring 130**” on “**first surface 120**” (second major surface) “*need* to be connected to the connection pads 138.” Ex1007 ¶124. For “**first coil wiring 130**,” Ahn uses “**lead wirings 137**” running through the “**partial[] disconnect[ion]**” of “**first coil wiring 130**” “in a “**diameter (radial) direction**” to accomplish this connection. Ground 2 Limitation [1j]. A POSA would have understood that “**second coil wiring 132**” must be connected to the “connection pads 138” and it would have been logical to do so in the same way, i.e., by running an **outer lead wiring** through a **radially-extending outer gap** in the “**diameter (radial) direction**”:

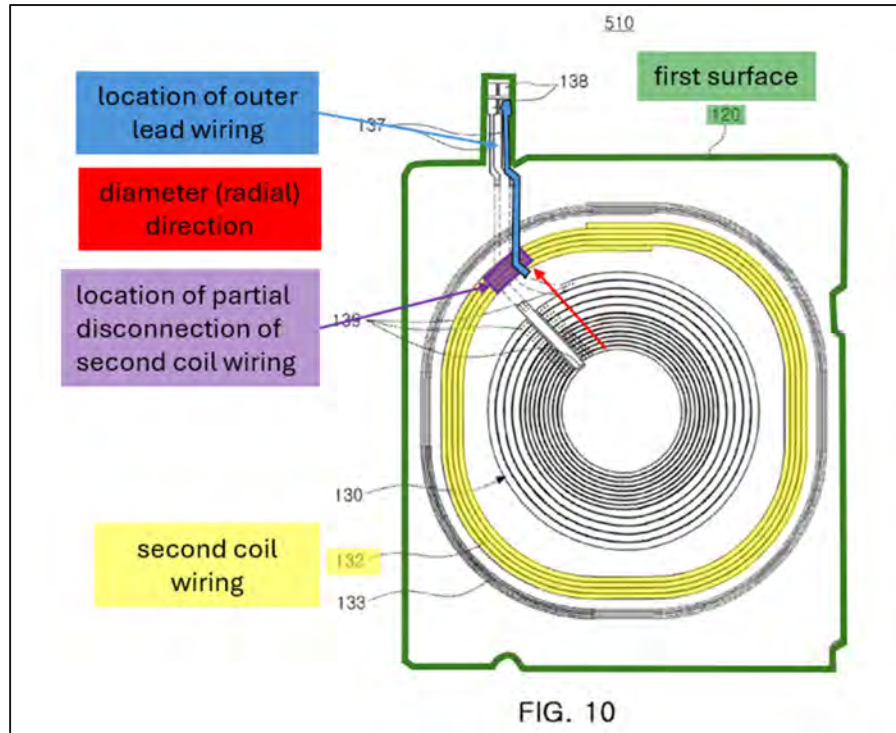

Ex1007, Fig. 10 (modified based on ¶124 to illustrate **outer lead wiring** and **radially-extending outer gap**); Ex1002 ¶235.

In addition, this limitation would have been obvious in view 721Lee. Ex1002 ¶¶236-238.

In 721Lee, “**MST patterns 1055**” formed on the “second layer” electrically connect “**MST coil 1050**” to “MST input/output terminals 1053 and 1054” and extend along the radial direction through the “**interval of the MST coil 1050.**” Ex1011 ¶140; Ex1002 ¶237.

It would have been obvious to incorporate 721Lee’s teachings of an outer antenna pattern comprising a radially-extending outer gap through which extension lines run with Ahn. Section VIII.B.1; Ground 2 Limitation [1g]. For similar reasons,

a POSA would have been motivated to run an outer extension line (like Ahn’s “lead wirings 137”) through a radially-extending outer gap, as 721Lee teaches, to connect Ahn’s second coil wiring 132 to connection pads 138 and would have reasonably expected success. Ex1002 ¶238.

**m. [11]**

Ahn teaches this limitation, or alternatively, the Ahn-721Lee combination renders it obvious. Ex1002 ¶¶239-243.

Ahn depicts “**lead wirings 137**” for “**first coil wiring 130**” extending “in a **diameter (radial) direction**”:

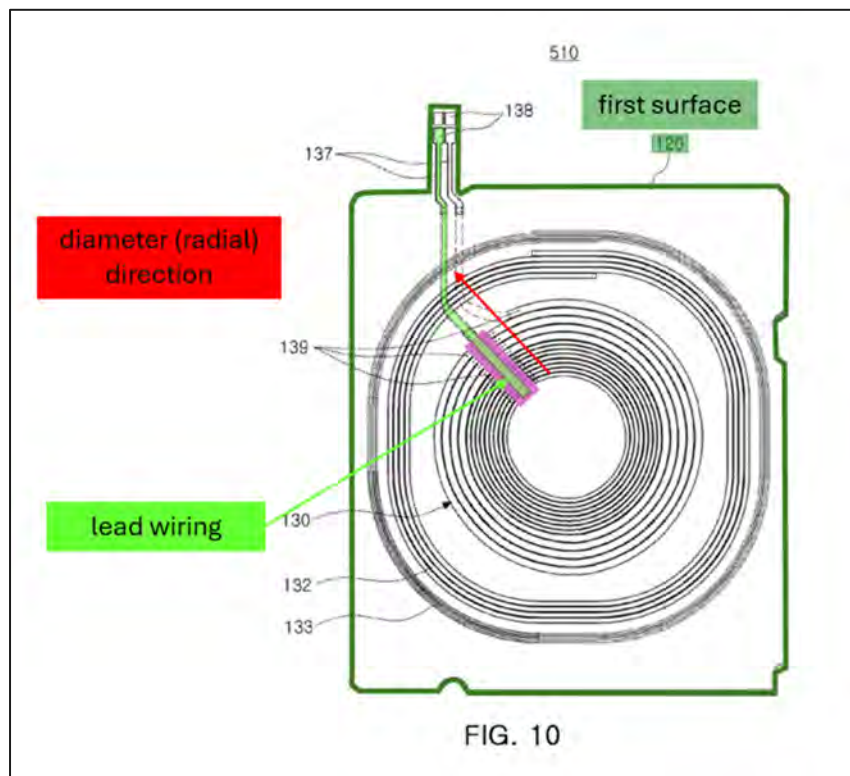

Ex1007 ¶¶69, 72–74, Fig. 10; Ex1002 ¶240.

Ahn teaches, and the Ahn-721Lee combination renders obvious, using “**lead wirings 137**” for “**second coil wiring 132**” and for “**third coil wiring 133**” that extend “in a **diameter (radial) direction.**” Ground 2 Limitations [1i]-[1k]. Ahn therefore teaches, and the Ahn-721Lee combination renders obvious, these three sets of “**lead wirings 137**” (two NFC extension lines, inner extension line, and outer extension line) extend substantially in parallel because they extend together in the same direction:

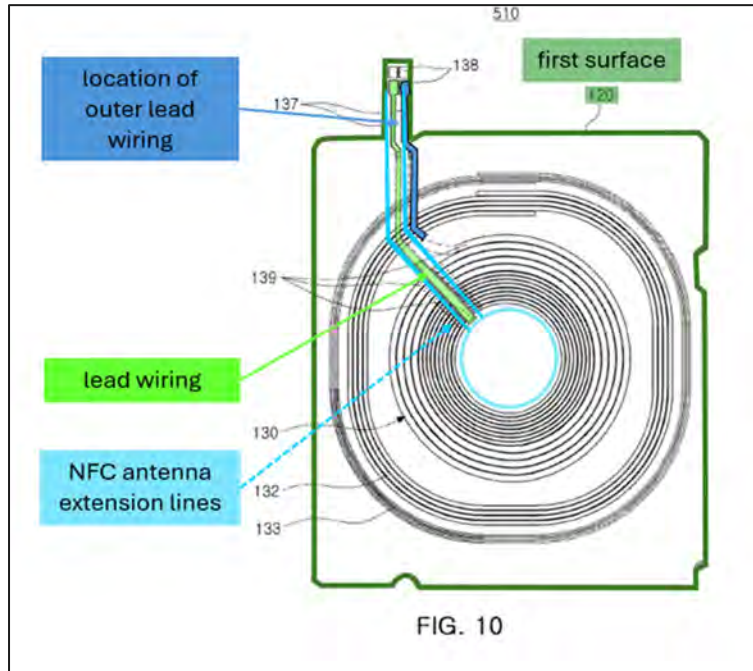

Ex1007, Fig. 10 (modified based on ¶¶124, 126 to illustrate the location of **outer lead wiring** and two **NFC antenna extension lines**); Ex1002 ¶241.

Further, 721Lee teaches these three sets of extension lines extend substantially in parallel:

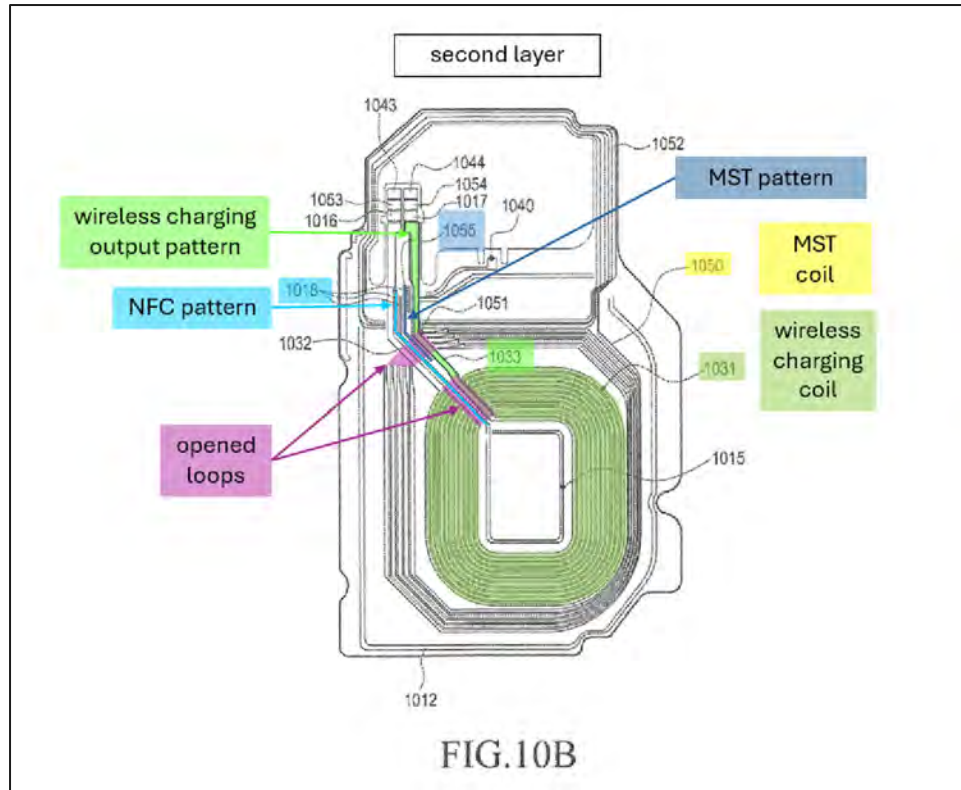

Ex1011, Fig. 10B; Ex1002 ¶242.

It would have been obvious to incorporate 721Lee’s radially-extending gap and extension-lines teachings with Ahn. Section VIII.B.1.

**n. [1m]**

Ahn teaches this limitation, or alternatively, the Ahn-721Lee combination renders it obvious. Ex1002 ¶¶244-249.

Ahn teaches, and the Ahn-721Lee combination renders obvious, using “**lead wirings 137**” that extend “in a **diameter (radial) direction**” to connect “**first coil wiring 130,**” “**second coil wiring 132,**” and “**third coil wiring 133**” to “connection pads 138.” Ground 2 Limitations [1i]-[1k].

Ahn further teaches each of the “**lead wirings 137**,” **outer lead wiring**, and two **NFC extension lines** overlap “**first section 1311**” on the “**second surface**.” Ex1002 ¶¶245-246. As can be seen by comparing Figures 10 and 4, Ahn teaches locating its coils up to the edges of the substrate, such that Ahn’s second major surface extension lines overlap Ahn’s first major surface outer coil (“**first section 1311**”):

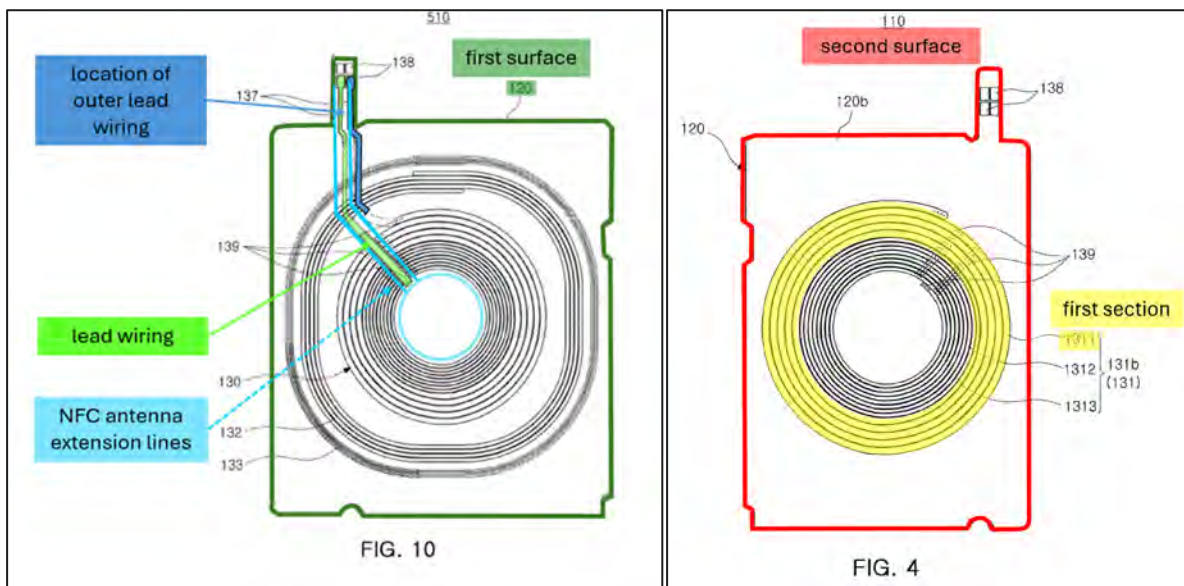

Ex1007, Figs. 4, 10 (modified to illustrate the location of **outer lead wiring** and two **NFC antenna extension lines**); Ex1002 ¶¶245-246.

In addition, a POSA would have found the overlapping extension lines obvious. Ex1002 ¶247. Ahn teaches the invention may vary in configuration and layout. Ex1007 ¶¶44, 77, 105, 126. There were a finite number of predictable configurations for Ahn’s coils and overlapping Ahn’s coils and extension lines on opposing surfaces would have furthered Ahn’s space-efficiency goal by increasing

compactness, reducing unused substrate space. Ex1007 ¶¶4, 65, 68, 99-100, 127; Ex1002 ¶247.

Further, this limitation would have been obvious in view of 721Lee. Ex1002 ¶¶248-249. 721Lee Figure 10C overlays the two different surfaces shown in 721Lee Figures 10A-10B, showing 721Lee’ “NFC pattern 1018” extension line (NFC antenna extension line), “MST patterns 1055” extension line (outer extension line), and “wireless charging output pattern” extension line (inner extension line) (collectively, the claimed extension lines on the second major surface) **overlap** with “MST coil 1021” (outer coil on first major surface):

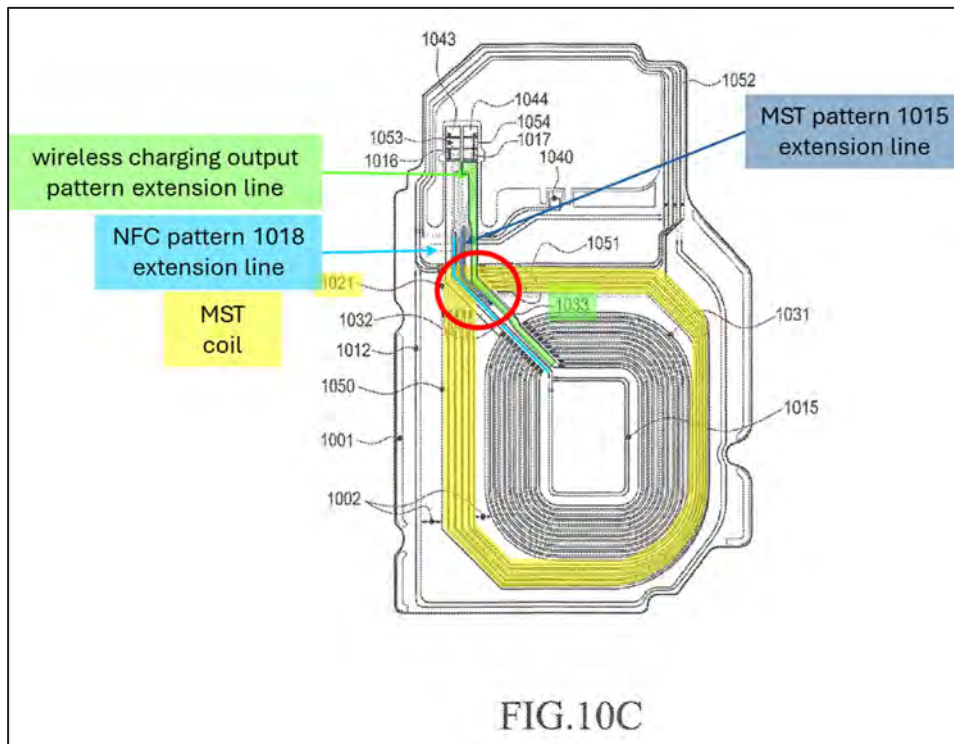

Ex1007, Fig.10C, ¶144. Ex1002 ¶248.

It would have been obvious to incorporate 721Lee's overlapping pattern design and gap teachings with Ahn to improve compactness and reduce unused substrate space. Section VIII.B.1.

**o. [1n]**

Ahn teaches this limitation, or alternatively, the Ahn-721Lee combination renders it obvious. Ex1002 ¶¶250-254.

Ahn's "first and second spiral wirings disposed on opposite surfaces of the substrate ... may be connected to each other in series or **in parallel**." Ex1007 ¶¶113, 120. "[F]eatures of the examples described [in the specification] may be combined in various ways," and "[s]uitable results may be achieved ... if components in a described system ... are combined in a different manner, and/or replaced or supplemented by other components." Ex1007 ¶¶45, 129.

If PO incorrectly argues Ahn does not teach a parallel electrical connection between "**second section 1312**" (inner coil) and "**first section 1311**" (outer coil), this arrangement would have been obvious. Ex1002 ¶252. There were only two electrical connection possibilities (in parallel or in series), and Ahn teaches electrically connecting wirings in parallel (Ex1007 ¶¶113, 120), so this it would have been obvious to try and a simple design choice to electrically connect "**second section 1312**" and "**first section 1311**" in parallel. Ex1002 ¶252.

Further, this limitation would have been obvious in view of 721Lee. Ex1002 ¶¶253-254 721Lee teaches “two coils ... may be connected **in parallel.**” 721Lee ¶152; *id.* ¶134 (“sub coils are connected in parallel” but “may be connected in series”).

A POSA reading Ahn and 721Lee would have understood electrically connecting coils in series or in parallel was a design choice and would have been motivated to try connecting Ahn’s inner and outer coils in parallel, which would have yielded predictable results. Ex1002 ¶254. 721Lee teaches antennas coils electrically connected in parallel have a lower recognition rate at higher distances than antennas with coils that are electrically connected in series, which means parallel connected coils may be more secure, and thus preferable for high-security applications, including NFC and payment transactions. 721Lee ¶¶158-59; Ex1002 ¶254. A POSA would have reasonably expected success because electrically connecting two coils in parallel was a well-known, straightforward electrical-connection method that Ahn and 721Lee teach. Ex1007 ¶¶113, 120, Figs. 8-9; Ex1002 ¶254.

### 3. [2]

The Ahn-721Lee combination renders claim 1 obvious and Ahn further teaches the remaining limitations of this claim. Ex1002 ¶¶255-256.

Ahn teaches “second spiral wiring 131a” (second antenna pattern) on the “**first surface**” (second major surface) and “first spiral wiring 131b” (first antenna pattern) on the “**second surface**” (first major surface) are “electrically connected to each other through **interlayer connection conductors 139**” (a plurality of vias):

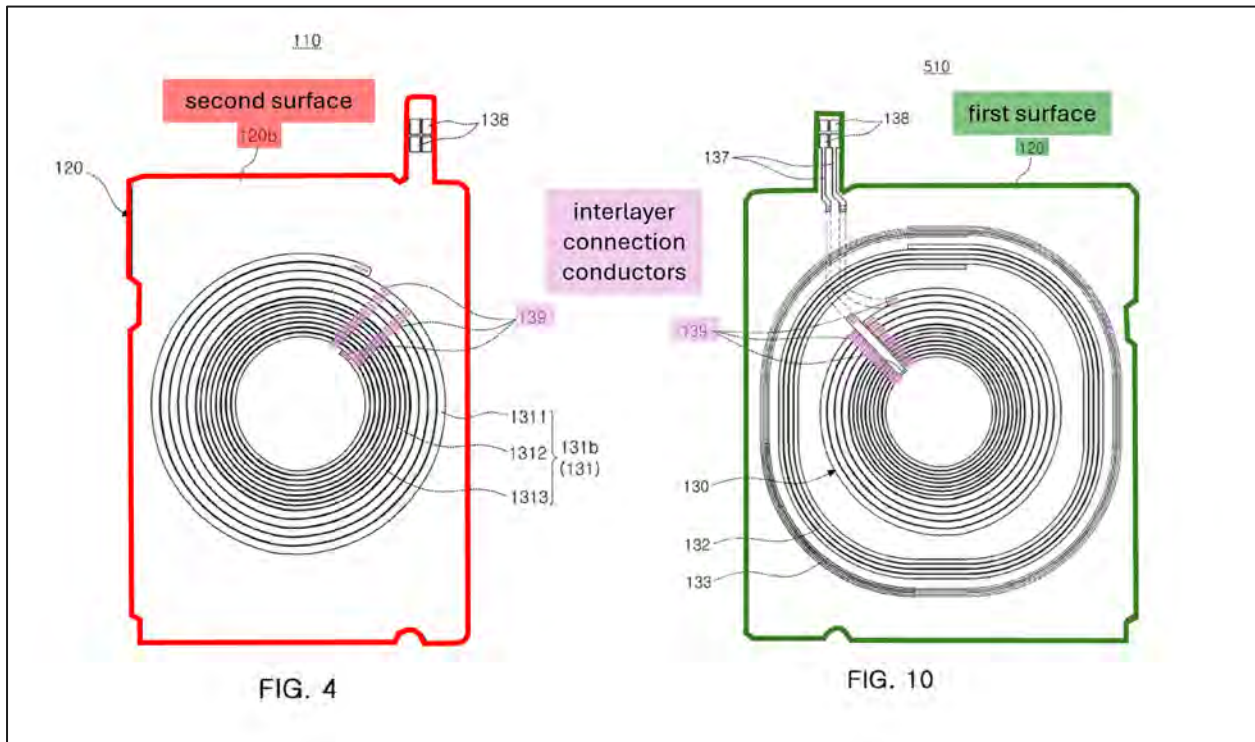

Ex1007 ¶¶13, 71, 74, 108, 113, 120, Figs. 4, 10, Cl. 8; Ground 2 Limitation [1a];  
Ex1002 ¶256.

#### 4. [3]

The Ahn-721Lee combination renders claim 1 obvious and further renders obvious the remaining limitations of this claim. Ex1002 ¶¶257-260.

The Ahn-721Lee combination renders obvious a **first inner extension line** formed on the **first surface**” (second major surface) that extends along the

“**diameter (radial) direction**” through both the **partial disconnection** of “**second coil wiring 132**” and the “**partial[] disconnect[ion]**” of “**first coil wiring 130.**”

Ground 2 Limitation [1j].

For the same reasons as Ground 2 Limitation [1j], Ahn also teaches a second “**lead wiring 137**” formed on the “**first surface**” (second major surface) that connects to “**first coil wiring 130**” and extends along the “**diameter (radial) direction**” through a **partial disconnection** of “**second coil wiring 132**”:

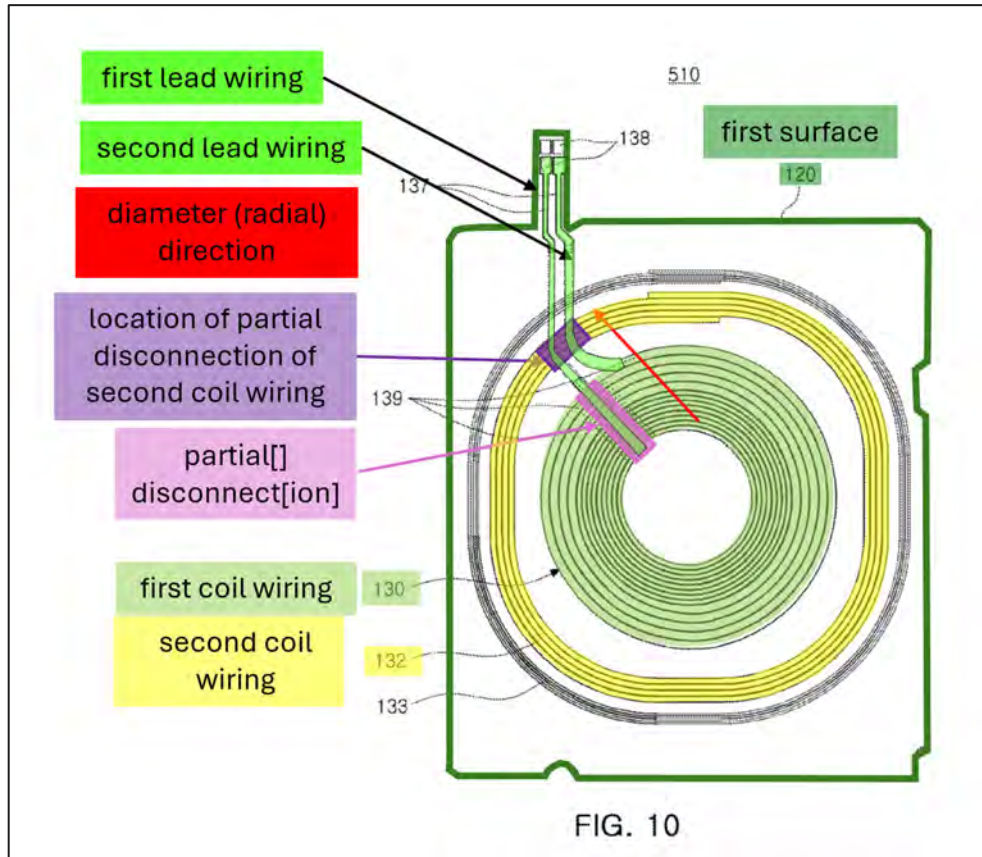

Ex1007, Fig. 10 (modified based on ¶¶72-73, 124 to illustrate **partial disconnection** of “**second coil wiring 132**”); Ground 2 Limitation [1g]; Ex1002 ¶¶258-259.

For the same reasons as Ground 2 Limitation [1j], a POSA would have understood Ahn teaches and the Ahn-721Lee combination renders obvious the first “**lead wiring[] 137**” connects an inner “first spiral wiring 131a” to one of the “connection pads 138,” by traversing the “**partial[] disconnect[ion]**” of “**first coil wiring 130**” and the second “**lead wiring[] 137**” also connects to “**first coil wiring 130**” and also extends along the “**diameter (radial) direction**” through the **partial disconnection** of “**second coil wiring 132**.” Ex1002 ¶260.

5. [4]

The Ahn-721Lee combination renders claim 1 obvious and Ahn further teaches the remaining limitations of this claim. Ex1002 ¶¶261-262.

In Ahn, “**second section 1312**” (inner coil) includes a wire line having a width different from that of a wire line of “**first section 1311**” (outer coil):

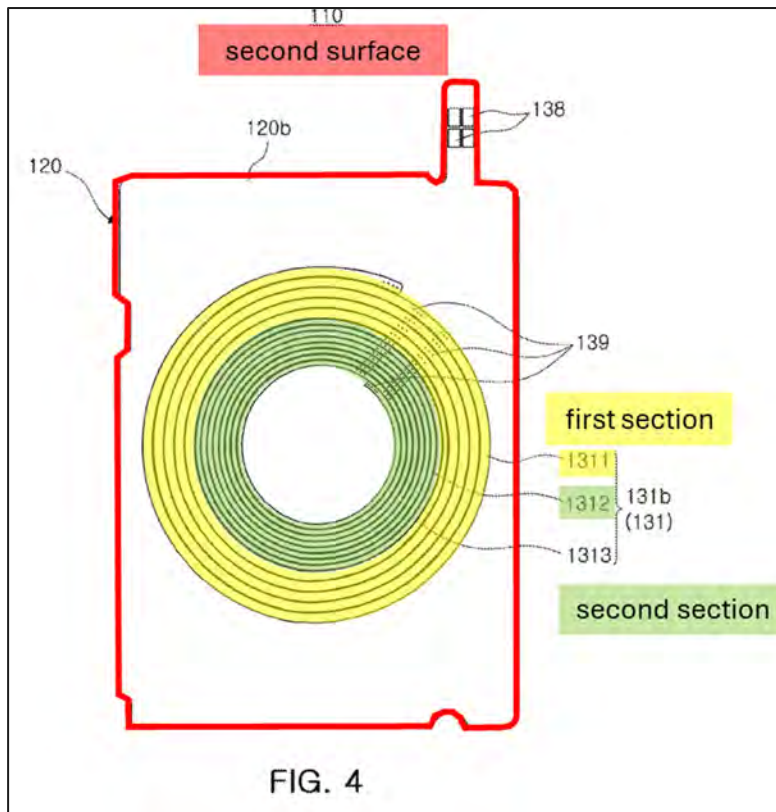

Ex1007, Fig. 4, ¶¶44, 76-77, 105, 126 (Ahn’s coils “may have different widths”);  
Ex1002 ¶262.

6. [5]

The Ahn-721Lee combination renders claim 1 obvious and Ahn further teaches the remaining limitations of this claim. Ex1002 ¶¶263-265.

In Ahn, “**second section 1312**” (inner coil) has a first number of turns that is greater than that of “**first section 1311**” (outer coil):

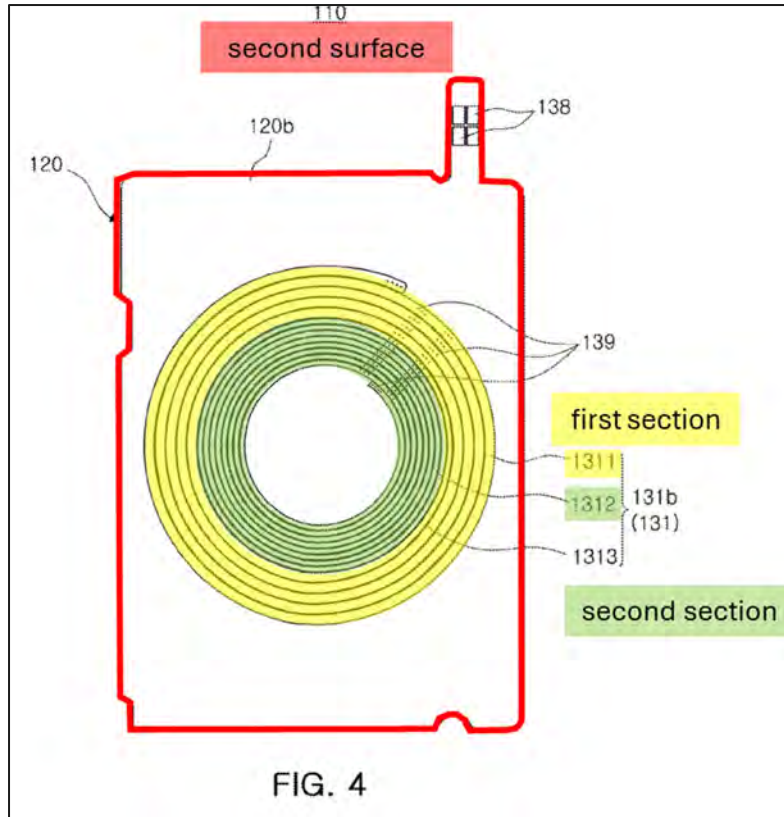

Ex1007, Fig. 4, ¶¶8, 22, 44, 76-77, 82, 85-87, 89-90, 98, 105, 109, 126, Cls. 3, 17;  
Ex1002 ¶264.

As shown above, Ahn depicts “**second section 1312**” having approximately 13 turns, and “**first section 1311**” having approximately 5 turns. Ex1007, Fig. 4;  
Ex1002 ¶265.

7. [6]

The Ahn-721Lee combination renders claim 1 obvious and Ahn further teaches the remaining limitations of this claim. Ex1002 ¶¶266-268.

Ahn teaches a smartphone “configured to wirelessly transmit power”:

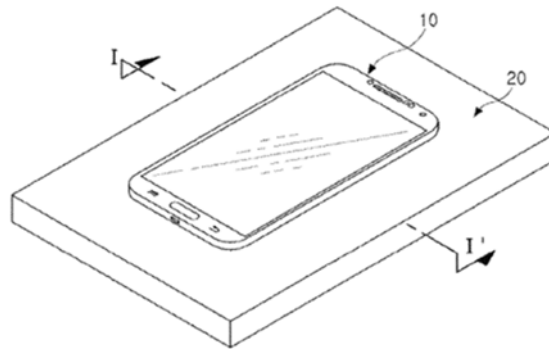

FIG. 1

Ex1007 ¶¶3-4, 48-49, Figs. 1-2; Ex1002 ¶267.

Ahn’s outer and inner coils are configured for wireless battery charging (they “may be used to transmit and receive power for wireless charging.”). Ex1007 ¶¶48-49, 52, 125, Fig. 2; Ground 2 Limitation [1a]; Ex1002 ¶268. Therefore, a POSA would have understood “**first section 1311**” and “**second section 1312**” are configurable for wireless battery charging. Ex1002 ¶268.

**C. Ground 3: 005Lee Renders Claims 1-6 Obvious in view of Seong and Cho**

**1. Motivation To Combine 005Lee, Seong, and Cho**

These references overcome limited space in smartphones with space-efficient WPC, NFC, and MST antennas, optimizing shape and layout, including placing coils on both sides of a substrate. Section V. A POSA reading 005Lee would have been motivated to incorporate Seong’s and Cho’s teachings. Ex1002 ¶¶269-280. All these references teach antenna patterns on both sides of a substrate in a smartphone, including WPC, NFC, and MST antennas. Ex1008, 17:4-9, Figs. 4A-4B, 43D;

Ex1006, ¶¶4, 33-34, 77, Figs. 5-6; Ex1010 Cl. 2, 10; ¶¶66-67, 73; Ex1002 ¶269. If 005Lee is found to not teach a claimed limitation, as discussed below, it would have been obvious to a POSA to adopt well-known, predictable, and finite approaches taught by Seong and/or Cho to achieve wireless-communication functions in a space efficient module. Ex1002 ¶269.

*First*, a POSA reading 005Lee would have been motivated to incorporate Seong’s Figure 6 “bottom surface” coil teachings. Ex1002 ¶270. 005Lee teaches forming coils on opposing sides of a substrate. Ex1008, 17:4-9 (“Each of the conductive patterns” “can be formed on one surface” “or the other surface.”), 27:58-67 (“first and second coils” “can be formed in” “different layers (or surfaces) of the flexible printed circuit board”), Figs. 4A-4B, 43D (coils on both substrate sides). However, 005Lee provides detailed coil layouts only for one substrate side. Ex1008, Fig. 5B. A POSA would have been motivated to look for similar references teaching possible coil layouts for 005Lee’s substrate’s other side, including Seong. Ex1002 ¶270.

As explained in Ground 1, like 005Lee, Seong teaches space-efficient coils, including an innermost **NFC pattern**, surrounded by an **inner MST coil** and an **outer WPC coil**, formed on both substrate sides:

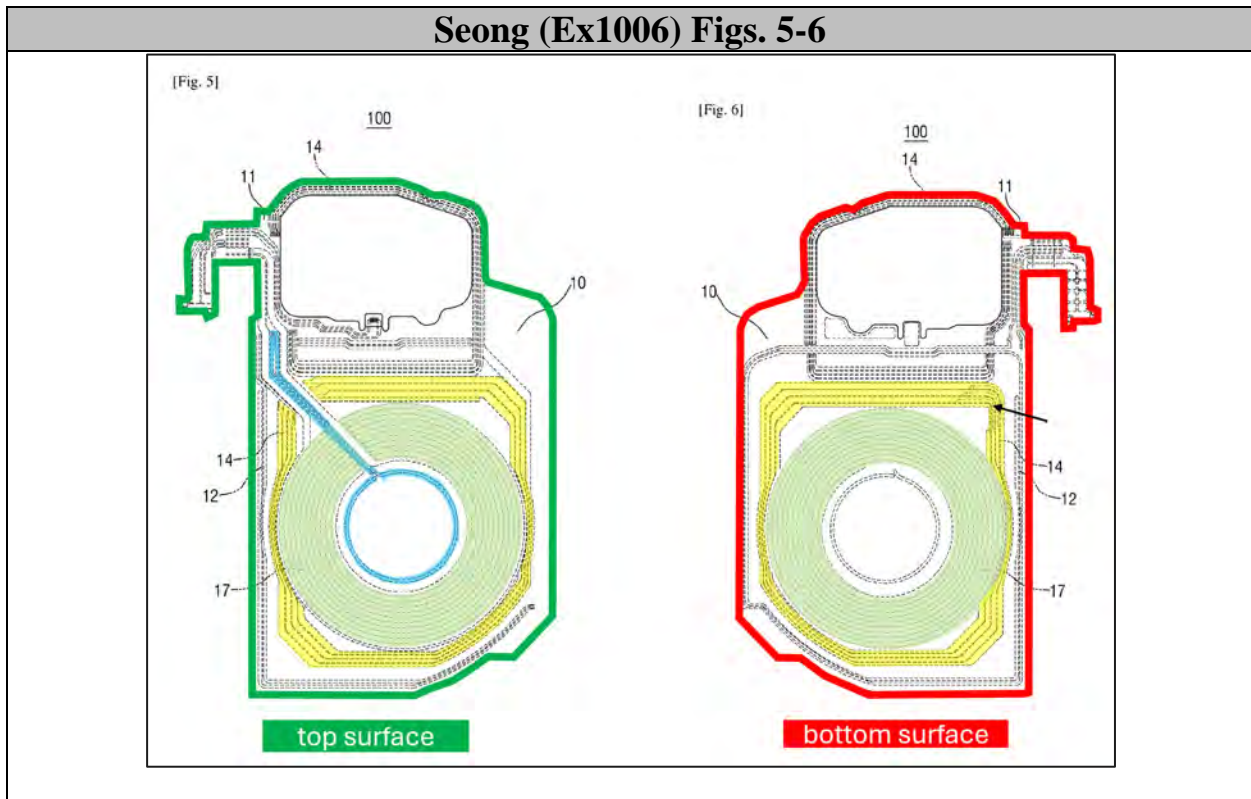
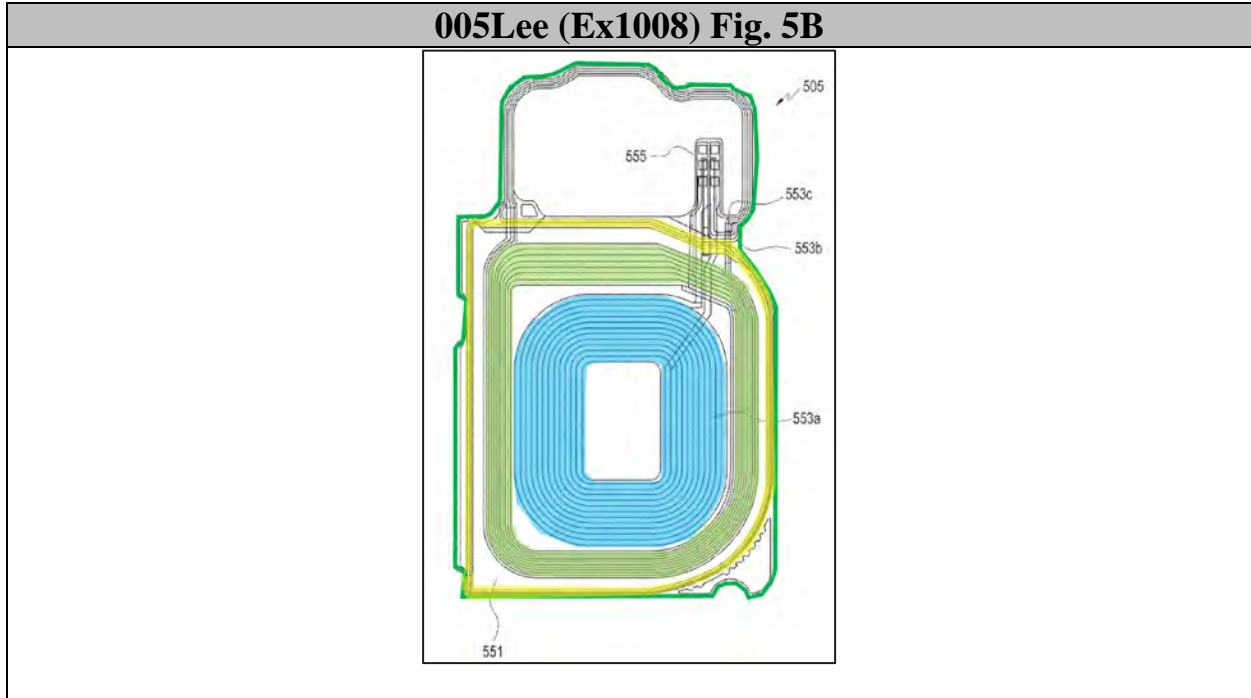

Ex1008, Fig. 5B; Ex1006, ¶¶4, 33-34, 77, Figs. 5-6; Ex1002 ¶271.

Given their similarities, a POSA would have been motivated to implement 005Lee's teachings of forming coils on both substrate surfaces with Seong's Figure 6, which shows coils on a substrate's bottom surface, opposite similar patterns on the top surface, as shown in Seong Figure 5 and 005Lee Figure 5B. Ex1006, Figs. 5-6; Ex1008, Fig. 5B; Ex1002 ¶272; Ground 1. This would have combined known elements according to known methods (forming known coil patterns on both substrate sides, as 005Lee and Seong teach) to achieve predictable wireless-communication results furthering both references' space-efficiency goal. Ex1002 ¶272.

A POSA would have reasonably expected success. Ex1002 ¶273. As noted, 005Lee teaches forming coils on both substrate sides and teaches using various coil shapes, and Seong provides concrete examples of how to implement such coils. Forming coils on both substrate sides was common, and Seong's disclosure provides details a POSA would have used to effectively implement 005Lee's teachings. *Id.*

**Second**, if PO incorrectly argues 005Lee does not teach running its extension lines through coil gaps, a POSA would have found this arrangement obvious in view of Seong. Ex1002 ¶274. 005Lee runs extension lines between its "connection piece" and its "conductive patterns" to electrically connect them "to the control circuit." Ex1008, 17:52-57, Fig. 5B. 005Lee Figure 5B depicts extension lines crossing its conductive patterns. *Id.* A POSA would have understood 005Lee

teaches gaps in its conductive patterns for extension lines because extension lines cannot touch conductive patterns without causing short-circuiting. Ex1002 ¶274.

In addition, a POSA would have found this approach obvious. Ex1002 ¶275. Reading 005Lee, a POSA would have been motivated to look to references, including Seong, furthering the same space-efficient goals by running extension lines past conductive patterns without touching. *Id.* Ex1006, Abstract, Fig. 5; Ground 1. 005Lee and Seong teach similar ways of achieving this (concentric coils on multiple surfaces with extension lines). Ex1008, Fig. 5B; Ex1006, Fig. 5; Ex1002 ¶27. Running extension lines through coil gaps was well-known and improves space efficiency by letting the coils be arranged in a space-efficient, concentric manner. Ex1006, Fig. 5; Ex1014 ¶31 (coil gaps improve space efficiency by up to 70%); Ex1002 ¶275.

A POSA would have reasonably expected success. Ex1002 ¶276. 005Lee teaches using extension lines connecting coils to “connection piece 555.” Ex1008, 17:52-57, Fig. 5B. 005Lee teaches using various antenna shapes and layouts. Ex1008, 17:67-18:4, 19:28-35. Incorporating Seong’s coil-gaps teachings would have been a straightforward implementation of a known coil-pattern layout to achieve predictable results of space-efficient concentric coils. Ex1002 ¶276.

**Third**, a POSA would have been motivated to incorporate Cho’s teachings of electrically connecting inner and outer coils in parallel with 005Lee. Ex1002 ¶277.

Cho’s “wireless communication coil” comprises a “first coil portion” and a “second coil portion[,]” which “may be connected in series or in parallel.” Ex1010 ¶¶90, 91. There are only two electrical connection possibilities—in parallel or in series, as Cho teaches—so it would have been obvious to try and a simple design choice to electrically connect 005Lee’s inner and outer conductive patterns in parallel to yield predictable results. Ex1002 ¶277.

A POSA would have reasonably expected success because electrically connecting two coils in parallel was a well-known, straightforward electrical-connection method as Cho teaches. Ex1010 ¶¶90, 91; Ex1002 ¶278.

*Fourth*, a POSA would have been motivated to incorporate Seong’s and Cho’s teaching of connecting coils on opposing surfaces using vias with 005Lee. Ex1002 ¶279. 005Lee teaches coils on opposing substrate surfaces and “a connection element” containing “conductive material” that “electrically interconnect[s]” them. Ex1008, 21:39-51. Seong teaches connecting coils on different surfaces using vias. Ground 1 Claim 2. Cho also teaches “wireless charging coil 111 on one surface 11 of the substrate may be connected through via holes to the wireless charging coil 112 formed on the other surface 12 of the substrate.” Ex1010 ¶¶66-67, Cls. 2, 10. Seong’s and Cho’s teachings of connecting coils on two opposite substrate surfaces using a plurality of vias was a common and effective way to connect 005Lee’s opposing-surface antenna patterns, and vias

would have been obvious to try as one of a finite number of predictable solutions for this purpose. Ex1002 ¶279.

A POSA would have reasonably expected success. Ex1002 ¶280. Vias were commonly used for this purpose, would have been straightforward to implement, and 005Lee already teaches electrically interconnecting various components. *Id.*

**2. [1]**

**a. [1pre]**

To the extent the preamble is limiting, 005Lee teaches it. Ex1002 ¶¶281-283.

005Lee teaches a “smartphone” including a “flexible printed circuit board” comprising “a plurality of loop antennas” and “conductive patterns” for “NFT,” “MST,” and “wireless charg[ing]”:

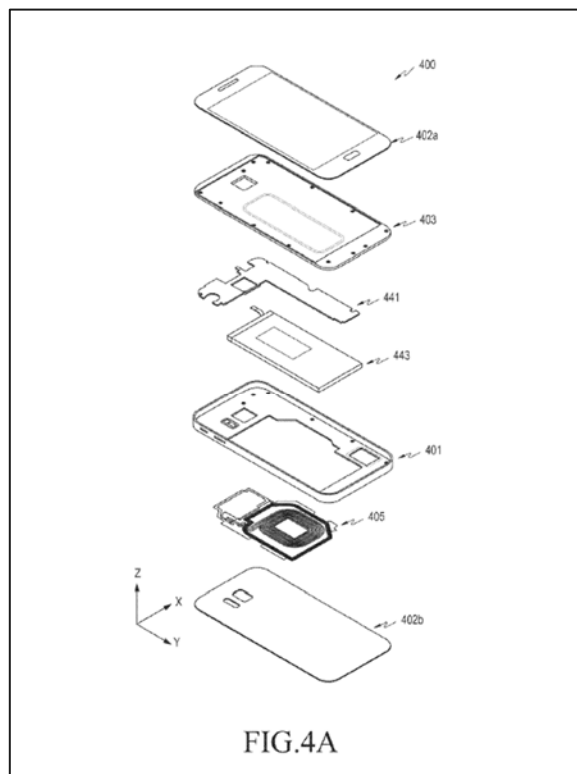

Ex1008, 1:65–67, 6:23, 17:24–31, 19:5–12, Fig. 4A.

This is a smartphone antenna module including because it comprises multiple antennas. Ex1002 ¶283.

**b. [1a]**

005Lee teaches this limitation. Ex1002 ¶¶284-286.

005Lee teaches “**base member 551**” (substrate) can be “in the form of a multi-layer circuit board” with “loop antennas for **NFT**, **MST**” and “wireless charge” and “[e]ach of the conductive patterns ... can be formed on **one surface** of the base member 551 or the **other surface**” of the “**base member 551**”:

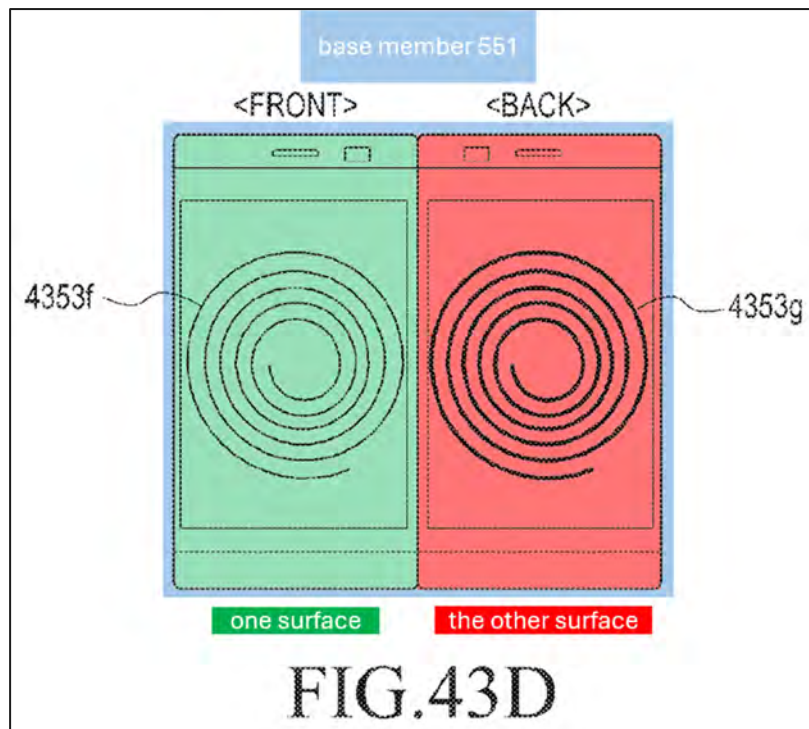
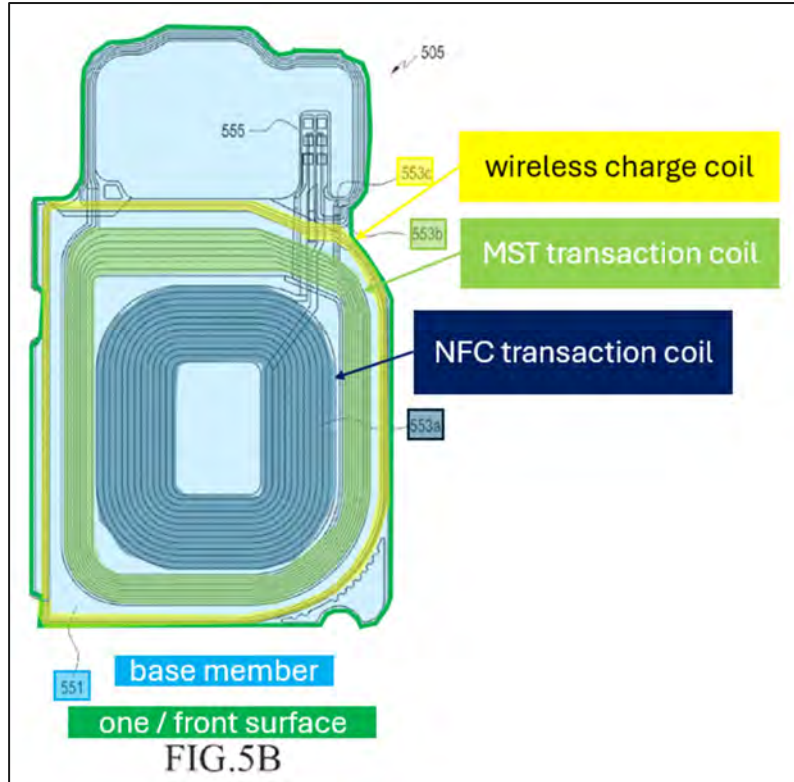

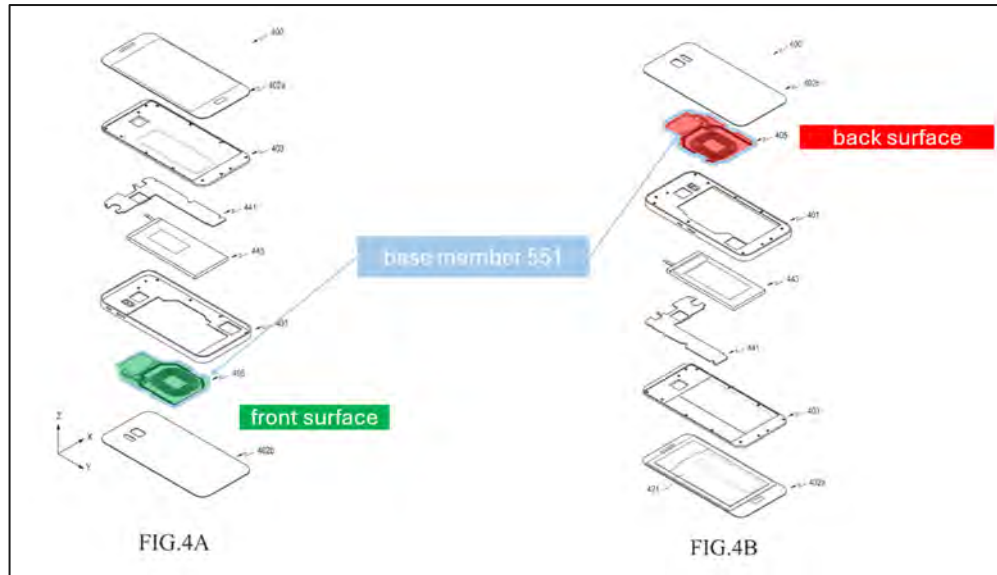

Ex1008, 17:4–19, 18:36–40, 19:5–12, 49:59–62, Figs. 4A (depicting “**one surface**” from a top view), 4B (depicting “**other surface**” from a bottom view), 5B (depicting “**one [/front] surface**”), 43D (depicting coil antennas “separated from each other” on the “**front**” and “**back**” surfaces), 27:58–67 (“the first and second coils” “can be formed in” “different layers (or surfaces) of the **flexible printed circuit board**”); Ex1002 ¶285.

The “**other surface**” / “**back**” surface of 005Lee’s “**base member 551**” is the claimed first major surface, and the “**one surface**” / “**front**” surface (depicted in Figure 5B) is the claimed second major surface facing away from the first major surface. Ex1002 ¶286.

**c. [1b]**

005Lee in view of Seong renders this limitation obvious. Ex1002 ¶¶287-291.

As explained in Ground 3 Limitation [1a], 005Lee teaches forming antenna patterns on the “**other surface**” / “**back**” surface. Ex1008, Figs. 4B, 43D; Section VIII.C.1. However, 005Lee does not explicitly disclose the details of the antenna patterns for this surface. Thus, a POSA would have been motivated to look for teachings of complementary coil layouts for the “**other surface**” / “**back**” surface. Ex1002 ¶288.

Seong teaches a first antenna pattern on the “**bottom surface**” (claimed first major surface) comprises a **first central portion**, “**WPC pattern 17**” (first inner ring portion) surrounding the **first central portion**, and “**MST pattern 14**” (first outer ring portion) surrounding “**WPC pattern 17**”:

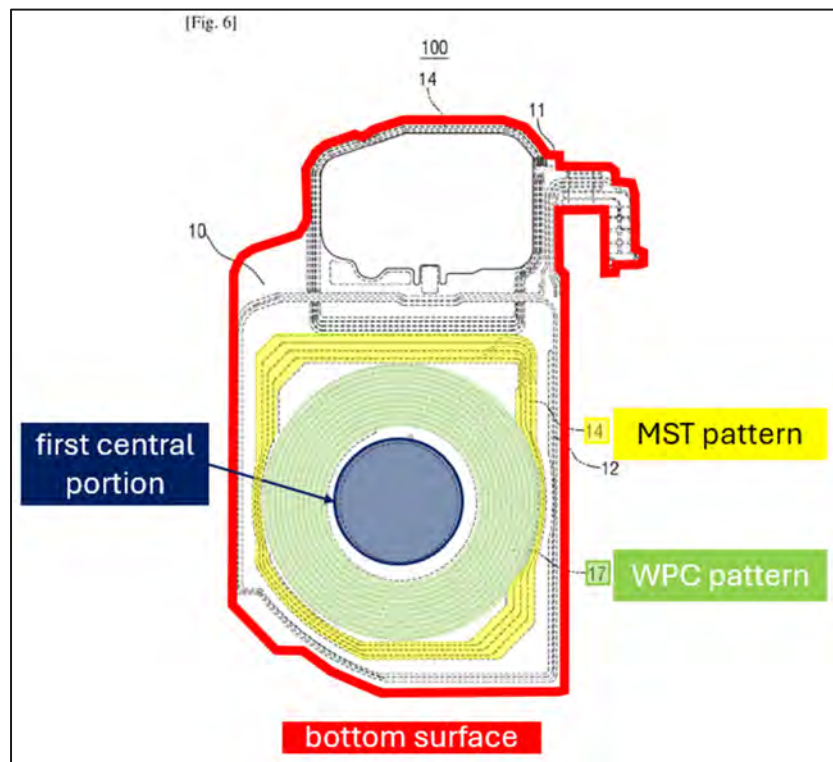

Ex1006 ¶64, Fig. 6; Ground 1 Limitation [1b]; Ex1002 ¶289.

It would have been obvious to incorporate Seong's "bottom surface" coil antenna pattern teachings with 005Lee. Section VIII.C.1.

Further, if the claimed "ring portion[s]" must be circular, 005Lee teaches that arrangement. Ex1008, 19:28-34 (concentric circles can be used); Ex1002 ¶291.

**d. [1c]**

005Lee in view of Seong renders this limitation obvious. Ex1002 ¶¶291-295.

005Lee teaches the "front" surface (second major surface) of "base member 551" comprises an area occupied by "first conductive pattern 553a" (second central portion), an area occupied by "second conductive pattern 553b" (second inner ring portion), which surrounds the area occupied by "first conductive pattern 553a," and an area occupied by "third conductive pattern 553c" (second outer ring portion), which surrounds the area occupied by "second conductive pattern 553b":

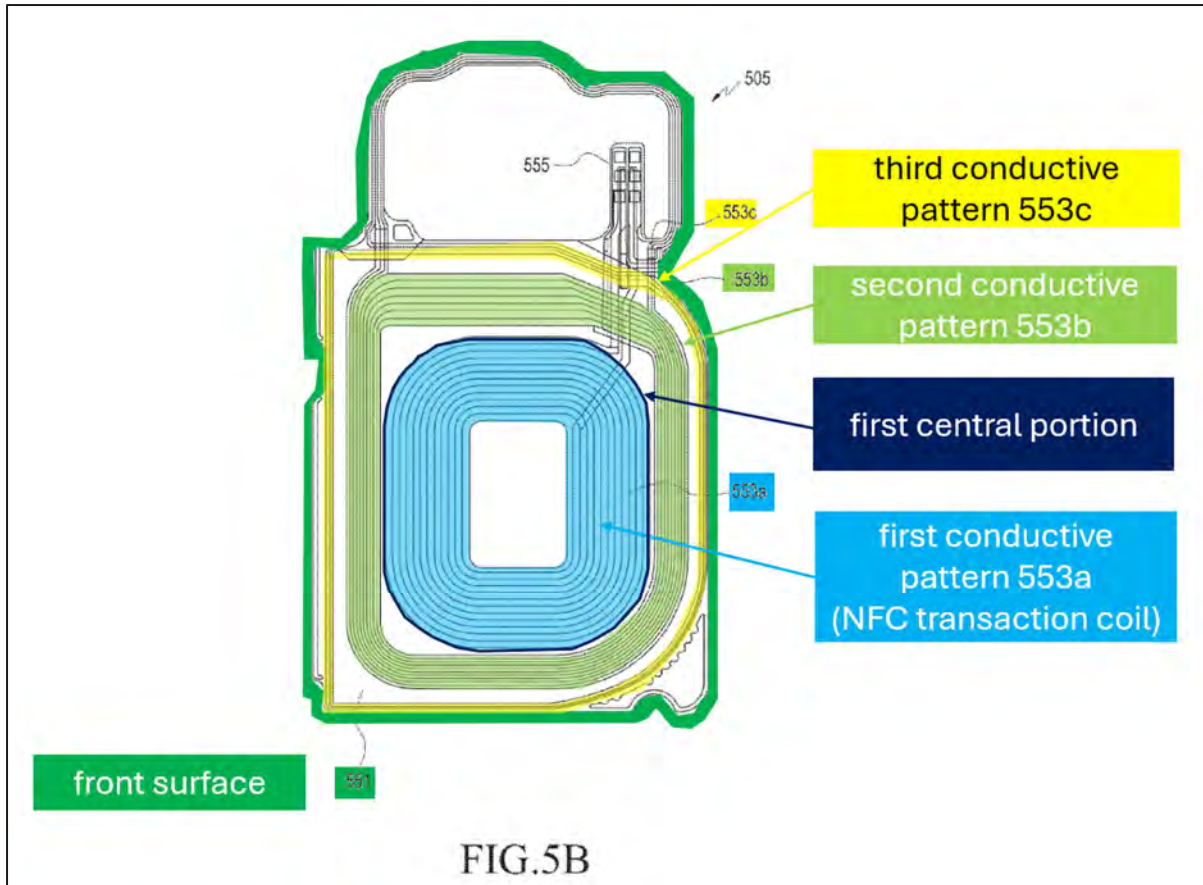

Ex1008, 17:4–19, Fig. 5B; *id.*, Fig. 43D; Ex1002 ¶292.

005Lee teaches the areas occupied by “**first conductive pattern 553a**,” “**second conductive pattern 553b**,” and “**third conductive pattern 553c**” on the “**front**” surface (second major surface) overlap the areas occupied by “**first conductive pattern 553a**,” “**second conductive pattern 553b**,” and “**third conductive pattern 553c**” on the “**back**” surface (first major surface), respectively:

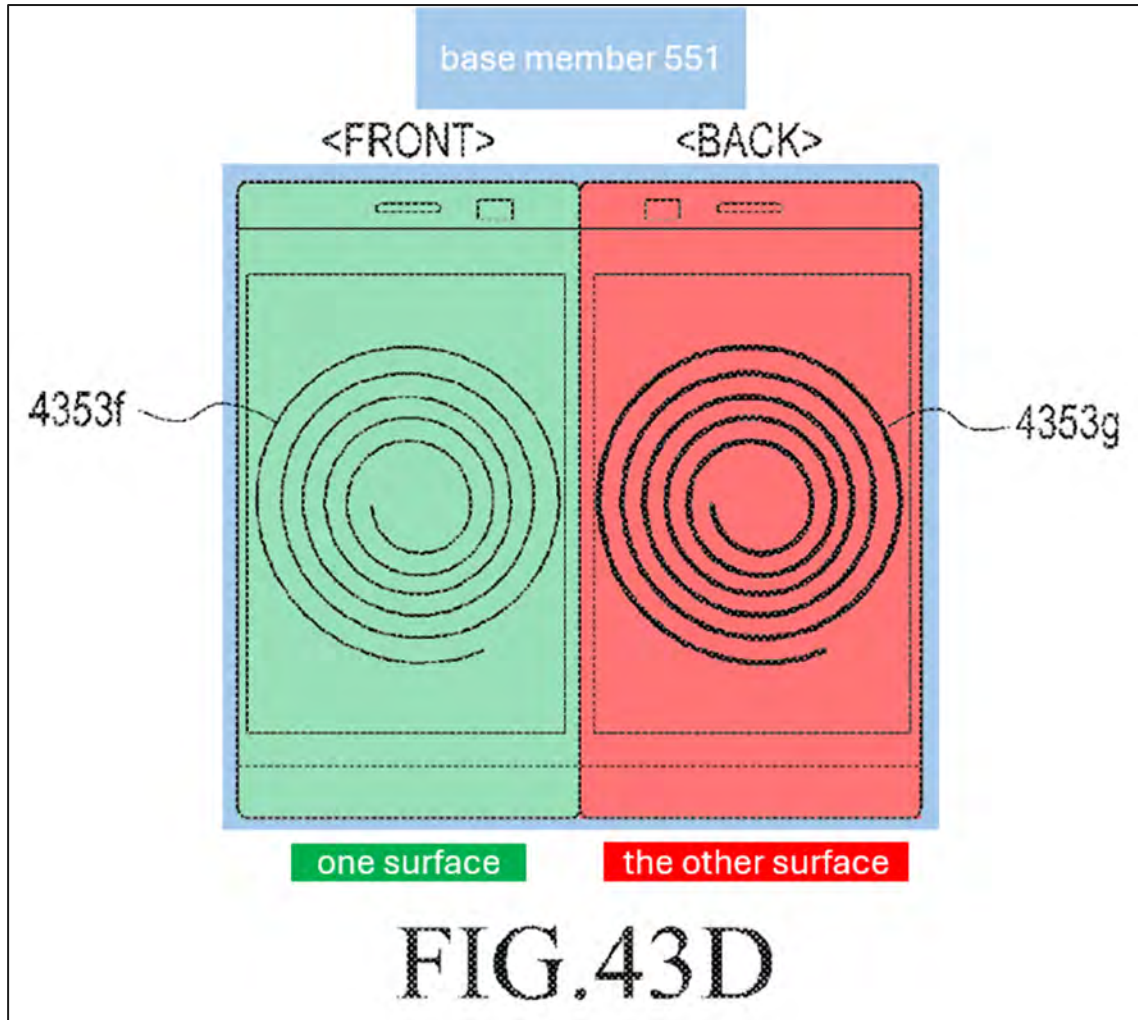

Ex1008, 17:4-19, 18:36-40, 19:5-12, 49:59-62, Fig. 43D; Ex1002 ¶293.

It would have been obvious to incorporate Seong's "bottom surface" coil-pattern teachings with 005Lee. Section VIII.C.1. 005Lee in view of Seong satisfies this limitation:

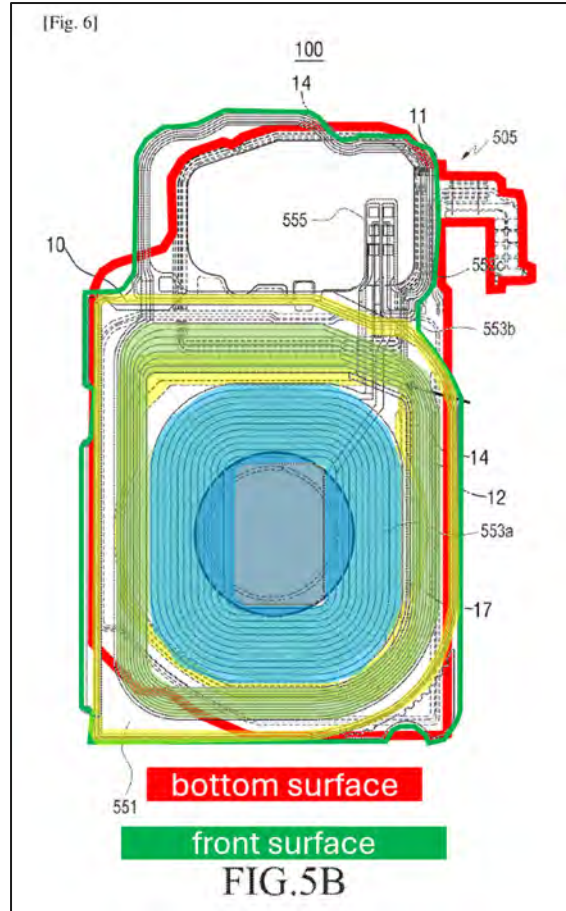

Combined Ex1008, Fig. 5B with Ex1006, Fig. 6; Ex1002 ¶294.

e. [1d]

005Lee in view of Seong renders this limitation obvious. Ex1002 ¶¶296-298.

Seong teaches this limitation:

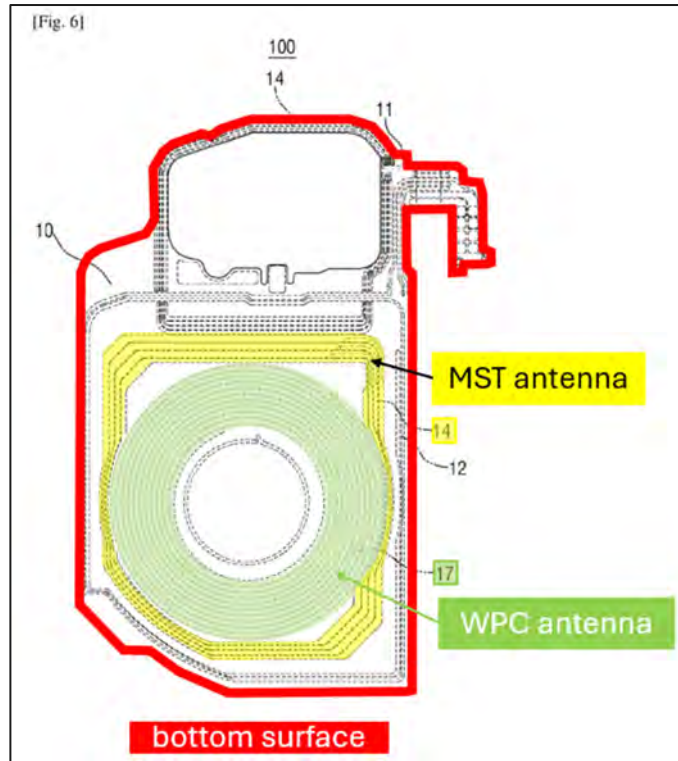

Ex1006 ¶64, Fig. 6; Ex1002 ¶297; Ground 1 Limitation [1d].

It would have been obvious to incorporate Seong’s “bottom surface” coil pattern teachings with 005Lee. Section VIII.C.1.

**f. [1e]**

005Lee teaches this limitation. Ex1002 ¶¶299-300.

005Lee teaches a second antenna pattern formed on the “**front**” surface (second major surface) comprising an “**NFC transaction coil** (the **first conductive pattern 553a**)” (NFC antenna pattern formed on the second central portion), **MST coil 553b** (inner antenna pattern formed on the second inner ring portion) and **wireless charge coil 553c** (outer antenna pattern on the second outer ring portion):

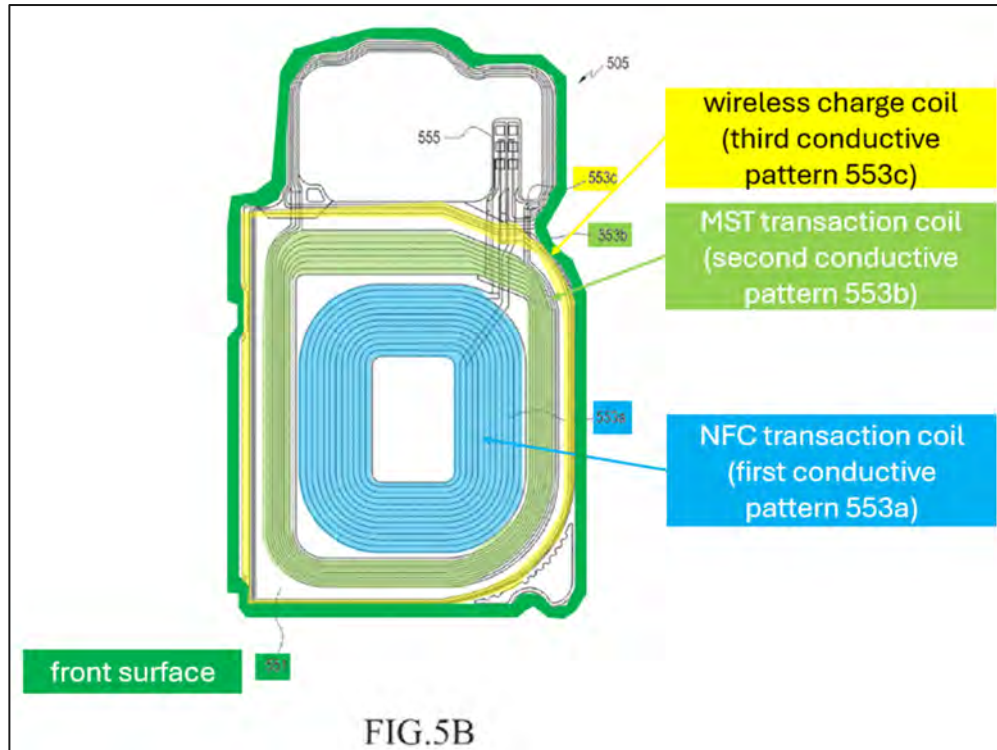

Ex1008, 17:14-16, 19:28-34, Fig. 5B; Ex1002 ¶300.

**g. [1f]**

005Lee teaches this limitation or alternatively, renders it obvious in view of Seong. Ex1002 ¶¶301-307.

005Lee teaches the inner antenna pattern comprising a plurality of concentric **C-shaped lines** of the **MST transaction coil** forming a **radially-extending inner gap** on the portion occupied by the “**second conductive pattern 553b**” (second inner ring portion), especially when using 005Lee’s concentrically circular coils:

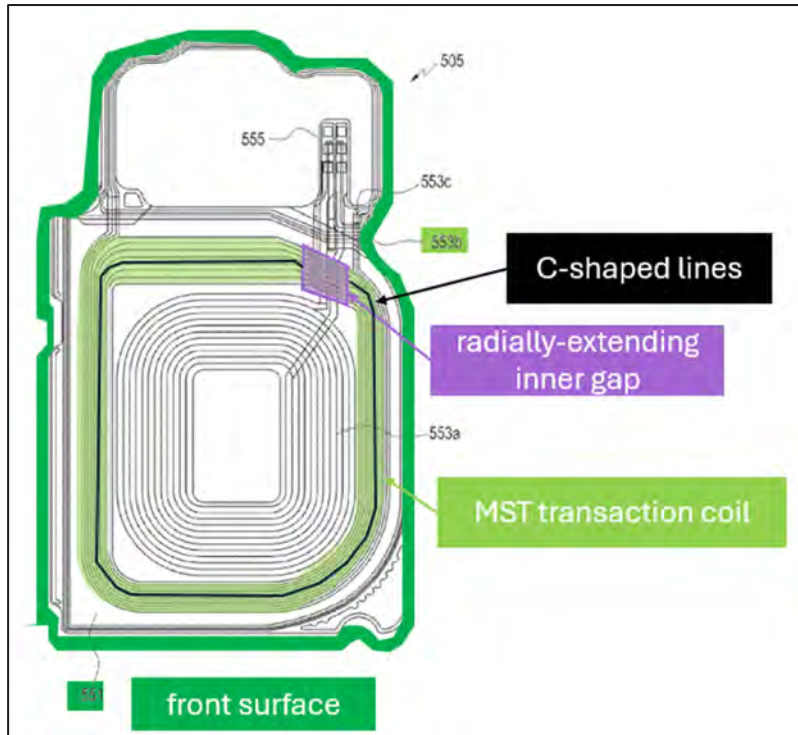

Ex1006, 19:28-34, Fig. 5 (modified to illustrate **radially-extending inner gap**);

Ex1002 ¶302.

This is at least as much disclosure as PO contends infringes:

500Lee, Fig. 5B	Ex1015, 9
<p>This diagram is identical to the one in Ex1006, Fig. 5. It shows a top-down view of a device's front surface with concentric C-shaped lines and a radially-extending inner gap. Labels include: '505', '555', '553c', '553b', '553a', 'C-shaped lines', 'radially-extending inner gap', 'MST transaction coil', and 'front surface'.</p>	<p>This is a photograph of a device's front surface. A pink arrow points to the inner antenna pattern, labeled 'Inner antenna pattern with concentric C-shaped lines'. A blue arrow points to the gap between the lines, labeled 'Radially-extending inner gap'.</p>

A POSA would have understood that 005Lee’s Figure 5B shows a **radially-extending inner gap**. Ex1002 ¶304. 005Lee teaches “connection piece 555” “connect[s] the **conductive patterns 553a**, 553b, and 553c to the control circuit” and depicts **NFC extension lines** performing this connection:

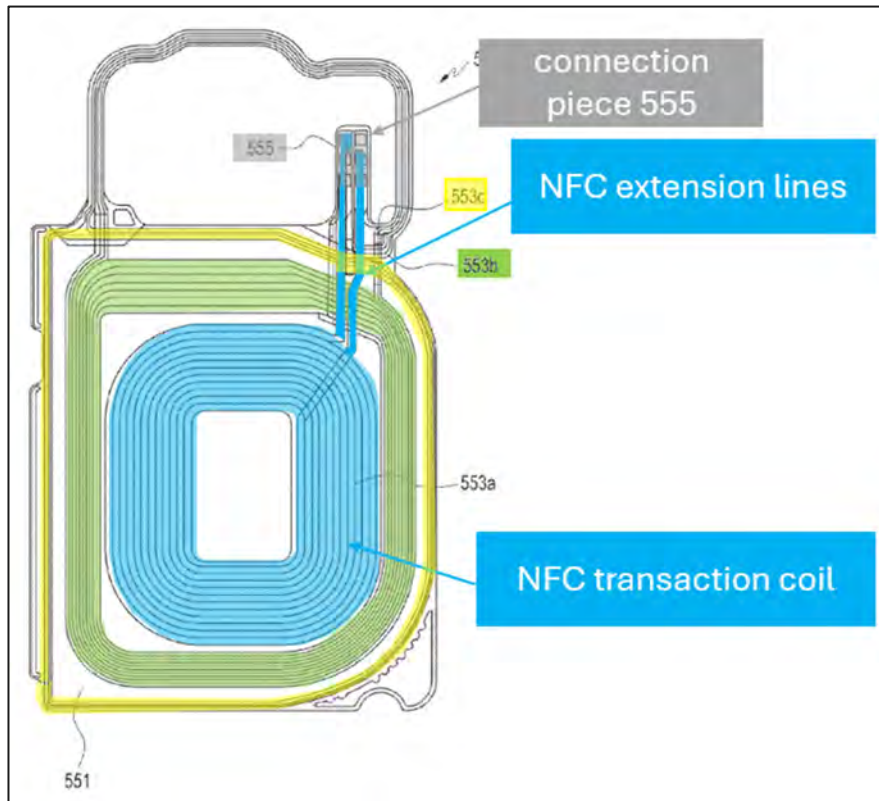

Ex1008, 17:52-57, Fig. 5B; Ex1002 ¶304.

For the depicted **NFC extension lines** to function without interfering with conductive patterns **553b** and **553c**, extension lines and conductive patterns cannot touch, as such contact would cause short circuiting. Ex1002 ¶305. Thus, a POSA would have understood a **radially-extending inner gap** exists through which **NFC extension lines** run.

In addition, it would have been obvious to use a **radially-extending inner gap** in view of Seong. Section VIII.C.1.

Seong teaches a **radially-extending inner gap**:

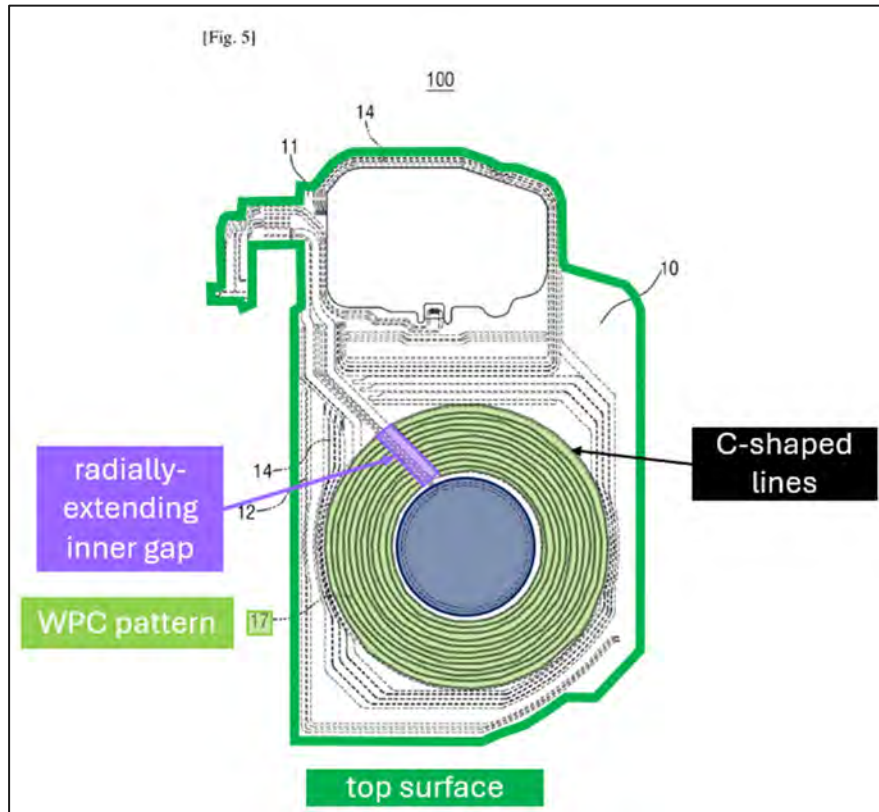

Ex1006, Fig. 5; Ex1002 ¶¶306-307; Ground 1 Limitation [1f].

**h. [1g]**

005Lee teaches this limitation or alternatively, renders it obvious in view of Seong. Ex1002 ¶¶308-311.

005Lee teaches the **wireless charge coil 553c** (outer antenna pattern) comprising a plurality of concentric **C-shaped lines** forming a **radially-extending outer gap** on the area occupied by “**third conductive pattern 553c**” (second outer ring portion):

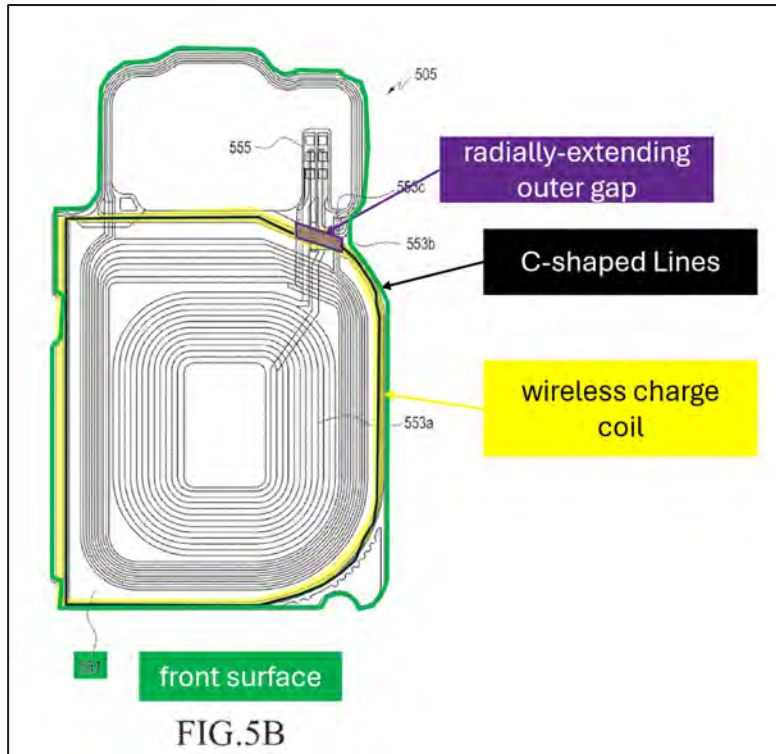

Ex1006, 19:28–34, Fig. 5 (modified to illustrate the **radially-extending outer gap**);  
Ground 3 Limitation [1f]; Ex1002 ¶309.

This is at least as much disclosure as PO contends infringes:

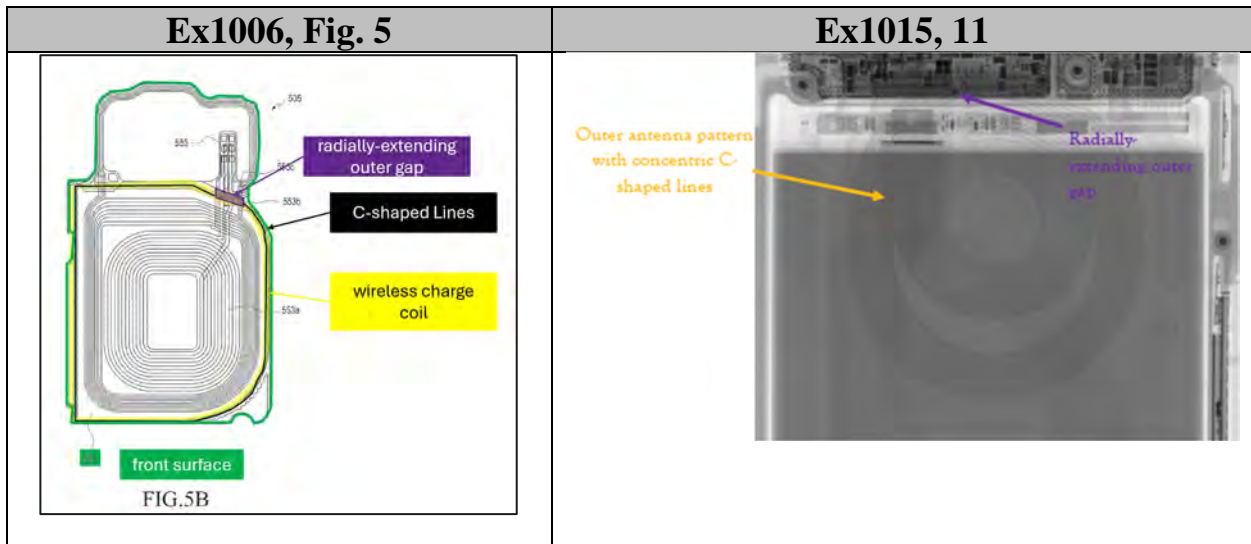

In addition, this limitation would have been obvious in view of Seong's teachings on gaps and circular lines (Ground 1 Limitation [1g]) for similar reasons as Ground 3 Limitation [1f]. Section VIII.C.1; Ex1002 ¶311.

**i. [1h]**

005Lee in view of Seong renders this limitation obvious. Ex1002 ¶¶312-317.

005Lee teaches and in view of Seong renders obvious using radially-extending inner and outer gaps. Ground 3 Limitations [1f]/[1g].

Seong teaches this limitation:

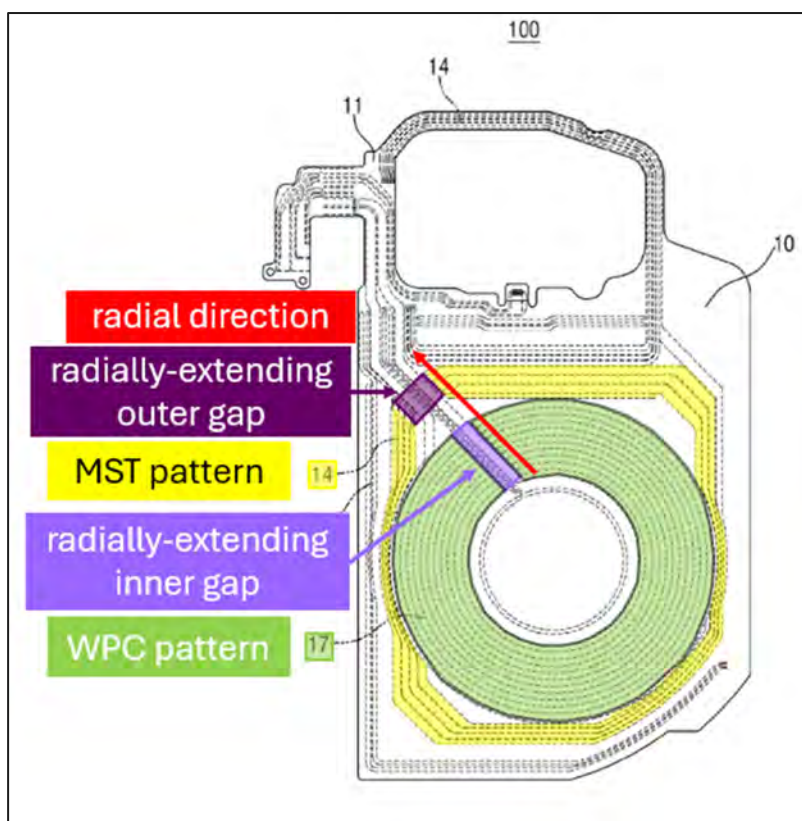

Ex1006, Fig. 5; Ex1002 ¶314; Ground 1 Limitation [1h].

It would have been obvious to incorporate Seong's coil-gaps and C-shaped lines teachings with 005Lee. Section VIII.C.1. The combination satisfies this limitation:

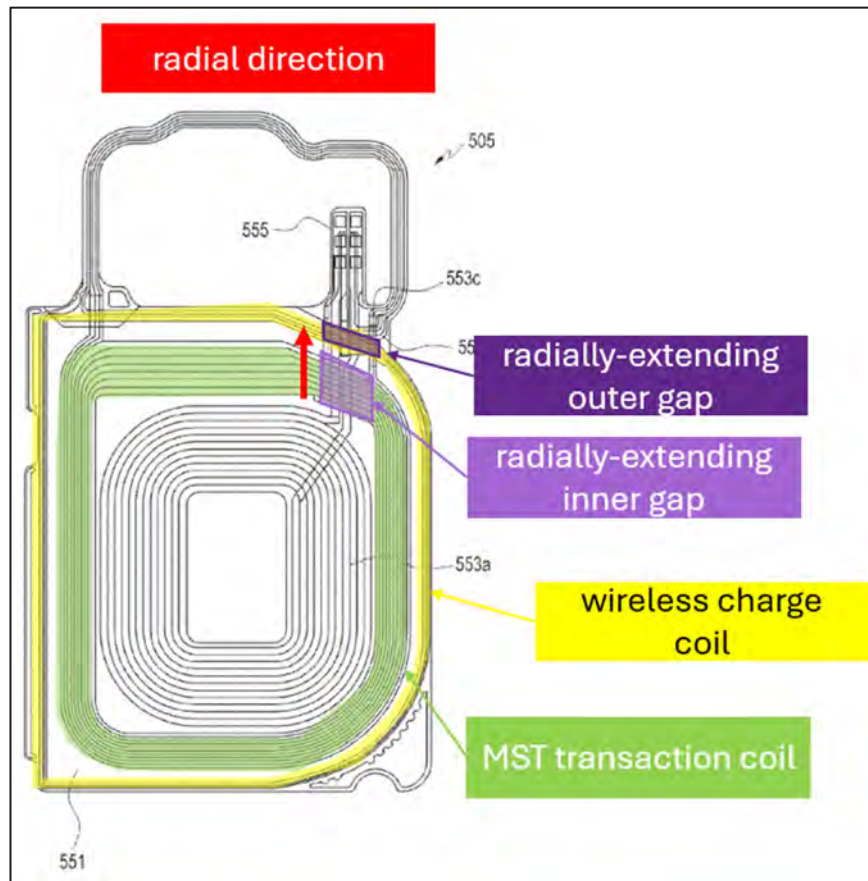

Ex1006, 19:28–34, Fig. 5; Ex1002 ¶315.

This is at least as much disclosure as PO contends infringes:

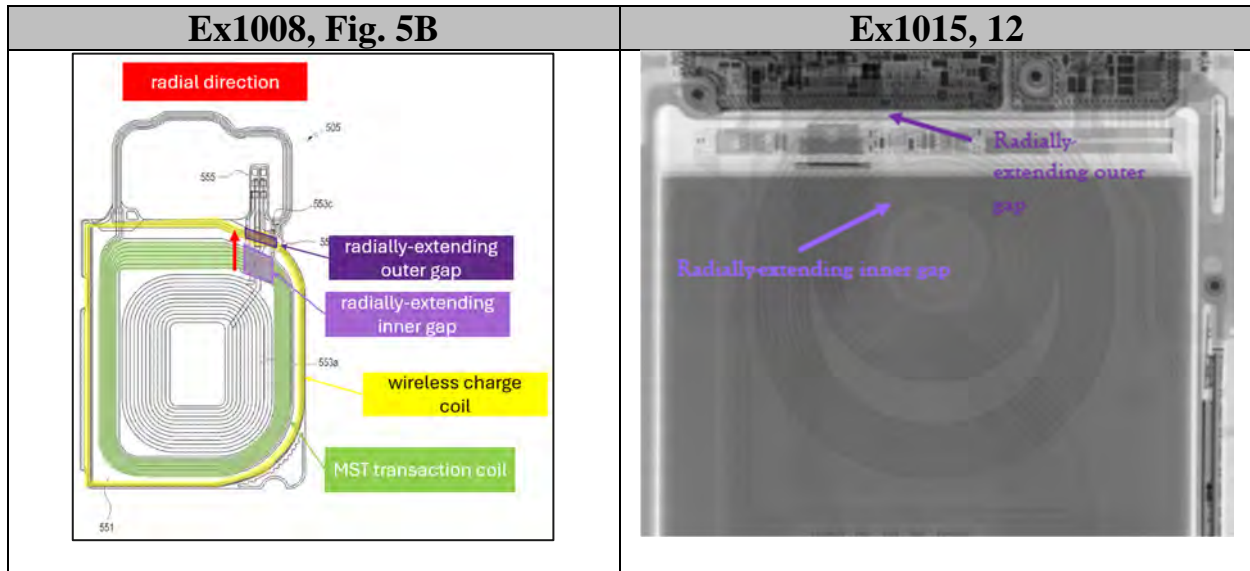

This limitation is also satisfied when 005Lee’s coils are concentric circles (Ground 3 Limitations [1f]/[1g]). Ex1006, 19:28-34; Ex1002 ¶317.

**j. [1i]**

005Lee in view of Seong renders this limitation obvious. Ex1002 ¶¶318-320.

005Lee teaches and in view of Seong renders obvious radially-extending inner and outer gaps through which extension lines extend. Ground 3 Limitations [1f]/[1g].

005Lee further teaches a “**NFC transaction coil**” and depicts, and renders obvious in view of Seong, two “**NFC transaction coil**” extension lines formed on the “**front**” surface (second major surface) that extend along the **radial direction** through both the **radially-extending inner gap** and the **radially-extending outer gap**:

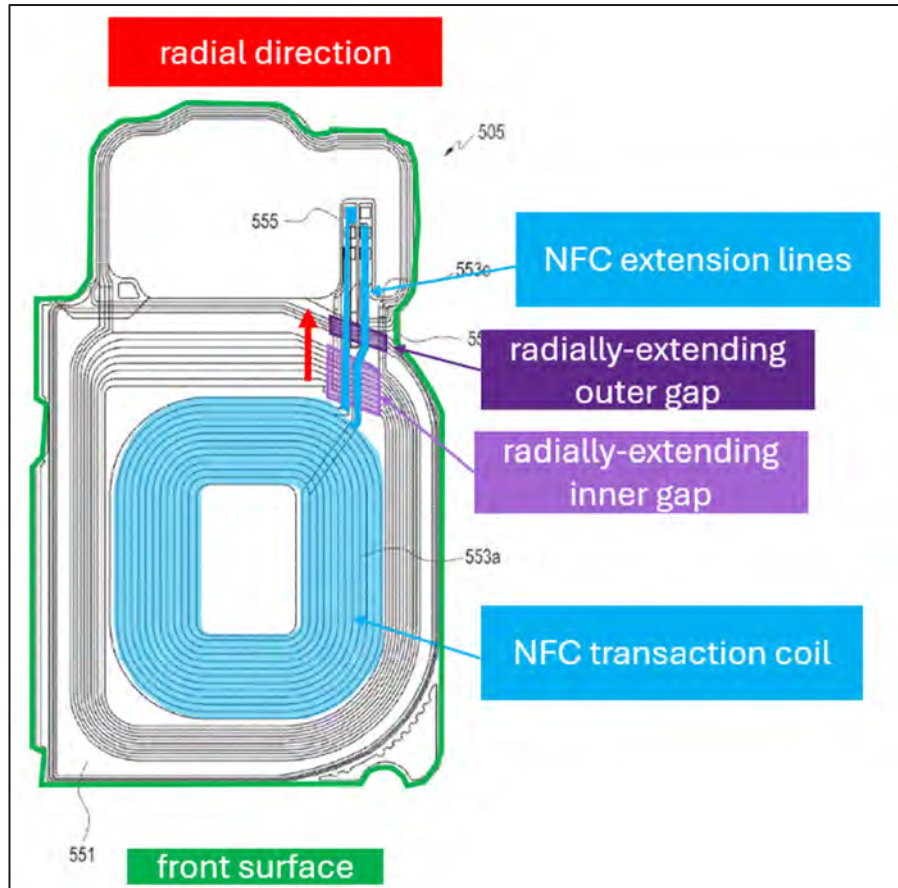

Ex1008, 19:28–30, Fig. 5B; Ex1002 ¶¶320; Section VIII.C.1.

**k. [1j]**

005Lee in view of Seong renders this limitation obvious. Ex1002 ¶¶321-323.

005Lee teaches and in view of Seong renders obvious radially-extending inner and outer gaps through which extension lines run. Ground 3 Limitations [1f]/[1g].

005Lee further teaches an **inner extension line** formed on the “**front**” surface (second major surface), and renders obvious in view of Seong that **inner extension line** extending along the **radial direction** through both the **radially-extending inner gap** and the **radially-extending outer gap**:

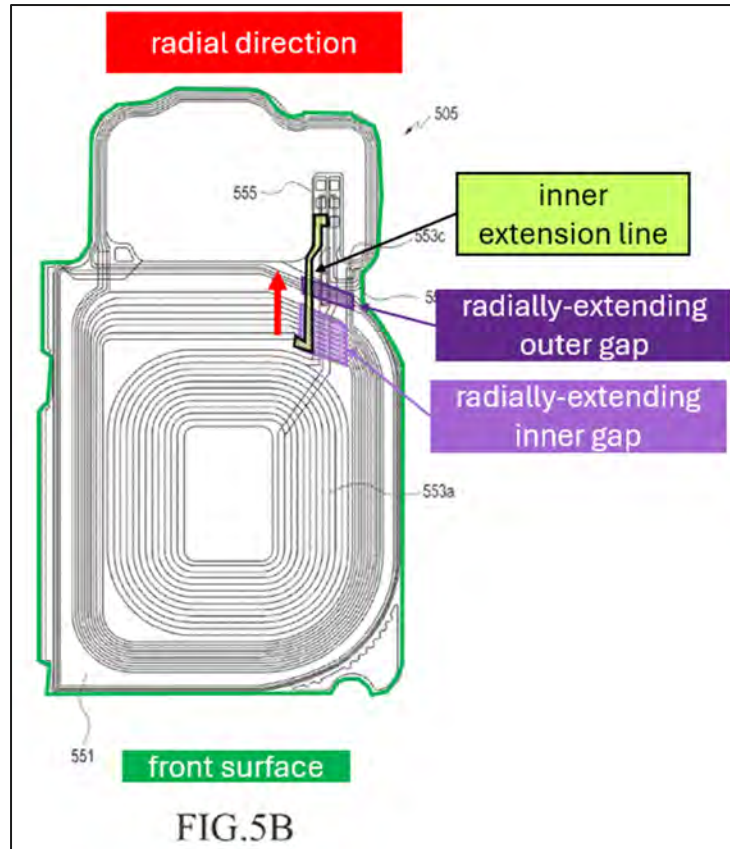

Ex1008, 17:53-63, Fig. 5B; Ex1002 ¶323; Section VIII.C.1.

I. [1k]

005Lee in view of Seong renders this limitation obvious. Ex1002 ¶¶324-326.

005Lee teaches and in view of Seong renders obvious a radially-extending outer gap through which extension lines run. Ground 3 Limitation [1g].

005Lee further teaches an **outer extension line** formed on the “**front**” surface (second major surface) that connects the **wireless charge coil 553c** to “connection piece 555” and renders obvious in view of Seong that **outer extension line** extending along the **radial direction** through the **radially-extending outer gap**:

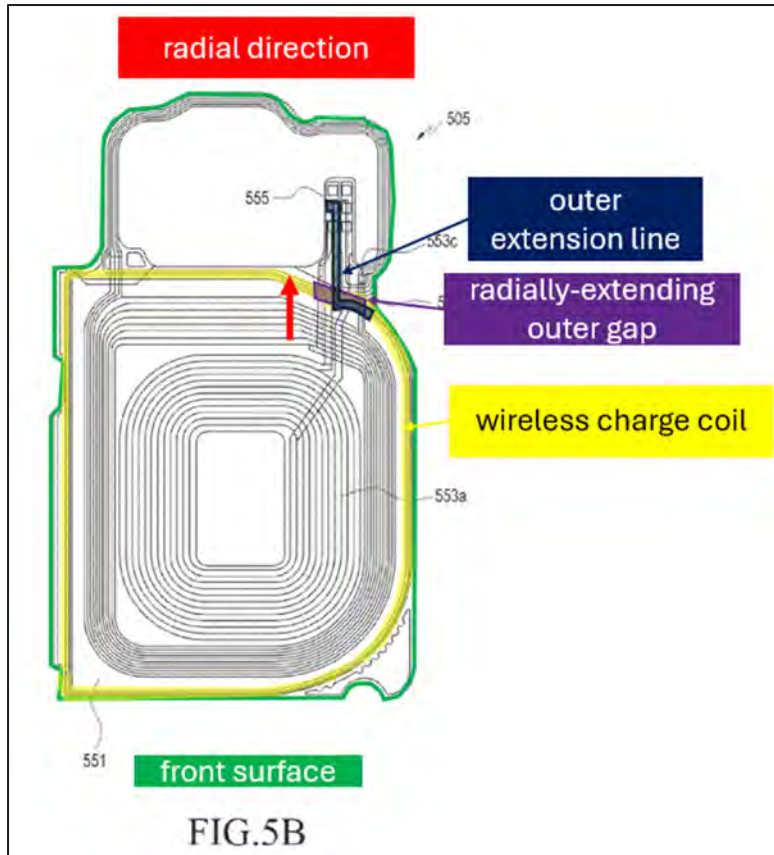

Ex1008, 17:53–63, Fig. 5B; Ex1002 ¶¶326; Section VIII.C.1.

m. [1]

005Lee teaches this limitation. Ex1002 ¶¶327-328.

005Lee teaches the two “NFC transaction coil” extension lines, the **inner extension line**, and the **outer extension line** are extending substantially in parallel:

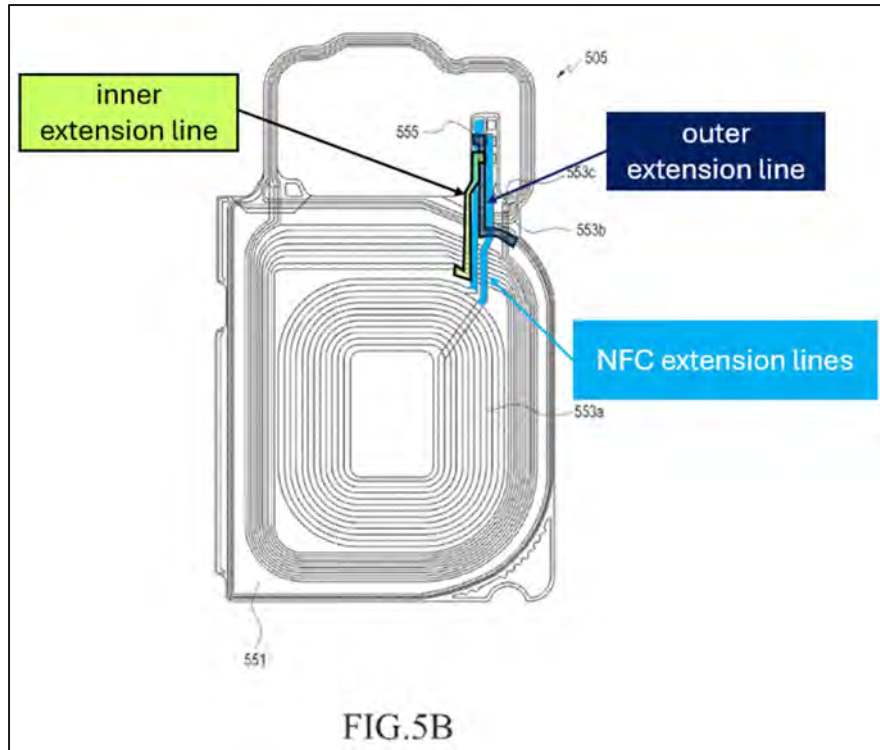

Ex1008, Fig. 5B; Ex1002 ¶328.

n. [1m]

005Lee in view of Seong renders this limitation obvious. Ex1002 ¶¶329-331.

The 005Lee-Seong combination renders obvious each of the two “**NFC transaction coil**” extension lines, the **inner extension line**, and the **outer extension line** formed on the “**front**” surface (second major surface) overlaps the outer coil formed on the first outer ring portion (Seong’s MST pattern) on the first major surface (005Lee’s “**back**” surface (first major surface)):

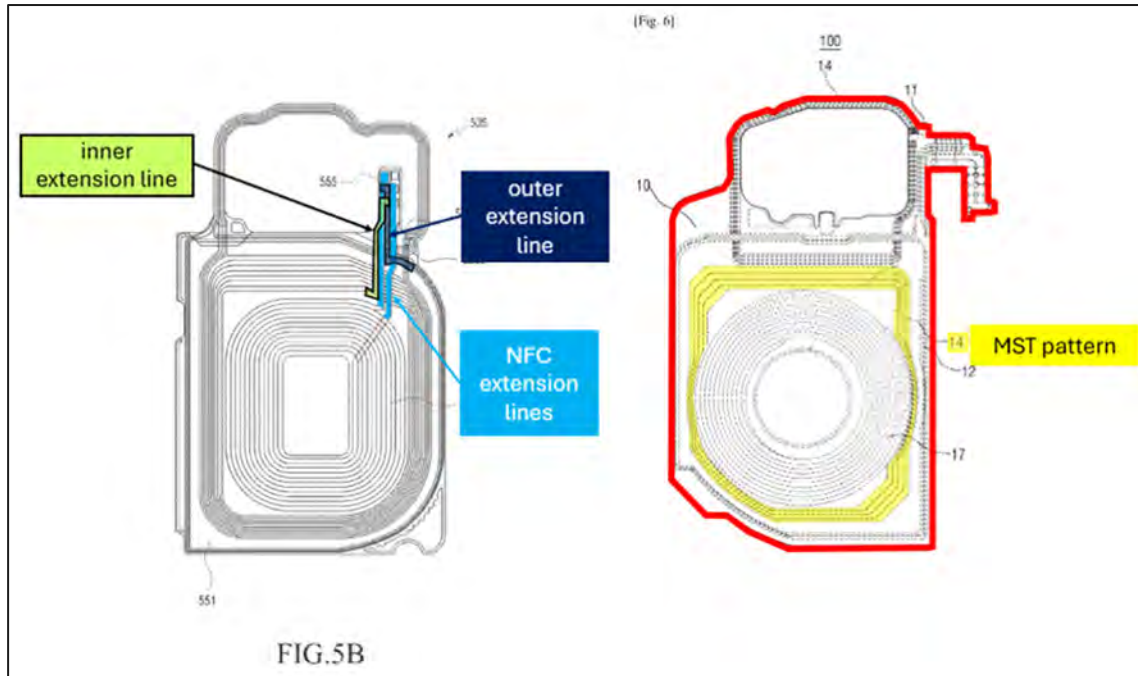

Ex1008, Fig. 5B; *id.*, Figs. 4A-4B, 43D; Ex1006 ¶64, Fig. 6; Ground 3 Limitation [1a]; Ex1002 ¶330.

Further, a POSA would have found an arrangement with an overlap portion to be obvious. Ex1002 ¶331. 005Lee teaches shaping its coils in concentric circles. Ex1008, 19:28-34. A POSA would have found it obvious to shape 005Lee's coils on both surfaces in tight, concentric circles to maximize space efficiency and reduce unused substrate space, and when so shaped, the combination satisfies this limitation. Ex1002 ¶331.

**o. [1n]**

The 005Lee-Seong-Cho combination renders this limitation obvious. Ex1002 ¶¶332-334.

Cho teaches electrically connecting inner and outer coils in parallel. Ex1002 ¶333. Cho’s “wireless communication coil” comprises a “first coil portion” and a “second coil portion[,]” which “may be connected in series or in parallel.” Ex1010 ¶¶90, 91.

It would have been obvious to incorporate Cho’s parallel-electrical-connection teachings with the combined 005Lee-Seong teachings to electrically connect 005Lee’s MST and wireless charge coils (inner and outer coils) in parallel. Section VIII.C.1; Ex1002 ¶334.

### 3. [2]

The 005Lee-Seong-Cho combination renders claim 1 obvious and further renders obvious the remaining limitations of this claim. Ex1002 ¶¶335-339.

005Lee teaches forming antenna patterns on opposing substrate surfaces. Ground 3 Limitations [1a]-[1e]. 005Lee further teaches using “a connection element” that “electrically interconnect[s]” separation components, which “can be a passive element, such as an inductor or a capacitor, or a structure that contains a conductive material.” Ex1008, 21:39-51.

Seong teaches electrically connecting the first and second antenna patterns on opposing substrate surfaces through a plurality of vias. Ground 1 Claim [2].

Cho also teaches electrically connecting the first and second antenna patterns on opposing substrate surfaces through a plurality of vias. Ex1002 ¶338. Cho

teaches that “wireless charging coil 111 on said one surface 11 of the substrate may be connected through via holes to the wireless charging coil 112 formed on the other surface 12 of the substrate.” Ex1010 ¶¶66-67, Cls. 2, 10.

It would have been obvious to incorporate Seong’s and Cho’s via teachings with 005Lee, satisfying the limitations of this claim. Section VIII.C.1; Ex1002 ¶339.

**4. [3]**

The 005Lee-Seong-Cho combination renders claim 1 obvious and further renders obvious the remaining limitations of this claim. Ex1002 ¶¶340-342.

005Lee teaches and the 005Lee-Seong-Cho combination renders obvious a **first inner extension** line on the “**front**” surface (second major surface). Ground 3 Limitation [1j].

005Lee further teaches and the 005Lee-Seong-Cho combination renders obvious, a **second inner extension line** formed on the “**front**” surface (second major surface) that extends along the **radial direction** through the **radially-extending outer gap**:

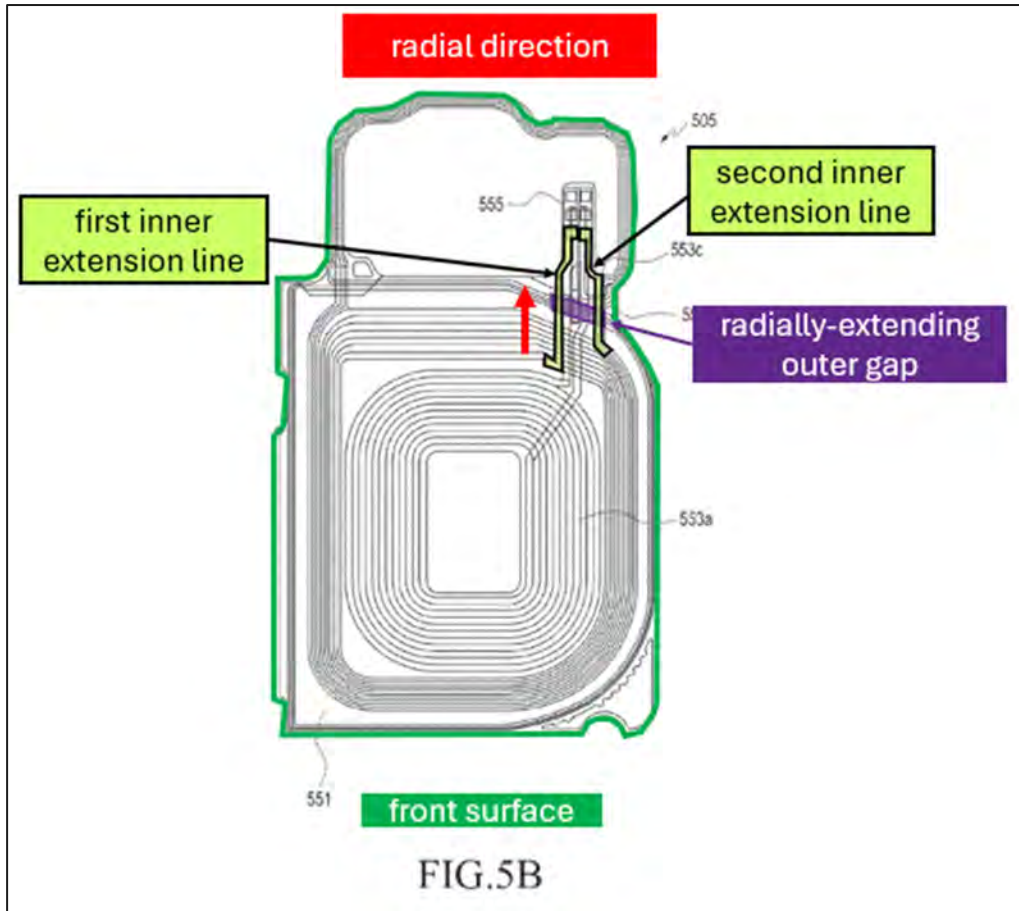

Ex1008, 17:53-63, Fig. 5B; Ex1002 ¶¶341-342; Section VIII.C.1.

5. [4]

The 005Lee-Seong-Cho combination renders claim 1 obvious and further renders obvious the remaining limitations of this claim. Ex1002 ¶¶343-345.

Seong's "WPC antenna" on the "bottom" surface (inner coil) includes a wire line having a width different from that of a wire line of "MST antenna" on the "bottom" surface (outer coil):

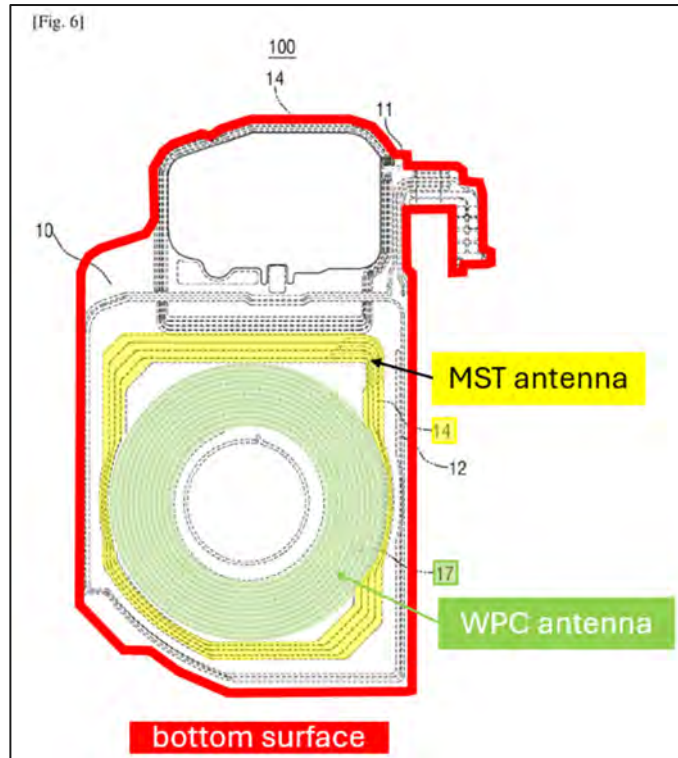

Ex1006 ¶64, Fig. 6; Ground 1 Claim [4]; Ex1002 ¶344. Seong’s coil’s wire lines’ widths may vary, as Seong Figure 6 depicts. Ex1006 ¶63; Ex1002 ¶344.

It would have been obvious to incorporate Seong’s bottom-surface coil-pattern teachings with 005Lee. Section VIII.C.1; Ex1002 ¶345.

## 6. [5]

The 005Lee-Seong-Cho combination renders claim 1 obvious and 005Lee further teaches the remaining limitations of this claim. Ex1002 ¶¶346-349.

Seong’s “WPC antenna” on the “bottom” surface (inner coil) has a first number of turns that is greater than that of “MST antenna” on the “bottom” surface (outer coil):

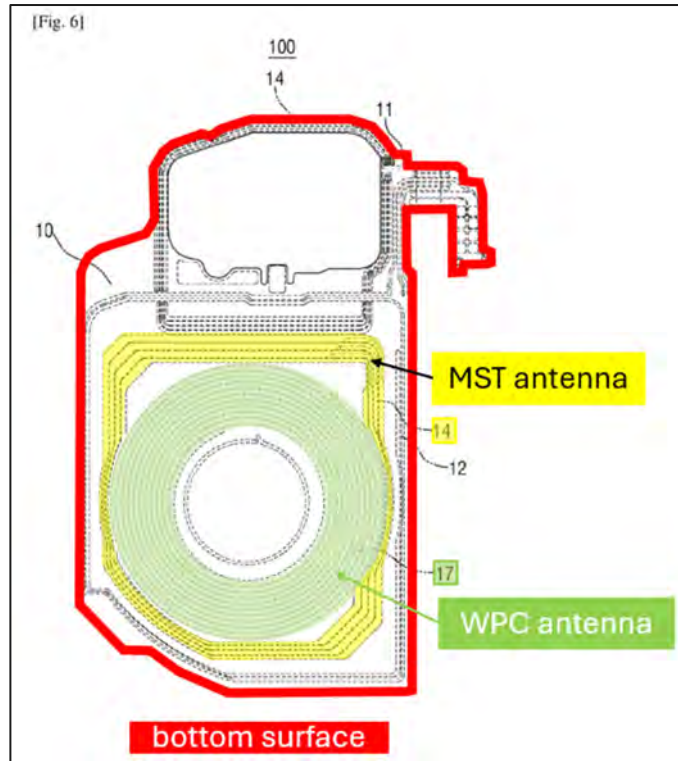

Ex1006 ¶64, Fig. 6; Ground 1 Claim [5]; Ex1002 ¶347.

As shown above, Seong depicts “**WPC antenna**” having approximately 11 turns, and “**MST antenna**” having approximately 4 turns. Ex1002 ¶348. Seong teaches antenna pattern “shape” and “arrangement” “may be varied,” including the number of coil turns. Ex1006 ¶63; Ex1002 ¶348.

It would have been obvious to incorporate Seong’s bottom-surface coil-pattern teachings with 005Lee. Section VIII.C.1.

## 7. [6]

The 005Lee-Seong-Cho combination renders claim 1 obvious and further renders obvious the remaining limitations of this claim. Ex1002 ¶¶350-354.

Seong teaches a “smartphone[]” comprising a “battery” and an “antenna structure” including coils “provid[ing] ... wireless charging.” Ex1006, Abstract, ¶¶3, 5, 12, 28, 53, 64, 75, 77, 80, Abstract. Seong also teaches its “WPC antenna” (inner coil) is a “Wireless Power Charge” coil (i.e., it is configured for wireless battery charging). Ex1006 ¶2.

Further, 005Lee teaches a smartphone comprising “battery 443”:

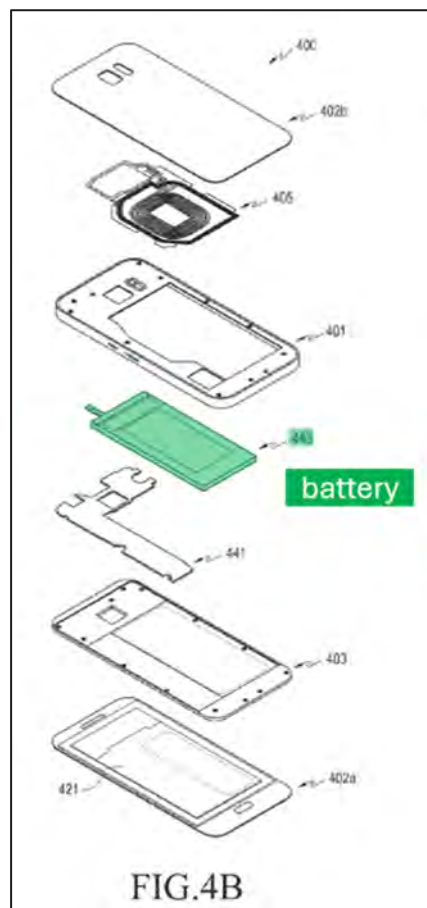

Ex1008, 6:23, 15:18-31, Figs. 4A, 4B; Ex1002 ¶352.

005Lee teaches **MST coil 553b** and **wireless charge coil 553c** are configured for wireless charging. Ex1002 ¶353. “Each of the first to third conductive patterns

553a, 553b, and 553c can be connected to ... the wireless charge module ... so as to conduct ... the wireless charge function.” Ex1008, 19:18-25. 005Lee teaches “wireless charge module 1057a can wirelessly receive power through the conductive pattern unit 1005 and can charge a battery (e.g., the battery 443 of FIG. 4A),” and “can be individually or selectively connected to each of the first to third conductive patterns” to “connect at least one of the first to third conductive patterns ... to the wireless charge module.” *Id.*, 22:46-58.

A POSA would have thus understood that, in the combined 005Lee-Seong teachings, it would have been obvious to configure both the inner coil (Seong’s “WPC antenna”) and the outer coil (Seong’s “MST antenna”) for wireless battery charging, as taught by 005Lee. Ex1008, 19:18-25; Ex1002 ¶354.

## **IX. SECONDARY CONSIDERATIONS**

Petitioners are unaware of any secondary considerations of non-obviousness.

## **X. MANDATORY NOTICES UNDER 37 C.F.R. §42.8**

### **A. Real Parties-in-Interest**

Petitioners identify themselves as the real parties-in-interest.

### **B. Related Matters**

To the best of Petitioners’ knowledge, apart from the above-mentioned litigation, *AQ Corporation v. Samsung Electronics Co., Ltd. et al.*, Case No. 2:25-cv-01012-JRG (EDTX), the ’011 Patent has not been involved in any litigation, *inter partes* or post-grant review prior to this proceeding.

**C. Lead and Backup Counsel, Service, and Power of Attorney**

Lead Counsel	Back-Up Counsel
Robert A. Appleby, P.C. Reg. No. 40,897 robert.appleby@kirkland.com <u>Postal and Hand-Delivery Address</u> Kirkland & Ellis LLP 601 Lexington Avenue New York, NY 10022 Telephone: +1 212 446 4800 Facsimile: +1 212 446 4900	F. Christopher Mizzo Reg. No. 73,156 chris.mizzo@kirkland.com <u>Postal and Hand-Delivery Address</u> Kirkland & Ellis LLP 1301 Pennsylvania Avenue, N.W. Washington, D.C. 2004 Telephone: +1 202 389 5000 Facsimile: +1 202 389 5200  Todd Baker Reg. No. 45,465 todd.baker@kirkland.com <u>Postal and Hand-Delivery Address</u> Kirkland & Ellis LLP 1301 Pennsylvania Avenue, N.W. Washington, D.C. 2004 Telephone: +1 202 389 5000 Facsimile: +1 202 389 5200

Petitioners concurrently submit a Power of Attorney, 37 C.F.R. § 42.10(b), and consent to electronic service at Samsung-AQ@kirkland.com.

**XI. PAYMENT OF FEES UNDER 37 C.F.R. §42.103**

Petitioners concurrently electronically submit the required fees for this Petition. The Board is authorized to charge Deposit Account No. 506092 for any fee deficiency.

Petition for *Inter Partes* Review of U.S. Patent No. 11,303,011

Date: January 26, 2026

Respectfully submitted,

/s/ Robert A. Appleby

Robert A. Appleby, P.C.  
Reg. No. 40,897

*Attorneys for Petitioner*

**CERTIFICATE OF COMPLIANCE**

This Petition complies with the type-volume limitations as mandated in 37 C.F.R. § 42.24, totaling 12,797 words. Counsel has relied upon the word count feature provided by Microsoft Word.

/s/ Robert A. Appleby  
Robert A. Appleby (Reg. No. 40,897)

**CERTIFICATE OF SERVICE**

Pursuant to 37 C.F.R. §§ 42.6(e)(4)(i) *et seq.* and 42.105(b), the undersigned certifies that a copy of the foregoing document with the accompanying Exhibits listed in Petitioners' Exhibit List was caused to be served by Federal Express, costs prepaid, to Patent Owner at the following address of record:

KASHA LAW LLC  
14532 Dufief Mill Road  
North Potomac, MD 20878

A copy was also served via electronic mail and FTP on the attorneys of record in the following related matter, *AQ Corporation v. Samsung Electronics Co., Ltd. et al.*, Case No. 2:25-cv-01012-JRG (EDTX):

Nicholas F. Lenning  
K&L GATES LLP  
925 Fourth Avenue, Suite 2900  
Seattle, Washington 98104  
Telephone: (206) 623-7580  
Fax: (206) 623-7022  
nicholas.lenning@klgates.com

James A. Shimota  
Austin C. Holler  
Laurel W. Salisbury  
Devdhi Kasana  
K&L GATES LLP  
70 West Madison Street, Suite 3300  
Chicago, IL 60602  
Telephone: (312) 372-1121  
Fax: (312) 827-8000  
jim.shimota@klgates.com  
austin.holler@klgates.com  
laurel.salisbury@klgates.com

Petition for *Inter Partes* Review of U.S. Patent No. 11,303,011

devdhi.kasana@klgates.com

Andrea L. Fair  
MILLER FAIR HENRY PLLC  
1507 Bill Owens Parkway  
Longview, TX 75604  
Telephone: (903) 757-6400  
Fax: (903) 757-2323  
andrea@millerfairhenry.com

/s/ Robert Leonard  
Robert Leonard, Case Manager  
Kirkland & Ellis LLP