



TRANSLATION CERTIFICATION

Date: December 10, 2025

To whom it may concern:

I, Summer Xia, a translator fluent in the Chinese and English languages, on behalf of Morningside, do solemnly and sincerely declare that the following is, to the best of my knowledge and belief, a true and correct translation of the document(s) listed below in a form that best reflects the intention and meaning of the original text.

The document is designated as:

- CN101139007A

Signature

Summer Xia

Print

QUESTEL CONFIDENTIAL

4001 S 700 East, Suite 500 #B17
Salt Lake City, UT 84107



[12] INVENTION PATENT
APPLICATION PUBLICATION

[21] Application No.: 200710119800.5

[43] Publication Date: March 12, 2008

[11] Publication No.: CN 101139007A

[22] Filing Date: July 31, 2007

[21] Application No.: 200710119800.5

[71] Applicant: Beijing Institute of Technology
Address: 100081 No. 5 Zhongguancun South Street, Haidian District, Beijing

[72] Inventors: Fu Mengyin; Wang Meiling;
Yang Yi; Fu Yuan; Liu Tong;
Liu Wei

[74] Patent Agency: Beijing Institute of Technology Patent Center
Agents: Zhang Liping

Claims: 5 pages; Description: 10 pages;
Drawings: 4 pages.

[54] Title:

UNDERWATER CLEANING ROBOT

[57] ABSTRACT

The present invention discloses an underwater cleaning robot. The robot can operate in two operating modes: remote control and autonomous control, and includes a drainage mechanism, a cleaning and moving platform, and a control system. Through coordinated division of labor among the drainage mechanism, the cleaning and moving platform, and the control system, the robot can perform cleaning work autonomously or remotely on underwater horizontal, vertical, or inclined surfaces. The present invention has the characteristics of light weight, large capacity, compact and reasonable mechanical structure, and good practicability, stability, energy conservation, economical efficiency, and universality, and is a robot that can be used for underwater cleaning of the bottom and walls of a swimming pool.

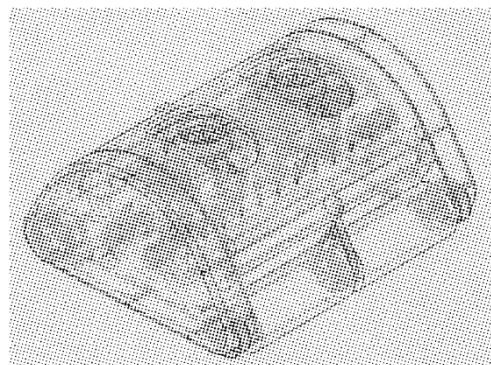

1. An underwater cleaning robot, comprising a drainage mechanism, a cleaning and moving platform, and a control system, wherein the drainage mechanism comprises a drainage device, a water flow channel (24) formed by a sealed drive control enclosure and an inner wall of a robot housing, a water filtration screen (23), and a water inlet and a backflow prevention device (25); the cleaning and moving platform comprises the robot housing (1), a cleaning drive wheel (3), a synchronous belt gear (5), and a synchronous drive belt (4); and the control system comprises a central processing unit, a monitoring camera, an image acquisition card, an inertial navigation component, a remote control signal interface, a motor driver, a control system enclosure (8), a cleaning drive wheel DC motor (7), a drain port drive servo motor (16), a drainage propeller high-speed DC motor (14), the sealed drive control enclosure, and a control and power management system.
2. The underwater cleaning robot according to claim 1, wherein the underwater cleaning robot is equipped with a plurality of independent drainage devices and coordinates movements of the drainage devices; a drain port fixing bracket (13) is fixed to the top of the sealed drive control enclosure; the water flow channel (24) comprises space defined by an outer wall of the sealed drive control enclosure and the inner wall of the robot housing (1); the water filtration screen (23) is fixed to the water flow channel (24), and divides, together with the inner wall of the robot housing (1) and the sealed drive control enclosure, the water flow channel (24) into two portions; the water inlet (26) and the backflow prevention device (25) are located on a bottom surface of a robot main shell (20), the backflow prevention device (25) is divided into two portions, which are fixed via a shaft bracket, located above the water inlet (26), and capable of rotating around a shaft; when water enters the water flow channel (24) of the robot, the two portions of the backflow prevention device (25) rotate around the shaft due to the effect of a water flow, and the water inlet (26) is opened; and when water stops entering, the backflow prevention device (25) returns to a closed state, preventing water in the water flow channel (24) from flowing back.
3. The underwater cleaning robot according to claim 1, wherein the drainage mechanism uses the cleaning and moving platform as a carrier, and moves in coordination with the cleaning and moving platform; the cleaning and moving platform comprises the robot housing (1), cleaning drive wheels (3), synchronous belt gears (5), and synchronous drive belts (4); and the robot housing (1) comprises a robot top cover (18), a robot side wall (20), and a robot main shell (19), and the robot housing is made of a one-piece molded polymer material; the cleaning drive wheels (3) comprise four independently driven cylindrical wheel hubs, outer layers of the wheel hubs are configured with wheel surfaces of different materials according to cleaning requirements, and the four cleaning drive wheels (3) are arranged in pairs, and are assembled with and connected to the robot via the robot side wall, and a cleaning drive wheel lateral bracket (21) and a cleaning drive wheel central bracket (22) of the robot main shell; and for the synchronous belt gears (5) and the synchronous drive belts (4), two synchronous belt gears (5) and one synchronous drive belt (4) constitute one group, and are mounted between a side panel of the robot main shell (19) and the robot side wall (20), wherein one synchronous belt gear (5) is connected to one drive DC motor (7), the other synchronous belt gear (5) is connected to one cleaning drive wheel (3), and the two synchronous belt gears (5) are connected via power transmission by the synchronous drive belt (4).
4. The underwater cleaning robot according to claim 1, characterized in that the control system comprises the central processing unit, the monitoring camera, the image acquisition card, the inertial navigation component,

the remote control signal interface, motor drivers, the control system enclosure (8), the cleaning drive wheel DC motor (7), the drain port drive servo motor (16), the drainage propeller high-speed DC motor (14), the sealed drive control enclosure, and the control and power management system; a chip of the central processing unit, the image acquisition card, the inertial navigation component, and the remote control signal interface constitute an input portion of the control system; the chip of the central processing unit and a motor driver constitute an output portion of the control system; a motor driver and the cleaning drive wheel DC motor (7) constitute a cleaning drive execution layer of the control system; a motor driver and the drain port drive servo motor (16) constitute a rotation execution layer of a drain port (10); a motor driver and the drainage propeller high-speed DC motor (14) constitute a drive execution layer of a propeller (11); the monitoring camera (2) is installed on two front panels of the robot main shell (19), and the monitoring camera (2) and the image acquisition card constitute an environment perception layer of the control system; the inertial navigation component is installed on the robot control system enclosure (8) to constitute an attitude positioning layer of the control system; the control system enclosure (8) houses the control system comprising the central processing unit, the image acquisition card, the inertial navigation component, the remote control signal interface, a power management module, and the motor drivers, and is provided with both a power input interface and a rechargeable battery box, allowing the robot to be powered either externally or by the battery box for a short period of time; the control system enclosure is fixed to the bottom of the sealed drive control enclosure; the power management module is configured to stabilize voltage and current and monitor overcurrent and overload of a robot circuit, protecting the control system of the robot; the cleaning drive wheel DC motor (7) is equipped with a reduction gearbox and an encoder, and is fixed to a side wall of the sealed drive control enclosure and a side wall of the robot main shell (19) via front flanges, to drive the cleaning drive wheel (3); the drain port drive servo motor (16) is fixed to the drain port fixing support (12), to drive the drain port (10) and the drain port bracket (12) to rotate around a drain port drive shaft (17); the drainage propeller high-speed DC motor (14) is fixed to a drainage propeller bracket (15), to drive the drainage propeller (11) to rotate; both the cleaning drive wheel DC motor (7) and the drainage propeller high-speed DC motor (14) are equipped with encoders and configured to implement motor servo control with the respective motor drivers; the sealed drive control enclosure comprises a sealed enclosure upper cover and a main enclosure body, and the sealed enclosure upper cover comprises a drain port sliding groove (9) with a waterproof function; the sealed drive control enclosure is installed on and fixed to the interior of the robot main shell (19) via side walls at two ends of the robot main shell (19), to sealingly enclose the control system components comprising the control system enclosure (8), the cleaning drive wheel DC motor (7), the drain port drive servo motor (16), and the drainage propeller high-speed DC motor (14); the sealed drive control enclosure is made of a one-piece molded polymer material, and has waterproof properties; the control and power management system comprises a control signal buoyant antenna (27), a control signal buoyant antenna cable (35), a signal relay and cable manager (28), a signal and power cable (33), a cable guide pulley assembly (32), and a cable counterweight ring (34); the signal relay and cable manager (28) comprises a signal relay and a cable manager (29), and is fixed to a surface at a poolside via a manager bracket (30); the control signal buoyant antenna (27) is installed on and connected to an antenna interface of the signal relay and cable manager (28), to receive a control signal from a control keyboard (31), and the control signal is relayed and transmitted to the remote control signal interface of the underwater cleaning robot via the signal and power cable (33);

the signal relay and cable manager (28) is equipped with an external AC power supply and an AC-to-DC converter, and is connected to a power input interface of the underwater cleaning robot via the signal and power cable (33) to power the robot; the signal relay and cable manager (28) controls a cable winding/unwinding motor via a motor driver, under the command of the central processing unit of the underwater cleaning robot, to execute winding and unwinding of the cable; the signal relay of the signal relay and cable manager (28) implements a connection to the control signal buoyant antenna, and sends data to the robot; the cable manager (29) of the signal relay and cable manager (28) comprises the cable winding/unwinding motor with an encoder, which is controlled by the central processing unit of the robot, to implement a cable winding/unwinding function; the signal and power cable (33) comprises a control signal line and a power line, and density of the cable is smaller than that of water, and configured to be changed by installing the cable counterweight ring (34), to adjust a suspension state of the cable in water; the cable counterweight ring (34) is made of a high-density polymer material, and is tightly interlocked with the cable, and has an adjustable installation position; the control signal buoyant antenna (27) comprises a control signal antenna and a buoyant carrier, has a density far lower than that of water, and floats on a water surface to wirelessly communicate with the control keyboard (31); the control signal buoyant antenna is configured to directly communicate with the remote control signal interface of the robot via the control signal buoyant antenna cable (35), or is installed on and fixed to the signal relay and cable manager (28) configured to indirectly communicate with the robot via the signal and power cable (33); the signal relay and cable manager (28) is capable of being connected to an external display apparatus, to display an operating condition and relevant performance indicators of the underwater cleaning robot; and when the robot operates with the cable, the cable guide pulley assembly (32) is installed at a corner of the poolside, comprises a fixed pulley and a fixed pulley seat rotation shaft, and is configured to enable rotation of the fixed pulley itself and rotation of a fixed pulley assembly around the fixed pulley seat rotation shaft.

5. The underwater cleaning robot according to claim 1, wherein operating modes comprise manual cleaning and autonomous cleaning; in the manual mode, a control signal is sent by manual operation using the control keyboard, to directly or indirectly control the underwater cleaning robot via the control signal buoyant antenna; in the autonomous mode, a control signal is generated by the central processing unit based on information from the environment perception layer and the attitude positioning layer, in combination with a preset cleaning task, a path and an action are autonomously planned, and the execution layer of the robot is driven, to complete an underwater cleaning task; during long-term global cleaning, the robot operates with the cable, and the signal relay and cable manager (28) and the signal and power cable (33) are used; and during short-term local cleaning, the robot is powered by the battery box without using the signal relay and cable manager (28) and the signal and power cable (33) but using the control signal buoyant antenna (27) and the control signal buoyant antenna cable (35), with a relatively short operating time.

6. The underwater cleaning robot according to claim 1, wherein the underwater cleaning robot controls an action of the robot based on a control instruction issued by the central processing unit; in the drainage mechanism, the drainage propeller high-speed DC motor (14), under the control of the motor driver thereof, drives the drainage propeller (11) to rotate at a set rotational speed, to drain water from the water flow channel (24) of the robot, so that a high negative pressure is formed in the water flow channel, and pool water at the bottom of the robot is sucked into the water flow channel (24) through the water inlet; debris in the water flow is filtered by the water filtration screen (23),

and then clean water is drained out; in addition, the motor driver of the drainage propeller high-speed DC motor is configured to determine density of the dirt in the water flow channel (24) by monitoring the motor rotational speed and current, and issues a dirt saturation alarm when the dirt reaches a certain density; the drain port drive servo motor (16) is controlled by the motor driver thereof, to drive the drain port bracket (12) to rotate around the drain port drive shaft (17) along the drain port sliding groove (9), to change a drainage direction; the backflow prevention device (25) is installed on the water inlet (26), when water flows in through the water inlet, the backflow prevention device (25) opens due to an acting force of the water, and when the water stops flowing in, the backflow prevention device (25) closes due to the disappearance of the acting force of the water, thereby preventing the debris in the water flow channel (24) from flowing out; and in the cleaning and moving platform, four independent cleaning drive wheels (3) are controlled by their respective motor drivers, and are configured to move independently, and implement tasks of the robot including moving forward, moving backward, turning, and scrubbing for cleaning through different wheel speed combinations.

7. The underwater cleaning robot according to claim 1, wherein when the robot is powered with the cable and executes a cleaning task, the robot performs dead reckoning by using the inertial navigation component and the cleaning drive wheel (3) to obtain robot position information, and then the central processing unit controls the cable winding/unwinding motor to wind or unwind the signal and power cable (33) based on an actual length requirement; a proper position is selected for installing the cable counterweight ring (34) based on a depth of a swimming pool and an actual requirement, to adjust the suspension state of the cable in water; the signal relay and cable manager (28) guides winding or unwinding of the cable via the cable guide pulley assembly (32); when the robot executes a task underwater without the cable, the control signal buoyant antenna (27) is connected to the robot via the control signal buoyant antenna cable (35), to receive a remote control signal, and control the movement of the robot; during autonomous cleaning, a swimming pool cleanliness image threshold is set, the robot uses the monitoring camera (2) to capture an image of the bottom of the swimming pool, determines a cleanliness level of the bottom of the swimming pool by comparing the image with the threshold, and plans a cleaning movement, and then adjusts operating conditions of the four cleaning drive wheels 3 and the drainage devices to complete the cleaning task; in addition, by adjusting a drainage direction of a drain port (10) and a rotational speed of the drainage propeller (11), the cleaning intensity is changed to improve operating efficiency of the robot; and a same control strategy is used for cleaning a vertical pool wall.

8. The underwater cleaning robot according to claim 1, wherein due to the high negative pressure in the water flow channel (24) of the robot and the acting force of the drainage mechanism, the robot is attached to the vertical wall of the swimming pool for cleaning, thereby implementing a vertical wall-following movement of the robot.

9. The underwater cleaning robot according to claim 1, wherein a drain port (10) is configured to move along the drain port sliding groove (9), affecting movement, cleaning, turning, and vertical wall-following movement of the robot; a plurality of drain ports (10) coordinate to move or position along the drain port sliding groove (9), and the drainage directions of the drain ports (10) are changed, to produce different acting forces on movements of the robot; when the robot is in a floating state in water, an attitude of the robot in water is adjustable by adjusting the drainage direction and drainage intensity of the two drain ports (10); and when the robot climbs on a wall, a chassis is lifted up due to factors including a swimming pool step,

so that four cleaning drive wheels (3) of the robot fail, and in this case, a position of a drain port is adjusted to provide a propelling force for the robot to return to a normal operating condition.

10. The underwater cleaning robot according to claim 1, wherein after a cleaning task is completed, the water flow channel (24) of the underwater cleaning robot is configured to be cleaned by opening the robot top cover (18) and the water filtration screen (23).

UNDERWATER CLEANING ROBOT**Technical Field**

The present invention relates to a robot, and in particular, to an underwater cleaning robot which is used for cleaning underwater environments, has an autonomous moving function, can be used for cleaning underwater horizontal surfaces, vertical surfaces and inclined surfaces through remote control or autonomous control, and can replace humans to autonomously complete underwater cleaning work.

Background

Swimming has a history of thousands of years; with the accelerated pace of modern life and improved living standards, it has become an important form of exercise for physical fitness, leisure, and entertainment of people. The cleanliness and sanitation of a swimming pool directly impacts an exercise situation and an exercise result of a swimmer. Therefore, it is very important to keep water and walls of the swimming pool clean and hygienic. Cleaning methods for swimming pools vary depending on the forms and scales of the swimming pools. At present, both manual cleaning and automatic water circulation methods result in significant waste or redundancy in water resources or other energy resources, and labor, increasing swimming pool maintenance costs and directly increasing swimming expenses of swimmers. Therefore, an automatic underwater cleaning device is needed to solve this problem.

Summary of the Invention

An objective of the present invention is to provide an underwater robot which can be flexible, maneuverable, economical and energy-saving, and has a plurality of operating modes, so as to better complete underwater cleaning work.

The present invention discloses an underwater cleaning robot, including a drainage mechanism, a cleaning and moving platform, and a control system.

The drainage mechanism in the present invention includes a drainage device, a water flow channel formed by a sealed drive control enclosure and an inner wall of a robot housing, a water filtration screen, and a water inlet and a backflow prevention device. The drainage device includes a drain port, a drainage propeller, a drain port bracket, a drain port fixing bracket, a drainage propeller bracket, and a drain port drive shaft. The drain port of the drainage device is fixed to the drain port bracket and is connected to the drain port drive shaft via the drain port bracket, and is capable of rotating around the drive shaft. The drainage propeller is driven by a high-speed DC motor, and both the drainage propeller and the high-speed DC motor are fixed to the drainage propeller bracket and further connected to the drain port drive shaft, and rotate around the drive shaft synchronously with the drain port. The drain port fixing bracket, the drain port bracket, and the drainage propeller bracket are all connected to the drain port drive shaft and can rotate around the drain port drive shaft. The drain port fixing bracket is fixed to the top of the sealed drive control enclosure. The water flow channel includes space defined by an outer wall of the sealed drive control enclosure and the inner wall of the robot housing. The water filtration screen is fixed to the water flow channel,

and divides, together with the inner wall of the robot housing and the sealed drive control enclosure, the water flow channel into two portions. The water inlet and a backflow prevention device, located on a bottom surface of the robot bottom shell, include a water inlet and a backflow prevention device. The backflow prevention device is divided into two portions, which are fixed via a shaft bracket, located above the water inlet, and capable of rotating around a shaft. The drainage mechanism may be provided with one or a plurality of drainage devices. When the plurality of drainage devices are provided, drainage drive shafts of the drainage devices need to keep coaxial.

The cleaning and moving platform of the present invention includes a robot housing, cleaning drive wheels, synchronous belt gears, and synchronous drive belts. The robot housing includes a robot top cover, a robot side wall, and a robot main shell. The robot housing is made of a one-piece molded polymer material. The cleaning drive wheels include four independently driven cylindrical wheel hubs. Outer layers of the wheel hubs are configured with wheel surfaces of different materials according to cleaning requirements. The four cleaning drive wheels are arranged in pairs, and are assembled with and connected to the robot via the robot side wall, and a cleaning drive wheel lateral bracket and a cleaning drive wheel central bracket of the robot main shell. For the synchronous belt gears and the synchronous drive belts, two synchronous belt gears and one synchronous drive belt constitute one group, and are mounted between a side panel of the robot main shell and the robot side wall. One synchronous belt gear is connected to one drive DC motor, and the other synchronous belt gear is connected to one cleaning drive wheel. The two synchronous belt gears are connected via power transmission by the synchronous drive belt.

The control system of the present invention includes a central processing unit, a monitoring camera, an image acquisition card, an inertial navigation component, a remote control signal interface, a power management module, motor drivers, a control system enclosure, a cleaning drive wheel DC motor, a drain port drive servo motor, a drainage propeller high-speed DC motor, the sealed drive control enclosure, and a control and power management system. A chip of the central processing unit, the image acquisition card, the inertial navigation component, and the remote control signal interface constitute an input portion of the control system. The chip of the central processing unit and a motor driver constitute an output portion of the control system. A motor driver and the cleaning drive wheel DC motor constitute a cleaning drive execution layer of the control system. A motor driver and the drain port drive servo motor constitute a rotation execution layer of the drain port. A motor driver and the drainage propeller high-speed DC motor constitute a drive execution layer of the propeller. The monitoring camera is installed on two front panels of the robot main shell, and the monitoring camera and the image acquisition card constitute an environment perception layer of the control system. The inertial navigation component is installed on the sealed drive control enclosure of the robot to constitute an attitude positioning layer of the control system. The control system enclosure houses the control system including the central processing unit, the image acquisition card, the inertial navigation component, the remote control signal interface, the power management module, and the motor drivers, and is provided with both a power input interface and a rechargeable battery box, allowing the robot to be powered either externally or by the battery box for a short period of time. The control system enclosure is fixed to the bottom of the sealed drive control enclosure. The power management module is configured to stabilize voltage and current and monitor overcurrent and overload of a robot circuit, protecting the control system of the robot. The cleaning drive wheel DC motor is equipped with a reduction gearbox and an encoder, and is fixed to a side wall of the sealed drive control enclosure and a side wall of the robot main shell via front flanges,

to drive the cleaning drive wheels via the synchronous belt gear and the synchronous belt. The drain port drive servo motor is fixed to the drain port fixing bracket, to drive the drain port bracket and the drainage propeller bracket to rotate around the drain port drive shaft. The drainage propeller high-speed DC motor is fixed to the drainage propeller bracket, to drive the drainage propeller to rotate. Both the cleaning drive wheel DC motor and the drainage propeller high-speed DC motor are equipped with encoders, and configured to implement motor servo control with the respective motor drivers. The sealed drive control enclosure includes a sealed enclosure upper cover and a main enclosure body. The sealed enclosure upper cover includes a drain port sliding groove with a waterproof function. The sealed drive control enclosure is installed on and fixed to the interior of the robot main shell via side walls at two ends of the robot main shell, to sealingly enclose the control system components including the control system enclosure, the cleaning drive wheel DC motor, the drain port drive servo motor, and the drainage propeller high-speed DC motor. The sealed drive control enclosure is made of a one-piece molded polymer material, and has waterproof properties. The control and power management system includes a control signal buoyant antenna, a control signal buoyant antenna cable, a signal relay and cable manager, a signal and power cable, a cable guide pulley assembly, and a cable counterweight ring. The signal relay and cable manager includes a signal relay and a cable manager, and is fixed to a ground on a surface at a poolside via a manager bracket. The control signal buoyant antenna is installed on and connected to an antenna interface of the signal relay and cable manager, to receive a control signal from a control keyboard, and the control signal is relayed and transmitted to the remote control signal interface of the underwater cleaning robot via the signal and power cable. The signal relay and cable manager is equipped with an external AC power supply and an AC-to-DC converter, and is connected to a power input interface of the underwater cleaning robot via the signal and power cable to power the robot. The signal relay and cable manager controls a cable winding/unwinding motor via a motor driver, under the command of the central processing unit of the underwater cleaning robot, to execute winding and unwinding of the cable. The signal relay of the signal relay and cable manager implements a connection to the control signal buoyant antenna, and sends data to the robot. The cable manager of the signal relay and cable manager includes the cable winding/unwinding motor with an encoder, which is controlled by the central processing unit of the robot, to implement a cable winding/unwinding function. The signal and power cable includes a control signal line and a power line. Density of the cable is lower than that of water, and configured to be changed by installing the cable counterweight ring, to adjust a suspension state of the cable in water. The cable counterweight ring is made of a high-density polymer material, and is tightly interlocked with the cable, and has an adjustable installation position. The control signal buoyant antenna includes a control signal antenna and a buoyant carrier, has a density far lower than that of water, and floats on a water surface to wirelessly communicate with the control keyboard. The control signal buoyant antenna is configured to directly communicate with the remote control signal interface of the robot via the control signal buoyant antenna cable, or is installed on and fixed to the signal relay and cable manager configured to communicate with the robot via the signal and power cable. The signal relay and cable manager is capable of being connected to an external display apparatus, to display an operating condition and relevant performance indicators of the underwater cleaning robot. When the robot operates with the cable, the cable guide pulley assembly is installed at a corner of the poolside, includes a fixed pulley and a fixed pulley seat rotation shaft, and is configured to enable rotation of the fixed pulley itself and rotation of a fixed pulley assembly around the fixed pulley seat rotation shaft.

Operating modes of the underwater cleaning robot according to the present invention include manual cleaning and autonomous cleaning.

In the manual mode, a control signal is sent by manual operation using the control keyboard, to directly or indirectly control the underwater cleaning robot via the control signal buoyant antenna. In the autonomous mode, a control signal is generated by the central processing unit based on information from the environment perception layer and the attitude positioning layer, in combination with a preset cleaning task, a path and an action are autonomously planned, and the execution layer of the robot is driven, to complete an underwater cleaning task. During long-term global cleaning, the robot operates with the cable, and the signal relay and cable manager and the signal and power cable are used. During short-term local cleaning, the robot is powered by the battery box without using the signal relay and cable manager and the signal and power cable but using the control signal buoyant antenna and the control signal buoyant antenna cable, with a relatively short operating time.

The underwater cleaning robot according to the present invention completes a cleaning task through a process as follows.

The underwater cleaning robot controls an action of the robot based on a control instruction issued by the central processing unit. In the drainage mechanism, the drainage propeller high-speed DC motor drives the drainage propeller to rotate at a set rotational speed under the control of the motor driver, to drain water from the water flow channel of the robot, so that a high negative pressure is formed in the water flow channel, and pool water at the bottom of the robot is sucked into the water flow channel through the water inlet. Debris in the water is filtered by the water filtration screen, and then clean water is drained out. In addition, the motor driver of the drainage propeller high-speed DC motor is configured to determine density of the dirt in the water flow channel by monitoring the motor rotational speed and current, and issues a dirt saturation alarm when the dirt reaches a certain density. The drain port drive servo motor is controlled by the motor driver thereof, to drive the drain port bracket to rotate around the drain port drive shaft along the drain port sliding groove, to change a drainage direction. The backflow prevention device is installed on the water inlet; when water flows in through the water inlet, the backflow prevention device opens due to an acting force of the water, and when the water stops flowing in, the backflow prevention device closes due to the disappearance of the acting force of the water, thereby preventing the debris in the water flow channel from flowing out. In the cleaning and moving platform, the four independent cleaning drive wheels are controlled by their respective motor drivers, and are configured to move independently, and implement tasks of the robot including moving forward, moving backward, turning, and scrubbing for cleaning through different wheel speed combinations. When the robot is powered with the cable and executes a cleaning task, the robot performs dead reckoning by using the inertial navigation component and the cleaning drive wheel to obtain robot position information, and then the central processing unit controls the cable winding/unwinding motor to wind or unwind the signal and power cable based on an actual length requirement. A proper position is selected for installing the cable counterweight ring based on a depth of a swimming pool and an actual requirement, to adjust the suspension state of the cable in water. The signal relay and cable manager guides winding or unwinding of the cable via the cable guide pulley assembly. When the robot executes a task underwater without the cable, the control signal buoyant antenna is connected to the robot via the control signal buoyant antenna cable, to receive a remote control signal, and control the movement of the robot. During autonomous cleaning, a swimming pool cleanliness image threshold is set, the robot uses the monitoring camera to take image(s) of the bottom of the swimming pool, determines a cleanliness level of the bottom of the swimming pool by comparing the image(s) with the threshold, and plans a cleaning movement, to complete the cleaning task.

The underwater cleaning robot according to the present invention is characterized in that due to the high negative pressure in the water flow channel of the robot and the acting force of the drainage mechanism,

the robot may be attached to the vertical wall of the swimming pool for cleaning, thereby implementing a vertical wall-following movement of the robot.

The underwater cleaning robot according to the present invention is characterized in that a drain port is configured to move along the drain port sliding groove, affecting movement, cleaning, turning, and vertical wall-following movement of the robot. A plurality of drain ports coordinate to move or position along the drain port sliding groove, and the drainage directions of the drain ports are changed, to produce different acting forces on movements of the robot. When the robot is in a floating state in water, an attitude of the robot in water is adjustable by adjusting the drainage direction and drainage intensity of the two drain ports, to help the robot to have a correct attitude. Particularly, when the robot climbs on a wall, a chassis may be lifted up due to factors including a swimming pool step, so that four cleaning drive wheels of the robot fail, and in this case, a position of a drain port is adjusted to provide a propelling force for the robot to return to a normal operating condition.

The present invention has the beneficial effects of: light weight, large capacity, smart and portable movement, has the characteristics of compact and reasonable mechanical structure, and good practicability, stability, energy conservation, economical efficiency, and universality, and can help and even replace humans to autonomously complete underwater cleaning work.

Brief Description of the Drawings

FIG. 1-an overall schematic diagram of an underwater cleaning robot, in which: 1-robot housing, 2-monitoring camera, 3-cleaning drive wheel, 4-synchronous drive belt, 5-synchronous belt gear;

FIG. 2-a schematic diagram of a sealed drive control enclosure of an underwater cleaning robot, in which: 6-sealed drive control enclosure, 7-cleaning drive wheel DC motor, 8-control system enclosure, 9-drain port sliding groove;

FIG. 3-a schematic diagram of a drainage device of an underwater cleaning robot, in which: 10-drain port, 11-drainage propeller, 12-drain port bracket, 13-drain port fixing bracket, 14-drainage propeller high-speed DC motor, 15-drainage propeller bracket, 16-drain port drive servo motor, 17-drain port drive shaft;

FIG. 4-a schematic diagram of a cleaning and moving platform of an underwater cleaning robot, in which: 18-robot top cover, 19-robot main shell, 20-robot side wall, 21-cleaning drive wheel lateral bracket, 22-cleaning drive wheel central bracket;

FIG. 5-a lateral cross-sectional view of an underwater cleaning robot, in which: 23-water filtration screen, 24-water flow channel, 25-backflow prevention device, 26-water inlet;

FIG. 6-a schematic diagram of a control system of an underwater cleaning robot.

FIG. 7-a schematic diagram of an underwater cleaning robot that operates with a cable, in which: 27-control signal buoyant antenna, 28-signal relay and cable manager, 29-cable manager, 30-manager bracket, 31-control keyboard, 32-cable guide pulley assembly, 33-signal and power cable, 34-cable counterweight ring.

FIG. 8-a schematic diagram of an underwater cleaning robot that operates without a cable, in which: 35-control signal buoyant antenna cable.

Detailed Description

The present invention will be further described below with reference to the accompanying drawings and embodiments.

Embodiments

An underwater cleaning robot according to the present invention includes a drainage mechanism, a cleaning and moving platform, and a control system. As shown in FIG. 1, FIG. 2, FIG. 3, FIG. 4, FIG. 5, FIG. 6, FIG. 7, and FIG. 8, the drainage mechanism includes a drainage device, a water flow channel 24 formed by a sealed drive control enclosure and an inner wall of a robot housing, a water filtration screen 23, and a water inlet and backflow prevention device 25. The drainage device includes a drain port 10, a drainage propeller 11, a drain port bracket 12, a drain port fixing bracket 13, a drainage propeller bracket 15, and a drain port drive shaft 17. The underwater cleaning robot may be equipped with a plurality of independent drainage devices, and coordinates movement of the drainage devices. The drain port 10 of the drainage device is connected to the drain port drive shaft 17 via the drain port bracket 12 and is capable of rotating around the drive shaft. The drainage propeller 11 is driven by a high-speed DC motor, and both the drainage propeller and the high-speed DC motor are fixed to the drainage propeller bracket 15 and further connected to the drain port drive shaft 17, and rotate around the drive shaft synchronously with the drain port 10. A drain port fixing bracket 13 is fixed to the top of the sealed drive control enclosure. The water flow channel 24 includes space defined by an outer wall of the sealed drive control enclosure and the inner wall of the robot housing 1. The water filtration screen 23 is fixed to the water flow channel 24, and divides, together with the inner wall of the robot housing 1 and the sealed drive control enclosure, the water flow channel 24 into two portions. The water inlet 26 and the backflow prevention device 25 are located on a bottom surface of a robot main shell 19. The backflow prevention device is divided into two portions, which are fixed via a shaft bracket, located above the water inlet 26, and capable of rotating around a shaft. When water enters the water flow channel 24 of the robot, the two portions of the backflow prevention device 25 rotate around the shaft due to the effect of a water flow, and then the water inlet 26 is opened. When water stops entering, the backflow prevention device 25 returns to a closed state, preventing water in the water flow channel 24 from flowing back. The drainage mechanism may be provided with one or a plurality of drainage devices. When the plurality of drainage devices are provided, drain port drive shafts 17 of the drainage devices need to keep coaxial. The drainage mechanism uses the cleaning and moving platform as a carrier, and moves in coordination with the cleaning and moving platform. The cleaning and moving platform includes a robot housing 1, cleaning drive wheels 3, synchronous belt gears 5, and synchronous drive belts 4. The robot housing 1 includes a robot top cover 18, a robot side wall 20, and the robot main shell 19. The robot housing is made of a one-piece molded polymer material. The cleaning drive wheels 3 include four independently driven cylindrical wheel hubs. Outer layers of the wheel hubs are configured with wheel surfaces of different materials according to cleaning requirements. The four cleaning drive wheels 3 are arranged in pairs, and are assembled with and connected to the robot via the robot side wall, and a cleaning drive wheel lateral bracket 21 and a cleaning drive wheel central bracket 22 of the robot main shell. For the synchronous belt gears 5 and the synchronous drive belts 4, two synchronous belt gears 5 and one synchronous drive belt 4 constitute one group, and are mounted between a side panel of the robot main shell 19 and the robot side wall 20.

One synchronous belt gear 5 is connected to one drive DC motor 7, and the other synchronous belt gear 5 is connected to one cleaning drive wheel 3. The two synchronous belt gears 5 are connected via power transmission by the synchronous drive belt 4. The control system includes a central processing unit, a monitoring camera, an image acquisition card, an inertial navigation component, a remote control signal interface, motor drivers, a control system enclosure 8, a cleaning drive wheel DC motor 7, a drain port drive servo motor 16, a drainage propeller high-speed DC motor 14, the sealed drive control enclosure, and a control and power management system. A chip of the central processing unit, the image acquisition card, the inertial navigation component, and the remote control signal interface constitute an input portion of the control system. The chip of the central processing unit and a motor driver constitute an output portion of the control system. A motor driver and the cleaning drive wheel DC motor 7 constitute a cleaning drive execution layer of the control system. A motor driver and the drain port drive servo motor 16 constitute a rotation execution layer of the drain port 10. A motor driver and the drainage propeller high-speed DC motor 14 constitute a drive execution layer of the propeller 11. The monitoring camera 2 is installed on two front panels of the robot main shell 19. The monitoring camera 2 and the image acquisition card constitute an environment perception layer of the control system. The inertial navigation component is installed on the robot control system enclosure 8 to form an attitude positioning layer of the control system. The control system enclosure 8 houses the control system including the central processing unit, the image acquisition card, the inertial navigation component, the remote control signal interface, the power management module, and the motor drivers, and is provided with both a power input interface and a rechargeable battery box, allowing the robot to be powered either externally or by the battery box for a short period of time. The control system enclosure is fixed to the bottom of the sealed drive control enclosure. The power management module is configured to stabilize voltage and current and monitor overcurrent and overload of a robot circuit, protecting the control system of the robot. The cleaning drive wheel DC motor 7 is equipped with a reduction gearbox and an encoder, and is fixed to a side wall of the sealed drive control enclosure and a side wall of the robot main shell 19 via front flanges, to drive the cleaning drive wheels 3. The drain port drive servo motor 16 is installed on and fixed to the drain port fixing support 12, to drive the drain port 10 and the drain port bracket 12 to rotate around the drain port drive shaft 17. The drainage propeller high-speed DC motor 14 is fixed to the drainage propeller bracket 15, to drive the drainage propeller 11 to rotate. Both the cleaning drive wheel DC motor 7 and the drainage propeller high-speed DC motor 14 are equipped with encoders and configured to implement motor servo control with the respective motor drivers. The sealed drive control enclosure includes a sealed enclosure upper cover and a main enclosure body. The sealed enclosure body upper cover includes a drain port sliding groove 9 with a waterproof function. The sealed drive control enclosure is installed on and fixed to the interior of the robot main shell 19 via side walls at two ends of the robot main shell 19, to sealingly enclose the control system components including the control system enclosure 8, the cleaning drive wheel DC motor 7, the drain port drive servo motor 16, and the drainage propeller high-speed DC motor 14. The sealed drive control enclosure is made of a one-piece molded polymer material, and has waterproof properties. The control and power management system includes a control signal buoyant antenna 27, a control signal buoyant antenna cable 35, a signal relay and cable manager 28, a signal and power cable 33, a cable guide pulley assembly 32, and a cable counterweight ring 34. The signal relay and cable manager 28 includes a signal relay and a cable manager 29, and is fixed to a surface at a poolside via a manager bracket 30. The control signal buoyant antenna 27 is installed on and connected to an antenna interface of the signal relay and cable manager 28,

to receive a control signal from a control keyboard 31, and the control signal is relayed and transmitted to the remote control signal interface of the underwater cleaning robot via the signal and power cable 33. The signal relay and cable manager 28 is equipped with an external AC power supply and an AC-to-DC converter, and is connected to a power input interface of the underwater cleaning robot via the signal and power cable 33 to power the robot. The signal relay and cable manager 28 controls a cable winding/unwinding motor via a motor driver, under the command of the central processing unit of the underwater cleaning robot, to execute winding and unwinding of the cable. The signal relay of the signal relay and cable manager 28 implements a connection to the control signal buoyant antenna, and sends data to the robot. The cable manager 29 of the signal relay and cable manager 28 includes the cable winding/unwinding motor with an encoder, which is controlled by the central processing unit of the robot, to implement a cable winding/unwinding function. The signal and power cable 33 includes a control signal line and a power line. Density of the cable is smaller than that of water, and configured to be changed by installing the cable counterweight ring 34, to adjust a suspension state of the cable in water. The cable counterweight ring 34 is made of a high-density polymer material, and is tightly interlocked with the cable, and has an adjustable installation position. The control signal buoyant antenna 27 includes a control signal antenna and a buoyant carrier, has a density far smaller than that of water, and floats on a water surface to wirelessly communicate with the control keyboard 31. The control signal buoyant antenna is configured to directly communicate with the remote control signal interface of the robot via the control signal buoyant antenna cable 35, or is installed on and fixed to the signal relay and cable manager 28 configured to indirectly communicate with the robot via the signal and power cable 33. The signal relay and cable manager 28 is capable of being connected to an external display apparatus, to display an operating condition and relevant performance indicators of the underwater cleaning robot. When the robot operates with the cable, the cable guide pulley assembly 32 is installed at a corner of the poolside, includes a fixed pulley and a fixed pulley seat rotation shaft, and is configured to enable rotation of the fixed pulley itself and rotation of a fixed pulley assembly around the fixed pulley seat rotation shaft.

Operating modes of the underwater cleaning robot according to the present invention include manual cleaning and autonomous cleaning. In the manual mode, a control signal is sent by manual operation using the control keyboard, to directly or indirectly control the underwater cleaning robot via the control signal buoyant antenna. In the autonomous mode, a control signal is generated by the central processing unit based on information from the environment perception layer and the attitude positioning layer, in combination with a preset cleaning task, a path and an action are autonomously planned, and the execution layer of the robot is driven, to complete an underwater cleaning task. During long-term global cleaning, the robot operates with the cable, and the signal relay and cable manager 28 and the signal and power cable 33 are used. During short-term local cleaning, the robot is powered by the battery box without using the signal relay and cable manager 28 and the signal and power cable 33 but using the control signal buoyant antenna 27 and the control signal buoyant antenna cable 35, with a relatively short operating time.

The underwater cleaning robot according to the present invention completes a cleaning task through a process as follows. The underwater cleaning robot controls an action of the robot based on a control instruction issued by the central processing unit. In the drainage mechanism, the drainage propeller high-speed DC motor 14 drives the drainage propeller 11 to rotate at a set rotational speed under the control of the motor driver, to drain water from the water flow channel 24 of the robot, so that a high negative pressure is formed in the water flow channel, and pool water at the bottom of the robot is sucked into the water flow channel 24 through the water inlet.

Debris in the water is filtered by the water filtration screen 23, and then clean water is drained out. In addition, the motor driver of the drainage propeller high-speed DC motor is configured to determine density of the dirt in the water flow channel 24 by monitoring the motor rotational speed and a current, and issues a dirt saturation alarm when the dirt reaches a certain density. The drain port drive servo motor 16 is controlled by the motor driver thereof, to drive the drain port bracket 12 to rotate around the drain port drive shaft 17 along the drain port sliding groove 9, to change a drainage direction. The backflow prevention device 25 is installed on the water inlet 26; when water flows in through the water inlet, the backflow prevention device 25 opens due to an acting force of the water. When the water stops flowing in, the backflow prevention device 25 closes due to the disappearance of the acting force of the water, thereby preventing the debris in the water flow channel 24 from flowing out. In the cleaning and moving platform, the four independent cleaning drive wheels 3 are controlled by their respective motor drivers, and are configured to move independently, and implement tasks of the robot including moving forward, moving backward, turning, and scrubbing for cleaning through different wheel speed combinations. When the robot is powered with the cable and executes a cleaning task, the robot performs dead reckoning by using the inertial navigation component and the cleaning drive wheels 3 to obtain robot position information, and then the central processing unit controls the cable winding/unwinding motor to wind or unwind the signal and power cable 33 based on an actual length requirement. A proper position is selected for installing the cable counterweight ring 34 based on a depth of a swimming pool and an actual requirement, to adjust the suspension state of the cable in water. The signal relay and cable manager 28 guides winding or unwinding of the cable via the cable guide pulley assembly 32. When the robot executes a task underwater without the cable, the control signal buoyant antenna 27 is connected to the robot via the control signal buoyant antenna cable 35, to receive a remote control signal, and control the movement of the robot. During autonomous cleaning, a swimming pool cleanliness image threshold is set, the robot uses the monitoring camera 2 to take image(s) of the bottom of the swimming pool, determines a cleanliness level of the bottom of the swimming pool by comparing the image(s) with the threshold, and plans a cleaning movement, and then adjusts operating conditions of the four cleaning drive wheels 3 and the drainage device to complete the cleaning task. Specifically, the rotational speed of each wheel 3 is adjustable. Through different wheel speed combinations, cleaning actions with different cleaning intensities can be implemented. For example, if a front wheel rotates rapidly clockwise and a rear wheel rotates slowly counterclockwise, then the underwater cleaning robot may move in a direction determined by the clockwise rotation of the front wheel, and in this case, the cleaning intensity is much greater than when the rear wheel rotates clockwise. In addition, by adjusting a drainage direction of the drain port 10 and a rotational speed of the drainage propeller 11, the cleaning intensity may also be changed to improve operating efficiency of the robot. A same control strategy may be used for cleaning a vertical pool wall. The underwater cleaning robot of the present invention, due to the high negative pressure in the water flow channel 24 of the robot and the acting force of the drainage mechanism, may be attached to the vertical wall of the swimming pool for cleaning, thereby implementing a vertical wall-following movement of the robot. According to the underwater cleaning robot of the present invention, a drain port 10 is configured to move along the drain port sliding groove 9, which may affect the movement, cleaning, turning, and vertical wall-following movement of the robot. A plurality of drain ports 10 coordinate to move or position along the drain port sliding groove 9, and the drainage directions of the drain ports 10 are changed, to produce different acting forces on movements of the robot. When the robot is in a floating state in water, an attitude of the robot in water is adjustable by adjusting the drainage direction and drainage intensity of the two drain ports 10, to help the robot to have a correct attitude.

Particularly, when the robot climbs on a wall, a chassis may be lifted up due to factors including a swimming pool step, so that four cleaning drive wheels 3 of the robot fail, and in this case, a position of a drain port is adjusted to provide a propelling force for the robot to return to a normal operating condition. The underwater cleaning robot ensures autonomous navigation operation through dead reckoning based on the inertial navigation component installed thereon and the encoders of the four cleaning drive wheels 3. After a cleaning task is completed, the water flow channel 24 of the underwater cleaning robot is configured to be cleaned by opening the robot top cover 18 and the water filtration screen 23.

The present invention is not limited to this example. Any design that utilizes the design concept of this design and makes some simple changes should fall within the scope of protection of the present invention.

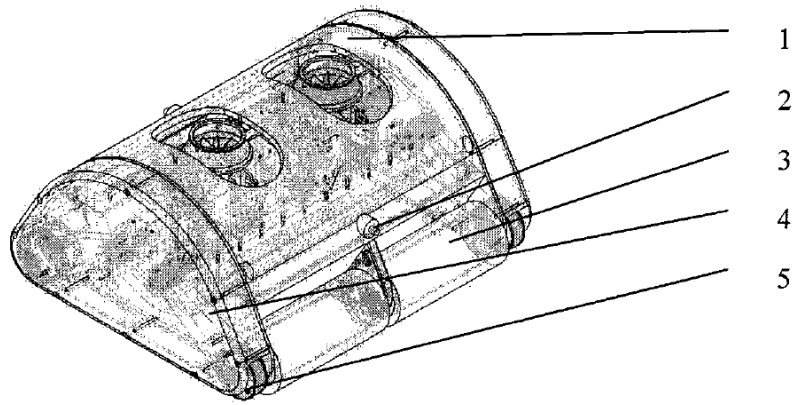

FIG. 1

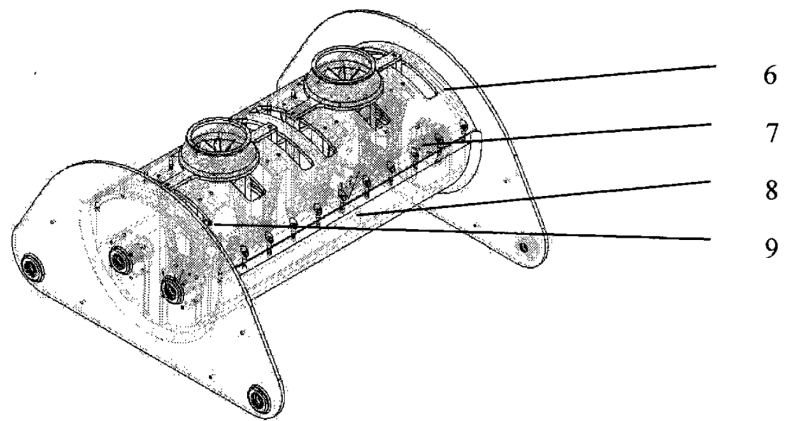

FIG. 2

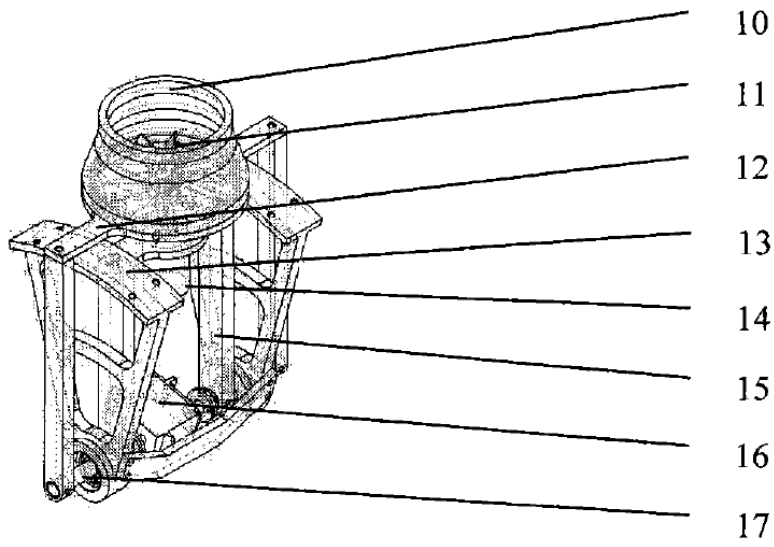

FIG. 3

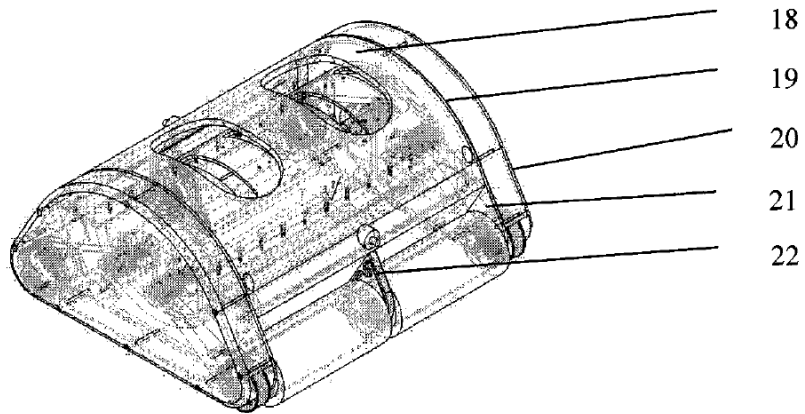

FIG. 4

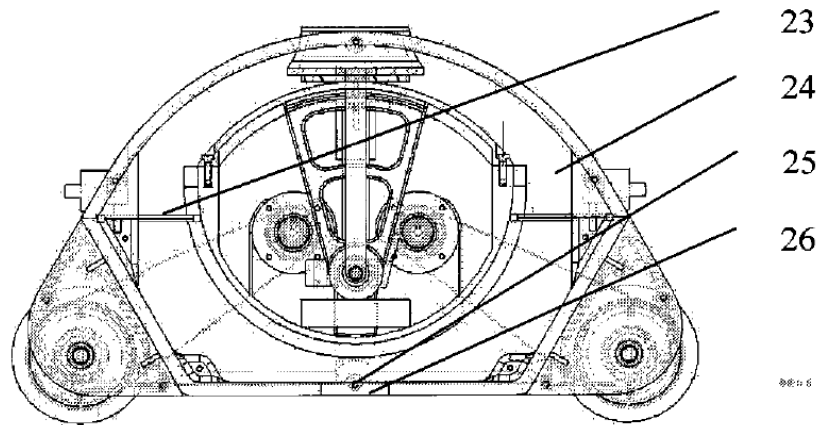

FIG. 5

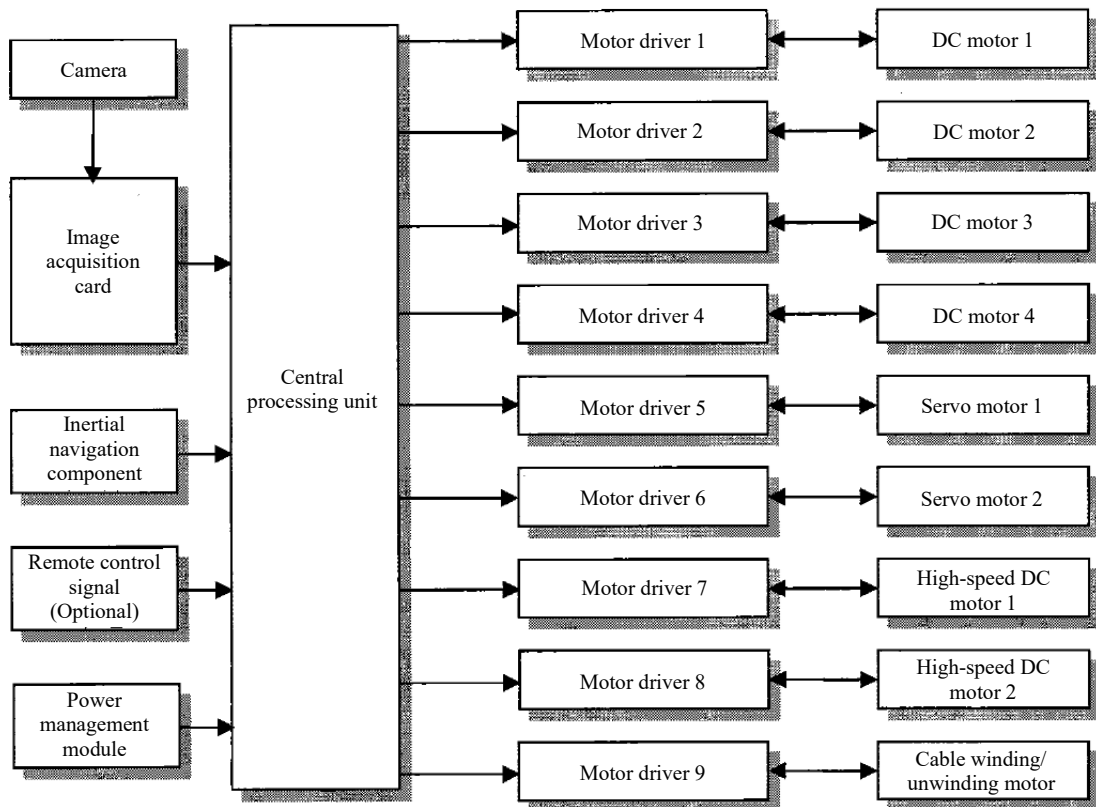

FIG. 6

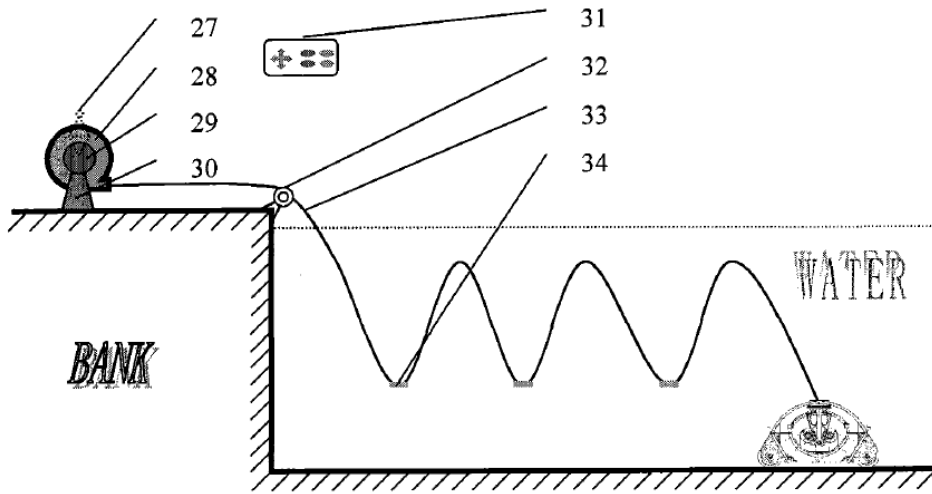

FIG. 7

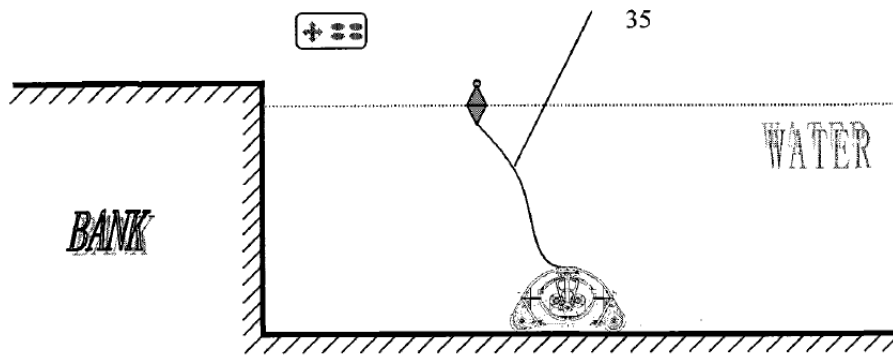

FIG. 8

[19] 中华人民共和国国家知识产权局

[51] Int. Cl.
B63C 11/42 (2006.01)



[12] 发明专利申请公布说明书

[21] 申请号 200710119800.5

[43] 公开日 2008年3月12日

[11] 公开号 CN 101139007A

[22] 申请日 2007.7.31

[21] 申请号 200710119800.5

[71] 申请人 北京理工大学

地址 100081 北京市海淀区中关村南大街5号

[72] 发明人 付梦印 王美龄 杨毅 付元
刘彤 刘伟

[74] 专利代理机构 北京理工大学专利中心
代理人 张利萍

权利要求书5页 说明书10页 附图4页

[54] 发明名称

水下清洁机器人

[57] 摘要

本发明公开了一种水下清洁机器人，所述的机器人可以在遥控和自主控制两种工作模式下进行工作，包括排水机构、清洁与移动平台以及控系统。通过排水机构、清洁与移动平台以及控制系统的配合分工，可实现机器人在水下、水平面、垂直面以及倾斜面自主或遥控地进行清洁工作。本发明具有重量轻、容量大，具有机械结构紧凑合理，实用性、稳定性、节能性、经济性和通用性好等特点，是一种可以用于游泳池池底和池壁水下清洁的机器人。

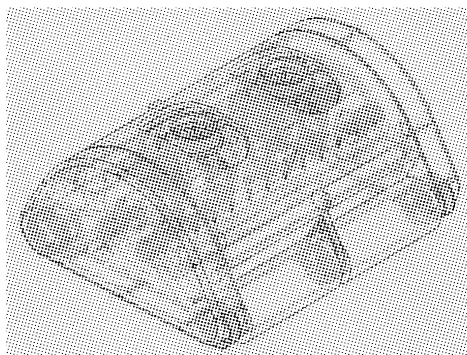

1. 一种水下清洁机器人，其特征在于：它是由排水机构、清洁与移动平台及控制系统组成；排水机构包括排水器、驱动控制密封箱与机器人外壳内壁形成的流水通道（24）、流水过滤网（23）以及进水口与防倒流装置（25）；清洁与移动平台包括机器人外壳体（1）、清洁驱动轮（3）、同步带齿轮（5）与驱动同步带（4）；控制系统包括中心处理器、监控摄像机、图像采集卡、惯性导航元件、遥控信号接口、电机驱动器、控制系统盒（8）、清洁驱动轮直流电机（7）、排水口驱动舵机（16）、排水螺旋桨高速直流电机（14）、驱动控制密封箱以及控制及能源管理系统。

2. 根据权利要求1所述的一种水下清洁机器人，其特征在于：所述的水下清洁机器人可安装多个独立的排水器，协调各排水器运动；排水口固定架（13）与驱动控制密封箱顶部固定；所述的流水通道（24）包括驱动控制密封箱外壁与机器人外壳体（1）内壁所构成空间；所述的流水过滤网（23）固定于流水通道（24），与机器人外壳体（1）内壁以及驱动控制密封箱将流水通道（24）分成两个部分；所述的进水口（26）与防倒流装置（25），位于机器人主壳体（20）底面，防倒流装置（25）分为两个部分，通过轴架固定，覆盖于进水口（26）上方，可以围绕轴转动；当水进入机器人流水通道（24）时，防倒流装置（25）的两个部分由于水流的作用，绕轴旋转，进水口（26）打开；当停止进水时，防倒流装置（25）恢复闭合状态，保证流水通道（24）内的水不会倒流。

3. 根据权利要求1所述的一种水下清洁机器人，其特征在于：排水机构以清洁与移动平台为载体，与清洁与移动平台协调运动；清洁与移动平台包括机器人外壳体（1）、清洁驱动轮（3）、同步带齿轮（5）与驱动同步带（4）；机器人外壳体（1）包括机器人上顶盖（18）、机器人侧壁（20）以及机器人主壳体（19），机器人的壳体使用一次成型的高分子材料；清洁驱动轮（3）包括四个独立驱动的圆柱形轮毂，轮毂外层可根据清洁需要配套不同材料的轮面，四个清洁驱动轮（3）两个一组，通过机器人侧壁以及机器人主壳体的清洁驱动轮侧支架（21）、清洁驱动轮中心支架（22）与机器人安装连接；同步带齿轮（5）与驱动同步带（4），两个同步带齿轮（5）与一条驱动同步带（4）为一组，安装于机器人主壳体（19）侧面板与机器人侧壁（20）之间，其中一个同步带齿轮（5）与一个驱动直流电机（7）连接，另一同步带齿轮（5）与一个清洁驱动轮（3）连接，这两个同步带齿轮（5）由驱动同步带（4）进行传动。

4. 根据权利要求1所述的一种水下清洁机器人，其特征在于：所述的控制系统包括中心处理器、监控摄像机、图像采集卡、惯性导航元件、遥控信号接

口、电机驱动器、控制系统盒（8）、清洁驱动轮直流电机（7）、排水口驱动舵机（16）、排水螺旋桨高速直流电机（14）、驱动控制密封箱以及控制及能源管理系统；所述的中心处理器芯片与图像采集卡、惯性导航元件以及遥控信号接口构成控制系统的输入部分；中心处理器芯片与电机驱动器构成控制系统的输出部分；所述的电机驱动器与清洁驱动轮直流电机（7）构成了控制系统的清洁驱动执行层；电机驱动器与排水口驱动舵机（16）构成排水口（10）转动执行层；电机驱动器与排水螺旋桨高速直流电机（14）构成螺旋桨（11）驱动执行层；所述的监控摄像机（2）安装于机器人主壳体（19）的两个正面板上，监控摄像机（2）与图像采集卡构成控制系统环境感知层；所述的惯性导航元件安装于机器人控制系统盒（8）构成控制系统自身姿态定位层；所述的控制系统盒（8）将包括中心处理器、图像采集卡、惯性导航元件、遥控信号接口、电源管理模块、电机驱动器的控制系统封装，兼有电源输入接口与可充电电池盒，可由机器人外部供电，也可短时间内由电池盒为机器人供电，控制系统盒固定于驱动控制密封箱的底部；所述的电源管理模块用于稳压稳流以及监控机器人电路的过流过载，保护机器人控制系统；所述的清洁驱动轮直流电机（7），装配有减速箱与编码器，通过前法兰安装固定于驱动控制密封箱侧壁与机器人主壳体（19）侧壁，驱动清洁驱动轮（3）；所述的排水口驱动舵机（16），安装固定于排水口固定支架（12），驱动排水口（10）及排水口支架（12）围绕排水口驱动轴（17）转动；所述的排水螺旋桨高速直流电机（14），安装固定于排水螺旋桨支架（15），驱动排水螺旋桨（11）转动；所述的清洁驱动轮直流电机（7）、排水螺旋桨高速直流电机（14）都配有编码器，可以与其电机驱动器实现电机伺服控制；所述的驱动控制密封箱，包括密封箱箱体上盖以及主箱体，密封箱箱体上盖包括有防水功能的排水口滑动槽（9）；驱动控制密封箱通过机器人主壳体（19）的两端侧壁安装固定于机器人主壳体（19）内部，将包括控制系统盒（8）、清洁驱动轮直流电机（7）、排水口驱动舵机（16）、排水螺旋桨高速直流电机（14）的控制系统部分密闭封装，使用一次成型的高分子材料，具有防水特性；所述的控制及能源管理系统包括控制信号浮漂天线（27）、控制信号浮漂天线电缆（35）、信号中继及电缆管理器（28）、信号及能源电缆（33）、电缆导向滑轮架（32）以及电缆配重环（34）；所述的信号中继及电缆管理器（28）包括信号中继器、电缆管理器（29），通过管理器支架（30）与池岸地面固定，将控制信号浮漂天线安装（27）连接于信号中继及电缆管理器（28）天线接口，接收控制键盘（31）的控制信号，经过信号中继，由信号及能源电缆（33）传

输给水下清洁机器人的遥控信号接口；信号中继及电缆管理器（28）配有外接交流电源以及交流到直流变压装置，通过信号及能源电缆（33）与水下清洁机器人的电源输入接口连接，为机器人供电；信号中继及电缆管理器（28）由水下清洁机器人中心处理器通过电机驱动器控制收放电缆电机执行电缆的收放；信号中继及电缆管理器（28）的信号中继器实现与控制信号浮漂天线连接，并发送数据给机器人；信号中继及电缆管理器（28）的电缆管理器（29）内包括带编码器的电缆收放电机，由机器人中心处理器控制，实现电缆收放功能；信号及能源电缆（33）内包括控制信号线、电源线，电缆的密度小于水的密度，可通过装配电缆配重环（34）改变其密度，以调节其在水中的悬浮状态；电缆配重环（34）为高密度高分子材料，与电缆紧密相扣，安装位置可以调节；所述的控制信号浮漂天线（27）包括控制信号天线与浮漂载体，其密度远小于水，漂浮于水面，与控制键盘（31）进行无线通讯，可通过控制信号浮漂天线电缆（35）直接与机器人遥控信号接口通讯，也可以安装固定于信号中继及电缆管理器（28），再通过信号及能源电缆（33）间接与机器人通讯；信号中继及电缆管理器（28）可以外接显示设备，显示水下清洁机器人工作状态及相关性能指标；所述的电缆导向滑轮架（32）当机器人带缆工作时，安装于岸边拐角处，包括定滑轮、定滑轮座转动轴，实现定滑轮自身转动以及定滑轮装置绕定滑轮座转动轴转动。

5. 根据权利要求 1 所述的一种水下清洁机器人，其特征在于：工作模式包括手动清洁与自主清洁；所述的手动模式，其控制信号由控制键盘人工操作发出，通过控制信号浮漂天线直接或者间接地控制水下清洁机器人；所述的自主模式，其控制信号由中央处理器根据环境感知层与自身位姿定位层的信息，结合预先设定的清洁任务，自主地规划路径与动作，驱动机器人执行层，完成水下清洁任务；长时间全局清洁时，采用机器人带缆工作，使用信号中继及电缆管理器（28）与信号及能源电缆（33）；短时间局部清洁时，机器人使用电池盒供电，不使用信号中继及电缆管理器（28）与信号及能源电缆（33），使用控制信号浮漂天线（27）及控制信号浮漂天线电缆（35），工作时间相对较短。

6. 根据权利要求 1 所述的一种水下清洁机器人，其特征在于：水下清洁机器人根据中央处理器发出的控制指令控制机器人动作；排水机构中，排水螺旋桨高速直流电机（14）在其电机驱动器的控制下带动排水螺旋桨（11）按照设定转速旋转，将机器人流水通道（24）内的水排出，使流水通道内部形成高负压，将机器人底部的池水从进水口吸入流水通道（24），经过流水过滤网（23）

过滤下水流中的杂物，将清洁的水排出；同时，排水螺旋桨高速直流电机驱动器通过对电机转速及电流的监控，可以判断流水通道（24）内污物的密度，当污物达到一定密度时，发出污物已满警报；排水口驱动舵机（16）由其电机驱动器控制，带动排水口支架（12）围绕排水口驱动轴（17）沿排水口滑动槽（9）转动，改变排水方向；进水口（26）上面安装有防倒流装置（25），当水流又进水口进入时，由于水的作用力，防倒流装置（25）打开，当水流停止进入时，防倒流装置（25）由于水的作用力消失而关闭，可以防止流水通道（24）内杂物的流出；清洁与移动平台中，4个独立的清洁驱动轮（3）由其电机驱动器控制，可以实现独立的运动，通过使用不同的轮速组合实现机器人的前进、后退、转弯以及刷洗清洁的任务。

7. 根据权利要求1所述的一种水下清洁机器人，其特征在于：当机器人带缆在水下执行清洁任务时，机器人利用惯性导航元件与清洁驱动轮（3）进行航位推算，得到机器人位置信息，进而由中心处理器控制收放电缆电机根据实际长度需要而收放信号及能源电缆（33）；根据游泳池深度与实际需要，选择合适位置安装电缆配重环（34），调节电缆在水中的悬浮状态；信号中继及电缆管理器（28）由电缆导向滑轮架（32）为电缆收放导向；当机器人脱缆在水下执行任务时，控制信号浮漂天线（27）通过控制信号浮漂天线电缆（35）与机器人连接，接收遥控信号，控制机器人运动；在自主清洁的过程中，设定游泳池清洁度图像阈值，机器人利用监控摄像机（2）拍摄游泳池池底图片，通过与阈值比较来判断游泳池池底的清洁程度，进行清洁运动规划，进而调节四个清洁驱动轮3和排水器的工作状态，完成清洁任务；同时，调整排水口（10）的排水位置方向以及排水螺旋桨（11）的转速，改变清洁力度，使机器人的工作效率更高；对于竖直池壁的清洁，也可以使用相同的控制策略。

8. 根据权利要求1所述的一种水下清洁机器人，其特征在于：机器人流水通道（24）内的高负压以及排水机构的作用力，使机器人黏附在游泳池竖直壁面上进行清洗，实现机器人竖直贴壁行进动作。

9. 根据权利要求1所述的一种水下清洁机器人，其特征在于：排水口（10）可以沿排水口滑动槽（9）运动，对机器人的行进、清洁、转向以及竖直贴壁行进产生作用；多个排水口（10）协调沿排水口滑动槽（9）运动或定位，改变排水口（10）排水方向，对机器人的运动产生不同的作用力；机器人在水中处于漂浮状态时，通过调整两个排水口（10）的排水方向与排水力度，可调节机器人在水中的姿态；当机器人在爬壁的过程中，由于游泳池台阶等因素的影响，

可能会底盘顶起，使机器人的4个清洁驱动轮（3）失效，这时调整排水口位置给机器人推动力，使其回到正常工作的状态中。

10. 根据权利要求1所述的一种水下清洁机器人，其特征在于：完成清洁任务后，打开机器人上顶盖（18）以及流水过滤网（23），对水下清洁机器人流水通道（24）可进行清洗。

水下清洁机器人

技术领域

本发明涉及一种机器人，特别用于水下环境的清洁，具有自主移动功能可以通过遥控或自主控制用于水下水平面、垂直面以及倾斜面清洁，能够代替人自主完成水下清洁工作的水下清洁机器人。

背景技术

游泳这项运动已有几千年的历史，随着现代生活节奏的加快和生活水平的提高，游泳已成为人们强身健体、休闲娱乐的重要运动形式。游泳池的清洁卫生状况直接关系到游泳者的运动状态和运动效果，因此，保持游泳池池水与池壁的清洁卫生是至关重要的。游泳池的清洁方式会根据游泳池的形式和规模而改变，就目前来看，无论是人工清洁，还是自动水循环，都在水资源或其它能源利用以及劳动力使用上存在着巨大的浪费或者冗余，造成游泳池维护成本提高，而且还直接增加了游泳者的游泳运动费用，因此，需要一种自动水下清洁装置来解决这一问题。

发明内容

本发明的目的在于提出了一种能够灵活机动、经济节能、多种工作模式的水下机器人，从而更好地完成水下清洁工作。

本发明是一种水下清洁机器人，包括排水机构、清洁与移动平台以及控制系统。

本发明所述的排水机构包括排水器、驱动控制密封箱与机器人外壳内壁形成的流水通道、流水过滤网以及进水口与防倒流装置。排水器包括排水口、排水螺旋桨、排水口支架、排水口固定架、排水螺旋桨支架以及排水口驱动轴。排水器的排水口安装固定于排水口支架，并通过排水口支架与排水口驱动轴连接，可以围绕驱动轴转动；排水螺旋桨由高速直流电机驱动，一同固定于排水螺旋桨支架，亦与排水口驱动轴连接，与排水口同步围绕驱动轴转动；排水口固定架与排水口支架以及排水螺旋桨支架共同由排水口驱动轴连接，可绕其旋转，排水口固定架与驱动控制密封箱顶部固定。所述的流水通道包括驱动控制密封箱外壁与机器人外壳内壁所构成空间。所述的流水过滤网固定于流水通道，与

机器人外壳内壁以及驱动控制密封箱将流水通道分成两个部分。所述的进水口与防倒流装置，位于机器人底壳体底面，包括进水口以及防倒流装置，防倒流装置分为两个部分，通过轴架固定，覆盖于进水口上方，可以围绕轴转动。排水机构可选择安装一个或多个排水器，当选择安装多个排水器时，要保持排水器排水器的排水驱动轴同轴。

本发明所述的清洁与移动平台包括机器人外壳体、清洁驱动轮、同步带齿轮与驱动同步带。机器人外壳体包括机器人上顶盖、机器人侧壁以及机器人主壳体，机器人的壳体使用一次成型的高分子材料。清洁驱动轮包括四个独立驱动的圆柱形轮毂，轮毂外层可根据清洁需要配套不同材料的轮面，四个清洁驱动轮两个一组，通过机器人侧壁以及机器人主壳体的清洁驱动轮侧支架、中心支架与机器人安装连接。同步带齿轮与驱动同步带，两个同步带齿轮与一条驱动同步带为一组，安装于机器人主壳体侧面板与机器人侧壁之间，其中一个同步带齿轮与一个驱动直流电机连接，另一同步带齿轮与一个清洁驱动轮连接，这两个同步带齿轮由驱动同步带进行传动。

本发明所述的控制系统包括中心处理器、监控摄像机、图像采集卡、惯性导航元件、遥控信号接口、电源管理模块、电机驱动器、控制系统盒、清洁驱动轮直流电机、排水口驱动舵机、排水螺旋桨高速直流电机、驱动控制密封箱以及控制及能源管理系统。其特征在于所述的中心处理器芯片与图像采集卡、惯性导航元件以及遥控信号接口构成控制系统的输入部分；中心处理器芯片与电机驱动器构成控制系统的输出部分。所述的电机驱动器与清洁驱动轮直流电机构成了控制系统的清洁驱动执行层；电机驱动器与排水口驱动舵机构成排水口转动执行层；电机驱动器与排水螺旋桨高速直流电机构成螺旋桨驱动执行层。所述的监控摄像机安装于机器人主壳体的两个正面板上，监控摄像机与图像采集卡构成控制系统环境感知层。所述的惯性导航元件安装于机器人驱动控制密封箱，构成控制系统自身姿态定位层。所述的控制系统盒将包括中心处理器、图像采集卡、惯性导航元件、遥控信号接口、电源管理模块、电机驱动器的控制系统封装，兼有电源输入接口与可充电电池盒，可由机器人外部供电，也可短时间内由电池盒为机器人供电，控制系统盒固定于驱动控制密封箱的底部。所述的电源管理模块用于稳压稳流以及监控机器人电路的过流过载，保护机器人控制系统。所述的清洁驱动轮直流电机，装配有减速箱与编码器，通过前法兰安装固定于驱动控制密封箱侧壁与机器人主壳体侧壁，通过同步带齿轮与同

步带，驱动清洁驱动轮。所述的排水口驱动舵机，安装固定于排水口固定架，驱动排水口支架以及排水螺旋桨支架围绕排水口驱动轴转动。所述的排水螺旋桨高速直流电机，安装固定于排水螺旋桨支架，驱动排水螺旋桨转动。所述的清洁驱动轮直流电机、排水螺旋桨高速直流电机都配有编码器，可以与其电机驱动器实现电机伺服控制。所述的驱动控制密封箱，包括密封箱箱体上盖以及主箱体，密封箱箱体上盖包括有防水功能的排水口滑动槽；驱动控制密封箱通过机器人主壳体的两端侧壁安装固定于机器人主壳体内部，将包括控制系统盒、清洁驱动轮直流电机、排水口驱动舵机、排水螺旋桨高速直流电机的控制系统部分密闭封装，使用一次成型的高分子材料，具有防水特性。所述的控制及能源管理系统包括控制信号浮漂天线、控制信号浮漂天线电缆、信号中继及电缆管理器、信号及能源电缆、电缆导向滑轮架以及电缆配重环。其特征在于所述的信号中继及电缆管理器包括信号中继器、电缆管理器，通过管理器支架与池岸地面固定，将控制信号浮漂天线安装连接于信号中继及电缆管理器天线接口，接收控制键盘的控制信号，经过信号中继，由信号及能源电缆传输给水下清洁机器人的遥控信号接口；信号中继及电缆管理器配有外接交流电源以及交流到直流变压装置，通过信号及能源电缆与水下清洁机器人的电源输入接口连接，为机器人供电；信号中继及电缆管理器由水下清洁机器人中心处理器通过电机驱动器控制收放电缆电机执行电缆的收放；信号中继及电缆管理器的信号中继器实现与控制信号浮漂天线连接，并发送数据给机器人；信号中继及电缆管理器的电缆管理器内包括带编码器的电缆收放电机，由机器人中心处理器控制，实现电缆收放功能。信号及能源电缆内包括控制信号线、电源线，电缆的密度小于水的密度，可通过装配电缆配重环改变其密度，以调节其在水中的悬浮状态。电缆配重环为高密度高分子材料，与电缆紧密相扣，安装位置可以调节。所述的控制信号浮漂天线包括控制信号天线与浮漂载体，其密度远小于水，漂浮于水面，与控制键盘进行无线通讯，可通过控制信号浮漂天线电缆直接与机器人遥控信号接口通讯，也可以安装固定于信号中继及电缆管理器，再通过信号及能源电缆间接与机器人通讯。信号中继及电缆管理器可以外接显示设备，显示水下清洁机器人工作状态及相关性能指标。所述的电缆导向滑轮架当机器人带缆工作时，安装于岸边拐角处，包括定滑轮、定滑轮座转动轴，实现定滑轮自身转动以及定滑轮装置绕定滑轮座转动轴转动。

本发明提出的水下清洁机器人其工作模式包括手动清洁与自主清洁。所述

的手动模式，其控制信号由控制键盘人工操作发出，通过控制信号浮漂天线直接或者间接地控制水下清洁机器人。所述的自主模式，其控制信号由中央处理器根据环境感知层与自身位姿定位层的信息，结合预先设定的清洁任务，自主地规划路径与动作，驱动机器人执行层，完成水下清洁任务。长时间全局清洁时，采用机器人带缆工作，使用信号中继及电缆管理器与信号及能源电缆；短时间局部清洁时，机器人使用电池盒供电，不使用信号中继及电缆管理器与信号及能源电缆，使用控制信号浮漂天线及控制信号浮漂天线电缆，工作时间相对较短。

本发明提出的水下清洁机器人完成清洁任务的过程为：

水下清洁机器人根据中央处理器发出的控制指令控制机器人动作。排水机构中，排水螺旋桨高速直流电机在其电机驱动器的控制下带动排水螺旋桨按照设定转速旋转，将机器人流水通道内的水排出，使流水通道内部形成高压，将机器人底部的池水从进水口吸入流水通道，经过流水过滤网过滤下水流中的杂物，将清洁的水排出。同时，排水螺旋桨高速直流电机驱动器通过对电机转速及电流的监控，可以判断流水通道内污物的密度，当污物达到一定密度时，发出污物已满警报。排水口驱动舵机由其电机驱动器控制，带动排水口支架围绕排水口驱动轴沿排水口滑动槽转动，改变排水方向。进水口上面安装有防倒流装置，当水流从进水口进入时，由于水的作用力，防倒流装置打开，当水流停止进入时，防倒流装置由于水的作用力消失而关闭，可以防止流水通道内杂物的流出。清洁与移动平台中，4个独立的清洁驱动轮由其电机驱动器控制，可以实现独立的运动，通过使用不同的轮速组合实现机器人的前进、后退、转弯以及刷洗清洁的任务。当机器人带缆在水下执行清洁任务时，机器人利用惯性导航元件与清洁驱动轮进行航位推算，得到机器人位置信息，进而由中心处理器控制收放电缆电机根据实际长度需要而收放信号及能源电缆。根据游泳池深度与实际需要，选择合适位置安装电缆配重环，调节电缆在水中的悬浮状态。信号中继及电缆管理器由电缆导向滑轮架为电缆收放导向。当机器人脱缆在水下执行任务时，控制信号浮漂天线通过控制信号浮漂天线电缆与机器人连接，接收遥控信号，控制机器人运动。在自主清洁的过程中，设定游泳池清洁度图像阈值，机器人利用监控摄像机拍摄游泳池池底图片，通过与阈值比较来判断游泳池池底的清洁程度，进行清洁运动规划，完成清洁任务。

本发明提出的水下清洁机器人其特征在于由于机器人流水通道内的高负压以

及排水机构的作用力，可使机器人黏附在游泳池竖直壁面上进行清洗，实现机器人竖直贴壁行进动作。

本发明提出的水下清洁机器人其特征在于由于排水口可以沿排水口滑动槽运动，可以对机器人的行进、清洁、转向以及竖直贴壁行进产生作用。多个排水口协调沿排水口滑动槽运动或定位，改变排水口排水方向，对机器人的运动产生不同的作用力。如机器人在水中处于漂浮状态时，可以通过调整两个排水口的排水方向与排水力度，调节机器人在水中的姿态，帮助机器人正确的姿态。特别是当机器人在爬壁的过程中，由于游泳池台阶等因素的影响，可能会底盘顶起，使机器人的4个清洁驱动轮失效，这时要靠调整排水口位置给机器人推动力，使其回到正常工作的状态中来。

本发明的有益效果是：重量小、容量大，运动灵巧轻便，具有机械结构紧凑合理，智能性、实用性、稳定性、节能性、经济性和通用性好等特点，能够帮助以及代替人工自主完成水下清洁工作。

附图说明

图1—水下清洁机器人整体示意图，其中：1—机器人外壳体，2—监控摄像机，3—清洁驱动轮，4—驱动同步带，5—同步带齿轮；

图2—水下清洁机器人驱动控制密封箱示意图，其中：6—驱动控制密封箱，7—清洁驱动轮直流电机，8—控制系统盒，9—排水口滑动槽；

图3—水下清洁机器人排水器示意图，其中：10—排水口，11—排水螺旋桨，12—排水口支架，13—排水口固定架，14—排水螺旋桨高速直流电机，15—排水螺旋桨支架，16—排水口驱动舵机，17—排水口驱动轴；

图4—水下清洁机器人清洁与移动平台示意图，其中：18—机器人上顶盖，19—机器人主壳体，20—机器人侧壁，21—清洁驱动轮侧支架，22—清洁驱动轮中心支架；

图5—水下清洁机器人侧向剖面图，其中：23—流水过滤网，24—流水通道，25—防倒流装置，26—进水口；

图6—水下清洁机器人控制系统示意图。

图7—水下清洁机器人带缆工作示意图，其中：27—控制信号浮漂天线，28—信号中继及电缆管理器，29—电缆管理器，30—管理器支架，31—控制键盘，32—电缆导向滑轮架，33—信号及能源电缆，34—电缆配重环。

图8—水下清洁机器人脱缆工作示意图，其中：35—控制信号浮漂天线电缆。

具体实施方式

下面结合附图和实施例对本发明作进一步说明。

实施例

本发明的水下清洁机器人包括排水机构、清洁与移动平台以及控制系统。如图1、图2、图3、图4、图5、图6、图7以及图8所示，所述的排水机构包括排水器、驱动控制密封箱与机器人外壳内壁形成的流水通道24、流水过滤网23以及进水口与防倒流装置25。排水器包括排水口10、排水螺旋桨11、排水口支架12、排水口固定架13、排水螺旋桨支架15以及排水口驱动轴17。水下清洁机器人可安装多个独立的排水器，协调各排水器的运动。排水器排水口10通过排水口支架12与排水口驱动轴17连接，可以围绕驱动轴转动；排水螺旋桨11由高速直流电机驱动，一同固定于排水螺旋桨支架15，亦与排水口驱动轴17连接，与排水口10同步围绕驱动轴转动；排水口固定架13与驱动控制密封箱顶部固定。流水通道24包括驱动控制密封箱外壁与机器人外壳体1内壁所构成空间。流水过滤网23固定于流水通道24，与机器人外壳体1内壁以及驱动控制密封箱将流水通道24分成两个部分。进水口26与防倒流装置25，位于机器人主壳体19底面，防倒流装置分为两个部分，通过轴架固定，覆盖于进水口26上方，可以围绕轴转动。当水进入机器人流水通道24时，防倒流装置25的两个部分由于水流的作用，绕轴旋转，进水口26打开；当停止进水时，防倒流装置25恢复闭合状态，保证流水通道24内的水不会倒流。排水机构可选择安装一个或多个排水器，当选择安装多个排水器时，要保持排水器排水器的排水口驱动轴17同轴。所述的排水机构以清洁与移动平台为载体，与清洁与移动平台协调运动。所述的清洁与移动平台包括机器人外壳体1、清洁驱动轮3、同步带齿轮5与驱动同步带4。其特征在于所述的机器人外壳体1包括机器人上顶盖18、机器人侧壁20以及机器人主壳体19，机器人的壳体使用一次成型的高分子材料。所述的清洁驱动轮3包括四个独立驱动的圆柱形轮毂，轮毂外层可根据清洁需要配套不同材料的轮面，四个清洁驱动轮3两个一组，通过机器人侧壁以及机器人主壳体的清洁驱动轮侧支架21、清洁驱动轮中心支架22与机器人安装连接。所述的同步带齿轮5与驱动同步带4，两个同步带齿轮5与一条驱动同步带4为一组，安装于机器人主壳体19侧面板与机器人侧壁20之间，其中一

个同步带齿轮 5 与一个驱动直流电机 7 连接，另一同步带齿轮 5 与一个清洁驱动轮 3 连接，这两个同步带齿轮 5 由驱动同步带 4 进行传动。控制系统包括中心处理器、监控摄像机、图像采集卡、惯性导航元件、遥控信号接口、电机驱动器、控制系统盒 8、清洁驱动轮直流电机 7、排水口驱动舵机 16、排水螺旋桨高速直流电机 14、驱动控制密封箱以及控制及能源管理系统。中心处理器芯片与图像采集卡、惯性导航元件以及遥控信号接口构成控制系统的输入部分；中心处理器芯片与电机驱动器构成控制系统的输出部分。电机驱动器与清洁驱动轮直流电机 7 构成了控制系统的清洁驱动执行层；电机驱动器与排水口驱动舵机 16 构成排水口 10 转动执行层；电机驱动器与排水螺旋桨高速直流电机 14 构成螺旋桨 11 驱动执行层。所述的监控摄像机 2 安装于机器人主壳体 19 的两个正面板上，监控摄像机 2 与图像采集卡构成控制系统环境感知层。所述的惯性导航元件安装于机器人控制系统盒 8 构成控制系统自身姿态定位层。控制系统盒 8 将包括中心处理器、图像采集卡、惯性导航元件、遥控信号接口、电源管理模块、电机驱动器的控制系统封装，兼有电源输入接口与可充电电池盒，可由机器人外部供电，也可短时间内由电池盒为机器人供电，控制系统盒固定于驱动控制密封箱的底部。所述的电源管理模块用于稳压稳流以及监控机器人电路的过流过载，保护机器人控制系统。所述的清洁驱动轮直流电机 7，装配有减速箱与编码器，通过前法兰安装固定于驱动控制密封箱侧壁与机器人主壳体 19 侧壁，驱动清洁驱动轮 3。排水口驱动舵机 16，安装固定于排水口固定支架 12，驱动排水口 10 及排水口支架 12 围绕排水口驱动轴 17 转动。排水螺旋桨高速直流电机 14，安装固定于排水螺旋桨支架 15，驱动排水螺旋桨 11 转动。清洁驱动轮直流电机 7、排水螺旋桨高速直流电机 14 都配有编码器，可以与其电机驱动器实现电机伺服控制。驱动控制密封箱，包括密封箱箱体上盖以及主箱体，密封箱箱体上盖包括有防水功能的排水口滑动槽 9；驱动控制密封箱通过机器人主壳体 19 的两端侧壁安装固定于机器人主壳体 19 内部，将包括控制系统盒 8、清洁驱动轮直流电机 7、排水口驱动舵机 16、排水螺旋桨高速直流电机 14 的控制系统部分密闭封装，使用一次成型的高分子材料，具有防水特性。控制及能源管理系统包括控制信号浮漂天线 27、控制信号浮漂天线电缆 35、信号中继及电缆管理器 28、信号及能源电缆 33、电缆导向滑轮架 32 以及电缆配重环 34。信号中继及电缆管理器 28 包括信号中继器、电缆管理器 29，通过管理器支架 30 与池岸地面固定，将控制信号浮漂天线安装 27 连接于信号中继及电缆管理器

28 天线接口，接收控制键盘 31 的控制信号，经过信号中继，由信号及能源电缆 33 传输给水下清洁机器人的遥控信号接口；信号中继及电缆管理器 28 配有外接交流电源以及交流到直流变压装置，通过信号及能源电缆 33 与水下清洁机器人的电源输入接口连接，为机器人供电；信号中继及电缆管理器 28 由水下清洁机器人中心处理器通过电机驱动器控制收放电缆电机执行电缆的收放；信号中继及电缆管理器 28 的信号中继器实现与控制信号浮漂天线连接，并发送数据给机器人；信号中继及电缆管理器 28 的电缆管理器 29 内包括带编码器的电缆收放电机，由机器人中心处理器控制，实现电缆收放功能。信号及能源电缆 33 内包括控制信号线、电源线，电缆的密度小于水的密度，可通过装配电缆配重环 34 改变其密度，以调节其在水中的悬浮状态。电缆配重环 34 为高密度高分子材料，与电缆紧密相扣，安装位置可以调节。控制信号浮漂天线 27 包括控制信号天线与浮漂载体，其密度远小于水，漂浮于水面，与控制键盘 31 进行无线通讯，可通过控制信号浮漂天线电缆 35 直接与机器人遥控信号接口通讯，也可以安装固定于信号中继及电缆管理器 28，再通过信号及能源电缆 33 间接与机器人通讯。信号中继及电缆管理器 28 可以外接显示设备，显示水下清洁机器人工作状态及相关性能指标。电缆导向滑轮架 32 当机器人带缆工作时，安装于岸边拐角处，包括定滑轮、定滑轮座转动轴，实现定滑轮自身转动以及定滑轮装置绕定滑轮座转动轴转动。

本发明提出的水下清洁机器人其工作模式包括手动清洁与自主清洁。所述的手动模式，其控制信号由控制键盘人工操作发出，通过控制信号浮漂天线直接或者间接地控制水下清洁机器人。所述的自主模式，其控制信号由中央处理器根据环境感知层与自身位姿定位层的信息，结合预先设定的清洁任务，自主地规划路径与动作，驱动机器人执行层，完成水下清洁任务。长时间全局清洁时，采用机器人带缆工作，使用信号中继及电缆管理器 28 与信号及能源电缆 33；短时间局部清洁时，机器人使用电池盒供电，不使用信号中继及电缆管理器 28 与信号及能源电缆 33，使用控制信号浮漂天线 27 及控制信号浮漂天线电缆 35，工作时间相对较短。

本发明提出的水下清洁机器人完成清洁任务的过程为：水下清洁机器人根据中央处理器发出的控制指令控制机器人动作。排水机构中，排水螺旋桨高速直流电机 14 在其电机驱动器的控制下带动排水螺旋桨 11 按照设定转速旋转，将机器人流水通道 24 内的水排出，使流水通道内部形成高负压，将机器人底部

的池水从进水口吸入流水通道 24，经过流水过滤网 23 过滤下水流中的杂物，将清洁的水排出。同时，排水螺旋桨高速直流电机驱动器通过对电机转速及电流的监控，可以判断流水通道 24 内污物的密度，当污物达到一定密度时，发出污物已满警报。排水口驱动舵机 16 由其电机驱动器控制，带动排水口支架 12 围绕排水口驱动轴 17 沿排水口滑动槽 9 转动，改变排水方向。进水口 26 上面安装有防倒流装置 25，当水流从进水口进入时，由于水的作用力，防倒流装置 25 打开，当水流停止进入时，防倒流装置 25 由于水的作用力消失而关闭，可以防止流水通道 24 内杂物的流出。清洁与移动平台中，4 个独立的清洁驱动轮 3 由其电机驱动器控制，可以实现独立的运动，通过使用不同的轮速组合实现机器人的前进、后退、转弯以及刷洗清洁的任务。当机器人带缆在水下执行清洁任务时，机器人利用惯性导航元件与清洁驱动轮 3 进行航位推算，得到机器人位置信息，进而由中心处理器控制收放电缆电机根据实际长度需要而收放信号及能源电缆 33。根据游泳池深度与实际需要，选择合适位置安装电缆配重环 34，调节电缆在水中的悬浮状态。信号中继及电缆管理器 28 由电缆导向滑轮架 32 为电缆收放导向。当机器人脱缆在水下执行任务时，控制信号浮漂天线 27 通过控制信号浮漂天线电缆 35 与机器人连接，接收遥控信号，控制机器人运动。在自主清洁的过程中，设定游泳池清洁度图像阈值，机器人利用监控摄像机 2 拍摄游泳池池底图片，通过与阈值比较来判断游泳池池底的清洁程度，进行清洁运动规划，进而调节四个清洁驱动轮 3 和排水器的工作状态，完成清洁任务。具体可以调整每个轮子 3 的转速，通过不同的轮速组合，实现不同力度的清洁动作，例如，前轮顺时针快速旋转，后轮逆时针慢速旋转，水下清洁机器人则会沿前轮顺时针旋转所确定的方向行进，但这时的清洁力度要比后轮顺时针旋转时要大很多。同时，调整排水口 10 的排水位置方向以及排水螺旋桨 11 的转速，也可以改变清洁力度，使机器人的工作效率更高。对于竖直池壁的清洁，也可以使用相同的控制策略。本发明提出的水下清洁机器人由于机器人流水通道 24 内的高负压以及排水机构的作用力，可使机器人黏附在游泳池竖直壁面上进行清洗，实现机器人竖直贴壁行进动作。本发明提出的水下清洁机器人由于排水口 10 可以沿排水口滑动槽 9 运动，可以对机器人的行进、清洁、转向以及竖直贴壁行进产生作用。多个排水口 10 协调沿排水口滑动槽 9 运动或定位，改变排水口 10 排水方向，对机器人的运动产生不同的作用力。如机器人在水中处于漂浮状态时，可以通过调整两个排水口 10 的排水方向与排水力度，调节机器人

在水中的姿态，帮助机器人正确的姿态。特别是当机器人在爬壁的过程中，由于游泳池台阶等因素的影响，可能会底盘顶起，使机器人的 4 个清洁驱动轮 3 失效，这时要靠调整排水口位置给机器人推动力，使其回到正常工作的状态中来。水下清洁机器人根据自身安装的惯性导航元件与 4 个清洁驱动轮 3 的编码器通过航位推算保证水下清洁机器人自主导航运行。当完成清洁任务后，打开机器人上顶盖 18 以及流水过滤网 23，然后对水下清洁机器人流水通道 24 进行清洗即可。

本发明不限于此实例，凡是利用本设计的设计思路，做一些简单变化的设计都应进入该发明的保护范围之内。



图 1



图 2

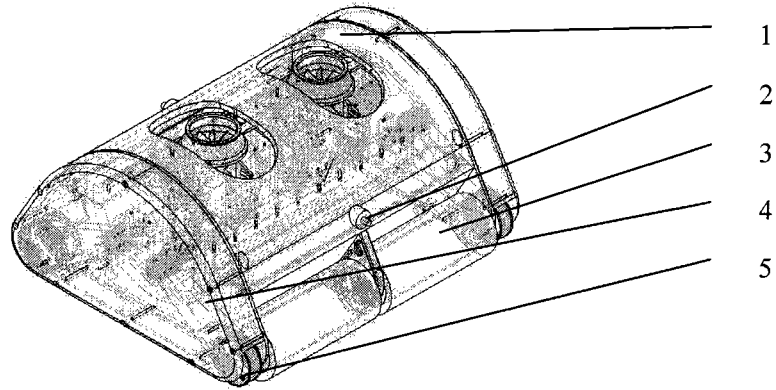

图 3

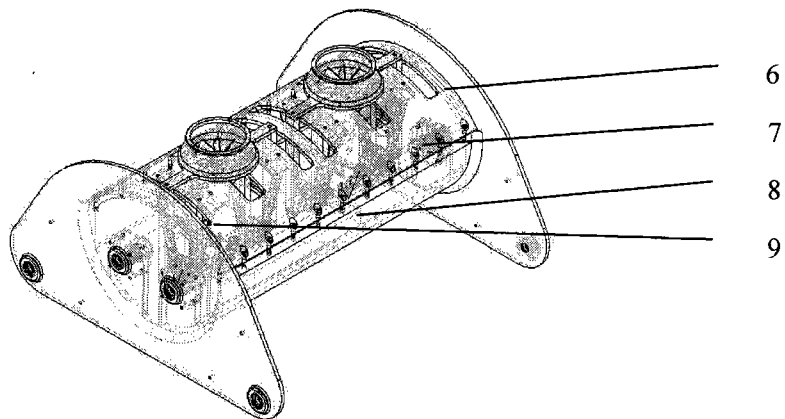

图 4

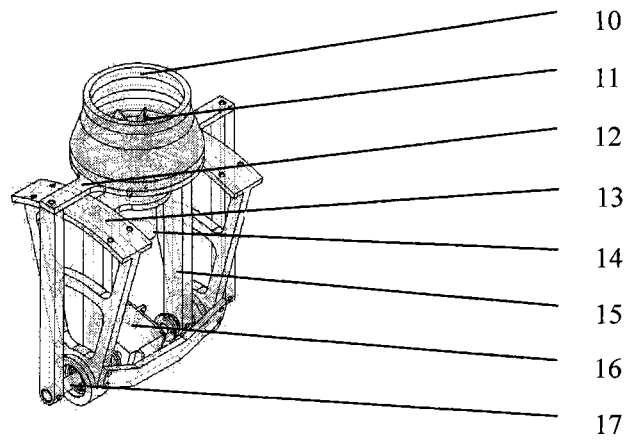

图 5

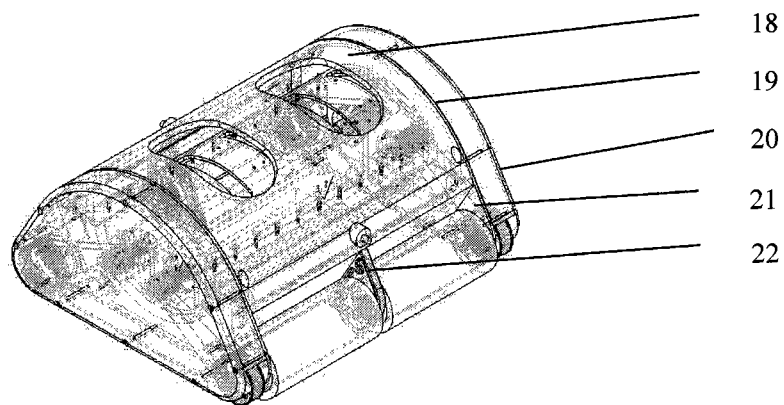

图 6

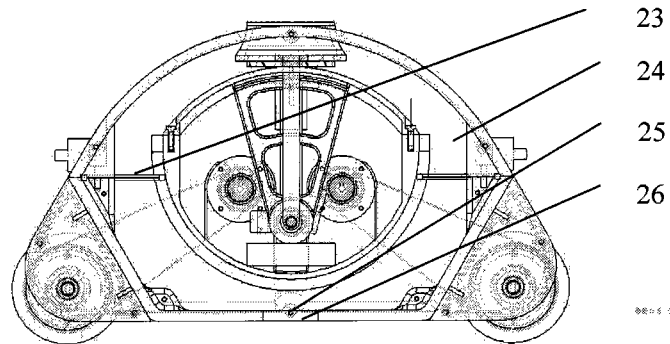

图 7

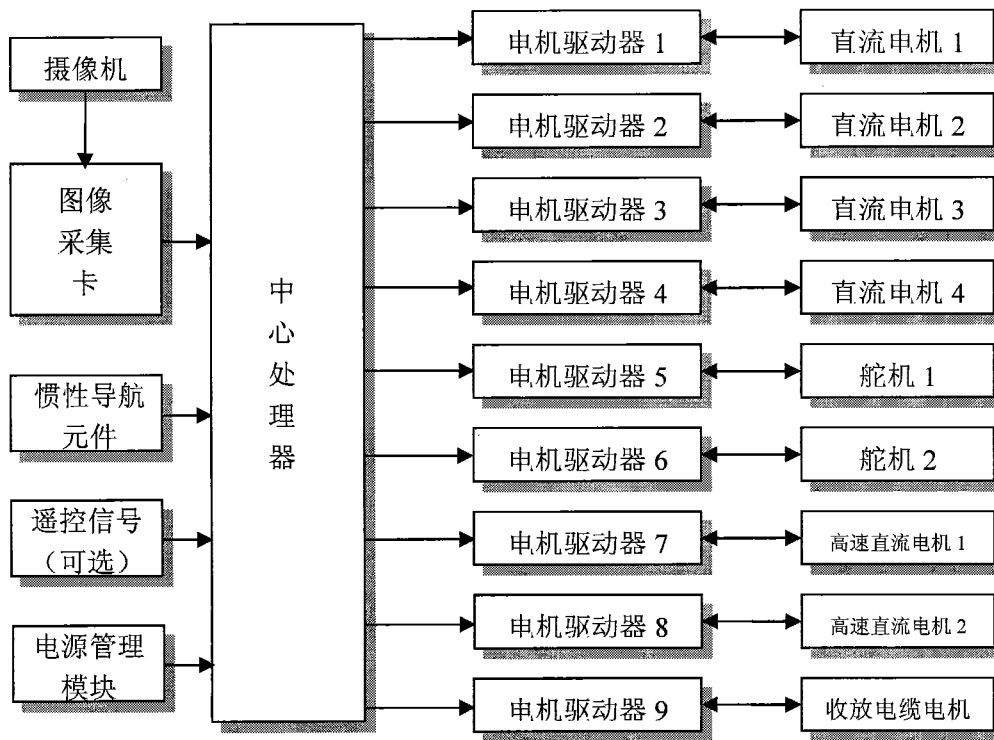
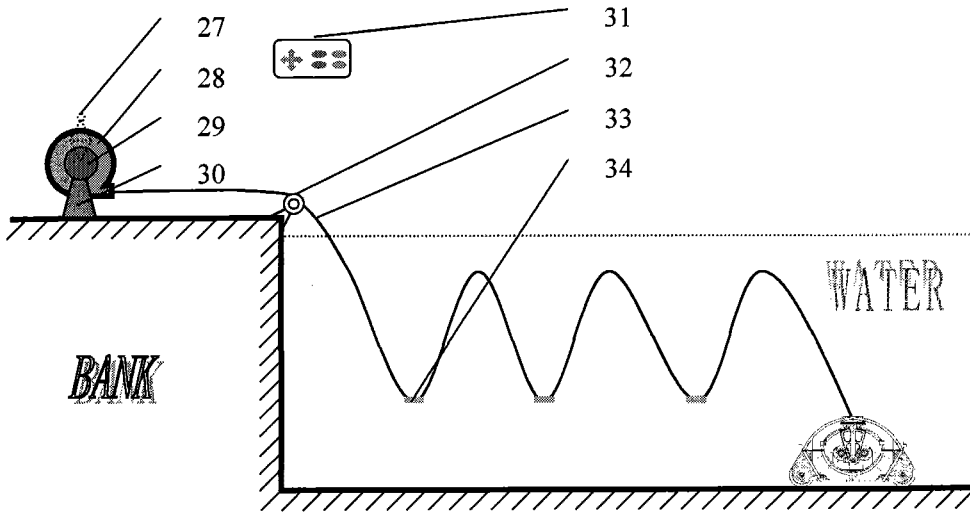
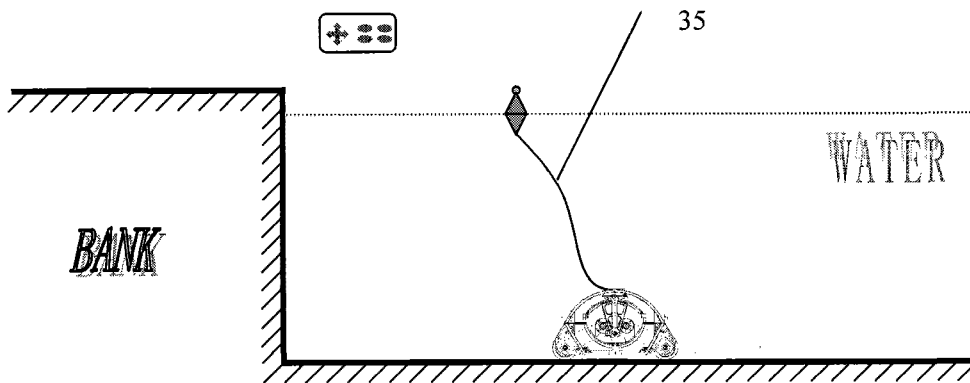

图 8