

Organization of Computer Systems: § 4: Processors

Instructor: [M.S. Schmalz](#)

[Reading Assignments and Exercises](#)

This section is organized as follows:

- 4.1. The Central Processor - Control and Dataflow
- 4.2. Datapath Design and Implementation
- 4.3. Single-Cycle and Multicycle Datapaths
- 4.4. Controller Finite State Machines
- 4.5. Microprogrammed Control

Information contained herein was compiled from a variety of text- and Web-based sources, is intended as a teaching aid only (to be used in conjunction with the [required text](#), and is not to be used for any commercial purpose. Particular thanks is given to Dr. Enrique Mafla for his permission to use selected illustrations from his course notes in these Web pages.

4.1. The Central Processor - Control and Dataflow

[Reading Assignments and Exercises](#)

Recall that, in Section 3, we designed an ALU based on (a) building blocks such as multiplexers for selecting an operation to produce ALU output, (b) carry lookahead adders to reduce the complexity and (in practice) the critical pathlength of arithmetic operations, and (c) components such as coprocessors to perform costly operations such as floating point arithmetic. We also showed that computer arithmetic suffers from errors due to finite precision, lack of associativity, and limitations of protocols such as the IEEE 754 floating point standard.

4.1.1. Review

In previous sections, we discussed computer organization at the microarchitectural level, processor organization (in terms of datapath, control, and register file), as well as logic circuits including clocking methodologies and sequential circuits such as latches.

In Figure 4.1, the typical organization of a modern von Neumann processor is illustrated. Note that the CPU, memory subsystem, and I/O subsystem are connected by address, data, and control buses. The fact that these are parallel buses is denoted by the slash through each line that signifies a bus.

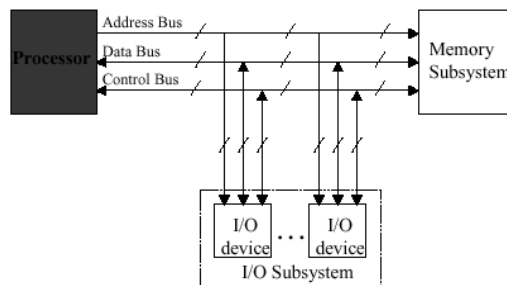

Figure 4.1. Schematic diagram of a modern von Neumann processor, where the CPU is denoted by a shaded box -adapted from [Maf01].

It is worthwhile to further discuss the following components in Figure 4.1:

- *Processor (CPU)* is the active part of the computer, which does all the work of data manipulation and decision making.
- *Datapath* is the hardware that performs all the required operations, for example, ALU, registers, and internal buses.
- *Control* is the hardware that tells the datapath what to do, in terms of switching, operation selection, data movement between ALU components, etc.

The processor represented by the shaded block in Figure 4.1 is organized as shown in Figure 4.2. Observe that the ALU performs I/O on data stored in the register file, while the Control Unit sends (receives) control signals (resp. data) in conjunction with the register file.

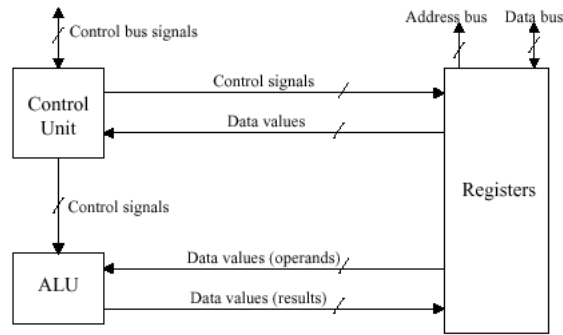

Figure 4.2. Schematic diagram of the processor in Figure 4.1, adapted from [Maf01].

In MIPS, the ISA determines many aspects of the processor implementation. For example, implementational strategies and goals affect clock rate and CPI. These implementational constraints cause parameters of the components in Figure 4.3 to be modified throughout the design process.

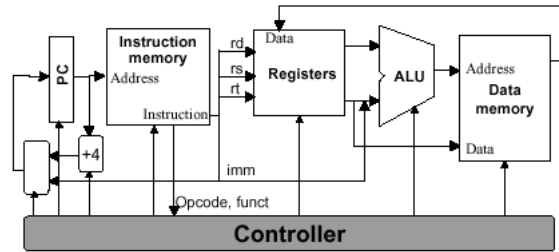
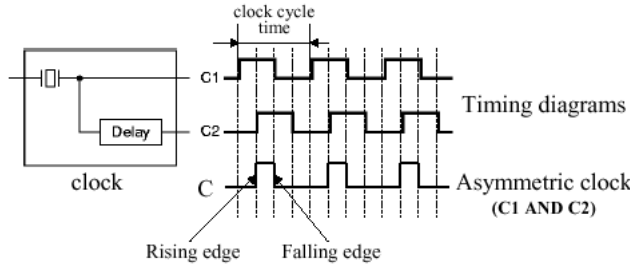

Figure 4.3. Schematic diagram of MIPS architecture from an implementational perspective, adapted from [Maf01].

Such implementational concerns are reflected in the use of logic elements and clocking strategies. For example, with combinational elements such as adders, multiplexers, or shifters, outputs depend only on current inputs. However, sequential elements such as memory and registers contain state information, and their output thus depends on their inputs (data values and clock) as well as on the stored state. The clock determines the order of events within a gate, and defines when signals can be converted to data to be read or written to processor components (e.g., registers or memory). For purposes of review, the following diagram of clocking is presented:



Here, a signal that is held at logic high value is said to be *asserted*. In Section 1, we discussed how edge-triggered clocking can support a precise state transition on the active clock pulse edge (either the rising or falling edge, depending on what the designer selects). We also reviewed the SR Latch based on *nor* logic, and showed how this could be converted to a clocked SR latch. From this, a clocked D Latch and the D flip-flop were derived. In particular, the D flip-flop has a falling-edge trigger, and its output is initially deasserted (i.e., the logic low value is present).

4.1.2. Register File

The register file (RF) is a hardware device that has two read ports and one write port (corresponding to the two inputs and one output of the ALU). The RF and the ALU together comprise the two elements required to compute MIPS R-format ALU instructions. The RF is comprised of a set of registers that can be read or written by supplying a register number to be accessed, as well (in the case of write operations) as a write authorization bit. A block diagram of the RF is shown in Figure 4.4a.

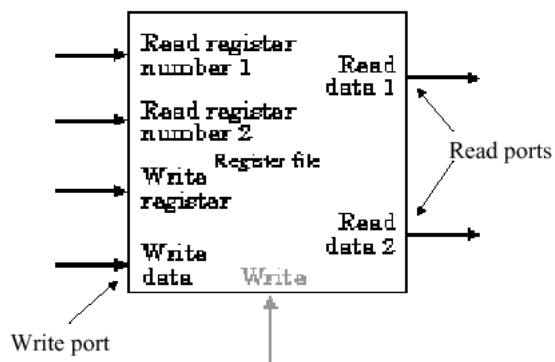

(a)

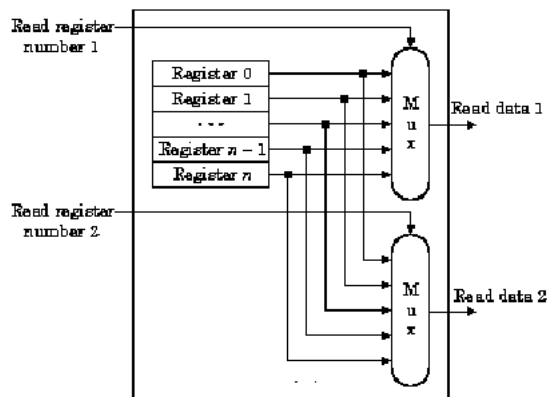

(b)

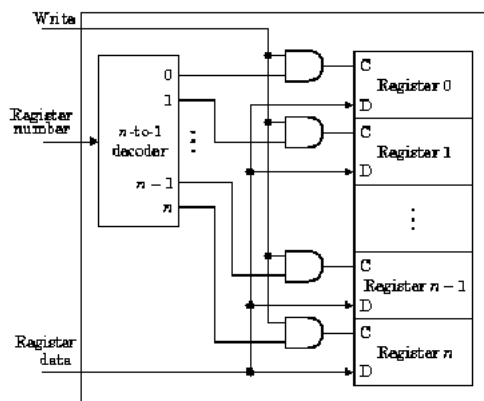

(c)

Figure 4.4. Register file (a) block diagram, (b) implementation of two read ports, and (c) implementation of write port - adapted from [Maf01].

Since reading of a register-stored value does not change the state of the register, no "safety mechanism" is needed to prevent inadvertent overwriting of stored data, and we need only supply the register number to obtain the data stored in that register. (This data is available at the Read Data output in Figure 4.4a.) However, when writing to a register, we need (1) a register number, (2) an authorization bit, for safety (because the previous contents of the register selected for writing are overwritten by the write operation), and (3) a clock pulse that controls writing of data into the register.

In this discussion and throughout this section, we will assume that the register file is structured as shown in Figure 4.4a. We further assume that each register is constructed from a linear array of D flip-flops, where each flip-flop has a clock (C) and data (D) input. The read ports can be implemented using two multiplexers, each having $\log_2 N$ control lines, where N is the number of bits in each register of the RF. In Figure 4.4b, note that data from all $N = 32$ registers flows out to the output muxes, and the data stream from the register to be read is selected using the mux's five control lines. Similar to the ALU design presented in Section 3, parallelism is exploited for speed and simplicity.

In Figure 4.4c is shown an implementation of the RF write port. Here, the *write enable* signal is a clock pulse that activates the edge-triggered D flip-flops which comprise each register (shown as a rectangle with clock (C) and data (D) inputs). The register number is input to an N -to- 2^N decoder, and acts as the control signal to switch the data stream input into the Register Data input. The actual data switching is done by *and*-ing the data stream with the decoder output: only the *and* gate that has a unitary (one-valued) decoder output will pass the data into the selected register (because $1 \text{ and } x = x$).

We next discuss how to construct a datapath from a register file and an ALU, among other components.

4.2. Datapath Design and Implementation

Reading Assignments and Exercises

The datapath is the "brawn" of a processor, since it implements the fetch-decode-execute cycle. The general discipline for datapath design is to (1) determine the instruction classes and formats in the ISA, (2) design datapath components and interconnections for each instruction class or format, and (3) compose the datapath segments designed in Step 2) to yield a composite datapath.

Simple datapath components include *memory* (stores the current instruction), *PC* or program counter (stores the address of current instruction), and *ALU* (executes current instruction). The interconnection of these simple components to form a basic datapath is illustrated in Figure 4.5. Note that the register file is written to by the output of the ALU. As in Section 4.1, the register file shown in Figure 4.6 is clocked by the RegWrite signal.

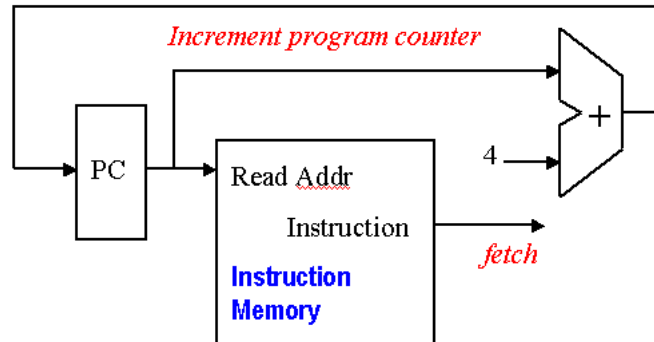

Figure 4.5. Schematic high-level diagram of MIPS datapath from an implementational perspective, adapted from [Maf01].

Implementation of the datapath for I- and J-format instructions requires two more components - a *data memory* and a *sign extender*, illustrated in Figure 4.6. The data memory stores ALU results and operands, including instructions, and has two enabling inputs (MemWrite and MemRead) that cannot both be active (have a logical high value) at the same time. The data memory accepts an address and either accepts data (WriteData port if MemWrite is enabled) or outputs data (ReadData port if MemRead is enabled), at the indicated address. The sign extender adds 16 leading digits to a 16-bit word with most significant bit *b*, to produce a 32-bit word. In particular, the additional 16 digits have the same value as *b*, thus implementing sign extension in twos complement representation.

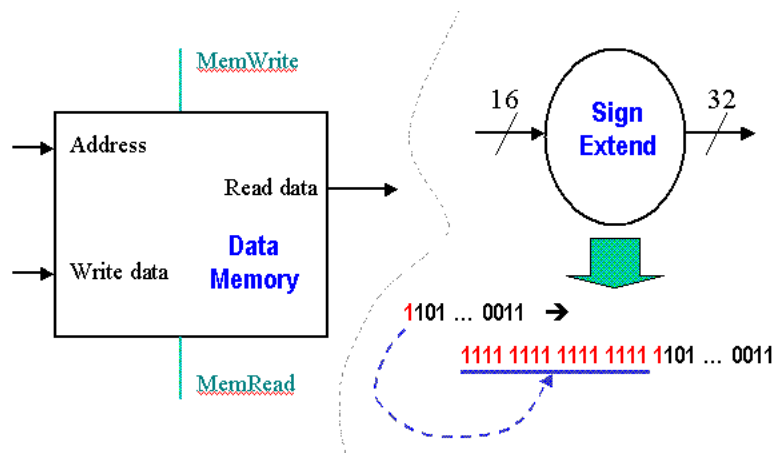

Figure 4.6. Schematic diagram of Data Memory and Sign Extender, adapted from [Maf01].

4.2.1. R-format Datapath

Implementation of the datapath for R-format instructions is fairly straightforward - the register file and the ALU are all that is required. The ALU accepts its input from the DataRead ports of the register file, and the register file is written to by the ALUresult output of the ALU, in combination with the RegWrite signal.

- **Format:** `opcode r1, r2, r3`

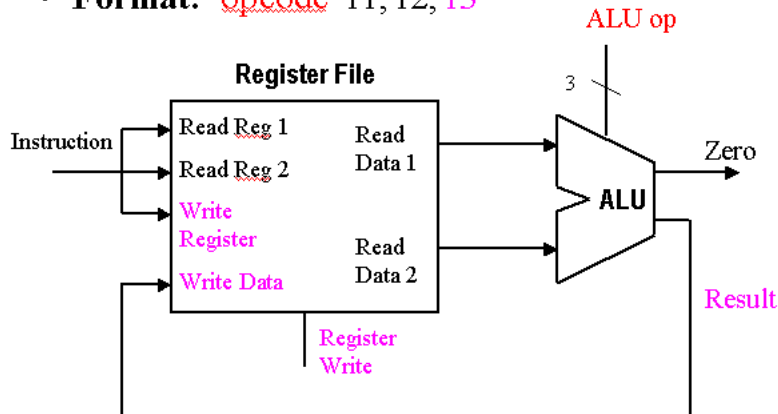

Figure 4.7. Schematic diagram R-format instruction datapath, adapted from [Maf01].

4.2.2. Load/Store Datapath

The load/store datapath uses instructions such as `lw $t1, offset($t2)`, where *offset* denotes a memory address offset applied to the base address in register `$t2`. The `lw` instruction reads from memory and writes into register `$t1`. The `sw` instruction reads from register `$t1` and writes into memory. In order to compute the memory address, the MIPS ISA specification says that we have to sign-extend the 16-bit offset to a 32-bit signed value. This is done using the sign extender shown in Figure 4.6.

The load/store datapath is illustrated in Figure 4.8, and performs the following actions in the order given:

1. *Register Access* takes input from the register file, to implement the instruction, data, or address *fetch* step of the fetch-decode-execute cycle.
2. *Memory Address Calculation* decodes the base address and offset, combining them to produce the actual memory address. This step uses the sign extender and ALU.
3. *Read/Write from Memory* takes data or instructions from the data memory, and implements the first part of the *execute* step of the fetch/decode/execute cycle.
4. *Write into Register File* puts data or instructions into the data memory, implementing the second part of the *execute* step of the fetch/decode/execute cycle.

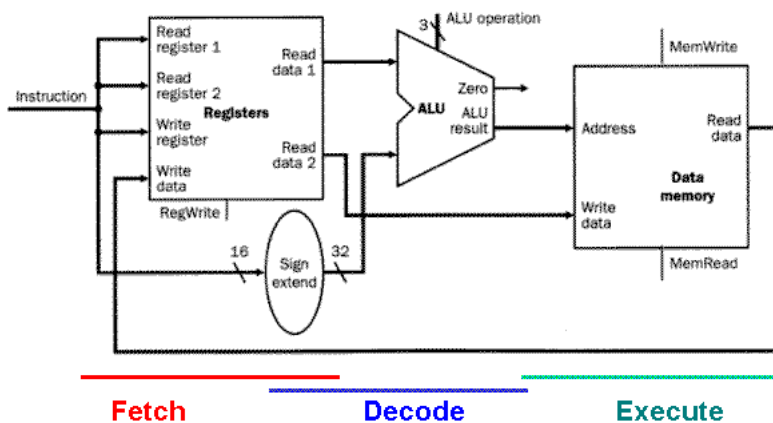

Figure 4.8. Schematic diagram of the Load/Store instruction datapath. Note that the *execute* step also includes writing of data back to the register file, which is not shown in the figure, for simplicity [MK98].

The load/store datapath takes operand #1 (the base address) from the register file, and sign-extends the offset, which is obtained from the instruction input to the register file. The sign-extended offset and the base address are combined by the ALU to yield the memory address, which is input to the Address port of the data memory. The MemRead signal is then activated, and the output data obtained from the ReadData port of the data memory is then written back to the Register File using its WriteData port, with RegWrite asserted.

4.2.3. Branch/Jump Datapath

The branch datapath (jump is an unconditional branch) uses instructions such as `beq $t1, $t2, offset`, where *offset* is a 16-bit offset for computing the branch target address via PC-relative addressing. The `beq` instruction reads from registers `$t1` and `$t2`, then compares the data obtained from these registers to see if they are equal. If equal, the branch is taken. Otherwise, the branch is not taken.

By *taking the branch*, the ISA specification means that the ALU adds a sign-extended offset to the program counter (PC). The offset is shifted left 2 bits to allow for word alignment (since $2^2 = 4$, and words are comprised of 4 bytes). Thus, to jump to the target address, the lower 26 bits of the PC are replaced with the lower 26 bits of the instruction shifted left 2 bits.

The branch instruction datapath is illustrated in Figure 4.9, and performs the following actions in the order given:

1. *Register Access* takes input from the register file, to implement the *instruction fetch* or *data fetch* step of the fetch-decode-execute cycle.
2. *Calculate Branch Target* - Concurrent with ALU #1's evaluation of the branch condition, ALU #2 calculates the branch target address, to be ready for the branch if it is taken. This completes the *decode* step of the fetch-decode-execute cycle.
3. *Evaluate Branch Condition and Jump to BTA or PC+4* uses ALU #1 in Figure 4.9, to determine whether or not the branch should be taken. Jump to BTA or PC+4 uses control logic hardware to transfer control to the instruction referenced by the branch target address. This effectively changes the PC to the branch target address, and completes the *execute* step of the fetch-decode-execute cycle.

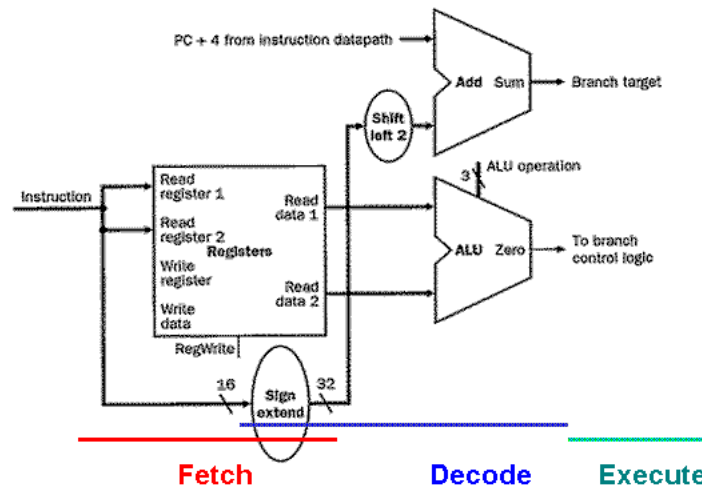

Figure 4.9. Schematic diagram of the Branch instruction datapath. Note that, unlike the Load/Store datapath, the *execute* step does not include writing of results back to the register file [MK98].

The branch datapath takes operand #1 (the offset) from the instruction input to the register file, then sign-extends the offset. The sign-extended offset and the program counter (incremented by 4 bytes to reference the next instruction after the branch instruction) are combined by ALU #1 to yield the branch target address. The operands for the branch condition to evaluate are concurrently obtained from the register file via the ReadData ports, and are input to ALU #2, which outputs a one or zero value to the branch control logic.

MIPS has the special feature of a *delayed branch*, that is, instruction I_b which follows the branch is always fetched, decoded, and prepared for execution. If the branch condition is false, a normal branch occurs. If the branch condition is true, then I_b is executed. One wonders why this extra work is performed - the answer is that delayed branch improves the efficiency of pipeline execution, as we shall see in Section 5. Also, the use of branch-not-taken (where I_b is executed) is sometimes the common case.

4.3. Single-Cycle and Multicycle Datapaths

Reading Assignments and Exercises

A single-cycle datapath executes in one cycle all instructions that the datapath is designed to implement. This clearly impacts CPI in a beneficial way, namely, $CPI = 1$ cycle for all instructions. In this section, we first examine the design discipline for implementing such a datapath using the hardware components and instruction-specific datapaths developed in Section 4.2. Then, we discover how the performance of a single-cycle datapath can be improved using a multi-cycle implementation.

4.3.2. Single Datapaths

Let us begin by constructing a datapath with control structures taken from the results of Section 4.2. The simplest way to connect the datapath components developed in Section 4.2 is to have them all execute an instruction concurrently, in one cycle. As a result, no datapath component can be used more than once per cycle, which implies duplication of components. To make this type of design more efficient without sacrificing speed, we can share a datapath component by allowing the component to have multiple inputs and outputs selected by a multiplexer.

The key to efficient single-cycle datapath design is to find commonalities among instruction types. For example, the R-format MIPS instruction datapath of Figure 4.7 and the load/store datapath of Figure 4.8 have similar register file and ALU connections. However, the following differences can also be observed:

1. The second ALU input is a register (R-format instruction) or a signed-extended lower 16 bits of the instruction (e.g., a load/store offset).
2. The value written to the register file is obtained from the ALU (R-format instruction) or memory (load/store instruction).

These two datapath designs can be combined to include separate instruction and data memory, as shown in Figure 4.10. The combination requires an adder and an ALU to respectively increment the PC and execute the R-format instruction.

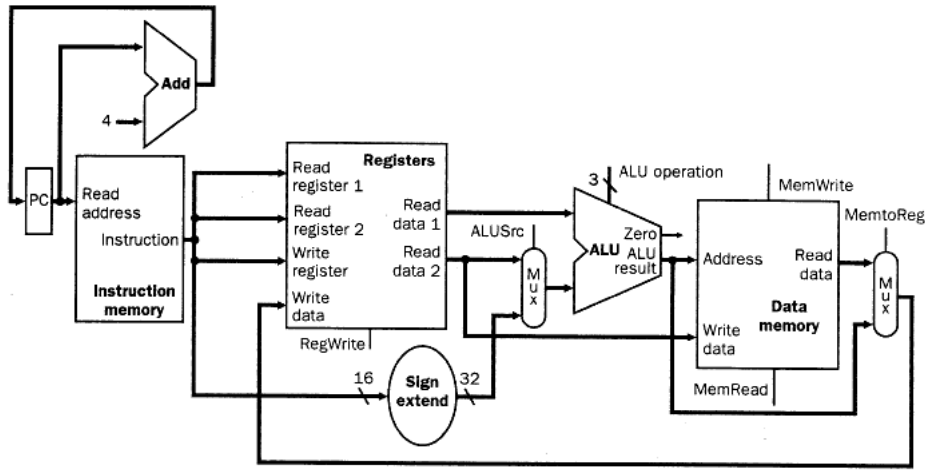

Figure 4.10. Schematic diagram of a composite datapath for R-format and load/store instructions [MK98].

Adding the branch datapath to the datapath illustrated in Figure 4.9 produces the augmented datapath shown in Figure 4.11. The branch instruction uses the main ALU to compare its operands and the adder computes the branch target address. Another multiplexer is required to select either the next instruction address (PC + 4) or the branch target address to be the new value for the PC.

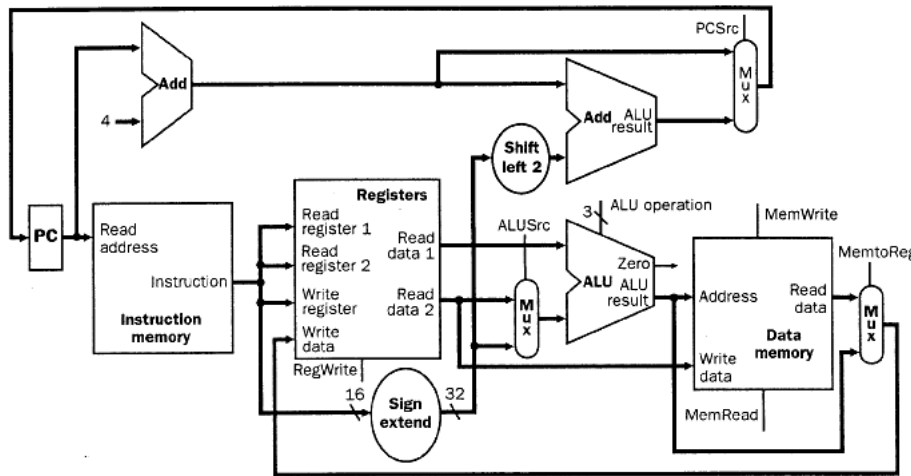

Figure 4.11. Schematic diagram of a composite datapath for R-format, load/store, and branch instructions [MK98].

4.3.1.1. ALU Control. Given the simple datapath shown in Figure 4.11, we next add the control unit. Control accepts inputs (called *control signals*) and generates (a) a write signal for each state element, (b) the control signals for each multiplexer, and (c) the ALU control signal. The ALU has three control signals, as shown in Table 4.1, below.

Table 4.1. ALU control codes

ALU Control Input	Function
000	and
001	or
010	add
110	sub
111	sll

The ALU is used for all instruction classes, and *always* performs one of the five functions in the right-hand column of Table 4.1. For branch instructions, the ALU performs a subtraction, whereas R-format instructions require one of the ALU functions. The ALU is controlled by two inputs: (1) the opcode from a MIPS instruction (six most significant bits), and (2) a two-bit control field (which Patterson and Hennessey call *ALUop*). The *ALUop* signal denotes whether the operation should be one of the following:

ALUop Input	Operation
00	load/store
01	beq
10	determined by opcode

The output of the ALU control is one of the 3-bit control codes shown in the left-hand column of Table 4.1. In Table 4.2, we show how to set the ALU output based on the instruction opcode and the *ALUop* signals. Later, we will develop a circuit for generating the *ALUop* bits. We call this approach *multi-level decoding* -- main control generates *ALUop* bits, which are input to ALU control. The ALU control then generates the three-bit codes shown in Table 4.1.

The advantage of a hierarchically partitioned or pipelined control scheme is realized in reduced hardware (several small control units are used instead of one large unit). This results in reduced hardware cost, and can in certain instances produce increased speed of control. Since the control unit is critical to datapath performance, this is an important implementational step.

Recall that we need to map the two-bit ALUop field and the six-bit opcode to a three-bit ALU control code. Normally, this would require $2^{(2+6)} = 256$ possible combinations, eventually expressed as entries in a truth table. However, only a few opcodes are to be implemented in the ALU designed herein. Also, the ALU is used only when $ALUop = 10_2$. Thus, we can use simple logic to implement the ALU control, as shown in terms of the truth table illustrated in Table 4.2.

Table 4.2. ALU control bits as a function of ALUop bits and opcode bits [MK98].

Instruction opcode	ALUOp	Instruction operation	Funct field	Desired ALU action	ALU control input
LW	00	load word	XXXXXX	add	010
SW	00	store word	XXXXXX	add	010
Branch equal	01	branch equal	XXXXXX	subtract	110
R-type	10	add	100000	add	010
R-type	10	subtract	100010	subtract	110
R-type	10	AND	100100	and	000
R-type	10	OR	100101	or	001
R-type	10	set on less than	101010	set on less than	111

In this table, an "X" in the input column represents a "don't-care" value, which indicates that the output does not depend on the input at the *i*-th bit position. The preceding truth table can be optimized and implemented in terms of gates, as shown in Section C.2 of Appendix C of the [textbook](#).

4.3.1.2. Main Control Unit. The first step in designing the main control unit is to identify the fields of each instruction and the required control lines to implement the datapath shown in Figure 4.11.

Recalling the three MIPS instruction formats (R, I, and J), shown as follows:

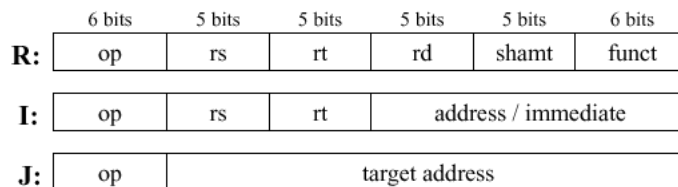

op: basic operation of the instruction (opcode)
rs: first source operand register
rt: second source operand register
rd: destination operand register
shamt: shift amount
funct: selects the specific variant of the opcode (function code)
address: offset for load/store instructions ($\pm 2^{15}$)
immediate: constants for immediate instructions

Observe that the following always apply:

- **Bits 31-26:** *opcode* - always at this location
- **Bits 25-21 and 20-16:** *input register indices* - always at this location

Additionally, we have the following instruction-specific codes due to the regularity of the MIPS instruction format:

- **Bits 25-21:** *base register* for load/store instruction - always at this location
- **Bits 15-0:** *16-bit offset* for branch instruction - always at this location
- **Bits 15-11:** *destination register* for R-format instruction - always at this location
- **Bits 20-16:** *destination register* for load/store instruction - always at this location

Note that the different positions for the two destination registers implies a selector (i.e., a mux) to locate the appropriate field for each type of instruction. Given these constraints, we can add to the simple datapath thus far developed instruction labels and an extra multiplexer for the WriteReg input of the register file, as shown in Figure 4.12.

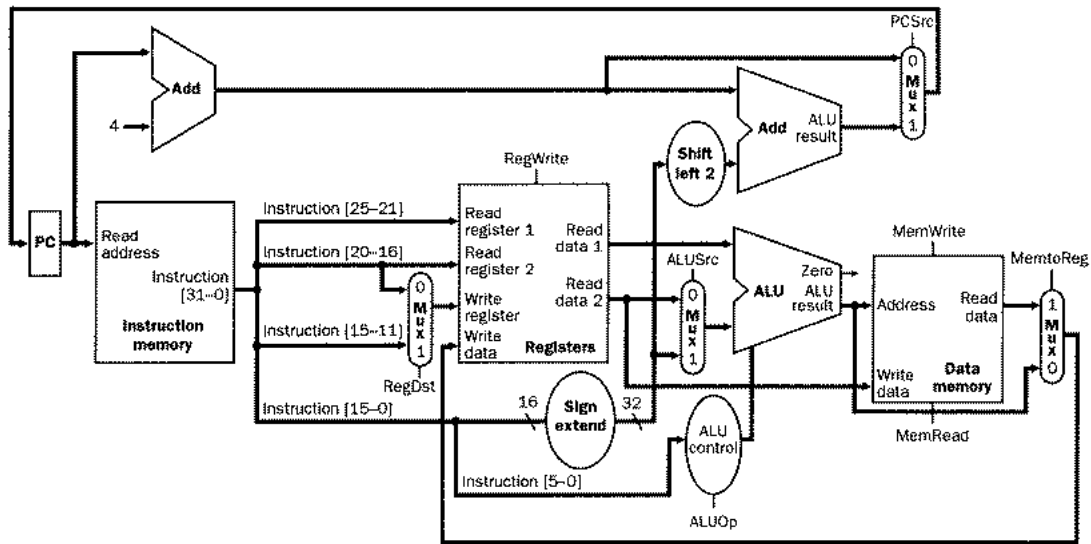

Figure 4.12. Schematic diagram of composite datapath for R-format, load/store, and branch instructions (from Figure 4.11) with control signals and extra multiplexer for WriteReg signal generation [MK98].

Here, we see the seven-bit control lines (six-bit opcode with one-bit WriteReg signal) together with the two-bit ALUOp control signal, whose actions when asserted or deasserted are given as follows:

- **RegDst**

Deasserted: Register destination number for the Write register is taken from bits 20-16 (rt field) of the instruction

Asserted: Register destination number for the Write register is taken from bits 15-11 (rd field) of the instruction

- **RegWrite**

Deasserted: No action

Asserted: Register on the WriteRegister input is written with the value on the WriteData input

- **ALUSrc**

Deasserted: The second ALU operand is taken from the second register file output (ReadData 2)

Asserted: the second alu operand is the sign-extended, lower 16 bits of the instruction

- **PCSrc**

Deasserted: PC is overwritten by the output of the adder ($PC + 4$)

Asserted: PC overwritten by the branch target address

- **MemRead**

Deasserted: No action

Asserted: Data memory contents designated by address input are present at the ReadData output

- **MemWrite**

Deasserted: No action

Asserted: Data memory contents designated by address input are present at the WriteData input

- **RegWrite**

Deasserted: The value present at the WriteData input is output from the ALU

Asserted: The value present at the register WriteData input is taken from data memory

Given only the opcode, the control unit can thus set all the control signals except PCSrc, which is only set if the instruction is beq and the Zero output of the ALU used for comparison is true. PCSrc is generated by *and*-ing a Branch signal from the control unit with the Zero signal from the ALU. Thus, all control signals can be set based on the opcode bits. The resultant datapath and its signals are shown in detail in Figure 4.13.

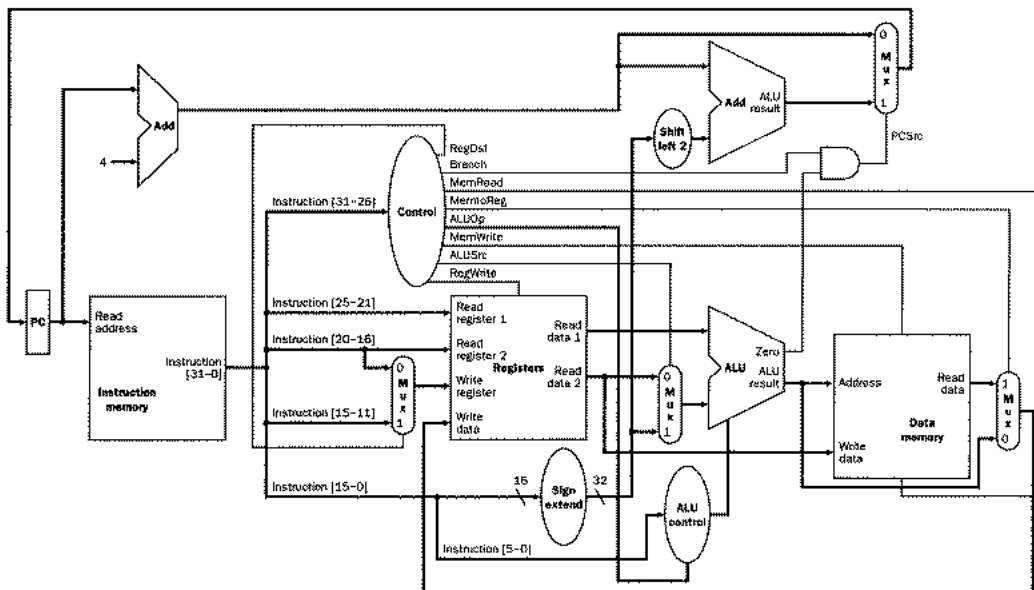

Figure 4.13. Schematic diagram of composite datapath for R-format, load/store, and branch instructions (from Figure 4.12) with control signals illustrated in detail [MK98].

We next examine functionality of the datapath illustrated in 4.13, for the three major types of instructions, then discuss how to augment the datapath for a new type of instruction.

4.3.2. Datapath Operation

Recall that there are three MIPS instruction formats -- R, I, and J. Each instruction causes slightly different functionality to occur along the datapath, as follows.

4.3.2.1. R-format Instruction. Execution of an R-format instruction (e.g., `add $t1, $t0, $t1`) using the datapath developed in Section 4.3.1 involves the following steps:

1. Fetch instruction from instruction memory and increment PC
2. Input registers (e.g., `$t0` and `$t1`) are read from the register file
3. ALU operates on data from register file using the *funct* field of the MIPS instruction (Bits 5-0) to help select the ALU operation
4. Result from ALU written into register file using bits 15-11 of instruction to select the destination register (e.g., `$t1`).

Note that this implementational sequence is actually combinational, because of the single-cycle assumption. Since the datapath operates within one clock cycle, the signals stabilize approximately in the order shown in Steps 1-4, above.

4.3.2.2. Load/Store Instruction. Execution of a load/store instruction (e.g., `lw $t1, offset($t2)`) using the datapath developed in Section 4.3.1 involves the following steps:

1. Fetch instruction from instruction memory and increment PC
2. Read register value (e.g., base address in `$t2`) from the register file
3. ALU adds the base address from register `$t2` to the sign-extended lower 16 bits of the instruction (i.e., *offset*)
4. Result from ALU is applied as an address to the data memory
5. Data retrieved from the memory unit is written into the register file, where the register index is given by `$t1` (Bits 20-16 of the instruction).

4.3.2.3. Branch Instruction. Execution of a branch instruction (e.g., `beq $t1, $t2, offset`) using the datapath developed in Section 4.3.1 involves the following steps:

1. Fetch instruction from instruction memory and increment PC
2. Read registers (e.g., `$t1` and `$t2`) from the register file. The adder sums `PC + 4` plus sign-extended lower 16 bits of *offset* shifted left by two bits, thereby producing the branch target address (BTA).
3. ALU subtracts contents of `$t1` minus contents of `$t2`. The Zero output of the ALU directs which result (`PC+4` or BTA) to write as the new PC.

4.3.2.4. Final Control Design. Now that we have determined the actions that the datapath must perform to compute the three types of MIPS instructions, we can use the information in Table 4.3 to describe the control logic in terms of a truth table. This truth table (Table 4.3) is optimized as shown in Section C.2 of Appendix C of the [textbook](#) to yield the datapath control circuitry.

Table 4.3. ALU control bits as a function of ALUop bits and opcode bits [MK98].

Input or output	Signal name	R-format	lw	sw	beq
Inputs	Op5	0	1	1	0
	Op4	0	0	0	0
	Op3	0	0	1	0
	Op2	0	0	0	1
	Op1	0	1	1	0
	Op0	0	1	1	0
Outputs	RegDst	1	0	X	X
	ALUSrc	0	1	1	0
	MemtoReg	0	1	X	X
	RegWrite	1	1	0	0
	MemRead	0	1	0	0
	MemWrite	0	0	1	0
	Branch	0	0	0	1
	ALUOp1	1	0	0	0
ALUOp0	0	0	0	1	

4.3.3. Extended Control for New Instructions

The jump instruction provides a useful example of how to extend the single-cycle datapath developed in Section 4.3.2, to support new instructions. Jump resembles branch (a conditional form of the jump instruction), but computes the PC differently and is unconditional. Identical to the branch target address, the lowest two bits of the jump target address (JTA) are always zero, to preserve word alignment. The next 26 bits are taken from a 26-bit immediate field in the jump instruction (the remaining six bits are reserved for the opcode). The upper four bits of the JTA are taken from the upper four bits of the next instruction (PC + 4). Thus, the JTA computed by the jump instruction is formatted as follows:

- **Bits 31-28:** Upper four bits of (PC + 4)
- **Bits 27-02:** Immediate field of jump instruction
- **Bits 01-00:** Zero (00₂)

The jump is implemented in hardware by adding a control circuit to Figure 4.13, which is comprised of:

- An additional multiplexer, to select the source for the new PC value. To cover all cases, this source is PC+4, the conditional BTA, or the JTA.
- An additional control signal for the new multiplexer, asserted only for a jump instruction (opcode = 2).

The resulting augmented datapath is shown in Figure 4.14.

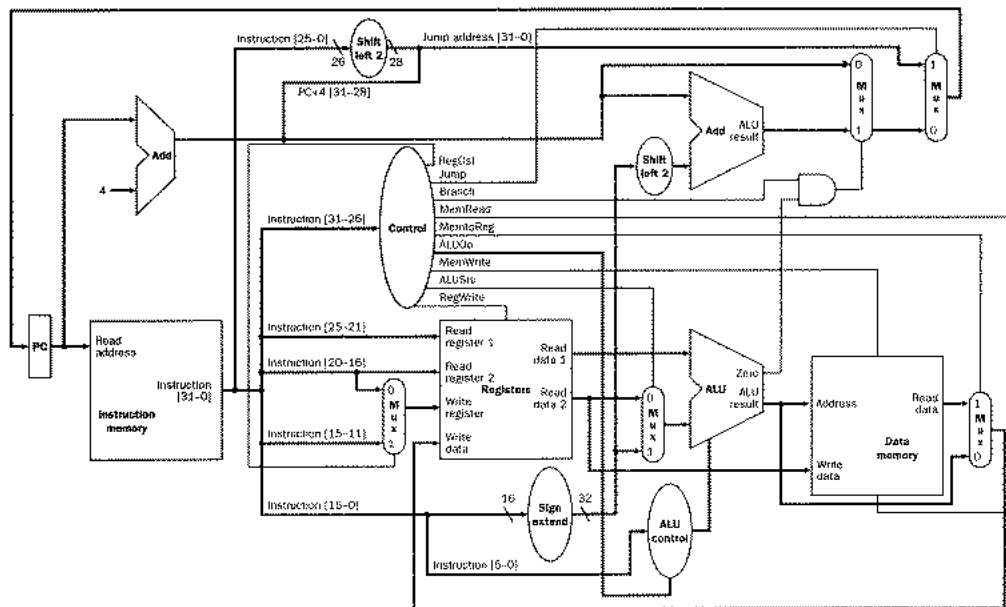

Figure 4.14. Schematic diagram of composite datapath for R-format, load/store, branch, and jump instructions, with control signals labelled [MK98].

4.3.4. Limitations of the Single-Cycle Datapath

The single-cycle datapath is not used in modern processors, because it is inefficient. The critical path (longest propagation sequence through the datapath) is five components for the load instruction. The cycle time t_c is limited by the settling time t_s of these components. For a circuit with no feedback loops, $t_c > 5t_s$. In practice, $t_c = 5kt_s$, with large proportionality constant k , due to feedback loops, delayed settling due to circuit noise, etc. Additionally, as shown in the table

on p. 374 of the [textbook](#), it is possible to compute the required execution time for each instruction class from the critical path information. The result is that the Load instruction takes 5 units of time, while the Store and R-format instructions take 4 units of time. All the other types of instructions that the datapath is designed to execute run faster, requiring three units of time.

The problem of penalizing addition, subtraction, and comparison operations to accommodate loads and stores leads one to ask if multiple cycles of a much faster clock could be used for each part of the fetch-decode-execute cycle. In practice, this technique is employed in CPU design and implementation, as discussed in the following sections on multicycle datapath design. In Section 5, we will show that datapath actions can be *interleaved* in time to yield a potentially fast implementation of the fetch-decode-execute cycle that is formalized in a technique called *pipelining*.

4.3.5. Multicycle Datapath Design

In Sections 4.3.1 through 4.3.4, we designed a single-cycle datapath by (1) grouping instructions into classes, (2) decomposing each instruction class into constituent operations, and (3) deriving datapath components for each instruction class that implemented these operations. In this section, we use the single-cycle datapath components to create a multi-cycle datapath, where each step in the fetch-decode-execute sequence takes one cycle. This approach has two advantages over the single-cycle datapath:

1. Each functional unit (e.g., Register File, Data Memory, ALU) can be used more than once in the course of executing an instruction, which saves hardware (and, thus, reduces cost); and
2. Each instruction step takes one cycle, so different instructions have different execution times. In contrast, the single-cycle datapath that we designed previously required every instruction to take one cycle, so all the instructions move at the speed of the slowest.

We next consider the basic differences between single-cycle and multi-cycle datapaths.

4.3.5.1. Cursory Analysis. Figure 4.15 illustrates a simple multicycle datapath. Observe the following differences between a single-cycle and multi-cycle datapath:

- In the multicycle datapath, one memory unit stores both instructions and data, whereas the single-cycle datapath requires separate instruction and data memories.
- The multicycle datapath uses one ALU, versus an ALU and two adders in the single-cycle datapath, because signals can be rerouted through the ALU in a multicycle implementation.
- In the single-cycle implementation, the instruction executes in one cycle (by design) and the outputs of all functional units must stabilize within one cycle. In contrast, the multicycle implementation uses one or more registers to temporarily store (buffer) the ALU or functional unit outputs. This *buffering* action stores a value in a temporary register until it is needed or used in a subsequent clock cycle.

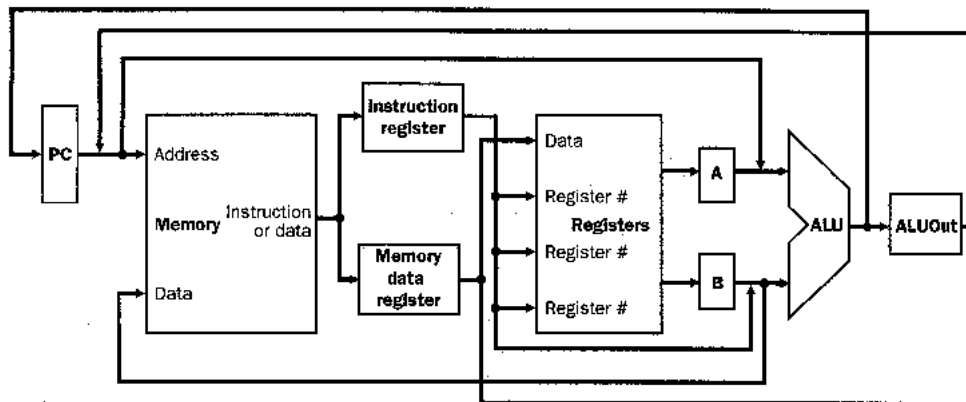

Figure 4.15. Simple multicycle datapath with buffering registers (Instruction register, Memory data register, A, B, and ALUOut) [MK98].

Note that there are two types of *state elements* (e.g., memory, registers), which are:

1. *Programmer-Visible* (register file, PC, or memory), in which data is stored that is used by subsequent instructions (in a later clock cycle); and
2. *Additional State Elements* (buffer registers), in which data is stored that is used in a later clock cycle of the same instruction.

Thus, the additional (buffer) registers determine (a) what functional units will fit into a given clock cycle and (b) the data required for later cycles involved in executing the current instruction. In the simple implementation presented herein, we assume for purposes of illustration that each clock cycle can accommodate one and only one of the following operations:

- Memory access
- Register file access (two reads or one write)
- ALU operation (arithmetic or logical)

4.3.5.2. New Registers. As a result of buffering, data produced by memory, register file, or ALU is saved for use in a subsequent cycle. The following temporary registers are important to the multicycle datapath implementation discussed in this section:

- *Instruction Register* (IR) saves the data output from the Text Segment of memory for a subsequent instruction read;
- *Memory Data Register* (MDR) saves memory output for a data read operation;
- *A and B Registers* (A,B) store ALU operand values read from the register file; and
- *ALU Output Register* (ALUOut) contains the result produced by the ALU.

The IR and MDR are distinct registers because some operations require both instruction and data in the same clock cycle. Since all registers except the IR hold data only between two adjacent clock cycles, these registers do not need a write control signal. In contrast, the IR holds an instruction until it is executed (multiple clock cycles) and therefore requires a write control signal to protect the instruction from being overwritten before its execution has been completed.

4.3.5.3. New Muxes. we also need to add new multiplexers and expand existing ones, to implement sharing of functional units. For example, we need to select between memory address as PC (for a load instruction) or ALUout (for load/store instructions). The muxes also route to one ALU the many inputs and outputs that were distributed among the several ALUs of the single-cycle datapath. Thus, we make the following additional changes to the single-cycle datapath:

- Add a multiplexer to the first ALU input, to choose between (a) the A register as input (for R- and I-format instructions) , or (b) the PC as input (for branch instructions).
- On the second ALU, the input is selected by a four-way mux (two control bits). The two additional inputs to the mux are (a) the immediate (constant) value 4 for incrementing the PC and (b) the sign-extended offset, shifted two bits to preserve alignment, which is used in computing the branch target address.

The details of these muxes are shown in Figure 4.16. By adding a few registers (buffers) and muxes (inexpensive widgets), we halve the number of memory units (expensive hardware) and eliminate two adders (more expensive hardware).

4.3.5.4. New Control Signals. The datapath shown in Figure 4.16 is multicycle, since it uses multiple cycles per instruction. As a result, it will require different control signals than the single-cycle datapath, as follows:

- *Write Control Signals* for the IR and programmer-visible state units
- *Read Control Signal* for the memory; and
- *Control Lines* for the muxes.

It is advantageous that the ALU control from the single-cycle datapath can be used as-is for the multicycle datapath ALU control. However, some modifications are required to support branches and jumps. We describe these changes as follows.

4.3.5.5. Branch and Jump Instruction Support. To implement branch and jump instructions, one of three possible values is written to the PC:

1. *ALU output* = PC + 4, to get the next instruction during the instruction fetch step (to do this, PC + 4 is written directly to the PC)
2. *Register ALUout*, which stores the computed branch target address.
3. *Lower 26 bits (offset) of the IR*, shifted left by two bits (to preserve alignment) and concatenated with the upper four bits of PC+4, to form the jump target address.

The PC is written unconditionally (jump instruction) or conditionally (branch), which implies two control signals - PCWrite and PCWriteCond. From these two signals and the Zero output of the ALU, we derive the PCWrite control signal, via the following logic equation:

$$\text{PCWriteControl} = (\text{ALUZero and PCWriteCond}) \text{ or } \text{PCWrite},$$

where (a) ALUZero indicates if two operands of the beq instruction are equal and (b) the result of (ALUZero and PCWriteCond) determines whether the PC should be written during a conditional branch. We call the latter the *branch taken* condition. Figure 4.16 shows the resultant multicycle datapath and control unit with new muxes and corresponding control signals. Table 4.4 illustrates the control signals and their functions.

4.3.6. Multicycle Datapath and Instruction Execution

Given the datapath illustrated in Figure 4.16, we examine instruction execution in each cycle of the datapath. The implementational goal is balancing of the work performed per clock cycle, to minimize the average time per cycle across all instructions. For example, each step would contain one of the following:

- ALU operation
- Register file access (two reads or one write)
- Memory access (one read or one write)

Thus, the cycle time will be equal to the maximum time required for any of the preceding operations.

Note: Since (a) the datapath is designed to be edge-triggered (reference Section 4.1.1) and (b) the outputs of ALU, register file, or memory are stored in dedicated registers (buffers), we can continue to read the value stored in a dedicated register. The new value, output from ALU, register file, or memory, is not available in the register until the next clock cycle.

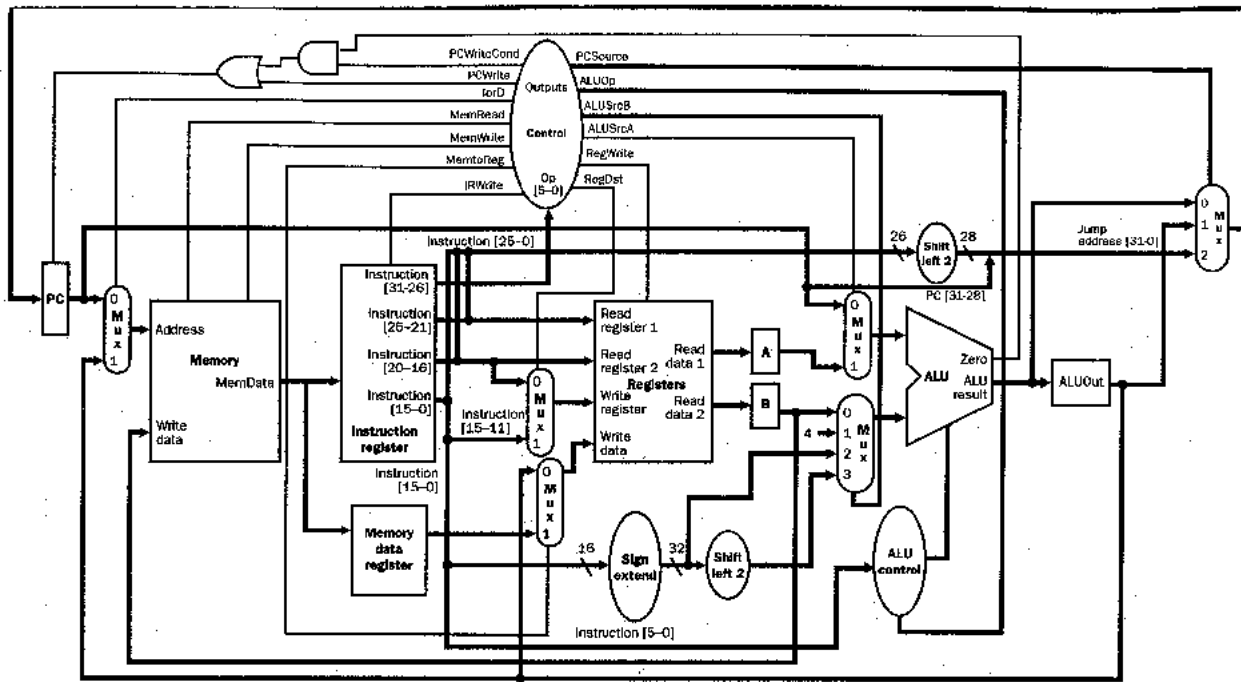

Figure 4.16. MIPS multicycle datapath [MK98].

Table 4.4. Multicycle datapath control signals and their functions [MK98].

Actions of the 1-bit control signals

Signal name	Effect when deasserted	Effect when asserted
RegDst	The register file destination number for the Write register comes from the rt field.	The register file destination number for the Write register comes from the rd field.
RegWrite	None	The general-purpose register selected by the Write register number is written with the value of the Write data input.
ALUSrcA	The first ALU operand is the PC.	The first ALU operand comes from the A register.
MemRead	None	Content of memory at the location specified by the Address input is put on Memory data output.
MemWrite	None	Memory contents at the location specified by the Address input is replaced by value on Write data input.
MemtoReg	The value fed to the register file Write data input comes from ALUOut.	The value fed to the register file Write data input comes from the MDR.
lorD	The PC is used to supply the address to the memory unit.	ALUOut is used to supply the address to the memory unit.
IRWrite	None	The output of the memory is written into the IR.
PCWrite	None	The PC is written; the source is controlled by PCSource.
PCWriteCond	None	The PC is written if the Zero output from the ALU is also active.

Actions of the 2-bit control signals

Signal name	Value	Effect
ALUOp	00	The ALU performs an add operation.
	01	The ALU performs a subtract operation.
	10	The funct field of the instruction determines the ALU operation.
ALUSrcB	00	The second input to the ALU comes from the B register.
	01	The second input to the ALU is the constant 4.
	10	The second input to the ALU is the sign-extended, lower 16 bits of the IR.
	11	The second input to the ALU is the sign-extended, lower 16 bits of the IR shifted left 2 bits.
PCSource	00	Output of the ALU (PC + 4) is sent to the PC for writing.
	01	The contents of ALUOut (the branch target address) are sent to the PC for writing.
	10	The jump target address (IR[25-0] shifted left 2 bits and concatenated with PC + 4[31-28]) is sent to the PC for writing.

In the multicycle datapath, all operations within a clock cycle occur in parallel, but successive steps within a given instruction operate sequentially. Several implementational issues present that do not confound this view, but should be discussed. One must distinguish between (a) reading/writing the PC or one of the buffer registers, and (b) reads/writes to the register file. Namely, I/O to the PC or buffers is part of one clock cycle, i.e., we get this essentially "for free" because of the clocking scheme and hardware design. In contrast, the register file has more complex hardware (as shown in Section 4.1.2) and requires a dedicated clock cycle for its circuitry to stabilize.

We next examine multicycle datapath execution in terms of the fetch-decode-execute sequence.

4.3.6.1. Instruction Fetch. In this first cycle that is common to all instructions, the datapath fetches an instruction from memory and computes the new PC (address of next instruction in the program sequence), as represented by the following pseudocode:

```

IR = Memory[PC]      # Put contents of Memory[PC] in Instr.Register
PC = PC + 4          # Increment the PC by 4 to preserve alignment

```

where IR denotes the instruction register.

The PC is sent (via control circuitry) as an address to memory. The memory hardware performs a read operation and control hardware transfers the instruction at Memory[PC] into the IR, where it is stored until the next instruction is fetched. Then, the ALU increments the PC by four to preserve word alignment. The incremented (new) PC value is stored back into the PC register by setting PCSource = 00 and asserting PCWrite. Fortunately, incrementing the PC and performing the memory read are concurrent operations, since the new PC is not required (at the earliest) until the next clock cycle.

Reading Assignment: The exact sequence of operations is described on p.385 of the textbook.

4.3.6.2. Instruction Decode and Data Fetch. Included in the multicycle datapath design is the assumption that the actual opcode to be executed is not known prior to the instruction decode step. This is reasonable, since the new instruction is not yet available until completion of instruction fetch and has thus not been decoded.

As a result of not knowing what operation the ALU is to perform in the current instruction, the datapath must execute *only* actions that are:

- Applicable to *all* instructions and
- Not harmful to *any* instruction.

Therefore, given the *rs* and *rt* fields of the MIPS instruction format (per Figure 2.7), we can suppose (harmlessly) that the next instruction will be R-format. We can thus read the operands corresponding to *rs* and *rt* from the register file. If we don't need one or both of these operands, that is not harmful. Otherwise, the register file read operation will place them in buffer registers A and B, which is also not harmful.

Another action the datapath can perform is computation of the branch target address using the ALU, since this is the instruction *decode* step and the ALU is not yet needed for instruction execution. If the instruction that we are decoding in this step is not a branch, then no harm is done - the BTA is stored in ALUout and nothing further happens to it.

We can perform these preparatory actions because of the of MIPS instruction formats. The result is represented in pseudocode, as follows:

```

A = RegFile[IR[25:21]] # First operand = Bits 25-21 of instruction
B = RegFile[IR[20:16]] # Second operand = Bits 25-21 of instruction
ALUout = PC + SignExtend(IR[15:0]) << 2 ; # Compute BTA

```

where "x << n" denotes x shifted left by n bits.

Reading Assignment: The exact sequence of low-level operations is described on p.384 of the textbook.

4.3.6.3. Instruction Execute, Address Computation, or Branch Completion. In this cycle, we know what the instruction is, since decoding was completed in the previous cycle. The instruction opcode determines the datapath operation, as in the single-cycle datapath. The ALU operates upon the operands prepared in the decode/data-fetch step (Section 4.3.6.2), performing one of the following actions:

- *Memory Reference:* ALUout = A + SignExtend(IR[15:0])

The ALU constructs the memory address from the base address (stored in A) and the offset (taken from the low 16 bits of the IR). Control signals are set as described on p. 387 of the textbook.

- *R-format Instruction:* ALUout = A op B

The ALU takes its inputs from buffer registers A and B and computes a result according to control signals specified by the instruction opcode, function field, and control signals ALUop = 10. The control signals are further described on p. 387 of the textbook.

- *Branch:* if (A == B) then PC = ALUout

In branch instructions, the ALU performs the comparison between the contents of registers A and B. If A = B, then the Zero output of the ALU is asserted, the PC is updated (overwritten) with (1) the BTA computed in the preceding step (per Section 4.3.6.2), then (2) the ALUout value. If the branch is not taken, then the PC+4 value computed during instruction fetch (per Section 4.3.6.1) is used. This covers all possibilities by using for the BTA the value most recently written into the PC. Salient hardware control actions are discussed on p. 387 of the textbook.

- *Jump:* PC = PC[31:28] || (IR[25:0] << 2)

Here, the PC is replaced by the jump target address, which does not need the ALU be computed, but can be formed in hardware as described on p. 387 of the textbook.

4.3.6.4. Memory Access or R-format Instruction Completion. In this cycle, a load-store instruction accesses memory and an R-format instruction writes its result (which appears at ALUout at the end of the previous cycle), as follows:

```

MDR = Memory[ALUout] # Load
Memory[ALUout] = B   # Store

```

where MDR denotes the memory data register.

Reading Assignment: The control actions for load/store instructions are discussed on p.388 of the textbook.

For an R-format completion, where

```

Reg[IR[15:11]] = ALUout # Write ALU result to register file

```

the data to be loaded was stored in the MDR in the previous cycle and is thus available for this cycle. The *rt* field of the MIPS instruction format (Bits 20-16) has the register number, which is applied to the input of the register file, together with RegDst = 0 and an asserted RegWrite signal.

Reading Assignment: The exact sequence of operations is described on p.385 of the textbook.

From the preceding sequences as well as their discussion in the textbook, we are prepared to design a finite-state controller, as shown in the following section.

4.4. Finite State Control

Reading Assignments and Exercises

In the single-cycle datapath control, we designed control hardware using a set of truth tables based on control signals activated for each instruction class. However, this approach must be modified for the multicycle datapath, which has the additional dimension of time due to the stepwise execution of instructions. Thus, the multicycle datapath control is dependent on the current step involved in executing an instruction, as well as the next step.

There are two alternative techniques for implementing multicycle datapath control. First, a *finite-state machine* (FSM) or *finite state control* (FSC) predicts actions appropriate for datapath's next computational step. This prediction is based on (a) the status and control information specific to the datapath's current step and (b) actions to be performed in the next step. A second technique, called *microprogramming*, uses a programmatic representation to implement control, as discussed in Section 4.5. Appendix C of the textbook shows how these representations are translated into hardware.

4.4.1. Finite State Machine

An FSM consists of a set of states with directions that tell the FSM how to change states. The following features are important:

- Current state and inputs;
- Next-state function, also called the *transition function*, which converts inputs to (a) a new state, and (b) outputs of the FSM; and
- Outputs, which in the case of the multicycle datapath, are control signals that are asserted when the FSM is in a given state.

Implementationally, we assume that all outputs not explicitly asserted are deasserted. Additionally, all multiplexer controls are explicitly specified if and only if they pertain to the current and next states. A simple example of an FSM is given in Appendix B of the textbook.

4.4.2. Finite State Control

The FSC is designed for the multicycle datapath by considering the five steps of instruction execution given in Section 4.3, namely:

1. Instruction fetch
2. Instruction decode and data fetch
3. ALU operation
4. Memory access or R-format instruction completion
5. Memory access completion

Each of these steps takes one cycle, by definition of the multicycle datapath. Also, each step stores its results in temporary (buffer) registers such as the IR, MDR, A, B, and ALUout. Each state in the FSM will thus (a) occupy one cycle in time, and (b) store its results in a temporary (buffer) register.

From the discussion of Section 4.3, observe that Steps 1 and 2 are identical for every instruction, but Steps 3-5 differ, depending on instruction format. Also note that after completion of an instruction, the FSC returns to its initial state (Step 1) to fetch another instruction, as shown in Figure 4.17.

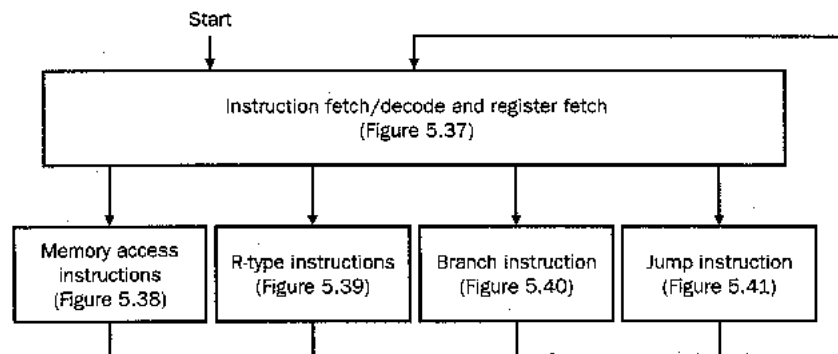

Figure 4.17. High-level (abstract) representation of finite-state machine for the multicycle datapath finite-state control. Figure numbers refer to figures in the textbook [Pat98,MK98].

Let us begin our discussion of the FSC by expanding steps 1 and 2, where State 0 (the initial state) corresponds to Step 1.

4.4.2.1. Instruction Fetch and Decode. In Figure 4.18 is shown the FSM representation for instruction fetch and decode. The control signals asserted in each state are shown within the circle that denotes a given state. The edges (lines or arrows) between states are labelled with the conditions that must be fulfilled for the illustrated transition between states to occur. Patterson and Hennessey call the process of branching to different states *decoding*, which depends on the instruction class after State 1 (i.e., Step 2, as listed above).

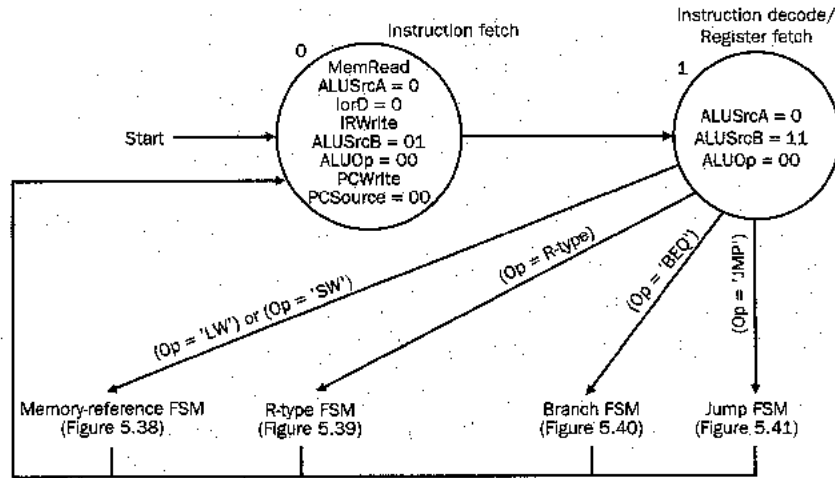

Figure 4.18. Representation of finite-state control for the instruction fetch and decode states of the multicycle datapath. Figure numbers refer to figures in the textbook [Pat98,MK98].

4.4.2.2. **Memory Reference.** The memory reference portion of the FSC is shown in Figure 4.19. Here, State 2 computes the memory address by setting ALU input muxes to pass the A register (base address) and sign-extended lower 16 bits of the offset (shifted left two bits) to the ALU. After address computation, memory read/write requires two states:

- **State 3:** Performs memory access by asserting the MemRead signal, putting memory output into the MDR.
- **State 5:** Activated if sw (store word) instruction is used, and MemWrite is asserted.

In both states, the memory is forced to equal ALUout, by setting the control signal IorD = 1.

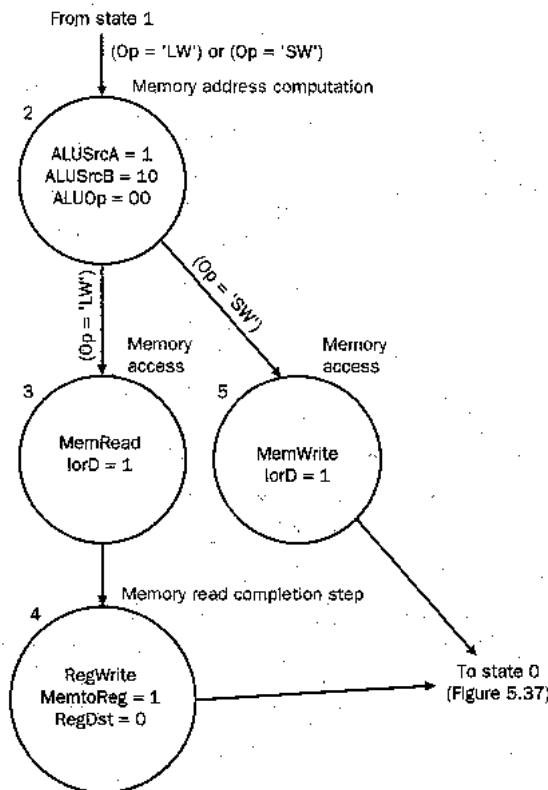

Figure 4.19. Representation of finite-state control for the memory reference states of the multicycle datapath. Figure numbers refer to figures in the textbook [Pat98,MK98].

When State 5 completes, control is transferred to State 0. Otherwise, State 3 completes and the datapath must finish the load operation, which is accomplished by transferring control to State 4. There, MemtoReg = 1, RegDst = 0, and the MDR contents are written to the register file. The next state is State 0.

4.4.2.3. **R-format Execution.** To implement R-format instructions, FSC uses two states, one for execution (Step 3) and another for R-format completion (Step 4), per Figure 4.20. State 6 asserts ALUSrcA and sets ALUSrcB = 00, which loads the ALU's A and B input registers from register file outputs. The ALUOp = 10 setting causes the ALU control to use the instruction's *funct* field to set the ALU control signals to implement the designated ALU operation.

State 7 causes (a) the register file to write (assert RegWrite), (b) *rd* field of the instruction to have the number of the destination register (assert RegDst), and (c) ALUout selected as having the value that must be written back to the register file as the result of the ALU operation (by deasserting MemtoReg).

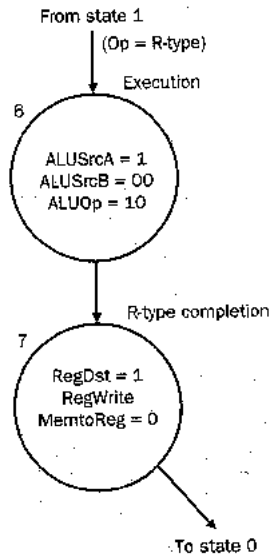

Figure 4.20. Representation of finite-state control for the R-format instruction execution states of the multicycle datapath. Figure numbers refer to figures in the textbook [Pat98,MK98].

4.4.2.4. Branch Control. Since branches complete during Step 3, only one new state is needed. In State 8, (a) control signals that cause the ALU to compare the contents of its A and B input registers are set (i.e., ALUSrcA = 1, ALUSrcB = 00, ALUOp = 01), and (b) the PC is written conditionally (by setting PCSrc = 01 and asserting PCWriteCond). Note that setting ALUOp = 01 forces a subtraction, hence only the beq instruction can be implemented this way.

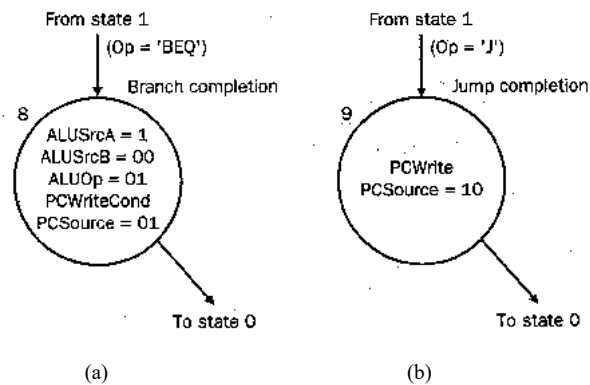

Figure 4.21. Representation of finite-state control for (a) branch and (b) jump instruction-specific states of the multicycle datapath. Figure numbers refer to figures in the textbook [Pat98,MK98].

4.4.2.5. Jump Instruction. Similar to branch, the jump instruction requires only one state (#9) to complete execution. Here, the PC is written by asserting PCWrite. The value written to the PC is the lower 26 bits of the IR with the upper four bits of PC, and the lower two bits equal to 00_2 . This is done by setting PCSrc = 10_2 .

4.4.3. FSC and Multicycle Datapath Performance

The composite FSC is shown in Figure 4.22, which was constructed by composing Figures 4.18 through 4.21.

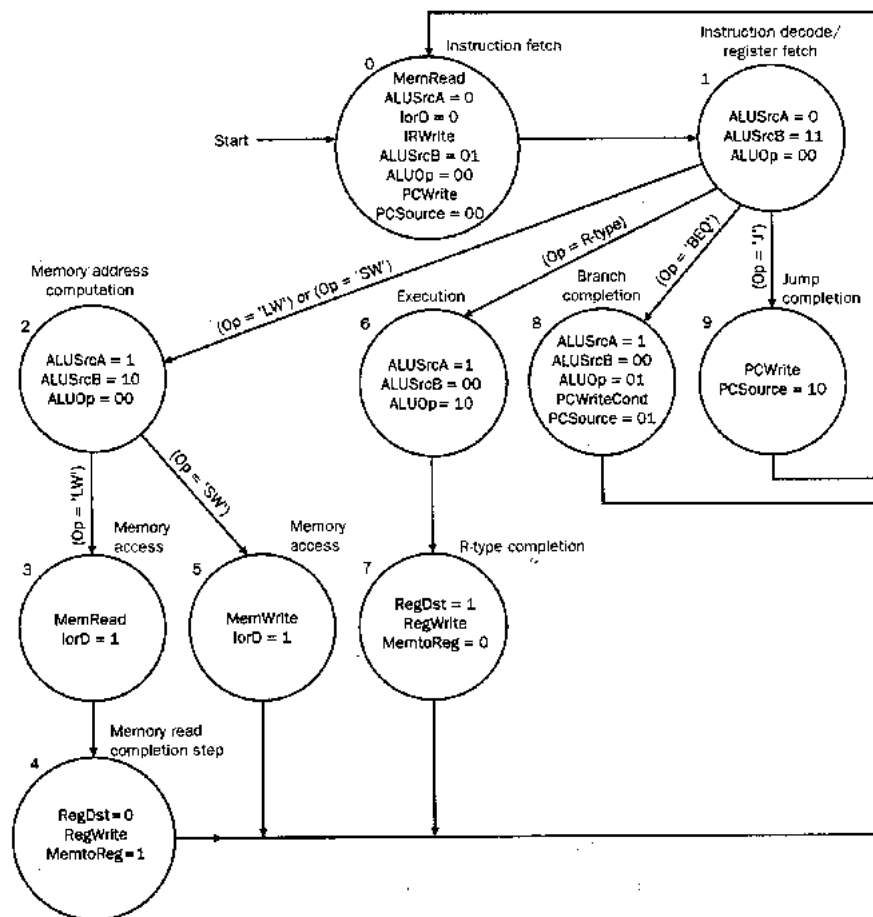

Figure 4.22. Representation of the composite finite-state control for the MIPS multicyle datapath [MK98].

When computing the performance of the multicyle datapath, we use this FSM representation to determine the critical path (maximum number of states encountered) for each instruction type, with the following results:

- Load: 5 states
- Store: 4 states
- R-format ALU instructions: 4 states
- Branch: 3 states
- Jump: 3 states

Since each state corresponds to a clock cycle (according to the design assumption of the FSC controller in Section 4.4.2), we have the following expression for CPI of the multicyle datapath:

$$\text{CPI} = [\# \text{Loads} \cdot 5 + \# \text{Stores} \cdot 4 + \# \text{ALU-instr's} \cdot 4 + \# \text{Branches} \cdot 3 + \# \text{Jumps} \cdot 3] / (\text{Total Number of Instructions})$$

Reading Assignment: Know in detail the example computation of CPI for the multicyle datapath, beginning on p.397 of the textbook.

The textbook example shows CPI for the gcc benchmark is 4.02, a savings of approximately 20 percent over the worst-case CPI (equal to 5 cycles for all instructions, based the single-cycle datapath design constraint that all instructions run at the speed of the slowest).

4.4.4. Implementation of Finite-State Control

The FSC can be implemented in hardware using a read-only memory (ROM) or programmable logic array (PLA), as discussed in Section C.3 of the textbook. Combinatorial logic implements the transition function and a state register stores the current state of the machine (e.g., States 0 through 9 in the development of Section 4.4.2). The inputs are the IR opcode bits, and the outputs are the various datapath control signals (e.g., PCSrc, ALUop, etc.)

We next consider how the preceding function can be implemented using the technique of *microprogramming*.

4.5. Microprogrammed Control

Reading Assignments and Exercises

While the finite state control for the multicyle datapath was relatively easy to design, the graphical approach shown in Section 4.4 is limited to small control systems. We implemented only five MIPS instruction types, but the actual MIPS instruction set has over 100 different instructions. Recall that the FSC of Section 4.4 required 10 states for only five instruction types, and had CPI ranging from three to five. Now, observe that MIPS has not only 100 instructions,

but CPI ranging from one to 20 cycles. A control system for a realistic instruction set (even if it is RISC) would have hundreds or thousands of states, which could not be represented conveniently using the graphical technique of Section 4.4.

However, it is possible to develop a convenient technique of control system design and programming by using abstractions from programming language practice. This technique, called *microprogramming*, helps make control design more tractable and also helps improve correctness if good software engineering practice is followed. By using very low-level instructions (called *microinstructions*) that set the value of datapath control signals, one can write *microprograms* that implement a processor's control system(s). To do this, one specifies:

- *Microinstruction Format* that formalizes the structure and content of the microinstruction fields and functionality;
- *Sequencing Mechanism*, which determines whether the next instruction, or one indicated by a branch control structure, will be executed; and
- *Exception Handling* that determines what actions control should take when an error occurs (e.g., arithmetic overflow).

We consider these issues, as follows.

4.5.1. Microinstruction Format

A microinstruction is an abstraction of low-level control that is used to program control logic hardware. The microinstruction format should be simple, and should discourage or prohibit inconsistency. (An inconsistent microinstruction requires a given control signal to be set to two different values simultaneously, which is physically impossible.)

The implementation of each microinstruction should, therefore, make each field specify a set of nonoverlapping values. Signals that are never asserted concurrently can thus share the same field. Table 4.5 illustrates how this is realized in MIPS, using seven fields. The first six fields control the datapath, while the last field controls the microinstruction sequencing (deciding which microinstruction will be executed next).

Table 4.5. MIPS microinstruction format [MK98].

Field Name	Field Function
ALU control	Specify the operation performed by the ALU during this clock cycle, the result written to ALUout.
SRC1	Source for the first ALU operand
SRC2	Source for the second ALU operand
Register control	Specify read or write for Register File, as well as the source of a value to be written to the register file if write is enabled.
Memory	Specify read or write, and the source for a write. For a read, specify the destination register.
PCWrite control	Specify how the PC is to be written (e.g., PC+4, BTA, or JTA)
Sequencing	Specify how to choose the next microinstruction for execution

In hardware, microinstructions are usually stored in a ROM or PLA (per descriptions in Appendices B and C of the textbook). The microinstructions are usually referenced by sequential addresses to simplify sequencing. The sequencing process can have one of the following three modes:

1. *Incrementation*, by which the address of the current microinstruction is incremented to obtain the address of the next microinstruction. This is indicated by the value *Seq* in the *Sequencing* field of Table 4.5.
2. *Branching*, to the microinstruction that initiates execution of the next MIPS instruction. This is implemented by the value *Fetch* in the *Sequencing* field.
3. *Control-directed choice*, where the next microinstruction is chosen based on control input. We call this operation a *dispatch*. This is implemented by one or more address tables (similar to a jump table) called *dispatch tables*. The hardware implementation of dispatch tables is discussed in Section C.5 (Appendix C) of the textbook.

In the current subset of MIPS whose multicycle datapath we have been implementing, we need two dispatch tables, one each for State 1 and State 2. The use of a dispatch table numbered *i* is indicated in the microinstruction by putting *Dispatch i* in the *Sequencing* field.

Table 4.6 summarizes the allowable values for each field of the microinstruction and the effect of each value.

Table 4.6. MIPS microinstruction field values and functionality [MK98].

Field Name	Values for Field	Field Functionality
Label	Any string	Labels control sequencing, per p. 403 of the textbook
ALU control	Add Subt Func code	ALU performs addition operation ALU performs subtraction operation Instruction's funct field determines ALU operation
SRC1	PC A	The PC is the first ALU input Buffer register A is the first ALU input
SRC2	B 4 Extend Extshft	Buffer register B is the second ALU input The constant 4 is the second ALU input (for PC+4) Output of sign extension module is second ALU input Sign-extended output of two-bit shifter is second ALU input
Register Control	Read Write ALU Write MDR	Read two registers using rs and rt fields of the current instruction, putting data into buffers A and B Write to the register file using the rd field of the instruction register as the register number and the contents of ALUout as the data Write to the register file using the rd field of the instruction register as the register number and the contents of the MDR as the data
Memory	Read PC Read ALU	Read memory using the PC as the memory address, writing the result into the IR and MDR [implements instruction fetch] Read memory using ALUout as the address, write the result into MDR

	Write ALU	Write to memory using the ALUout contents as the address, writing to memory the data contained in buffer register B
PCWrite control	ALU	Write the output of the ALU into the PC register
	ALUout-cond	If the ALU's Zero output is high, write the contents of ALUout into the PC register
	Jump address	Write the PC with the jump address from the instruction
Sequencing	Seq	Choose the next microinstruction sequentially
	Fetch	Got to the first microinstruction to begin a new MIPS instruction
	Dispatch i	Dispatch using the ROM specified by i (where i = 1 or 2)

In practice, the microinstructions are input to a *microassembler*, which checks for inconsistencies. Detected inconsistencies are flagged and must be corrected prior to hardware implementation.

4.5.2. Microprogramming the Datapath Control

In this section, we use the fetch-decode-execute sequence that we developed for the multicycle datapath to design the microprogrammed control. First, we observe that sometimes an instruction might have a blank field. This is permitted when:

- A field that controls a functional unit (e.g., ALU, register file, memory) or causes state information to be written (e.g., *ALU dest* field), when blank, implies that no control signals should be asserted.
- A field that *only* specifies control of an input multiplexer for a functional unit, when left blank, implies that the datapath does not care about what value the output of the mux has.

We can now create the microprogram in stepwise fashion.

4.5.2.1. Instruction Fetch and Decode, Data Fetch. Each instruction execution first fetches the instruction, decodes it, and computes both the sequential PC and branch target PC (if applicable). The two microinstructions are given by:

Label	ALU control	SRC1	SRC2	Register control	Memory	PCWrite	Sequencing
Fetch	Add	PC	4	---	Read PC	ALU	Seq
---	Add	PC	Extshft	Read	---	---	Dispatch 1

where "---" denotes a blank field. In the first microinstruction,

- ALU control, SRC1, and SRC2 are set to compute PC+4, which is written to ALUout. The memory field reads the instruction at address equal to PC, and stores the instruction in the IR. The PCWrite control causes the ALU output (PC + 4) to be written into the PC, while the Sequencing field tells control to go to the next microinstruction.
- The label field (value = *fetch*) will be used to transfer control in the next Sequencing field when execution of the next instruction begins.

In the second microinstruction, we have the following actions:

- ALU control, SRC1, and SRC2 are set to store the PC plus the sign-extended, shifted IR[15:0] into ALUout. Register control causes data referenced by the *rs* and *rt* fields to be placed in ALU input registers A and B. output (PC + 4) to be written into the PC, while the Sequencing field tells control to go to dispatch table 1 for the next microinstruction address.

4.5.2.2. Dispatch Tables. Patterson and Hennessey consider the dispatch table as a *case* statement that uses the *opcode* field and dispatch table *i* to select one of N_i different labels. For in Dispatch Table #1 ($i = 1$, $N_i = 4$) we have label *Mem1* for memory reference instructions, *Rformat1* for arithmetic and logical instructions, *Beq1* for conditional branches, and *Jump1* for unconditional branches. Each of these labels points to a different microinstruction sequence that can be thought of as a kind of subprogram. Each microcode sequence can be thought of as comprising a small utility that implements the desired capability of specifying hardware control signals.

4.5.2.3. Memory Reference Instructions. Three microinstructions suffice to implement memory access in terms of a MIPS load instruction: (1) memory address computation, (2) memory read, and (3) register file write, as follows:

Label	ALU control	SRC1	SRC2	Register control	Memory	PCWrite	Sequencing
Mem1	Add	A	Extend	---	---	---	Dispatch 2
LW2	---	---	---	---	Read ALU	---	Seq
---	---	---	---	Write MDR	---	---	Fetch

The details of each microinstruction are given on pp. 405-406 of the textbook.

4.5.2.4. R-format Execution. R-format instruction execution requires two microinstructions: (1) ALU operation, labelled *Rformat1* for dispatching; and (2) write to register file, as follows:

Label	ALU control	SRC1	SRC2	Register control	Memory	PCWrite	Sequencing
Rformat1	Func code	A	B	---	---	---	Seq
---	---	---	---	Write ALU	---	---	Fetch

The details of each microinstruction are given on p. 406 of the textbook.

4.5.2.5. Branch and Jump Execution. Since we assume that the preceding microinstruction computed the BTA, the microprogram for a conditional branch requires only the following microinstruction:

Label	ALU control	SRC1	SRC2	Register control	Memory	PCWrite	Sequencing
Beq1	Subt	A	B	---	---	ALUout-cond	Fetch

Similarly, only one microinstruction is required to implement a Jump instruction:

Label	ALU control	SRC1	SRC2	Register control	Memory	PCWrite	Sequencing
Jump1	---	---	---	---	---	Jump address	Fetch

Implementational details are given on p. 407 of the textbook.

The composite microprogram is therefore given by the following ten instructions:

Label	ALU control	SRC1	SRC2	Register control	Memory	PCWrite	Sequencing
Fetch	Add	PC	4	---	Read PC	ALU	Seq
---	Add	PC	Extshft	Read	---	---	Dispatch 1
Mem1	Add	A	Extend	---	---	---	Dispatch 2
LW2	---	---	---	---	Read ALU	---	Seq
---	---	---	---	Write MDR	---	---	Fetch
SW2	---	---	---	---	Write ALU	---	Fetch
Rformat1	Func code	A	B	---	---	---	Seq
---	---	---	---	Write ALU	---	---	Fetch
Beq1	Subt	A	B	---	---	ALUout-cond	Fetch
Jump1	---	---	---	---	---	Jump address	Fetch

Here, we have added the *SW2* microinstruction to illustrate the final step of the store instruction.

Observe that these ten instructions correspond directly to the ten states of the finite-state control developed in Section 4.4. In more complex machines, microprogram control can comprise tens or hundreds of thousands of microinstructions, with special-purpose registers used to store intermediate data.

4.5.3. Implementing a Microprogram

It is useful to think of a microprogram as a textual representation of a finite-state machine. Thus, a microprogram could be implemented similar to the FSC that we developed in Section 4.4, using a PLA to encode the sequencing function and main control. However, it is often useful to store the control function in a ROM, then implementing the sequencing function in some other way. Typically, the sequencer uses an incrementer to choose the next control instruction. Here, the microcode storage determines the values of datapath control lines and the technique of selecting the next state. Address select logic contains dispatch tables (in ROMs or PLAs) and determines the next microinstruction to execute, albeit under control of the address select outputs.

This technique is preferred, since it substitutes a simple counter for more complex address control logic, which is especially efficient if the microinstructions have little branching. Using a ROM, the microcode can be stored in its own memory and is addressed by the microprogram counter, similar to regular program instructions being addressed by an instruction sequencer.

It is interesting to note that this is how microprogramming actually got started, by making the ROM and counter very fast. This represented a great advance over using slower main memory for microprogram storage. Today, however, advances in cache technology make a separate microprogram memory an obsolete development, as it is easier to store the microprogram in main memory and page the parts of it that are needed into cache, where retrieval is fast and uses no extra hardware.

4.5.4. Exception Handling

If control design was not hard enough, we also have to deal with the very difficult problem of implementing exceptions and interrupts, which are defined as follows:

- An *exception* is an anomalous event arising from within the processor, such as arithmetic overflow.
- An *interrupt* is an event that causes an unexpected change in control flow. Interrupts are assumed to originate outside the processor, for example, an I/O request.

In this discussion, we follow Patterson and Hennessey's convention, for simplicity: An interrupt is an externally caused event, and an exception one of all other events that cause unexpected control flow in a program. An interesting comparison of this terminology for different processors and manufacturers is given on pp. 410-411 of the textbook.

In this section, we discuss control design required to handle two types of exceptions: (1) an undefined instruction, and (2) arithmetic overflow. These exceptions are germane to the small language (five instructions) whose implementation we have been exploring thus far.

4.5.4.1. Basic Exception Handling Mechanism. After an exception is detected, the processor's control circuitry must be able to (s) save the address in the exception counter (EPC) of the instruction that caused the exception, then (2) transfer control to the operating system (OS) at a prespecified address. The second step typically invokes an *exception handler*, which is a routine that either (a) helps the program recover from the exception or (b) issues an error message, then attempts to terminate the program in an orderly fashion.

If program execution is to continue after the exception is detected and handled, then the EPC register helps determine where to restart the program. For example, the exception-causing instruction can be repeated byt in a way that does not cause an exception. Alternatively, the next instruction can be executed (in MIPS, this instruction's address is $\$epc + 4$).

For the OS to handle the exception, one of two techniques are employed. First, the machine can have *Cause* and *EPC* registers, which contain codes that respectively represent the cause of the exception and the address of the exception-causing instruction. A second method uses *vectored interrupts*, where the address to which control is transferred following the exception is determined by the cause of the exception. If vectored interrupts are not employed, control is transferred to one address only, regardless of cause. Then, the cause is used to determine what action the exception handling routine should take.

4.5.4.2. Hardware Support. MIPS uses the latter method, called *non-vectored exceptions*. To support this capability in the datapath that we have been developing in this section, we need to add the following two registers:

- *EPC*: 32-bit register holds the address of the exception-causing instruction, and
- *Cause*: 32-bit register contains a binary code that describes the cause or type of exception.

Two additional control signals are needed: $EPCWrite$ and $CauseWrite$, which write the appropriate information to the EPC and $Cause$ registers. Also required in this particular implementation is a 1-bit signal to set the LSB of $Cause$ to be 0 for an undefined instruction, or 1 for arithmetic overflow. Of further use is an address A_E that points to the exception handling routine to which control is transferred. In MIPS, we assume that $A_E = C0000000_{16}$.

In the previous datapath developed through Section 4.4, the PC input is taken from a four-way mux that has three inputs defined, which are: PC+4, BTA, and JTA. Without adding control lines, we can add a fourth possible input to the PC, namely A_E , which is written to the PC by setting $PCSource = 11_2$.

Unfortunately, we cannot simply write the PC into the EPC, since the PC is incremented at instruction fetch (Step 1 of the multicycle datapath) instead of instruction execution (Step 3) when the exception actually occurs. Thus, when an exception is detected, the ALU must subtract 4 from the PC and the ALUout register contents must be written to the EPC. It is fortunate that this requires no additional control signals or lines in this particular datapath design, since 4 is already a selectable ALU input (used for incrementing the PC during instruction fetch, and is selected via $ALUSrcB$ control signal).

Hardware support for the datapath modifications needed to implement exception handling in the simple case illustrated in this section is shown in Figure 4.23. In the finite-state diagrams of Figure 4.24 and 4.25, we see that each of the preceding two types of exceptions can be handled using one state each. For each exception type, the state actions are: (1) set the $Cause$ register contents to reflect exception type, (2) compute and save PC-4 into the EPC to make available the return address, and (3) write the address A_E to the PC so control can be transferred to the exception handler. To update the finite-state control (FSC) diagram of Figure 4.22, we need to add the two states shown in Figure 4.24.

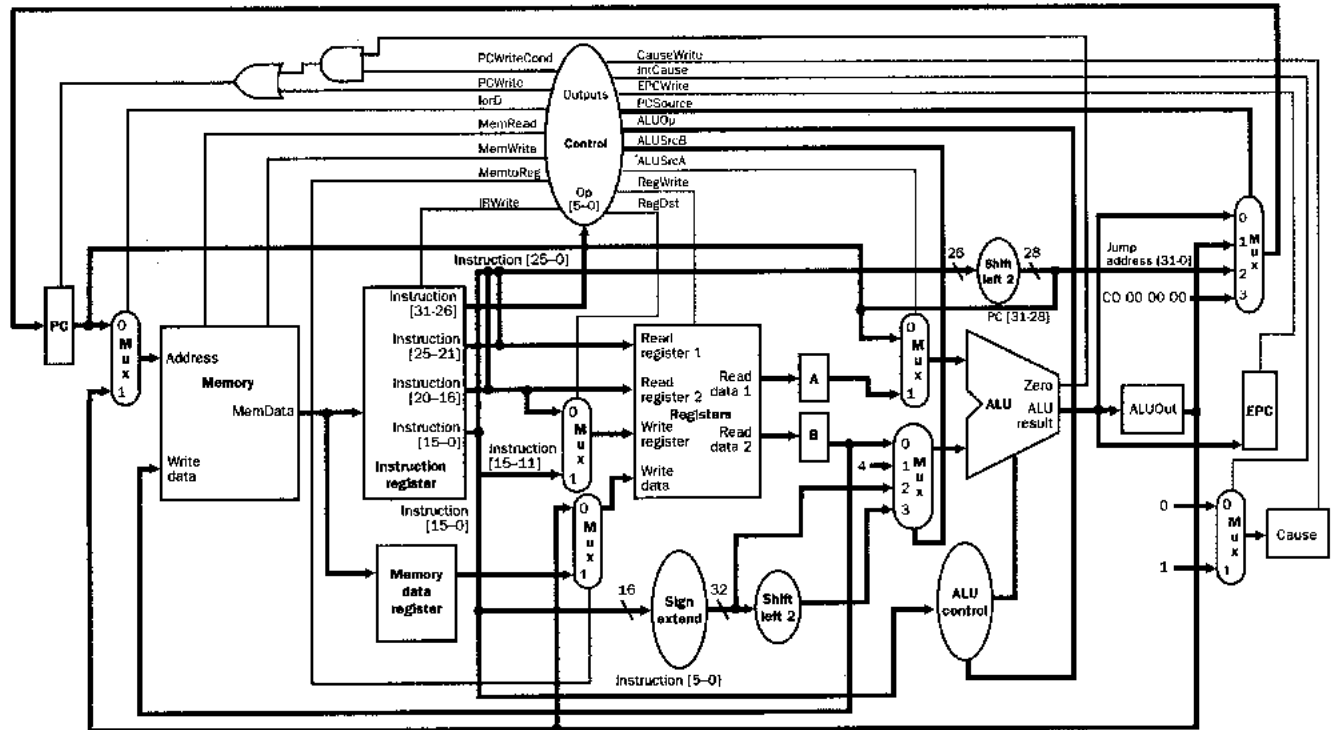

Figure 4.23. Representation of the composite datapath architecture and control for the MIPS multicycle datapath, with provision for exception handling [MK98].

Thus far, we have discussed exceptions and how to handle them, and have illustrated the requirements of hardware support in the multicycle datapath developed in this section. In the following section, we complete this discussion with an overview of the necessary steps in exception detection.

4.5.4.3. Exception Detection. Each of the two possible exception types in our example MIPS multicycle datapath is detected differently, as follows:

- *Undefined Instruction:* Finite state control must be modified to define the next-state value as 10 (the eleventh state of our control FSM) for all operation types other than the five that are allowed (i.e., lw, sw, beg, jump, and R-format). In the FSM diagram of Figure 4.25, this is shown as *other*.
- *Arithmetic Overflow:* Recall that an ALU can be designed to include overflow detection logic with a signal output from the ALU called *overflow*, which is asserted if overflow is detected. This is used to specify the next state for State 7 in the FSM of Figure 4.25.

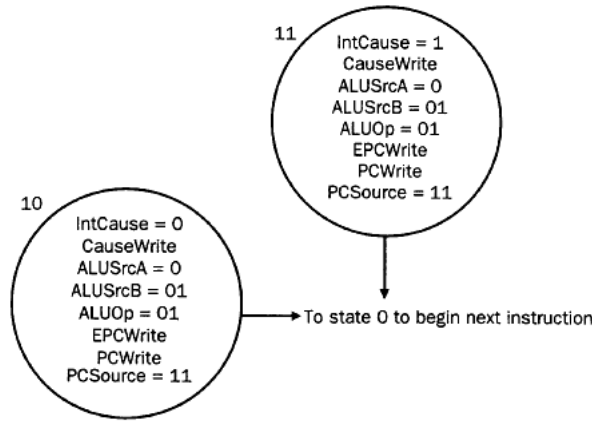

Figure 4.24. Representation of the finite-state models for two types of exceptions in the MIPS multicyle datapath [MK98].

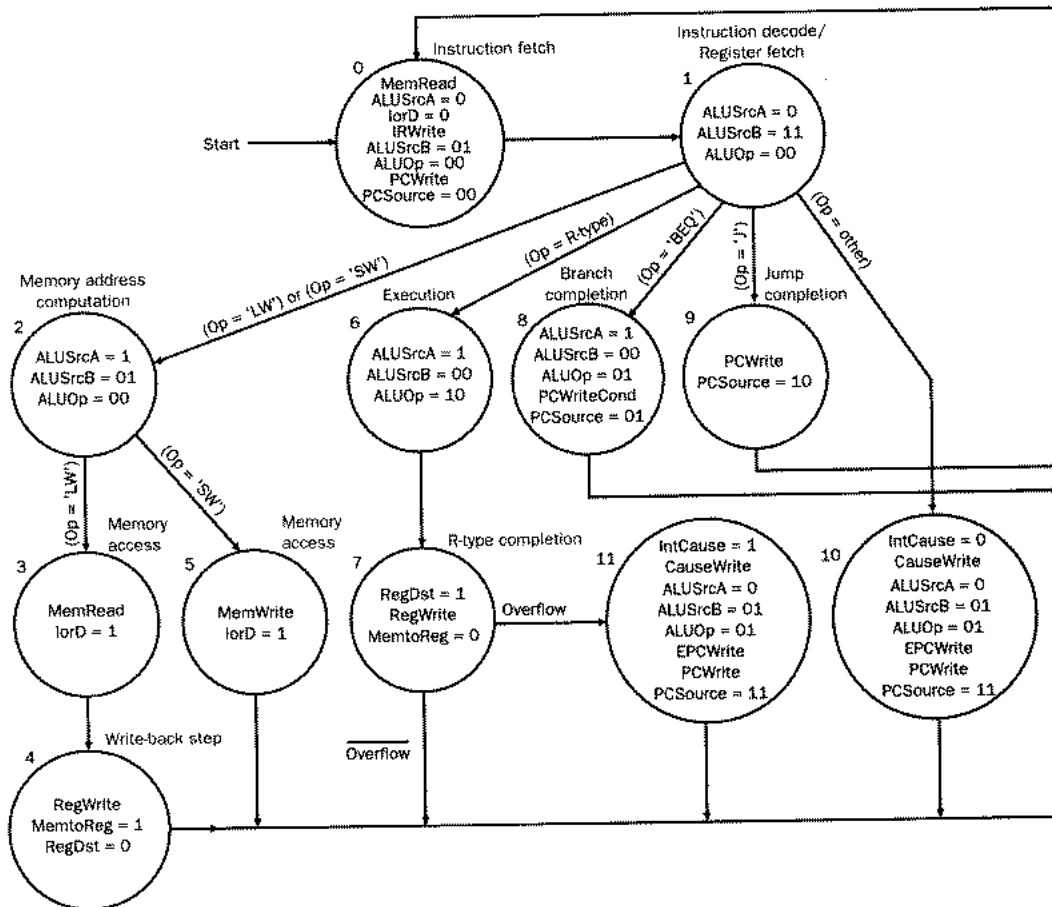

Figure 4.25. Representation of the composite finite-state control for the MIPS multicyle datapath, including exception handling [MK98].

As a result of these modifications, Figure 4.25 represents a complete specification of control for our five-instruction MIPS datapath, including mechanisms to handle two types of exceptions. Our design goal remains keeping the control logic small, fast, and accurate.

Unfortunately, the FSC in Figure 4.25 has some flaws. For example, the overflow detection circuitry does not cause the ALU operation to be rolled back or restarted. Rather, the ALU result appears in the ALUout register whether or not there is an exception. This contradicts this MIPS ISA, which specifies that an instruction should have no effect on the datapath if it causes an exception. In practice, certain types of exceptions require process rollback and this greatly increases the control system complexity, also decreasing performance.

Reading Assignment: Study carefully Section 5.7 of the textbook (pp. 416-419) on the Pentium Pro exception handling mechanism.

4.5.3. Summary

We have developed a multicyle datapath and focused on (a) performance analysis and (b) control system design and implementation. Microprogramming was seen to be an especially useful way to design control systems. Unfortunately, there are two assumptions about microprogramming that are potentially dangerous to computer designers or engineers, which are discussed as follows.

First, it has long been assumed that microcode is a faster way to implement an instruction than a sequence of simpler instructions. This is an instance of a conflict in design philosophy that is rooted in CISC versus RISC tradeoffs. In the past (CISC practice), microcode was stored in a very fast local memory, so microcode sequences could be fetched very quickly. This made it look as though microcode was executing very fast, when in fact it used the same datapath as higher-level instructions - only the microprogram memory throughput was faster. Today, with fast caches widely available, microcode performance is about the same as that of the CPU executing simple instructions. The one exception is an architecture with few general-purpose registers (CISC-like), in which microcode might not be swapped in and out of the register file very efficiently.

Another disadvantage of using microcode-intensive execution is that the microcode (and therefore the instruction set) must be selected and settled upon before a new architecture is made available. This code cannot be changed until a new model is released. In contrast, software-based approaches to control system design are much more flexible, since the (few, simple) instructions reside in fast memory (e.g., cache) and can be changed at will. At the very worst, a new compiler or assembler revision might be required, but that is common practice nowadays, and far less expensive than hardware revision.

The second misleading assumption about microcode is that if you have some extra room in the control store after a processor control system is designed, support for new instructions can be added for free. This is not true, because of the typical requirement of *upward compatibility*. That is, any future models of the given architecture must include the "free" instructions that were added after initial processor design, regardless of whether or not the control storage space might be at a premium in future revisions of the architecture.

This concludes our discussion of datapaths, processors, control, and exceptions. We next concentrate on another method of increasing the performance of the multicycle datapath, called *pipelining*.

References

[Maf01] Mafla, E. *Course Notes, CDA3101*, at URL <http://www.cise.ufl.edu/~emaf1a/> (as-of 11 Apr 2001).

[MK98] Copyright 1998 Morgan Kaufmann Publishers, Inc. All Rights Reserved, per copyright notice request at http://www.mkp.com/books_catalog/cod2/cod2ecrt.htm (1998).

[Pat98] Patterson, D.A. and J.L. Hennesey. *Computer Organization and Design: The Hardware/Software Interface*, Second Edition, San Francisco, CA: Morgan Kaufman (1998).
