



US012349941B2

(12) **United States Patent**
Dayton et al.

(10) **Patent No.:** **US 12,349,941 B2**
(45) **Date of Patent:** **Jul. 8, 2025**

(54) **BONE POSITIONING AND CUTTING SYSTEM AND METHOD**

17/7052; A61B 17/6441; A61B 17/645;
A61B 17/6466; A61B 17/6491

(71) Applicant: **Treace Medical Concepts, Inc.**, Ponte Vedra, FL (US)

USPC 606/54-59, 90, 105
See application file for complete search history.

(72) Inventors: **Paul Dayton**, Ankeny, IA (US); **F. Barry Bays**, Collierville, TN (US)

(56) **References Cited**

U.S. PATENT DOCUMENTS

(73) Assignee: **Treace Medical Concepts, Inc.**, Ponte Vedra, FL (US)

3,664,022 A 5/1972 Small
4,069,824 A 1/1978 Weinstock

(Continued)

(*) Notice: Subject to any disclaimer, the term of this patent is extended or adjusted under 35 U.S.C. 154(b) by 0 days.

FOREIGN PATENT DOCUMENTS

(21) Appl. No.: **18/615,875**

AU 2009227957 B2 7/2014
CA 2491824 A1 9/2005

(Continued)

(22) Filed: **Mar. 25, 2024**

OTHER PUBLICATIONS

(65) **Prior Publication Data**

US 2024/0260995 A1 Aug. 8, 2024

“Accu-Cut Osteotomy Guide System,” BioPro, Brochure, Oct. 2018, 2 pages.

(Continued)

Related U.S. Application Data

(60) Continuation of application No. 17/503,730, filed on Oct. 18, 2021, now Pat. No. 11,937,849, which is a continuation of application No. 17/201,008, filed on Mar. 15, 2021, now Pat. No. 11,147,590, which is a continuation of application No. 16/730,424, filed on Dec. 30, 2019, now Pat. No. 10,945,764, which is a continuation of application No. 15/894,702, filed on (Continued)

Primary Examiner — Eduardo C Robert
Assistant Examiner — Christina Negrelli-rodriguez
(74) *Attorney, Agent, or Firm* — Fredrikson & Byron, P.A.

(57) **ABSTRACT**

A bone positioning device can include a fixation pin for attachment to a first bone and a fixation pin for attachment to a second bone. A first block having an aperture can be included for slidably receiving a fixation pin, and a second block having an aperture can be included for slidably receiving a fixation pin. A multi-axis joint can connect the first block and the second block, where the multi-axis joint allows the first second blocks to move with respect to each other about more than one axis.

(51) **Int. Cl.**
A61B 17/64 (2006.01)
A61B 17/15 (2006.01)
A61B 17/66 (2006.01)

(52) **U.S. Cl.**
CPC **A61B 17/6416** (2013.01); **A61B 17/151** (2013.01); **A61B 17/66** (2013.01)

(58) **Field of Classification Search**
CPC . A61B 17/64; A61B 17/6416; A61B 17/6425; A61B 17/6458; A61B 17/66; A61B

27 Claims, 11 Drawing Sheets

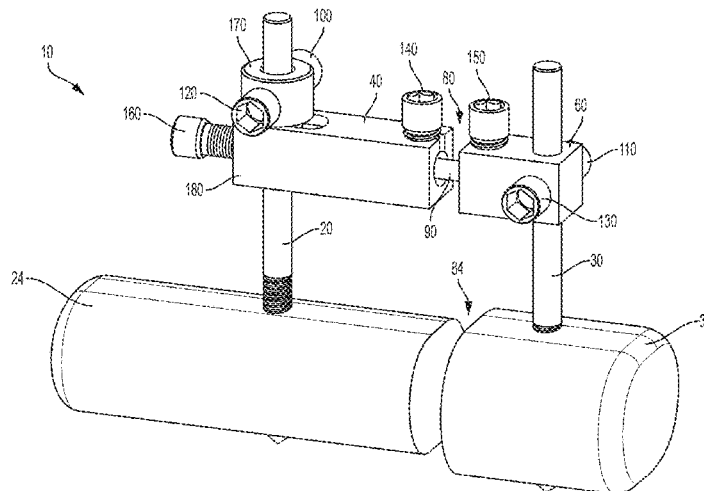

Related U.S. Application Data

Feb. 12, 2018, now Pat. No. 10,555,757, which is a division of application No. 14/799,981, filed on Jul. 15, 2015, now abandoned.

(60) Provisional application No. 62/024,546, filed on Jul. 15, 2014.

(56) **References Cited**

U.S. PATENT DOCUMENTS

4,159,716 A 7/1979 Borchers
 4,187,840 A 2/1980 Watanabe
 4,335,715 A 6/1982 Kirkley
 4,338,927 A 7/1982 Volkov et al.
 4,349,018 A 9/1982 Chambers
 4,364,381 A 12/1982 Sher et al.
 4,409,973 A 10/1983 Neufeld
 4,440,168 A 4/1984 Warren
 4,501,268 A 2/1985 Comparetto
 4,502,474 A 3/1985 Comparetto
 4,509,511 A 4/1985 Neufeld
 4,565,191 A 1/1986 Slocum
 4,570,624 A 2/1986 Wu
 4,627,425 A 12/1986 Reese
 4,628,919 A 12/1986 Clyburn
 4,632,102 A 12/1986 Comparetto
 4,664,102 A 5/1987 Comparetto
 4,708,133 A 11/1987 Comparetto
 4,736,737 A 4/1988 Fargie et al.
 4,750,481 A 6/1988 Reese
 4,754,746 A 7/1988 Cox
 4,757,810 A 7/1988 Reese
 4,895,141 A 1/1990 Koeneman et al.
 4,952,214 A 8/1990 Comparetto
 4,959,066 A 9/1990 Dunn et al.
 4,978,347 A 12/1990 Ilizarov
 4,988,349 A * 1/1991 Pennig A61B 17/66
 4,995,875 A 2/1991 Coes 606/57
 5,021,056 A 6/1991 Hofmann et al.
 5,035,698 A 7/1991 Comparetto
 5,042,983 A 8/1991 Rayhack
 5,049,149 A 9/1991 Schmidt
 5,053,039 A 10/1991 Hofmann et al.
 5,078,719 A 1/1992 Schreiber
 5,112,334 A 5/1992 Alchermes et al.
 5,147,364 A 9/1992 Comparetto
 5,176,685 A 1/1993 Rayhack
 5,207,676 A 5/1993 Canadell et al.
 5,246,444 A 9/1993 Schreiber
 5,254,119 A 10/1993 Schreiber
 5,312,412 A 5/1994 Whipple
 5,358,504 A 10/1994 Paley et al.
 5,364,402 A 11/1994 Mumme et al.
 5,374,271 A 12/1994 Hwang
 5,413,579 A 5/1995 Du Toit
 5,417,694 A 5/1995 Marik et al.
 5,449,360 A 9/1995 Schreiber
 5,470,335 A 11/1995 Du Toit
 5,490,854 A 2/1996 Fisher et al.
 5,529,075 A 6/1996 Clark
 5,540,695 A 7/1996 Levy
 5,578,038 A 11/1996 Slocum
 5,586,564 A 12/1996 Barrett et al.
 5,601,565 A 2/1997 Huebner
 5,613,969 A 3/1997 Jenkins, Jr.
 5,620,442 A 4/1997 Bailey et al.
 5,620,448 A 4/1997 Puddu
 5,643,270 A 7/1997 Combs
 5,667,510 A 9/1997 Combs
 H1706 H 1/1998 Mason
 5,722,978 A 3/1998 Jenkins
 5,749,875 A 5/1998 Puddu
 5,779,709 A 7/1998 Harris et al.
 5,788,695 A 8/1998 Richardson

5,803,924 A 9/1998 Oni et al.
 5,810,822 A 9/1998 Mortier
 5,843,085 A 12/1998 Graser
 5,893,553 A 4/1999 Pinkous
 5,911,724 A 6/1999 Wehrli
 5,935,128 A 8/1999 Carter et al.
 5,941,877 A 8/1999 Viegas et al.
 5,951,556 A 9/1999 Faccioli et al.
 5,980,526 A 11/1999 Johnson et al.
 5,984,931 A 11/1999 Greenfield
 6,007,535 A 12/1999 Rayhack et al.
 6,027,504 A 2/2000 McGuire
 6,030,391 A 2/2000 Brainard et al.
 6,162,223 A 12/2000 Orsak et al.
 6,171,309 B1 1/2001 Huebner
 6,203,545 B1 3/2001 Stoffella
 6,248,109 B1 6/2001 Stoffella
 6,391,031 B1 5/2002 Toomey
 6,478,799 B1 11/2002 Williamson
 6,511,481 B2 1/2003 von Hoffmann et al.
 6,547,793 B1 4/2003 McGuire
 6,676,662 B1 1/2004 Bagga et al.
 6,719,773 B1 4/2004 Boucher et al.
 6,743,233 B1 6/2004 Baldwin et al.
 6,755,838 B2 6/2004 Trnka
 6,796,986 B2 9/2004 Duffner
 6,859,661 B2 2/2005 Tuke
 7,018,383 B2 3/2006 McGuire
 7,033,361 B2 4/2006 Collazo
 7,097,647 B2 8/2006 Segler et al.
 7,112,204 B2 9/2006 Justin et al.
 7,153,310 B2 12/2006 Ralph et al.
 7,182,766 B1 2/2007 Mogul
 7,241,298 B2 7/2007 Nemeec et al.
 7,282,054 B2 10/2007 Steffensmeier et al.
 7,377,924 B2 5/2008 Raistrick et al.
 7,465,303 B2 12/2008 Riccione et al.
 7,540,874 B2 6/2009 Trumble et al.
 7,572,258 B2 8/2009 Stiernborg
 7,641,660 B2 1/2010 Lakin et al.
 D610,257 S 2/2010 Horton
 7,686,811 B2 3/2010 Byrd et al.
 7,691,108 B2 4/2010 Lavallee
 7,763,026 B2 7/2010 Egger et al.
 D629,900 S 12/2010 Fisher
 7,967,823 B2 6/2011 Ammann et al.
 7,972,338 B2 7/2011 O'Brien
 D646,389 S 10/2011 Claypool et al.
 8,057,478 B2 11/2011 Kuczynski et al.
 8,062,301 B2 11/2011 Ammann et al.
 D651,315 S 12/2011 Bertoni et al.
 D651,316 S 12/2011 May et al.
 8,080,010 B2 12/2011 Schulz et al.
 8,080,045 B2 12/2011 Wotton, III
 8,083,746 B2 12/2011 Novak
 8,123,753 B2 2/2012 Poncet
 8,137,406 B2 3/2012 Novak et al.
 8,147,530 B2 4/2012 Strnad et al.
 8,167,918 B2 5/2012 Strnad et al.
 8,172,848 B2 5/2012 Tomko et al.
 8,192,441 B2 6/2012 Collazo
 8,197,487 B2 6/2012 Poncet et al.
 8,231,623 B1 7/2012 Jordan
 8,231,663 B2 7/2012 Kay et al.
 8,236,000 B2 8/2012 Ammann et al.
 8,246,561 B1 8/2012 Agee et al.
 D666,721 S 9/2012 Wright et al.
 8,262,664 B2 9/2012 Justin et al.
 8,277,459 B2 10/2012 Sand et al.
 8,282,644 B2 10/2012 Edwards
 8,282,645 B2 10/2012 Lawrence et al.
 8,292,966 B2 10/2012 Morton
 8,303,596 B2 11/2012 Plassky et al.
 8,313,492 B2 11/2012 Wong et al.
 8,323,289 B2 12/2012 Re
 8,337,503 B2 12/2012 Lian
 8,343,159 B2 1/2013 Bennett
 8,377,105 B2 2/2013 Buescher
 D679,395 S 4/2013 Wright et al.

(56)		References Cited						
		U.S. PATENT DOCUMENTS						
8,409,209	B2	4/2013	Ammann et al.	2004/0097946	A1	5/2004	Dietzel et al.	
8,435,246	B2	5/2013	Fisher et al.	2004/0138669	A1	7/2004	Horn	
8,475,462	B2	7/2013	Thomas et al.	2005/0004676	A1	1/2005	Schon et al.	
8,496,662	B2	7/2013	Novak et al.	2005/0059978	A1	3/2005	Sherry et al.	
8,523,870	B2	9/2013	Green et al.	2005/0070909	A1	3/2005	Egger et al.	
8,529,571	B2	9/2013	Horan et al.	2005/0075641	A1	4/2005	Singhatat et al.	
8,540,777	B2	9/2013	Ammann et al.	2005/0101961	A1	5/2005	Huebner et al.	
8,545,508	B2	10/2013	Collazo	2005/0149042	A1	7/2005	Metzger	
D694,884	S	12/2013	Mooradian et al.	2005/0228389	A1	10/2005	Stiernborg	
D695,402	S	12/2013	Dacosta et al.	2005/0251147	A1	11/2005	Novak	
8,652,142	B2	2/2014	Geissler	2005/0267482	A1	12/2005	Hyde, Jr.	
8,657,820	B2	2/2014	Kubiak et al.	2005/0273112	A1	12/2005	McNamara	
D701,303	S	3/2014	Cook	2006/0036257	A1	2/2006	Steffensmeier	
8,672,945	B2	3/2014	Lavallee et al.	2006/0129163	A1	6/2006	McGuire	
8,696,716	B2	4/2014	Kartalian et al.	2006/0206044	A1	9/2006	Simon	
8,702,715	B2	4/2014	Ammann et al.	2006/0217733	A1	9/2006	Plassky et al.	
D705,929	S	5/2014	Frey	2006/0229621	A1	10/2006	Cadmus	
8,715,363	B2	5/2014	Ratron et al.	2006/0241607	A1	10/2006	Myerson et al.	
8,728,084	B2	5/2014	Berelsman et al.	2006/0241608	A1	10/2006	Myerson et al.	
8,758,354	B2	6/2014	Habegger et al.	2006/0264961	A1	11/2006	Murray-Brown	
8,764,760	B2	7/2014	Metzger et al.	2007/0010818	A1	1/2007	Stone et al.	
8,764,763	B2	7/2014	Wong et al.	2007/0123857	A1	5/2007	Deffenbaugh et al.	
8,771,279	B2	7/2014	Philippon et al.	2007/0233138	A1	10/2007	Figueroa et al.	
8,777,948	B2	7/2014	Bernsteiner	2007/0265634	A1	11/2007	Weinstein	
8,784,427	B2	7/2014	Fallin et al.	2007/0276383	A1	11/2007	Rayhack	
8,784,457	B2	7/2014	Graham	2008/0009863	A1	1/2008	Bond et al.	
8,795,286	B2	8/2014	Sand et al.	2008/0015603	A1	1/2008	Collazo	
8,801,727	B2	8/2014	Chan et al.	2008/0039850	A1	2/2008	Rowley et al.	
8,808,303	B2	8/2014	Stemniski et al.	2008/0091197	A1	4/2008	Coughlin	
8,828,012	B2	9/2014	May et al.	2008/0140081	A1	6/2008	Heavener et al.	
8,858,602	B2	10/2014	Weiner et al.	2008/0147073	A1	6/2008	Ammann et al.	
8,882,778	B2	11/2014	Ranft	2008/0172054	A1	7/2008	Claypool et al.	
8,882,816	B2	11/2014	Kartalian et al.	2008/0195215	A1	8/2008	Morton	
8,888,785	B2	11/2014	Ammann et al.	2008/0208252	A1	8/2008	Holmes	
D720,456	S	12/2014	Dacosta et al.	2008/0262500	A1	10/2008	Collazo	
8,900,247	B2	12/2014	Tseng et al.	2008/0269908	A1	10/2008	Warburton	
8,906,026	B2	12/2014	Ammann et al.	2008/0288004	A1	11/2008	Schendel	
8,945,132	B2	2/2015	Plassy et al.	2009/0036893	A1	2/2009	Kartalian et al.	
8,998,903	B2	4/2015	Price et al.	2009/0036931	A1	2/2009	Pech et al.	
8,998,904	B2	4/2015	Zeetser et al.	2009/0054899	A1	2/2009	Ammann et al.	
9,011,507	B2	4/2015	Schelling	2009/0093849	A1	4/2009	Grabowski	
9,023,052	B2	5/2015	Lietz et al.	2009/0105767	A1	4/2009	Reiley	
9,044,250	B2	6/2015	Olsen et al.	2009/0112212	A1	4/2009	Murray et al.	
9,060,822	B2	6/2015	Lewis et al.	2009/0118733	A1*	5/2009	Orsak	A61B 17/6475 606/329
9,089,376	B2	7/2015	Medoff et al.	2009/0198244	A1	8/2009	Leibel	
9,101,421	B2	8/2015	Blacklidge	2009/0198279	A1*	8/2009	Zhang	A61B 17/7023 606/301
9,107,715	B2	8/2015	Blitz et al.	2009/0222047	A1	9/2009	Graham	
9,113,920	B2	8/2015	Ammann et al.	2009/0254092	A1	10/2009	Albiol Llorach	
D740,424	S	10/2015	Dacosta et al.	2009/0254126	A1	10/2009	Orbay et al.	
D765,844	S	9/2016	DaCosta	2009/0287309	A1	11/2009	Walch et al.	
D766,434	S	9/2016	DaCosta	2010/0069910	A1	3/2010	Hasselman	
D766,437	S	9/2016	DaCosta	2010/0121334	A1	5/2010	Couture et al.	
D766,438	S	9/2016	DaCosta	2010/0130981	A1	5/2010	Richards	
D766,439	S	9/2016	DaCosta	2010/0152782	A1	6/2010	Stone et al.	
9,452,057	B2	9/2016	Dacosta et al.	2010/0168799	A1	7/2010	Schumer	
9,522,023	B2	11/2016	Haddad et al.	2010/0185245	A1	7/2010	Paul et al.	
9,750,538	B2	9/2017	Soffiatti et al.	2010/0249779	A1	9/2010	Hotchkiss et al.	
9,785,747	B2	10/2017	Geebelen	2010/0256687	A1	10/2010	Neufeld et al.	
9,980,760	B2	5/2018	Dacosta et al.	2010/0318088	A1	12/2010	Warne et al.	
10,028,750	B2	7/2018	Rose	2010/0324556	A1	12/2010	Tyber et al.	
10,064,631	B2	9/2018	Dacosta et al.	2011/0009865	A1	1/2011	Orfaly	
10,159,499	B2	12/2018	Dacosta et al.	2011/0093084	A1	4/2011	Morton	
10,292,713	B2	5/2019	Fallin et al.	2011/0118739	A1	5/2011	Tyber et al.	
10,327,829	B2	6/2019	Dacosta et al.	2011/0178524	A1	7/2011	Lawrence et al.	
10,376,268	B2	8/2019	Fallin et al.	2011/0245835	A1	10/2011	Dodds et al.	
10,470,779	B2	11/2019	Fallin et al.	2011/0264149	A1	10/2011	Pappalardo et al.	
10,779,867	B2	9/2020	Penzimer et al.	2011/0288550	A1	11/2011	Orbay et al.	
11,304,705	B2	4/2022	Fallin et al.	2011/0301648	A1	12/2011	Lofthouse et al.	
2002/0058944	A1	5/2002	Michelson	2012/0016426	A1	1/2012	Robinson	
2002/0099381	A1	7/2002	Maroney	2012/0065689	A1	3/2012	Prasad et al.	
2002/0107519	A1	8/2002	Dixon et al.	2012/0078258	A1	3/2012	Lo et al.	
2002/0165552	A1	11/2002	Duffner	2012/0123420	A1	5/2012	Honiball	
2002/0198531	A1	12/2002	Millard et al.	2012/0123484	A1	5/2012	Lietz et al.	
2004/0010259	A1	1/2004	Keller et al.	2012/0130376	A1	5/2012	Loring et al.	
2004/0039394	A1	2/2004	Conti et al.	2012/0130382	A1	5/2012	Iannotti et al.	
				2012/0130383	A1	5/2012	Budoff	
				2012/0184961	A1	7/2012	Johannaber	

(56)

References Cited

FOREIGN PATENT DOCUMENTS

JP	2006158972	A	6/2006
JP	4134243	B2	8/2008
JP	2008537498	A	9/2008
JP	4162380	B2	10/2008
JP	2011092405	A	5/2011
JP	2011523889	A	8/2011
JP	4796943	B2	10/2011
JP	5466647	B2	4/2014
JP	2014511207	A	5/2014
JP	2014521384	A	8/2014
JP	5628875	B2	11/2014
KR	100904142	B1	6/2009
MD	756	Z	11/2014
RU	2098036	C1	12/1997
RU	2195892	C2	1/2003
RU	2320287	C1	3/2008
RU	2321366	C2	4/2008
RU	2321369	C1	4/2008
RU	2346663	C2	2/2009
RU	2412662	C1	2/2011
SU	1333328	A2	8/1987
WO	0166022	A1	9/2001
WO	03075775	A1	9/2003
WO	2004089227	A2	10/2004
WO	2008051064	A1	5/2008
WO	2009029798	A1	3/2009
WO	2009032101	A2	3/2009
WO	2011037885	A1	3/2011
WO	2012029008	A1	3/2012
WO	2013090392	A1	6/2013
WO	2013134387	A1	9/2013
WO	2013169475	A1	11/2013
WO	2014020561	A1	2/2014
WO	2014022055	A1	2/2014
WO	2014035991	A1	3/2014
WO	2014085882	A1	6/2014
WO	2014147099	A1	9/2014
WO	2014152219	A2	9/2014
WO	2014152535	A1	9/2014
WO	2014177783	A1	11/2014
WO	2014200017	A1	12/2014
WO	2015094409	A1	6/2015
WO	2015105880	A1	7/2015
WO	2015127515	A2	9/2015
WO	2016134160	A1	8/2016

OTHER PUBLICATIONS

"Acumed Osteotomiesystem Operationstechnik," Acumed, 2014, 19 pages (including 3 pages English translation).

Albano et al., "Biomechanical Study of Transcortical or Transtrabecular Bone Fixation of Patellar Tendon Graft with Bioabsorbable Pins in ACL Reconstruction in Sheep," *Revista Brasileira de Ortopedia (Rev Bras Ortop.)* vol. 47, No. 1, 2012, pp. 43-49.

Alvine et al., "Peg and Dowel Fusion of the Proximal Interphalangeal Joint," *Foot & Ankle*, vol. 1, No. 2, 1980, pp. 90-94.

Anderson et al., "Uncemented STAR Total Ankle Prostheses," *The Journal of Bone and Joint Surgery*, vol. 86(1, Suppl 2), Sep. 2004, pp. 103-111, (Abstract Only).

Bednarz et al., "Modified Lapidus Procedure for the Treatment of Hypermobile Hallux Valgus," *Foot & Ankle International*, vol. 21, No. 10, Oct. 2000, pp. 816-821.

Blomer, "Knieendoprothetik—Herstellereische Probleme und technologische Entwicklungen," *Orthopade*, vol. 29, 2000, pp. 688-696, including English Abstract on p. 689.

Bouaicha et al., "Fixation of Maximal Shift Scarf Osteotomy with Inside-Out Plating: Technique Tip," *Foot & Ankle International*, vol. 32, No. 5, May 2011, pp. 567-569.

Carr et al., "Correctional Osteotomy for Metatarsus Primus Varus and Hallux Valgus," *The Journal of Bone and Joint Surgery*, vol. 50-A, No. 7, Oct. 1968, pp. 1353-1367.

Coetzee et al., "The Lapidus Procedure: A Prospective Cohort Outcome Study," *Foot & Ankle International*, vol. 25, No. 8, Aug. 2004, pp. 526-531.

Dayton et al., "Is Our Current Paradigm for Evaluation and Management of the Bunion Deformity Flawed? A Discussion of Procedure Philosophy Relative to Anatomy," *The Journal of Foot and Ankle Surgery*, vol. 54, 2015, pp. 102-111.

Dayton et al., "Observed Changes in Radiographic Measurements of the First Ray after Frontal and Transverse Plane Rotation of the Hallux: Does the Hallux Drive the Metatarsal in a Bunion Deformity?," *The Journal of Foot and Ankle Surgery*, vol. 53, 2014, pp. 584-587.

Dayton et al., "Relationship of Frontal Plane Rotation of First Metatarsal to Proximal Articular Set Angle and Hallux Alignment in Patients Undergoing Tarsometatarsal Arthrodesis for Hallux Abducto Valgus: A Case Series and Critical Review of The Literature," *The Journal of Foot and Ankle Surgery*, vol. 52, No. 3, May/June. 2013, pp. 348-354.

Dayton et al., "Quantitative Analysis of the Degree of Frontal Rotation Required to Anatomically Align the First Metatarsal Phalangeal Joint During Modified Tarsal-Metatarsal Arthrodesis Without Capsular Balancing," *The Journal of Foot and Ankle Surgery*, 2015, pp. 1-6.

De Geer et al., "A New Measure of Tibial Sesamoid Position in Hallux Valgus in Relation to the Coronal Rotation of the First Metatarsal in CT Scans," *Foot and Ankle International*, Mar. 26, 2015, 9 pages.

DiDomenico et al., "Correction of Frontal Plane Rotation of Sesamoid Apparatus during the Lapidus Procedure: A Novel Approach," *The Journal of Foot and Ankle Surgery*, vol. 53, 2014, pp. 248-251.

Dobbe et al., "Patient-Tailored Plate for Bone Fixation and Accurate 3D Positioning in Corrective Osteotomy," *Medical and Biological Engineering and Computing*, vol. 51, No. 1-2, Feb. 2013, pp. 19-27, (Abstract Only).

Doty et al., "Hallux valgus and hypermobility of the first ray: facts and fiction," *International Orthopaedics*, vol. 37, 2013, pp. 1655-1660.

EBI Extra Small Rail Fixator, Biomet Trauma, retrieved Dec. 19, 2014, from the Internet: <<http://footandanklefixation.com/product/biomet-trauma-ebi-extra-small-rail-fixator>>, 7 pages.

International Patent Application No. PCT/US2016/018484, International Search Report and Written Opinion mailed Jun. 30, 2016, 12 pages.

"Futura Forefoot Implant Arthroplasty Products," Tornier, Inc., 2008, 14 pages.

Galli et al., "Enhanced Lapidus Arthrodesis: Crossed Screw Technique With Middle Cuneiform Fixation Further Reduces Sagittal Mobility," *The Journal of Foot & Ankle Surgery*, vol. 54, vol. 3, May/June. 2015, published online: Nov. 21, 2014, pp. 437-440.

Garthwait, "Accu-Cut System Facilitates Enhanced Precision," *Podiatry Today*, vol. 18, No. 6, Jun. 2005, 6 pages.

Gonzalez Del Pino et al., "Variable Angle Locking Intercarpal Fusion System for Four-Corner Arthrodesis: Indications and Surgical Technique," *Journal of Wrist Surgery*, vol. 1, No. 1, Aug. 2012, pp. 73-78.

Gotte, "Entwicklung eines Assistenzrobotersystems für die Knieendoprothetik," *Forschungsberichte, Technische Universität München*, 165, 2002, 11 pages, including partial English Translation.

Gregg et al., "Plantar plate repair and Weil osteotomy for metatarsophalangeal joint instability," *Foot and Ankle Surgery*, vol. 13, 2007, pp. 116-121.

Grondal et al., "A Guide Plate for Accurate Positioning of First Metatarsophalangeal Joint during Fusion," *Operative Orthopädie Und Traumatologie*, vol. 16, No. 2, 2004, pp. 167-178 (Abstract Only).

"Hat-Trick Lesser Toe Repair System," Smith & Nephew, Brochure, Aug. 2014, 12 pages.

"Hat-Trick Lesser Toe Repair System, Foot and Ankle Technique Guide, Metatarsal Shortening Osteotomy Surgical Technique," Smith & Nephew, 2014, 16 pages.

(56)

References Cited

OTHER PUBLICATIONS

- Hetherington et al., "Evaluation of surgical experience and the use of an osteotomy guide on the apical angle of an Austin osteotomy," *The Foot*, vol. 18, 2008, pp. 159-164.
- Hirao et al., "Computer assisted planning and custom-made surgical guide for malunited pronation deformity after first metatarsophalangeal joint arthrodesis in rheumatoid arthritis: A case report," *Computer Aided Surgery*, vol. 19, Nos. 1-3, 2014, pp. 13-19.
- "Hoffmann II Compact External Fixation System," Stryker, Brochure, Literature No. 5075-1-500, 2006, 12 pages.
- "Hoffmann II Micro Lengthener," Stryker, Operative Technique, Literature No. 5075-2-002, 2008, 12 pages.
- "Hoffmann Small System External Fixator Orthopedic Instruments," Stryker, retrieved Dec. 19, 2014, from the Internet: <http://www.alibaba.com/product-detail/Stryker-Hoffmann-Small-System-External-Fixator_1438850129.html>, 3 pages.
- Mortier et al., "Axial Rotation of the First Metatarsal Head in a Normal Population and Hallux Valgus Patients," *Orthopaedics and Traumatology: Surgery and Research*, vol. 98, 2012, pp. 677-683.
- Kim et al., "A New Measure of Tibial Sesamoid Position in Hallux Valgus in Relation to the Coronal Rotation of the First Metatarsal in CT Scans," *Foot and Ankle International*, vol. 36, No. 8, 2015, pp. 944-952.
- "Lag Screw Target Bow," Stryker Leibinger GmbH & Co. KG, Germany 2004, 8 pages.
- Lapidus, "The Author's Bunion Operation From 1931 to 1959," *Clinical Orthopaedics*, vol. 16, 1960, pp. 119-135.
- Lieske et al., "Implantation einer Sprunggelenktotalendo-prothese vom Typ Salto 2," *Operative Orthopädie und Traumatologie*, vol. 26, No. 4, 2014, pp. 401-413, including English Abstract on p. 403.
- MAC (Multi Axial Correction) Fixation System, Biomet Trauma, retrieved Dec. 19, 2014, from the Internet: <<http://footandanklefixation.com/product/biomet-trauma-mac-multi-axial-correction-fixation-system>>, 7 pages.
- Magin, "Computernavigierter Gelenkersatz am Knie mit dem Orthopilot," *Operative Orthopädie und Traumatologie*, vol. 22, No. 1, 2010, pp. 63-80, including English Abstract on p. 64.
- Magin, "Die belastungsstabile Lapidus-Arthrodesese bei Hallux-valgus-Deformität mittels IVP-Plattenfixateur (V-TEK-System)," *Operative Orthopädie und Traumatologie*, vol. 26, No. 2, 2014, pp. 184-195, including English Abstract on p. 186.
- Michelangelo Bunion System, Surgical Technique, Instratek Incorporated, publication date unknown, 4 pages.
- Mini Joint Distractor, Arthrex, retrieved Dec. 19, 2014, from the Internet: <<http://www.arthrex.com/foot-ankle/mini-joint-distractor/products>>, 2 pages.
- MiniRail System, Small Bone Innovations, Surgical Technique, 2010, 24 pages.
- Miyake et al., "Three-Dimensional Corrective Osteotomy for Malunited Diaphyseal Forearm Fractures Using Custom-Made Surgical Guides Based on Computer Simulation," *JBJS Essential Surgical Techniques*, vol. 2, No. 4, 2012, 11 pages.
- Modular Rail System: External Fixator, Smith & Nephew, Surgical Technique, 2013, 44 pages.
- Monnich et al., "A Hand Guided Robotic Planning System for Laser Osteotomy in Surgery," *World Congress on Medical Physics and Biomedical Engineering vol. 25/6: Surgery, Minimal Invasive Interventions, Endoscopy and Image Guided Therapy*, Sep. 7-12, 2009, pp. 59-62, (Abstract Only).
- Moore et al., "Effect of Ankle Flexion Angle on Axial Alignment of Total Ankle Replacement," *Foot and Ankle International*, vol. 31, No. 12, Dec. 2010, pp. 1093-1098, (Abstract Only).
- Yasuda et al., "Proximal Supination Osteotomy of the First Metatarsal for Hallux Valgus," *Foot and Ankle International*, vol. 36, No. 6, Jun. 2015, pp. 696-704.
- Defendant Fusion Orthopedics LLC's Invalidity Contentions, No. CV-22-00490-PHX-SRB, US District Court for the District of Arizona, Aug. 27, 2022, 41 pages.
- Prior Art Publications, Exhibit A of Defendant Fusion Orthopedics LLC's Invalidity Contentions, No. CV-22-00490-PHX-SRB, US District Court for the District of Arizona, Aug. 27, 2022, 3 pages.
- Claim Chart for Fishco, "Making the Lapidus Easy," *The Podiatry Institute* (Apr. 2014), Exhibit B1 of Defendant Fusion Orthopedics LLC's Invalidity Contentions, No. CV-22-00490-PHX-SRB, US District Court for the District of Arizona, Aug. 27, 2022, 97 pages.
- Claim Chart for Fishco, "A Straightforward Guide to the Lapidus Bunionectomy," *HMP Global* (Sep. 6, 2013), Exhibit B2 of Defendant Fusion Orthopedics LLC's Invalidity Contentions, No. CV-22-00490-PHX-SRB, US District Court for the District of Arizona, Aug. 27, 2022, 67 pages.
- Claim Chart for Groves, "Functional Position Joint Sectioning: Pre-Load Method for Lapidus Arthrodesis," *Update 2015: Proceedings of the Annual Meeting of the Podiatry Institute*, Chpt. 6, pp. 23-29 (Apr. 2015), Exhibit B3 of Defendant Fusion Orthopedics LLC's Invalidity Contentions, No. CV-22-00490-PHX-SRB, US District Court for the District of Arizona, Aug. 27, 2022, 151 pages.
- Claim Chart for Mote, "First Metatarsal-Cuneiform Arthrodesis for the Treatment of First Ray Pathology: A Technical Guide," *The Journal Foot & Ankle Surgery* (Sep. 1, 2009), Exhibit B5 of Defendant Fusion Orthopedics LLC's Invalidity Contentions, No. CV-22-00490-PHX-SRB, US District Court for the District of Arizona, Aug. 27, 2022, 21 pages.
- Claim Chart for U.S. Pat. No. 10,376,268 to Fallin et al., entitled "Indexed Tri-Planar Osteotomy Guide and Method," issued Aug. 13, 2019, Exhibit B6 of Defendant Fusion Orthopedics LLC's Invalidity Contentions, No. CV-22-00490-PHX-SRB, US District Court for the District of Arizona, Aug. 27, 2022, 155 pages.
- Claim Chart for U.S. Pat. No. 8,282,645 to Lawrence et al., entitled "Metatarsal Bone Implant Cutting Guide," issued Jan. 18, 2010, Exhibit B7 of Defendant Fusion Orthopedics LLC's Invalidity Contentions, No. CV-22-00490-PHX-SRB, US District Court for the District of Arizona, Aug. 27, 2022, 76 pages.
- Claim Chart for U.S. Pat. No. 9,452,057 to Dacosta et al., entitled "Bone Implants and Cutting Apparatuses and Methods," issued Apr. 8, 2011, Exhibit B8 of Defendant Fusion Orthopedics LLC's Invalidity Contentions, No. CV-22-00490-PHX-SRB, US District Court for the District of Arizona, Aug. 27, 2022, 110 pages.
- Obviousness Chart, Exhibit C of Defendant Fusion Orthopedics LLC's Invalidity Contentions, No. CV-22-00490-PHX-SRB, US District Court for the District of Arizona, Aug. 27, 2022, 153 pages.
- "Foot and Ankle Instrument Set," Smith & Nephew, 2013, 2 pages.
- "Lapidus Pearls: Gaining Joint Exposure to Decrease Non-Union," *Youtube*, Retrieved online from <<https://www.youtube.com/watch?v=-jqJyE7pj-Y>>, dated Nov. 2, 2009, 3 pages.
- "Reconstructive Surgery of the Foot & Ankle," *The Podiatry Institute*, Update 2015, Conference Program, May 2015, 28 pages.
- "Speed Continuous Active Compression Implant," *BioMedical Enterprises, Inc.*, A120-029 Rev. 3, 2013, 4 pages.
- "Visionaire: Patient Matched Cutting Blocks Surgical Procedure," Smith & Nephew, Inc., 2009, 2 pages.
- Arthrex, "Comprehensive Foot System," Retrieved online from <https://www.arthrex.com/resources/animation/8U3iaPvY6kO8bwFAwZF50Q/comprehensive-foot-system?referringTeam=foot_and_ankle>, dated Aug. 27, 2013, 3 pages.
- Baravarian, "Why the Lapidus Procedure is Ideal for Bunions," *Podiatry Today*, Retrieved online from <<https://www.hmpglobal-learnhmpglobal.com/site/podipodi/article/5542>>, dated May 2006, 8 pages.
- Bauer et al., "Offset-V Osteotomy of the First Metatarsal Shaft in Hallux Abducto Valgus," *McGlamry's Comprehensive Textbook of Foot and Ankle Surgery*, Fourth Edition, vol. 1, Chapter 29, 2013, 26 pages.
- Cottom, "Fixation of the Lapidus Arthrodesis with a Plantar Interfragmentary Screw and Medial Low Profile Locking Plate," *The Journal of Foot & Ankle Surgery*, vol. 51, 2012, pp. 517-522.
- Coughlin, "Fixation of the Lapidus Arthrodesis with a Plantar Interfragmentary Screw and Medial Low Profile Locking Plate," *Orthopaedics and Traumatology*, vol. 7, 1999, pp. 133-143.

(56)

References Cited

OTHER PUBLICATIONS

- Dayton et al., "Observed Changes in Radiographic Measurements of the First Ray after Frontal Plane Rotation of the First Metatarsal in a Cadaveric Foot Model," *The Journal of Foot & Ankle Surgery*, vol. 53, 2014, pp. 274-278.
- Dayton et al., "Relationship of Frontal Plane Rotation of First Metatarsal to Proximal Articular Set Angle and Hallux Alignment in Patients Undergoing Tarsometatarsal Arthrodesis for Hallux Abducto Valgus: A Case Series and Critical Review of the Literature," *The Journal of Foot & Ankle Surgery*, 2013, Article in Press, Mar. 1, 2013, 7 pages.
- DiDomenico et al., "Lapidus Bunionectomy: First Metatarsal-Cuneiform Arthrodesis," *McGlamry's Comprehensive Textbook of Foot and Ankle Surgery*, Fourth Edition, vol. 1, Chapter 31, 2013, 24 pages.
- Fallin et al., US Provisional Application Entitled Indexed Tri-Planar Osteotomy Guide and Method, U.S. Appl. No. 62/118,378, filed Feb. 19, 2015, 62 pages.
- Fishco, "A Straightforward Guide to The Lapidus Bunionectomy," *Podiatry Today*, Retrieved online from <<https://www.hmpglobal-learningnetwork.com/site/podiatry/blogged/straightforward-guide-lapidus-bunionectomy>>, dated Sep. 6, 2013, 5 pages.
- Fishco, "Making the Lapidus Easy," *The Podiatry Institute*, Update 2014, Chapter 14, 2014, pp. 91-93.
- Fleming et al., "Results of Modified Lapidus Arthrodesis Procedure Using Medial Eminence as an Interpositional Autograft," *The Journal of Foot & Ankle Surgery*, vol. 50, 2011, pp. 272-275.
- Fuhrmann, "Arthrodesis of the First Tarsometatarsal Joint for Correction of the Advanced Splayfoot Accompanied by a Hallux Valgus," *Operative Orthopädie und Traumatologie*, No. 2, 2005, pp. 195-210.
- Gerard et al., "The Modified Lapidus Procedure," *Orthopedics*, vol. 31, No. 3, Mar. 2008, 7 pages.
- Giannoudis et al., "Hallux Valgus Correction," *Practical Procedures in Elective Orthopaedic Surgery, Pelvis and Lower Extremity*, Chapter 38, 2012, 22 pages.
- Greiner, "The Jargon of Pedal Movements," *Foot & Ankle International*, vol. 28, No. 1, Jan. 2007, pp. 109-125.
- Groves, "Functional Position Joint Sectioning: Pre-Load Method for Lapidus Arthrodesis," *The Podiatry Institute*, Update 2015, Chapter 6, 2015, pp. 23-29.
- Hardy et al., "Observations on Hallux Valgus," *The Journal of Bone and Joint Surgery*, vol. 33B, No. 3, Aug. 1951, pp. 376-391.
- Holmes, Jr., "Correction of the Intermetatarsal Angle Component of Hallux Valgus Using Fiberwire-Attached Endo-buttons," *Revista Internacional de Ciencias Podológicas*, vol. 6, No. 2, 2012, pp. 73-79.
- Integra, "Integra Large Qwix Positioning and Fixation Screw, Surgical Technique," 2012, 16 pages.
- Kilmartin et al., "Combined rotation scarf and Akin osteotomies for hallux valgus: a patient focused 9 year follow up of 50 patients," *Journal of Foot and Ankle Research*, vol. 3, No. 2, 2010, 12 pages.
- Lee et al., "Technique Tip: Lateral Soft-Tissue Release for Correction of Hallux Valgus Through a Medial Incision Using a Dorsal Flap Over the First Metatarsal," *Foot & Ankle International*, vol. 28, No. 8, Aug. 2007, pp. 949-951.
- Mote et al., "First Metatarsal-Cuneiform Arthrodesis for the Treatment of First Ray Pathology: A Technical Guide," *JFAS Techniques Guide*, vol. 48, No. 5, Sep./Oct. 2009, pp. 593-601.
- Myerson, "Cuneiform-Metatarsal Arthrodesis," *The Foot and Ankle*, Chapter 9, 1997, pp. 107-117.
- Sammarco, "Surgical Strategies: Mau Osteotomy for Correction of Moderate and Severe Hallux Valgus Deformity," *Foot & Ankle International*, vol. 28, No. 7, Jul. 2007, pp. 857-864.
- Schon et al., "Cuneiform-Metatarsal Arthrodesis for Hallux Valgus," *The Foot and Ankle*, Second Edition, Chapter 8, 2002, pp. 99-117.
- Sokoloff, "Lapidus Procedure," *Textbook of Bunion Surgery*, Chapter 15, 1981, pp. 277-287.
- Stamatis et al., "Mini Locking Plate as "Medial Buttress" for Oblique Osteotomy for Hallux Valgus," *Foot & Ankle International*, vol. 31, No. 10, Oct. 2010, pp. 920-922.
- Stewart, "Use for BME Speed Nitinol Staple Fixation for the Lapidus Procedure," date unknown, 1 page.
- Wukich et al., "Hypermobility of the First Tarsometatarsal Joint," *Foot and Ankle Clinics*, vol. 10, No. 1, Mar. 2005, pp. 157-166.
- Dayton et al., "Biwinged Excision for Round Pedal Lesions," *The Journal of Foot and Ankle Surgery*, vol. 35, No. 3, 1996, pp. 244-249.
- Dayton et al., "Medial Incision Approach to the First Metatarsophalangeal Joint," *The Journal of Foot and Ankle Surgery*, vol. 40, No. 6, Nov./Dec. 2001, pp. 414-417.
- Dayton et al., "Reduction of the Intermetatarsal Angle after First Metatarsophalangeal Joint Arthrodesis in Patients with Moderate and Severe Metatarsus Primus Adductus," *The Journal of Foot and Ankle Surgery*, vol. 41, No. 5, Sep./Oct. 2002, pp. 316-319.
- Dayton et al., "Use of the Z Osteotomy for Tailor Bunionectomy," *The Journal of Foot and Ankle Surgery*, vol. 42, No. 3, May/Jun. 2003, pp. 167-169.
- Dayton et al., "Early Weightbearing After First Metatarsophalangeal Joint Arthrodesis: A Retrospective Observational Case Analysis," *The Journal of Foot and Ankle Surgery*, vol. 43, No. 3, May/Jun. 2004, pp. 156-159.
- Dayton et al., "Dorsal Suspension Stitch: An Alternative Stabilization After Flexor Tenotomy for Flexible Hammer Digit Syndrome," *The Journal of Foot and Ankle Surgery*, vol. 48, No. 5, Sep./Oct. 2009, pp. 602-605.
- Dayton et al., "The Extended Knee Hemilithotomy Position for Gastrocnemius Recession," *The Journal of Foot and Ankle Surgery*, vol. 49, 2010, pp. 214-216.
- Wienke et al., "Bone Stimulation For Nonunions: What the Evidence Reveals," *Podiatry Today*, vol. 24, No. 9, Sep. 2011, pp. 52-57.
- Dayton et al., "Hallux Varus as Complication of Foot Compartment Syndrome," *The Journal of Foot and Ankle Surgery*, vol. 50, 2011, pp. 504-506.
- Dayton et al., "Measurement of Mid-Calcaneal Length on Plain Radiographs: Reliability of a New Method," *Foot and Ankle Specialist*, vol. 4, No. 5, Oct. 2011, pp. 280-283.
- Dayton et al., "A User-Friendly Method of Pin Site Management for External Fixators," *Foot and Ankle Specialist*, Sep. 16, 2011, 4 pages.
- Dayton et al., "Effectiveness of a Locking Plate in Preserving Midcalcaneal Length and Positional Outcome after Evans Calcaneal Osteotomy: A Retrospective Pilot Study," *The Journal of Foot and Ankle Surgery*, vol. 52, 2013, pp. 710-713.
- Dayton et al., "Does Postoperative Showering or Bathing of a Surgical Site Increase the Incidence of Infection? A Systematic Review of the Literature," *The Journal of Foot and Ankle Surgery*, vol. 52, 2013, pp. 612-614.
- Dayton et al., "Technique for Minimally Invasive Reduction of Calcaneal Fractures Using Small Bilateral External Fixation," *The Journal of Foot and Ankle Surgery*, Article in Press, 2014, 7 pages.
- Dayton et al., "Clarification of the Anatomic Definition of the Bunion Deformity," *The Journal of Foot and Ankle Surgery*, vol. 53, 2014, pp. 160-163.
- Dayton et al., "Observed Changes in Radiographic Measurements of the First Ray after Frontal Plane Rotation of the First Metatarsal in a Cadaveric Foot Model," *The Journal of Foot and Ankle Surgery*, Article in Press, 2014, 5 pages.
- Dayton et al., "Observed Changes in First Metatarsal and Medial Cuneiform Positions after First Metatarsophalangeal Joint Arthrodesis," *The Journal of Foot and Ankle Surgery*, vol. 53, 2014, pp. 32-35.
- Dayton et al., "Reduction of the Intermetatarsal Angle after First Metatarsal Phalangeal Joint Arthrodesis: A Systematic Review," *The Journal of Foot and Ankle Surgery*, Article in Press, 2014, 4 pages.
- Feilmeier et al., "Reduction of Intermetatarsal Angle after First Metatarsophalangeal Joint Arthrodesis in Patients with Hallux Valgus," *The Journal of Foot and Ankle Surgery*, vol. 53, 2014, pp. 29-31.

(56)

References Cited

OTHER PUBLICATIONS

- Dayton et al., "Principles of Management of Growth Plate Fractures in the Foot and Ankle," *Clinics in Podiatric Medicine and Surgery, Pediatric Foot Deformities*, Oct. 2013, 17 pages.
- Dayton et al., "Observed Changes in Radiographic Measurements of the First Ray after Frontal and Transverse Plane Rotation of the Hallux: Does the Hallux Drive the Metatarsal in a Bunion Deformity?," *The Journal of Foot and Ankle Surgery*, Article in Press, 2014, 4 pages.
- Rodriguez et al., "Ilizarov method of fixation for the management of pilon and distal tibial fractures in the compromised diabetic patient: A technique guide," *The Foot and Ankle Journal Online*, vol. 7, No. 2, 2014, 9 pages.
- Feilmeier et al., "Incidence of Surgical Site Infection in the Foot and Ankle with Early Exposure and Showering of Surgical Sites: A Prospective Observation," *The Journal of Foot and Ankle Surgery*, vol. 53, 2014, pp. 173-175.
- Catanese et al., "Measuring Sesamoid Position in Hallux Valgus: When Is the Sesamoid Axial View Necessary," *Foot and Ankle Specialist*, 2014, 3 pages.
- Dayton et al., "Comparison of Complications for Internal and External Fixation for Charcot Reconstruction: A Systematic Review," *The Journal of Foot and Ankle Surgery*, Article in Press, 2015, 4 pages.
- Dayton et al., "A new triplanar paradigm for bunion management," *Lower Extremity Review*, Apr. 2015, 9 pages.
- Dayton et al., "American College of Foot and Ankle Surgeons' Clinical Consensus Statement: Perioperative Prophylactic Antibiotic Use in Clean Elective Foot Surgery," *The Journal of Foot and Ankle Surgery*, Article in Press, 2015, 7 pages.
- Dayton et al., "Complications of Metatarsal Suture Techniques for Bunion Correction: A Systematic Review of the Literature," *The Journal of Foot and Ankle Surgery*, Article in Press, 2015, 3 pages.
- DeCarbo et al., "The Weil Osteotomy: A Refresher," *Techniques in Foot and Ankle Surgery*, vol. 13, No. 4, Dec. 2014, pp. 191-198.
- DeCarbo et al., "Resurfacing Interpositional Arthroplasty for Degenerative Joint Diseases of the First Metatarsalphalangeal Joint," *Podiatry Management*, Jan. 2013, pp. 137-142.
- DeCarbo et al., "Locking Plates: Do They Prevent Complications?," *Podiatry Today*, Apr. 2014, 7 pages.
- Easley et al., "Current Concepts Review: Hallux Valgus Part II: Operative Treatment," *Foot and Ankle International*, vol. 28, No. 6, Jun. 2007, pp. 748-758.
- Kim et al., "A Multicenter Retrospective Review of Outcomes for Arthrodesis, Hemi-Metallic Joint Implant, and Resectional Arthroplasty in the Surgical Treatment of End-Stage Hallux Rigidus," *The Journal of Foot and Ankle Surgery*, vol. 51, 2012, pp. 50-56.
- Easley et al., "Current Concepts Review: Hallux Valgus Part I: Pathomechanics, Clinical Assessment, and Nonoperative Management," *Foot and Ankle International*, vol. 28, No. 5, May 2007, pp. 654-659.
- Sandhu et al., "Digital Arthrodesis With a One-Piece Memory Nitinol Intramedullary Fixation Device: A Retrospective Review," *Foot and Ankle Specialist*, vol. 6, No. 5, Oct. 2013, pp. 364-366.
- Weber et al., "Use of the First Ray Splay Test to Assess Transverse Plane Instability Before First Metatarsocuneiform Fusion," *The Journal of Foot and Ankle Surgery*, vol. 45, No. 4, Jul./Aug. 2006, pp. 278-282.
- Smith et al., "Opening Wedge Osteotomies for Correction of Hallux Valgus: A Review of Wedge Plate Fixation," *Foot and Ankle Specialist*, vol. 2, No. 6, Dec. 2009, pp. 277-282.
- Easley et al., "What is the Best Treatment for Hallux Valgus?," *Evidence-Based Orthopaedics—The Best Answers to Clinical Questions*, Chapter 73, 2009, pp. 479-491.
- Shurnas et al., "Proximal Metatarsal Opening Wedge Osteotomy," *Operative Techniques in Foot and Ankle Surgery*, Section I, Chapter 13, 2011, pp. 73-78.
- Coetzee et al., "Revision Hallux Valgus Correction," *Operative Techniques in Foot and Ankle Surgery*, Section I, Chapter 15, 2011, pp. 84-96.
- Le et al., "Tarsometatarsal Arthrodesis," *Operative Techniques in Foot and Ankle Surgery*, Section II, Chapter 40, 2011, pp. 281-285.
- Collan et al., "The biomechanics of the first metatarsal bone in hallux valgus: A preliminary study utilizing a weight bearing extremity CT," *Foot and Ankle Surgery*, vol. 19, 2013, pp. 155-161.
- Eustace et al., "Hallux valgus, first metatarsal pronation and collapse of the medial longitudinal arch—a radiological correlation," *Skeletal Radiology*, vol. 23, 1994, pp. 191-194.
- Mizuno et al., "Detorsion Osteotomy of the First Metatarsal Bone in Hallux Valgus," *Japanese Orthopaedic Association, Tokyo*, 1956; 30:813-819.
- Okuda et al., "The Shape of the Lateral Edge of the First Metatarsal Head as a Risk Factor for Recurrence of Hallux Valgus," *The Journal of Bone and Joint Surgery*, vol. 89, 2007, pp. 2163-2172.
- Okuda et al., "Proximal Metatarsal Osteotomy for Hallux Valgus: Comparison of Outcome for Moderate and Severe Deformities," *Foot and Ankle International*, vol. 29, No. 7, Jul. 2008, pp. 664-670.
- D'Amico et al., "Motion of the First Ray: Clarification Through Investigation," *Journal of the American Podiatry Association*, vol. 69, No. 1, Jan. 1979, pp. 17-23.
- Groves, "Operative Report," *St. Tammany Parish Hospital*, Date of Procedure, Mar. 26, 2014, 2 pages.
- Claim Chart for Groves Public Use (Mar. 26, 2014), Exhibit B4 of Defendant Fusion Orthopedics LLC's Invalidity Contentions, No. CV-22-00490-PHX-SRB, US District Court for the District of Arizona, Aug. 27, 2022, 161 pages.
- Nagy et al., "The AO Ulnar Shortening Osteotomy System Indications and Surgical Technique," *Journal of Wrist Surgery*, vol. 3, No. 2, 2014, pp. 91-97.
- NexFix from Nexa Orthopedics, MetaFix I from Merete Medical, Inc. and The BioPro Lower Extremities from BioPro, found in *Foot & Ankle International Journal*, vol. 28, No. 1, Jan. 2007, 4 pages.
- Odenbring et al., "A guide instrument for high tibial osteotomy," *Acta Orthopaedica Scandinavica*, vol. 60, No. 4, 1989, pp. 449-451.
- Okuda et al., "Postoperative Incomplete Reduction of the Sesamoids as a Risk Factor for Recurrence of Hallux Valgus," *The Journal of Bone and Joint Surgery*, vol. 91-A, No. 1, Jul. 2009, pp. 1637-1645.
- Osher et al., "Accurate Determination of Relative Metatarsal Protrusion with a Small Intermetatarsal Angle: A Novel Simplified Method," *The Journal of Foot & Ankle Surgery*, vol. 53, No. 5, Sep./Oct. 2014, published online: Jun. 3, 2014, pp. 548-556.
- Otsuki et al., "Developing a novel custom cutting guide for curved per-acetabular osteotomy," *International Orthopaedics (SICOT)*, vol. 37, 2013, pp. 1033-1038.
- Patel et al., "Modified Lapidus Arthrodesis: Rate of Nonunion in 227 Cases," *The Journal of Foot & Ankle Surgery*, vol. 43, No. 1, Jan./Feb. 2004, pp. 37-42.
- "Patient to Patient Precision, Accu-Cut, Osteotomy Guide System," *BioPro, Foot & Ankle International Journal*, vol. 23, No. 8, Aug. 2002, 2 pages.
- Peters et al., "Flexor Hallucis Longus Tendon Laceration as a Complication of Total Ankle Arthroplasty," *Foot & Ankle International*, vol. 34, No. 1, 2013, pp. 148-149.
- "Prophecy Inbone Preoperative Navigation Guides," *Wright Medical Technology, Inc.*, Nov. 2013, 6 pages.
- "Rayhack Ulnar Shortening Generation II Low-Profile Locking System Surgical Technique," *Wright Medical Technology, Inc.*, Dec. 2013, 20 pages.
- Rx-Fix Mini Rail External Fixator, *Wright Medical Technology*, Brochure, Aug. 15, 2014, 2 pages.
- Saltzman et al., "Prospective Controlled Trial of Star Total Ankle Replacement Versus Ankle Fusion: Initial Results," *Foot & Ankle International*, vol. 30, No. 7, Jul. 2009, pp. 579-596.
- Scanlan et al., "Technique Tip: Subtalar Joint Fusion Using a Parallel Guide and Double Screw Fixation," *The Journal of Foot and Ankle Surgery*, vol. 49, Issue 3, May-Jun. 2010, pp. 305-309, (Abstract Only).
- Scranton Jr. et al., "Anatomic Variations in the First Ray: Part I. Anatomic Aspects Related to Bunions Surgery," *Clinical Orthopaedics and Related Research*, vol. 151, Sep. 1980, pp. 244-255.
- Siddiqui et al., "Fixation of Metatarsal Fracture With Bone Plate in a Dromedary Heifer," *Open Veterinary Journal*, vol. 3, No. 1, 2013, pp. 17-20.

(56)

References Cited

OTHER PUBLICATIONS

Sidekick Stealth Rearfoot Fixator, Wright Medical Technology, Surgical Technique, Dec. 2, 2013, 20 pages.

Simpson et al., "Computer-Assisted Distraction Osteogenesis by Ilizarov's Method," *International Journal of Medical Robots and Computer Assisted Surgery*, vol. 4, No. 4, Dec. 2008, pp. 310-320, (Abstract Only).

Small Bone External Fixation System, Acumed, Surgical Technique, Effective date Sep. 2014, 8 pages.

"Smith & Nephew scores a Hat-Trick with its entry into the high-growth hammer toe repair market," *Smith & Nephew*, Jul. 31, 2014, 2 pages.

Stableloc External Fixation System, Acumed, Product Overview, Effective date Sep. 2015, 4 pages.

Stahl et al., "Derotation of Post-Traumatic Femoral Deformities by Closed Intramedullary Sawing," *Injury*, vol. 37, No. 2, Feb. 2006, pp. 145-151, (Abstract Only).

Talbot et al., "Assessing Sesamoid Subluxation: How Good is the AP Radiograph?," *Foot and Ankle International*, vol. 19, No. 8, Aug. 1998, pp. 547-554.

TempFix Spanning the Ankle Joint Half Pin and Transfixing Pin Techniques, Biomet Orthopedics, Surgical Technique, 2012, 16 pages.

Toth et al., "The Effect of First Ray Shortening in the Development of Metatarsalgia in the Second Through Fourth Rays After Metatarsal Osteotomy," *Foot & Ankle International*, vol. 28, No. 1, Jan. 2007, pp. 61-63.

Tricot et al., "3D-corrective osteotomy using surgical guides for posttraumatic distal humeral deformity," *Acta Orthopaedica Belgica*, vol. 78, No. 4, 2012, pp. 538-542.

Vitek et al., "Die Behandlung des Hallux rigidus mit Cheilektomie und Akin-Moberg-Osteotomie unter Verwendung einer neuen Schnittlehre und eines neuen Schraubensystems," *Orthopadische Praxis*, vol. 44, Nov. 2008, pp. 563-566, including English Abstract on p. 564.

Vitek, "Neue Techniken in der Fußchirurgie Das V-tek-System," *ABW Wissenschaftsverlag GmbH*, 2009, 11 pages, including English Abstract.

Weber et al., "A Simple System for Navigation of Bone Alignment Osteotomies of The Tibia," *International Congress Series*, vol. 1268, Jan. 2004, pp. 608-613, (Abstract Only).

Weil et al., "Anatomic Plantar Plate Repair Using the Weil Metatarsal Osteotomy Approach," *Foot & Ankle Specialist*, vol. 4, No. 3, 2011, pp. 145-150.

Wendl et al., "Navigation in der Knieendoprothetik," *OP-Journal*, vol. 17, 2002, pp. 22-27, including English Abstract.

Whipple et al., "Zimmer Herbert Whipple Bone Screw System: Surgical Techniques for Fixation of Scaphoid and Other Small Bone Fractures," *Zimmer*, 2003, 59 pages.

Yackacki et al., "Compression Forces of Internal and External Ankle Fixation Devices with Simulated Bone Resorption," *Foot and Ankle International*, vol. 31, No. 1, Jan. 2010, pp. 76-85, (Abstract Only).

* cited by examiner

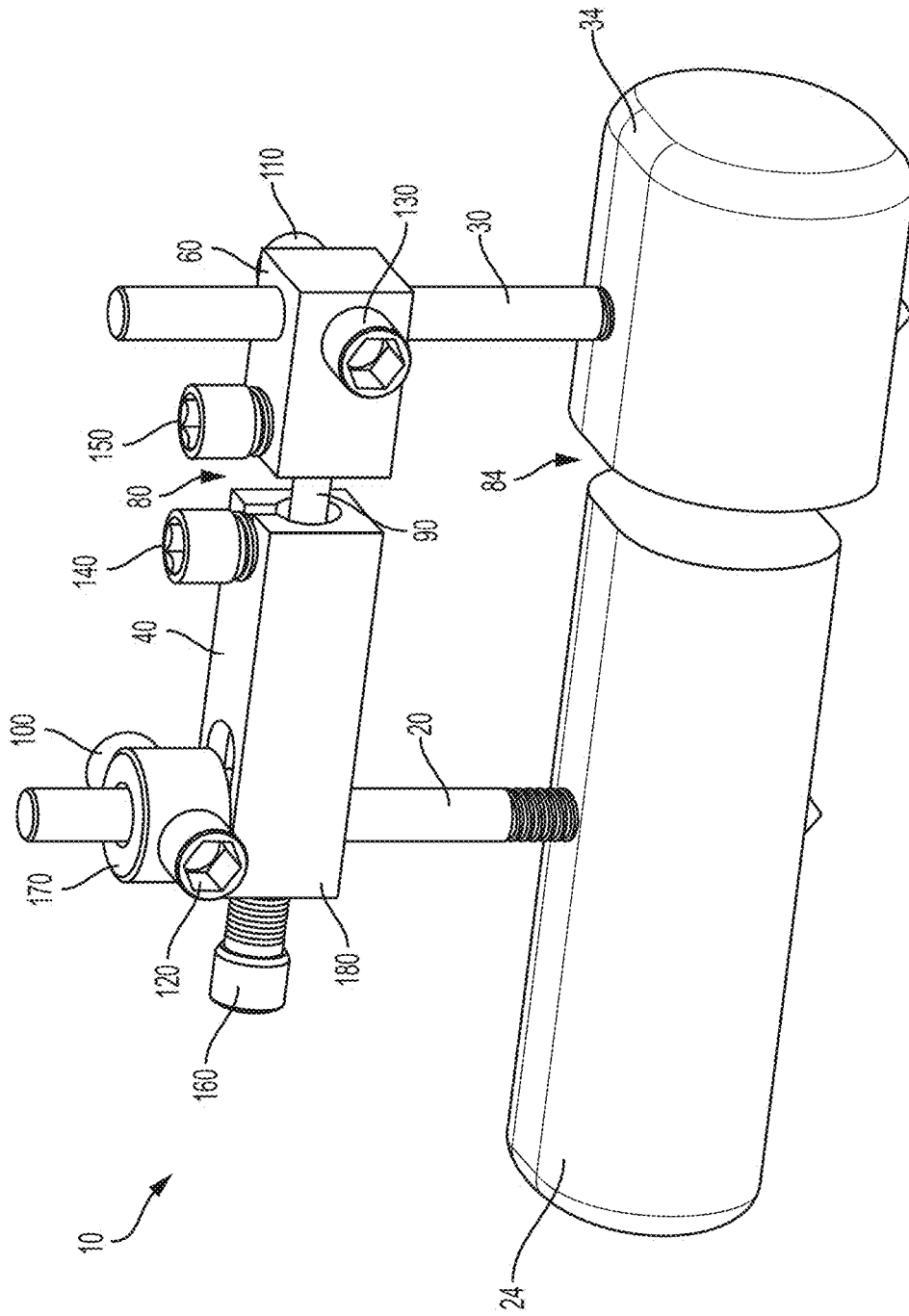

FIG. 1

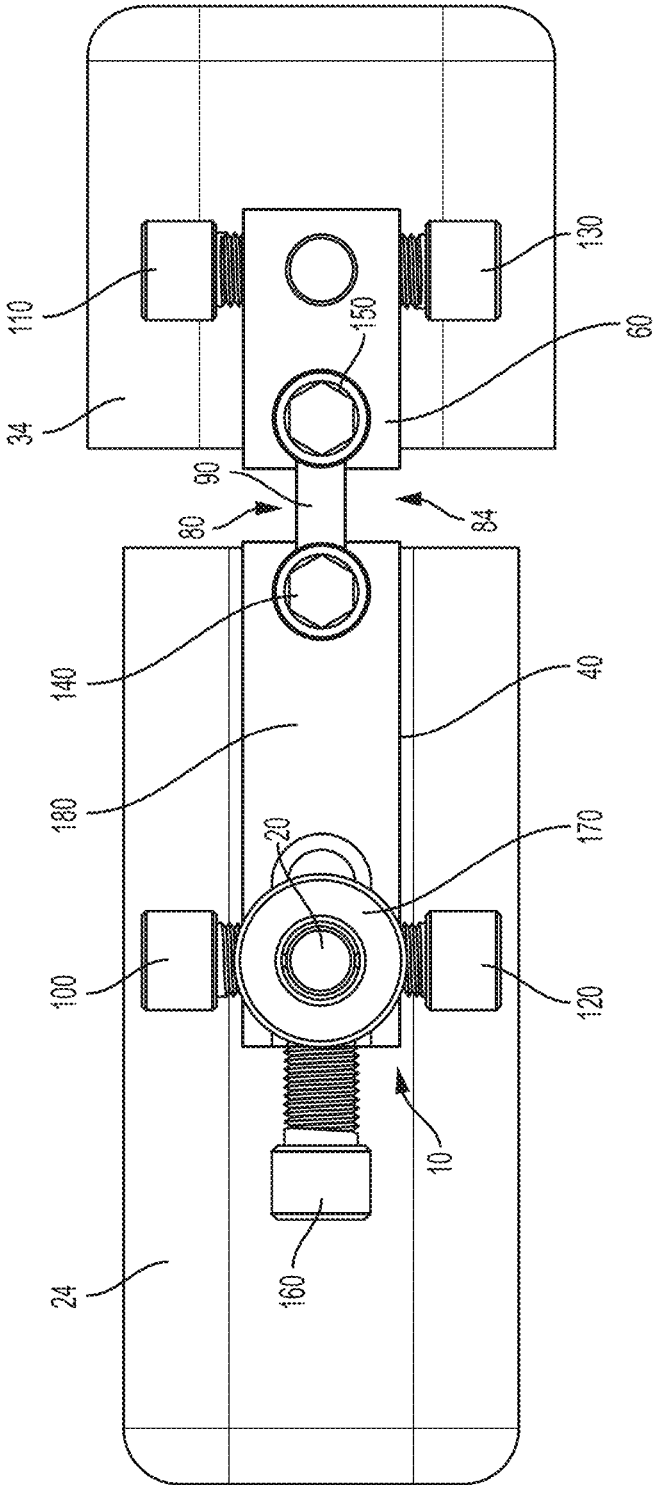

FIG. 2

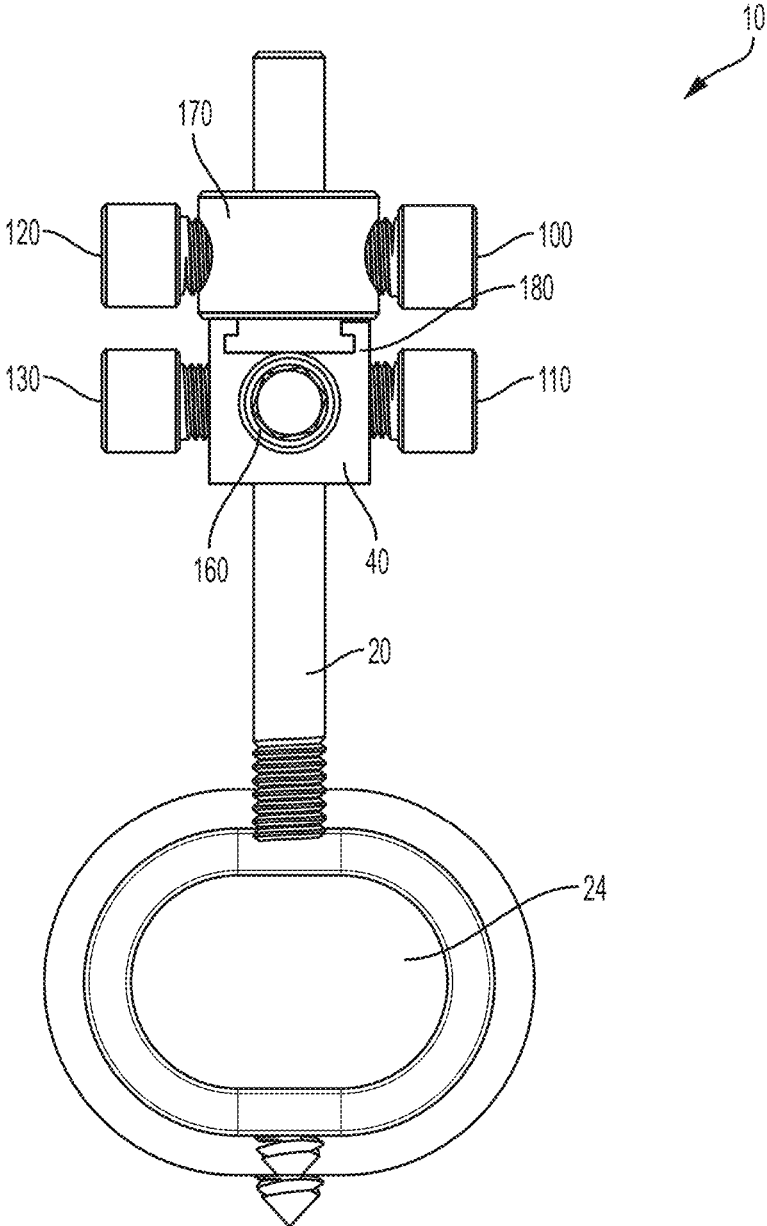

FIG. 3

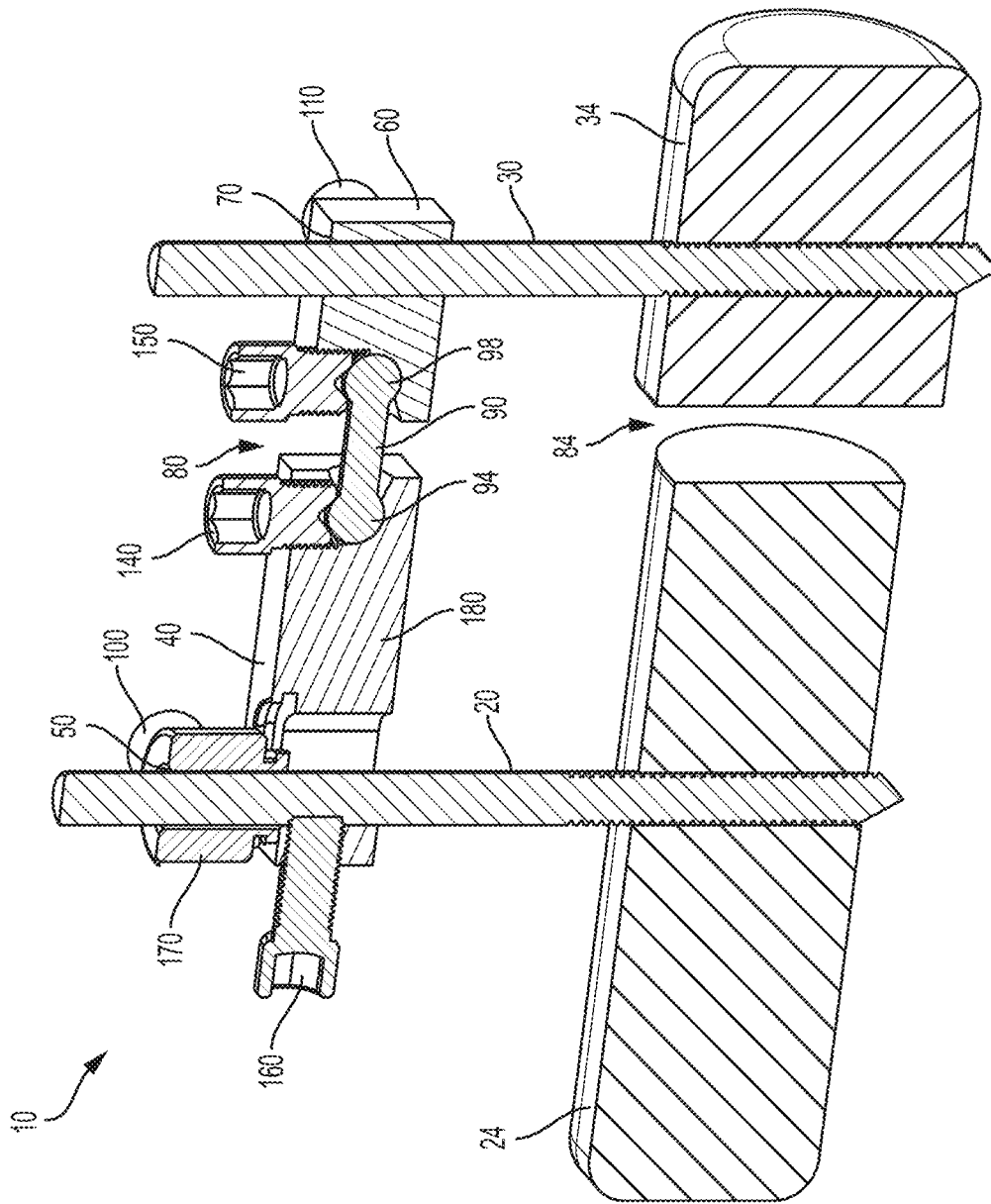

FIG. 4

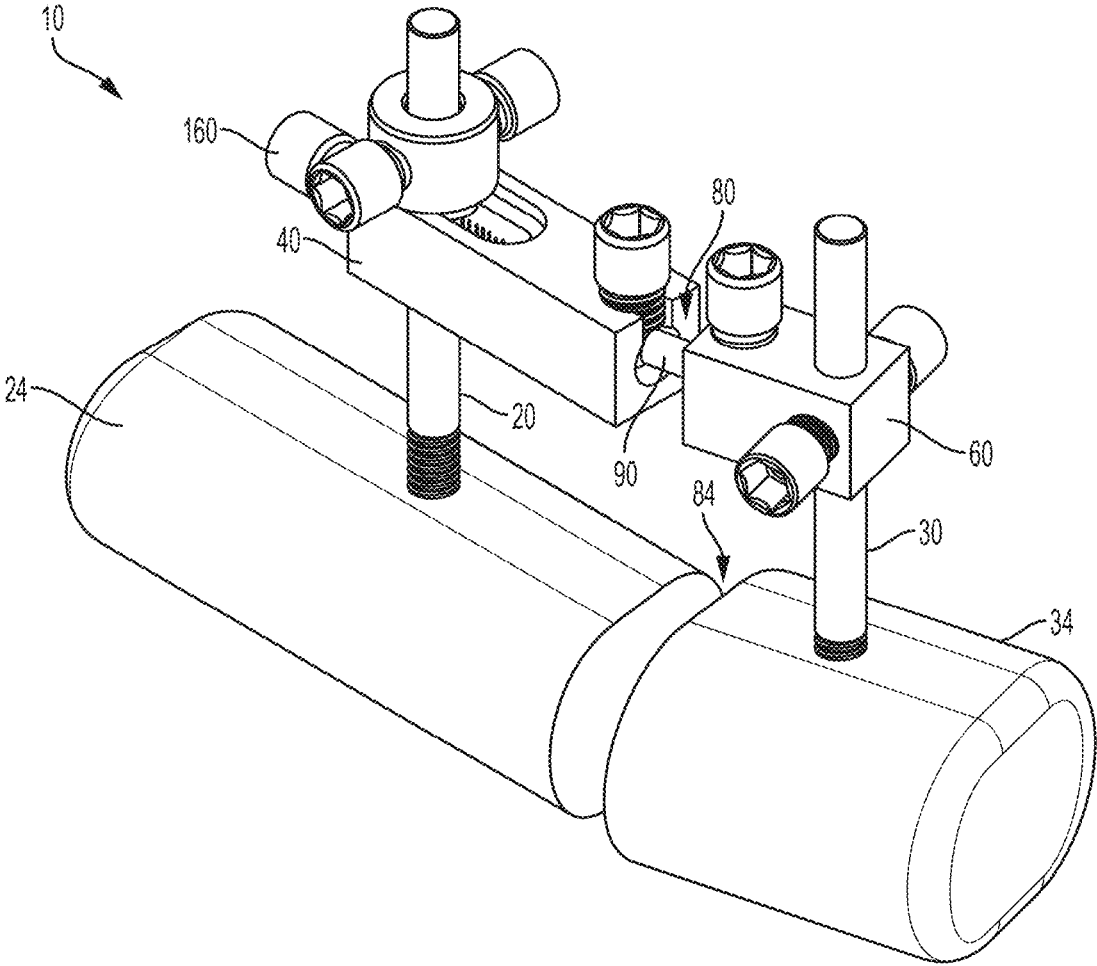

FIG. 5

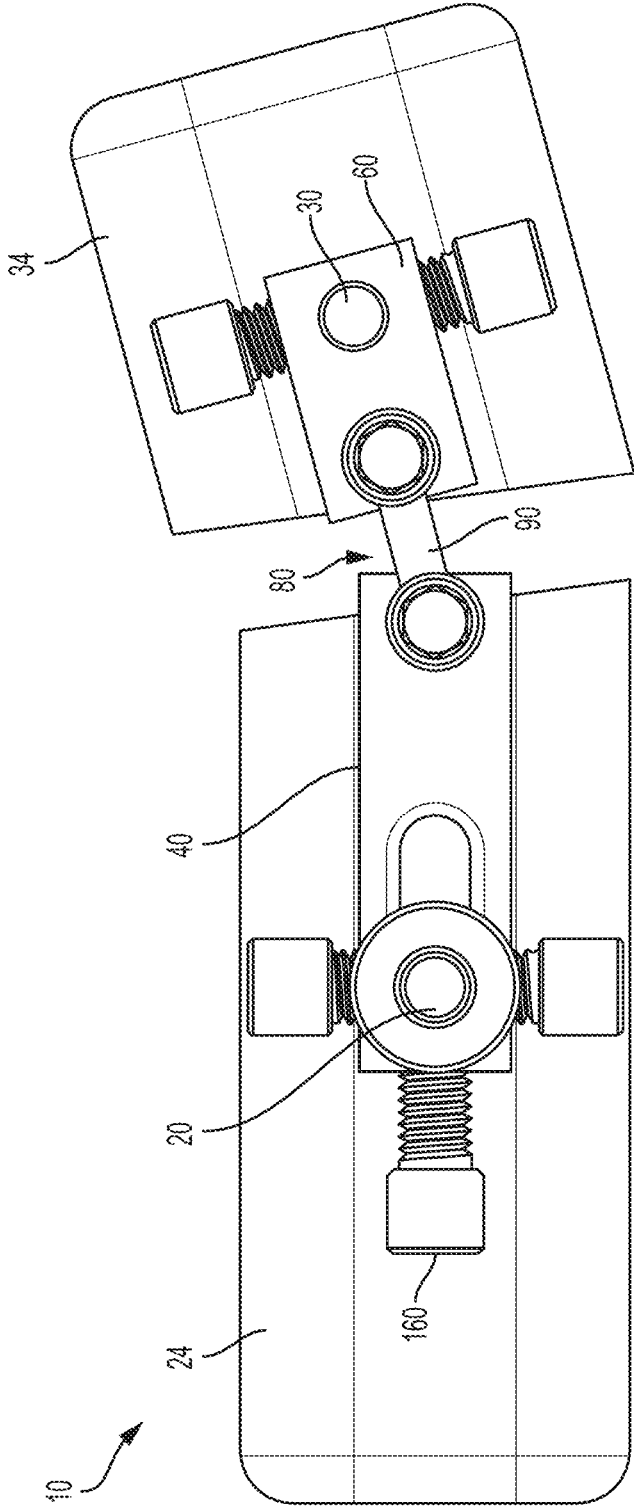

FIG. 6

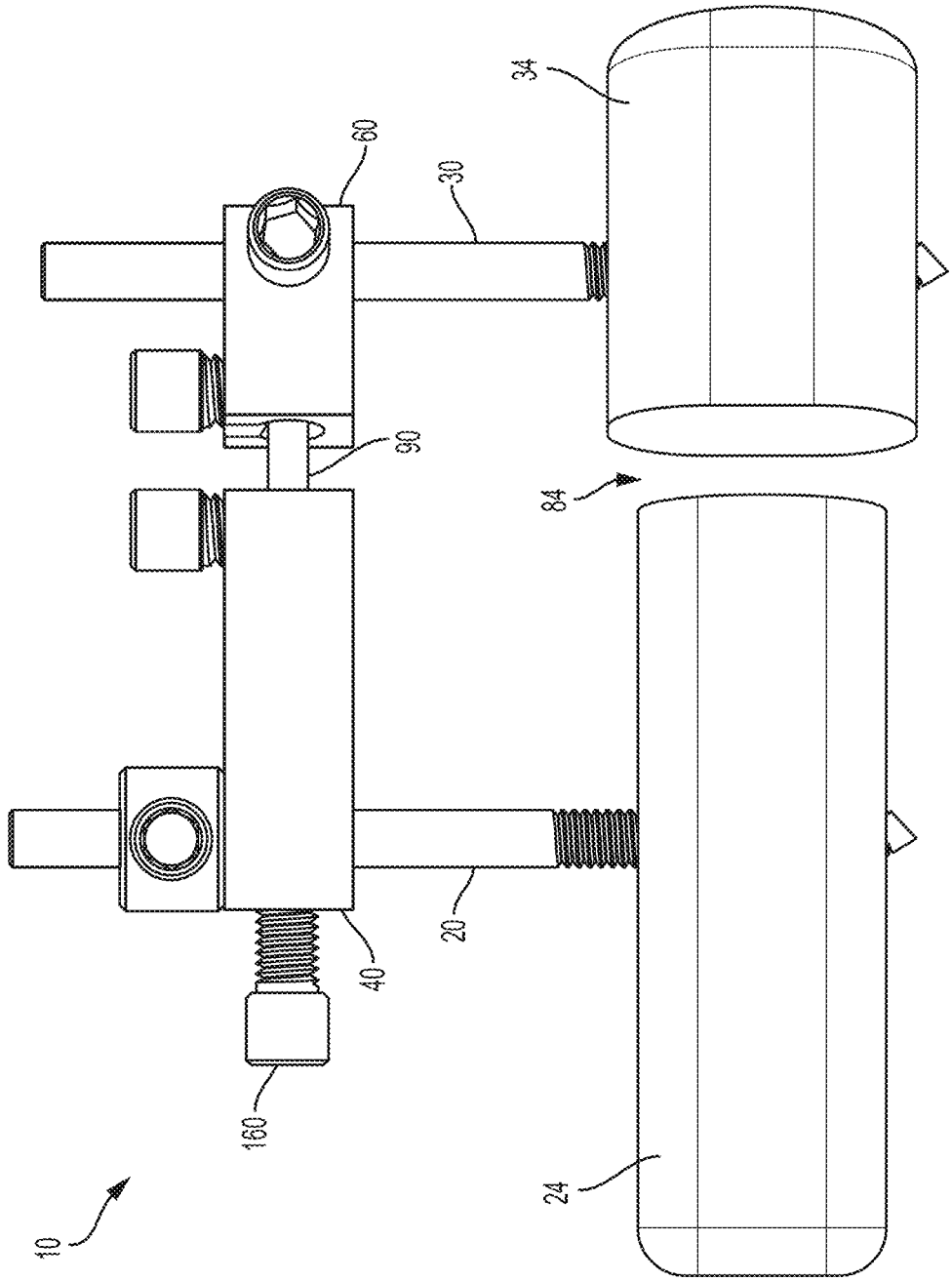

FIG. 7

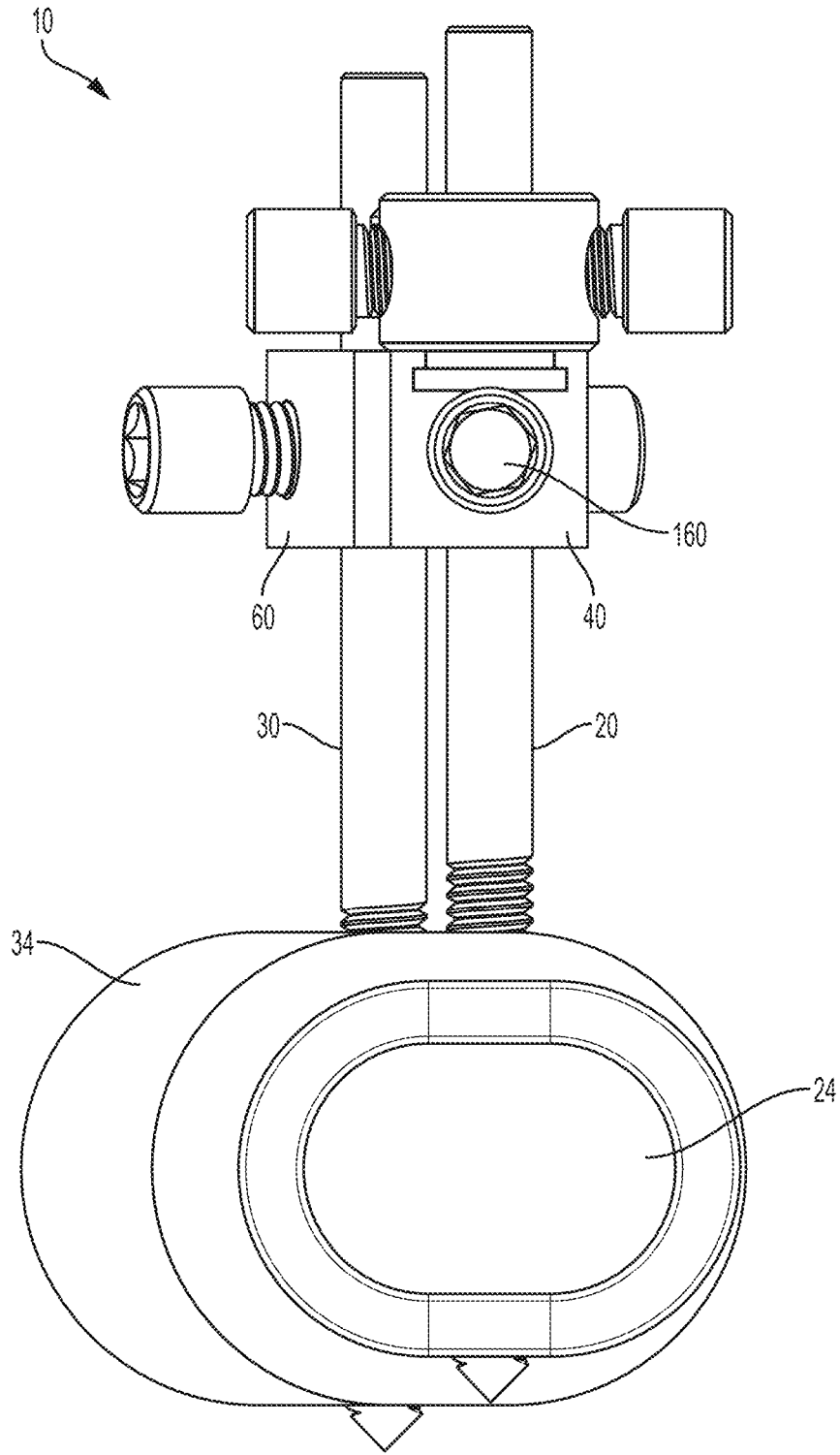

FIG. 8

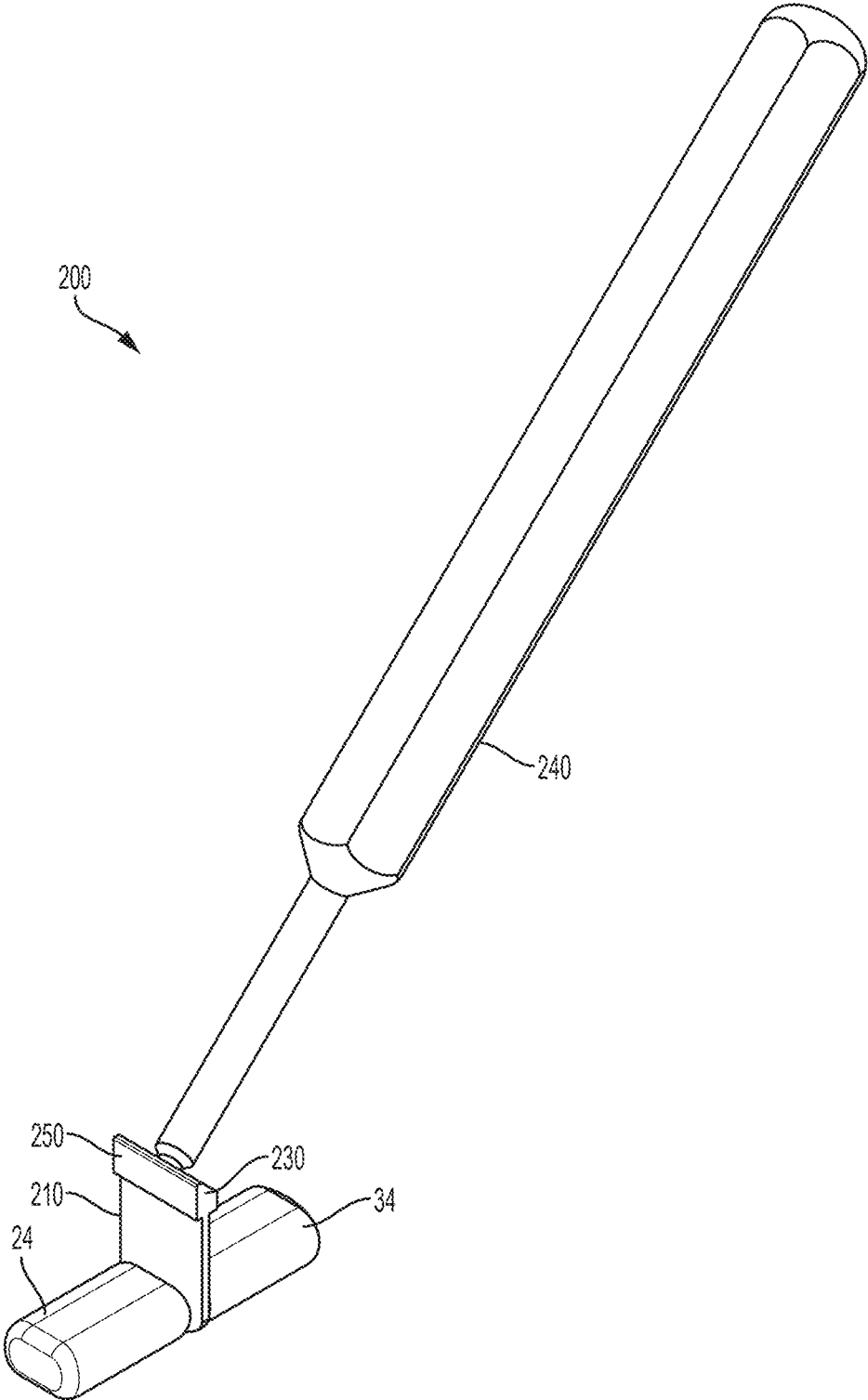

FIG. 9

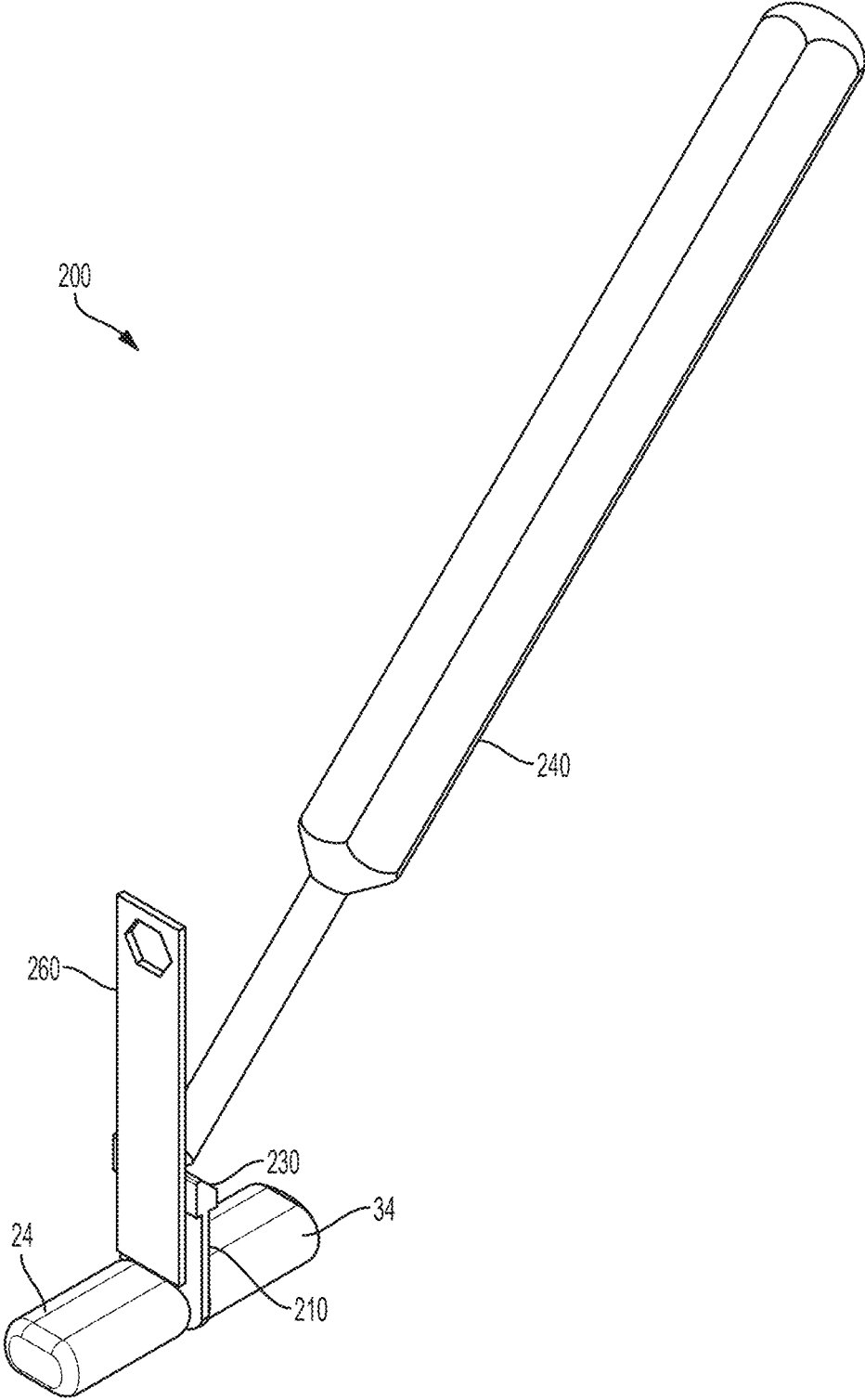

FIG. 10

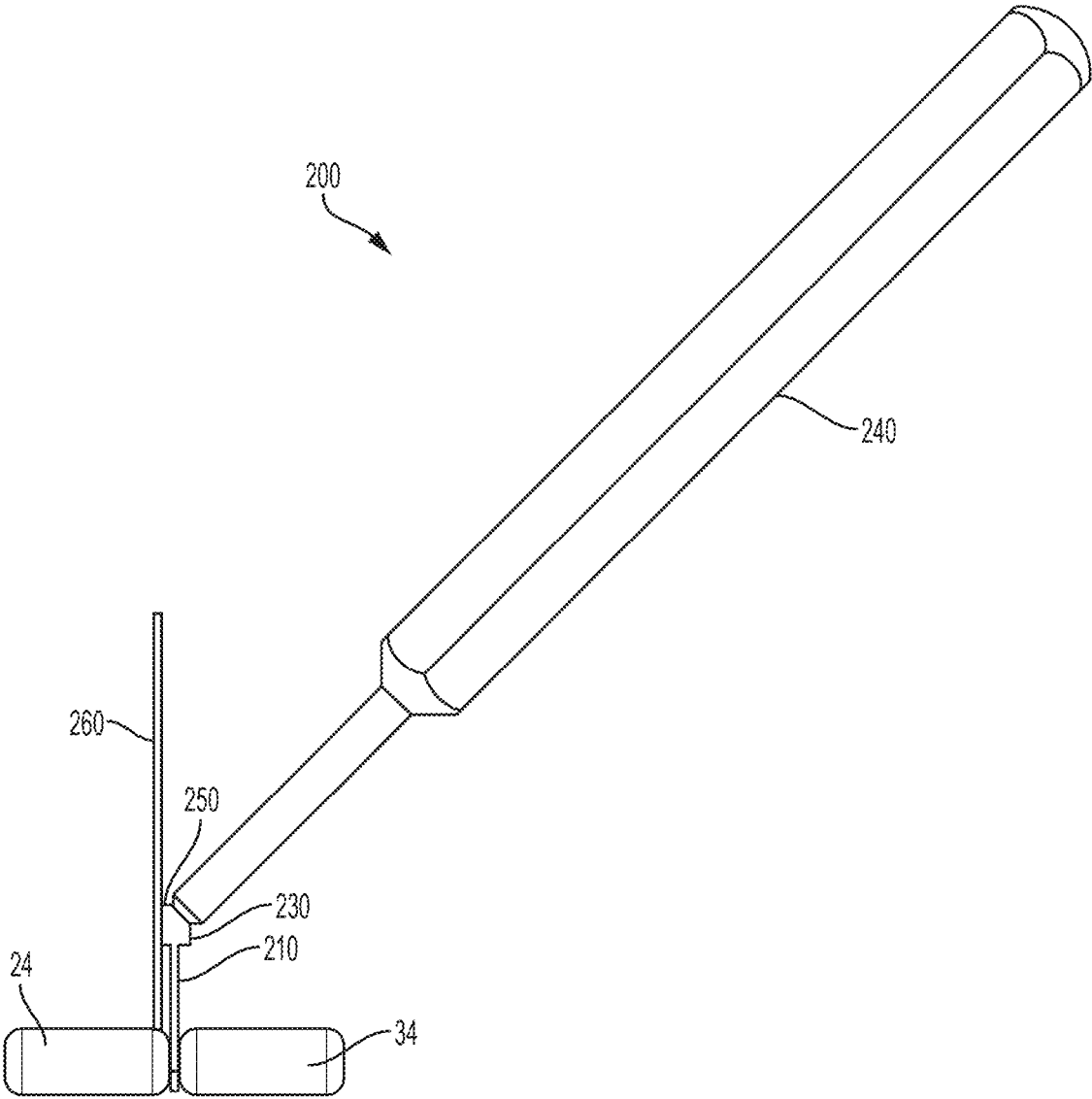

FIG. 11

BONE POSITIONING AND CUTTING SYSTEM AND METHOD

RELATED APPLICATIONS

This application is a continuation application of U.S. patent application Ser. No. 17/503,730, filed Oct. 18, 2021, which is a continuation application of U.S. patent application Ser. No. 17/201,008, filed Mar. 15, 2021, issued as U.S. Pat. No. 11,147,590, on Oct. 19, 2021, which is a continuation application of U.S. patent application Ser. No. 16/730,424, filed Dec. 30, 2019, issued as U.S. Pat. No. 10,945,764, on Mar. 16, 2021, which is a continuation application of U.S. patent application Ser. No. 15/894,702, filed Feb. 12, 2018, issued as U.S. Pat. No. 10,555,757, on Feb. 11, 2020, which is a divisional application of U.S. patent application Ser. No. 14/799,981, filed Jul. 15, 2015, which claims priority to U.S. Provisional Application No. 62/024,546, filed Jul. 15, 2014. The entire contents of each of these applications are hereby incorporated by reference.

TECHNICAL FIELD

This disclosure generally relates to devices and methods for positioning and cutting bones.

BACKGROUND

In various surgical procedures, it can be necessary to cut one or more bones. Success of such surgical procedures may often times be a function of the accuracy of the cut(s) being made to the one or more bones. Accomplishing accurate cuts can be especially complicated where surgical procedures involve cutting one or more bones that are relatively small as compared to bones in other locations of a surgical patient's anatomy. Exemplary surgical procedures involving cuts to one or more relatively small bones can include surgical procedures involving a foot or hand. To help facilitate accurate cuts to one or more bones, it may be useful to position the one or more bones to be cut in a manner that is conducive to a particular cut.

SUMMARY

One embodiment includes a bone positioning device. The embodiment of the bone positioning device can include at least one fixation pin for attachment to a first bone and at least one fixation pin for attachment to a second bone. A first block having at least one aperture can be included for slidably receiving a fixation pin(s), and a second block having at least one aperture can be included for slidably receiving a fixation pin(s). A multi-axis joint can connect the first block and the second block, where the multi-axis joint allows the first and second blocks to move with respect to each other about more than one axis.

Another embodiment includes a method for fixing an orientation of a first bone with respect to a second bone. The embodiment of the method can include attaching at least one fixation pin to a first bone and attaching at least one fixation pin to a second bone. At least one fixation pin can be inserted within a respective aperture of a first block, and at least one fixation pin can be inserted within a respective aperture of a second block. The first block can be positioned along and about the fixation pin(s) and a set screw(s) can be actuated to fix a position of the first block along and about the fixation pin(s), and similarly the second block can be positioned along and about the fixation pin(s) and a set screw(s) can be

actuated to fix a position of the second block along and about the fixation pin(s). The position of the first block can be adjusted with respect to the second block about at least a first axis and a second axis. A set screw can be actuated to fix a position about the first axis, and a set screw can be actuated to fix a position about the second axis.

A further embodiment includes a bone cutting guide. The embodiment of the bone cutting guide can include a plate defining a plane, a block having a guiding surface integral with or coupled to the plate, with the guiding surface being parallel to the plane and being spaced laterally therefrom. A handle can also be included extending from the plate.

BRIEF DESCRIPTION OF THE DRAWINGS

The following drawings are illustrative of particular embodiments of the present invention and therefore do not limit the scope of the invention. The drawings are not necessarily to scale (unless so stated) and are intended for use in conjunction with the explanations in the following detailed description. Embodiments of the invention will hereinafter be described in conjunction with the appended drawings, wherein like numerals denote like elements.

FIG. 1 is a perspective view of a bone positioning device according to an embodiment of the invention;

FIG. 2 is a top plan view of the bone positioning device of FIG. 1;

FIG. 3 is a side plan view of the bone positioning device of FIG. 1;

FIG. 4 is a perspective cross-sectional view of the bone positioning device of FIG. 1;

FIG. 5 is a perspective view of a bone positioning device attached to bones in a skewed position according to an embodiment of the invention;

FIG. 6 is a top view of the bone positioning device of FIG. 5;

FIG. 7 is a side view of the bone positioning device of FIG. 5;

FIG. 8 is a side view of the bone positioning device of FIG. 5;

FIG. 9 is a perspective view of a bone cutting guide according to an embodiment of the invention;

FIG. 10 is a perspective view of a bone cutting guide according to an embodiment of the invention in contact with a saw blade; and

FIG. 11 is a side plan view of the bone cutting guide and saw blade of FIG. 10.

DETAILED DESCRIPTION

The following detailed description is exemplary in nature and is not intended to limit the scope, applicability, or configuration of the invention in any way. Rather, the following description provides some practical illustrations for implementing exemplary embodiments of the present invention. Examples of constructions, materials, dimensions, and manufacturing processes are provided for selected elements, and all other elements employ that which is known to those of ordinary skill in the field of the invention. Those skilled in the art will recognize that many of the noted examples have a variety of suitable alternatives.

Embodiments of the invention include a bone positioning device. Embodiments of the bone positioning device can be useful for temporarily fixing bones in a desired position during a surgical procedure, such as a bone alignment, osteotomy, and/or fusion procedure. Such a procedure may be performed, for example, on bones (e.g., adjacent bones

3

separated by a joint or different portions of a single bone) in the foot or hand. In one example, the procedure can be performed to correct an alignment between a metatarsal (e.g. a first metatarsal) and a cuneiform (e.g., a first cuneiform), such as a bunion correction. An example of such a procedure is a Lapidus procedure. In another example, the procedure can be performed by modifying an alignment of a metatarsal (e.g. a first metatarsal). An example of such a procedure is a Basilar metatarsal osteotomy procedure.

As shown in FIGS. 1-4, the bone positioning device 10 can include at least one fixation pin, such as a first fixation pin 20, for attachment to a first bone 24. At least one fixation pin, such as a second fixation pin 30, can be provided for attachment to a second bone 34, such as an adjacent bone separated by a joint or different portions of a single bone. As shown best in FIG. 4, a first block 40 having a first aperture 50 can slidably receive the first fixation pin 20, and a second block 60 having a second aperture 70 can slidably receive the second fixation pin 30. The first and second apertures 50, 70 can allow the first and second blocks 40, 60 to slide along a longitudinal axis of the first and second fixation pins 20, 30, respectively. The first and second apertures 50, 70 can also allow the first and second blocks 40, 60 to rotate about the longitudinal axis of the first and second fixation pins 20, 30, respectively. In some embodiments, each of the first and second fixation pins 20, 30 are generally cylindrical and have a distal portion and a proximal portion, with the distal portion threaded for retention within the respective first or second bone, while the proximal portion is unthreaded for both sliding within the respective first or second aperture and free rotational movement within the respective first or second aperture. In some embodiments, the proximal portion has a uniform diameter, such that it does not contain a flared or "head" portion. In such embodiments, the first and second blocks can be positioned on the first and second fixation pins before or after the pins are engaged with bone.

Again as shown best in FIG. 4, a multi-axis joint 80 can be provided to connect the first block 40 and the second block 60 and located adjacent to a joint 84 between the first and second bones. In some embodiments, the multi-axis joint 80 allows the first block 40 and the second block 60 to move with respect to each other about more than one axis. In certain embodiments, the multi-axis joint 80 allows the first block 40 and the second block 60 to move with respect to each other about the three cardinal planes (i.e., X, Y, and Z axes). In the embodiment shown, the multi-axis joint 80 allows for angulation in all directions and rotation between the first and second blocks. FIGS. 5-8 depict an exemplary embodiment of the bone positioning device 10 attached to first and second bones 24, 34, where the first and second bones are skewed relative to each other. In this particular embodiment, a longitudinal axis of second bone 34 is skewed about 15 degrees relative to a longitudinal axis of first bone 24.

The multi-axis joint can include any suitable structure for allowing desired adjustments about more than one axis, such as desired adjustments about three axes. In some embodiments, with reference to FIG. 4, the multi-axis joint 80 includes a link 90 having a first end 94 rotatably connected to the first block 40 and a second end 98 rotatably connected to the second block 60. Such a multi-axis joint allows for the movement about the various axes discussed above at both the first end and the second end. In the embodiment shown, the first end 94 includes a first ball received within a first socket of the first block 40, and the second end 98 includes a second ball received within a second socket of the second block 60.

4

Some embodiments of the device allow the relative positions of the first and second bones to be fixed after a desired orientation has been achieved. For example, a first set screw 100 can extend through the first block 40 into the first aperture 50 and be positioned against the first fixation pin 20, for fixation of the first block on a longitudinal axis of the first fixation pin and/or about the longitudinal axis of the first fixation pin. Further, a second set screw 110 can extend through the second block 60 into the second aperture 70 and be positioned against the second fixation pin 30, for fixation of the second block on a longitudinal axis of the second fixation pin and/or about the longitudinal axis of the second fixation pin. In certain embodiments, the first and second set screws are positioned perpendicular to the first and second fixation pins. As shown in FIGS. 1-3, additional set screws 120, 130 extending through the first and second blocks can be positioned opposite of the first and second set screws, respectively. Such oppositely positioned set screws may facilitate use of the bone positioning device on a left foot or a right foot depending on a particular surgical procedure.

Set screws can also be provided to fix positions across the multi-axis joint. In the embodiment shown in FIG. 4, a first end set screw 140 extends through the first block 40 and is positioned against the first end 94 of the link 90. Further, a second end set screw 150 is shown extending through the second block 60 and positioned against the second end 98 of the link 90.

The set screws can include any structure suitable to fix the relative positions of the components described herein. In some embodiments, the set screws have a threaded connection with the blocks. Further, as shown, they can include a recess with a non-circular surface. Such a recess is useful for engagement with a driving tool, such as a hex-driver.

In some embodiments, the device can be used to apply a compression force between two adjacent bones, or different portions of a single bone, while the bones are held in desired alignment and/or to facilitate a desired alignment between the bones. Such a compression force is useful for certain surgical procedures, such as bone fusions. As shown in FIG. 4, in some embodiments the device 10 includes a compression screw 160 operable to exert a compression force between first and second bones 24, 34 connected to first and second fixation pins 20, 30, respectively. In the embodiment shown, the compression screw 160 is generally perpendicular to the fixation pins and is threadingly received within a block and positioned to act against one of the fixation pins.

One of the blocks can be adapted to allow for relative movement to exert the compression force. In the embodiment shown in FIG. 4, one of the blocks (e.g., the first block 40) has a first portion 170 slidably connected to second portion 180. An aperture (e.g., the first aperture 50) extends through the first portion and the second portion. In this embodiment, the first aperture has a first cross-sectional area in the first portion and a second cross-sectional area in the second portion, and the first cross-sectional area is smaller than the second cross-sectional area. The set screw 100 can extend through the first portion 170. The compression screw 160 can extend through the second portion 180. Upon actuation, the compression screw 160 will act against the fixation pin 20 and will pull the second portion 180 of the block 40 away from the fixation pin 20. The force will be transmitted through the multi-axis joint 80 through the other block 60 and fixation pin 30, thereby applying a compression force that tends to press together leading surfaces (e.g., interfacing surfaces) of the first and second bones 24, 34.

Some embodiments include a bone cutting guide. Such a guide can be useful for guiding the cutting of bone, such as

5

after a position of the bone has been fixed by the device described above. Bone cutting may be useful, for example, to facilitate contact between leading edges of adjacent bones or different portions of a single bone, such as in a bone alignment and/or fusion procedure.

An embodiment of a bone cutting guide is shown in FIGS. 9-11. In the embodiment shown, the guide **200** includes a plate **210** that defines a plane, a block **230**, and a handle **240** extending from the block **230**. As shown, the handle extends from the block **230** at an angle of between 30 and 60 degrees (e.g., 45 degrees) with respect to the plane. The plate **210** can include a top edge, a bottom edge opposite of the top edge, and first and second opposite side surfaces. In the embodiment shown in FIG. 9, the block **230** can include a surface **250** parallel to the plate **210** and offset from the plate by a distance (e.g., 1-20 millimeters). As shown in FIGS. 10 and 11, a cutting tool **260**, such as a saw blade, may be placed in apposition to the surface **250** to guide cutting in a plane parallel to the plate and offset from it by a distance (e.g., a distance the surface **250** if offset from the plate **210**).

In use, the bottom edge of the plate **210** can be placed such that it extends into a joint space or resected portion between the first bone **24** and a second bone **34**. The surface **250** can provide a cutting tool guide surface operable to guide a cutting tool to cut a leading edge of a bone in a plane parallel to the plate **210**.

Embodiments of the invention also include methods of temporarily fixing the orientation of a first bone with respect to a second bone, such as during a surgical procedure, using a bone positioning device. In some embodiments, the method includes a step of attaching a first fixation pin slidably and rotatably received within a first aperture of a first block to a first bone and attaching a second fixation pin slidably and rotatably received within a second aperture of a second block to a second bone. The method can also include the steps of positioning the first block along the first fixation pin and actuating a first set screw to fix a position of the first block along the first fixation pin. Likewise, the method can include the steps of positioning the second block along the second fixation pin and actuating a second set screw to fix a position of the second block along the second fixation pin. In some embodiments, the method can include the steps of adjusting the position of the first block with respect to the second block about at least a first axis and a second axis and actuating a third set screw to fix a position about the first axis and actuating a fourth set screw to fix a position about the second axis. In certain embodiments, the method can also include actuating a compression screw to apply a compression force between the first and second bones. It should be noted these steps need not be performed in the order stated, which is merely exemplary. For example, the second fixation pin may be attached to the second bone before the first fixation pin is attached to the first bone, both fixation pins may be attached before either block is adjusted or fixed, etc.

The method may also include steps following the fixing of the position of the bones. Some embodiments of the method also include imaging (e.g., with an X-ray) the first and second bones connected to the first and second blocks to confirm a desirable alignment. Certain embodiments of the method include fusing the first bone and the second bone, such as by attaching a bone connector (e.g., a plate, pin, screw, wire, or staple) to stably connect and fix the first bone and the second bone. Some embodiments also include the step of removing the first fixation pin from the first bone and

6

the second fixation pin from the second bone, such as at a time after the bones have been stabilized and connected with a bone connector.

Some embodiments of the method also include cutting a leading edge of the first or second bone using a cutting guide, such as by positioning a cutting guide proximate the bone (e.g., within a joint between adjacent bones or a resected portion of a single bone) and using the guide to cut a leading edge of the bone in a plane. Such embodiments can also include the step of actuating a compression screw to apply a compression force between the first and second bones after the cutting step.

Thus, embodiments of the invention are disclosed. Although the present invention has been described with reference to certain disclosed embodiments, the disclosed embodiments are presented for purposes of illustration and not limitation and other embodiments of the invention are possible. One skilled in the art will appreciate that various changes, adaptations, and modifications may be made without departing from the spirit of the invention.

What is claimed is:

1. A method of performing a bunion surgery to correct an alignment between a first metatarsal and a first cuneiform, the method comprising:

engaging a bone positioning device with a first metatarsal using a first fixation pin and with a first cuneiform using a second fixation pin, the bone positioning device extending across a joint separating the first metatarsal from the first cuneiform;

aligning a bone cutting guide with the joint between the first metatarsal and the first cuneiform, the bone cutting guide comprising a joint plate offset from a guide feature of the bone cutting guide, the joint plate extending downwardly relative to the guide feature, wherein aligning the bone cutting guide with the joint comprises inserting the joint plate into the joint;

using the guide feature of the bone cutting guide to guide a cutting tool to cut a leading edge of the first metatarsal;

using the bone positioning device to adjust an alignment of the first metatarsal in multiple planes to correct a bunion;

compressing the first metatarsal and the first cuneiform together; and

fixing a position of the first metatarsal relative to the first cuneiform with a bone connector.

2. The method of claim 1, further comprising, prior to fixing the position of the first metatarsal relative to the first cuneiform with the bone connector, temporarily fixing the position of the first metatarsal relative to the first cuneiform.

3. The method of claim 1, further comprising cutting a leading edge of the first cuneiform.

4. The method of claim 3, wherein cutting the leading edge of the first cuneiform comprises cutting the leading edge of the first cuneiform after using the bone positioning device to adjust the alignment of the first metatarsal.

5. The method of claim 3, wherein cutting the leading edge of the first cuneiform comprises using the guide feature of the bone cutting guide to guide the cutting tool to cut the leading edge of the first cuneiform.

6. The method of claim 1, further comprising, after fixing the position of the first metatarsal relative to the first cuneiform with the bone connector, removing the first fixation pin from the first metatarsal and removing the second fixation pin from the first cuneiform.

7. The method of claim 1, wherein the joint plate defines a plane, the guide feature defines a plane, and the plane defined by the joint plate is parallel to the plane defined by the guide feature.

8. The method of claim 7, wherein the bone cutting guide comprises a handle extending away from the joint plate at an angle between 30 degrees and 60 degrees with respect to the plane.

9. The method of claim 1, wherein the joint plate is offset from the guide feature by being spaced laterally from the guide feature, and the guide feature defines a guiding surface that is offset from the joint plate a distance ranging from 1 millimeter to 20 millimeters.

10. The method of claim 1, wherein the joint plate is integral with the guide feature.

11. The method of claim 1, wherein using the guide feature of the bone cutting guide to guide the cutting tool comprises placing the cutting tool in apposition to a guide surface defined by the guide feature of the bone cutting guide.

12. The method of claim 11, wherein the guide surface is operable to guide the cutting tool in a plane parallel to the guide surface.

13. The method of claim 1, wherein using the guide feature of the bone cutting guide to guide the cutting tool comprises placing the cutting tool in contact with a guide surface defined by the guide feature of the bone cutting guide.

14. The method of claim 1, wherein the cutting tool is a saw blade.

15. The method of claim 1, wherein the bone connector comprises one or more of a plate, a screw, and a pin.

16. The method of claim 1, wherein compressing the first metatarsal and the first cuneiform together comprises applying a force to press a first fixation pin inserted into the first metatarsal and a second fixation pin inserted into the first cuneiform toward one another.

17. The method of claim 1, wherein the bone positioning device comprises a sliding connection and a screw, and compressing the first metatarsal and the first cuneiform together comprises operating the screw.

18. A method of performing a bunion surgery to correct an alignment between a first metatarsal and a first cuneiform, the method comprising:

engaging a bone positioning device with a first metatarsal using a first fixation pin and with a first cuneiform using a second fixation pin, the bone positioning device extending across a joint separating the first metatarsal from the first cuneiform;

aligning a bone cutting guide with the joint between the first metatarsal and the first cuneiform, the bone cutting guide comprising a joint plate offset from a guide feature of the bone cutting guide, the joint plate extend-

ing downwardly relative to the guide feature, wherein aligning the bone cutting guide with the joint comprises inserting the joint plate into the joint;

using the guide feature of the bone cutting guide to guide a cutting tool to cut a leading edge of the first metatarsal;

using the bone positioning device to adjust an alignment of the first metatarsal in multiple planes to correct a bunion;

after using the bone positioning device to adjust the alignment of the first metatarsal in multiple planes to correct the bunion, cutting a leading edge of the first cuneiform;

compressing the first metatarsal and the first cuneiform together; and

fixing a position of the first metatarsal relative to the first cuneiform with a bone connector.

19. The method of claim 18, further comprising, prior to fixing the position of the first metatarsal relative to the first cuneiform with the bone connector, temporarily fixing the position of the first metatarsal relative to the first cuneiform.

20. The method of claim 18, further comprising, after fixing the position of the first metatarsal relative to the first cuneiform with the bone connector, removing the first fixation pin from the first metatarsal and removing the second fixation pin from the first cuneiform.

21. The method of claim 18, wherein cutting the leading edge of the first cuneiform comprises using the guide feature of the bone cutting guide to guide the cutting tool to cut the leading edge of the first cuneiform.

22. The method of claim 18, wherein the joint plate defines a plane, the guide feature defines a plane, and the plane defined by the joint plate is parallel to the plane defined by the guide feature.

23. The method of claim 22, wherein the bone cutting guide comprises a handle extending away from the joint plate at an angle.

24. The method of claim 18, wherein the guide surface is operable to guide the cutting tool in a plane parallel to the guide surface.

25. The method of claim 18, wherein the bone connector comprises one or more of a plate, a screw, and a pin.

26. The method of claim 18, wherein compressing the first metatarsal and the first cuneiform together comprises applying a force to press the first fixation pin inserted into the first metatarsal and the second fixation pin inserted into the first cuneiform toward one another.

27. The method of claim 18, wherein the bone positioning device comprises a sliding connection and a screw, and compressing the first metatarsal and the first cuneiform together comprises operating the screw.

* * * * *