

**European Telecommunications Standards Institute
AT-F Rapporteur Meeting
4 to 6 February 2003
Gothenburg**

Liaison Statement

From: ETSI TC AT-Features¹
To: 3GPP
Title: Work on MMS for PSTN/ISDN in AT-F
Date: 12 March 2003

Background

In continuation of the work on MMS for PSTN/ISDN in ETSI TC AT-F, during the AT-F meeting in February 2003 the MMS section of the Work Item DES/AT-030012 has been moved into the new Work Item

DES/AT-030023 "Access and Terminals (AT); Multimedia Message Service (MMS) for PSTN/ISDN; Multimedia Message Communication between a fixed network Multimedia Message Terminal Equipment and a Multimedia Message Service Centre"

A first draft of the document DES/AT-030023 was elaborated during the last weeks and will be discussed during the next AT#7 meeting on 07-11 April 2003.

Liaison

ETSI TC AT-Features would like to inform 3GPP about this work and kindly asks 3GPP to comment the attached first draft of DES/AT-030023.

~~~~~

---

<sup>1</sup> Contact: Chairman: Göran Engström // email: Goran.E.Engstrom@skanova.com  
Rapporteur: Werner Goertz // email: werner.goertz@bch.siemens.de

**Access and Terminals (AT);  
Multimedia Message Service (MMS) for PSTN/ISDN;  
Multimedia Message Communication between a  
fixed network Multimedia Message Terminal Equipment and a  
Multimedia Message Service Centre**

---



---

Reference

DES/AT-030023

---

Keywords

MMS, SMS, PSTN, ISDN

**ETSI**

650 Route des Lucioles

F-06921 Sophia Antipolis Cedex - FRANCE

---

Tel.: +33 4 92 94 42 00 Fax: +33 4 93 65 47 16

Siret N° 348 623 562 00017 - NAF 742 C

Association à but non lucratif enregistrée à la

Sous-Préfecture de Grasse (06) N° 7803/88

---

**Important notice**

Individual copies of the present document can be downloaded from:

<http://www.etsi.org>

The present document may be made available in more than one electronic version or in print. In any case of existing or perceived difference in contents between such versions, the reference version is the Portable Document Format (PDF). In case of dispute, the reference shall be the printing on ETSI printers of the PDF version kept on a specific network drive within ETSI Secretariat.

Users of the present document should be aware that the document may be subject to revision or change of status. Information on the current status of this and other ETSI documents is available at

<http://portal.etsi.org/tb/status/status.asp>

If you find errors in the present document, send your comment to:

[editor@etsi.fr](mailto:editor@etsi.fr)

---

**Copyright Notification**

No part may be reproduced except as authorized by written permission.  
The copyright and the foregoing restriction extend to reproduction in all media.

---

# Contents

|                                                                              |    |
|------------------------------------------------------------------------------|----|
| Intellectual Property Rights.....                                            | 4  |
| Foreword .....                                                               | 4  |
| Introduction .....                                                           | 4  |
| 1 Scope.....                                                                 | 5  |
| 2 References.....                                                            | 5  |
| 3 Definitions and abbreviations .....                                        | 6  |
| 3.1 Definitions .....                                                        | 6  |
| 3.2 Abbreviations.....                                                       | 6  |
| 4 Overview.....                                                              | 9  |
| 4.1 Fixed net MMS architecture .....                                         | 9  |
| 4.2 Interworking of fixed net MMSCs with other MMSCs .....                   | 9  |
| 4.3 MM transportation mechanism within fixed networks .....                  | 10 |
| 4.3.1 MM1 gateway structure.....                                             | 10 |
| 4.3.1 General transaction sequence .....                                     | 11 |
| 5 Basic transactions.....                                                    | 12 |
| 5.1 Submission of an MM.....                                                 | 12 |
| 5.2 Delivery of an MM .....                                                  | 12 |
| 5.2.1 MM Notification .....                                                  | 13 |
| 5.2.2 MM Retrieval .....                                                     | 13 |
| 5.3 MM Reporting .....                                                       | 14 |
| 5.3.1 MM Delivery Report.....                                                | 14 |
| 5.3.2 MM Read Report.....                                                    | 15 |
| 5.4 Additional procedures.....                                               | 16 |
| 6 Fixed net MMS protocol architecture .....                                  | 16 |
| 6.1 Protocol used for MM Notification, Delivery Report and Read Report ..... | 16 |
| 6.2 Protocol used for MM Submission and MM Retrieval .....                   | 17 |
| 6.2.1 Protocol stack .....                                                   | 17 |
| 6.2.1 Lower Layers.....                                                      | 17 |
| 6.2.2 PPP .....                                                              | 17 |
| 6.2.3 IP .....                                                               | 17 |
| 6.2.4 TCP .....                                                              | 18 |
| 6.2.5 HTTP.....                                                              | 18 |
| 6.2.6 MMS Communication.....                                                 | 18 |
| 6.2.7 MMS Application Services .....                                         | 18 |
| Annex A (informative).....                                                   | 19 |
| A.1 MM1 gateway structure in mobile networks.....                            | 19 |
| A.2 MM1 protocol stack used in mobile networks today .....                   | 19 |
| History.....                                                                 | 20 |

---

## Intellectual Property Rights

IPRs essential or potentially essential to the present document may have been declared to ETSI. The information pertaining to these essential IPRs, if any, is publicly available for **ETSI members and non-members**, and can be found in ETSI SR 000 314: "*Intellectual Property Rights (IPRs); Essential, or potentially Essential, IPRs notified to ETSI in respect of ETSI standards*", which is available from the ETSI Secretariat. Latest updates are available on the ETSI Web server (<http://webapp.etsi.org/IPR/home.asp>).

Pursuant to the ETSI IPR Policy, no investigation, including IPR searches, has been carried out by ETSI. No guarantee can be given as to the existence of other IPRs not referenced in ETSI SR 000 314 (or the updates on the ETSI Web server) which are, or may be, or may become, essential to the present document.

---

## Foreword

This ETSI Standard (ES) has been produced by ETSI Technical Committee Access and Terminals (AT).

---

## Introduction

The Short Messaging Service (SMS) has paved the way for a new approach to personal communication. Following the success in mobile telecommunication networks, SMS has also become in fixed line telecommunication networks a well-known feature. Based on ETSI standards, a continuously growing number of fixed line SMS capable terminals are installed and several SMS providers offer the possibility of exchanging Short Messages within and between fixed line and mobile telecommunication networks.

The Multimedia Messaging Service (MMS) in the mobile networks was created to provide a sophisticated kind of messaging which combines the advantages of both SMS and Email messaging. With MMS, the user is able to send and receive messages with a wide range of contents, e.g. text, images, audio- and video clips and even streaming contents. Similar to the Short Messaging Service (SMS), the Multimedia Messaging Service (MMS) is a non-real-time delivery system providing a store-and-forward mechanism. A good overview about the Multimedia Messaging Service can be found in [4] and [7].

The Multimedia Messaging Service for PSTN/ISDN follows the philosophy of adopting the existing Multimedia Message Service of the mobile networks as widely as possible, to

- simplify the interworking with the existing mobile net MMS;
- offer the same user experience for both fixed and mobile net users;
- reduce the fixed net MMS implementation efforts.

Following this philosophy, only the mobile network-specific transport mechanisms are replaced by transport mechanisms applicable to the fixed networks (PSTN/ISDN). The higher, not mobile network-specific MMS protocol layers are used similar to their respective use in mobile networks. Also the existing fixed net infrastructure can be used without modification.

---

## 1 Scope

The present document describes the MMS communication between a fixed net Multimedia Message Service Terminal Equipment and a Multimedia Message Service Centre using in-band signalling.

---

## 2 References

The following documents contain provisions which, through reference in this text, constitute provisions of the present document.

- References are either specific (identified by date of publication and/or edition number or version number) or non-specific.
- For a specific reference, subsequent revisions do not apply.
- For a non-specific reference, the latest version applies.

**Editor's note:** This list may contain several unreferenced documents and will be updated before document approval.

- [1] ETSI ES 201 986 V1.1.2 (2002-01): "Services and Protocols for Advanced Networks (SPAN); Short Message Service (SMS) for PSTN/ISDN; Service description".
- [2] ETSI ES 201 912 (V1.1.1): "Access and Terminals (AT); Short Message Service (SMS) for PSTN/ISDN; Short Message Communication between a fixed network Short Message Terminal Equipment and a Short Message Service Centre".
- [3] ETSI ES 202 060-1 "Short Message Service (SMS) for fixed networks; Network Based Solution (NBS); Part 1: Overview".
- [4] 3GPP TS 22.140 V5.2.0 (2002-06): "3rd Generation Partnership Project; Technical Specification Group Services and System Aspects; Multimedia Messaging Service (MMS); Stage 1 (Release 5)".
- [5] 3GPP TS 23.140 V5.3.0 (2002-06): "3rd Generation Partnership Project; Technical Specification Group Terminals; Multimedia Messaging Service (MMS); Functional description; Stage 2 (Release 5)".
- [6] 3GPP TR 23.039 V5.0.0 (2002-06): "3rd Generation Partnership Project; Technical Specification Group Terminals; Interface protocols for the connection of Short Message Service Centres (SMSCs) to Short Message Entities (SMEs) (Release 5)".
- [7] OMA-WAP-MMS-ARCH-v1\_1-20021101-C: "Multimedia Messaging Service; Architecture Overview; Version 1.1".
- [8] OMA-WAP-MMS-CTR-v1\_1-20021031-C: "Multimedia Messaging Service; Client Transactions; Version 1.1".
- [9] OMA-WAP-MMS-ENC-v1\_1-20021030-C: "Multimedia Messaging Service; Encapsulation Protocol; Version 1.1".
- [10] IETF; STD 0010 (RFC 2821): "Simple Mail Transfer Protocol".
- [11] ETSI EN 300 659-1 (V1.3.1): "Access and Terminals (AT); Analogue access to the Public Switched Telephone Network (PSTN); Subscriber line protocol over the local loop for display (and related) services; Part 1: On-hook data transmission".
- [12] ETSI EN 300 659-2 (V1.3.1): "Access and Terminals (AT); Analogue access to the Public Switched Telephone Network (PSTN); Subscriber line protocol over the local loop for display (and related) services; Part 2: Off-hook data transmission".

- [13] ETSI EN 300 659-3 (V1.3.1): "Access and Terminals (AT); Analogue access to the Public Switched Telephone Network (PSTN); Subscriber line protocol over the local loop for display (and related) services; Part 3: Data link message and parameter codings".
- [14] ETSI EN 300 403-1 (V1.3.2): "Integrated Services Digital Network (ISDN); Digital Subscriber Signalling System No. one (DSS1) protocol; Signalling network layer for circuit-mode basic call control; Part 1: Protocol specification [ITU-T Recommendation Q.931 (1993), modified]".

## 3 Definitions and abbreviations

### 3.1 Definitions

For the purposes of the present document, the following terms and definitions apply.

**MM1 Interface:** Interface between MMS Relay/Server and MMS User Agent

**MM2 Interface:** Interface between MMS Relay and MMS Server

**MM3 Interface:** Interface between MMS Relay/Server and External Servers / Messaging Systems.

**MM4 Interface:** Interface between MMS Relay/Server and Different MMSEs

**MM5 Interface:** Interface between MMS Relay/Server and HLR

**MM6 Interface:** Interface between MMS Relay/Server and MMS User Databases

**MM7 Interface:** Interface between MMS Relay/Server and MMS VAS Applications

**MM8 Interface:** Interface between MMS Relay/Server and Billing Systems

**MMS Relay/Server:** MMS-specific network entity/application that is under the control of an MMS service provider. An MMS Relay/Server transfers messages, provides operations of the MMS that are specific to or required by the mobile environment and provides (temporary and/or persistent) storage services to the MMS.

**MMS User Agent:** Application residing on a fixed net or mobile net terminal or an external device that performs MMS-specific operations on a user's behalf. An MMS User Agent is not considered part of an MMSE.

**MM Terminal Equipment:** A Terminal Equipment containing an MMS User Agent and an appropriate MMS user interface.

**MM Terminal:** See MM Terminal Equipment.

**Legacy Terminal:** A terminal which has no MMS User Agent and is therefore not able to send or receive Multimedia Messages.

### 3.2 Abbreviations

For the purposes of the present document, the following abbreviations apply:

**Editor's note:** This list may contain several unused abbreviations which will be deleted before document approval.

|       |                                           |
|-------|-------------------------------------------|
| 3GPP  | 3rd Generation Partnership Project        |
| APP   | APPLication                               |
| CCBS  | Completion of Calls to Busy Subscriber    |
| CLI   | Calling Line Identity                     |
| CLIP  | Calling Line Identification Presentation  |
| CM    | Connection Manager                        |
| Corba | Common Object Request Broker Architecture |
| DLC   | Data Link Control                         |
| DLL   | Data Link Layer                           |
| DSS1  | Digital Subscriber Signalling No 1        |

|        |                                                      |
|--------|------------------------------------------------------|
| DTMF   | Dual Tone Multi-Frequency                            |
| EMS    | Enhanced Messaging Service                           |
| F-MMS  | Fixed network MMS                                    |
| F-MMSC | Fixed network MMSC                                   |
| F-SMSC | Fixed network SMSC                                   |
| FSK    | Frequency Shift Keying                               |
| GSM    | Global System for Mobile communication               |
| HLR    | Home Location Register                               |
| HTTP   | Hypertext Transfer Protocol                          |
| IE     | Information Element                                  |
| IMAP   | Internet Message Access Protocol                     |
| IP     | Internet Protocol                                    |
| ISDN   | Integrated Services Digital Network                  |
| ISO    | International Standard Organization                  |
| ISUP   | ISDN User Part                                       |
| ITU    | International Telecommunication Union                |
| LSB    | Least Significant Bit                                |
| MAP    | Mobile Application Part                              |
| MM     | Multimedia Message                                   |
| MMS    | Multimedia Message Service                           |
| MMSC   | Multimedia Message Service Center                    |
| MMSE   | Multimedia Messaging Service Environment             |
| MMTE   | Multimedia Messaging Terminal Equipment              |
| MMTE-D | Multimedia Messaging Terminal Equipment, Destination |
| MMTE-O | Multimedia Messaging Terminal Equipment, Originator  |
| MS     | Mobile Station                                       |
| MSB    | Most Significant Bit                                 |
| MWI    | Message Waiting Indication                           |
| OSI    | Open System Interface                                |
| PABX   | Private Automatic Branch eXchange                    |
| PAP    | Password Authentication Protocol                     |
| PIN    | Personal Identification Number                       |
| PL     | Presentation Layer                                   |
| PLMN   | Public Land Mobile Network                           |
| POP    | Post Office Protocol                                 |
| PPG    | Push Proxy Gateway                                   |
| PPP    | Point to Point Protocol                              |
| PSTN   | Public Switched Telephone Network                    |
| RAS    | Remote Access Server                                 |
| REQ    | Request                                              |
| RES    | Result                                               |
| RL     | Relay Layer                                          |
| SIM    | Subscriber Identification Module                     |
| SM     | Short Message(s)                                     |
| SMAL   | Short Message Application Layer                      |
| SMSC   | Short Message Service Centre                         |
| SMTE   | Short Message Terminal Equipment                     |
| SMTE-O | Short Message Terminal Equipment Originated          |
| SMTE-T | Short Message Terminal Equipment Terminated          |
| SMTL   | Short Message Transfer Layer                         |
| SME    | Short Message Entity                                 |
| SME-M  | Short Message Entity Master                          |
| SME-S  | Short Message Entity Slave                           |
| SMS    | Short Message Service                                |
| SMSC   | Short Message Service Centre                         |
| SMTP   | Simple Mail Transfer Protocol                        |
| SOAP   | Simple Object Access Protocol                        |
| SS7    | Signalling System No. 7                              |
| TBD    | To Be Determined                                     |
| TCP    | Transmission Control Protocol                        |
| TL     | Transfer Layer                                       |
| TP-FCS | Transfer Protocol - Failure Cause                    |

|        |                                           |
|--------|-------------------------------------------|
| UBS    | User Based Solution                       |
| UBS1   | User Based Solution, Protocol 1           |
| UBS2   | User Based Solution, Protocol 2           |
| UE     | User Equipment                            |
| UMTS   | Universal Mobile Telecommunication System |
| VAS    | Value Added Service                       |
| WAP    | Wireless Application Protocol             |
| WP TCP | Wireless Profiled TCP                     |
| WSP    | Wireless Session Protocol                 |
| XML    | eXtensible Markup Language                |

## 4 Overview

### 4.1 Fixed net MMS architecture

The fixed net MMS architecture is equal to the mobile net MMS architecture. The following figure, taken from 3GPP TS 23.140 [5], gives an overview about the general MMS architecture applicable to both the mobile net MMS and the fixed line MMS.

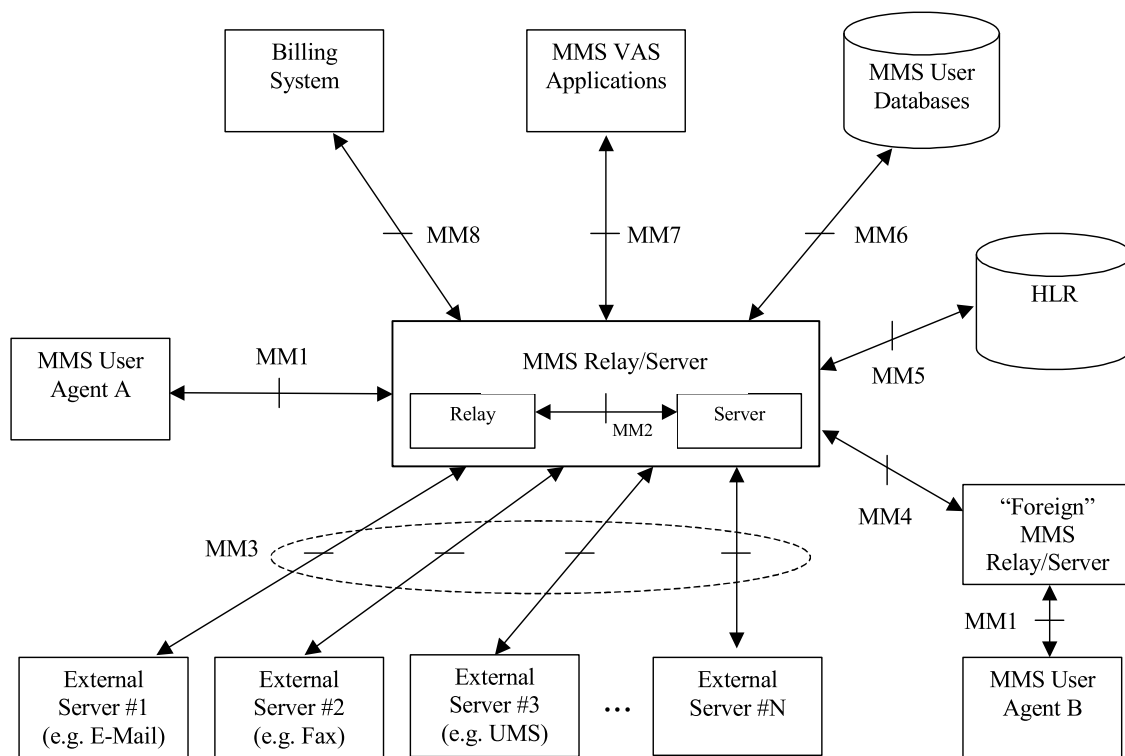

**Figure 1: MMS Reference Architecture**

A description of the interfaces MM1..MM8 can be found in 3GPP TS 23.140 [5]

### 4.2 Interworking of fixed net MMSCs with other MMSCs

The following figure, based on the respective figure in 3GPP TS 23.140 [5], gives an overview about the interworking between fixed net and mobile net MMSCs. As defined in 3GPP TS 23.140 [5], the interworking between the MMS Relay/Servers shall be based on SMTP according to STD 10 (RFC 821) [10].

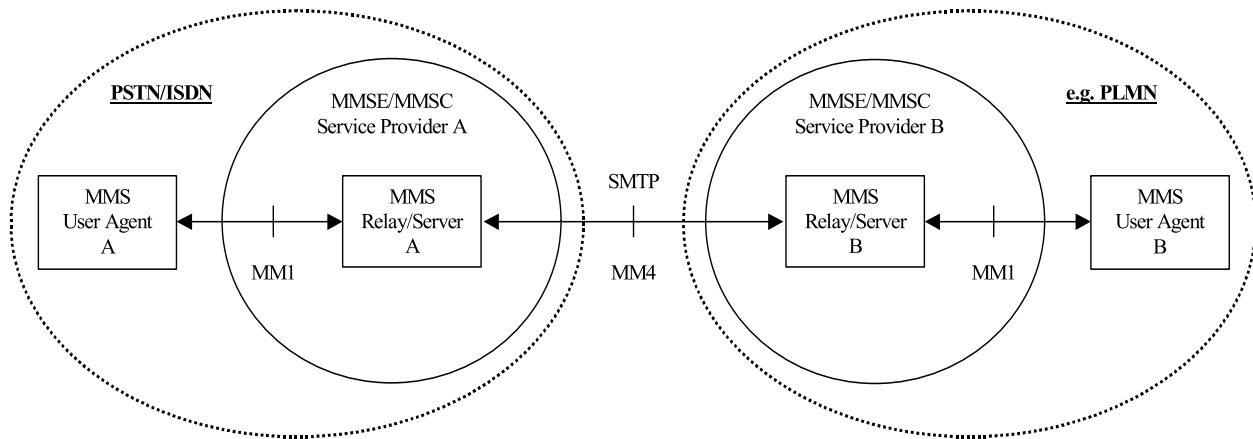

Figure 2: Interworking of fixed net MMSCs with other MMSCs

### 4.3 MM transportation mechanism within fixed networks

The relevant interface for the provision of MMS in the fixed net (PSTN/ISDN) is the MM1, which is the interface between the MMS Relay/Server and the MMS User Agent.

#### 4.3.1 MM1 gateway structure

The MM1 gateway structure for fixed networks is depicted in figure 3 below. It is similar to the respective MM1 gateway structure used in mobile networks (cf. figure 11 in clause A.1). The main difference between the fixed net MM1 gateway structure and the mobile net gateway structure is the use of two different communication paths between the fixed net MMS gateway and the fixed net MMS terminal.

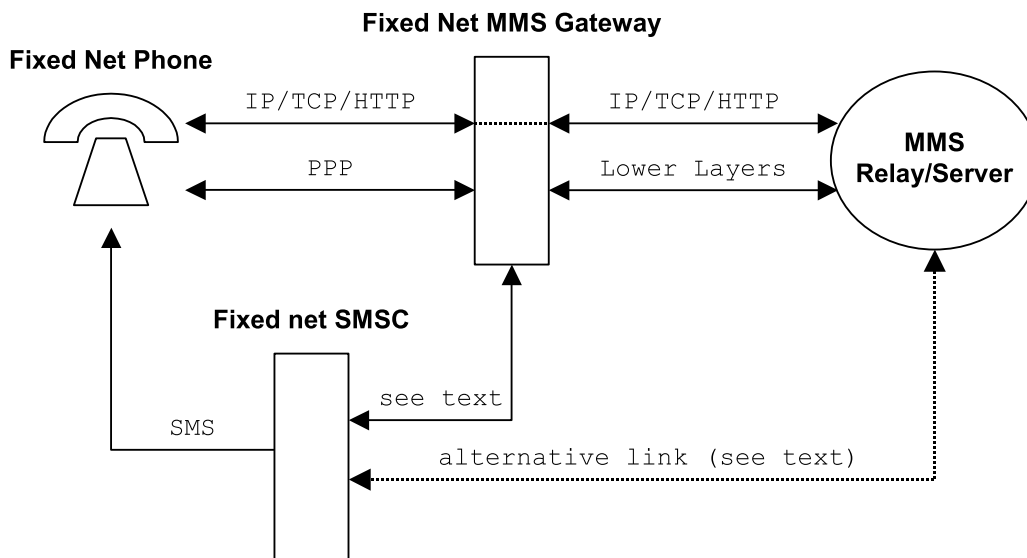

Figure 3: MM1 gateway structure for fixed networks

The interface between fixed net SMSC and fixed net MMS gateway (or MMS Relay/Server respectively) can be based on several different SMSC access protocols as defined in 3GPP TR 23.039 [6].

One of these communication paths is the fixed net Short Message Service (SMS). This service provides the push-functionality required for the transmission of MM Notification, MM Delivery Report and MM Read Report. The fixed net SMSC may be requested by the MMS Relay/Server or the fixed net MMS gateway to send out the respective information to the fixed net terminal.

NOTE: Other bearers for MM Notification, MM Delivery Report and MM Read Report, e.g. MWI, are for further study.

The other communication path used for MMS in fixed networks is an HTTP/TCP/IP connection. Using this connection, the MM Submission and MM Retrieval transactions are handled.

### 4.3.1 General transaction sequence

Figure 4 describes the general sequence of transactions to send an MM from an originating fixed net MM terminal (MMTE-O) to a destination fixed net MM terminal (MMTE-D). There are five basic transactions:

1. "MM Submission" the originating MM terminal submits an MM to the MMSE
2. "MM Notification" the destination MM terminal is notified of the presence of a new MM
3. "MM Retrieval" the destination MM terminal retrieves the new MM
4. "MM Delivery Report" the originating MM terminal is notified of the delivery of the submitted MM
5. "MM Read Report" the originating MM terminal is notified that the MM was read by the recipient

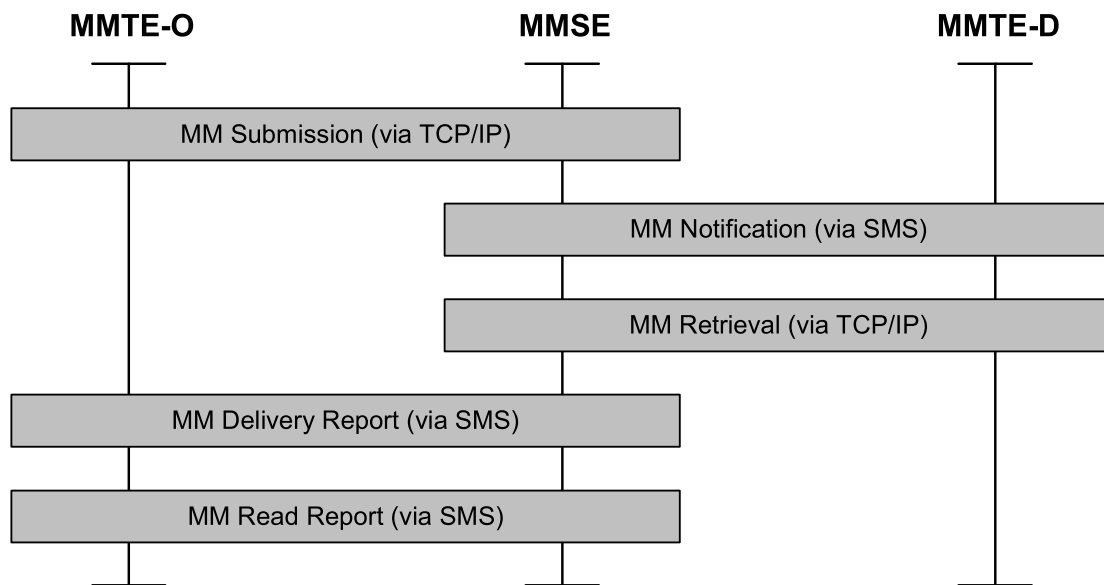

**Figure 4: Generalized MMS transaction sequence in fixed networks**

The transactions MM Notification, MM Delivery Report and MM Read Report are performed via SMS for PSTN/ISDN. The MM Notification is a mandatory transaction, while the MM Delivery Report and the MM Read Report are only performed if requested by the originator and permitted by the recipient.

NOTE: Other bearers for MM Notification, MM Delivery Report and MM Read Report, e.g. MWI, are for further study.

The transactions MM Submission and MM Retrieval are performed via HTTP/TCP/IP.

NOTE1: Other access methods between the MMS Relay/Server and the MMS User Agent are for further study (e.g. DSL).

NOTE2: Other possibilities for MM Retrieval, e.g. via Internet, are for further study.

## 5 Basic transactions

### 5.1 Submission of an MM

To send an MM from a fixed net MMS terminal, the fixed net MMS terminal connects to the MMS Relay/Server using internet protocol mechanisms (HTTP/TCP/IP) to transmit the MMS to the F-MMS Relay/Server. The connection between the fixed net MMS terminal and the MMS Relay/Server is handled via a fixed net MMS gateway as shown in figure 3. The fixed net MMS gateway provides the RAS dial-in functionality required by the terminal to establish the HTTP/TCP/IP connection. After the submission of the MM from the terminal to the Relay/Server has been finished, the connection is released. Figure 5 below describes the abstract message flow for the submission of an MM. The abstract protocol message MM1\_submit.REQ carries the content of the Multimedia Message as well as information like the recipient address, a transaction ID, etc. The abstract protocol message MM1\_submit.RES carries the response of the MMSE to the respective MM1\_submit.REQ. More basic information about these abstract protocol messages can be found in 3GPP TS 23.140 [5].

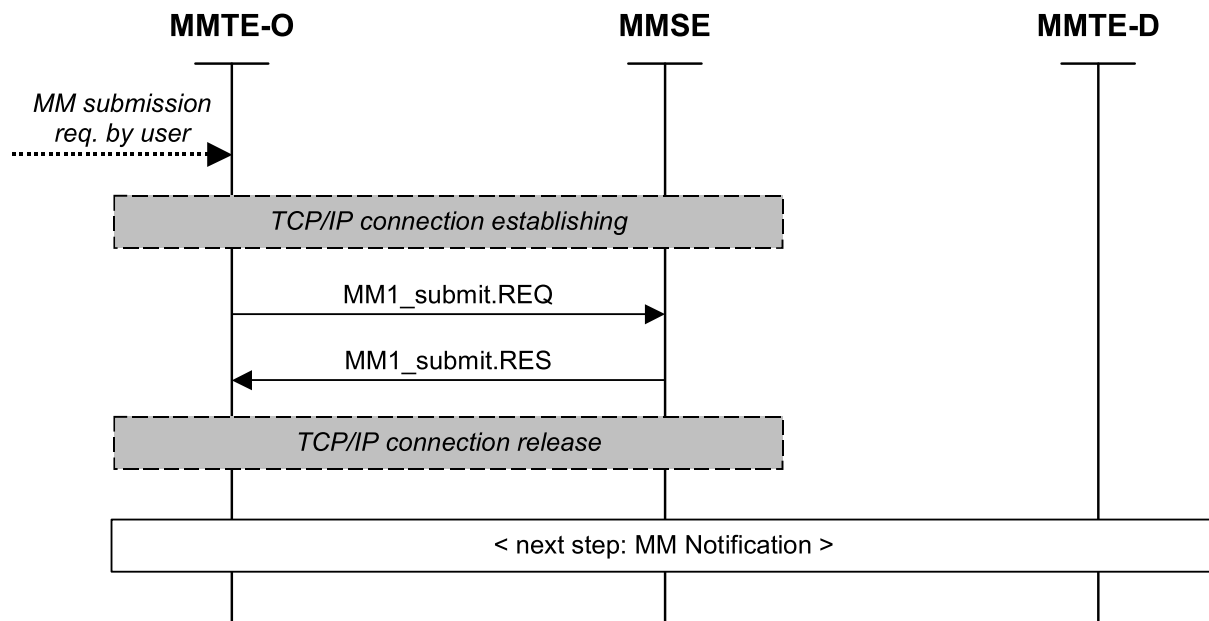

**Figure 5: Example abstract message flow for MM Submission**

After the MM has been received by the MMS Relay/Server, the Relay/Server forwards the MMS to the next entity involved in the delivery chain to the destination. The next involved entity may be another Relay/Server system or another messaging system. The final destination may be a fixed net MMS terminal or any other destination, e.g. a mobile net MMS terminal.

### 5.2 Delivery of an MM

Different from the procedures known from SMS, the delivery of an MM is split up into two separate procedures, the MM Notification and the MM Retrieval.

In the first step, according to [5], an MM Notification is sent to the recipient of an MM by the MMS Relay/Server, which notifies the recipient of a new MM being ready for retrieval. The MM Notification can contain various information about the stored MMS, like the sender's address, subject of the message, message size, message expiry, content location etc.

In the second step, after the MM Notification has been received by the MMS terminal, the terminal retrieves the respective MM from the MMSC.

## 5.2.1 MM Notification

The MM Notification is transmitted to the destination terminal using the fixed net Short Message Service defined by ES 201 986 [1] and ES 201 912 [2] (UBS1 and UBS2) and ES 202060 [3] (NBS).

Figure 6 below describes the abstract message flow for the transmission of an MM Notification to the destination terminal. The abstract protocol message MM1\_notification.REQ carries a message reference, i.e. an indication of the location of the content of the respective new MM being ready for retrieval, as well as information about this MM like message size, time of expiry, etc. More basic information about this abstract protocol message can be found in 3GPP TS 23.140 [5].

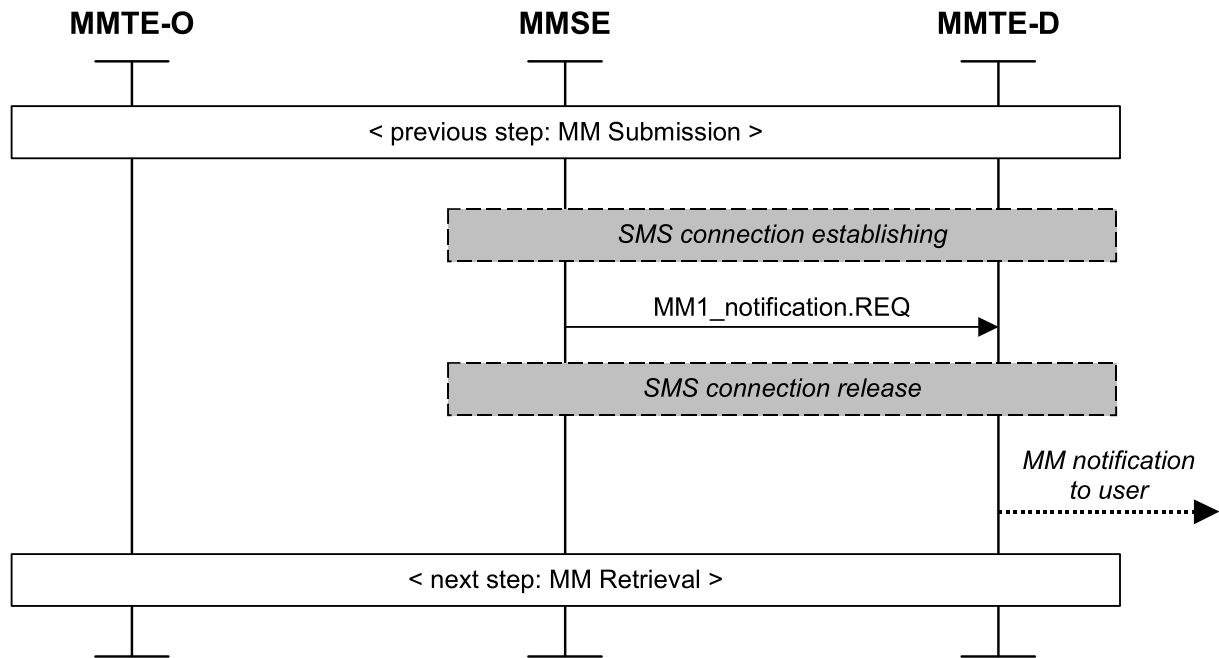

**Figure 6: Example abstract message flow for MM Notification**

## 5.2.2 MM Retrieval

After the MM Notification has been received by the MMS terminal, the terminal may connect to the F-MMSC to download the respective MM. The MM Retrieve procedure may be either initiated automatically by the terminal or manually by the user.

Figure 9 below describes the abstract message flow for the retrieval of an MM by the destination terminal.

The abstract protocol message MM1\_notification.RES carries the response of the receiving terminal to the respective MM1\_notification.REQ (see clause 5.2.1).

The abstract protocol message MM1\_retrieve.REQ carries the message reference, i.e. an indication of the location of the content of the MM to be retrieved. As a response to the MM1\_retrieve.REQ, the abstract protocol message MM1\_notification.RES carries the content of the Multimedia Message as well as information like date and time, content type, a message ID, etc.

Finally, the abstract protocol message MM1\_acknowledgement.REQ carries a request of the receiver to allow or disallow the sending of an MM Delivery Report to the MM originator. More basic information about these abstract protocol messages can be found in 3GPP TS 23.140 [5].

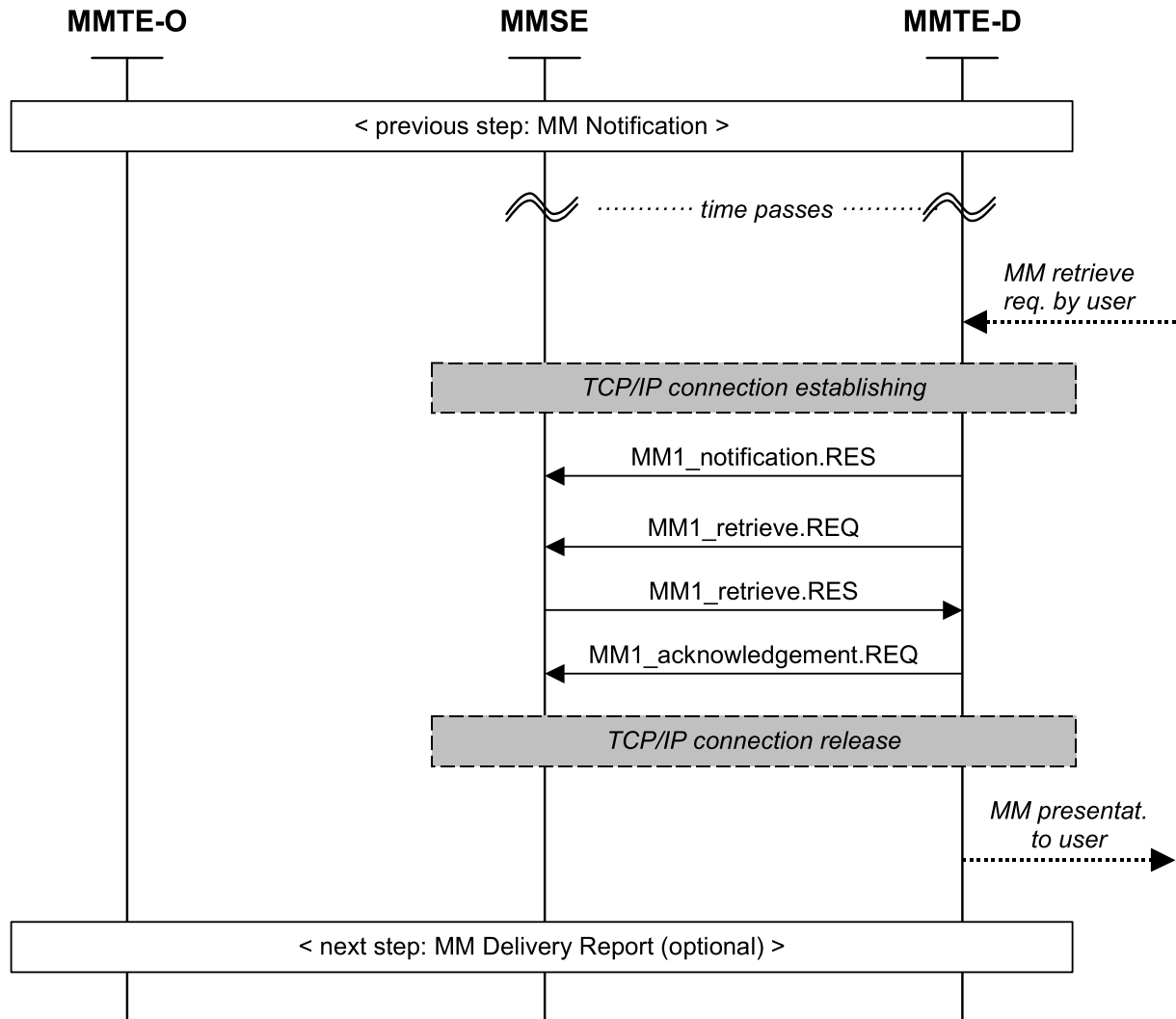

Figure 7: Example abstract message flow for MM Retrieval

## 5.3 MM Reporting

### 5.3.1 MM Delivery Report

If requested by the originator and permitted by the recipient, an MM Delivery Report according to 3GPP TS 23.140 [5] may be sent back to the originator of the MMS after the MMS has been transferred to the final destination terminal.

The MM Delivery Report is transmitted to the originating terminal using the fixed net Short Message Service defined by ES 201 986 [1] and ES 201 912 [2] (UBS1 and UBS2) and ES 202060 [3] (NBS).

Figure 8 below describes the abstract message flow for the transmission of an MM Delivery Report to the originating terminal. The abstract protocol message MM1\_delivery\_report.REQ carries information about the status of a previously submitted MM (e.g. retrieved, forwarded, expired, rejected) as well as information like date and time, a message ID, etc. More basic information about this abstract protocol message can be found in 3GPP TS 23.140 [5].

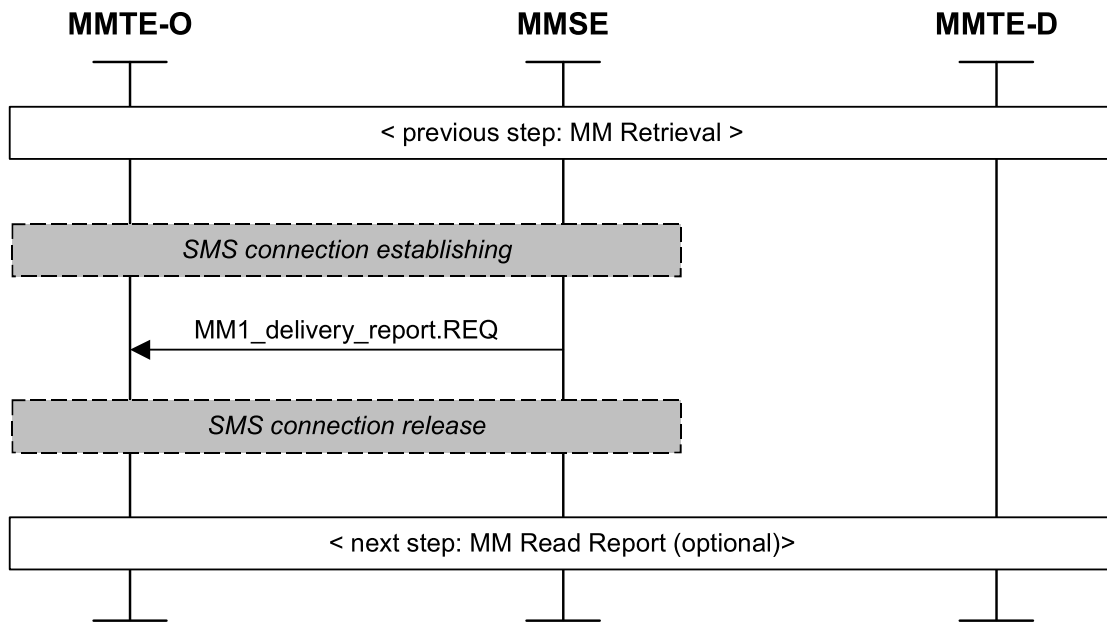

**Figure 8: Example abstract message flow for MM Delivery Report**

### 5.3.2 MM Read Report

If requested by the originator and permitted by the recipient, also an MM Read Report according to 3GPP TS 23.140 [5] may be sent back to the originator of the MMS after the MMS has been read by the recipient.

The MM Read Report is transmitted to the originating terminal using the fixed net Short Message Service defined by ES 201 986 [1] and ES 201 912 [2] (UBS1 and UBS2) and ES 202060 [3] (NBS).

Figure 9 below describes the abstract message flow for the transmission of an MM Read Report from the destination terminal via the MMSE to the originating terminal. The abstract protocol message `MM1_read_reply_receptient.REQ` carries information about the read status a previously submitted MM (e.g. read, deleted without being read) as well as information like date and time, a message ID, etc from the destination terminal to the MMSE. The abstract protocol message `MM1_read_reply_originator.REQ` carries that information from the MMSE to the originator. More basic information about these abstract protocol messages can be found in 3GPP TS 23.140 [5].

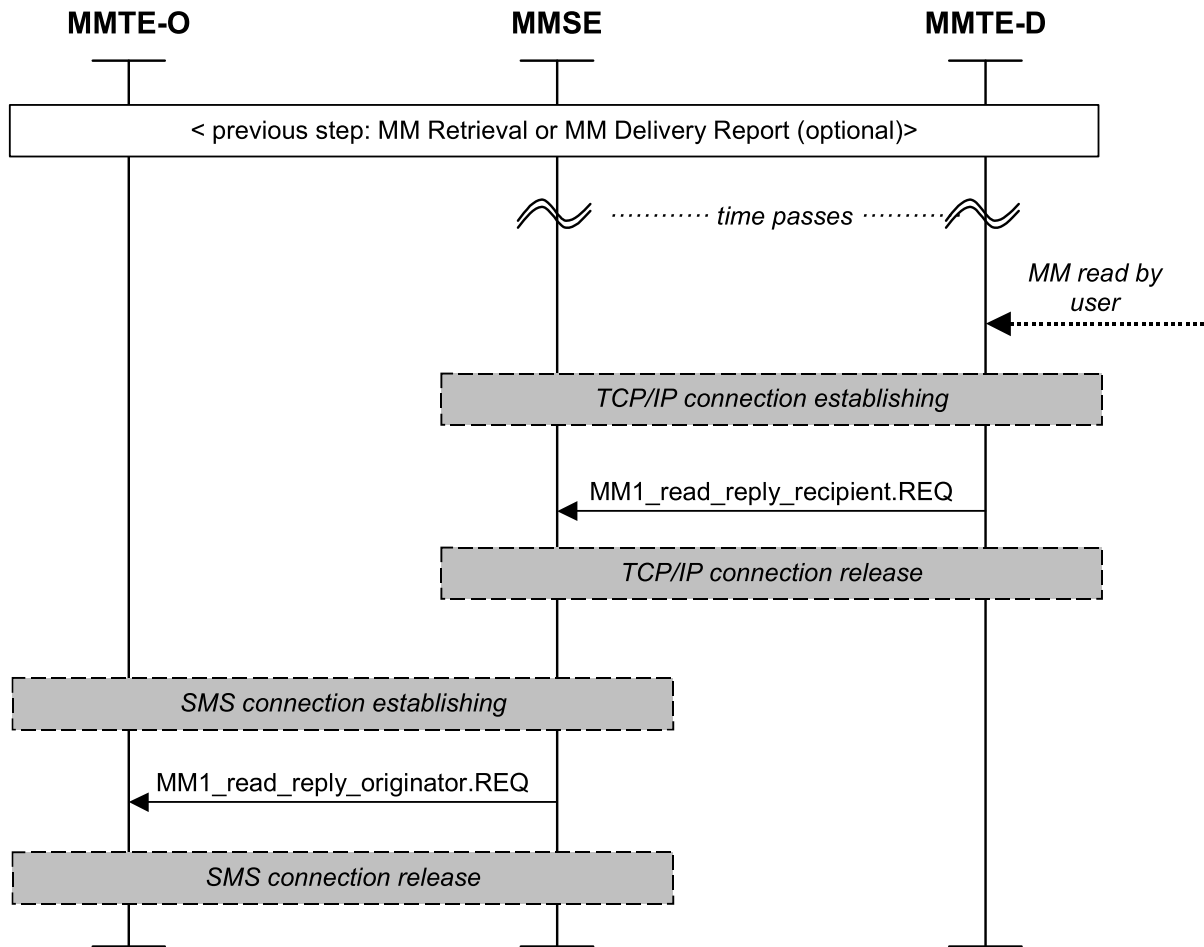

Figure 9: Example abstract message flow for MM Read Report

## 5.4 Additional procedures

Editor's note: Further procedures like the negotiation of the terminal's capabilities are for further study.

# 6 Fixed net MMS protocol architecture

## 6.1 Protocol used for MM Notification, Delivery Report and Read Report

The transactions MM Notification, MM Delivery Report and MM Read Report are handled using the fixed net Short Message Service defined by ES 201 986 [1] and ES 201 912 [2] (UBS1 and UBS2) and ES 202060 [3] (NBS).

The contents of the MM Notification are for further study. There are in principle two possibilities.

- In case of MMS Terminals, the F-MMS Relay/Server sends a binary-coded MM Notification using SMS.
- In case of Legacy Terminals, the F-MMS Relay/Server sends an informative notification via SMS (e.g. a plain text message like "You have received a new multimedia message"). The receiving user may use this information to retrieve the respective MM e.g. via a PC connected to the internet.

NOTE: Other bearers for MM Notification, MM Delivery Report and MM Read Report, e.g. MWI, are for further study.

## 6.2 Protocol used for MM Submission and MM Retrieval

The transactions MM Submission and MM Retrieval are performed via HTTP/TCP/IP.

### 6.2.1 Protocol stack

The MM1 protocol stack for MM Submission and MM Retrieval in the fixed net is described in figure 10. The structure of this protocol stack is very similar to the MM1 protocol stack used in mobile networks today (see figure 12 in Annex A.2), except the use of HTTP/TCP/IP instead of WAP protocol layers between the fixed net MMS User Agent and the fixed net MMS gateway. Therefore, the use of a WAP gateway is not necessary in the fixed network.

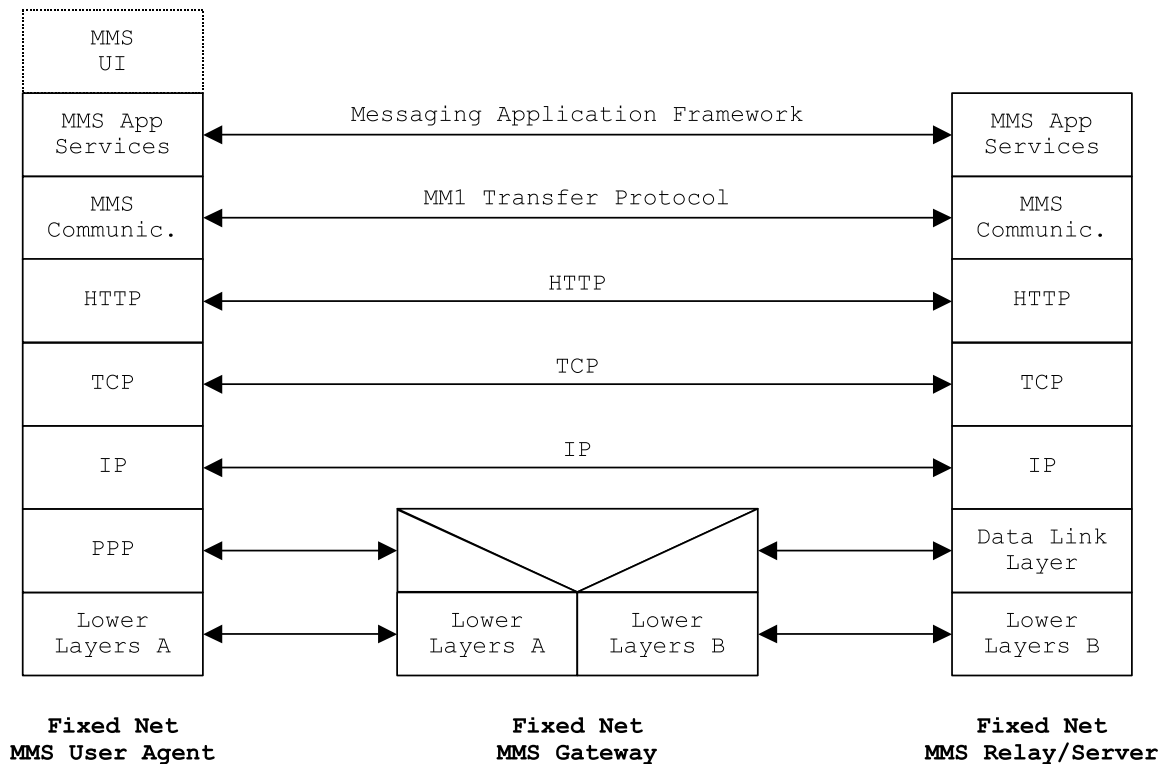

**Figure 10: MM1 protocol layers for MM Submission and MM Retrieval in fixed networks**

The functionality as it is provided by a WAP gateway in mobile networks is in the fixed network performed by an even simpler fixed net MMS gateway. This fixed net MMS gateway just provides low-level transport mechanisms and RAS functionalities for the fixed net MMS User Agent and lower layer communication services for the MMS Relay/Server. The interface between fixed net MMS gateway and MMS Relay/Server remains the same as between the WAP gateway and the MMS Relay/Server in mobile networks.

NOTE: The possibility to use other transportation mechanisms and modem protocols like a modified FAX protocol etc. is for further study.

### 6.2.1 Lower Layers

*For further study.*

### 6.2.2 PPP

*For further study.*

### 6.2.3 IP

*For further study.*

## 6.2.4 TCP

*For further study.*

## 6.2.5 HTTP

*For further study.*

## 6.2.6 MMS Communication

*For further study.*

## 6.2.7 MMS Application Services

*For further study.*

## Annex A (informative)

### A.1 MM1 gateway structure in mobile networks

The figure below gives a rough overview about the MM1 gateway structure in mobile networks today. The communication, between mobile net MMS Relay/Server and mobile net MMS User Agent is handled via a WAP gateway. For details, see clause A.2 below.

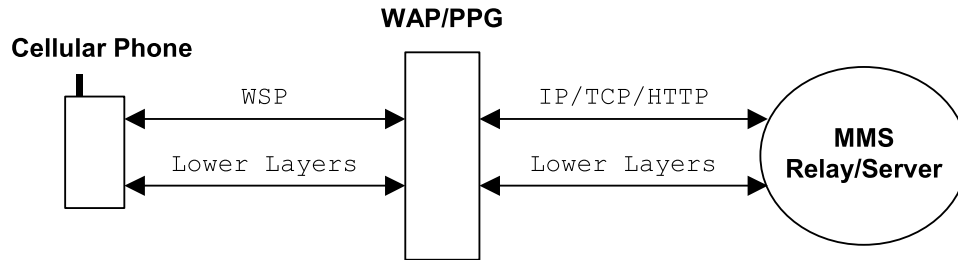

Figure 11: MM1 gateway structure in mobile networks

### A.2 MM1 protocol stack used in mobile networks today

The diagram below describes the protocol stack used in mobile networks today. The communication between mobile net MMS Relay/Server and mobile net MMS User Agent is handled via a WAP gateway. The WAP gateway is connected to the MMS Relay/Server using HTTP/TCP/IP and to the mobile net MMS User Agent using the appropriate WAP protocols (WAP WSP etc.).

The WAP gateway provides a conversion between the transport mechanisms used on the MMS Relay/Server side (HTTP/TCP/IP) and the transport mechanisms used on the mobile net MMS User Agent side (WAP WSP etc.). The payload, i.e. the MMS specific content of the communication, remains unchanged.

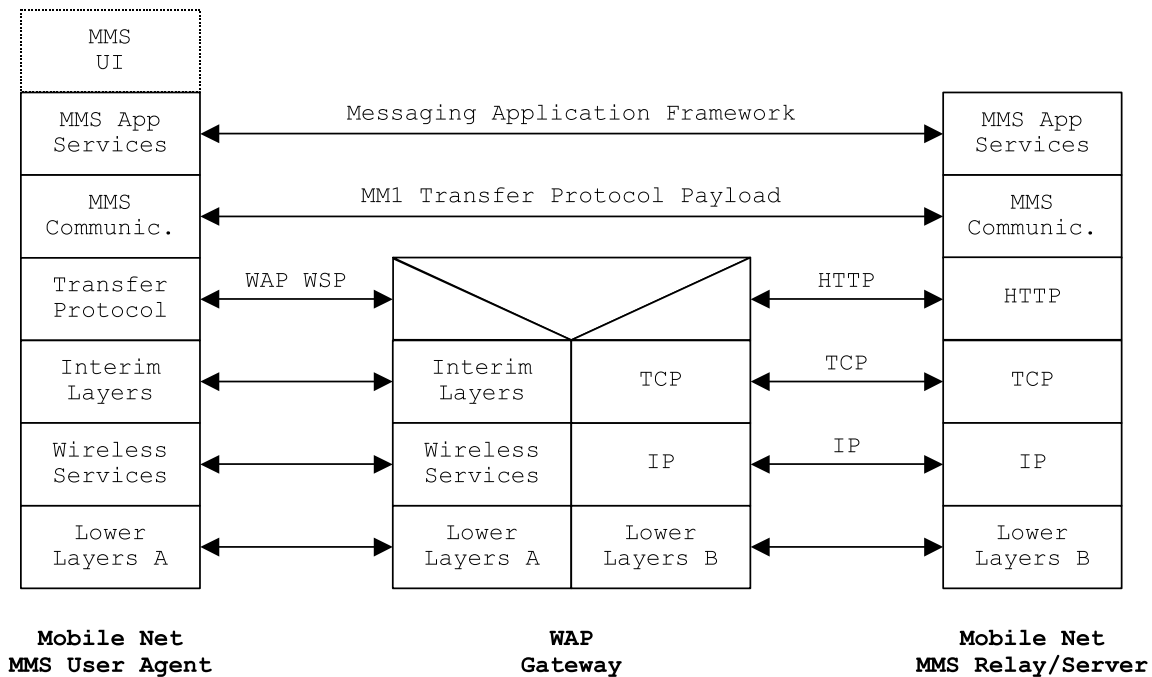

Figure 12: MM1 protocol layers used in mobile networks today

---

## History

| <b>Document history</b> |            |                     |
|-------------------------|------------|---------------------|
| V0.0.1                  | March 2002 | Initial draft text. |
|                         |            |                     |
|                         |            |                     |
|                         |            |                     |
|                         |            |                     |