



## **Enabler Release Definition for MMS Version 1.2**

### **Candidate Version 23-September-2003**

---

Open Mobile Alliance  
OMA-ERELED-MMS-v1\_2-20030923-C

Use of this document is subject to all of the terms and conditions of the Use Agreement located at <http://www.openmobilealliance.org/UseAgreement.html>.

Unless this document is clearly designated as an approved specification, this document is a work in process, is not an approved Open Mobile Alliance™ specification, and is subject to revision or removal without notice.

You may use this document or any part of the document for internal or educational purposes only, provided you do not modify, edit or take out of context the information in this document in any manner. Information contained in this document may be used, at your sole risk, for any purposes. You may not use this document in any other manner without the prior written permission of the Open Mobile Alliance. The Open Mobile Alliance authorizes you to copy this document, provided that you retain all copyright and other proprietary notices contained in the original materials on any copies of the materials and that you comply strictly with these terms. This copyright permission does not constitute an endorsement of the products or services. The Open Mobile Alliance assumes no responsibility for errors or omissions in this document.

Each Open Mobile Alliance member has agreed to use reasonable endeavors to inform the Open Mobile Alliance in a timely manner of Essential IPR as it becomes aware that the Essential IPR is related to the prepared or published specification. However, the members do not have an obligation to conduct IPR searches. The declared Essential IPR is publicly available to members and non-members of the Open Mobile Alliance and may be found on the “OMA IPR Declarations” list at <http://www.openmobilealliance.org/ipr.html>. The Open Mobile Alliance has not conducted an independent IPR review of this document and the information contained herein, and makes no representations or warranties regarding third party IPR, including without limitation patents, copyrights or trade secret rights. This document may contain inventions for which you must obtain licenses from third parties before making, using or selling the inventions. Defined terms above are set forth in the schedule to the Open Mobile Alliance Application Form.

NO REPRESENTATIONS OR WARRANTIES (WHETHER EXPRESS OR IMPLIED) ARE MADE BY THE OPEN MOBILE ALLIANCE OR ANY OPEN MOBILE ALLIANCE MEMBER OR ITS AFFILIATES REGARDING ANY OF THE IPR'S REPRESENTED ON THE “OMA IPR DECLARATIONS” LIST, INCLUDING, BUT NOT LIMITED TO THE ACCURACY, COMPLETENESS, VALIDITY OR RELEVANCE OF THE INFORMATION OR WHETHER OR NOT SUCH RIGHTS ARE ESSENTIAL OR NON-ESSENTIAL.

THE OPEN MOBILE ALLIANCE IS NOT LIABLE FOR AND HEREBY DISCLAIMS ANY DIRECT, INDIRECT, PUNITIVE, SPECIAL, INCIDENTAL, CONSEQUENTIAL, OR EXEMPLARY DAMAGES ARISING OUT OF OR IN CONNECTION WITH THE USE OF DOCUMENTS AND THE INFORMATION CONTAINED IN THE DOCUMENTS.

© 2003 Open Mobile Alliance Ltd. All Rights Reserved.

Used with the permission of the Open Mobile Alliance Ltd. under the terms set forth above.

# Contents

- 1. SCOPE .....4
- 2. REFERENCES.....5
  - 2.1. NORMATIVE REFERENCES .....5
  - 2.2. INFORMATIVE REFERENCES .....5
- 3. TERMINOLOGY AND CONVENTIONS .....6
  - 3.1. CONVENTIONS .....6
  - 3.2. DEFINITIONS .....6
  - 3.3. ABBREVIATIONS .....6
- 4. INTRODUCTION.....6
  - 4.1. EXAMPLE USE CASE .....6
- 5. ENABLER RELEASE SPECIFICATION BASELINE .....6
- 6. MINIMUM FUNCTIONALITY DESCRIPTION .....6
  - 6.1. MINIMUM FUNCTIONALITY OF MESSAGING TRANSACTIONS .....6
  - 6.2. MINIMUM SET OF MEDIA TYPE REQUIREMENTS .....6
- 7. CONFORMANCE REQUIREMENTS NOTATION DETAILS.....6
- 8. ERDEF FOR OMA MMS - CLIENT REQUIREMENTS .....6
- 9. ERDEF FOR OMA MMS - SERVER REQUIREMENTS .....6
- APPENDIX A. CHANGE HISTORY (INFORMATIVE) .....6

# 1. Scope

The scope of this document is limited to the Enabler Release Definition of Multimedia Messaging Service according to OMA Release process and the Enabler Release specification baseline listed in section 5.

Multimedia Messaging Service (MMS) is a system application by which a client is able to provide a messaging operation with a variety of media types. The service is described in terms of actions taken by the MMS Client and its service partner, the MMS Proxy-Relay, a device which operates as an Origin Server for this specialised service. [MMSARCH] provides the overall architectural picture of MMS and its protocol entities.

## 2. References

### 2.1. Normative References

- [CREQ] “Specification of WAP Conformance Requirements”. Open Mobile Alliance™. WAP-221-CREQ. <http://www.openmobilealliance.org>
- [RFC2119] “Key words for use in RFCs to Indicate Requirement Levels”. S. Bradner. March 1997. URL:<http://www.ietf.org/rfc/rfc2119.txt>
- [MMSCTR] “MMS Client Transactions”, Open Mobile Alliance™, OMA-WAP-MMS-CTR -v1\_2, <http://www.openmobilealliance.org/>
- [MMSENC] “MMS Encapsulation Protocol”, Open Mobile Alliance™, OMA-WAP-MMS-ENC-v1\_2, <http://www.openmobilealliance.org/>
- [MMSCONF] “MMS Conformance Document”, Open Mobile Alliance™, OMA-MMS-CONF-v1\_2, <http://www.openmobilealliance.org/>

### 2.2. Informative References

- [MMSARCH] “MMS Architecture Overview”, Open Mobile Alliance™, OMA-WAP-MMS-ARCH -v1\_2, <http://www.openmobilealliance.org/>
- [MMSCONF RD] “MMS Conformance Requirement”, Open Mobile Alliance™, OMA-MMS-RD-CONF-V1\_2, <http://www.openmobilealliance.org/>

## 3. Terminology and Conventions

### 3.1. Conventions

The key words “MUST”, “MUST NOT”, “REQUIRED”, “SHALL”, “SHALL NOT”, “SHOULD”, “SHOULD NOT”, “RECOMMENDED”, “MAY”, and “OPTIONAL” in this document are to be interpreted as described in [RFC2119].

All sections and appendixes, except “Scope” and “Introduction”, are normative, unless they are explicitly indicated to be informative.

The formal notation convention used in sections 8 and 9 to formally express the structure and internal dependencies between specifications in the Enabler Release specification baseline is detailed in [CREQ].

### 3.2. Definitions

#### Enabler Release

Collection of specifications that combined together form an enabler for a service area, e.g. a download enabler, a browsing enabler, a messaging enabler, a location enabler, etc. The specifications that are forming an enabler should combined fulfill a number of related market requirements.

#### Minimum Functionality Description

Description of the guaranteed features and functionality that will be enabled by implementing the minimum mandatory part of the Enabler Release.

#### MMS Encapsulation

The definition of the protocol data units, the fields and their encodings necessary to send and receive multimedia messages including multimedia objects.

### 3.3. Abbreviations

ERELED	Enabler Release Definition
ERDEF	Enabler Requirement Definition
OMA	Open Mobile Alliance
MMS	Multimedia Messaging Service
MM	Multimedia Message
PDU	Protocol Data Unit
SMTP	Simple Mail Transfer Protocol
POP	Post Office Protocol
IMAP	Internet Message Access Protocol
SMS	Short Message Service
WSP	Wireless Session Protocol
HTTP	Hyper Text Transfer Protocol

## 4. Introduction

This document outlines the Enabler Release Definition for OMA Multimedia Messaging Service (MMS) and the respective conformance requirements for clients and servers implementing claiming compliance to it as defined by Open Mobile Alliance across the specification baseline.

A key feature of MMS is the ability to support messaging activities with other available messaging systems. This is shown in Figure 1 below which shows an abstract view of an MMS network diagram. It is expected that specific MMS networks may have one or more such connections as well as include specific messaging services not directly represented (e.g. fax or voice mail systems).

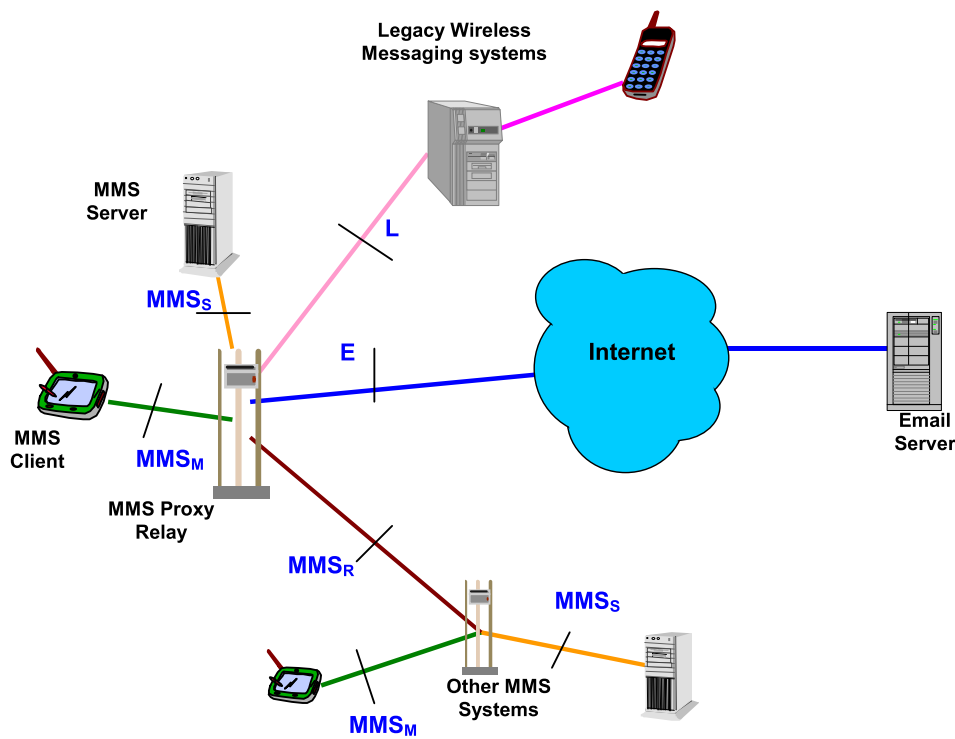

Figure 1 MMS Network Representation

Note that although Figure 1 identifies various interfaces, in some cases, their definition will be for further study. The mention of these interfaces in this document does not imply that the OMA will develop the specifications necessary to describe them in detail.

The system elements shown in Figure 1 can be summarised as follows:

- **MMS Client** – This is the system element that interacts with the user. It is expected to be implemented as an application on the user’s wireless device.
- **MMS Proxy-Relay** – This is the system element that the MMS Client interacts with. It provides access to the components that provide message storage services, and it is responsible for messaging activities with other available messaging systems. Some implementations may combine this component with the MMS Server.
- **MMS Server** – This system element provides storage services for MM messages. Some implementations may combine this component with the MMS Proxy-Relay.
- **Email Server** – This system element provides traditional Internet email services. It supports the SMTP protocol to send messages as well as POP and/or IMAP protocols to retrieve messages.
- **Legacy Wireless Messaging Systems** – This system element represents various systems that currently exist in support of wireless messaging systems. This would include paging and SMS systems that provide messaging to a large number of subscribers.

The interfaces shown in the diagram are described as follows:

- **MMS<sub>m</sub>** – the interface defined between the MMS Client and the MMS Proxy-Relay.
- **MMS<sub>s</sub>** - the interface defined between the MMS Server and the MMS Proxy-Relay. This interface may be transcendental when the MMS Server and MMS Proxy-Relay are combined into a single component.
- **MMS<sub>R</sub>** - the interface defined between MMS Proxy-Relays of separate MMS Systems.
- **E** - the standard email interface used between the MMS Proxy-Relay and internet-based email systems utilising SMTP, POP and IMAP transport protocols.
- **L** - the interfaces used between the MMS Proxy-Relay and legacy wireless messaging systems. As there are various such systems, this is viewed as being a set of interfaces.

## 4.1. Example Use Case

The following example information flow for a use case is provided to further illustrate the functions and roles of the various system elements in the MMS framework. The example given here concerns end-to-end MMS messaging between terminals.

1. User activates MMS Client (assumed to be available on terminal).
2. User selects or enters MM target address(es).
3. User composes/edits MM to be sent.
4. User requests that MM is sent.
5. MMS Client submits the message to its associated MMS Proxy-Relay via the MMS<sub>M</sub> interface.
6. MMS Proxy-Relay resolves the MM target address(es).
7. MMS Proxy-Relay routes forward the MM to each target MMS Proxy-Relay via the MMS<sub>R</sub> interface.
8. The MM is stored by the MMS Server associated with the target MMS Proxy-Relay.
9. Target MMS Proxy-Relay sends a notification to target MMS Client via the MMS<sub>M</sub> interface.
10. Target MMS Client retrieves the MM from the MMS Server.
11. Target MMS Client notifies target user of new MM available.
12. Target user requests rendering of received MM.

13. Target MMS Client renders MM on target user's terminal.

Note that steps 1-3 and 12-13 concern the User Interface on the terminal which is considered implementation dependent and therefore outside the scope of this specification. Also note that steps 10 and 11 could occur in reverse order depending on MMS Client implementation, that is, an MM retrieval policy could cause the MMS Client to retrieve an MM only when so allowed by the user.

## 5. Enabler Release Specification Baseline

The following specifications comprise the OMA MMS enabler release:

“MMS Architecture Overview Version 1.2”	[MMSARCH]
“MMS Client Transactions Version 1.2”	[MMSCTR]
“MMS Encapsulation Protocol Version 1.2”	[MMSENC]
“MMS Conformance Document Version 1.2”	[MMSCONF]
“MMS Conformance Requirement Version 1.2”	[MMSCONFRD]

## 6. Minimum Functionality Description

### 6.1. Minimum Functionality of Messaging Transactions

This section is informative.

MMS Architecture Overview specification is the informative document and thus doesn't contain the functionality requirement.

The minimum functionality for a device implementing OMA MMS is to support the following client-server transactions specified in the MMS Client Transactions specification.

- (1) MMS Client Sending Message to MMS Proxy-Relay
- (2) MMS Proxy-Relay Sending Notification to MMS Client
- (3) MMS Client Retrieving Message from MMS Proxy-Relay
- (4) MMS Proxy-Relay Sending Delivery Report to MMS Client

Note that a client device can implement either of message sending transactions that are (1) & (4), or message receiving transactions that are (2) and (3), or both of sending and receiving.

In addition, MMS Encapsulation specification provides the corresponding PDUs used in the transactions and thus a device implementing OMA MMS also needs to support the mandatory features in each of the corresponding PDU listed below. Correspondence between the transaction and PDU is provided by the SCR table (Appendix A) of [MMSCTR].

- PDU for "Send message to MMS Proxy-Relay" (M-Send.req, M-Send.conf)
- PDU for "Retrieve message from MMS Proxy-Relay" (WSP/HTTP GET.req, M-Retrieve.conf)
- PDU for "MMS Notification about new message" (M-Notification.ind, M-NotifyResp.ind)
- PDU for "Delivery Report about sent message" (M-Delivery.ind)
- PDU for "Acknowledgement of message delivery" (M-Acknowledge.ind)

Since MMS is an application-level protocol framework to enable messaging transactions, a device implementing OMA MMS must have either of WAP WSP stack or HTTP/TCP/IP stack, with WAP PUSH functionality to support Notification transaction and Delivery Report transaction, in order to convey PDUs above. More detail of transport binding and the dependencies are provided in the chapter 9 and 10 respectively in [MMSCTR]

### 6.2. Minimum set of media type requirements

This section is informative.

A device implementing OMA MMS must support text/plain MIME type according to [MMSENC]. This enables a basic messaging service. If a device supports more media types than text/plain, it must conform a minimum set of the requirements related to the content of the message, the message presentation, media object formats as defined in [MMSCONF]. That document also specifies the minimum requirement for lower protocol capability such as WTP SAR, in order to guarantee the delivery of the message content. See [MMSENC] for more detail.



## 7. Conformance Requirements Notation Details

This section is informative

The tables in following chapters use the following notation:

**Item:**

Entry in this column **MUST** be a valid ScrItem according to [CREQ].

**Feature/Application:**

Entry in this column **SHOULD** be a short descriptive label to the **Item** in question.

**Status:**

Entry in this column **MUST** accurately reflect the architectural status of the **Item** in question.

- M means the **Item** is mandatory for the class
- O means the **Item** is optional for the class
- NA means the **Item** is not applicable for the class

**Requirement:**

Expression in the column **MUST** be a valid TerminalExpression according to [CREQ] and it **MUST** accurately reflect the architectural requirement of the **Item** in question.

## 8. ERDEF for OMA MMS - Client Requirements

Table 1 ERDEF for OMA Client-side Requirements

Item	Feature / Application	Status	Requirement
OMA-ERDEF-MMS-C-001	Text-only Messaging Client	M	MMSCTR:MCF AND MMSENC:MCF
OMA-ERDEF-MMS-C-002	Basic MMS Client	O	OMA-ERDEF-MMS-C-001 AND MMSCONF:MCF

## 9. ERDEF for OMA MMS - Server Requirements

Table 2 ERDEF for OMA MMS Server-side Requirements

Item	Feature / Application	Status	Requirement
OMA-ERDEF-MMS-S-001	MMS Proxy-Relay Server	M	MMSCTR:MSF AND MMSENC:MSF AND MMSCONF:MSF

## Appendix A. Change History

(Informative)

### A.1 Approved Version History

Reference	Date	Description
n/a	n/a	No previous version within OMA

### A.2 Draft/Candidate Version 1.2 History

Document Identifier	Date	Sections	Description
Candidate Version OMA-ERELED-MMS-v1_1- 20021104-C	04 Nov 2002		Initial Candidate version in OMA
Draft Version OMA-ERELED-MMS-v1_2- 20030611-D	11 Jun 2003		Updated Draft version for OMA MMS 1_2 for TP approval
Candidate Version OMA-ERELED-MMS-v1_2- 20030716-C	16 Jul 2003		Status Changed to Candidate by TP TP ref# OMA-TP-2003-0303
Candidate Version OMA-ERELED-MMS-v1_2- 20030923-C	23 Sep 2003		Updates based on latest candidate versions (dates only)