



US009198042B2

(12) **United States Patent**
Raleigh

(10) **Patent No.:** **US 9,198,042 B2**
(45) **Date of Patent:** **Nov. 24, 2015**

(54) **SECURITY TECHNIQUES FOR DEVICE ASSISTED SERVICES**

IPC H04M 2215/32; H04L 63/20
See application file for complete search history.

(71) Applicant: **Headwater Partners I LLC**, Redwood Shores, CA (US)

(56) **References Cited**

(72) Inventor: **Gregory G. Raleigh**, Woodside, CA (US)

U.S. PATENT DOCUMENTS

5,131,020 A 7/1992 Liebesny et al.
5,283,904 A 2/1994 Carson et al.

(73) Assignee: **Headwater Partners I LLC**, Redwood City, CA (US)

(Continued)

(*) Notice: Subject to any disclaimer, the term of this patent is extended or adjusted under 35 U.S.C. 154(b) by 451 days.

CA 2688553 A1 12/2008
CN 1310401 A 8/2001

(Continued)

(21) Appl. No.: **13/737,748**

OTHER PUBLICATIONS

(22) Filed: **Jan. 9, 2013**

“Communication Concepts for Mobile Agent Systems,” by Joachim Baumann et al.; Inst. Of Parallel and Distributed High-Performance Systems, Univ. of Stuttgart, Germany, pp. 123-135, 1997.

(65) **Prior Publication Data**

(Continued)

US 2013/0145422 A1 Jun. 6, 2013

Related U.S. Application Data

(63) Continuation of application No. 12/694,445, filed on Jan. 27, 2010, now Pat. No. 8,391,834, which is a continuation of application No. 12/380,780, filed on Mar. 2, 2009, now Pat. No. 8,839,388.

(Continued)

(51) **Int. Cl.**
H04L 29/06 (2006.01)
H04M 11/00 (2006.01)

(Continued)

(52) **U.S. Cl.**
CPC **H04W 12/08** (2013.01); **G06F 21/53** (2013.01); **G06F 21/55** (2013.01);

(Continued)

(58) **Field of Classification Search**
USPC 455/405, 406, 411, 414.1, 417, 432.1; 370/352, 354; 709/203, 217, 219, 223; 726/1, 26; 705/28, 30

Primary Examiner — Andrew Joseph Rudy

(74) Attorney, Agent, or Firm — James E. Harris

(57) **ABSTRACT**

Methods and systems for receiving a report from an end-user device, the report comprising information about a device service state; determining, based on the report, that a particular service policy setting of the end-user device needs to be modified, the particular service policy setting associated with a service profile that provides for access to a network data service over a wireless access network and configured to assist in controlling one or more communications between the end-user device and the wireless access network, the particular service policy setting stored in a protected partition configured to deter or prevent unauthorized modifications to the particular service policy setting; and, in response to determining that the particular service policy setting needs to be modified, sending configuration information to the end-user device, the configuration information configured to assist in modifying or allowing modifications to the particular service policy setting.

18 Claims, 11 Drawing Sheets

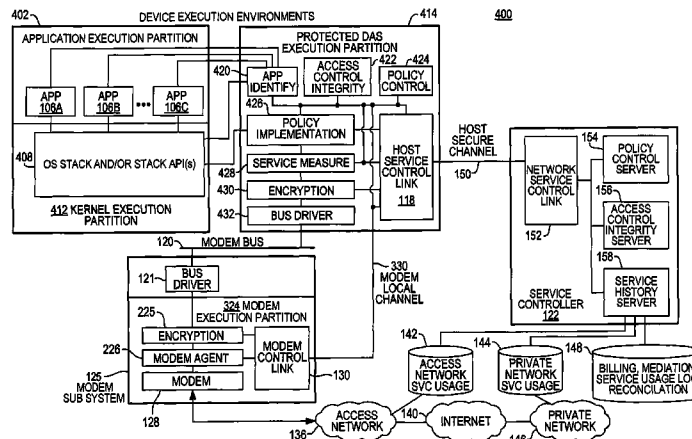

Related U.S. Application Data

- (60) Provisional application No. 61/206,354, filed on Jan. 28, 2009, provisional application No. 61/206,944, filed on Feb. 4, 2009, provisional application No. 61/207,393, filed on Feb. 10, 2009, provisional application No. 61/207,739, filed on Feb. 13, 2009, provisional application No. 61/252,151, filed on Oct. 15, 2009, provisional application No. 61/206,354, filed on Jan. 28, 2009, provisional application No. 61/206,944, filed on Feb. 4, 2009, provisional application No. 61/207,393, filed on Feb. 10, 2009, provisional application No. 61/207,739, filed on Feb. 13, 2009.

(51) **Int. Cl.**

H04W 12/08 (2009.01)

G06F 21/53 (2013.01)

G06F 21/55 (2013.01)

(52) **U.S. Cl.**

CPC ... **H04L 63/0428** (2013.01); **G06F 2221/2101** (2013.01); **G06F 2221/2115** (2013.01); **G06F 2221/2149** (2013.01); **H04L 63/145** (2013.01)

(56)

References Cited

U.S. PATENT DOCUMENTS

5,325,532 A 6/1994 Crosswy et al.
 5,572,528 A 11/1996 Shuen
 5,577,100 A 11/1996 McGregor et al.
 5,594,777 A 1/1997 Makkonen et al.
 5,630,159 A 5/1997 Zanchó
 5,633,484 A 5/1997 Zanchó et al.
 5,754,953 A 5/1998 Briancon et al.
 5,774,532 A 6/1998 Gottlieb et al.
 5,794,142 A 8/1998 Vanttila et al.
 5,814,798 A 9/1998 Zanchó
 5,889,477 A 3/1999 Fastenrath
 5,892,900 A 4/1999 Ginter et al.
 5,903,845 A 5/1999 Buhrmann et al.
 5,915,008 A 6/1999 Dulman
 5,933,778 A 8/1999 Buhrmann et al.
 5,940,472 A 8/1999 Newman et al.
 5,974,439 A 10/1999 Bollella
 5,983,270 A 11/1999 Abraham et al.
 6,035,281 A 3/2000 Crosskey et al.
 6,038,452 A 3/2000 Strawczynski et al.
 6,047,268 A 4/2000 Bartoli et al.
 6,064,878 A 5/2000 Denker et al.
 6,078,953 A 6/2000 Vaid et al.
 6,081,591 A 6/2000 Skoog
 6,098,878 A 8/2000 Dent et al.
 6,104,700 A 8/2000 Haddock et al.
 6,119,933 A 9/2000 Wong et al.
 6,141,686 A 10/2000 Jackowski et al.
 6,148,336 A 11/2000 Thomas et al.
 6,154,738 A 11/2000 Call
 6,185,576 B1 2/2001 Mcintosh
 6,198,915 B1 3/2001 McGregor et al.
 6,226,277 B1 5/2001 Chuah
 6,263,055 B1 7/2001 Garland et al.
 6,292,828 B1 9/2001 Williams
 6,317,584 B1 11/2001 Abu-Amara et al.
 6,381,316 B2 4/2002 Joyce et al.
 6,393,014 B1 5/2002 Daly et al.
 6,397,259 B1 5/2002 Lincke et al.
 6,418,147 B1 7/2002 Wiedeman
 6,438,575 B1 8/2002 Khan et al.
 6,445,777 B1 9/2002 Clark
 6,449,479 B1 9/2002 Sanchez
 6,477,670 B1 11/2002 Ahmadvand
 6,502,131 B1 12/2002 Vaid et al.
 6,505,114 B2 1/2003 Luciani
 6,532,235 B1 3/2003 Benson et al.
 6,532,579 B2 3/2003 Sato et al.

6,539,082 B1 3/2003 Lowe et al.
 6,542,992 B1 4/2003 Peirce et al.
 6,563,806 B1 5/2003 Yano et al.
 6,574,321 B1 6/2003 Cox et al.
 6,574,465 B2 6/2003 Marsh et al.
 6,578,076 B1 6/2003 Putzolu
 6,581,092 B1 6/2003 Motoyama
 6,598,034 B1 7/2003 Kloth
 6,603,969 B1 8/2003 Vuoristo et al.
 6,606,744 B1 8/2003 Mikurak
 6,628,934 B2 9/2003 Rosenberg et al.
 6,631,122 B1 10/2003 Arunachalam et al.
 6,639,975 B1 10/2003 O'Neal et al.
 6,640,097 B2 10/2003 Corrigan et al.
 6,640,334 B1 10/2003 Rasmussen
 6,650,887 B2 11/2003 McGregor et al.
 6,651,101 B1 11/2003 Gai et al.
 6,654,814 B1 11/2003 Britton et al.
 6,658,254 B1 12/2003 Purdy et al.
 6,662,014 B1 12/2003 Walsh
 6,678,516 B2 1/2004 Nordman et al.
 6,683,853 B1 1/2004 Kannas et al.
 6,684,244 B1 1/2004 Goldman et al.
 6,697,821 B2 2/2004 Ziff et al.
 6,725,031 B2 4/2004 Watler et al.
 6,748,195 B1 6/2004 Phillips
 6,754,470 B2 6/2004 Hendrickson et al.
 6,757,717 B1 6/2004 Goldstein
 6,763,000 B1 7/2004 Walsh
 6,763,226 B1 7/2004 McZeal, Jr.
 6,765,864 B1 7/2004 Natarajan et al.
 6,765,925 B1 7/2004 Sawyer et al.
 6,782,412 B2 8/2004 Brophy et al.
 6,785,889 B1 8/2004 Williams
 6,829,596 B1 12/2004 Frazee
 6,829,696 B1 12/2004 Balmer et al.
 6,839,340 B1 1/2005 Voit et al.
 6,873,988 B2 3/2005 Herrmann et al.
 6,876,653 B2 4/2005 Ambe et al.
 6,882,718 B1 4/2005 Smith
 6,885,997 B1 4/2005 Roberts
 6,901,440 B1 5/2005 Bimm et al.
 6,920,455 B1 7/2005 Weschler
 6,922,562 B2 7/2005 Ward et al.
 6,928,280 B1 8/2005 Xanthos et al.
 6,934,249 B1 8/2005 Bertin et al.
 6,947,723 B1 9/2005 Gurnani et al.
 6,952,428 B1 10/2005 Necka et al.
 6,957,067 B1 10/2005 Iyer et al.
 6,965,667 B2 11/2005 Trabant et al.
 6,965,872 B1 11/2005 Grdina
 6,967,958 B2 11/2005 Ono et al.
 6,970,692 B2 11/2005 Tysor
 6,982,733 B1 1/2006 McNally et al.
 6,983,370 B2 1/2006 Eaton et al.
 6,996,076 B1 2/2006 Forbes et al.
 6,996,393 B2 2/2006 Pyhalammi et al.
 6,998,985 B2 2/2006 Reisman et al.
 7,002,920 B1 2/2006 Ayyagari et al.
 7,007,295 B1 2/2006 Rose et al.
 7,013,469 B2 3/2006 Smith et al.
 7,024,200 B2 4/2006 McKenna et al.
 7,027,408 B2 4/2006 Nabkel et al.
 7,032,072 B1 4/2006 Quinn et al.
 7,039,027 B2 5/2006 Bridgelall
 7,039,037 B2 5/2006 Wang et al.
 7,039,403 B2 5/2006 Wong
 7,039,713 B1 5/2006 Van Gunter et al.
 7,042,988 B2 5/2006 Juitt et al.
 7,043,226 B2 5/2006 Yamauchi
 7,043,268 B2 5/2006 Yukie et al.
 7,047,276 B2 5/2006 Liu et al.
 7,058,022 B1 6/2006 Carolan et al.
 7,058,968 B2 6/2006 Rowland et al.
 7,068,600 B2 6/2006 Cain
 7,069,248 B2 6/2006 Huber
 7,084,775 B1 8/2006 Smith
 7,092,696 B1 8/2006 Hosain et al.
 7,102,620 B2 9/2006 Harries et al.

(56)

References Cited

U.S. PATENT DOCUMENTS

7,113,780 B2	9/2006	Mckenna et al.	7,460,837 B2	12/2008	Diener
7,113,997 B2	9/2006	Jayapalan et al.	7,472,189 B2	12/2008	Mallya et al.
7,133,695 B2	11/2006	Beyda	7,478,420 B2	1/2009	Wright et al.
7,139,569 B2	11/2006	Kato	7,486,185 B2	2/2009	Culpepper et al.
7,142,876 B2	11/2006	Trossen et al.	7,493,659 B1	2/2009	Wu et al.
7,149,229 B1	12/2006	Leung	7,496,652 B2	2/2009	Pezzutti
7,149,521 B2	12/2006	Sundar et al.	7,499,438 B2	3/2009	Hinman et al.
7,158,792 B1	1/2007	Cook et al.	7,499,537 B2	3/2009	Elsey et al.
7,162,237 B1 *	1/2007	Silver H04W 4/02 455/417	7,502,672 B1	3/2009	Kolls
7,167,078 B2	1/2007	Pourchot	7,508,799 B2	3/2009	Sumner et al.
7,174,174 B2	2/2007	Boris et al.	7,515,608 B2	4/2009	Yuan et al.
7,180,855 B1	2/2007	Lin	7,515,926 B2	4/2009	Bu et al.
7,181,017 B1	2/2007	Nagel et al.	7,516,219 B2	4/2009	Moghaddam et al.
7,197,321 B2	3/2007	Erskine et al.	7,529,204 B2	5/2009	Bourlas et al.
7,200,112 B2	4/2007	Sundar et al.	7,535,880 B1	5/2009	Hinman et al.
7,203,169 B1	4/2007	Okholm	7,536,695 B2	5/2009	Alam et al.
7,203,752 B2	4/2007	Rice et al.	7,539,132 B2	5/2009	Werner et al.
7,212,491 B2	5/2007	Koga	7,540,408 B2	6/2009	Levine et al.
7,222,190 B2	5/2007	Klinker et al.	7,545,782 B2	6/2009	Rayment et al.
7,222,304 B2	5/2007	Beaton et al.	7,546,460 B2	6/2009	Maes
7,224,968 B2	5/2007	Dobson et al.	7,546,629 B2	6/2009	Albert et al.
7,228,354 B2	6/2007	Chambliss et al.	7,548,976 B2	6/2009	Bahl et al.
7,236,780 B2	6/2007	Benco et al.	7,551,922 B2	6/2009	Roskowski et al.
7,242,668 B2	7/2007	Kan et al.	7,554,983 B1	6/2009	Muppala
7,242,920 B2	7/2007	Morris	7,555,757 B2	6/2009	Smith et al.
7,245,901 B2	7/2007	McGregor et al.	7,561,899 B2	7/2009	Lee
7,251,218 B2	7/2007	Jorgensen	7,564,799 B2	7/2009	Holland et al.
7,260,382 B1	8/2007	Lamb et al.	7,565,141 B2	7/2009	Macaluso
7,266,371 B1	9/2007	Amin et al.	7,574,509 B2	8/2009	Nixon et al.
7,271,765 B2	9/2007	Stilp et al.	7,574,731 B2	8/2009	Fascenda
7,280,816 B2	10/2007	Fratti et al.	7,580,356 B1	8/2009	Mishra et al.
7,280,818 B2	10/2007	Clayton	7,580,857 B2	8/2009	VanFleet et al.
7,283,561 B1	10/2007	Picher-Dempsey	7,583,964 B2	9/2009	Wong
7,283,963 B1	10/2007	Fitzpatrick et al.	7,586,871 B2	9/2009	Hamilton et al.
7,286,834 B2	10/2007	Walter	7,593,417 B2	9/2009	Wang et al.
7,286,848 B2	10/2007	Vireday et al.	7,593,730 B2	9/2009	Khandelwal et al.
7,289,489 B1	10/2007	Kung et al.	7,596,373 B2	9/2009	Mcgregor et al.
7,290,283 B2	10/2007	Copeland, III	7,599,288 B2	10/2009	Cole et al.
7,310,424 B2	12/2007	Gehring et al.	7,609,650 B2	10/2009	Roskowski et al.
7,313,237 B2	12/2007	Bahl et al.	7,609,700 B1	10/2009	Ying et al.
7,317,699 B2	1/2008	Godfrey et al.	7,610,328 B2	10/2009	Haase et al.
7,318,111 B2	1/2008	Zhao	7,610,396 B2	10/2009	Taglienti et al.
7,320,029 B2	1/2008	Rinne et al.	7,614,051 B2	11/2009	Glaum et al.
7,322,044 B2	1/2008	Hrastar	7,616,962 B2	11/2009	Oswal et al.
7,324,447 B1	1/2008	Morford	7,617,516 B2	11/2009	Huslak et al.
7,325,037 B2	1/2008	Lawson	7,620,041 B2	11/2009	Dunn et al.
7,336,960 B2	2/2008	Zavalkovsky et al.	7,620,065 B2	11/2009	Falardeau
7,346,410 B2	3/2008	Uchiyama	7,620,162 B2	11/2009	Aaron et al.
7,349,695 B2	3/2008	Oommen et al.	7,627,314 B2	12/2009	Carlson et al.
7,353,533 B2	4/2008	Wright et al.	7,627,767 B2	12/2009	Sherman et al.
7,356,011 B1	4/2008	Waters et al.	7,627,872 B2	12/2009	Hebeler et al.
7,356,337 B2	4/2008	Florence	7,633,438 B2	12/2009	Tysowski
7,366,497 B2	4/2008	Nagata	7,634,388 B2	12/2009	Archer et al.
7,366,654 B2	4/2008	Moore	7,636,574 B2	12/2009	Poosala
7,373,136 B2	5/2008	Watler et al.	7,644,151 B2	1/2010	Jerrim et al.
7,373,179 B2	5/2008	Stine et al.	7,644,267 B2	1/2010	Ylikoski et al.
7,379,731 B2	5/2008	Natsuno et al.	7,647,047 B2	1/2010	Moghaddam et al.
7,388,950 B2	6/2008	Elsey et al.	7,650,137 B2	1/2010	Jobs et al.
7,391,724 B2	6/2008	Alakoski et al.	7,653,394 B2	1/2010	McMillin
7,395,244 B1	7/2008	Kingsford	7,668,176 B2	2/2010	Chuah
7,401,338 B1	7/2008	Bowen et al.	7,668,612 B1	2/2010	Okkonen
7,403,763 B2	7/2008	Maes	7,668,903 B2	2/2010	Edwards et al.
7,409,447 B1	8/2008	Assadzadeh	7,684,370 B2	3/2010	Kezys
7,411,930 B2	8/2008	Montojo et al.	7,685,131 B2	3/2010	Batra et al.
7,418,253 B2	8/2008	Kavanagh	7,685,254 B2	3/2010	Pandya
7,418,257 B2	8/2008	Kim	7,685,530 B2	3/2010	Sherrard et al.
7,421,004 B2	9/2008	Fehér	7,693,720 B2	4/2010	Kennewick et al.
7,444,669 B1	10/2008	Bahl et al.	7,697,540 B2	4/2010	Haddad et al.
7,450,591 B2	11/2008	Korling et al.	7,710,932 B2	5/2010	Muthuswamy et al.
7,450,927 B1	11/2008	Creswell et al.	7,711,848 B2	5/2010	Maes
7,454,191 B2 *	11/2008	Dawson G06Q 10/1091 379/114.12	7,720,464 B2	5/2010	Batta
7,457,265 B2	11/2008	Julka et al.	7,720,505 B2	5/2010	Gopi et al.
7,457,870 B1	11/2008	Lownsborough et al.	7,720,960 B2	5/2010	Pruss et al.
			7,725,570 B1	5/2010	Lewis
			7,729,326 B2	6/2010	Sekhar
			7,730,123 B1	6/2010	Erickson et al.
			7,734,784 B1	6/2010	Araujo et al.
			7,742,406 B1	6/2010	Muppala
			7,746,854 B2	6/2010	Ambe et al.

(56)

References Cited

U.S. PATENT DOCUMENTS

7,747,240 B1	6/2010	Briscoe et al.	7,940,685 B1	5/2011	Breslau et al.
7,747,699 B2	6/2010	Prueitt et al.	7,940,751 B2	5/2011	Hansen
7,747,730 B1	6/2010	Harlow	7,941,184 B2	5/2011	Prendergast et al.
7,752,330 B2	7/2010	Olsen et al.	7,944,948 B2	5/2011	Chow et al.
7,756,056 B2	7/2010	Kim et al.	7,945,238 B2	5/2011	Baker et al.
7,756,534 B2	7/2010	Anupam et al.	7,945,240 B1	5/2011	Klock et al.
7,756,757 B1	7/2010	Oakes, III	7,945,945 B2	5/2011	Graham et al.
7,760,137 B2	7/2010	Martucci et al.	7,948,952 B2	5/2011	Hurtta et al.
7,760,711 B1	7/2010	Kung et al.	7,948,953 B2	5/2011	Melkote et al.
7,760,861 B1	7/2010	Croak et al.	7,948,968 B2	5/2011	Voit et al.
7,774,323 B2	8/2010	Helfman	7,949,529 B2	5/2011	Weider et al.
7,774,456 B1	8/2010	Lownsborough et al.	7,953,808 B2	5/2011	Sharp et al.
7,778,176 B2	8/2010	Morford	7,953,877 B2	5/2011	Vemula et al.
7,778,643 B2	8/2010	Larota et al.	7,957,020 B2	6/2011	Mine et al.
7,792,257 B1	9/2010	Vanier et al.	7,957,381 B2	6/2011	Clermidy et al.
7,792,538 B2	9/2010	Kozisek	7,957,511 B2	6/2011	Drudis et al.
7,792,708 B2	9/2010	Alva	7,958,029 B1	6/2011	Bobich et al.
7,797,060 B2	9/2010	Grgic et al.	7,962,622 B2	6/2011	Friend et al.
7,797,204 B2	9/2010	Balent	7,965,983 B1	6/2011	Swan et al.
7,797,401 B2	9/2010	Stewart et al.	7,969,950 B2	6/2011	Iyer et al.
7,801,523 B1	9/2010	Kenderov	7,970,350 B2	6/2011	Sheynman et al.
7,801,783 B2	9/2010	Kende et al.	7,970,426 B2	6/2011	Poe et al.
7,801,985 B1	9/2010	Pitkow et al.	7,974,624 B2	7/2011	Gallagher et al.
7,802,724 B1	9/2010	Nohr	7,975,184 B2	7/2011	Goff et al.
7,805,140 B2	9/2010	Friday et al.	7,978,627 B2	7/2011	Taylor et al.
7,805,606 B2	9/2010	Birger et al.	7,978,686 B2	7/2011	Goyal et al.
7,809,351 B1	10/2010	Panda et al.	7,984,130 B2	7/2011	Bogineni et al.
7,817,615 B1 *	10/2010	Breau H04W 28/24 370/349	7,984,511 B2	7/2011	Kocher et al.
7,822,837 B1	10/2010	Urban et al.	7,986,935 B1	7/2011	D'Souza et al.
7,826,427 B2	11/2010	Sood et al.	7,987,496 B2	7/2011	Bryce et al.
7,826,607 B1	11/2010	De Carvalho Resende et al.	7,987,510 B2	7/2011	Kocher et al.
7,843,843 B1	11/2010	Papp, III et al.	7,990,049 B2	8/2011	Shioya
7,844,034 B1 *	11/2010	Oh H04M 3/5116 370/261	8,000,276 B2	8/2011	Scherzer et al.
7,844,728 B2	11/2010	Anderson et al.	8,000,318 B2	8/2011	Wiley et al.
7,848,768 B2	12/2010	Omori et al.	8,005,009 B2	8/2011	McKee et al.
7,849,161 B2	12/2010	Koch et al.	8,005,459 B2	8/2011	Balsillie
7,849,477 B2	12/2010	Cristofalo et al.	8,005,726 B1	8/2011	Bao
7,853,255 B2	12/2010	Karaoguz et al.	8,005,988 B2	8/2011	Maes
7,856,226 B2	12/2010	Wong et al.	8,010,080 B1	8/2011	Thenthiruperai et al.
7,860,088 B2	12/2010	Lioy	8,010,081 B1	8/2011	Roskowski
7,865,182 B2	1/2011	Macaluso	8,010,082 B2	8/2011	Sutaria et al.
7,865,187 B2	1/2011	Ramer et al.	8,015,133 B1	9/2011	Wu et al.
7,868,778 B2	1/2011	Kenwright	8,015,234 B2	9/2011	Lum et al.
7,873,344 B2	1/2011	Bowser et al.	8,019,687 B2	9/2011	Wang et al.
7,873,705 B2	1/2011	Kalish	8,019,820 B2	9/2011	Son et al.
7,877,090 B2	1/2011	Maes	8,019,846 B2	9/2011	Roelens et al.
7,881,199 B2	2/2011	Krstulich	8,019,868 B2	9/2011	Rao et al.
7,881,697 B2	2/2011	Baker et al.	8,019,886 B2	9/2011	Harrang et al.
7,882,029 B2	2/2011	White	8,023,425 B2	9/2011	Raleigh
7,886,047 B1	2/2011	Potluri	8,024,397 B1	9/2011	Erickson et al.
7,890,084 B1	2/2011	Dudziak et al.	8,027,339 B2	9/2011	Short et al.
7,890,111 B2	2/2011	Bugenhagen	8,031,601 B2	10/2011	Feroz et al.
7,894,431 B2	2/2011	Goring et al.	8,032,409 B1	10/2011	Mikurak
7,899,039 B2 *	3/2011	Andreasen H04L 12/1403 370/354	8,032,899 B2	10/2011	Archer et al.
7,899,438 B2	3/2011	Baker et al.	8,036,600 B2	10/2011	Garrett et al.
7,903,553 B2	3/2011	Liu	8,045,973 B2	10/2011	Chambers
7,907,970 B2	3/2011	Park et al.	8,046,449 B2	10/2011	Yoshiuchi
7,911,975 B2	3/2011	Droz et al.	8,050,275 B1	11/2011	Iyer
7,912,025 B2	3/2011	Pattenden et al.	8,050,690 B2	11/2011	Neeraj
7,912,056 B1	3/2011	Brassem	8,050,705 B2	11/2011	Sicher et al.
7,920,529 B1	4/2011	Mahler et al.	8,059,530 B1	11/2011	Cole
7,921,463 B2	4/2011	Sood et al.	8,060,463 B1	11/2011	Spiegel
7,925,778 B1	4/2011	Wijnands et al.	8,064,418 B2	11/2011	Maki
7,929,959 B2	4/2011	DeAtley et al.	8,064,896 B2	11/2011	Bell et al.
7,929,960 B2	4/2011	Martin et al.	8,068,824 B2	11/2011	Shan et al.
7,929,973 B2	4/2011	Zavalkovsky et al.	8,068,829 B2	11/2011	Lemond et al.
7,930,327 B2	4/2011	Craft et al.	8,073,427 B2	12/2011	Koch et al.
7,930,446 B2	4/2011	Kesselman et al.	8,073,721 B1	12/2011	Lewis
7,933,274 B2	4/2011	Verma et al.	8,078,140 B2	12/2011	Baker et al.
7,936,736 B2	5/2011	Proctor, Jr. et al.	8,078,163 B2	12/2011	Lemond et al.
7,937,069 B2	5/2011	Rassam	8,086,398 B2	12/2011	Sanchez et al.
7,937,450 B2	5/2011	Janik	8,086,497 B1	12/2011	Oakes, III
			8,086,791 B2	12/2011	Caulkins
			8,090,359 B2	1/2012	Proctor, Jr. et al.
			8,090,616 B2	1/2012	Proctor, Jr. et al.
			8,094,551 B2	1/2012	Huber et al.
			8,095,112 B2	1/2012	Chow et al.
			8,095,124 B2	1/2012	Balia
			8,095,640 B2	1/2012	Guingo et al.

(56)

References Cited

U.S. PATENT DOCUMENTS

8,095,666 B2	1/2012	Schmidt et al.	8,208,919 B2	6/2012	Kotecha
8,098,579 B2	1/2012	Ray et al.	8,213,296 B2	7/2012	Shannon et al.
8,099,077 B2	1/2012	Chowdhury et al.	8,213,363 B2	7/2012	Ying et al.
8,099,517 B2	1/2012	Jia et al.	8,214,536 B2	7/2012	Zhao
8,102,814 B2	1/2012	Rahman et al.	8,223,741 B1	7/2012	Bartlett et al.
8,103,285 B2	1/2012	Kalhan	8,224,382 B2	7/2012	Bultman
8,104,080 B2*	1/2012	Burns G06F 9/44505 705/51	8,224,773 B2	7/2012	Spiegel
8,107,953 B2	1/2012	Zimmerman et al.	8,228,818 B2	7/2012	Chase et al.
8,108,520 B2	1/2012	Ruutu et al.	8,229,394 B2	7/2012	Karlberg
8,112,435 B2	2/2012	Epstein et al.	8,229,914 B2	7/2012	Ramer et al.
8,116,223 B2	2/2012	Tian et al.	8,233,433 B2	7/2012	Kalhan
8,116,749 B2	2/2012	Proctor, Jr. et al.	8,233,883 B2	7/2012	De Froment
8,116,781 B2	2/2012	Chen et al.	8,233,895 B2	7/2012	Tysowski
8,122,128 B2	2/2012	Burke, II et al.	8,238,287 B1	8/2012	Gopi et al.
8,122,249 B2	2/2012	Falk et al.	8,239,520 B2	8/2012	Grah
8,126,123 B2	2/2012	Cai et al.	8,242,959 B2	8/2012	Mia et al.
8,126,396 B2	2/2012	Bennett	8,244,241 B2	8/2012	Montemurro
8,126,476 B2	2/2012	Vardi et al.	8,249,601 B2	8/2012	Emberson et al.
8,126,722 B2	2/2012	Robb et al.	8,254,880 B2	8/2012	Aaltonen et al.
8,130,793 B2	3/2012	Edwards et al.	8,254,915 B2	8/2012	Kozisek
8,131,256 B2	3/2012	Martti et al.	8,255,515 B1	8/2012	Melman et al.
8,131,281 B1	3/2012	Hildner et al.	8,255,534 B2	8/2012	Assadzadeh
8,134,954 B2	3/2012	Godfrey et al.	8,255,689 B2	8/2012	Kim et al.
8,135,388 B1	3/2012	Gailloux et al.	8,259,692 B2	9/2012	Bajko
8,135,392 B2	3/2012	Marcellino et al.	8,264,965 B2	9/2012	Dolganow et al.
8,135,657 B2	3/2012	Kapoor et al.	8,265,004 B2	9/2012	Toutonghi
8,144,591 B2	3/2012	Ghai et al.	8,266,681 B2	9/2012	Deshpande et al.
8,149,823 B2	4/2012	Turcan et al.	8,270,955 B2	9/2012	Ramer et al.
8,150,394 B2*	4/2012	Bianconi H04W 8/20 370/352	8,270,972 B2	9/2012	Otting et al.
8,150,431 B2	4/2012	Wolovitz et al.	8,271,045 B2	9/2012	Parolkar et al.
8,155,155 B1	4/2012	Chow et al.	8,271,049 B2	9/2012	Silver et al.
8,155,620 B2	4/2012	Wang et al.	8,271,992 B2	9/2012	Chatley et al.
8,155,666 B2	4/2012	Alizadeh-Shabdziz	8,275,415 B2	9/2012	Huslak
8,155,670 B2	4/2012	Fullam et al.	8,279,067 B2	10/2012	Berger et al.
8,156,206 B2	4/2012	Kiley et al.	8,279,864 B2	10/2012	Wood
8,160,015 B2	4/2012	Rashid et al.	8,280,354 B2	10/2012	Smith et al.
8,160,598 B2	4/2012	Savoor	8,284,740 B2	10/2012	O'Connor
8,165,576 B2	4/2012	Raju et al.	8,285,249 B2	10/2012	Baker et al.
8,166,040 B2	4/2012	Brindisi et al.	8,291,238 B2	10/2012	Ginter et al.
8,166,554 B2*	4/2012	John H04L 63/105 726/26	8,296,404 B2	10/2012	McDysan et al.
8,170,553 B2	5/2012	Bennett	8,300,575 B2	10/2012	Willars
8,174,378 B2	5/2012	Richman et al.	8,306,518 B1	11/2012	Gailloux et al.
8,174,970 B2	5/2012	Adamczyk et al.	8,307,067 B2	11/2012	Ryan
8,175,574 B1	5/2012	Panda et al.	8,315,593 B2	11/2012	Gallant et al.
8,180,881 B2	5/2012	Seo et al.	8,315,594 B1	11/2012	Mausser et al.
8,180,886 B2	5/2012	Overcash et al.	8,315,718 B2	11/2012	Caffrey et al.
8,184,530 B1	5/2012	Swan et al.	8,315,999 B2	11/2012	Chatley et al.
8,184,590 B2	5/2012	Rosenblatt	8,320,244 B2	11/2012	Muqattash et al.
8,185,088 B2	5/2012	Klein et al.	8,320,949 B2	11/2012	Matta
8,185,093 B2	5/2012	Jheng et al.	8,325,638 B2	12/2012	Jin et al.
8,185,127 B1	5/2012	Cai et al.	8,326,319 B2	12/2012	Davis
8,185,152 B1	5/2012	Goldner	8,326,828 B2	12/2012	Zhou et al.
8,185,158 B2	5/2012	Tamura et al.	8,331,223 B2	12/2012	Hill et al.
8,190,122 B1	5/2012	Alexander et al.	8,331,293 B2	12/2012	Sood
8,190,675 B2	5/2012	Tribbett	8,332,375 B2	12/2012	Chatley et al.
8,191,116 B1	5/2012	Gazzard	8,339,991 B2	12/2012	Biswas et al.
8,191,124 B2	5/2012	Wynn et al.	8,340,718 B2	12/2012	Colonna et al.
8,194,549 B2	6/2012	Huber et al.	8,346,210 B2	1/2013	Balsan et al.
8,194,553 B2	6/2012	Liang et al.	8,347,104 B2	1/2013	Pathiyal
8,194,572 B2	6/2012	Horvath et al.	8,347,362 B2	1/2013	Cai et al.
8,195,093 B2	6/2012	Garrett et al.	8,347,378 B2	1/2013	Merkin et al.
8,195,163 B2	6/2012	Gisby et al.	8,350,700 B2	1/2013	Fast et al.
8,195,661 B2	6/2012	Kalavade	8,351,592 B2	1/2013	Freeny, Jr. et al.
8,196,199 B2	6/2012	Hrastar et al.	8,351,898 B2	1/2013	Raleigh
8,200,163 B2	6/2012	Hoffman	8,352,360 B2	1/2013	De Judicibus et al.
8,200,200 B1	6/2012	Belser et al.	8,352,980 B2	1/2013	Howcroft
8,200,509 B2	6/2012	Kenedy et al.	8,353,001 B2	1/2013	Herrod
8,200,775 B2	6/2012	Moore	8,355,696 B1	1/2013	Olding et al.
8,200,818 B2	6/2012	Freund et al.	8,356,336 B2	1/2013	Johnston et al.
8,204,190 B2	6/2012	Bang et al.	8,358,638 B2	1/2013	Scherzer et al.
8,204,505 B2	6/2012	Jin et al.	8,358,975 B2	1/2013	Bahl et al.
8,208,788 B2	6/2012	Ando et al.	8,363,658 B1	1/2013	Delker et al.
			8,364,089 B2	1/2013	Phillips
			8,364,806 B2	1/2013	Short et al.
			8,369,274 B2	2/2013	Sawai
			8,370,477 B2	2/2013	Short et al.
			8,370,483 B2	2/2013	Choong et al.
			8,374,090 B2	2/2013	Morrill et al.
			8,374,592 B2	2/2013	Proctor, Jr. et al.

(56)

References Cited

U.S. PATENT DOCUMENTS

8,375,128 B2	2/2013	Tofighbakhsh et al.	8,634,425 B2	1/2014	Gorti et al.	
8,375,136 B2	2/2013	Roman et al.	8,635,164 B2	1/2014	Rosenhaft et al.	
8,385,896 B2	2/2013	Proctor, Jr. et al.	8,644,702 B1	2/2014	Kalajan	
8,385,975 B2	2/2013	Forutanpour et al.	8,644,813 B1	2/2014	Gailloux et al.	
8,386,386 B1	2/2013	Zhu	8,645,518 B2	2/2014	David	
8,391,262 B2	3/2013	Maki et al.	8,655,357 B1	2/2014	Gazzard et al.	
8,396,458 B2	3/2013	Raleigh	8,660,853 B2	2/2014	Robb et al.	
8,396,929 B2	3/2013	Helfman et al.	8,666,395 B2	3/2014	Silver	
8,402,540 B2	3/2013	Kapoor et al.	8,667,542 B1*	3/2014	Bertz	H04L 51/20 725/32
8,406,427 B2	3/2013	Chand et al.	8,670,334 B2	3/2014	Keohane et al.	
8,406,736 B2	3/2013	Das et al.	8,676,925 B1	3/2014	Liu et al.	
8,411,587 B2	4/2013	Curtis et al.	8,693,323 B1	4/2014	McDysan	
8,411,691 B2	4/2013	Aggarwal	8,694,772 B2	4/2014	Kao et al.	
8,422,988 B1	4/2013	Keshav	8,701,015 B2	4/2014	Bonnat	
8,423,016 B2	4/2013	Buckley et al.	8,705,361 B2	4/2014	Venkataraman et al.	
8,429,403 B2	4/2013	Moret et al.	8,706,863 B2	4/2014	Fadell	
8,437,734 B2	5/2013	Ray et al.	8,713,535 B2	4/2014	Malhotra et al.	
8,442,015 B2	5/2013	Behzad et al.	8,713,641 B1	4/2014	Pagan et al.	
8,447,324 B2	5/2013	Shuman et al.	8,719,423 B2	5/2014	Wylid	
8,447,607 B2	5/2013	Weider et al.	8,725,899 B2	5/2014	Short et al.	
8,447,980 B2	5/2013	Godfrey et al.	8,730,842 B2	5/2014	Collins et al.	
8,452,858 B2	5/2013	Wu et al.	8,732,808 B2	5/2014	Sewall et al.	
8,461,958 B2	6/2013	Saenz et al.	8,739,035 B2	5/2014	Trethewey	
8,463,232 B2	6/2013	Tuli et al.	8,761,711 B2	6/2014	Grignani et al.	
8,468,337 B2	6/2013	Gaur et al.	8,780,857 B2	7/2014	Balasubramanian et al.	
8,472,371 B1	6/2013	Bari et al.	8,793,304 B2*	7/2014	Lu	H04L 63/101 340/1.1
8,477,778 B2	7/2013	Lehmann, Jr. et al.	8,811,991 B2	8/2014	Jain et al.	
8,483,135 B2	7/2013	Cai et al.	8,825,109 B2	9/2014	Montemurro et al.	
8,483,694 B2	7/2013	Lewis et al.	8,831,561 B2	9/2014	Sutaria et al.	
8,484,327 B2	7/2013	Werner et al.	8,880,047 B2	11/2014	Konicek et al.	
8,488,597 B2	7/2013	Nie et al.	8,930,238 B2	1/2015	Coffman et al.	
8,489,110 B2	7/2013	Frank et al.	8,948,726 B2*	2/2015	Smith	H04W 8/183 455/406
8,489,720 B1	7/2013	Morford et al.	8,949,597 B1	2/2015	Reeves et al.	
8,495,181 B2	7/2013	Venkataraman et al.	8,966,018 B2	2/2015	Bugwadia et al.	
8,495,227 B2	7/2013	Kaminsky et al.	8,977,284 B2	3/2015	Reed	
8,495,360 B2	7/2013	Falk et al.	9,002,342 B2	4/2015	Tenhunen et al.	
8,495,700 B2	7/2013	Shahbazi	9,014,973 B2	4/2015	Ruckart	
RE44,412 E	8/2013	Naqvi et al.	9,049,010 B2	6/2015	Jueneman et al.	
8,503,455 B2	8/2013	Heikens	2001/0048738 A1	12/2001	Baniak et al.	
8,504,729 B2	8/2013	Pezzutti	2001/0053694 A1	12/2001	Igarashi et al.	
8,509,082 B2	8/2013	Heinz et al.	2002/0022472 A1	2/2002	Watler et al.	
8,514,927 B2	8/2013	Sundararajan et al.	2002/0049074 A1	4/2002	Eisinger et al.	
8,516,552 B2	8/2013	Raleigh	2002/0116338 A1	8/2002	Gonthier et al.	
8,520,589 B2	8/2013	Bhatt et al.	2002/0120540 A1	8/2002	Kende et al.	
8,521,110 B2	8/2013	Rofougaran	2002/0131404 A1	9/2002	Mehta et al.	
8,522,039 B2	8/2013	Hyndman et al.	2002/0138601 A1	9/2002	Piponius et al.	
8,522,249 B2	8/2013	Beaule	2002/0154751 A1	10/2002	Thompson et al.	
8,522,337 B2	8/2013	Adusumilli et al.	2002/0161601 A1	10/2002	Nauer et al.	
8,526,329 B2	9/2013	Mahany et al.	2002/0164983 A1	11/2002	Raviv et al.	
8,526,350 B2	9/2013	Xue et al.	2002/0176377 A1	11/2002	Hamilton	
8,527,410 B2	9/2013	Markki et al.	2002/0188732 A1	12/2002	Buckman et al.	
8,527,662 B2	9/2013	Biswas et al.	2002/0191573 A1	12/2002	Whitehill et al.	
8,528,068 B1	9/2013	Weglein et al.	2002/0199001 A1	12/2002	Wenocur et al.	
8,532,610 B2	9/2013	Manning Cassett et al.	2003/0004937 A1	1/2003	Salmenkaita et al.	
8,533,775 B2	9/2013	Alcorn et al.	2003/0005112 A1	1/2003	Krautkremer	
8,538,394 B2	9/2013	Zimmerman et al.	2003/0013434 A1	1/2003	Rosenberg et al.	
8,538,458 B2	9/2013	Haney	2003/0018524 A1	1/2003	Fishman et al.	
8,543,265 B2	9/2013	Ekhaguere et al.	2003/0046396 A1	3/2003	Richter et al.	
8,544,105 B2	9/2013	Mclean et al.	2003/0050070 A1	3/2003	Mashinsky et al.	
8,548,427 B2	10/2013	Chow et al.	2003/0050837 A1	3/2003	Kim	
8,554,876 B2	10/2013	Winsor	2003/0084321 A1	5/2003	Tarquini et al.	
8,561,138 B2	10/2013	Rothman et al.	2003/0088671 A1	5/2003	Klinker et al.	
8,565,746 B2	10/2013	Hoffman	2003/0133408 A1	7/2003	Cheng et al.	
8,566,236 B2	10/2013	Busch	2003/0161265 A1	8/2003	Cao et al.	
8,571,474 B2	10/2013	Chavez et al.	2003/0171112 A1	9/2003	Lupper et al.	
8,571,501 B2	10/2013	Miller et al.	2003/0182420 A1	9/2003	Jones et al.	
8,571,598 B2	10/2013	Valavi	2003/0182435 A1	9/2003	Redlich et al.	
8,571,993 B2	10/2013	Kocher et al.	2003/0188006 A1	10/2003	Bard	
8,572,117 B2	10/2013	Rappaport	2003/0188117 A1	10/2003	Yoshino et al.	
8,572,256 B2	10/2013	Babbar	2003/0220984 A1	11/2003	Jones et al.	
8,583,499 B2	11/2013	De Judicibus et al.	2003/0224781 A1	12/2003	Milford et al.	
8,589,955 B2	11/2013	Roundtree et al.	2003/0229900 A1	12/2003	Reisman	
8,601,125 B2	12/2013	Huang et al.	2003/0233332 A1	12/2003	Keeler et al.	
8,605,691 B2	12/2013	Soomro et al.	2003/0236745 A1	12/2003	Hartsell et al.	
8,631,428 B2	1/2014	Scott et al.	2004/0019539 A1	1/2004	Raman et al.	
			2004/0021697 A1	2/2004	Beaton et al.	

(56)

References Cited

U.S. PATENT DOCUMENTS

2004/0030705	A1	2/2004	Bowman-Amuah	2006/0143066	A1	6/2006	Calabria
2004/0039792	A1	2/2004	Nakanishi	2006/0143098	A1	6/2006	Lazaridis
2004/0044623	A1	3/2004	Wake et al.	2006/0156398	A1	7/2006	Ross et al.
2004/0047358	A1	3/2004	Chen et al.	2006/0160536	A1	7/2006	Chou
2004/0073672	A1	4/2004	Fascenda	2006/0165060	A1	7/2006	Dua
2004/0082346	A1	4/2004	Skytt et al.	2006/0168128	A1	7/2006	Sistla et al.
2004/0098715	A1	5/2004	Aghera et al.	2006/0173959	A1	8/2006	Mckelvie et al.
2004/0102182	A1	5/2004	Reith et al.	2006/0174035	A1	8/2006	Tufail
2004/0103193	A1	5/2004	Pandya et al.	2006/0178917	A1	8/2006	Merriam et al.
2004/0107360	A1	6/2004	Herrmann et al.	2006/0178918	A1	8/2006	Mikurak
2004/0127200	A1	7/2004	Shaw et al.	2006/0183462	A1	8/2006	Kolehmainen
2004/0132427	A1	7/2004	Lee et al.	2006/0190314	A1	8/2006	Hernandez
2004/0133668	A1	7/2004	Nicholas, III	2006/0199608	A1	9/2006	Dunn et al.
2004/0137890	A1	7/2004	Kalke	2006/0206709	A1	9/2006	Labrou et al.
2004/0168052	A1	8/2004	Clisham et al.	2006/0206904	A1	9/2006	Watkins et al.
2004/0170191	A1	9/2004	Guo et al.	2006/0218395	A1	9/2006	Maes
2004/0198331	A1	10/2004	Coward et al.	2006/0233108	A1	10/2006	Krishnan
2004/0203755	A1	10/2004	Brunet et al.	2006/0233166	A1	10/2006	Bou-Diab et al.
2004/0203833	A1	10/2004	Rathunde et al.	2006/0236095	A1	10/2006	Smith et al.
2004/0225898	A1	11/2004	Frost et al.	2006/0242685	A1	10/2006	Heard et al.
2004/0236547	A1	11/2004	Rappaport et al.	2006/0258341	A1	11/2006	Miller et al.
2004/0243992	A1	12/2004	Gustafson et al.	2006/0291477	A1	12/2006	Croak et al.
2004/0249918	A1	12/2004	Sunshine	2007/0005795	A1	1/2007	Gonzalez
2004/0255145	A1	12/2004	Chow	2007/0019670	A1	1/2007	Falardeau
2004/0259534	A1	12/2004	Chaudhari et al.	2007/0022289	A1	1/2007	Alt et al.
2004/0260766	A1	12/2004	Barros et al.	2007/0025301	A1	2/2007	Petersson et al.
2005/0007993	A1	1/2005	Chambers et al.	2007/0033194	A1	2/2007	Srinivas et al.
2005/0009499	A1	1/2005	Koster	2007/0033197	A1	2/2007	Scherzer et al.
2005/0021995	A1	1/2005	Lal et al.	2007/0036312	A1	2/2007	Cai et al.
2005/0041617	A1	2/2005	Huotari et al.	2007/0055694	A1	3/2007	Ruge et al.
2005/0048950	A1	3/2005	Morper	2007/0060200	A1	3/2007	Boris et al.
2005/0055291	A1	3/2005	Bevente et al.	2007/0061243	A1	3/2007	Ramer et al.
2005/0055309	A1	3/2005	Williams et al.	2007/0061878	A1	3/2007	Hagiu et al.
2005/0055595	A1	3/2005	Frazier et al.	2007/0073899	A1	3/2007	Judge et al.
2005/0060266	A1	3/2005	DeMello et al.	2007/0076616	A1	4/2007	Ngo et al.
2005/0075115	A1	4/2005	Corneille et al.	2007/0093243	A1	4/2007	Kapadekar et al.
2005/0079863	A1	4/2005	Macaluso	2007/0100981	A1	5/2007	Adamczyk et al.
2005/0097516	A1	5/2005	Donnelly et al.	2007/0101426	A1	5/2007	Lee et al.
2005/0107091	A1	5/2005	Vannithamby et al.	2007/0104126	A1	5/2007	Calhoun et al.
2005/0128967	A1	6/2005	Scobbie	2007/0109983	A1	5/2007	Shankar et al.
2005/0135264	A1	6/2005	Popoff et al.	2007/0130315	A1	6/2007	Friend et al.
2005/0166043	A1	7/2005	Zhang et al.	2007/0140113	A1	6/2007	Gemelos
2005/0183143	A1	8/2005	Anderholm et al.	2007/0140145	A1	6/2007	Kumar et al.
2005/0186948	A1	8/2005	Gallagher et al.	2007/0140275	A1	6/2007	Bowman et al.
2005/0198377	A1	9/2005	Ferguson et al.	2007/0143824	A1	6/2007	Shahbazi
2005/0216421	A1	9/2005	Barry et al.	2007/0147317	A1	6/2007	Smith et al.
2005/0228985	A1	10/2005	Ylikoski et al.	2007/0147324	A1	6/2007	McGary
2005/0238046	A1	10/2005	Hassan et al.	2007/0155365	A1	7/2007	Kim et al.
2005/0239447	A1	10/2005	Holzman et al.	2007/0165630	A1	7/2007	Rasanen et al.
2005/0245241	A1	11/2005	Durand et al.	2007/0168499	A1	7/2007	Chu
2005/0246282	A1	11/2005	Naslund et al.	2007/0174490	A1	7/2007	Choi et al.
2005/0250508	A1	11/2005	Guo et al.	2007/0192460	A1	8/2007	Choi et al.
2005/0250536	A1	11/2005	Deng et al.	2007/0198656	A1	8/2007	Mazzaferrri et al.
2005/0254435	A1	11/2005	Moakley et al.	2007/0213054	A1	9/2007	Han
2005/0266825	A1	12/2005	Clayton	2007/0220251	A1	9/2007	Rosenberg et al.
2005/0266880	A1	12/2005	Gupta et al.	2007/0226225	A1	9/2007	Yiu et al.
2006/0014519	A1	1/2006	Marsh et al.	2007/0226775	A1	9/2007	Andreasen et al.
2006/0019632	A1	1/2006	Cunningham et al.	2007/0234402	A1	10/2007	Khosravi et al.
2006/0026679	A1	2/2006	Zakas	2007/0243862	A1	10/2007	Coskun et al.
2006/0030306	A1	2/2006	Kuhn	2007/0248100	A1	10/2007	Zuberi et al.
2006/0034256	A1	2/2006	Addagatla et al.	2007/0254675	A1	11/2007	Zorlu Ozer et al.
2006/0035631	A1	2/2006	White et al.	2007/0255848	A1	11/2007	Sewall et al.
2006/0040642	A1	2/2006	Boris et al.	2007/0259656	A1	11/2007	Jeong
2006/0045245	A1	3/2006	Aaron et al.	2007/0259673	A1	11/2007	Willars et al.
2006/0048223	A1	3/2006	Lee et al.	2007/0263558	A1	11/2007	Salomone
2006/0068796	A1	3/2006	Millen et al.	2007/0266422	A1	11/2007	Germano et al.
2006/0072451	A1	4/2006	Ross	2007/0274327	A1	11/2007	Kaarela et al.
2006/0072646	A1	4/2006	Fehér	2007/0280453	A1	12/2007	Kelley et al.
2006/0085543	A1	4/2006	Hrastar et al.	2007/0282896	A1	12/2007	Wydroug et al.
2006/0095517	A1	5/2006	O'Connor et al.	2007/0293191	A1	12/2007	Mir et al.
2006/0098627	A1	5/2006	Karaoguz et al.	2007/0294395	A1	12/2007	Strub et al.
2006/0112016	A1	5/2006	Ishibashi	2007/0294410	A1	12/2007	Pandya et al.
2006/0114832	A1	6/2006	Hamilton et al.	2007/0298764	A1	12/2007	Clayton
2006/0135144	A1	6/2006	Jothipragasam	2007/0300252	A1	12/2007	Acharya et al.
2006/0136882	A1	6/2006	Noonan et al.	2008/0005285	A1	1/2008	Robinson et al.
				2008/0005561	A1	1/2008	Brown et al.
				2008/0010379	A1	1/2008	Zhao
				2008/0010452	A1	1/2008	Holtzman et al.
				2008/0018494	A1	1/2008	Waite et al.

(56)

References Cited

U.S. PATENT DOCUMENTS

2008/0022354	A1	1/2008	Grewal et al.	2008/0313730	A1	12/2008	Iftimie et al.
2008/0025230	A1	1/2008	Patel et al.	2008/0316923	A1	12/2008	Fedders et al.
2008/0032715	A1	2/2008	Jia et al.	2008/0318547	A1	12/2008	Ballou et al.
2008/0034063	A1	2/2008	Yee	2008/0318550	A1	12/2008	DeAtley
2008/0034419	A1	2/2008	Mullick et al.	2008/0319879	A1	12/2008	Carroll et al.
2008/0039102	A1	2/2008	Sewall et al.	2009/0005000	A1	1/2009	Baker et al.
2008/0049630	A1	2/2008	Kozisek et al.	2009/0005005	A1	1/2009	Forstall et al.
2008/0050715	A1	2/2008	Golczewski et al.	2009/0006116	A1	1/2009	Baker et al.
2008/0051076	A1	2/2008	O'Shaughnessy et al.	2009/0006200	A1	1/2009	Baker et al.
2008/0052387	A1	2/2008	Heinz et al.	2009/0013157	A1	1/2009	Beaule
2008/0056273	A1	3/2008	Pelletier et al.	2009/0044185	A1	2/2009	Krivopaltsev
2008/0059474	A1	3/2008	Lim	2009/0046707	A1	2/2009	Smires et al.
2008/0059743	A1	3/2008	Bychkov et al.	2009/0046723	A1	2/2009	Rahman et al.
2008/0060066	A1	3/2008	Wynn et al.	2009/0048913	A1	2/2009	Shenfield et al.
2008/0062900	A1	3/2008	Rao	2009/0049518	A1	2/2009	Roman et al.
2008/0064367	A1	3/2008	Nath et al.	2009/0054030	A1	2/2009	Golds
2008/0066149	A1	3/2008	Lim	2009/0067372	A1	3/2009	Shah et al.
2008/0066150	A1	3/2008	Lim	2009/0068984	A1	3/2009	Burnett
2008/0070550	A1	3/2008	Hose	2009/0070379	A1	3/2009	Rappaport
2008/0080457	A1	4/2008	Cole	2009/0077622	A1	3/2009	Baum et al.
2008/0081606	A1	4/2008	Cole	2009/0079699	A1	3/2009	Sun
2008/0082643	A1	4/2008	Storrie et al.	2009/0113514	A1	4/2009	Hu
2008/0083013	A1	4/2008	Soliman et al.	2009/0125619	A1	5/2009	Antani
2008/0085707	A1	4/2008	Fadell	2009/0157792	A1	6/2009	Fiatal
2008/0089295	A1	4/2008	Keeler et al.	2009/0163173	A1	6/2009	Williams
2008/0095339	A1	4/2008	Elliott et al.	2009/0172077	A1	7/2009	Roxburgh et al.
2008/0098062	A1	4/2008	Balia	2009/0180391	A1	7/2009	Petersen et al.
2008/0109679	A1	5/2008	Wright et al.	2009/0181662	A1	7/2009	Fleischman et al.
2008/0120129	A1	5/2008	Seubert et al.	2009/0197585	A1	8/2009	Aaron
2008/0120668	A1	5/2008	Yau	2009/0197612	A1	8/2009	Kiiskinen
2008/0120688	A1	5/2008	Qiu et al.	2009/0219170	A1	9/2009	Clark et al.
2008/0125079	A1	5/2008	O'Neil et al.	2009/0248883	A1	10/2009	Suryanarayana et al.
2008/0127304	A1	5/2008	Ginter et al.	2009/0254857	A1	10/2009	Romine et al.
2008/0130534	A1	6/2008	Tomiooka	2009/0257379	A1	10/2009	Robinson et al.
2008/0130656	A1	6/2008	Kim et al.	2009/0271514	A1	10/2009	Thomas et al.
2008/0132201	A1	6/2008	Karlberg	2009/0282127	A1	11/2009	Leblanc et al.
2008/0132268	A1	6/2008	Choi-Grogan et al.	2009/0286507	A1	11/2009	O'Neil et al.
2008/0134330	A1	6/2008	Kapoor et al.	2009/0287921	A1	11/2009	Zhu et al.
2008/0139210	A1	6/2008	Gisby et al.	2009/0288140	A1	11/2009	Huber et al.
2008/0147454	A1	6/2008	Walker et al.	2009/0299857	A1	12/2009	Brubaker
2008/0160958	A1	7/2008	Abichandani et al.	2009/0307746	A1	12/2009	Di et al.
2008/0162637	A1	7/2008	Adamczyk et al.	2009/0315735	A1	12/2009	Bhavani et al.
2008/0162704	A1	7/2008	Poplett et al.	2010/0017506	A1	1/2010	Fadell
2008/0164304	A1	7/2008	Narasimhan et al.	2010/0020822	A1	1/2010	Zerillo et al.
2008/0166993	A1	7/2008	Gautier et al.	2010/0027469	A1	2/2010	Gurajala et al.
2008/0167027	A1	7/2008	Gautier et al.	2010/0027559	A1	2/2010	Lin et al.
2008/0167033	A1	7/2008	Beckers	2010/0030890	A1	2/2010	Dutta et al.
2008/0168523	A1	7/2008	Ansari et al.	2010/0041364	A1	2/2010	Lott et al.
2008/0177998	A1	7/2008	Apsangi et al.	2010/0042675	A1	2/2010	Fujii
2008/0183812	A1	7/2008	Paul et al.	2010/0043068	A1	2/2010	Varadhan et al.
2008/0184127	A1	7/2008	Rafey et al.	2010/0071053	A1	3/2010	Ansari et al.
2008/0189760	A1	8/2008	Rosenberg et al.	2010/0075666	A1	3/2010	Garner
2008/0201266	A1	8/2008	Chua et al.	2010/0080202	A1	4/2010	Hanson
2008/0207167	A1	8/2008	Bugenhagen	2010/0082431	A1	4/2010	Ramer et al.
2008/0212470	A1	9/2008	Castaneda et al.	2010/0103820	A1	4/2010	Fuller et al.
2008/0219268	A1	9/2008	Dennison	2010/0131584	A1	5/2010	Johnson
2008/0221951	A1	9/2008	Stanforth et al.	2010/0144310	A1	6/2010	Bedingfield, Sr. et al.
2008/0222692	A1	9/2008	Andersson et al.	2010/0151866	A1	6/2010	Karpov et al.
2008/0225748	A1	9/2008	Khemani et al.	2010/0153781	A1	6/2010	Hanna
2008/0229385	A1	9/2008	Feder et al.	2010/0167696	A1	7/2010	Smith et al.
2008/0229388	A1	9/2008	Maes	2010/0188975	A1	7/2010	Raleigh
2008/0235511	A1	9/2008	O'Brien et al.	2010/0188990	A1	7/2010	Raleigh
2008/0240373	A1	10/2008	Wilhelm	2010/0188992	A1	7/2010	Raleigh
2008/0250053	A1	10/2008	Aaltonen et al.	2010/0188994	A1	7/2010	Raleigh
2008/0256593	A1	10/2008	Vinberg et al.	2010/0191576	A1	7/2010	Raleigh
2008/0262798	A1	10/2008	Kim et al.	2010/0191612	A1	7/2010	Raleigh
2008/0263348	A1	10/2008	Zaltsman et al.	2010/0191846	A1	7/2010	Raleigh
2008/0268813	A1	10/2008	Maes	2010/0192170	A1	7/2010	Raleigh
2008/0270212	A1	10/2008	Blight et al.	2010/0192212	A1	7/2010	Raleigh
2008/0282319	A1	11/2008	Fontijn et al.	2010/0195503	A1	8/2010	Raleigh
2008/0293395	A1	11/2008	Mathews et al.	2010/0197268	A1	8/2010	Raleigh
2008/0298230	A1	12/2008	Luft et al.	2010/0198698	A1	8/2010	Raleigh et al.
2008/0305793	A1	12/2008	Gallagher et al.	2010/0198939	A1	8/2010	Raleigh
2008/0311885	A1	12/2008	Dawson et al.	2010/0235329	A1	9/2010	Koren et al.
2008/0313315	A1	12/2008	Karaoguz et al.	2010/0241544	A1	9/2010	Benson et al.
				2010/0248719	A1	9/2010	Scholaert
				2010/0284327	A1	11/2010	Miklos
				2010/0287599	A1	11/2010	He et al.
				2010/0311402	A1	12/2010	Srinivasan et al.

(56)

References Cited

U.S. PATENT DOCUMENTS

2010/0325420	A1	12/2010	Kanekar
2011/0013569	A1	1/2011	Scherzer et al.
2011/0019574	A1	1/2011	Malomsoky et al.
2011/0081881	A1	4/2011	Baker et al.
2011/0082790	A1	4/2011	Baker et al.
2011/0110309	A1	5/2011	Bennett
2011/0126141	A1	5/2011	King et al.
2011/0145920	A1	6/2011	Mahaffey et al.
2011/0159818	A1	6/2011	Scherzer et al.
2011/0173678	A1	7/2011	Kaippallimalil et al.
2011/0264923	A1	10/2011	Kocher et al.
2011/0277019	A1	11/2011	Pritchard, Jr.
2012/0020296	A1	1/2012	Scherzer et al.
2012/0196644	A1	8/2012	Scherzer et al.
2012/0238287	A1	9/2012	Scherzer
2013/0029653	A1	1/2013	Baker et al.
2013/0058274	A1	3/2013	Scherzer et al.
2013/0065555	A1	3/2013	Baker et al.
2013/0084835	A1	4/2013	Scherzer et al.
2013/0144789	A1	6/2013	Aaltonen et al.
2013/0326356	A9	12/2013	Zheng et al.

FOREIGN PATENT DOCUMENTS

CN	1508734	A	6/2004
CN	1538730	A	10/2004
CN	1567818	A	1/2005
CN	101035308	A	3/2006
CN	1801829	A	7/2006
CN	1802839	A	7/2006
CN	1889777	A	7/2006
CN	101155343	A	9/2006
CN	1867024	A	11/2006
CN	1878160	A	12/2006
CN	1937511	A	3/2007
CN	101123553	A	9/2007
CN	101080055	A	11/2007
CN	101115248	A	1/2008
CN	101127988	A	2/2008
CN	101183958	A	5/2008
CN	101335666	A	12/2008
CN	101341764	A	1/2009
CN	101815275	A	8/2010
EP	1463238		9/2004
EP	1503548	A1	2/2005
EP	1739518		1/2007
EP	1772988		4/2007
EP	1850575	A1	10/2007
EP	1978772		10/2008
JP	3148713	B2	3/2001
JP	2007318354	A	12/2007
JP	2008301121	A	12/2008
JP	2009111919		5/2009
JP	2009212707	A	9/2009
JP	2009218773		9/2009
JP	2009232107	A	10/2009
WO	9858505		12/1998
WO	9927723	A1	6/1999
WO	9965185		12/1999
WO	03014891		2/2003
WO	03058880		7/2003
WO	2004028070		4/2004
WO	2004064306		7/2004
WO	2004077797		9/2004
WO	2004095753		11/2004
WO	2005008995		1/2005
WO	2006004467		1/2006
WO	2006012610	A2	2/2006
WO	2006050758		5/2006
WO	2006073837		7/2006
WO	2006077481		7/2006
WO	2006093961	A1	9/2006
WO	2006120558	A1	11/2006
WO	2006130960		12/2006

WO	2007001833	1/2007
WO	2007014630	2/2007
WO	2007018363	2/2007
WO	2007053848	5/2007
WO	2007068288	6/2007
WO	2007069245	6/2007
WO	2007097786	A 8/2007
WO	2007107701	9/2007
WO	2007124279	11/2007
WO	2007126352	11/2007
WO	2007133844	A 11/2007
WO	2008017837	2/2008
WO	2008051379	5/2008
WO	2008066419	6/2008
WO	2008080139	7/2008
WO	2008080430	7/2008
WO	2008099802	8/2008
WO	2010088413	8/2010

OTHER PUBLICATIONS

Oct. 29, 2014 Office Action in Australian Patent Application No. 2010208294.

"End to End QoS Solution for Real-time Multimedia Application;" Computer Engineering and Applications, 2007, 43 (4): 155-159, by Tan Zu-guo, Wang Wen-juan; Information and Science School, Zhanjian Normal College, Zhan jiang, Guangdong 524048, China.

"ASA/PIX: Allow Split Tunneling for VPN Clients on the ASA Configuration Example;" Document ID 70917, Jan. 10, 2008.

Ahmed et al., "A Context-Aware Vertical Handover Decision Algorithm for Multimode Mobile Terminals and Its Performance," BenQ Mobile, Munich Germany; University of Klagenfurt, Klagenfurt, Austria; 2006.

Dixon et al., Triple Play Digital Services: Comcast and Verizon (Digital Phone, Television, and Internet), Aug. 2007.

Kassar et al., "An overview of vertical handover decision strategies in heterogeneous wireless networks," ScienceDirect, University Pierre & Marie Curie, Paris, France, Jun. 5, 2007.

Sadeh et al., "Understanding and Capturing People's Privacy Policies in a Mobile Social Networking Application," ISR School of Computer Science, Carnegie Mellon University, 2007.

Schiller et al., "Location-Based Services," The Morgan Kaufmann Series in Data Management Systems, 2004.

Office Action in Chinese Patent Application No. CN 201080010511.1 dated Mar. 6, 2015.

Jun. 11, 2014 Second Office Action in Chinese Application No. 201080010511.1.

Accuris Networks, "The Business Value of Mobile Data Offload—a White Paper", 2010.

Anton, B. et al., "Best Current Practices for Wireless Internet Service Provider (WISP) Roaming"; Release Date Feb. 2003, Version 1.0; Wi-Fi Alliance—Wireless ISP Roaming (WISPr).

Ruckus Wireless—White Paper; "Smarter VVi-Fi for Mobile Operator Infrastructures" 2010.

Wireless Broadband Alliance, "WISPr 2.0, 08 Apr. 2010"; Doc. Ref. No. WBA/RM/WISPr, Version 01.00.

"Ads and movies on the run," the Gold Coast Bulletin, Southport, Qld, Jan. 29, 2008.

"Jentro Technologies launches Zenlet platform to accelerate location-based content delivery to mobile devices," The Mobile Internet, Boston, MA, Feb. 2008.

Jing et al., "Client-Server Computing in Mobile Environments," GTE Labs. Inc., Purdue University, ACM Computing Surveys, vol. 31, No. 2, Jun. 1999.

Kim, "Free wireless a high-wire act; MetroFi needs to draw enough ads to make service add profits," San Francisco Chronicle, Aug. 21, 2006.

Koutsopoulou et al., "Charging, Accounting and Billing Management Schemes in Mobile Telecommunication Networks and the Internet," IEEE Communications Surveys & Tutorials, First Quarter 2004, vol. 6, No. 1.

Loopt User Guide, metroPCS, Jul. 17, 2008.

Nuzman et al., "A compound model for TCP connection arrivals for LAN and WAN applications," Oct. 22, 2002.

(56)

References Cited

OTHER PUBLICATIONS

Richtel, "Cellphone consumerism; If even a debit card is too slow, now you have a new way to act on impulse: [National Edition]," National Post, Canada, Oct. 2, 2007.

Rivadeneira et al., "A communication architecture to access data services through GSM," San Sebastian, Spain, 1998.

Sabat, "The evolving mobile wireless value chain and market structure," Nov. 2002.

Sun et al., "Towards Connectivity Management Adaptability: Context Awareness in Policy Representation and End-to-end Evaluation Algorithm," Dept. of Electrical and Information Engineering, Univ. of Oulu, Finland, 2004.

"The Construction of Intelligent Residential District in Use of Cable Television Network," Shandong Science, vol. 13, No. 2, Jun. 2000.

VerizonWireless.com news, "Verizon Wireless Adds to Portfolio of Consumer-Friendly Tools With Introduction of Usage Controls, Usage Controls and Chaperone 2.0 Offer Parents Full Family Security Solution," Aug. 18, 2008.

Aug. 14, 2013 Office Action in Chinese Patent Application No. 201080010511.1.

3rd Generation Partnership Project, "Technical Specification Group Services and System Aspects; General Packet Radio Service (GPRS) Enhancements for Evolved Universal Terrestrial Radio Access Network (E-UTRAN) Access," Release 8, Document No. 3GPP TS 23.401, V8.4.0, Dec. 2008.

3rd Generation Partnership Project, "Technical Specification Group Services and System Aspects; Policy and Charging Control Architecture," Release 8, Document No. 3GPP TS 23.203, V8.4.0, Dec. 2008.

Alonistioti et al., "Intelligent Architectures Enabling Flexible Service Provision and Adaptability," 2002.

Amazon Technologies, Inc., "Kindle™ User's Guide," 3rd Edition, Copyright 2004-2009.

Chandrasekhar et al., "Femtocell Networks: A Survey," Jun. 28, 2008.

Chaouchi et al., "Policy Based Networking in the Integration Effort of 4G Networks and Services," 2004 IEEE.

Cisco Systems, Inc., "Cisco Mobile Exchange (CMX) Solution Guide: Chapter 2—Overview of GMS, GPRS, and UMTS," Nov. 4, 2008.

Dikaiakos et al., "A Distributed Middleware Infrastructure for Personalized Services," Nov. 24, 2003.

European Commission, "Data Roaming Tariffs—Transparency Measures," [online] retrieved from http://web.archive.org/web/20081220232754/http://ec.europa.eu/information_society/activities/roaming/data/measures/index_en.htm, Dec. 20, 2008 [retrieved May 16, 2012].

Farooq et al., "An IEEE 802.16 WiMax Module for the NS-3 Simulator," Mar. 2-6, 2009.

Han et al., "Information Collection Services for QoS-Aware Mobile Applications," 2005.

Hartmann et al., "Agent-Based Banking Transactions & Information Retrieval—What About Performance Issues?" 1999.

Hewlett-Packard Development Company, LP, "IP Multimedia Services Charging," white paper, Jan. 2006.

Hossain et al., "Gain-Based Selection of Ambient Media Services in Pervasive Environments," Mobile Networks and Applications. Oct. 3, 2008.

Knight et al., "Layer 2 and 3 Virtual Private Networks: Taxonomy, Technology, and Standardization Efforts," IEEE Communications Magazine, Jun. 2004.

Koutsopoulou et al., "Middleware Platform for the Support of Charging Reconfiguration Actions," 2005.

Kyriakakos et al., "Ubiquitous Service Provision in Next Generation Mobile Networks," Proceedings of the 13th IST Mobile and Wireless Communications Summit, Lyon, France, Jun. 2004.

Li, Yu, "Dedicated E-Reading Device: The State of the Art and The Challenges," Scroll, vol. 1, No. 1, 2008.

Nilsson et al., "A Novel MAC Scheme for Solving the QoS Parameter Adjustment Problem in IEEE802.11e EDCA," Feb. 2006.

Oppliger, Rolf, "Internet Security: Firewalls and Beyond," Communications of the ACM, May 1997, vol. 40, No. 5.

Rao et al., "Evolution of Mobile Location-Based Services," Communication of the ACM, Dec. 2003.

Steglich, Stephan, "I-Centric User Interaction," Nov. 21, 2003.

Van Eijk, et al., "GigaMobile, Agent Technology for Designing Personalized Mobile Service Brokerage," Jul. 1, 2002.

Zhu et al., "A Survey of Quality of Service in IEEE 802.11 Networks," IEEE Wireless Communications, Aug. 2004.

* cited by examiner

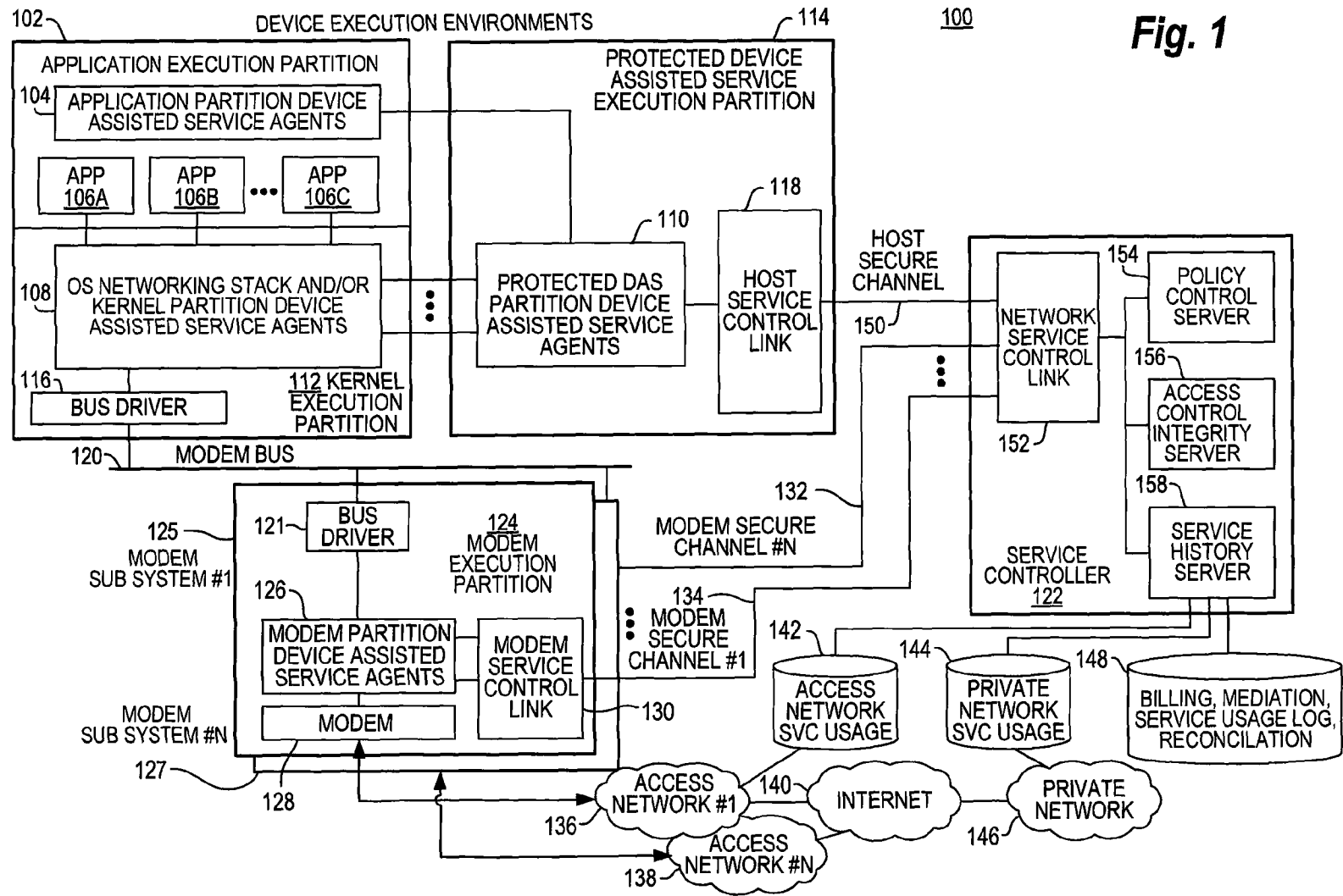
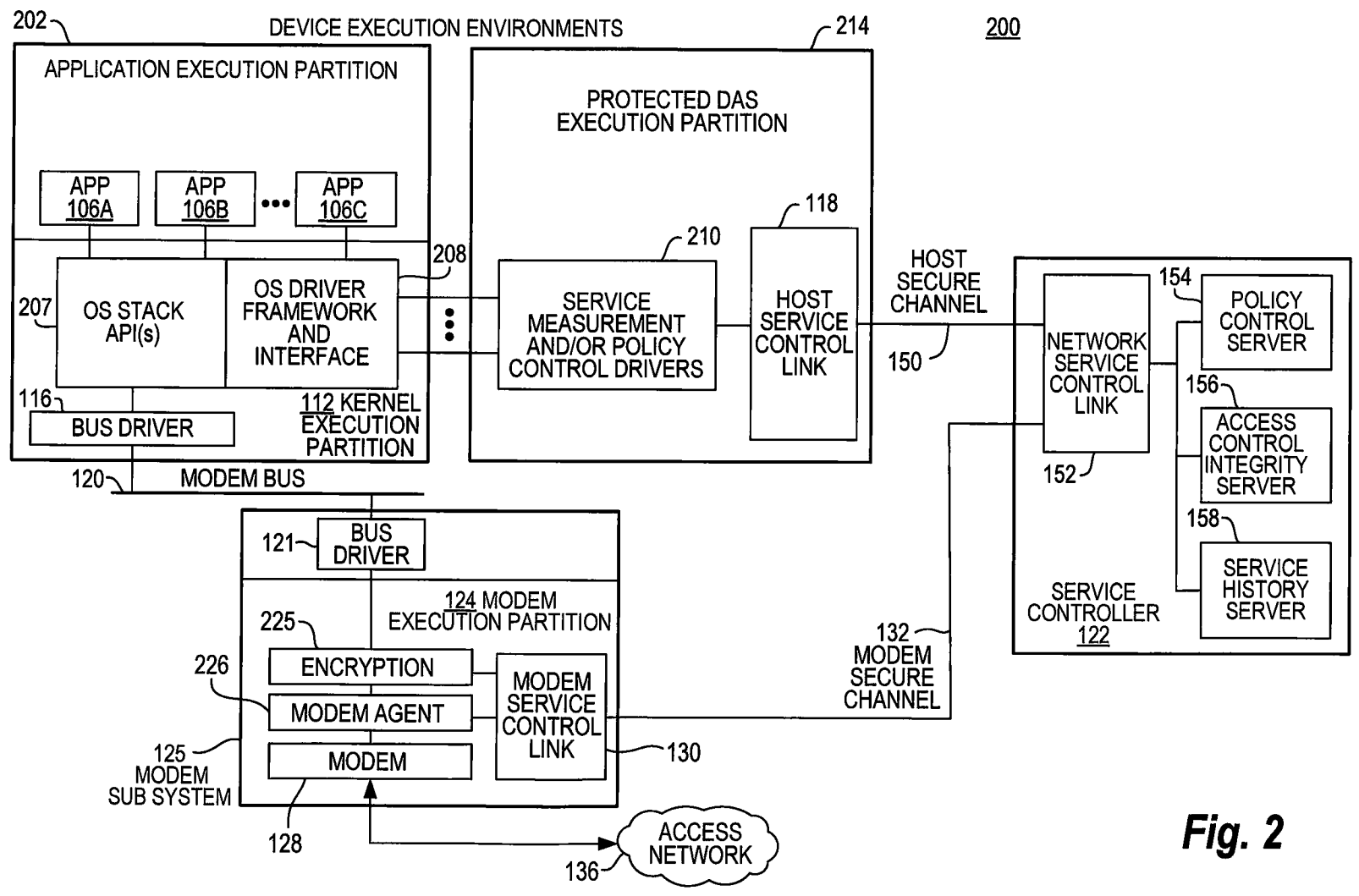

Fig. 1

11



12

Fig. 2

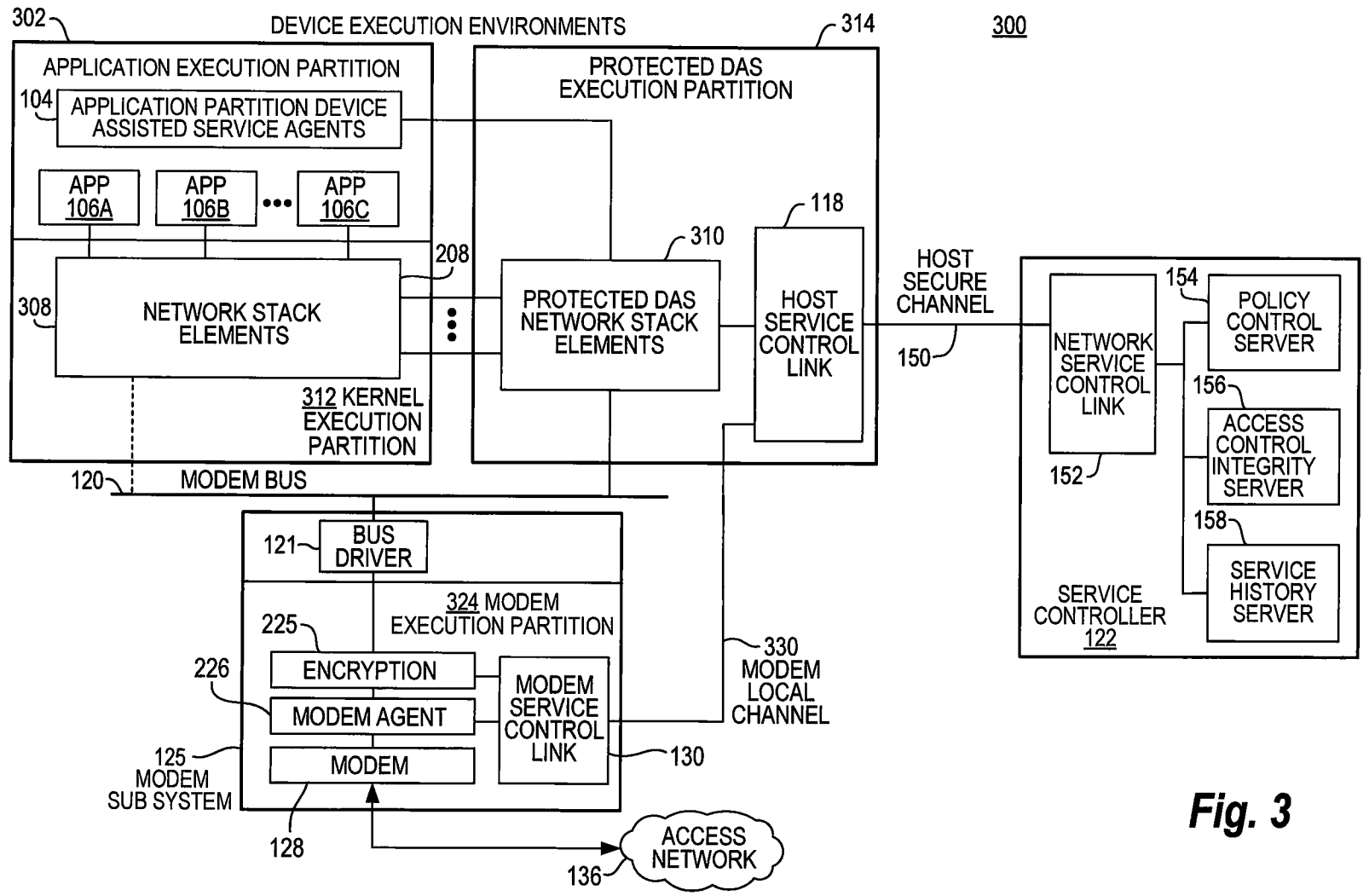
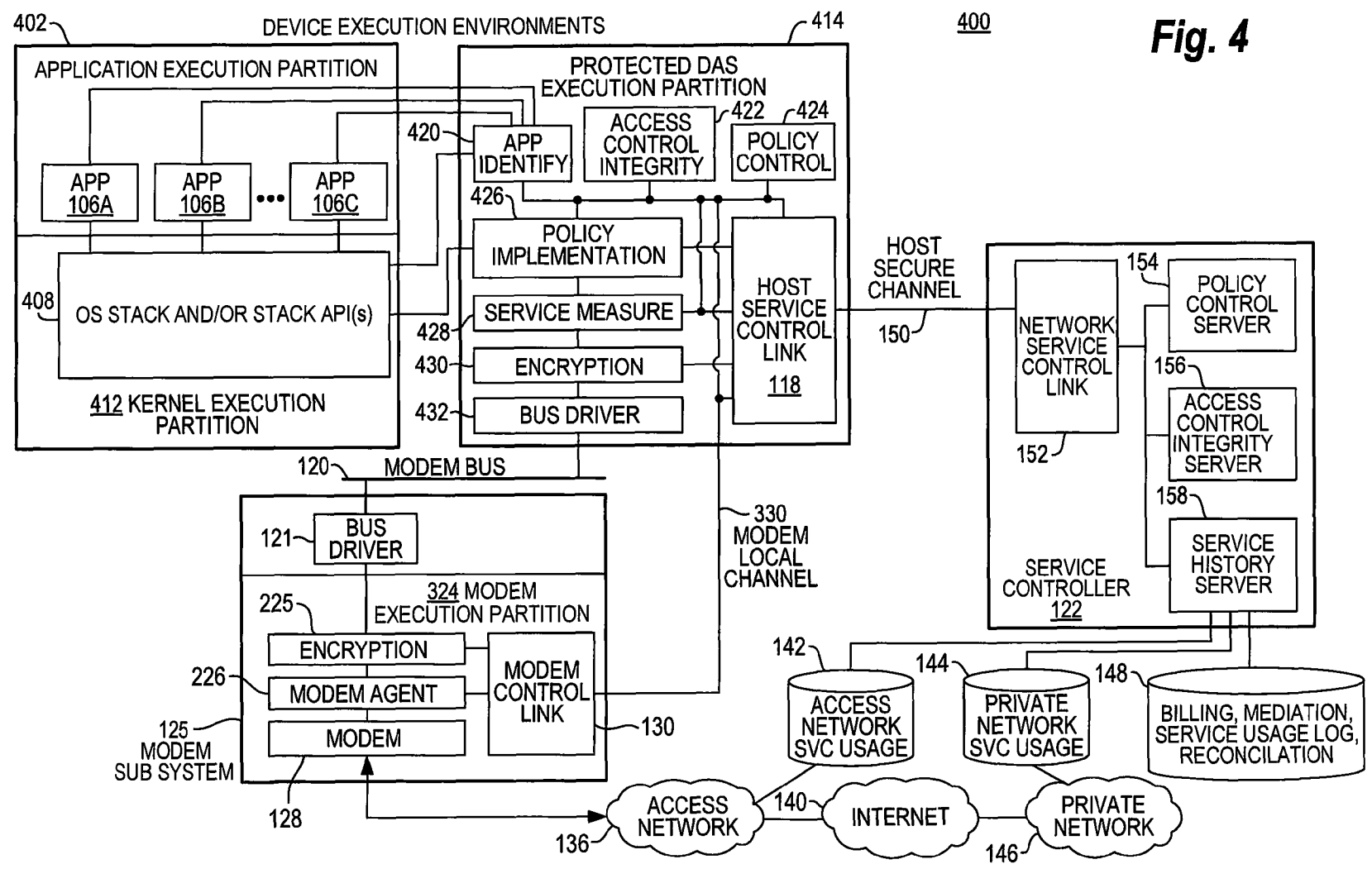

Fig. 3

Fig. 4



15

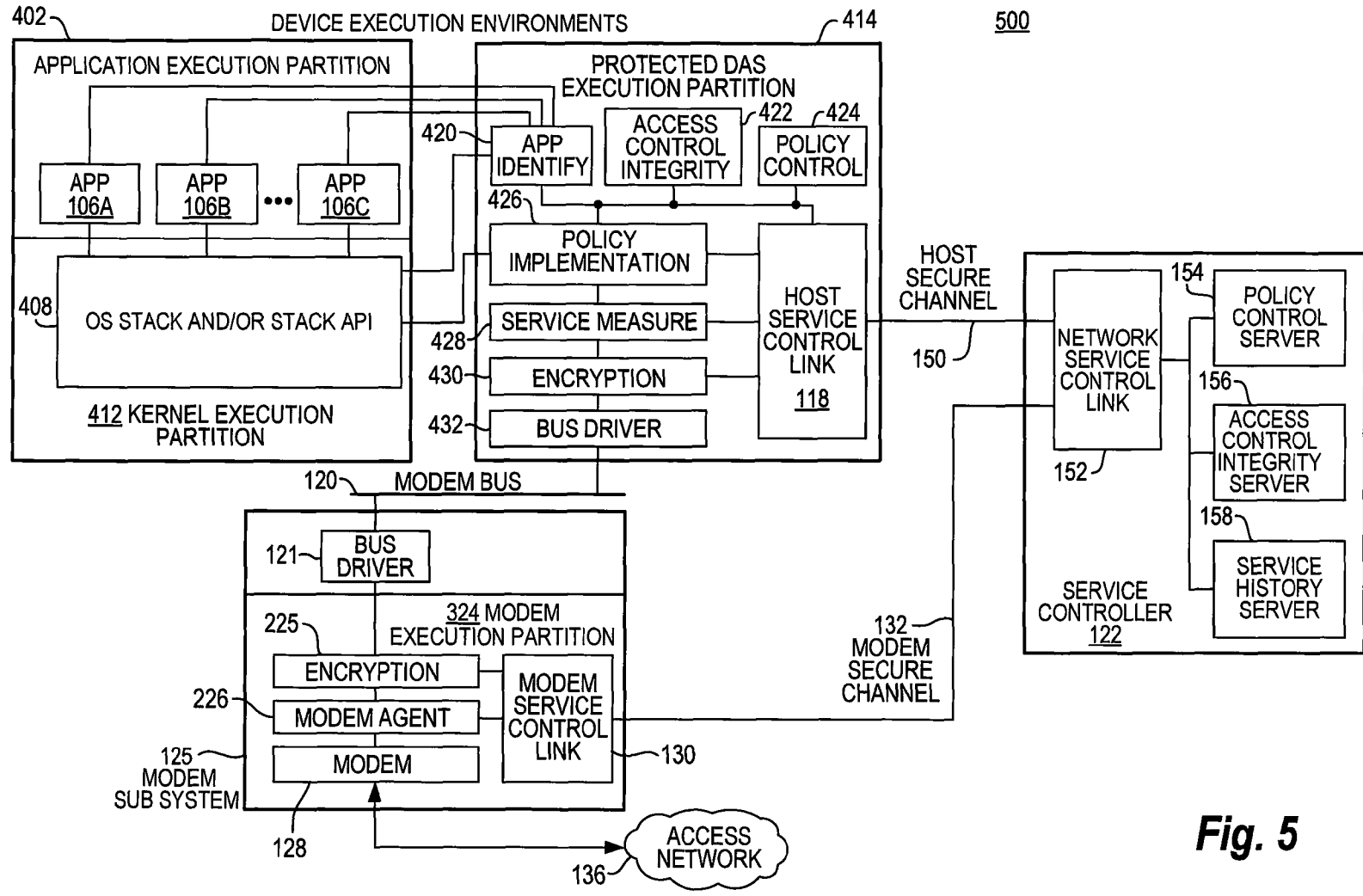

Fig. 5

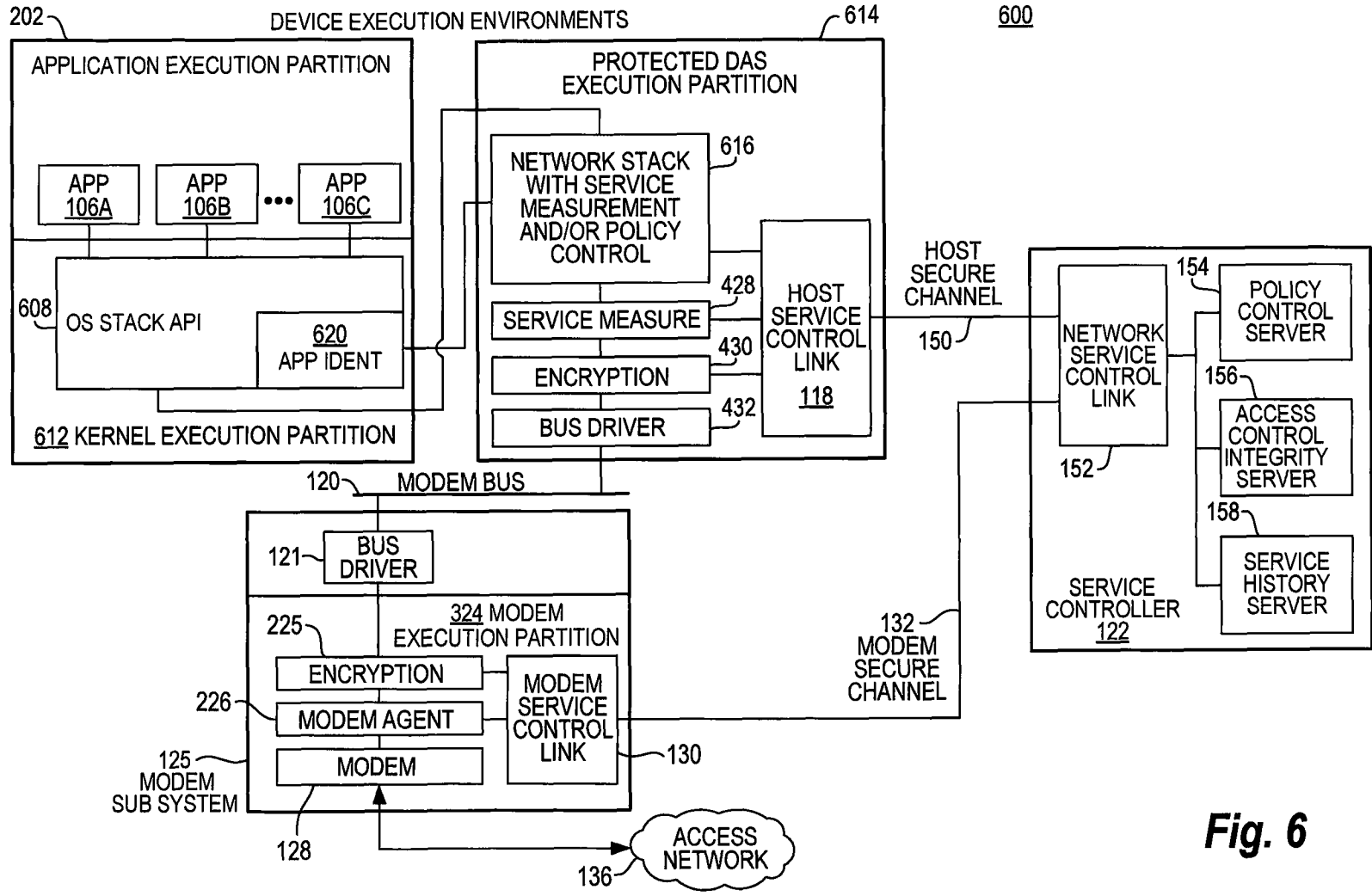

Fig. 6

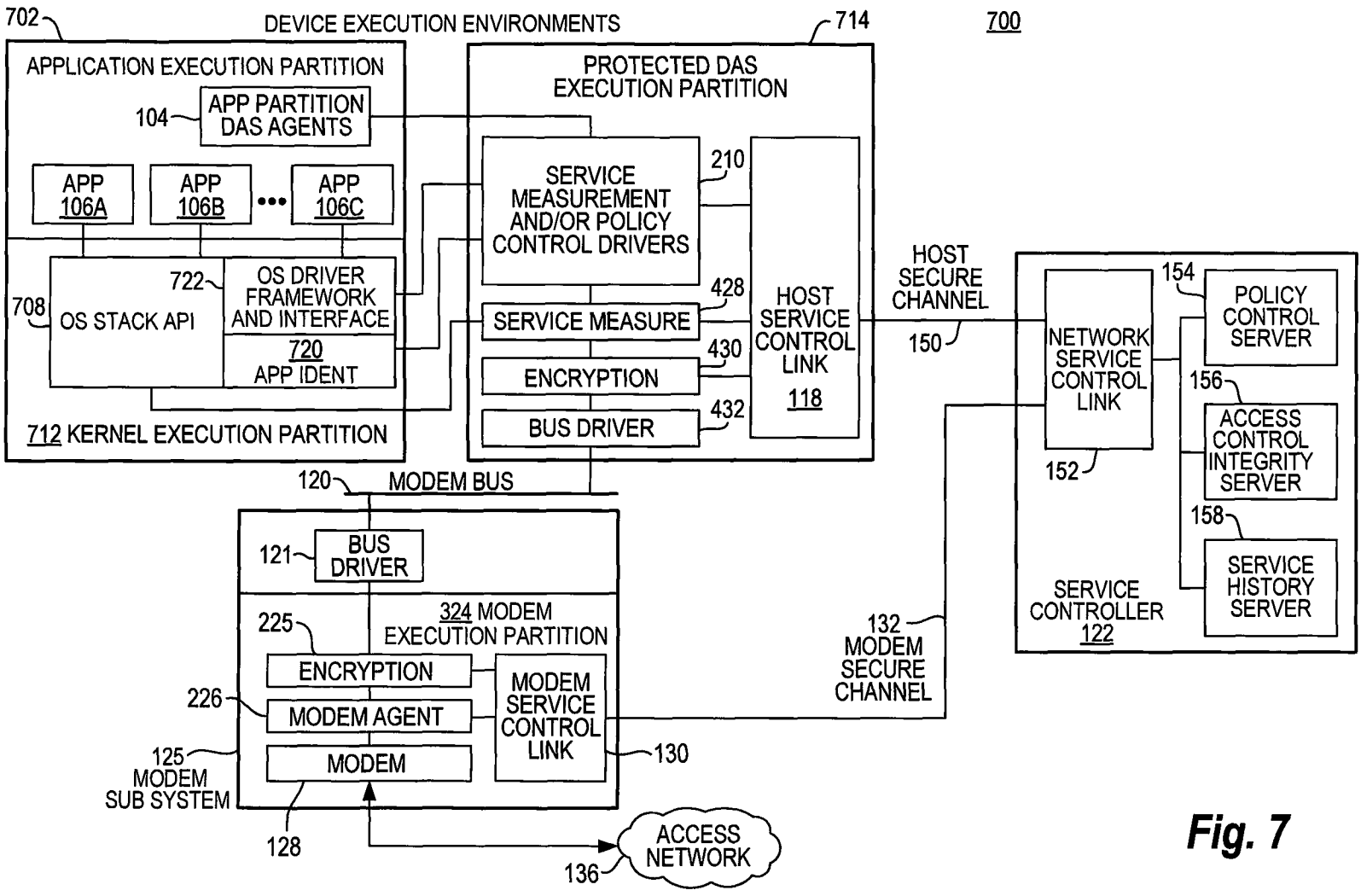

Fig. 7

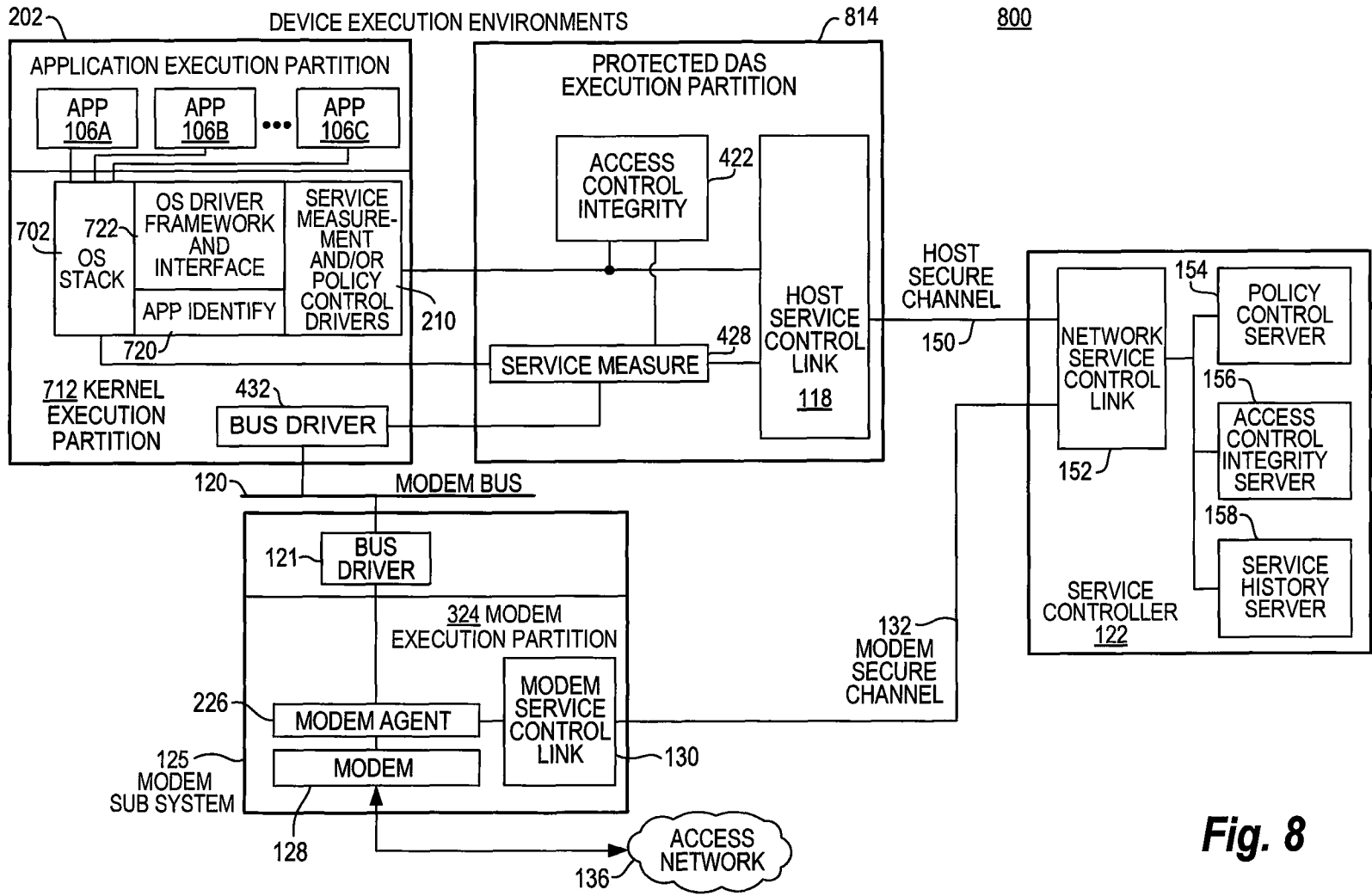

Fig. 8

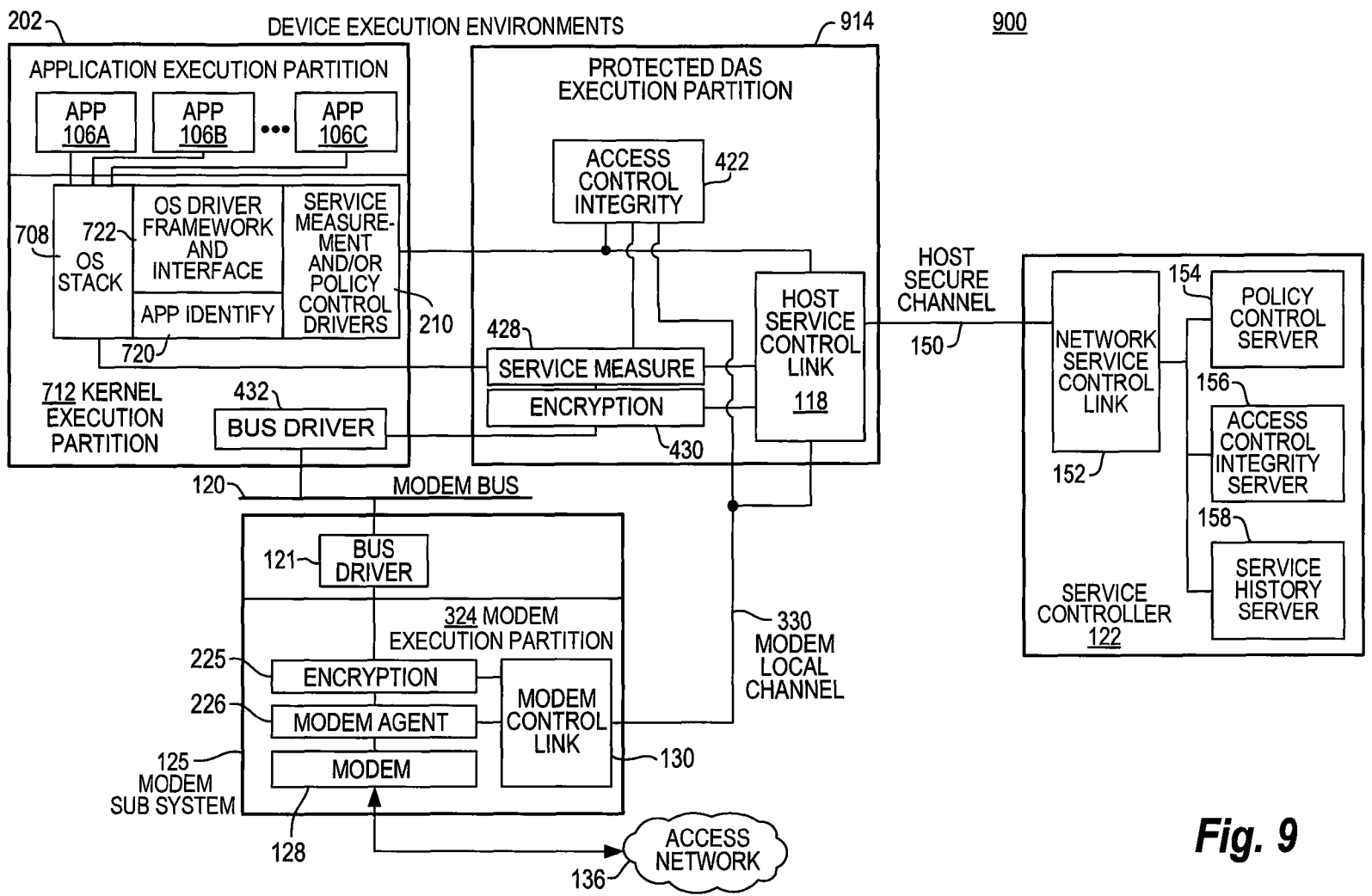

Fig. 9

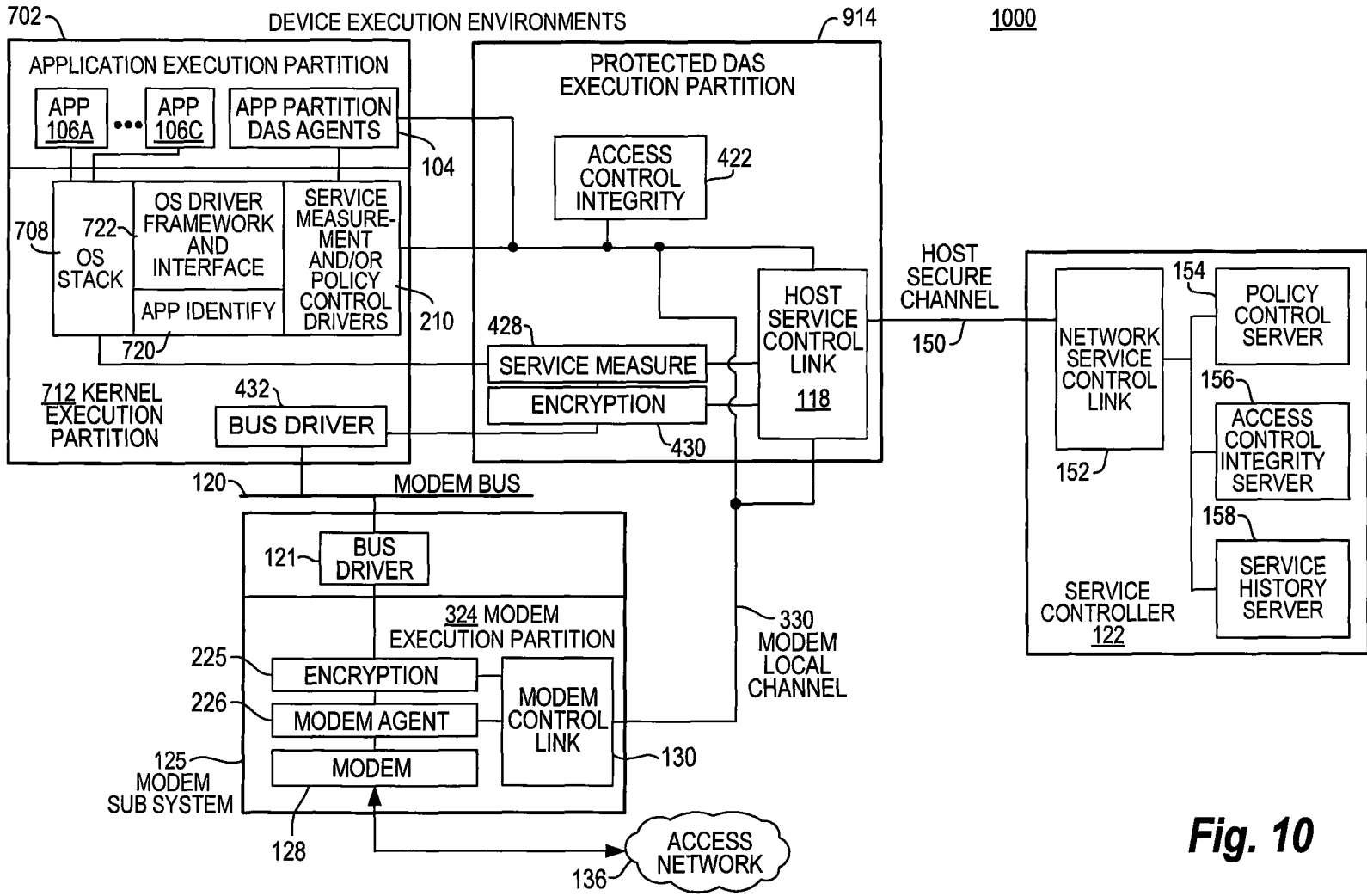

Fig. 10

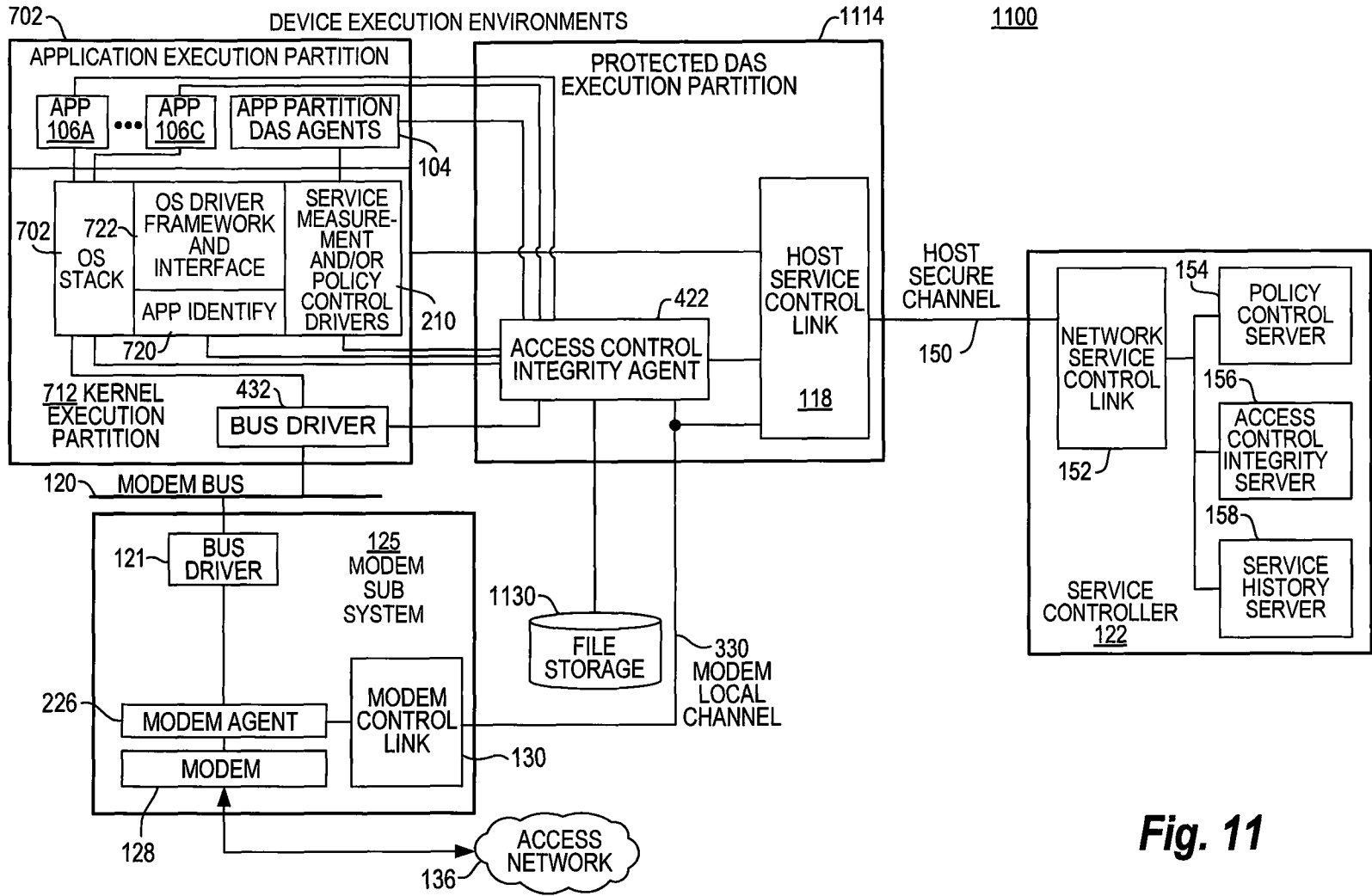

Fig. 11

1

SECURITY TECHNIQUES FOR DEVICE ASSISTED SERVICES

CROSS REFERENCE TO OTHER APPLICATIONS

This application is a continuation of application Ser. No. 12/694,445, filed Jan. 27, 2010, entitled SECURITY TECHNIQUES FOR DEVICE ASSISTED SERVICES, which is a continuation-in-part of application Ser. No. 12/380,780, filed Mar. 2, 2009, entitled AUTOMATED DEVICE PROVISIONING AND ACTIVATION, both of which are incorporated herein by reference for all purposes.

Application Ser. No. 12/694,445, filed Jan. 27, 2010, entitled SECURITY TECHNIQUES FOR DEVICE ASSISTED SERVICES, claims the benefit of provisional Application No. 61/206,354, filed Jan. 28, 2009, entitled SERVICES POLICY COMMUNICATION SYSTEM AND METHOD, provisional Application No. 61/206,944, filed Feb. 4, 2009, entitled SERVICES POLICY COMMUNICATION SYSTEM AND METHOD, provisional Application No. 61/207,393, filed Feb. 10, 2009, entitled SERVICES POLICY COMMUNICATION SYSTEM AND METHOD, provisional Application No. 61/207,739, filed Feb. 13, 2009, entitled SERVICES POLICY COMMUNICATION SYSTEM AND METHOD, and provisional Application No. 61/252,151, filed on Oct. 15, 2009, entitled SECURITY TECHNIQUES FOR DEVICE ASSISTED SERVICES, all of which are incorporated herein by reference for all purposes.

Application Ser. No. 12/380,780, filed Mar. 2, 2009, entitled AUTOMATED DEVICE PROVISIONING AND ACTIVATION, claims the benefit of provisional Application No. 61/206,354, filed Jan. 28, 2009, entitled SERVICES POLICY COMMUNICATION SYSTEM AND METHOD, provisional Application No. 61/206,944, filed Feb. 4, 2009, entitled SERVICES POLICY COMMUNICATION SYSTEM AND METHOD, provisional Application No. 61/207,393, filed Feb. 10, 2009, entitled SERVICES POLICY COMMUNICATION SYSTEM AND METHOD, and provisional Application No. 61/207,739, filed Feb. 13, 2009, entitled SERVICES POLICY COMMUNICATION SYSTEM AND METHOD.

BACKGROUND OF THE INVENTION

With the advent of mass market digital communications, applications and content distribution, many access networks such as wireless networks, cable networks and DSL (Digital Subscriber Line) networks are pressed for user capacity, with, for example, EVDO (Evolution-Data Optimized), HSPA (High Speed Packet Access), LTE (Long Term Evolution), WiMax (Worldwide Interoperability for Microwave Access), DOCSIS, DSL, and Wi-Fi (Wireless Fidelity) becoming user capacity constrained. In the wireless case, although network capacity will increase with new higher capacity wireless radio access technologies, such as MIMO (Multiple-Input Multiple-Output), and with more frequency spectrum and cell splitting being deployed in the future, these capacity gains are likely to be less than what is required to meet growing digital networking demand.

Similarly, although wire line access networks, such as cable and DSL, can have higher average capacity per user compared to wireless, wire line user service consumption habits are trending toward very high bandwidth applications and content that can quickly consume the available capacity and degrade overall network service experience. Because

2

some components of service provider costs go up with increasing bandwidth, this trend will also negatively impact service provider profits.

BRIEF DESCRIPTION OF THE DRAWINGS

Various embodiments of the invention are disclosed in the following detailed description and the accompanying drawings.

FIG. 1 illustrates a secure execution environment for device assisted services in accordance with some embodiments.

FIG. 2 illustrates another secure execution environment for device assisted services in accordance with some embodiments.

FIG. 3 illustrates another secure execution environment for device assisted services in accordance with some embodiments.

FIG. 4 illustrates another secure execution environment for device assisted services in accordance with some embodiments.

FIG. 5 illustrates another secure execution environment for device assisted services in accordance with some embodiments.

FIG. 6 illustrates another secure execution environment for device assisted services in accordance with some embodiments.

FIG. 7 illustrates another secure execution environment for device assisted services in accordance with some embodiments.

FIG. 8 illustrates another secure execution environment for device assisted services in accordance with some embodiments.

FIG. 9 illustrates another secure execution environment for device assisted services in accordance with some embodiments.

FIG. 10 illustrates another secure execution environment for device assisted services in accordance with some embodiments.

FIG. 11 illustrates another secure execution environment for device assisted services in accordance with some embodiments.

DETAILED DESCRIPTION

The invention can be implemented in numerous ways, including as a process; an apparatus; a system; a composition of matter; a computer program product embodied on a computer readable storage medium; and/or a processor, such as a processor configured to execute instructions stored on and/or provided by a memory coupled to the processor. In this specification, these implementations, or any other form that the invention may take, may be referred to as techniques. In general, the order of the steps of disclosed processes may be altered within the scope of the invention. Unless stated otherwise, a component such as a processor or a memory described as being configured to perform a task may be implemented as a general component that is temporarily configured to perform the task at a given time or a specific component that is manufactured to perform the task. As used herein, the term "processor" refers to one or more devices, circuits, and/or processing cores configured to process data, such as computer program instructions.

A detailed description of one or more embodiments of the invention is provided below along with accompanying figures that illustrate the principles of the invention. The invention is described in connection with such embodiments, but the

invention is not limited to any embodiment. The scope of the invention is limited only by the claims and the invention encompasses numerous alternatives, modifications and equivalents. Numerous specific details are set forth in the following description in order to provide a thorough understanding of the invention. These details are provided for the purpose of example and the invention may be practiced according to the claims without some or all of these specific details. For the purpose of clarity, technical material that is known in the technical fields related to the invention has not been described in detail so that the invention is not unnecessarily obscured.

In some embodiments, security techniques for device assisted services are provided. In some embodiments, secure service measurement and/or control execution partition techniques for device assisted services are provided. In some embodiments, a secure execution environment for device assisted services is provided. In some embodiments, a secure stack for device assisted services is provided. In some embodiments, a secure memory for device assisted services is provided. In some embodiments, a secure modem for device assisted services is provided (e.g., providing a secure communication link between the modem/modem driver and a service processor and/or agent on the device, such as a communications device or an intermediate networking device). In some embodiments, one or more secure monitoring points for device assisted services are provided. In some embodiments, one or more secure monitoring points with verification for device assisted services are provided (e.g., a secured monitoring point can be provided in a modem, which communicates securely to a secured execution environment in a CPU/processor, which can then verify such service usage measures). In some embodiments, a secure bus for device assisted services is provided. In some embodiments, a secure execution environment in the CPU/processor for device assisted services is provided. In some embodiments, secure access to a secure execution environment(s) for device assisted services is provided (e.g., securing communication from a bottom of the stack, such as modem drivers, which require credentials to access the bus as controlled by a service processor or secure agent on the device, and in which the traffic on the bus is encrypted). In some embodiments, various secure execution environments for device assisted services are provided using various hardware partition techniques (e.g., secure memory, secure modems, secure memory partition(s) in the CPU/processor), as described herein.

In some embodiments, device assisted services (DAS) provide for one or more of device based service usage measurements, service usage policy implementation, service usage accounting, service usage control, and any of the other functions described in various embodiments that assist, replace, and/or augment network based functions. For example, various DAS embodiments perform one or more of the following: facilitate and control activation to one or more access service networks; measure access and/or service usage on one or more access networks; control access and/or service usage on one or more access networks; account for different types of service usage on one or more access networks; implement quality of service (QOS) controls, collect and report QOS traffic demand, aggregate multiple device QOS demand reports to assess a measure of overall network QOS demand, and/or facilitate QOS resource allocation; and/or facilitate roaming between access networks. There are many more functions and embodiments for DAS as described with respect to various embodiments.

In some embodiments, various program/functional elements that perform the functions to implement various DAS

embodiments are referred to herein as DAS agents or device assisted service agents, or in some embodiments, more specific terms are used to be more descriptive in specific examples. In some embodiments, device assisted service agent functions include service measurements and/or service measure recording and/or service measure reporting (e.g., to the service controller, the device, the user, or other device agents) and/or service measure synchronization (e.g., between device and network). In some embodiments, device assisted service agent functions include service usage controls and/or service usage control policy settings. In some embodiments, service usage controls include one or more of network authorization, network authentication, network admission, access control, service usage activity classification, allowing or disallowing one or more service usage activity and traffic shaping for one or more service usage activity.

In some embodiments, device assisted service agent functions include one or more of the following: reporting service usage to QOS control elements in the network, receiving QOS assignment from the network, reporting QOS assignments to the network, and/or communicating with QOS service reservation elements in the network. In some embodiments, device assisted service agent functions include one or more of implementing QOS service controls on the device based on one or more of the following criteria: fair queuing of service usage activities, differentiated QOS based on an assigned QOS hierarchy of service usage activities, service usage activity QOS assignments from the network for one or more service usage activities, service usage activity policy directives from the network for one or more service usage activities.

In some embodiments, a service control link is used for communication between the device assisted service agents and the service controller. In some embodiments, the service control link is a secure link (e.g., an encrypted communication link).

In some embodiments, the device assisted service agent functions include device assisted service system communication, measuring and/or recording and/or reporting and/or synchronizing service measures, observing communicating information for service control integrity, communicating information for service control policy instructions and/or settings, or updating device assisted software and/or agent settings.

In some embodiments, device assisted service on the device includes the following: service measurements, service controls, user interface and usage reporting, user policy options, accept policy instructions, protected execution partition provided to prevent hacking, malware, errors, and other security techniques. In some embodiments, device assisted service on the server includes one or more of the following: set policy, set configurations, install/update agents, check usage versus policy, check proper operation of agents, synchronize usage from network to device, and other verification techniques. For example, when errors in policy enforcement are detected, servers can perform actions to either further observe, quarantine, or suspend the device.

In some embodiments, a control server/control service network element receives service measures from the device. In some embodiments, the control server/control service network element receives service measures from the network. In some embodiments, the control server/control service network element sets policies and manages service across multiple networks (e.g., while one modem is shown in various figures, multiple modems can be employed for multiple networks with consistent service usage measures, service con-

5

trols, QOS controls, UI (User Interface), user preferences, user usage reporting, and/or other settings/controls across different networks).

In some embodiments, traffic type refers to one or more of the following: best effort network traffic, real-time traffic (e.g., live voice such as VoIP, live video, etc.), streaming traffic, multi-cast traffic, uni-cast traffic, point to point traffic, file types, traffic associated with an application, real time traffic, traffic with an assigned priority, traffic without an assigned priority, and traffic for a certain network.

In some embodiments, service usage activity refers to a usage of service by a device. In some embodiments, service usage activity can be one or more of connection to an access network, connection to certain destinations, URLs or addresses on a network, connection to the network by one or more applications, transmission of certain types of traffic, a type of transaction based service, a type of advertising based services, or a combination of one or more of the following: an application type, a network destination/address/URL, a traffic type, and a transaction type.

In some embodiments, protection of the device assisted service agents/functional elements to protect the functions that perform the device assisted functions is provided with a protected execution partition on the CPU (Central Processor Unit), APU (Auxiliary Processor Unit), or another hardware based processor. For example, such hardware protected execution capabilities in the CPU, APU, or other processor can be combined in some embodiments with either OS software functions or other native mode software functions to create secure program execution partitions as described herein. In some embodiments, the term host is used to refer to the hardware and firmware and/or software system that executes the device applications and networking stack. In some embodiments, some of the device assisted service agents/functions are implemented in a modem execution partition environment.

FIG. 1 illustrates a secure execution environment **100** (e.g., for a communications device) for device assisted services in accordance with some embodiments. As shown in FIG. 1, the device execution environments include program/functional elements for a communications (e.g., a communications device can be an intermediate networking device, such as 3G/4G WWAN to WLAN bridges/routers/gateways, femto cells, DOCSIS modems, DSL modems, remote access/backup routers, and other intermediate network devices, or a mobile communications device, such as a mobile phone, a PDA, an eBook reader, a music device, an entertainment/gaming device, a computer, laptop, a netbook, a tablet, a home networking system, and/or any other mobile communications device) device that utilizes the modem subsystems #1 (**125**) through #N (**127**) to connect to one or more of the access networks #1 (**136**) through #N (**138**). In some embodiments, a communications device includes multiple program execution partitions. As shown in FIG. 1, four execution partitions are provided: an application execution partition **102** in which, for example, application programs execute, a kernel execution partition **112** in which, for example, the lower level drivers and basic low level OS programs execute, a protected device assisted service (DAS) execution partition **114** (also referred to as protected DAS partition) in which, in some embodiments, some or all of the device assisted service agents and/or functions execute, and a modem execution partition **124** in which, for example, the modem program elements execute and, in some embodiments, some or all of the device assisted service agents and/or functions execute. In some embodiments, each of these execution partitions are optimized for different software functions, each providing

6

programs with the basic physical memory, data memory, CPU or APU or modem processor execution resources, high level and/or low level OS, memory management, file storage, I/O device resources (e.g., user interface (UI), peripherals, etc.), network communications stack, other device resources, and/or other resources that are required or used for operation of the programs. The collection of these hardware and software resources for the CPU or APU is sometimes referred to herein with the term host.

As shown, FIG. 1 illustrates an application execution partition **102** and a kernel execution partition **112**, which are shown as separate partitions within the device execution environments. For example, this separation is based on the manner in which “kernel programs” (e.g., drivers and network stack, etc.) are commonly supported as compared to “application programs” (e.g., browsers, word processors, user interfaces, etc.) within the context of several different popular operating systems (OS) (e.g., Windows, UNIX, Linux, MAC OS, certain mobile device OSs, certain embedded device OSs, etc.). In some embodiments, this functional separation is not required, and, in some embodiments, other functional separations are supported.

As shown in FIG. 1, protected device assisted service agents, such as the protected DAS partition device assisted service agents **110**, execute in the protected DAS partition **114** while unprotected device assisted service agents and/or OS networking stack elements and applications (e.g., applications **106A** through **106C**) execute outside of the secure device assisted service execution partition **114**, such as the application partition device assisted service agents **104** and the OS networking stack and/or kernel partition device assisted service agents **108**. For example, the protected DAS partition **114** can make it more difficult for a hacker, malware or system errors to compromise, attack or modify the device assisted service measurements, service policy implementation or service usage control operations on the device (e.g., communications device). In some embodiments, the protected DAS partition **114** need not support open access to all programs and OS elements so that it can be easier to protect. Also, as shown, a bus driver **116** in the application execution partition **102** provides for communication with a modem bus **120**, which is in communication with a bus driver **121** in the modem execution partition **124**. The protected DAS partition also includes a host service control link **118**, which facilitates communication with a host secure channel **150** as shown.

In some embodiments, the protected DAS partition **114** is a protected execution partition on the main device that is supported by certain configurations in the host (e.g., a secure virtual execution environment or a separate hardware security function). For example, this protected execution partition can be used to provide added service measurement integrity and/or service control integrity for a device assisted service enabled device. In some embodiments, as described herein, the operating system (OS) also performs a role in establishing the protected execution partition for secure operation of device assisted services, and, in some embodiments, this role is performed by native software or firmware operating on secure hardware elements.

In some embodiments, the DAS agents responsible for maintaining service control integrity execute in the protected DAS partition **114**. For example, the protected DAS partition device assisted service agents **110** can include one or more of the following: one or more service usage measurement functions; some or all of the device networking stack functions that are monitored and/or controlled by the device assisted services system; device drivers that interface to an OS networking stack to observe or manipulate stack traffic; access

control integrity functions; service policy control functions; service UI functions; application identification functions, and/or functions to classify service usage activities by combinations of application, address/URL and/or traffic type; modem bus driver functions; and/or modem data encryption functions to prevent other unauthorized programs from bypassing the device assisted service measurements and/or controls by directly accessing the modem around the stack. In some embodiments, the system designer or a given set of design criteria determine which of the various described device assisted agent functions should be executed in protected DAS partition **114** to strengthen the service control integrity for the system.

In some embodiments, the device operating system provides for the protected DAS partition **114** in addition to conventional security features available in the operating system. In some embodiments, the protected DAS partition **114** provides an execution partition with increased program execution protection in which, for example, service measurement and/or service control programs (agents) can execute in a mode that provides for higher access control integrity (e.g., proper service usage reporting and/or service measurement and/or service control system operation with increased protection from attacks, errors, malware, etc.). In some embodiments, a hardware assisted secure execution partition provides for increased program execution protection for device assisted service agent functions.

In some embodiments, a service control link (e.g., host service control link **118** via host secure channel **150** to network service control link **152**) is used for communication between the device assisted service agents and a service controller **122**. In some embodiments, the service control link is a secure link (e.g., an encrypted communications link). In some embodiments, an encrypted secure control link can be implemented over the higher layers of the network stack (e.g., TCP, HTTP, TLS, etc.), and, in some embodiments, the encrypted link can be implemented over lower layers in the network stack, such as the IP layer or the access network layers (e.g., the WWAN device management channels or signaling layers). In some embodiments, service control link security is provided at least in part by encrypting link traffic between the device and the service controller **122**. In some embodiments, service control link security is provided at least in part by running the service control link device side program agents in the protected DAS partition **114**. In some embodiments, service control link security is achieved at least in part by restricting access to the service control link to certain device assisted service agents that are allowed to communicate with the service controller **122**. In some embodiments, the agents that are allowed to communicate with the service control link perform such communications using encrypted communications. In some embodiments, the encrypted communications is accomplished with a secure inter-agent communication bus on the device. In some embodiments, the only mechanism for modifying the configuration of the operation, execution code, execution instructions and/or settings of certain device assisted service processor agents executing in the protected DAS partition **114** is through the service control link. In some embodiments, the only mechanism for modifying any program elements executing inside the protected DAS partition **114** is through the service control link so that only the service controller **122** may modify the operation or service policy settings for the agents located in the service measurement and/or service control execution partition.

As shown in FIG. 1, various server functions within the service controller **122** are provided. In some embodiments, a service history server **158** collects service usage measures

from one or more of the device DAS agents and/or from various sources of potential network based service usage databases, such as the access network service usage **142** (e.g., carrier charging data record (CDR) systems), private network service usage **144** (e.g., MVNO or enterprise network service usage accounting system), and/or billing, mediation service usage log, reconciliation **148** (e.g., service provider billing or mediation system). In some embodiments, an access control integrity server **156** is used to compare various access control verification checks to ensure that the device assisted service agents have not been compromised. The various embodiments used in the access control integrity server **156** to perform these integrity checks are described with respect to various embodiments. Some embodiments include comparing device based service usage measures versus the service usage that should result if the desired service policy were properly implemented, comparing device based service usage measures versus the service usage that should result if the desired service policy were properly implemented with device based service usage measures that are executing in the protected DAS partition **114** and/or the modem execution partition **124**, comparing network based service usage measures versus the service usage that should result if the desired service policy were properly implemented, and comparing network based service usage measures with device based service usage measures. In some embodiments, a policy control server **154** stores policy settings for the various service plans that can be implemented on the device, and communicates the appropriate policy settings to the appropriate device DAS agents.

In some embodiments, the service controller **122** has secure access to service measures, service control settings, software images, software security state(s), and/or other settings/functions, for example, by virtue of the hardware enhanced execution partition and the secure channel into the protected DAS partition **114**. For example, the host secure channel **150** can be encrypted employing keys that are public/private or point to point private. Also, other link security, for example, can be implemented as described herein. For example, servers can ensure that the link remains authenticated and information is validated. For example, the service controller can perform one or more of the following verification techniques: compare the monitored service usage versus the policy, compare the monitored service usage versus other service usage measures and/or combined with various other network service usage measures.

In some embodiments, the protected DAS partition **114** includes a host service control link **118** as shown in FIG. 1 that works in combination, that is, in communication with a network service control link **152** to send and receive secure messages between the service controller and the host via a host secure channel **150**. In some embodiments, the protected DAS partition **114** only accepts new program images from the service controller **122** and not from local programs or disks. In some embodiments, the protected DAS partition **114** cannot communicate with other applications and/or kernel programs. In some embodiments, the protected DAS partition **114** can also communicate with other applications and/or kernel programs but only to gather information or to set settings. In some embodiments, the protected DAS partition **114** can also communicate with other applications and/or kernel programs but only through a restricted encrypted communication bus that restricts outside program access to protected programs or agent functions, and can also restrict the agents inside of the protected partition from accepting unauthorized information or code modifications from programs outside the protected partition. Various other security tech-

niques can be provided for the DAS execution environments as will be apparent to one of ordinary skill in the art in view of the embodiments described herein.

In some embodiments, the protected DAS partition **114** is created by employing CPU or APU hardware security features in addition to or in alternative to other software security features (e.g., virtual execution partitions) that can be provided by the operating system and/or other software. In some embodiments, the host hardware security features are provided with the operating system secure kernel operating modes. In some embodiments, the host hardware security features used for secure device assisted service execution partition operation are independent of the operating system kernel (e.g., implemented in secure program partitions in a separate secure program area not directly controlled by the OS and/or software that does not have access to the partitions).

In some embodiments, the hardware security features that support the protected DAS partition **114** include preventing other elements on the device from writing and/or reading certain memory areas reserved for device assisted service agents and/or control link functions. In some embodiments, this memory protection function is accomplished by locating the memory in a secure hardware partition that cannot be accessed by unauthorized device program elements (e.g., a separate bank of isolated memory space within the host CPU). In some embodiments, this memory protection function includes encrypting traffic to and from memory so that only authorized device program elements possess the counterpart encryption capability to access the memory. In some embodiments, the mechanism to access device assisted service agent memory and/or certain data elements is restricted to authorized device assisted service agents and/or the service controller via the service control link so that unauthorized program elements on the device cannot alter the device assisted service agent code and/or operation.

In some embodiments, the hardware security features that support the protected DAS partition **114** includes preventing unauthorized elements on the device from accessing the protected storage and/or file storage (e.g., "protected storage," such as disk storage, non-volatile memory, embedded non-volatile memory, such as NVRAM, flash or NVROM, securely embedded non-volatile memory, and/or other types of storage) that is used to store the device assisted service agent programs. In some embodiments, this protected storage is maintained within the secure hardware partitions that also execute one or more of the device assisted service agents so that only authorized device assisted service agents have access to the storage locations. In some embodiments, the images that are stored in such protected file storage must be properly encrypted and signed for a boot loader to authorize loading the device assisted service agent programs into execution memory, and in some embodiments, if the images are not properly signed then an access control integrity error is generated and/or the program is not loaded. In some embodiments, such properly signed DAS images can only be obtained from the service controller. In some embodiments, such DAS images can only be loaded into protected file storage by the service controller. In some embodiments, the hardware security features that prevent unauthorized elements on the device from accessing the protected file storage include encrypting all traffic to and from the secure storage so that only authorized device program elements possess the counterpart encryption capability to access the storage. In some embodiments, access or access rights to re-program a device assisted service agent program store is restricted to the service controller via the service control link so that unautho-

riized program elements on the device are not authorized to alter the device assisted service agent code and/or operation.

In some embodiments, the hardware security features that protect device assisted service agent storage include a protected DAS partition in which an access control integrity agent function is isolated from other device program elements, and a secure service control link is also isolated in a similar manner, and the access control integrity agent scans the execution memory, data memory and/or file storage used by one or more device assisted services agents to measure and/or control services. In some embodiments, the purpose of the scan is to detect changes to the device assisted service agent code and/or data. In some embodiments, the purpose of the scan is to detect other unauthorized program elements or data that may be present in reserved or protected areas used for device assisted service agent execution. In some embodiments, reports of such scan audits are reported over the service control link to the service controller for further processing by use of cloud based resources to identify access control integrity violations. In some embodiments, the access control integrity agent functions include one or more of hashing other device assisted security agents, querying other device assisted security agents, observing the operation of other device assisted security agents or monitoring service measures and then either evaluating the results locally on the device to determine if they are within pre-defined allowable parameters or sending at least some of the results to the service controller for further analysis via the service control link. In some embodiments, the scan audits are compared with earlier versions of the scans to compare code configuration or operational characteristics. In some embodiments, the scan audits are compared against known databases for the code or operational characteristics that should be present in the DAS agents.

In some embodiments, an access control integrity agent, or a new version of the access control integrity agent can be downloaded by the service controller over the secure service control link. For example, this technique provides for a real time assessment of device service control security state as described above in the event that corruption or compromise of the secure device assisted service agent(s) has occurred. In some embodiments, the access control integrity agent that is downloaded can have a different configuration and/or operation than any agent previously loaded onto the device so that it is difficult or impossible for a hacker or malware to spoof the operation of the agent in a short period of time. For example, by requiring the agent to report security assessments back to the server in a period of time that is typically less than what is required to spoof the agent, the agent will either report back an accurate assessment of device status or will be blocked by a hacker or malware, and both of these conditions can provide the information required to take action if the device assisted services system has been corrupted or compromised.

In some embodiments, the protected DAS partition and/or the modem execution partition can be used to securely store some or all of the device credentials that are used for one or more of device group association, activation, authorization to the access network and/or the DAS network, service level, and service usage accounting and/or billing.

In some embodiments, the modem subsystem also includes DAS elements that strengthen the access control integrity of the DAS system. As shown in FIG. 1, one or more modems can include, in some embodiments, DAS agent functions labeled modem partition DAS agents **126**. The modem execution partition **124** of the modem sub system **#1 (125)** of the modem execution partition **124** includes modem partition

11

DAS agents **126** in communication (e.g., secure communication, such as using encrypted communications) with a modem **128** and a modem service control link **130**, which is in communication with the network service control link **152** via the modem secure channel #1 (**132**), as shown. Also, the modem **128** is in communication (e.g., secure communication, such as using encrypted communications) with the access network #1 (**136**), which is in communication with the access network service usage **142** and the Internet **140**, which is in communication with a private network **146**, which is in communication with the private network service usage **144**, as shown.

Example embodiments for DAS agent functions that execute in the modem execution partition include modem encryption and modem service usage measures. In other embodiments, the modem execution partition can also include higher level DAS agent functions, such as stack traffic classification, stack manipulation, access control, and/or traffic control. For example, the modem execution partition can also include a full service processor that is fully capable of managing all aspects of service usage measurement and/or service control. It will now be apparent to one of ordinary skill in the art that the modem execution partition can employ a number of the service security embodiments described in the context of the protected DAS partition, for example, to enhance the service integrity of the DAS system. For example, the DAS agents on the modem can be stored in an encrypted and signed format on non-volatile (NV) memory on the modem that is only accessible by the network service control link or by a local secure control link from the protected DAS partition to the modem execution partition. As shown in FIG. 1, a separate secure modem control channel (e.g., modem secure channel #1 (**132**)) through modem secure channel #N (**134**) that is distinct from the host secure control channel **150** is provided. This separate modem control channel can either be implemented over the higher network layers of the device or over the lower access network layer so that special access to access network resources is required to even connect to the modem DAS agents **126** thereby further enhancing service control related security.

In some embodiments, the protected DAS partition provides for performing the DAS agent functions required for parental controls, enterprise WWAN management controls or roaming controls, and/or usage reporting in the protected execution space. In view of the DAS embodiments described herein, it will now be apparent to one of ordinary skill in the art how to implement such protected controls for these various and other application scenarios.

In some embodiments, a protected DAS partition provides for performing a virtual machine (VM) on top of a secure machine. The device application OS that is accessible by software that can be installed without special permissions can be isolated from the secure hardware and/or OS that is running under the VM. Using these techniques, malware can be “cocooned in” on the VM OS rather than “walled out” as discussed with respect to various embodiments described herein.

In some embodiments, communication between program/functional elements outside of the protected DAS partition to DAS agents inside the protected DAS partition is controlled by a secure encrypted channel. In some embodiments, only programs/functions that have access to communicate with DAS agents are allowed to do so, and, in some embodiments, even these outside programs are not allowed to modify the DAS agent configuration, only to report information and/or receive information.

For example, various embodiments can be used to connect to multiple access networks through multiple modems, with

12

each modem potentially being associated with a different set of DAS service policies corresponding to the different types of access networks supported. In some embodiments, such as for 3G/4G modems, WWAN/WLAN modems, and various other multiple modem embodiments, the multiple modems can also be provided on the same multi-mode modem subsystem rather than on different modem subsystems.

In some embodiments, the various techniques and embodiments described herein can be readily applied to intermediate networking devices as will now be apparent to one of ordinary skill in the art. For example, an intermediate networking device can include some or all of the DAS agents for managing, controlling, and/or measuring service usage for one or more devices in communication with a wireless network via the intermediate networking device, in which the DAS agents can be executed in secure execution environments or secure execution partitions using the various techniques described herein. In some embodiments, intermediate networking devices include, for example, WWAN/WLAN bridges, routers and gateways, cell phones with WWAN/WLAN or WWAN/Bluetooth, WWAN/LAN or WWAN/WPAN capabilities, femto cells, back up cards for wired access routers, and other forms/types of intermediate networking devices.

FIG. 2 illustrates another secure execution environment **200** for device assisted services in accordance with some embodiments. In particular, FIG. 2 illustrates an embodiment in which DAS agents do not actually replace the OS network stack elements, but instead one or more DAS agents include device driver programs that interface into the network stack and pass (e.g., securely communicate) traffic information or actual traffic back and forth with the stack. These device driver interface constructs are labeled OS driver framework and interface **208** as shown in FIG. 2. Example OS system constructs that provide for this type of architecture for DAS agents include Windows NDIS and/or TDI drivers, Windows Filter Platform (WFP), Berkeley Packet Filter, ipfw (e.g., a BSD packet filter that can be used for various OSs, such as Unix, Linux, MAC OS), and/or other platforms/programs performing these or similar functions. While these OS stack options are not secure in themselves, if the drivers that interface with them are secured as illustrated in FIG. 2 by executing the drivers in the protected DAS partition **214**, then higher overall access control integrity/security levels can be achieved.

As shown in FIG. 2, the service measurement and/or policy control drivers **210** executed in the protected DAS partition **214** represent the DAS drivers that interface to the OS stack device driver interface constructs labeled OS driver framework and interface **208** executed in the kernel execution partition **212**, which are in communication with/interface with OS Stack API(s) **207**. As also shown, applications, such as applications **106A** through **106C** execute in the application execution partition **202**. In some embodiments, service access control integrity is further enhanced by placing additional measurement points outside of the network stack, so that, for example, if the network stack service usage reporting is hacked, corrupted, and/or compromised, there is a secure additional or back-up service measure located on the device and/or in the network (e.g., modem agent **226** as shown in FIG. 2, which provides a service measurement point in the modem for measuring service usage by the device, and as shown also provides for secure communication with the modem agent **226** using modem encryption **225**). For example, the service measure provided by the modem agent **226**, modem encryption **225**, and/or modem bus **120** functions shown in FIG. 2 can be executed in a protected partition (e.g., modem execution partition **124** as shown in FIG. 2 can

13

be implemented as a secure or protected partition using the various techniques described herein).

FIG. 3 illustrates another secure execution environment 300 for device assisted services in accordance with some embodiments. As shown, some stack elements are executed in the kernel execution partition 312 and some stack elements are executed in the protected DAS execution partition 314. In some embodiments, the DAS agents 104 executed in the application execution partition 302 are directly monitoring and/or controlling stack traffic by intercepting it and imposing additional traffic measurement and/or filtering. Examples of such techniques are described herein with respect to various embodiments. As shown in FIG. 3, the network stack elements 308 are the OS stack elements that reside in the kernel execution partition 312 and the protected DAS network stack elements 310 are the stack elements that reside in protected DAS execution partition 314. For example, as some or potentially all of the stack network traffic processing resides in the protected DAS execution partition 314, a high level of service control integrity can be maintained using these techniques. For example, the modem bus driver 121 can be executed in a secure execution partition, such as modem execution partition 324, which can be implemented as a secure execution partition using the various techniques described herein, or the modem bus driver 121 can be executed in the protected DAS execution partition 314, so that unauthorized programs can be blocked from accessing the access network through the modem.

In some embodiments, the entire stack is executed in the protected DAS execution partition 314 with only a stack API executing in kernel execution partition 312. Various other embodiments involve implementing a minimum (e.g., in terms of a number of agents and/or functionality) in the protected DAS execution partition 314 required to secure a service measure that can be used to confirm the integrity of the service policy implementation (e.g., as described with respect to various other embodiments disclosed herein). As will now be apparent to one of ordinary skill in the art, various combinations of stack processing functions can be implemented in a secure host execution partition to strengthen the service measurement and/or service control integrity of the DAS system using the techniques and/or similar techniques to the various techniques described herein.

In some embodiments, the stack elements implemented in the protected DAS execution partition can include stack API, sockets layer, TCP, UDP, service measurements at one or more points in the stack, IP layer processing, VPN/IPSEC, PPP, access control, traffic classification, traffic queuing, traffic routing, traffic QOS, traffic demand reporting to QOS allocation servers, traffic statistics reporting to the QOS servers, traffic QOS reservation requests including by traffic type or app type or service priority to the servers, traffic throttling, traffic statistics gathering, traffic QOS priority identification, modem drivers, modem data encryption, and/or other stack element functionality or features.

In some embodiments, the above discussed service control mechanisms are controlled by policy commands received over the service control link from the servers or other authorized network elements. In some embodiments, the device also reports usage measures to servers or other authorized network elements. In some embodiments, the device also reports QOS demand to the servers or other authorized network elements and/or accepts QOS instructions from the servers or other authorized network elements. In some embodiments, the device reports traffic statistics, projected traffic demand, application usage, projected QOS demand can all be reported to the servers or other authorized network

14

elements for the purpose of provisioning the right amount of data bandwidth and traffic priority to the device, and the servers or other authorized network elements aggregate such reports from many different devices to project needed allocations across the entire network and make global bearer channel level or base station level decisions bearer channel allocation and bearer channel QOS allocation decisions, which can also be tied into a bearer channel provisioning, or bearer channel QOS provisioning apparatus or other authorized network elements located in the access network.

For example, as will now be apparent to one of ordinary skill in the art in view of the various embodiments described herein, additional security measures, can be added in some embodiments to augment the secure service partitioning, including, for example, access control integrity checks. For example, in addition to the service control policy instructions that can be received from the servers or other authorized network elements, an intermediate policy control agent can be present to make additional higher level decisions on how instantaneous policy should be implemented.

As shown in FIG. 3, the modem control link, shown as modem local channel 330, provides a link from local connection to the host service control link 118, which in turn connects through the host secure channel 150 to the service controller 152. This communication channel can also be implemented or configured to provide for encrypted communication and, in some embodiments, can be used as an alternative to the direct connection from the modem service control link to the network service control link as disclosed with respect to other figures and various embodiments as described herein.

As shown in FIG. 3, the final stack elements that feed or communicate with the modem bus driver 121 are the protected DAS network stack elements 310 located in the protected DAS execution partition 314 (illustrated as a solid line in FIG. 3), or, in some embodiments, can be the network stack elements 308 located in the kernel execution partition 312 (illustrated as a dashed line in FIG. 3). In some embodiments, these final stack elements feed or communicate with the modem subsystem 125. In some embodiments, the modem subsystem 125 includes an encrypted link so that the stack elements 310 in the protected DAS execution partition 314 can communicate with the modem 128 but other software programs or hardware elements cannot, for example, thereby preventing the service measures and/or controls from being inappropriately bypassed or otherwise comprised. For example and as similarly discussed above, the modem subsystem 125, for example, can include its own the protected execution partition using various techniques described herein. The modem protected execution partition, for example, can also include a service measure (e.g., modem agent 226 can provide such a service measurement point in the modem subsystem 125, as similarly described above with respect to FIG. 2) to increase service control integrity verification as depicted by service measure. The modem service measure can be included in protected execution partition that can only be accessed by the service controller 122 by way of the modem local channel 330, or the modem service measure can only be accessed by another DAS agent 310 in protected execution partition 314. In some embodiments, the modem local channel 330 is implemented as a secure channel (e.g., an encrypted communication channel between the modem service control link 130 and the host service control link 118). As described herein, the modem driver can reside in protected service execution environment, or the modem traffic can be

15

encrypted within service execution environment. For example, the encryption settings can be controlled by various secure control servers.

FIG. 4 illustrates another secure execution environment **400** for device assisted services in accordance with some embodiments. In particular, FIG. 4 illustrates a direct stack manipulation option performed by the DAS agents executed in the protected DAS execution partition **414**, including, as shown, an app(lication) identify agent **420**, an access control integrity agent **422**, a policy control agent **424**, a policy implementation agent **426**, a service measure/service monitoring agent **428**, a modem encryption agent **430**, and a bus driver **432**. For example, the policy implementation agent **426** performs access control and/or traffic shaping according a set of service control policies. The service control policies, for example, can be set by the service controller **122** or by the service controller **122** in coordination with the policy control agent **422**. As shown the app identify agent **420** is in communication with the various applications **106A** through **106C** executed in the application execution partition **402**. As also shown, the various applications **106A** through **106C** executed in the application execution partition **402** are in communication with the OS stack and/or stack API(s) **408** executed in the kernel execution partition **412**.

In some embodiments, the protected service measure agent **428**, the modem encryption agent **430**, the modem driver agent **432**, the application identifier agent **420**, the access control integrity agent **422**, and the policy control agent **424** are all implemented in protected DAS partition **414**, as shown. In some embodiments, as will now be apparent to one of ordinary skill in the art, a subset of these functions can be implemented in a protected execution partition, such as the protected DAS partition, in various circumstances.

FIG. 4 also similarly shows various embodiments that are available for network based service usage measures and interfacing to the mediation and billing systems, and it should be understood that any or all of the embodiments and figures can be employed in the context of carrier networks, MVNOs, private networks, or open networks supporting enterprise IT manger controls, parental controls, multi-network controls, and/or roaming controls.

FIG. 5 illustrates another secure execution environment **500** for device assisted services in accordance with some embodiments. In particular, FIG. 5 is similar to that FIG. 4 except that FIG. 5 illustrates a modem service control link **132** that is connected directly to the service controller **122** via the network service control link **152** (e.g., via a modem secure channel). In some embodiments, a modem control link for DAS is established locally on the device or through an entirely different control channel, which, in some embodiments, provides enhanced security as discussed herein (e.g., it is very difficult to hack a service usage measure or service control that cannot be accessed on the device).

FIG. 6 illustrates another secure execution environment **600** for device assisted services in accordance with some embodiments. In particular, FIG. 6 illustrates a policy implementation agent **616** that includes the entire networking stack running in protected execution partition **614** and an OS stack API **608** that includes an application identifying function **620** in the kernel execution partition **612**.

FIG. 7 illustrates another secure execution environment **700** for device assisted services in accordance with some embodiments. In particular, FIG. 7 illustrates DAS agents that do not replace the OS network stack elements, but instead one or more DAS agents are comprised of device driver programs that interface into the network stack and pass traffic information or actual traffic back and forth with the stack. These

16

device driver interface constructs are labeled OS driver framework and interface **722** in FIG. 7 as similarly shown in and described with respect to FIG. 2, along with OS stack API **708**, which includes application identifier function **720** as similarly discussed above with respect to FIG. 6, and are executed in kernel execution partition **712**. Also, as shown, application partition DAS agents **104** are executed in application execution partition **702**. The main difference between the embodiment in FIG. 7 and that shown in and described with respect to FIG. 2 is that the service measure agent **428**, modem encryption agent **430**, and modem driver agent **432** are executed in the protected DAS partition **714**, as shown in FIG. 7. For example, this provides for enhanced service control security as described herein with respect to various embodiments.

FIG. 8 illustrates another secure execution environment **800** for device assisted services in accordance with some embodiments. In particular, FIG. 8 illustrates a more simplified embodiment that is similar to that of FIG. 7. In FIG. 8, only an access control integrity agent **422** and a service measure **428** are executed in protected DAS partition **814**, and the bus driver **432** and the service measurement and/or policy control drivers **210** are executed in the kernel execution partition **712**. This embodiment illustrates that provided that at least one protected service measure is provided on the device, then the DAS service control integrity can be very high. For example, if it is not possible to access the program code or control traffic for the service measure agent **428**, and the host service control link **118** except through the encrypted control channel from the service controller **122**, then this simplified configuration can be almost as secure as that possible with network based service measures. It will now be apparent to one of ordinary skill in the art that this technique similarly applies to a service measure and control link similarly implemented in a protected modem execution partition **324**. In some embodiments, the access control integrity agent **422** provides additional security, for example, in the event that the protected DAS partition **814** is breached or compromised.

FIG. 9 illustrates another secure execution environment **900** for device assisted services in accordance with some embodiments. In particular, FIG. 9 illustrates an embodiment similar to that of FIG. 8 except that, in particular, in addition to the service measure being executed in protected DAS partition **914**, the modem encryption agent **430** is also implemented in/executed in the protected DAS partition **914**. For example, this prevents unauthorized software from defeating the service measurements and/or service controls by going around the network stack directly to the modem.

FIG. 10 illustrates another secure execution environment **1000** for device assisted services in accordance with some embodiments. In particular, FIG. 10 illustrates an embodiment similar to that of FIG. 9 except that, in particular, there are additional app partition DAS agents **104** executing in the application execution partition **702**. For example, this illustrates that some DAS agents can be implemented in application space (e.g., UI agent, policy control agent, and various other DAS agents as described herein) while still maintaining a high level of service measurement and/or control security as long as there are a few key measures and/or controls implemented in protected execution partitions using the various techniques described herein.

FIG. 11 illustrates another secure execution environment **1100** for device assisted services in accordance with some embodiments. In particular, FIG. 11 illustrates how the server cloud can be assisted by the on board access control integrity agent to detect tampering with other service measurement(s) and/or control agent(s), or to protect the service measurement

17

and/or control system from being attacked by malware and/or otherwise comprised. As shown, the access control integrity agent 422 executes inside the protected DAS partition 1114 and is in communication with file storage 1130 (e.g., for persistently maintaining device status and/or other settings or status or monitoring information). The access control integrity agent 422 performs the various access control integrity check functions as, for example, described herein with respect to various embodiments, and, in some embodiments, in coordination with the servers over the secure control channel (e.g., host secure channel 150). In some embodiments, the access control integrity agent 422 can send the service controller 122 information about the other service measurements and/or control agents so that the service controller 122 can determine if the agents are working properly or have been tampered with or otherwise compromised. For example, such information can include sections of code, hashes, code segments, code variations from a previous image, code variations from a historical image, responses to queries, checksums, observations of operating behavior or patterns, service usage, policy implementation behavior, and/or other information that may be indicative of tampering, corruption, and/or a compromise of any of the device agents/measures. In some embodiments, the access control integrity agent 422 checks the operating environment for signs of malware signatures, or sends application and/or driver information or other information about the operating environments to the servers for further processing to detect malware. In some embodiments, the access control integrity agent 422 performs basic operations on protected DAS partition memory, kernel execution partition memory areas, application execution partition memory areas, on disk storage areas or on other file storage areas to detect known malware hashes or signatures, etc., or the access control integrity agent 422 can send the hashes to the servers for comparison against malware databases (e.g., to compare against signatures for known malware or for further behavior based or other security/malware detection techniques).

In some embodiments, the DAS system is implemented in a manner that is robust to losses in service control link (e.g., coverage outages on a WWAN link or loss of connection on a wired link). In some embodiments, the DAS system to be implemented in a manner that is robust to one or more server elements in the service controller going offline or failing for any reason. The following embodiments facilitate these techniques, as described below.

In some embodiments, it is advantageous for one or more of the device assisted service agents to maintain a record of the service usage reports and/or other reporting that is provided to the service controller regarding device service control state (e.g., present service plan settings, current service usage policy settings, current user preference settings, current DAS settings, current encrypted control channel and/or local encrypted communication channel key information, current DAS agent status reports, current DAS agent security state reports, current ambient service usage and/or transaction records, current service control integrity threat reports, user status information, device status information, application status information, device location, device QOS state, and/or other state and/or settings information). In addition to such information that exists on the device and is reported to the service controller, additional service information can be derived and recorded in the service controller, such as information received from outside the device and/or analysis of the device reported information (e.g., network based service usage measures, analysis of device service usage, comparison of device reports with other information, analysis of access control integrity agent reports, information received from

18

roaming networks, information input to the service controller from parental control terminals, enterprise control terminals, virtual service provider control terminals, access network authorization information, service integrity violation level, and many other types of information used to properly measure and/or control the device services). For example, the information reported from the device and received or derived outside the device that is required to adequately define the actions needed from the service controller to maintain proper DAS system operation is sometimes referred to herein as the "device service state."

In some embodiments, the service controller functions are highly scalable and can be executed on a number of hardware and software platforms (e.g., different virtual machines in a server, different servers in a data center, or different servers located in different data centers). For example, in such embodiments the service controller can be designed so that the programs that execute the various service controller server functions can derive all of the information necessary to properly manage the device at any moment in time by knowing past device service state and current service state that adequately define the next set of actions the service controller needs to implement to properly maintain the DAS system operation. By designing the system in this way, if the server that is running the service controller server functions for any given device in question were to go down or become disconnected from the device, then another server could later resume proper operation of the DAS system by assigning another service controller server function to the device and recovering or restoring the necessary past device service state and the necessary current device service state.

For example, this can be accomplished in some embodiments as described below. The service controller saves the current device service state into a common database (e.g., which can be centralized or distributed) that is available to all service controller server functions. The device service state is saved each time the device communicates with the service controller, or at regular time intervals, or a combination of both. The device retains its current and past service state reports even after they are reported at least until the service controller sends the device a message confirming that the service controller has saved a given device service state. Once the device receives this save confirmation for a given device state report then it is no longer required to retain that particular device state report once the device has no further use for it. In this manner, if a service controller server function goes down then a save confirmation for one or more reported device states is not transmitted to the device by the service controller, and the device can retain that report. A server load balancer detects that a given service controller server function has gone down, looks up the devices that were being controlled by that service controller server function, finds that the device in question was one of those devices and re-assigns a new service controller server function (either in the same data center or in another data center) to control the device in question. The newly assigned service controller server function then recovers all past device states that were recorded in the service controller database and are required to properly manage the DAS system, and then asks the device to transmit or re-transmit all device state reports that were not saved in the service controller database. Once the device transmits or re-transmits the requested information, the newly assigned service controller function then has the information it needs to properly manage the DAS system, it saves all the reported device state information, and then sends save confirmations to the device so that the device need no longer retain the older service state reports. The newly assigned service controller

19

server function can then resume the DAS system operation with a set of actions that are identical or very similar to the actions that would have been taken by the original service controller server function if it had not gone down. One of ordinary skill in the art will now appreciate that the above techniques can also be used to accommodate temporary losses in the connection between the device and the service controller. For example, such techniques provide for a highly scalable and robust approach to implement a distributed service controller across multiple data centers for reliable service redundancy. In some embodiments, the past device service state information is saved in the protected DAS execution partition and/or the modem execution partition, for example, so that it is protected from corruption.

Although the foregoing embodiments have been described in some detail for purposes of clarity of understanding, the invention is not limited to the details provided. There are many alternative ways of implementing the invention. The disclosed embodiments are illustrative and not restrictive.

What is claimed is:

1. A method comprising:
 - receiving, over a service control link, a report from a wireless end-user device, the report comprising information about a device service state;
 - determining, based on the report, that a particular service policy setting of the wireless end-user device needs to be modified, the particular service policy setting being stored in a protected partition of the wireless end-user device, the protected partition configured to deter or prevent unauthorized modifications to the particular service policy setting, the particular service policy setting being associated with a service profile that provides for access by the wireless end-user device to a network data service over a wireless access network, the particular service policy setting configured to assist in controlling one or more communications associated with the wireless end-user device over the wireless access network; and
 - is in response to determining that the particular service policy setting needs to be modified, sending configuration information to the wireless end-user device over the service control link, the configuration information configured to assist in modifying or allowing modifications to the particular service policy setting.
2. The method of claim 1, wherein the particular service policy setting assists in implementing a roaming control, a parental control, or an enterprise wireless wide-area network (WWAN) management control.
3. The method of claim 1, wherein the wireless end-user device is an intermediate networking device for forwarding

20

traffic between a wireless wide-area network (WWAN) and a wireless local-area network (WLAN).

4. The method of claim 1, wherein the wireless end-user device is an intermediate networking device comprising a cellular device, the intermediate networking device for forwarding traffic between the wireless access network and a second network.

5. The method of claim 1, wherein the wireless end-user device is an intermediate networking device, and the particular service policy setting assists one or more other end-user devices in communicating over the wireless access network via the intermediate networking device.

6. The method of claim 1, further comprising:

- obtaining a service usage measure, the service usage measure accounting for the one or more communications associated with the wireless end-user device over the wireless access network; and
- based on the service usage measure, taking an action.

7. The method of claim 6, wherein the service usage measure comprises a measure of a service usage activity.

8. The method of claim 6, wherein the action is to verify the service usage measure.

9. The method of claim 6, wherein the action is to quarantine or suspend the wireless end-user device.

10. The method of claim 6, further comprising obtaining secondary information associated with the wireless end-user device, and wherein the action is to verify the service usage measure using the secondary information.

11. The method of claim 1, further comprising receiving, from the wireless end-user device, an integrity report configured to assist a network element in identifying an access control integrity violation.

12. The method of claim 1, wherein the configuration information comprises at least a portion of the service profile.

13. The method of claim 1, wherein the service control link is secured by an encryption protocol.

14. The method of claim 1, wherein the device service state comprises a service profile setting, a service usage policy setting, or a device-assisted services (DAS) setting.

15. The method of claim 1, wherein the device service state provides information about a user preference.

16. The method of claim 1, wherein the device service state comprises information associated with an encryption key.

17. The method of claim 1, wherein the device service state comprises an agent report, a service usage record, a transaction record, or an integrity report.

18. The method of claim 1, wherein the device service state comprises user status information, device status information, application status information, a device location, or a device quality-of-service (QOS) state.

* * * * *