

(19) World Intellectual Property Organization
International Bureau



(43) International Publication Date
24 April 2008 (24.04.2008)

PCT

(10) International Publication Number
WO 2008/048075 A1

- (51) International Patent Classification:
H04Q 7/24 (2006.01)
- (21) International Application Number:
PCT/KR2007/005155
- (22) International Filing Date: 19 October 2007 (19.10.2007)
- (25) Filing Language: Korean
- (26) Publication Language: English
- (30) Priority Data:
10-2006-0101714 19 October 2006 (19.10.2006) KR
- (71) Applicant (for all designated States except US): **INTRO MOBILE CO., LTD.** [KR/KR]; 2502-Ho, ASEM Tower, 159, Samsong-dong, Gangnam-gu, Seoul 135-798 (KR).
- (72) Inventor; and
- (75) Inventor/Applicant (for US only): **LEE, Changseok** [KR/KR]; LG Apt. 101-1602, 12-2, Gaepo-dong, Gangnam-gu, Seoul 135-939 (KR).

- (74) Agent: **JIMYUNG Patent Firm**; 6F, Jungwoo Bldg., 1689-1, Seocho-4-dong, Seocho-gu, Seoul 137-882 (KR).
 - (81) Designated States (unless otherwise indicated, for every kind of national protection available): AE, AG, AL, AM, AT, AU, AZ, BA, BB, BG, BH, BR, BW, BY, BZ, CA, CH, CN, CO, CR, CU, CZ, DE, DK, DM, DO, DZ, EC, EE, EG, ES, FI, GB, GD, GE, GH, GM, GT, HN, HR, HU, ID, IL, IN, IS, JP, KE, KG, KM, KN, KP, KZ, LA, LC, LK, LR, LS, LT, LU, LY, MA, MD, ME, MG, MK, MN, MW, MX, MY, MZ, NA, NG, NI, NO, NZ, OM, PG, PH, PL, PT, RO, RS, RU, SC, SD, SE, SG, SK, SL, SM, SV, SY, TJ, TM, TN, TR, TT, TZ, UA, UG, US, UZ, VC, VN, ZA, ZM, ZW.
 - (84) Designated States (unless otherwise indicated, for every kind of regional protection available): ARIPO (BW, GH, GM, KE, LS, MW, MZ, NA, SD, SL, SZ, TZ, UG, ZM, ZW), Eurasian (AM, AZ, BY, KG, KZ, MD, RU, TJ, TM), European (AT, BE, BG, CH, CY, CZ, DE, DK, EE, ES, FI, FR, GB, GR, HU, IE, IS, IT, LT, LU, LV, MC, MT, NL, PL, PT, RO, SE, SI, SK, TR), OAPI (BF, BJ, CF, CG, CI, CM, GA, GN, GQ, GW, ML, MR, NE, SN, TD, TG).
- Published:**
— with international search report

(54) Title: SYSTEM OF PROVIDING INTEGRATED PUSH SERVICE AND METHOD THEROF

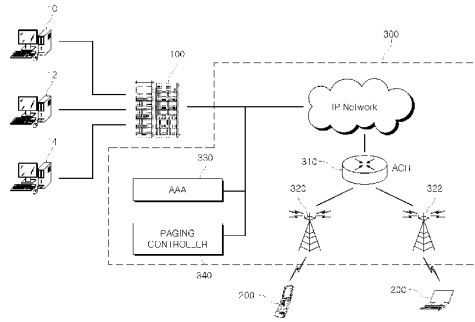

(57) **Abstract:** The present invention relates to a system and a method for providing an integrated push service in an internet service network, and the integrated push service system comprises a plurality of push application servers for providing a push information, the push information including a push data invoked through an application of a mobile terminal, a receiving mobile terminal information specifying the mobile terminal receiving the push data, and an associated application ID specifying the application for invoking the push data; an integrated push service server for receiving the push information and providing the push information to the mobile terminal receiving the push data through an IP push; a mobile internet service network including a plurality of RASs to carry out a communication between the push service server and the mobile terminal receiving the push data; and the mobile terminal for receiving the push information through a mobile internet modem for connecting to the mobile internet service network, the mobile terminal comprising at least one application for associating with the push information, wherein the mobile terminal further comprises a communication session manager resident in a memory thereof, the communication session manager maintaining a communication session with the integrated push service server when the mobile internet modem is connected to the mobile internet service network, and an integrated push service agent for selectively invoking the application compliant to the associated application ID of the received push information to deliver the push data.

WO 2008/048075 A1

Description

SYSTEM OF PROVIDING INTEGRATED PUSH SERVICE AND METHOD THEREOF

Technical Field

- [1] The present invention relates to a system and a method for providing an integrated push service in a network including a mobile internet such as Wibro.

Background Art

- [2] A mobile internet service such as a data service such as WAP (Wireless Application Protocol) based on a mobile communication network such as CDMA2000 1X, 3X, EV-DO, GSM and WCDMA, Wibro (Wireless Broadband) and HPi (High Speed Portable internet) are used to provide a data communication service such as the Internet through a mobile terminal. However, because the mobile communication network is mainly for a voice call and has complex network structure, a cost for building the mobile communication network is high. Therefore, a price per packet is excessive and the mobile communication network is not suitable for the Internet service based on a large capacity multimedia. The mobile internet service is to solve above-described problem wherein a conventional IP network is used to a maximum and a network structure is simple concentrating on a transmission of an IP packet. Therefore, the cost for building the network is low and the price per packet is low. Accordingly, an MBMM (Multiband Multimode) terminal using a conventional CDMA mobile communication modem for the voice call and the mobile internet such as Wibro for a data communication is used.
- [3] On the other hand, a push service is widely used for a sophisticated communication service. The push service actively transmits a data to a client by a server without a user intervention. For instance, an information selected by a user (a news, a stock information and a sports information) is provided to a user terminal in real time or a data for an upgrade is automatically transmitted to the user terminal in order to increase a user convenience.
- [4] However, when the push service is provided via the mobile internet network, problems described below occur.
- [5] First, since a push application server and a push application client should be built for each of the push services, an integrated operation of the network is difficult and a traffic increasing rapidly due to the push service is difficult to manage. In addition, in order to receive the push service in real time, the mobile terminal should load an application or an agent program for each of the push services in a memory. Therefore, a system efficiency is degraded due to a characteristic of the mobile terminal having

limited memory capacity, data processing capacity and battery capacity.

- [6] Second, the mobile terminal enters an idle mode when a data is not transceived considering a mobility of the mobile terminal in case of the mobile internet. In the idle mode, a generation of an unnecessary hand-over traffic is eliminated when moving between base stations in order to minimize a power consumption of the mobile terminal and enable an efficient use of a base station resources. However, in the idle mode, a push data cannot be transmitted to the mobile terminal in real time because the data is not transceived and a connection to a RAS (Radio Access Station) is disengaged.
- [7] Third, since the RAS used in the mobile internet service has a small service coverage compared to a mobile communication base station, a radio frequency shadow area is relatively large and the push data cannot be transmitted in real time when the mobile terminal in the shadow area.

Disclosure of Invention

Technical Problem

- [8] It is an object of the present invention to provide a system and a method for providing an integrated push service wherein various push data generated from a plurality of push application servers are transmitted through an integrated push service server and a mobile terminal extracts an associated application ID app_ID and loads an integrated push service agent selectively invoking a corresponding application to provide the various push services through a mobile internet network, and wherein a separate module for a transmission of the push data is not required for the push service server to reduce a cost for building the push service server, and wherein only a single integrated push service agent is loaded in a memory of the mobile terminal to optimize a system resource of the mobile terminal.
- [9] It is another object of the present invention to provide a system and a method for providing an integrated push service wherein an integrated push service server determines whether a receiving mobile terminal is in an idle mode and a push information is broadcasted via a paging controller provided by a mobile internet service network when the mobile terminal is in the idle mode to provide the push information in real time even to the mobile terminal having a communication session with the integrated push service server terminated in the idle mode.
- [10] It is yet another object of the present invention to provide a system and a method for providing an integrated push service wherein an integrated push service server transmits a push service as an SMS via a mobile communication service network instead of a mobile internet network when a receiving mobile terminal is not connected to the mobile internet network to provide the push information in real time even when

the mobile terminal of a user is in a shadow area of a mobile internet service.

Technical Solution

[11] In order to achieve above-described object, there is provided an integrated push service system comprising: a plurality of push application servers for providing a push information, the push information including a push data invoked through an application of a mobile terminal, a receiving mobile terminal information specifying the mobile terminal receiving the push data, and an associated application ID specifying the application for invoking the push data; an integrated push service server for receiving the push information and providing the push information to the mobile terminal receiving the push data through an IP push; a mobile internet service network including a plurality of RASs to carry out a communication between the push service server and the mobile terminal receiving the push data; and the mobile terminal for receiving the push information through a mobile internet modem for connecting to the mobile internet service network, the mobile terminal comprising at least one application for associating with the push information, wherein the mobile terminal further comprises a communication session manager resident in a memory thereof, the communication session manager maintaining a communication session with the integrated push service server when the mobile internet modem is connected to the mobile internet service network, and an integrated push service agent for selectively invoking the application compliant to the associated application ID of the received push information to deliver the push data.

[12] There is also provided a method for providing an integrated push service comprising steps of: (a) transmitting a push information including a push data invoked through an application of a mobile terminal, a receiving mobile terminal information specifying the mobile terminal receiving the push data and an associated application ID specifying the application for invoking the push data to an integrated push service server through a communication network; (b) transmitting the push information to the receiving mobile terminal via an IP push through a mobile internet service network using the integrated push service server; and (c) receiving the push information using an integrated push service agent resident in a memory of the mobile terminal, and invoking the application compliant to the associated application ID to deliver the push data.

Advantageous Effects

[13] In accordance with the system and the method for providing the integrated push service of the present invention, the various push data generated from the plurality of push application servers are transmitted through the integrated push service server and the mobile terminal extracts the associated application ID app_ID and loads the

integrated push service agent selectively invoking the corresponding application to provide the various push services through the mobile internet network, the separate module for the transmission of the push data is not required for the push service server to reduce the cost for building the push service server, and only the single integrated push service agent is loaded in the memory of the mobile terminal to optimize the system resource of the mobile terminal.

[14] In accordance with the system and the method for providing the integrated push service of the present invention, the integrated push service server determines whether the receiving mobile terminal is in the idle mode and the push information is broadcasted via the paging controller provided by the mobile internet service network when the mobile terminal is in the idle mode to provide the push information in real time even to the mobile terminal having the communication session with the integrated push service server terminated in the idle mode.

[15] In accordance with the system and the method for providing the integrated push service wherein the integrated push service server transmits the push service as the SMS via the mobile communication service network instead of the mobile internet network when the receiving mobile terminal is not connected to the mobile internet network to provide the push information in real time even when the mobile terminal of the user is in the shadow area of the mobile internet service.

Brief Description of the Drawings

[16] Fig. 1 is a diagram illustrating a configuration of an integrated push service system in accordance with an embodiment of the present invention.

[17] Fig. 2 is a diagram illustrating a configuration of an integrated push service server in accordance with an embodiment of the present invention.

[18] Fig. 3 is a diagram illustrating a configuration of an integrated push service agent in accordance with an embodiment of the present invention.

[19] Fig. 4 is a diagram illustrating a hierarchy of an integrated push service agent in accordance with an embodiment of the present invention.

[20] Fig. 5 is a diagram illustrating a configuration of an integrated push service agent in accordance with an embodiment of the present invention.

[21] Figs. 6 through 8 are diagrams illustrating a communication system of a method for providing an integrated push service in accordance with an embodiment of the present invention.

Mode for the Invention

[22] Fig. 1 is a diagram illustrating a configuration of an integrated push service system in accordance with an embodiment of the present invention. Referring to Fig. 1, the integrated push service system comprises a plurality of push application servers 10, 12

and 14, an integrated push service server 100, a mobile internet service network 300, and a mobile terminal 200 including an integrated push service agent 250. The plurality of push application servers 10, 12 and 14 provides a push data to a push service application stored in the mobile terminal 200. The plurality of push application servers 10, 12 and 14 generate the push data push_data such as a real time news data for a news application, a chatting message for a peer-to-peer messenger application and an e-mail message for an e-mail application. A push information push_info including a receiving mobile terminal information specifying the mobile terminal that receives the push data, and an associated application ID app_ID specifying the application for invoking the push data along with the push data is also generated.

[23] In accordance with a conventional push application server, the associated application ID app_ID is not required because the conventional push application server is built for a single push application and a communication session and a protocol are maintained for each of the servers. However, in accordance with the present invention, various push services provided to each of applications are managed in an integrated fashion through the integrated push service server 100 and the integrated push service agent 250. Therefore, the associated application ID app_ID specifying the application for invoking the push data is required.

[24] <Transmission of the push information through an IP push>

[25] The integrated push service server 100 receives the push information push_info from the plurality of push application servers 10, 12 and 14 connected through a communication network, and provides the push information push_info to the mobile terminal 200 through an IP push push_IP. Because the mobile terminal 200 maintains a communication session with the integrated push service server 100 through a CSM (Communication Session Manager) 251 of the integrated push service agent 250, the push information push_info including the push data may be transmitted through the IP push push_IP. When the push information push_info is transmitted through the IP push push_IP, the integrated push service server 100 requests the IP push to the mobile internet service network 300.

[26] The mobile terminal 200 transmits a push information acknowledge message ack_push to the integrated push service server 100 when the push information push_info is received. the integrated push service server 100 acknowledges a successful transmission of the push data by receiving the push information acknowledge message ack_push at a reception acknowledge unit 142. A transmission report manager 140 transmits an information on the reception and a push application service to each of the plurality of push application servers 10, 12 and 14 as a transmission report.

[27] The mobile internet service network 300 is a high speed wireless internet service

such as Wibro and HPi which carries out a communication between the integrated push service server 100 and the mobile terminal 200, transmission/reception of the IP push data push_IP.

[28] The mobile terminal 200 receives the push information push_info in a form of the IP push push_IP through a mobile internet modem 210 for connecting to the mobile internet service network 300, and includes at least one application 260 that is to be associated with the push information push_info. Particularly, the mobile terminal 200 includes the integrated push service agent 250. The integrated push service agent 250 includes the CSM 251 resident on a memory of the mobile terminal 200 that maintains the communication session with the integrated push service server 100 in a state that the mobile internet modem 210 is connected to the mobile internet service network 300, and selectively invokes the application 260 compliant to the associated application ID app_ID of the push information push_info to deliver the push data.

[29] When an entirety of the applications 260 supporting a plurality of push services such as a chatting service, a mail service, a news service and a stock service in the mobile terminal 200 are resident in the memory in order to correspond to individual IP push in accordance with conventional art, a system resources of the mobile terminal 200 may be overloaded to degrade a processing speed thereof and is wasted. However, as shown in Fig. 3, only the integrated push service agent 250 of the mobile terminal 200 is resident in the memory of the mobile terminal 200 with each of the applications 260 being inactive in accordance with the embodiment of the present invention while an IP push receiver 252 receives the push information push_info for the entirety of the applications in an integrated fashion and uses the associated application ID app_ID included in the push information push_info to selectively invoke the application 260 corresponding to the associated application ID app_ID, thereby reducing a number of the applications resident in the memory and a power consumption of the mobile terminal 200.

[30] <Transmission of push information via paging message>

[31] On the other hand, a mobile internet service generally supports a power saving mode in order to reduce power consumption in a mobile environment. The mobile terminal 200 typically updates to which RAS 320 of a plurality of RASs 320 and 322 through a constant communication and a hand-over with the RASs 320 and 322. However, an unnecessary power consumption occurs for the mobile terminal 200 that does not have a constant transmission/reception of a data in order to maintain the constant communication with the mobile internet service network 300 for the hand-over and a registration of the RAS. As a result, the unnecessary power consumption has a serious effect on a DBDM(dual-band dual-mode) terminal using both the mobile internet service network 300 and a mobile communication service network 400 such as

a CDMA and a GSM or MBMM(multi-band multi-mode) terminal supporting three or more communication services.

- [32] The power saving mode provided by the mobile internet service is to solve above-described problem. In the power saving mode, the mobile terminal 200 enters an idle mode wherein a connection to the RAS 320 is lost when an exchange of the data with a mobile internet network is not carried out for more than a predetermined time. The idle mode refers to a state that the transmission/reception of the data by the mobile terminal 200 is not carried out and the connection to the RAS 320 is lost to eliminate a generation of an unnecessary hand-over traffic between the mobile terminal 200 and the RASs 320 and 322, thereby minimizing the power consumption of the mobile terminal 200 and enabling an efficient use of the RASs 320 and 322.
- [33] When a packet to be transmitted to the mobile terminal 200 is generated in the idle mode, a paging controller 340 of the mobile internet service network 300 broadcasts a paging message through the RASs 320 and 322 of a paging group consisting of the plurality of RASs wherein the mobile terminal 200 expected to exist. Through this process, the mobile terminal 200 receives a downlink data packet to exit the idle mode and enter a normal mode to re-connect to the mobile internet service network 300.
- [34] In accordance with the embodiment of the present invention, a push service may be provided continuously for the mobile terminal 200 in the idle mode by transmitting the push information through the paging message. When the mobile terminal 200 enters the idle mode, the CSM 251 of the integrated push service agent 250 of the mobile terminal 200 cannot send the push information push_info through the IP push push_IP because the communication session with the integrated push service server 100 is terminated. While the integrated push service server 100 may schedule and transmit the push information push_info or re-transmit the push information push_info by recognizing a communication configuration of the mobile terminal 200, the push service cannot be provided in real time.
- [35] It is preferable that the push information push_info is included in the paging message instead of the IP push push_IP such that the push service is provided to the mobile terminal 200 in real time in order to solve above-described problem.
- [36] There are two methods for the mobile terminal 200 to recognize the idle mode of the mobile terminal 200. In accordance with a first method, whether the mobile terminal 200 is in the idle mode is registered in a presence server 130 such that the integrated push service server 100 may inquire the presence server 130 of whether the mobile terminal 200 is in the idle mode prior to transmitting the push information push_info. In accordance with a second method, the integrated push service server 100 transmits the push information push_info by the IP push push_IP and determines that the mobile terminal 200 is in the idle mode when the push information acknowledge

message ack_push is not received from the mobile terminal 200.

- [37] While a configuration of the integrated push service server 100 is complex due to an association with the presence server 130, an unnecessary IP push is omitted to enable an efficient use of a network resource in accordance with the first method. While an unnecessary traffic is generated due to the IP push push_IP, the integrated push service server 100 does not require the association with the presence server 130, thereby simplifying a system configuration in accordance with the second method.
- [38] The first method wherein the presence server 130 is used is described below in detail.
- [39] In accordance with first method, the integrated push service server 100 or the mobile internet service network 300 further includes the presence server 130 that determines whether the mobile terminal 200 is in the idle mode, and also further comprises the paging controller 340 for broadcasting the paging message for the mobile terminal 200 through the at least one RASs 320 and 322. The integrated push service server 100 provides the push information push_info to the paging controller 340 when the mobile terminal 200 is determined to be in the idle mode using the presence server 130, and the integrated push service agent further comprises a paging message parser 253 for parsing the push information push_info when the push information push_info is received as the paging message push_paging.
- [40] In accordance with first method, the integrated push service server 100 inquires the presence server 130 of whether the mobile terminal 200 is in the idle mode and transmits the push information push_info as the paging message push_paging through the paging controller 340 instead of the IP push push_IP in the idle mode. The mobile terminal 200 extracts the push data push_data and the associated application ID app_ID from the paging message push_paging through the paging message parser 253 as the paging message push_paging is received. The corresponding application 260 is then invoked to provide various push services between the plurality of push application servers 10, 12 and 14 and the mobile terminal 200.
- [41] The second method wherein the presence server 130 is not used is described below in detail.
- [42] In accordance with second method, the integrated push service agent 250 further comprises a reception acknowledge report manager 256 for generating the push information acknowledge message ack_push, and the mobile internet service network 300 further comprises the paging controller 340 for broadcasting the paging message for the mobile terminal 200 through the at least one RASs 320 and 322. The integrated push service server 100 provides the push information push_info to the paging controller 340 when the push information acknowledge message ack_push is not received from the reception acknowledge report manager 256, and the mobile terminal

200 is configured to further include the paging message parser 253 for parsing for parsing the push information push_info when the push information push_info is received as the paging message push_paging.

[43] In accordance with second method, the integrated push service server 100 transmits the push information push_info via the IP push push_IP and determines that the mobile terminal 200 is in the idle mode when the push information acknowledge message ack_push is not received. The mobile terminal 200 extracts the push data push_data and the associated application ID app_ID from the paging message push_paging through the paging message parser 253 as the paging message push_paging is received. The corresponding application 260 is then invoked to provide various push services between the plurality of push application servers 10, 12 and 14 and the mobile terminal 200.

[44] In accordance with the embodiment wherein the push information push_info is transmitted through the paging message push_paging, it preferable that the CSM 251 of the integrated push service agent 250 of the mobile terminal 200 controls the mobile internet modem 210 to configure the communication session between the integrated push service server 100 and the integrated push service agent 250. In case that the push data push_data is too large to be transmitted efficiently by only the paging message push_paging or that other data is to be transmitted after the transmission of the push information push_info, the mobile terminal 200 automatically exits the idle mode to configure the communication session with the integrated push service server 100 when the push information push_info is received as the paging message push_paging, thereby efficiently providing the push service.

[45] <Transmission of push information through SMS of service network>

[46] Since the mobile internet service is designed for a data communication, the mobile internet service is disadvantageous over the mobile communication service such as CDMA and GSM. Considering the disadvantage, a DBDM terminal or a MBMM terminal supporting both the mobile communication service and the mobile internet service is used. In such case, the mobile terminal 200 includes the mobile internet modem 210 and a mobile communication modem 220.

[47] However, in accordance with embodiment, while the mobile internet modem 210 maintains the communication with the mobile communication service network 400 in order to receive an incoming call, a communication with the mobile internet service network 300 for the data communication is established selectively when required by a user. In addition, since the mobile internet service network 300 has a small service coverage compared to the mobile communication service network 400, the communication with the mobile communication service network 400 is frequently terminated when the mobile terminal 200 enters a shadow area.

- [48] When the mobile terminal 200 is unable to establish the communication with the mobile communication service network 400, the push data push_data cannot be transmitted via the IP push push_IP or the paging message push_paging even when a new push data push_data is generated in a push application server 10.
- [49] In such case, the integrated push service agent 250 connects to the paging controller 340 and informs the integrated push service server 100 of the mobile terminal 200 entering the network once connected to the mobile internet service network 300. the integrated push service server 100 searches whether the push information push_info that is not transmitted to the mobile terminal 200 exists to transmit the push information push_info as the IP push push_IP or the paging message push_paging. However, the push service is not provided in real time even in accordance with the embodiment.
- [50] In order to solve above-described problem, the integrated push service system further comprises the mobile communication service network 400 including a plurality of base stations and a SMSC, the mobile terminal 200 further comprises the mobile communication modem 220 for connecting to the mobile communication service network 400, the integrated push service server 100 transmits the push information push_info to the SMSC of the mobile communication service network 400 when the mobile terminal 200 is determined to be disconnected from the mobile internet service network, and the integrated push service agent 250 further comprises an SMS parser 254 for parsing the push information push_info when the push information push_info is received via an SMS push_SMS through the mobile communication modem 250.
- [51] In accordance with the embodiment, a real time push service is possible since the push information push_info may be transmitted via the SMS push_SMS even when the mobile terminal 200 is not connected to the mobile internet service network 300.
- [52] On the other hand, in a certain case, the push data push_data should be transmitted to the application 260 using a data service provided by the mobile communication service network 400 such as WAP (wireless Application Protocol) instead of the application 260 using the mobile internet service network 300. Typically, a method wherein a connection to a data network of a corresponding mobile communication service via the SMS is used. In such case, the integrated push service agent 250 may be configured to further include a mobile communication service interface. The integrated push service agent 250 further comprises the mobile communication service interface for controlling the mobile communication modem 220 to connect to the data network provided by the mobile communication service network 400, and may be configured to control the mobile communication modem 220 to connect to the data network of the mobile communication service network when the associated application ID app_ID of the received push information push_info designates the application 260 associated with

the data network of the mobile communication service network 400.

[53] <Method for providing integrated push service>

[54] Figs. 6 through 8 are diagrams illustrating a communication system of a method for providing an integrated push service in accordance with an embodiment of the present invention.

[55] First steps (S100 and S120) are carried out wherein a push information push_info including a push data push_data invoked through an application of a mobile terminal, a receiving mobile terminal information specifying the mobile terminal receiving the push data push_data and an associated application ID app_ID specifying the application for invoking the push data push_data is transmitted to an integrated push service server through a communication network.

[56] Thereafter, second steps S200 and S210 are carried out wherein a integrated push service server 100 transmits the push information push_info to the receiving mobile terminal 200 via an IP push through a mobile internet service network 300.

[57] Thereafter, third steps S500 and S600 are carried out wherein an integrated push service agent 250 resident in a memory of the mobile terminal 200 receives the push information push_info (S500) and invokes an application 260 compliant to the associated application ID app_ID to deliver the push data push_data.

[58] The embodiment is described in detail wherein the push information push_info is transmitted as a paging message push_message in order to provide the integrated push service even when the mobile terminal 200 is in an idle mode.

[59] First, the method for providing the integrated push service further comprises a fourth step wherein a presence server 130 detects the idle mode of the mobile terminal 200 prior to the first steps S100 and S120, the second steps S200 and S210 further comprises a first sub-step S305 wherein the push information push_info is requested to a paging controller 340 of the mobile internet service network 300 to be transmitted as the paging message push_paging when the mobile terminal 200 is determined to be in the idle mode, and a second sub-step S310 wherein the paging controller 340 broadcasts the push information push_info as the paging message push_paging through at least one RASs 320 and 211, and the third step S600 may be configured in a manner that the integrated push service agent 250 parses the paging message push_paging to extract the push information push_info.

[60] In accordance with the embodiment shown in Fig. 7 wherein the presence server 130 is not used, the third step further comprises a third sub-step (S700) wherein the integrated push service agent 250 transmits a reception acknowledge message ack_push to the integrated push service server according to the reception of the push information push_info, the second steps S200 and S210 further comprises a first sub-step S305 of requesting a paging controller of the mobile internet service network to

transmit the push information push_info as the paging message push_paging when the reception acknowledge message is not received and a fifth sub-step S310 wherein the paging controller 340 broadcasts the push information push_info as the paging message push_paging through at least one RASs 320 and 322, and the third step S600 may be configured to in a manner that the integrated push service agent 250 parses the paging message push_paging to extract the push information push_info.

- [61] After carrying out the third step S600, the integrated push service agent 250 may further establish a communication session with the integrated push service server according to the reception of the push information push_info.
- [62] Finally, an embodiment of the method for providing the integrated push service using the SMS wherein the mobile terminal 200 is a DBDM terminal that may connect to the mobile internet service network 300 and the mobile communication service network 400 and the mobile terminal 200 is not connected to the mobile internet service network 300 to provide the integrated push service in real time is described below in detail.
- [63] As shown in Fig. 8, the second steps S200 and S210 comprises a sixth sub-step wherein the push information push_info is transmitted to an SMSC of the mobile communication service network 400 when the mobile terminal 200 is determined to be disconnected from the mobile internet service network 300 and a seventh sub-step wherein the SMSC transmits the push information push_info to the receiving mobile terminal 200 as the SMS push_SMS, and the third steps S500 and S600 further comprises an eighth sub-step wherein the integrated push service agent 250 parses the received SMS push_SMS to extract the push information push_info.
- [64] While the present invention has been particularly shown and described with reference to the preferred embodiment thereof, it will be understood by those skilled in the art that various changes in form and details may be effected therein without departing from the spirit and scope of the invention as defined by the appended claims.

Claims

- [1] An integrated push service system comprising:
a plurality of push application servers for providing a push information, the push information including a push data invoked through an application of a mobile terminal, a receiving mobile terminal information specifying the mobile terminal receiving the push data, and an associated application ID specifying the application for invoking the push data;
an integrated push service server for receiving the push information and providing the push information to the mobile terminal receiving the push data through an IP push;
a mobile internet service network including a plurality of RASs to carry out a communication between the push service server and the mobile terminal receiving the push data; and
the mobile terminal for receiving the push information through a mobile internet modem for connecting to the mobile internet service network, the mobile terminal comprising at least one application for associating with the push information,
wherein the mobile terminal further comprises a communication session manager resident in a memory thereof, the communication session manager maintaining a communication session with the integrated push service server when the mobile internet modem is connected to the mobile internet service network, and an integrated push service agent for selectively invoking the application compliant to the associated application ID of the received push information to deliver the push data.
- [2] The system in accordance with claim 1, wherein the integrated push service server or the mobile internet service network further comprises a presence server for detecting an idle mode of the mobile terminal,
wherein the mobile internet service network further comprises a paging controller for broadcasting a paging message for the mobile terminal through the at least one RAS,
wherein the integrated push service server provides the push information to the paging controller when the mobile terminal is determined to be in the idle mode through the presence server, and
wherein the integrated push service agent further comprises a paging message parser for parsing the push information when the push information is received as the paging message.
- [3] The system in accordance with claim 1, wherein the integrated push service

agent further comprises a reception acknowledge report manager for generating a push information reception acknowledge message according to the reception of the push information,

wherein the mobile internet service network further comprises a paging controller for broadcasting a paging message for the mobile terminal through the at least one RAS,

wherein the integrated push service server provides the push information to the paging controller when the push information reception acknowledge message is not received from the reception acknowledge report manager after transmitting the push message via an IP push, and

wherein the mobile terminal further comprises a paging message parser for parsing the push information when the push information is received as the paging message.

- [4] The system in accordance with one of claims 2 and 3, wherein the communication session manager establishes a communication session between the integrated push service server and the integrated push service agent by controlling the mobile internet modem when the push information is received as the paging message.
- [5] The system in accordance with one of claims 2 and 3, wherein the integrated push service server stores the push information when the mobile terminal is not connected to the mobile internet service network and transmits the stored push information when the mobile terminal is connected to the mobile internet service network.
- [6] The system in accordance with claim 5, wherein the integrated push service agent informs the integrated push service server of an entrance to the mobile internet service network via the paging message by connecting to the paging controller when connected to the mobile internet service network.
- [7] The system in accordance with one of claims 1 through 3, further comprising a mobile communication service network including a plurality of base stations and a SMSC,
 wherein the mobile terminal further comprises a mobile communication modem for connecting to the mobile communication service network,
 wherein the integrated push service server transmits the push information to the SMSC of the mobile communication service network when the mobile terminal is determined to be disconnected from the mobile internet service network, and
 wherein the integrated push service agent further comprises an SMS parser for parsing the push information when the push information is received via an SMS through the mobile communication modem.

- [8] The system in accordance with claim 7, wherein the integrated push service agent the integrated push service agent further comprises a mobile communication service interface for controlling the mobile communication modem to connect to a data network provided by the mobile communication service network, and controls the mobile communication modem to connect to the data network of the mobile communication service network when the associated application ID of the received push information designates the application associated with the data network of the mobile communication service network.
- [9] The system in accordance with one of claims 1 through 3, wherein the integrated push service server further comprises a transmission report manager for generating a transmission report including a result of a push information transmission, and transmits the result of the push information transmission to the push application server providing the push information.
- [10] A method for providing an integrated push service comprising steps of:
(a) transmitting a push information including a push data invoked through an application of a mobile terminal, a receiving mobile terminal information specifying the mobile terminal receiving the push data and an associated application ID specifying the application for invoking the push data to an integrated push service server through a communication network;
(b) transmitting the push information to the receiving mobile terminal via an IP push through a mobile internet service network using the integrated push service server; and
(c) receiving the push information using an integrated push service agent resident in a memory of the mobile terminal, and invoking the application compliant to the associated application ID to deliver the push data.
- [11] The method in accordance with claim 10, further comprising (d) detecting an idle mode of the mobile terminal by a presence server prior to the step (a), wherein the step (b) further comprises:
(a-1) requesting the push information as a paging message using a paging controller of the mobile internet service network when the mobile terminal is determined to be in the idle mode; and
(a-2) broadcasting the push information as the paging message through at least one RAS using the paging controller, and
wherein the step (c) comprises extracting the push information by parsing the paging message using the integrated push service agent.
- [12] The method in accordance with claim 10, wherein the step (c) further comprises (c-1) transmitting a reception acknowledge message to the integrated push service server according to the reception of the push information using the

integrated push service agent,

wherein the step (b) further comprises:

(b-1) requesting a paging controller of the mobile internet service network to transmit the push information as the paging message when the reception acknowledge message is not received; and

(b-2) broadcasting the push information as the paging message through at least one RAS using the paging controller, and

wherein the step (c) extracting the push information by parsing the paging message using the integrated push service agent.

- [13] The method in accordance with one of claims 11 and 12, wherein further comprising (e) establishing a communication session between the integrated push service server and the integrated push service agent according to the reception of the push information after carrying out the step (c).
- [14] The method in accordance with one of claims 11 and 12, wherein the step (b) comprises storing the push information when the mobile terminal is not connected to the mobile internet service network, and re-transmitting the stored push information when the mobile terminal is connected to the mobile internet service network.
- [15] The method in accordance with one of claims 11 and 12, wherein the step (b) comprises:
- (b-3) transmitting the push information to a SMSC of the mobile internet service network when the mobile terminal is determined to be disconnected from the mobile internet service network; and
- (b-4) transmitting the push information to the receiving mobile terminal as an SMS by the SMCC, and
- wherein the step (c) further comprises (c-2) extracting the push information by parsing the SMS by the integrated push service agent.

[Fig. 1]

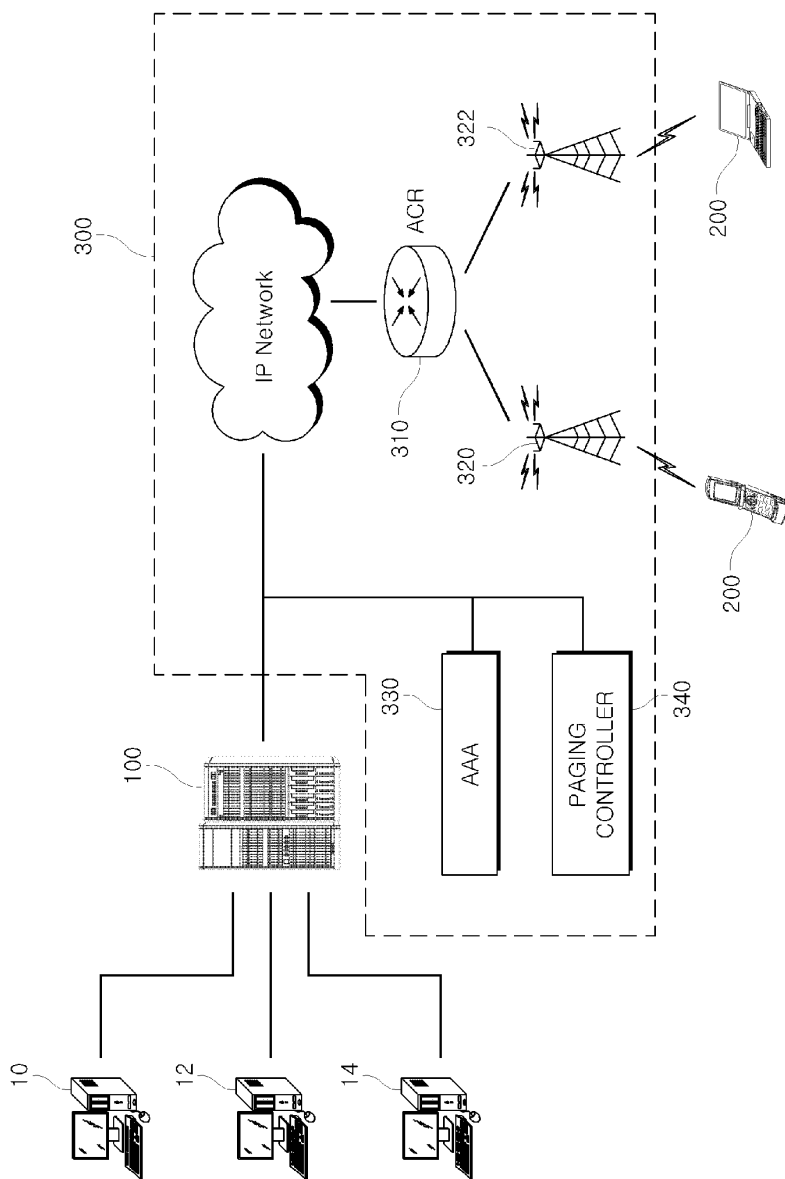

[Fig. 2]

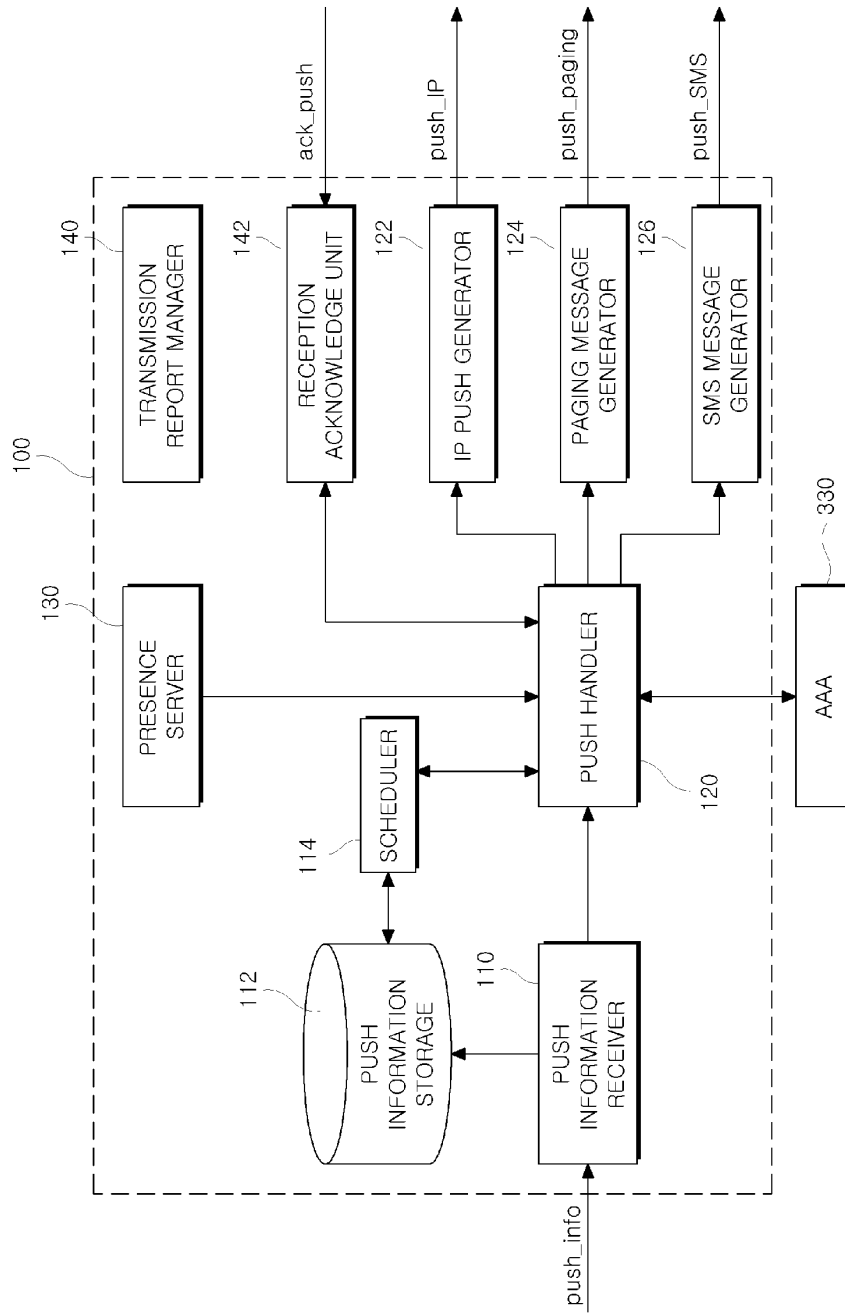

[Fig. 3]

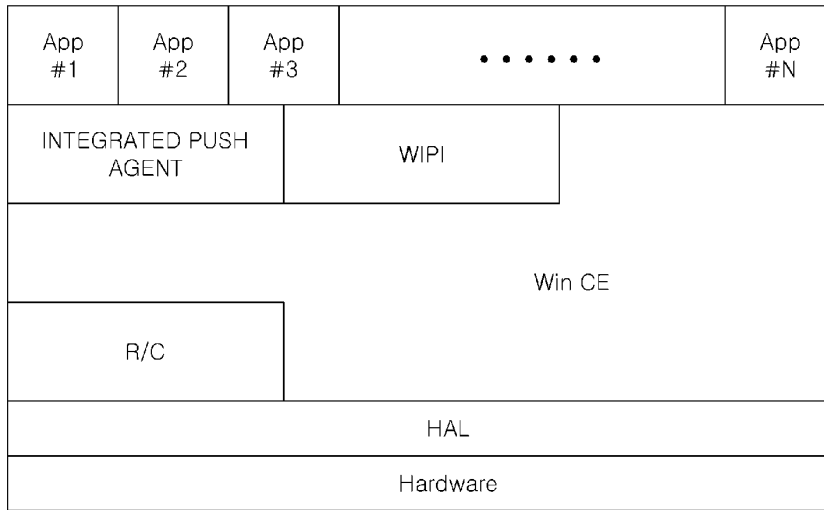

[Fig. 4]

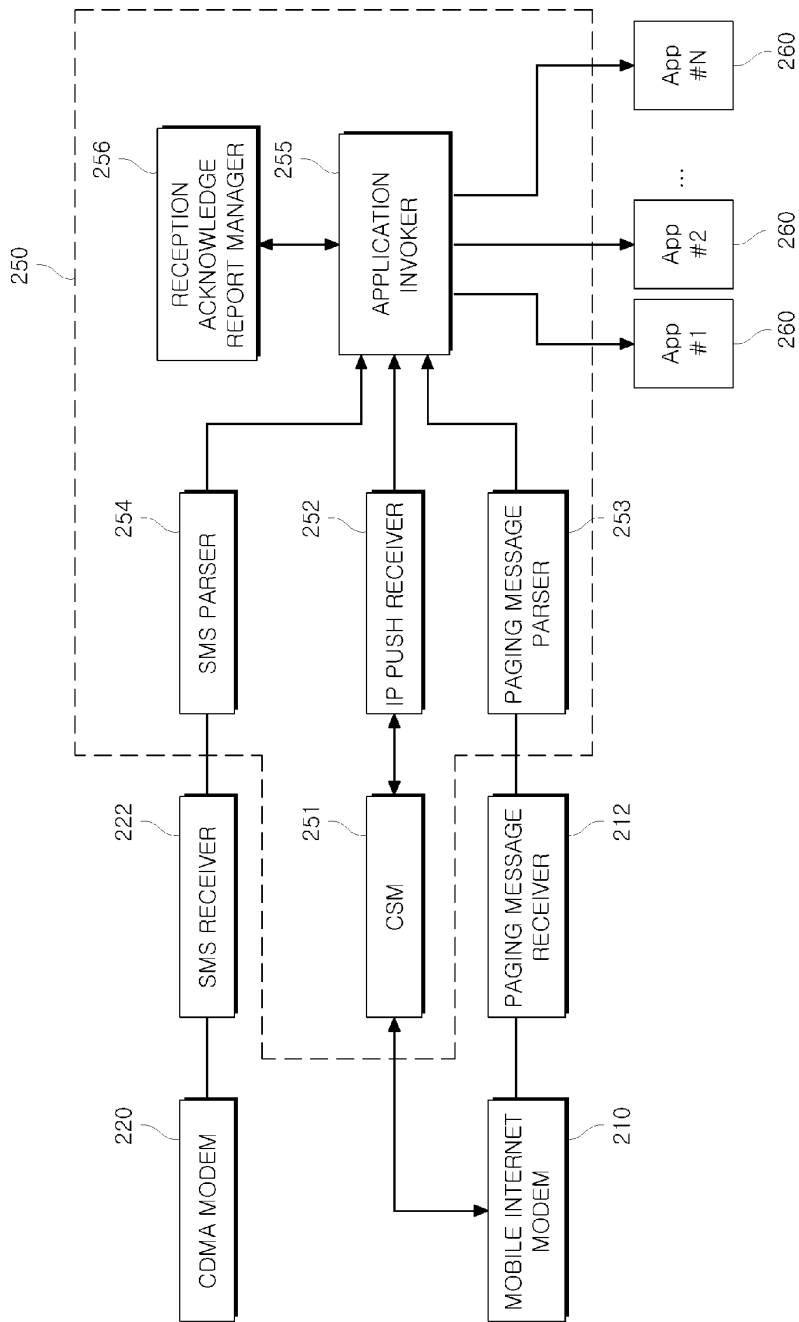

[Fig. 5]

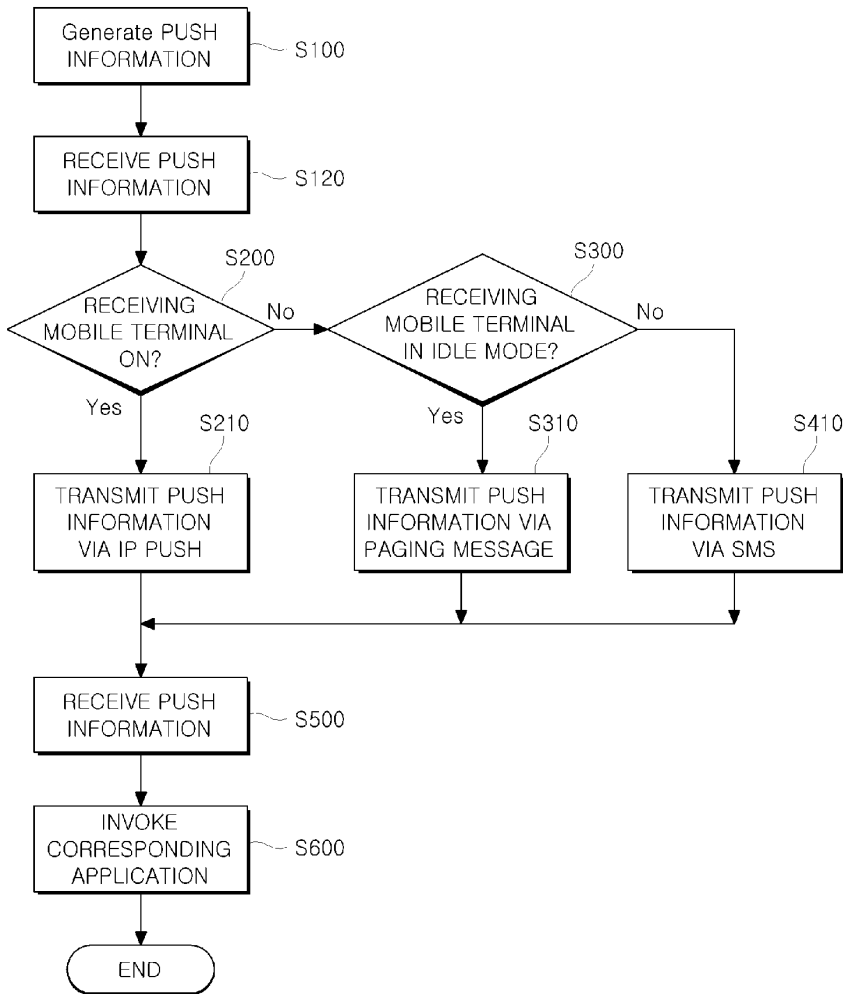

[Fig. 6]

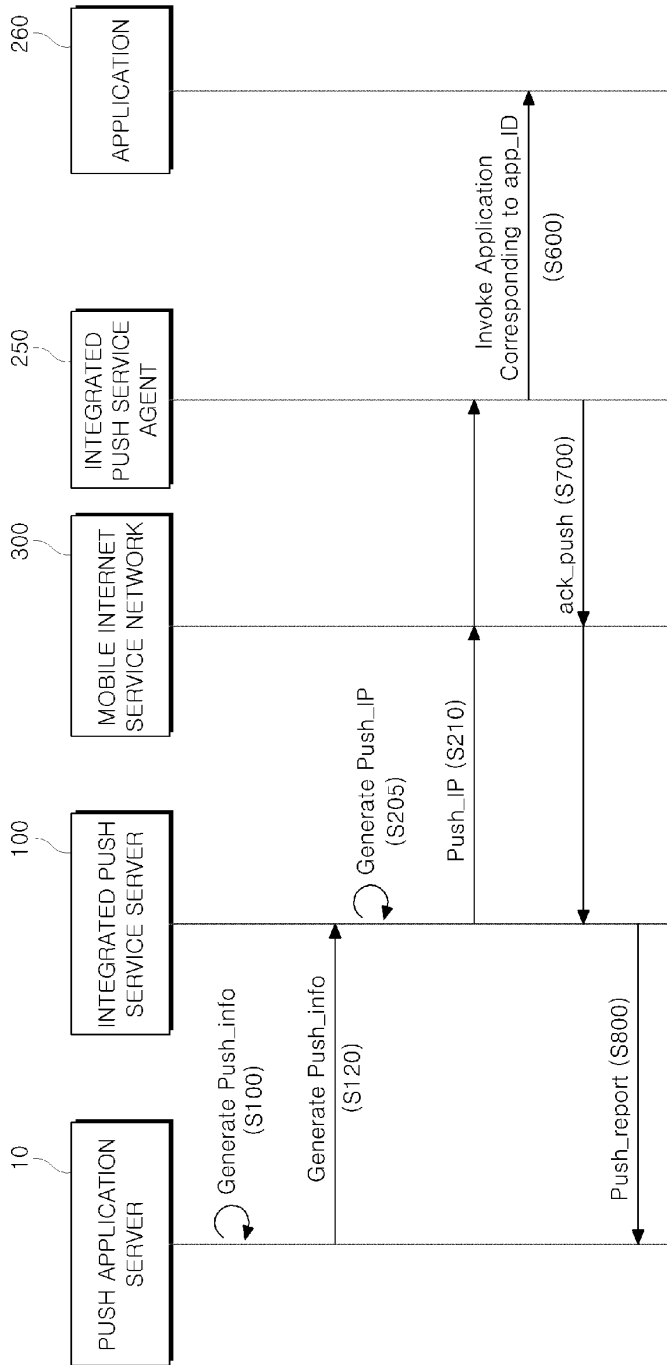

[Fig. 7]

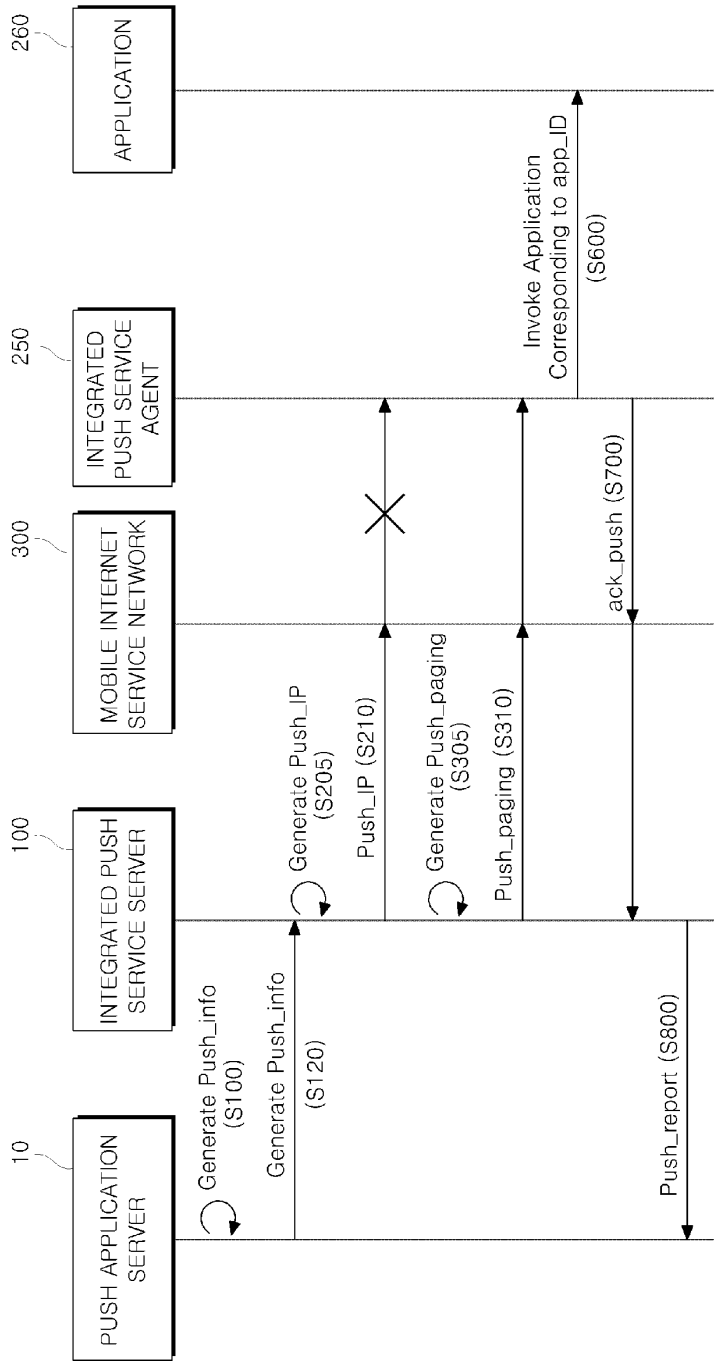

[Fig. 8]

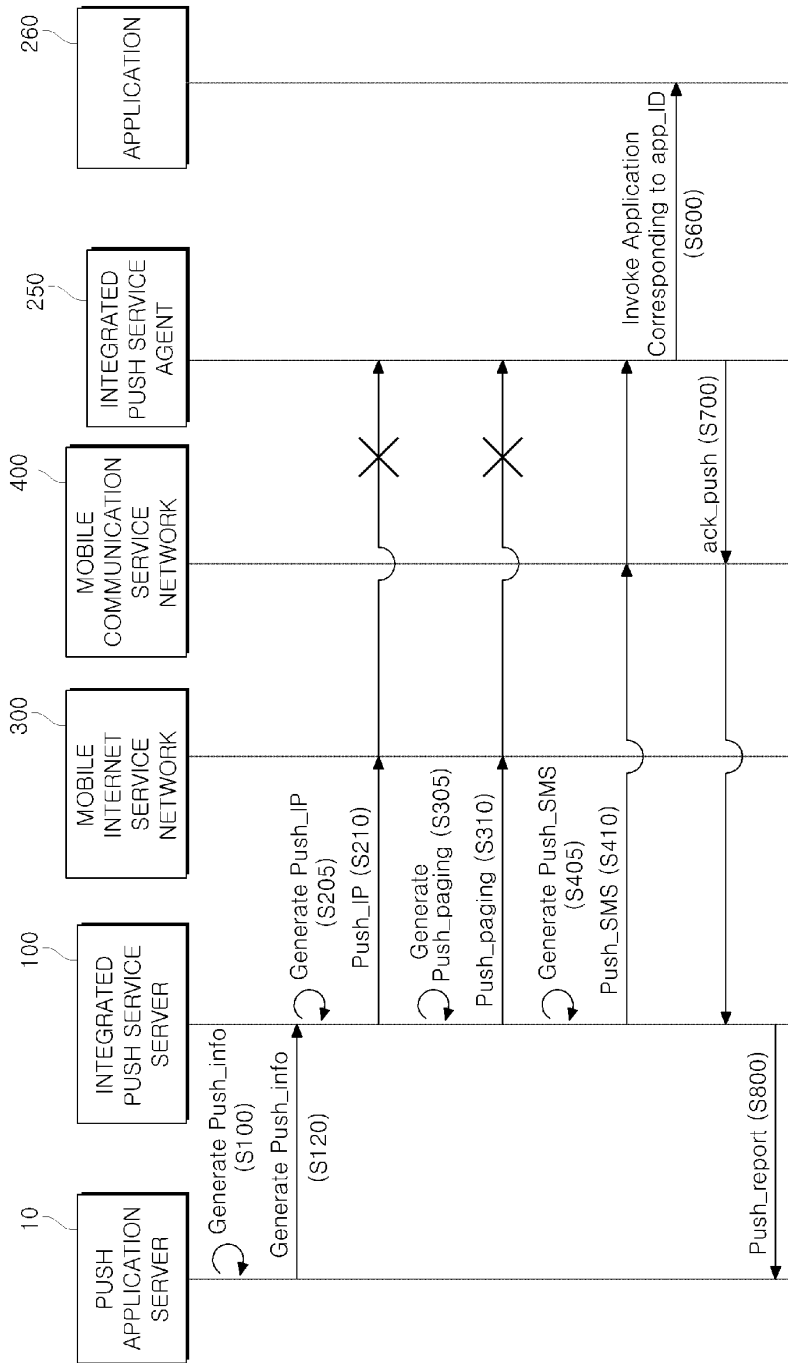

INTERNATIONAL SEARCH REPORT

International application No.
PCT/KR2007/005155

A. CLASSIFICATION OF SUBJECT MATTER

H04Q 7/24(2006.01)i

According to International Patent Classification (IPC) or to both national classification and IPC

B. FIELDS SEARCHED

Minimum documentation searched (classification system followed by classification symbols)

IPC 8 : H04Q 7/24

Documentation searched other than minimum documentation to the extent that such documents are included in the fields searched

Korean Utility models and applications for Utility Models since 1975
Japanese Utility models and applications for Utility Models since 1975

Electronic data base consulted during the international search (name of data base and, where practicable, search terms used)

eKIPASS(KIPO internal) "push, application, server, agent"

C. DOCUMENTS CONSIDERED TO BE RELEVANT

Category*	Citation of document, with indication, where appropriate, of the relevant passages	Relevant to claim No.
A	US 06999991 B1 (Ikeda, H.) 14 Feb. 2006 See abstract, figures 1-2, claims 1-9, and column 6, line 53 - column 8, line 5	1-15
A	US 2002-0116472 A1 (Kalish, D. et al.) 22 Aug. 2002 See abstract, figures 1-2, claims 1-10, and paragraphs [0020]-[0032]	1-15
A	KR 10-2003-0037448 A (SK TELECOM CO., LTD.) 14 May 2003 See abstract, figure 2, claims 1-5, and page 3, lines 20-47	1-15
A	KR 10-2004-0045803 A (WIDERTHAN.COM CO., LTD.) 02 Jun. 2004 See abstract, figures 3-4, claims 1-4, and page 4, line 57 - page 6, line 9	1-15
A	KR 10-2005-0064905 A (LG ELECTRONICS INC.) 29 Jun. 2005 See abstract, figure 3, claims 1-3, and page 3, lines 1-15	1-15
A	KR 10-2001-0008959 A (SK TELECOM CO., LTD.) 05 Feb. 2001 See abstract, figures 1-2, claims 1-6, and page 3, line 11 - page 4, line 4	1-15

Further documents are listed in the continuation of Box C.

See patent family annex.

* Special categories of cited documents:

"A" document defining the general state of the art which is not considered to be of particular relevance

"E" earlier application or patent but published on or after the international filing date

"L" document which may throw doubts on priority claim(s) or which is cited to establish the publication date of citation or other special reason (as specified)

"O" document referring to an oral disclosure, use, exhibition or other means

"P" document published prior to the international filing date but later than the priority date claimed

"T" later document published after the international filing date or priority date and not in conflict with the application but cited to understand the principle or theory underlying the invention

"X" document of particular relevance; the claimed invention cannot be considered novel or cannot be considered to involve an inventive step when the document is taken alone

"Y" document of particular relevance; the claimed invention cannot be considered to involve an inventive step when the document is combined with one or more other such documents, such combination being obvious to a person skilled in the art

"&" document member of the same patent family

Date of the actual completion of the international search

26 DECEMBER 2007 (26.12.2007)

Date of mailing of the international search report

27 DECEMBER 2007 (27.12.2007)

Name and mailing address of the ISA/KR



Korean Intellectual Property Office
920 Dunsan-dong, Seo-gu, Daejeon 302-701,
Republic of Korea

Facsimile No. 82-42-472-7140

Authorized officer

KIM, Kwang Sik

Telephone No. 82-42-481-8355



INTERNATIONAL SEARCH REPORT

Information on patent family members

International application No.

PCT/KR2007/005155

Patent document cited in search report	Publication date	Patent family member(s)	Publication date
US 06999991 B1	14.02.2006	None	
US 20020116472 A1	22.08.2002	W02003088064A1	23.10.2003
KR 1020030037448 A	14.05.2003	None	
KR 1020040045803 A	02.06.2004	None	
KR 1020050064905 A	29.06.2005	None	
KR 1020010008959 A	05.02.2001	None	