



US008809139B2

(12) **United States Patent**
Huang et al.

(10) **Patent No.:** **US 8,809,139 B2**
(45) **Date of Patent:** **Aug. 19, 2014**

(54) **FIN-LAST FINFET AND METHODS OF FORMING SAME**

2007/0004133	A1*	1/2007	Kim et al.	438/253
2009/0061586	A1	3/2009	Yu et al.	
2011/0291189	A1	12/2011	Cheng et al.	
2013/0270628	A1	10/2013	Huang et al.	
2014/0027816	A1*	1/2014	Cea et al.	257/192

(71) Applicant: **Taiwan Semiconductor Manufacturing Company, Ltd.**, Hsin-Chu (TW)

(72) Inventors: **Yu-Lien Huang**, Jhubei (TW);
Ming-Huan Tsai, Hsin-Chu (TW);
Clement Hsingjen Wann, Carmel, NY (US)

(73) Assignee: **Taiwan Semiconductor Manufacturing Company, Ltd.**, Hsin-Chu (TW)

(*) Notice: Subject to any disclaimer, the term of this patent is extended or adjusted under 35 U.S.C. 154(b) by 0 days.

(21) Appl. No.: **13/689,346**

(22) Filed: **Nov. 29, 2012**

(65) **Prior Publication Data**

US 2014/0145242 A1 May 29, 2014

(51) **Int. Cl.**
H01L 21/336 (2006.01)
H01L 21/8234 (2006.01)

(52) **U.S. Cl.**
USPC **438/197**; 257/E21.176; 257/E21.294;
257/E21.429; 257/E21.544; 438/283; 438/300;
438/589

(58) **Field of Classification Search**
USPC 257/E21.176, E21.294, E21.409,
257/E21.429, E21.544; 438/197, 283, 300,
438/589
See application file for complete search history.

(56) **References Cited**

U.S. PATENT DOCUMENTS

7,579,248 B2 8/2009 Huang et al.
2006/0113591 A1 6/2006 Wan et al.

OTHER PUBLICATIONS

Fitzgerald, E.A. et al., "MOSFET Channel Engineering using Strained Si, SiGe, and Ge Channels," MIT, Department of Materials Science and Engineering, Jan. 2003, 1 page.

Liao, W.S. et al., "PMOS Hole Mobility Enhancement Through SiGe Conductive Channel and Highly Compressive ILD-SiNx Stressing Layer," IEEE Electron Device Letters, vol. 29, No. 1, Jan. 2008, pp. 86-88.

Shi, Z. et al., "Mobility Enhancement in Surface Channel SiGe PMOSFETs with HfO2 Gate Dielectrics," IEEE Electron Device Letters, vol. 24, No. 1, Jan. 2003, pp. 34-36.

(Continued)

Primary Examiner — Asok K Sarkar

(74) *Attorney, Agent, or Firm* — Slater and Matsil, L.L.P.

(57) **ABSTRACT**

Embodiments of the present disclosure are a FinFET device, and methods of forming a FinFET device. An embodiment is a method for forming a FinFET device, the method comprising forming a semiconductor strip over a semiconductor substrate, wherein the semiconductor strip is disposed in a dielectric layer, forming a gate over the semiconductor strip and the dielectric layer, and forming a first recess and a second recess in the semiconductor strip, wherein the first recess is on an opposite side of the gate from the second recess. The method further comprises forming a source region in the first recess and a drain region in the second recess, and recessing the dielectric layer, wherein a first portion of the semiconductor strip extends above a top surface of the dielectric layer forming a semiconductor fin.

20 Claims, 24 Drawing Sheets

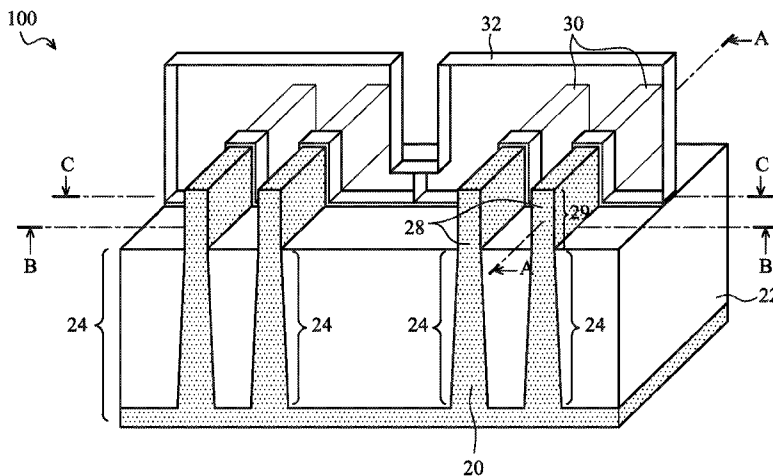

(56)

References Cited

OTHER PUBLICATIONS

Verdonckt-Vandebroek, S. et al., "High-Mobility Modulation-Doped Graded SiGe-Channel p-MOSFET's," IEEE Electron Device Letters, vol. 12, No. 8, Aug. 1991, pp. 447-449.

Xia, G., "SiGe and Stress Technology for CMOS and Beyond," UBC, Materials Engineering, MiNA Microsystems and Nanotechnology Group, Sep. 15, 2009, 35 pages.

Hashemi, P. et al., "Ultrathin Strained-Ge Channel P-MOSFETs With High-K/Metal Gate and Sub-1-nm Equivalent Oxide Thickness," IEEE Electron Device Letters, vol. 33, Issue 7, Jul. 2012, pp. 943-945.

* cited by examiner

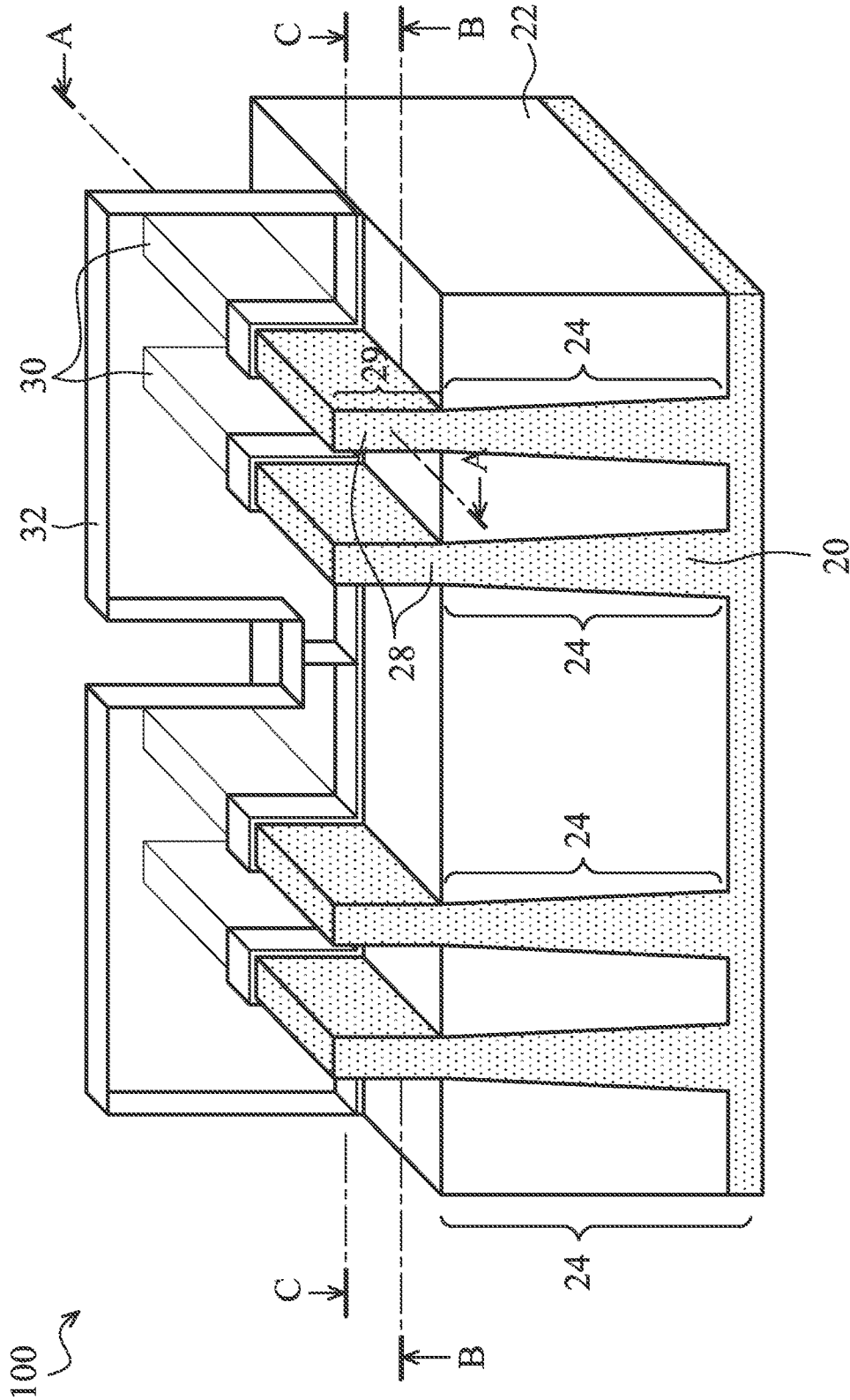

Fig 1

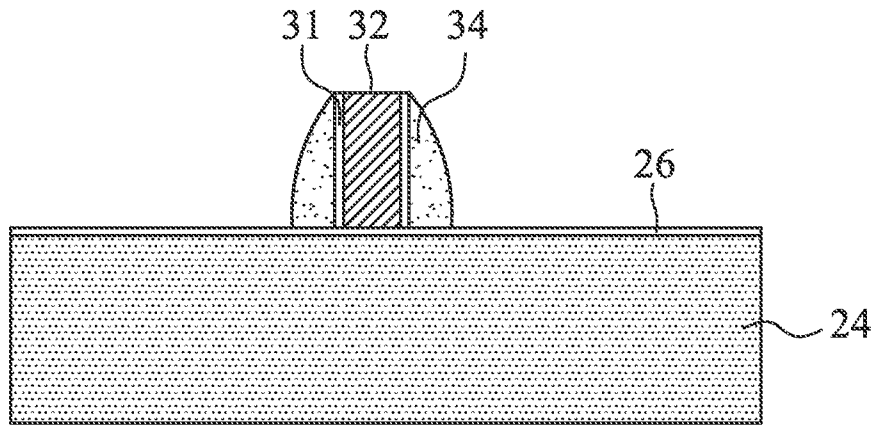

Fig. 2A

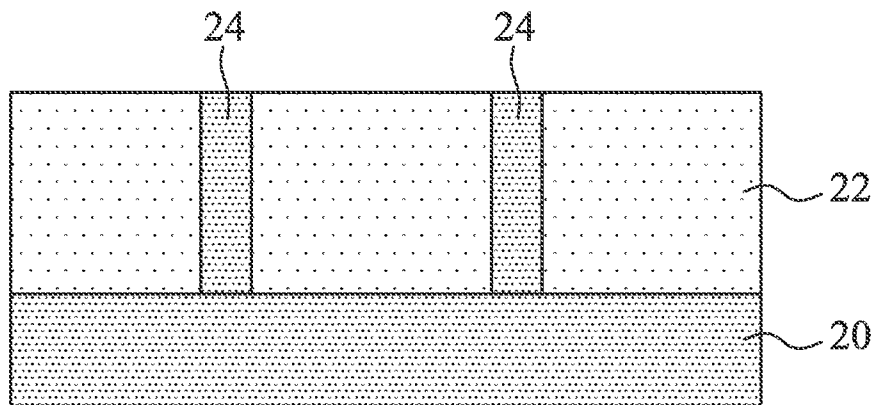

Fig. 2B

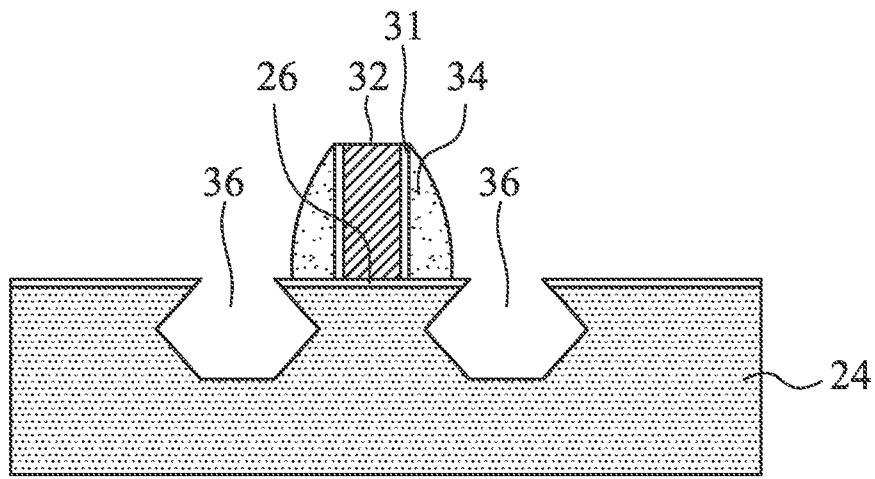

Fig. 3A

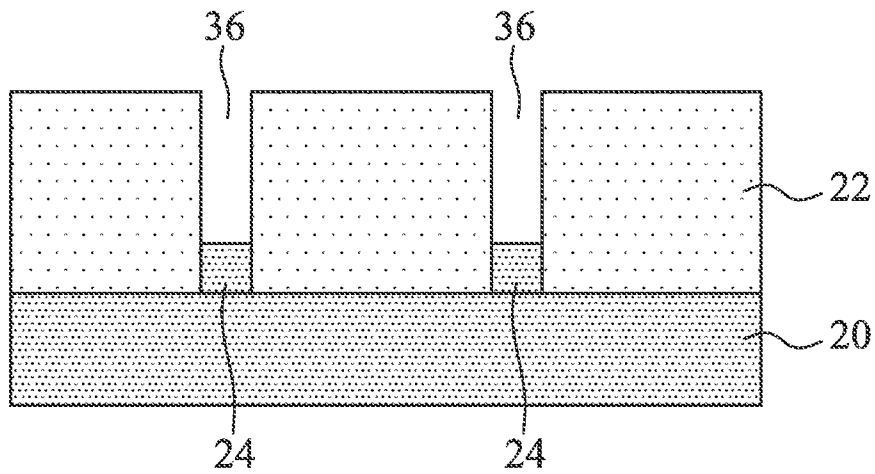

Fig. 3B

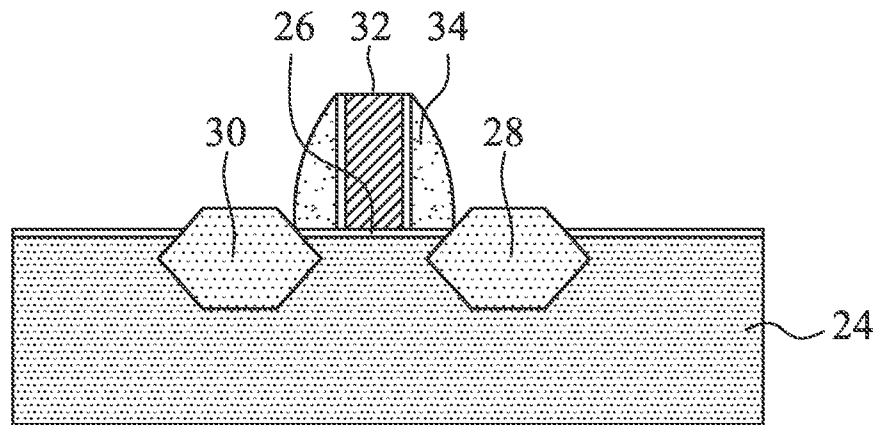

Fig. 4A

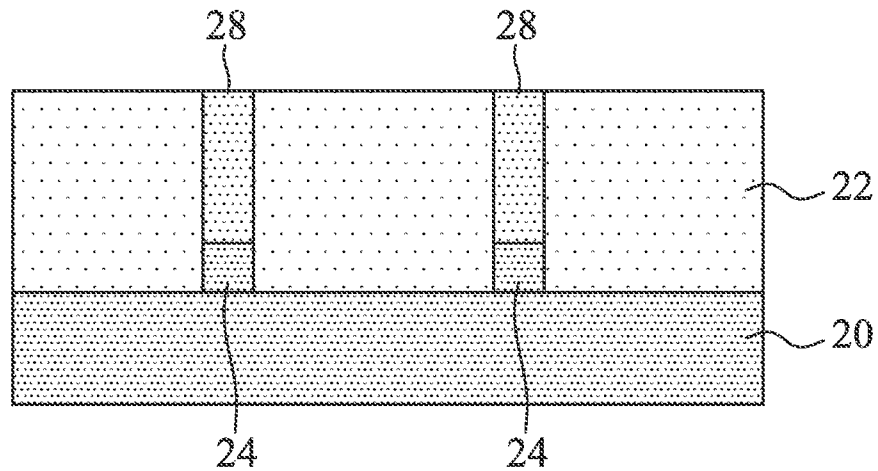

Fig. 4B

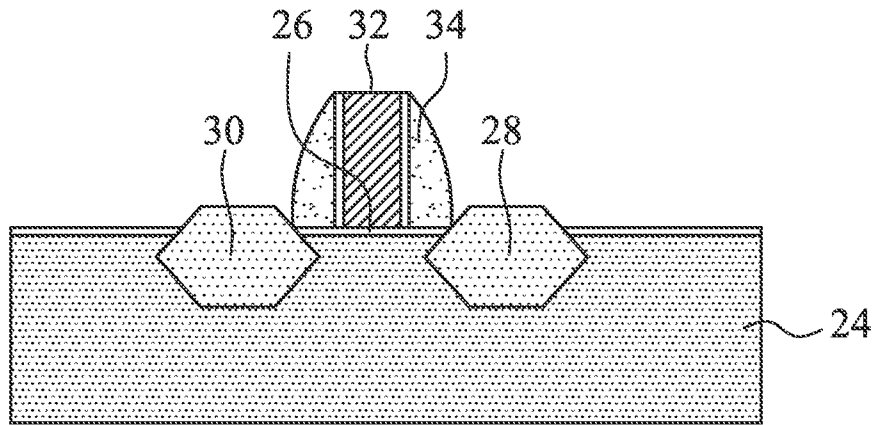

Fig. 5A

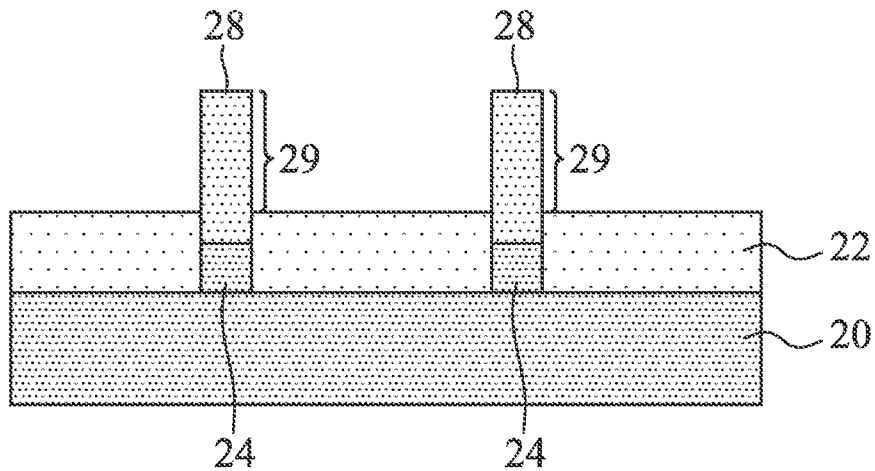

Fig. 5B

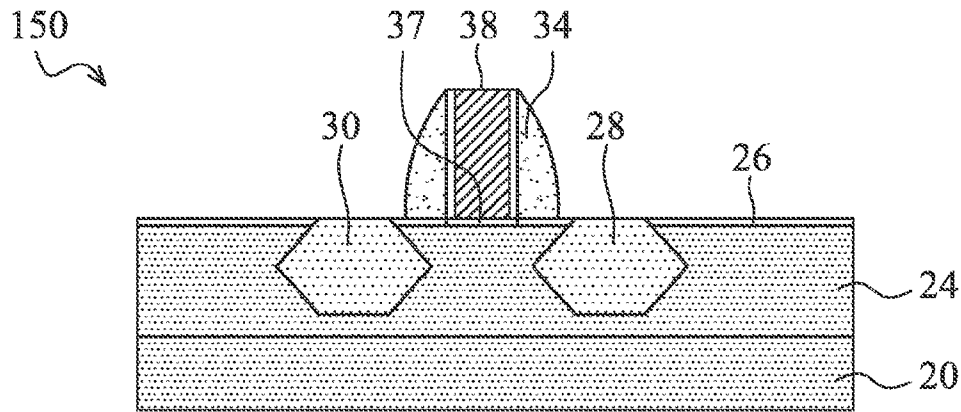

Fig. 6A

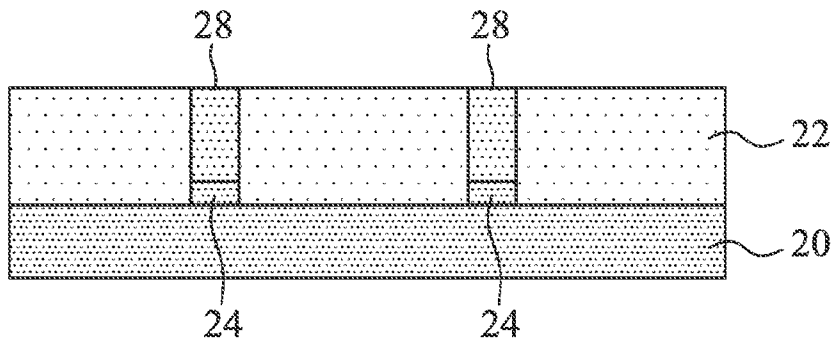

Fig. 6B

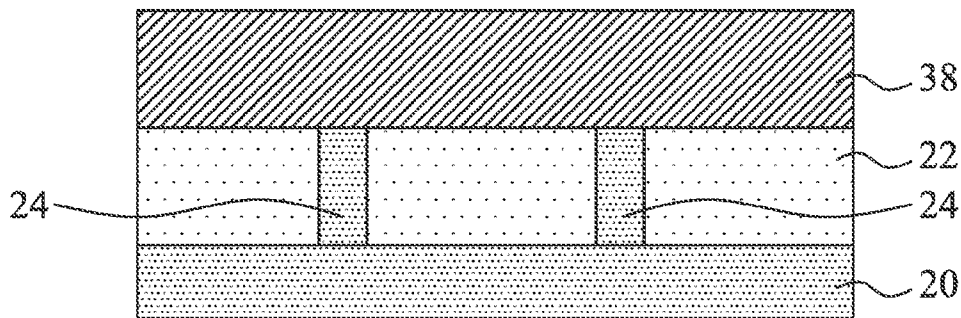

Fig. 6C

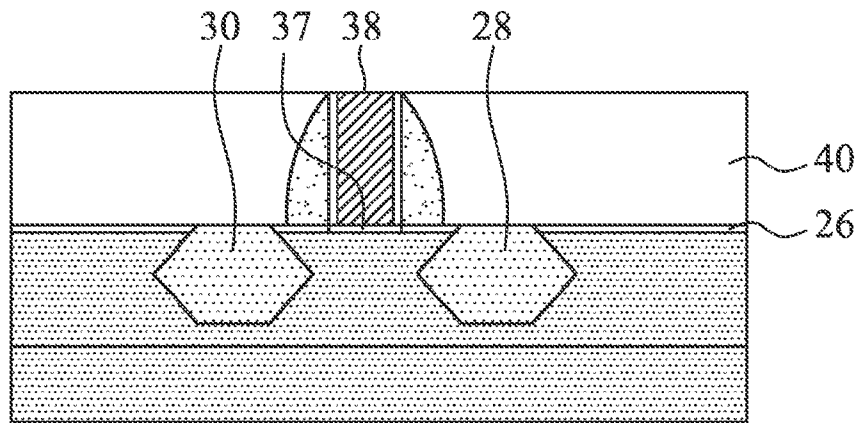

Fig. 7A

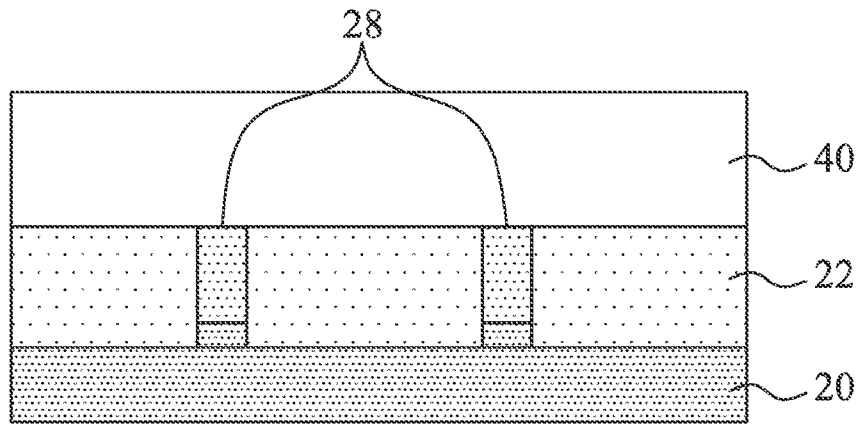

Fig. 7B

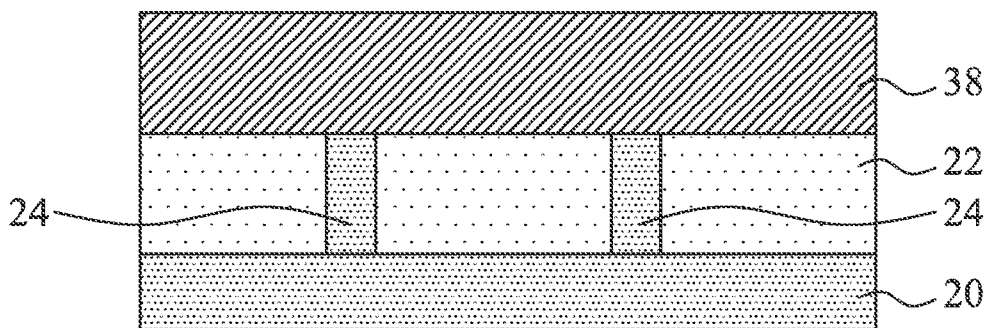

Fig. 7C

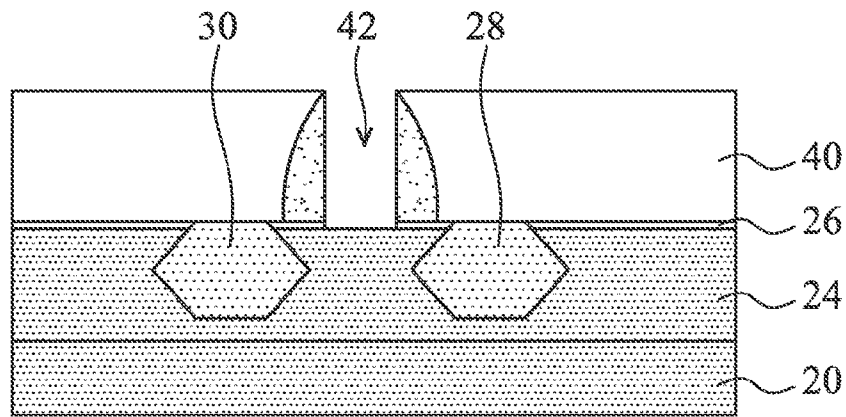

Fig. 8A

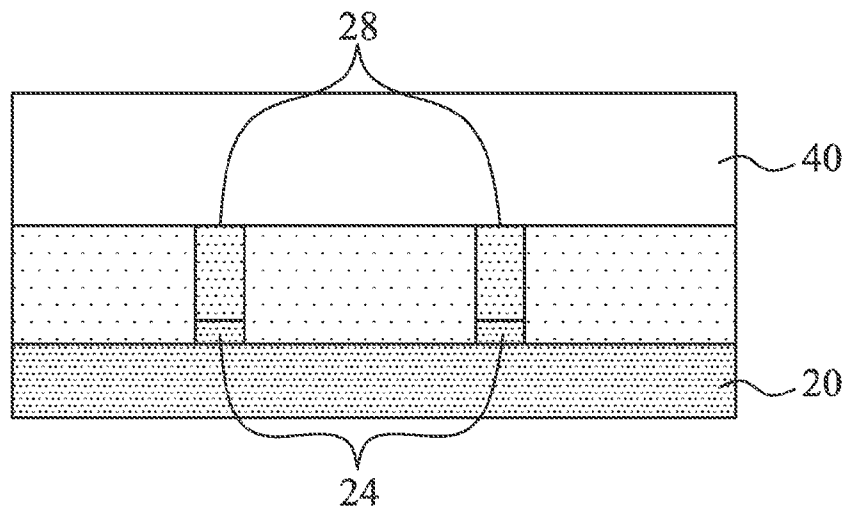

Fig. 8B

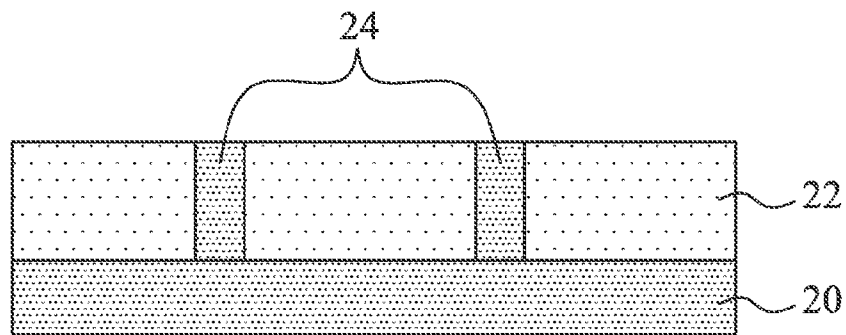

Fig. 8C

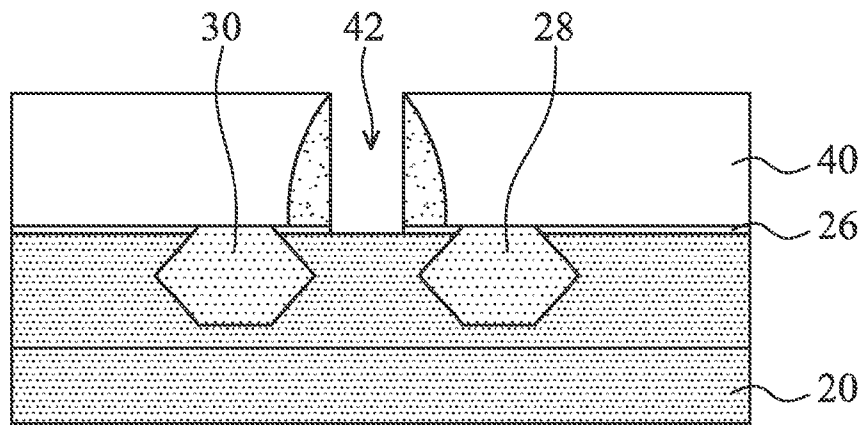

Fig. 9A

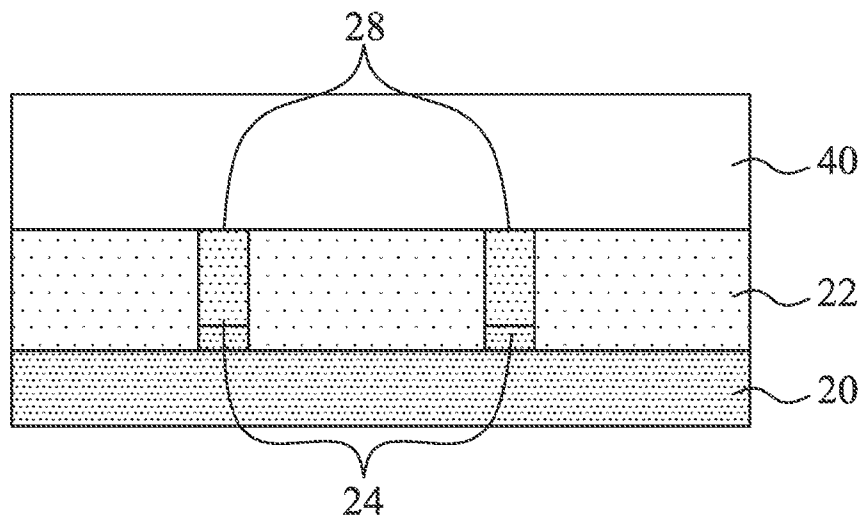

Fig. 9B

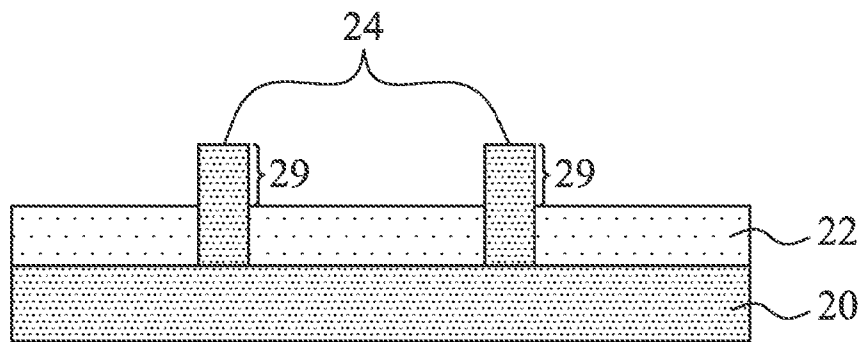

Fig. 9C

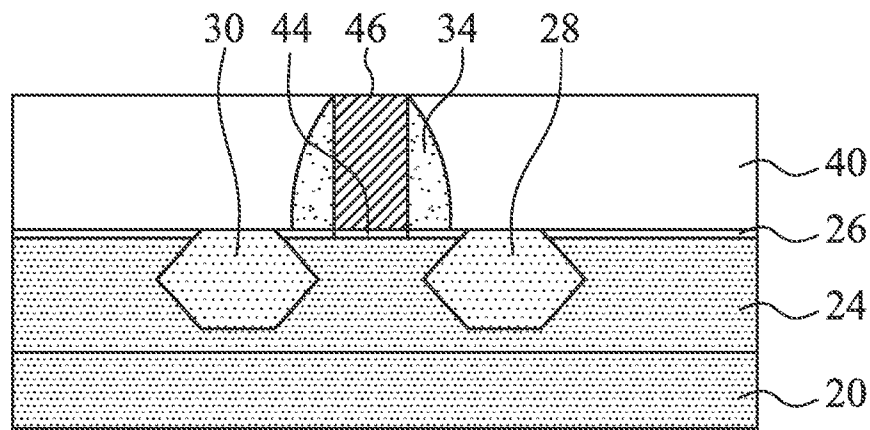

Fig. 10A

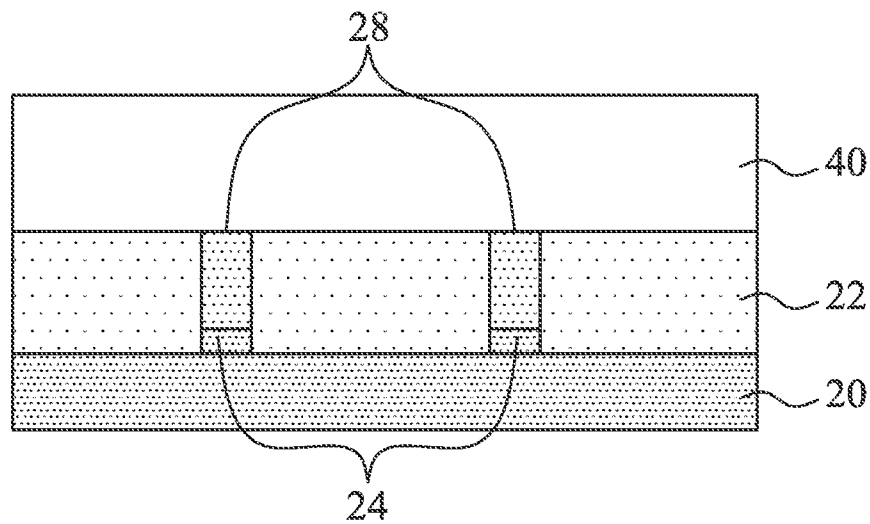

Fig. 10B

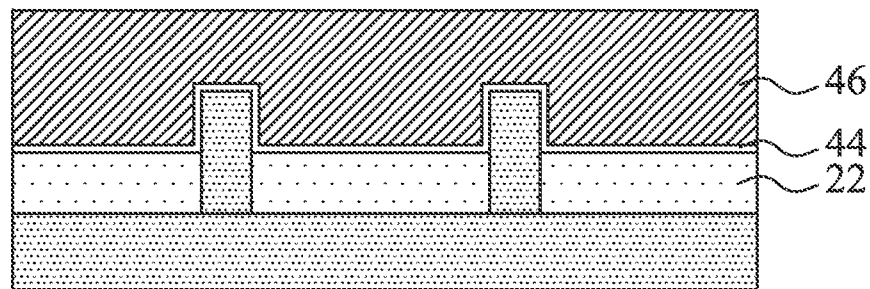

Fig. 10C

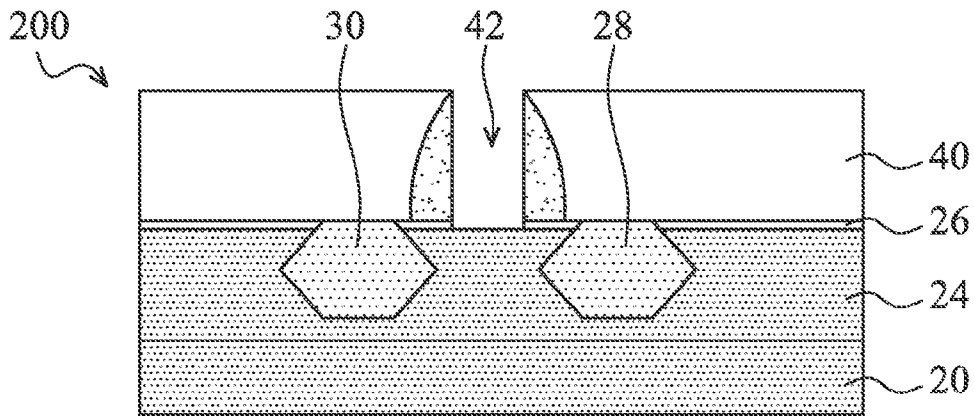

Fig. 11A

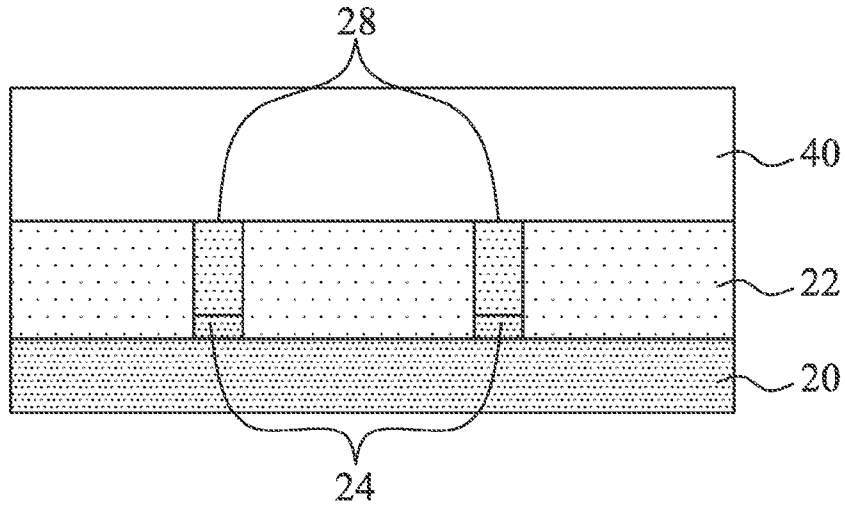

Fig. 11B

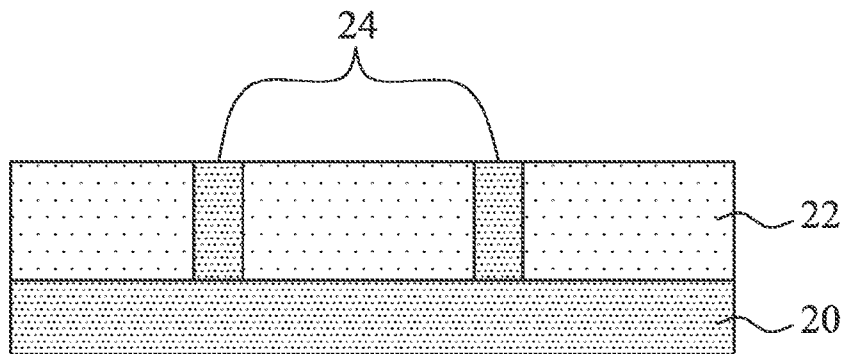

Fig. 11C

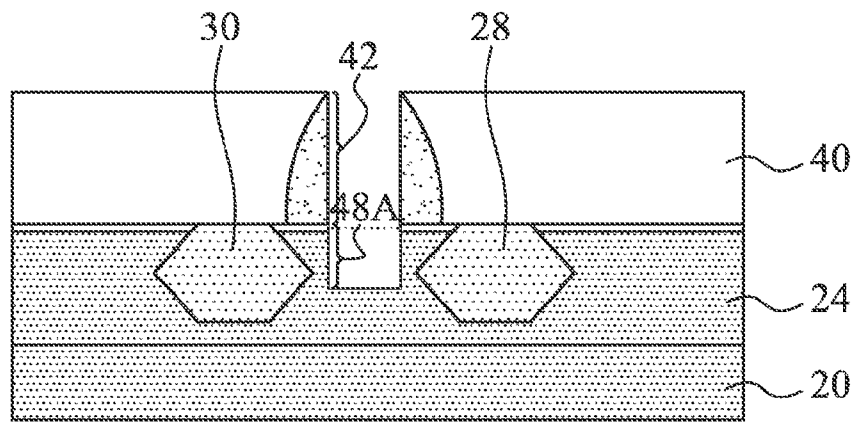

Fig. 12A

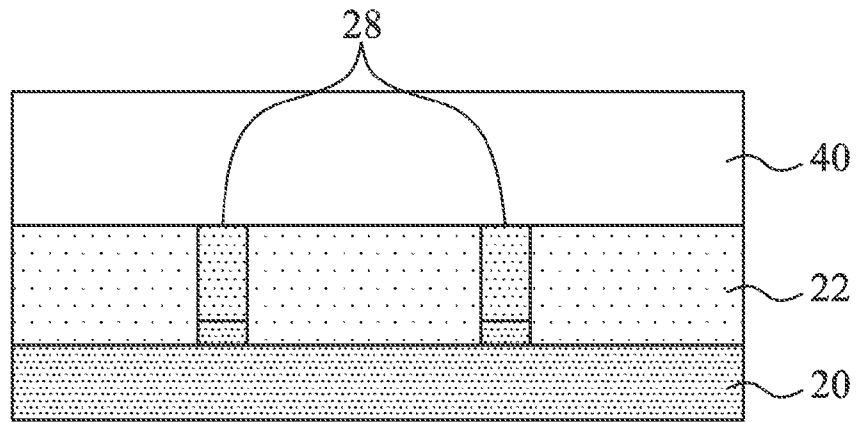

Fig. 12B

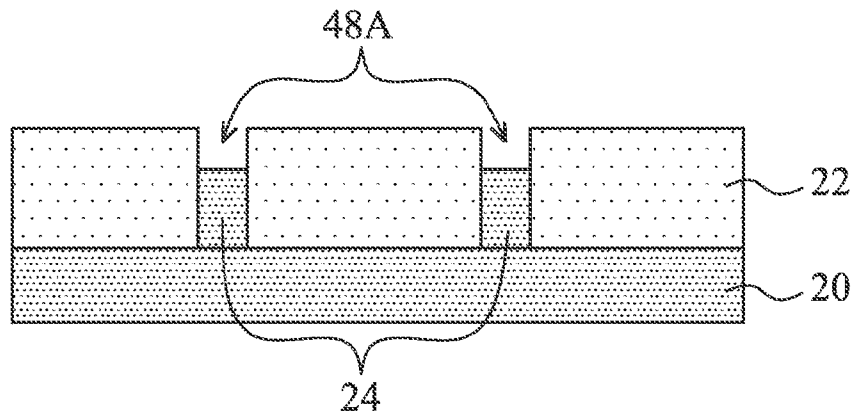

Fig. 12C

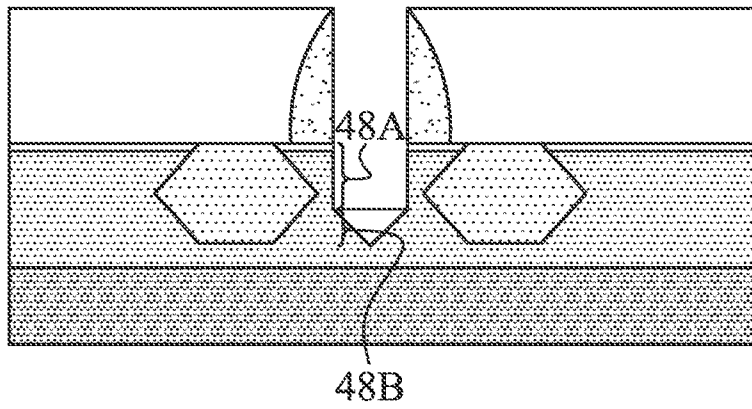

Fig. 13A

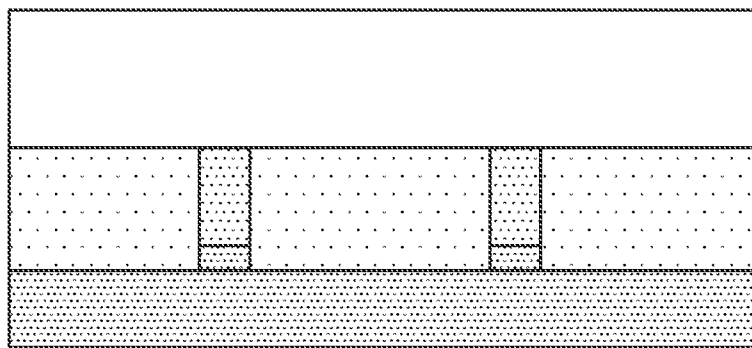

Fig. 13B

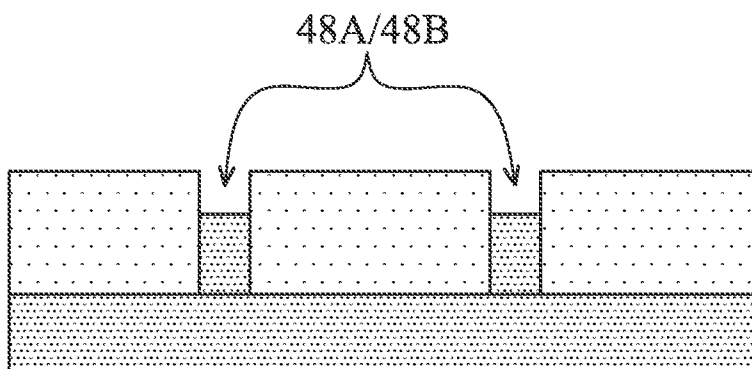

Fig. 13C

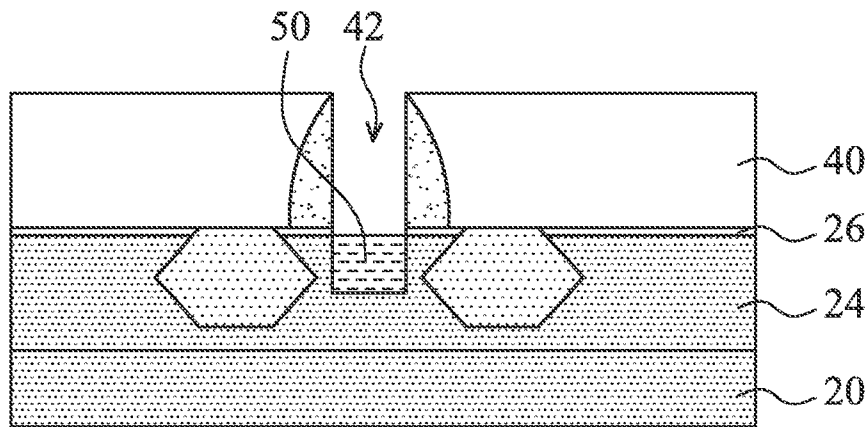

Fig. 14A

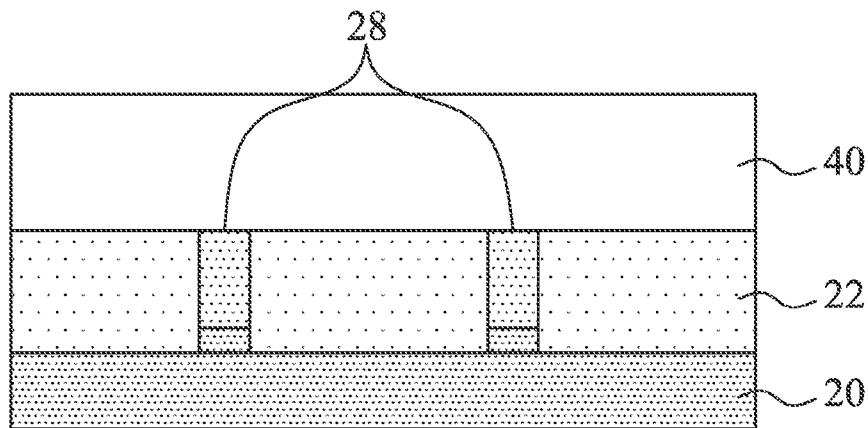

Fig. 14B

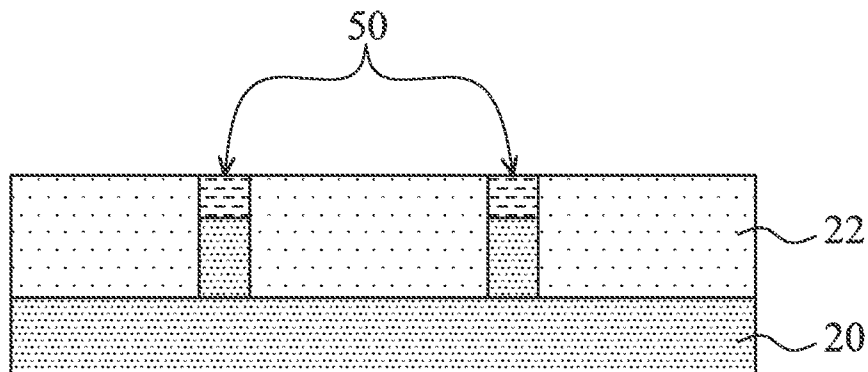

Fig. 14C

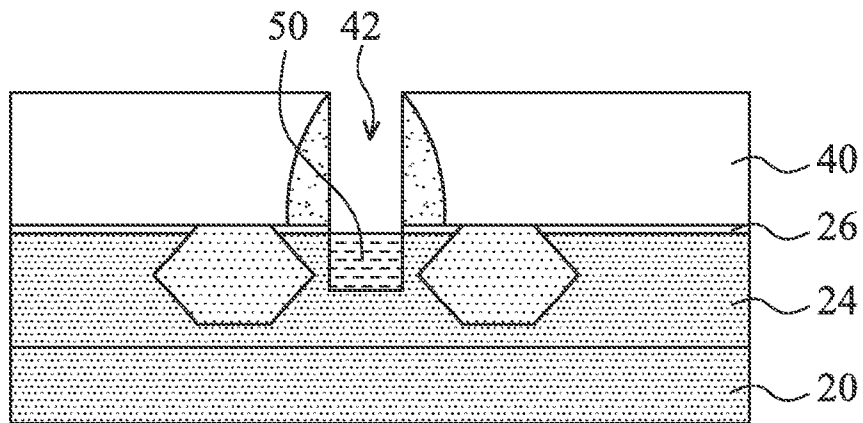

Fig. 15A

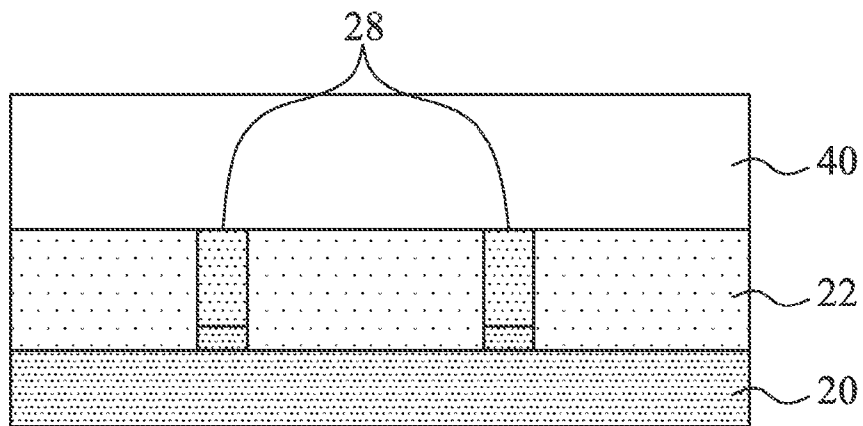

Fig. 15B

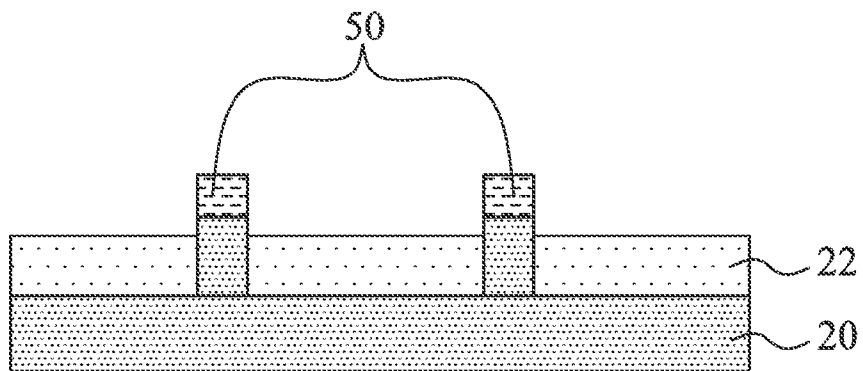

Fig. 15C

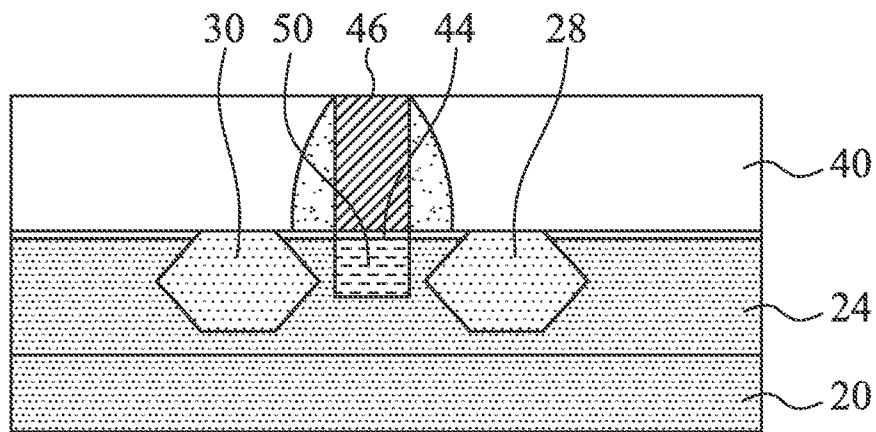

Fig. 16A

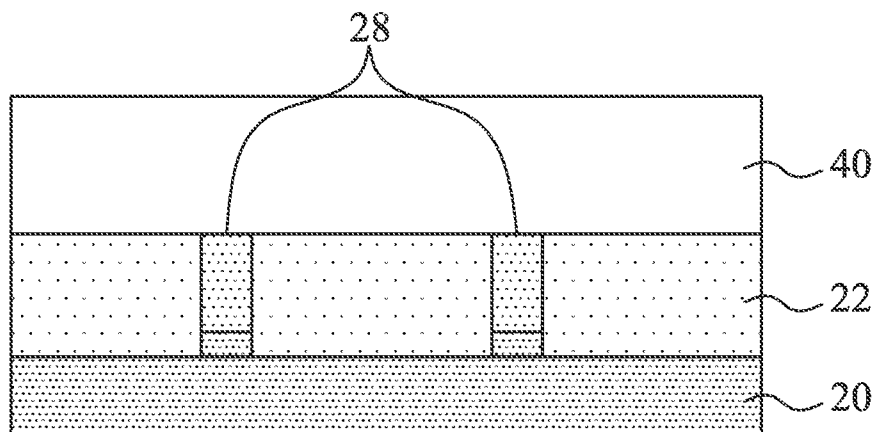

Fig. 16B

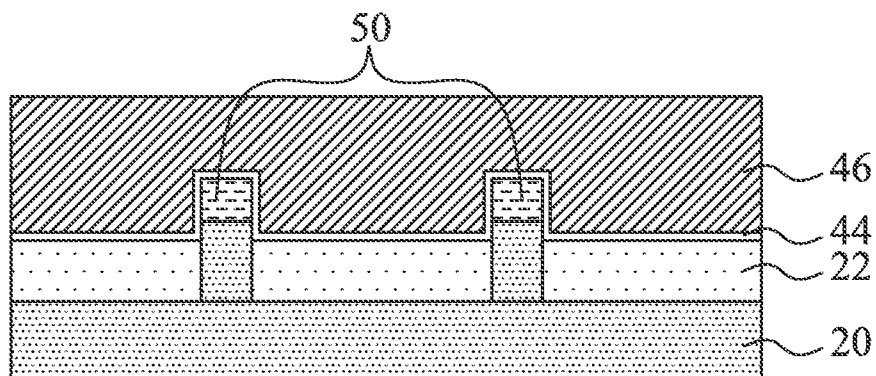

Fig. 16C

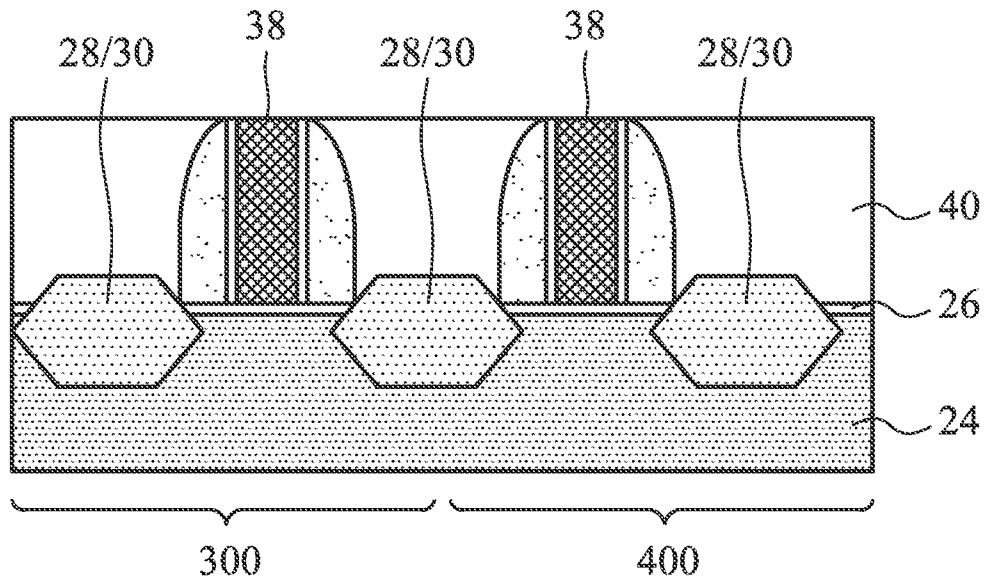

Fig. 17

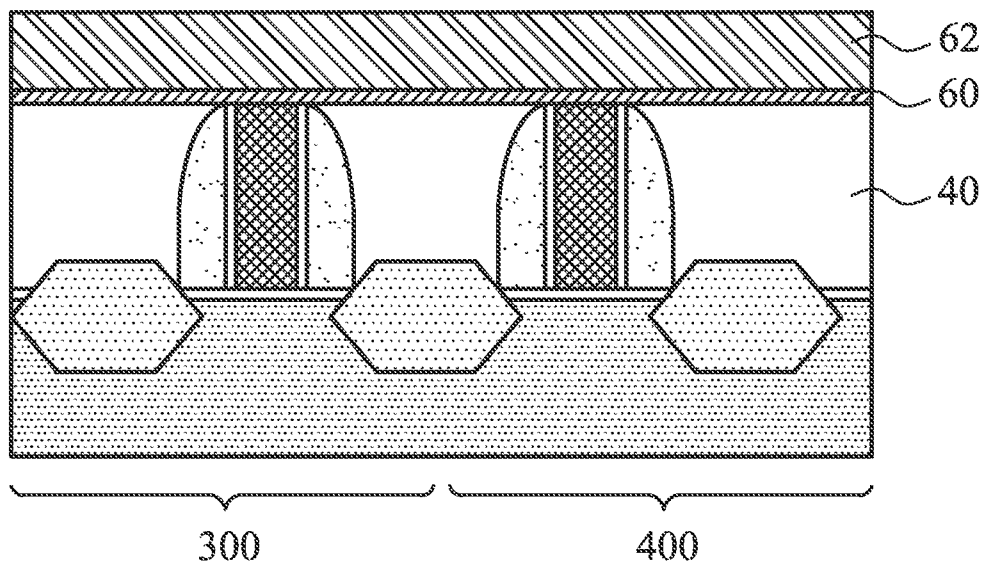

Fig. 18

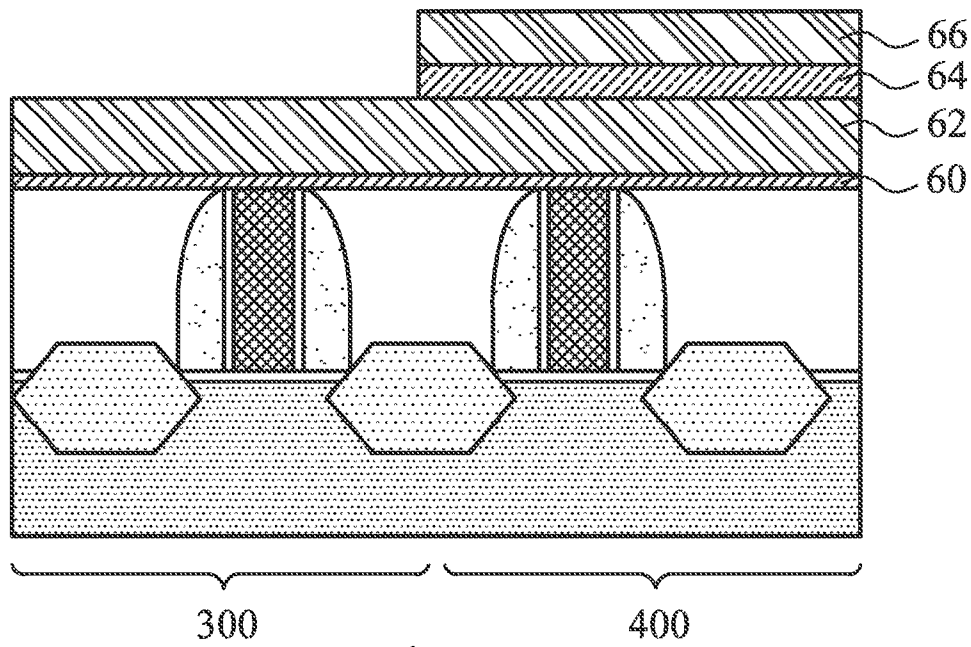

Fig. 19

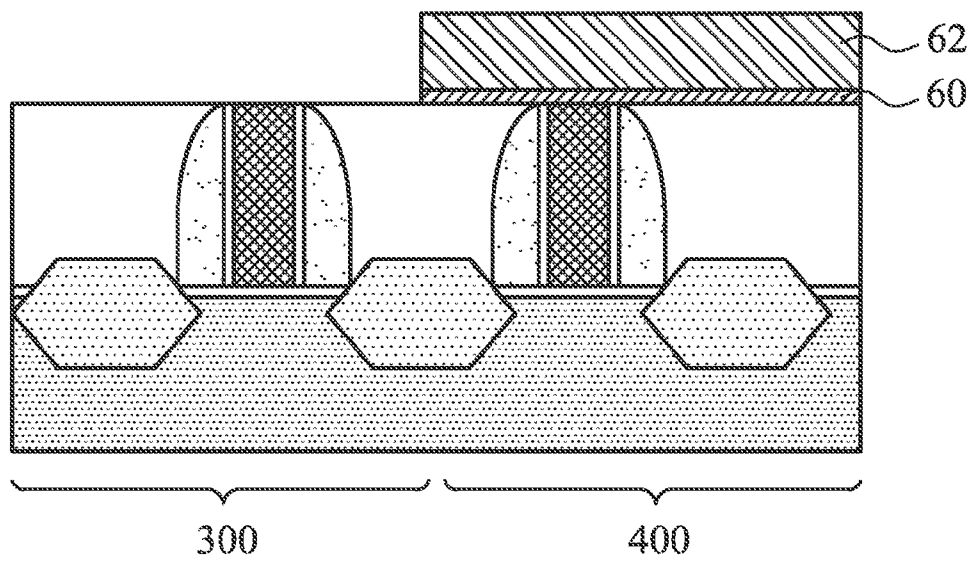

Fig. 20

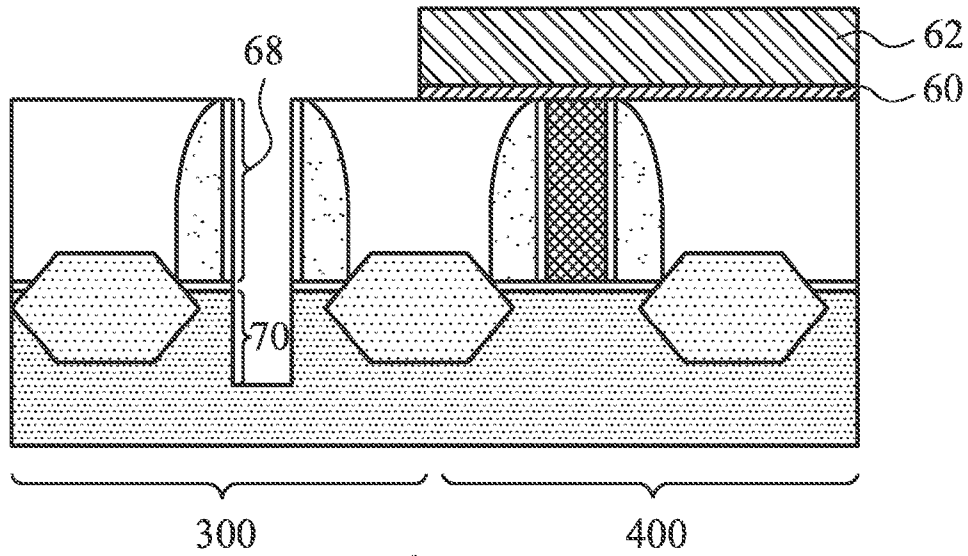

Fig. 21

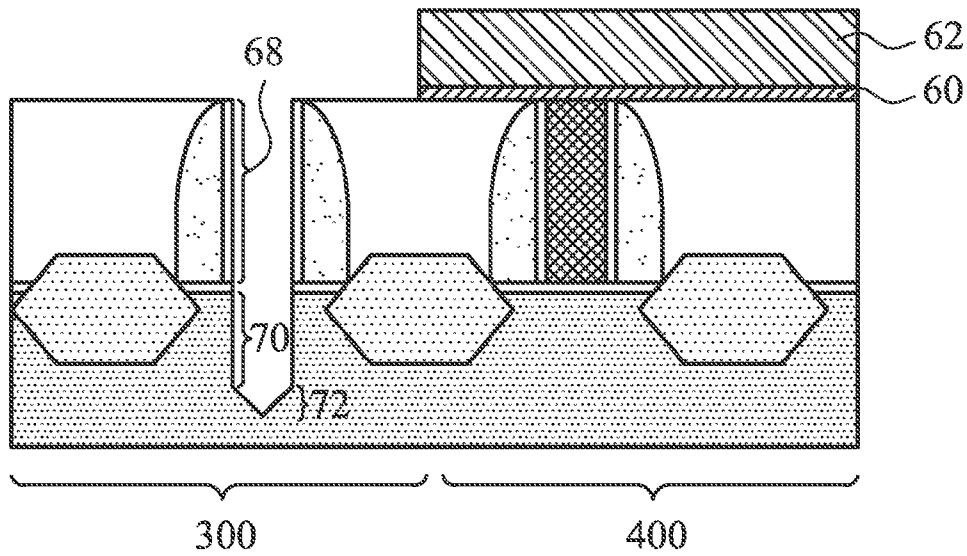

Fig. 22

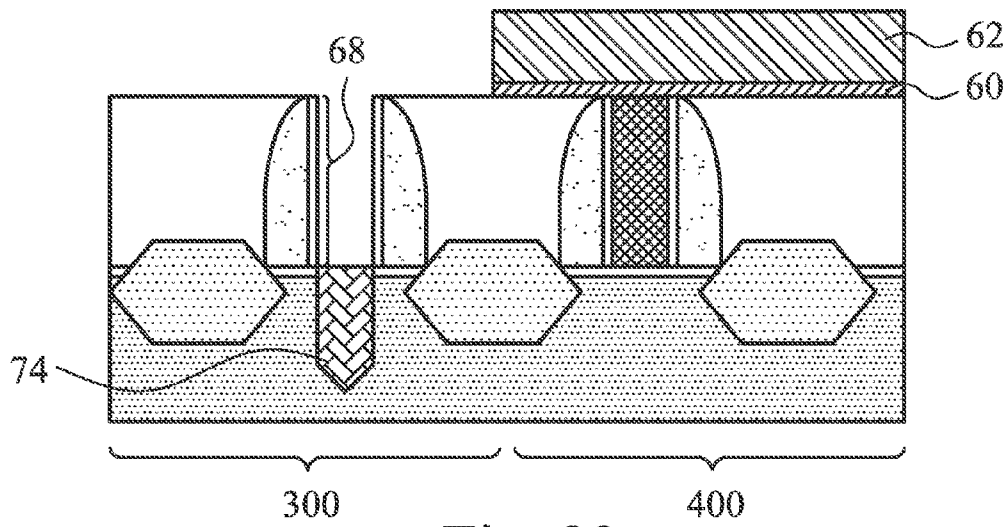

Fig. 23

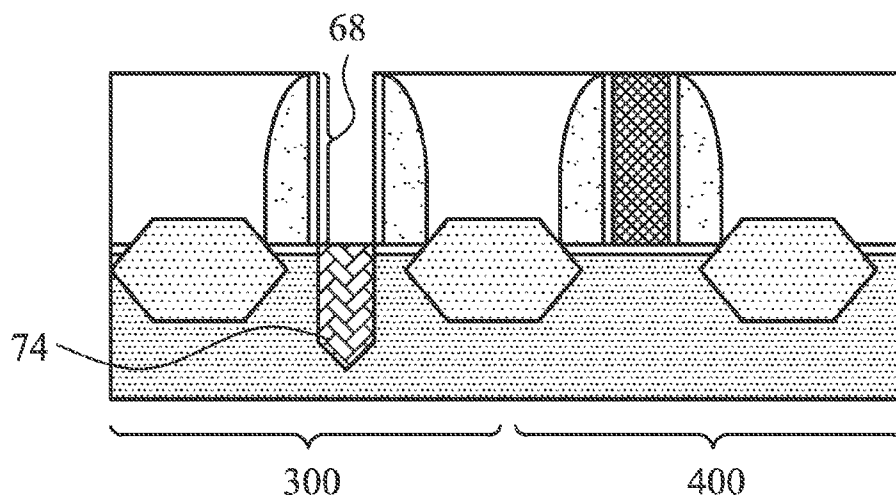

Fig. 24

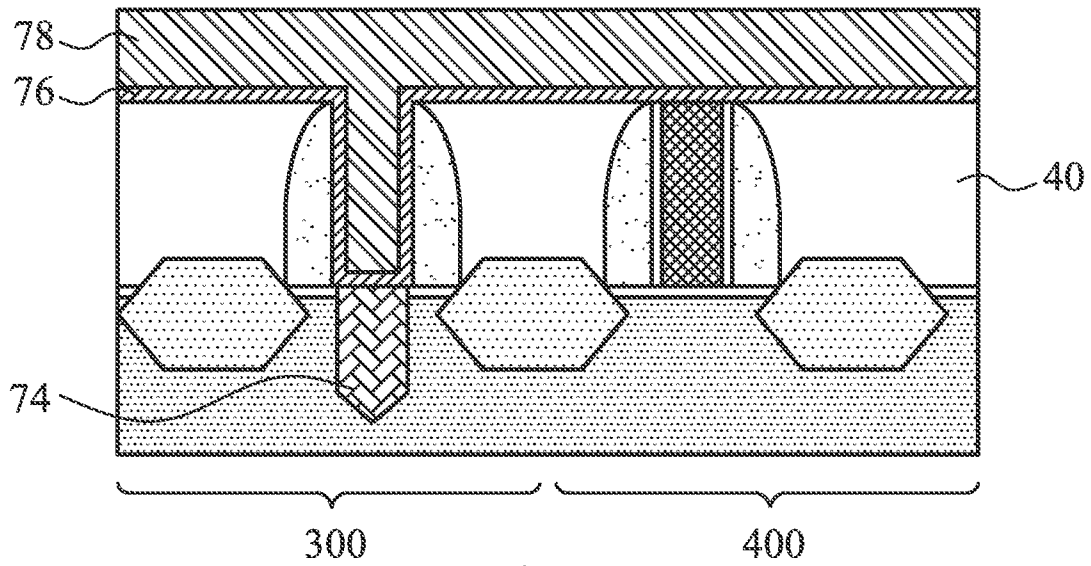

Fig. 25

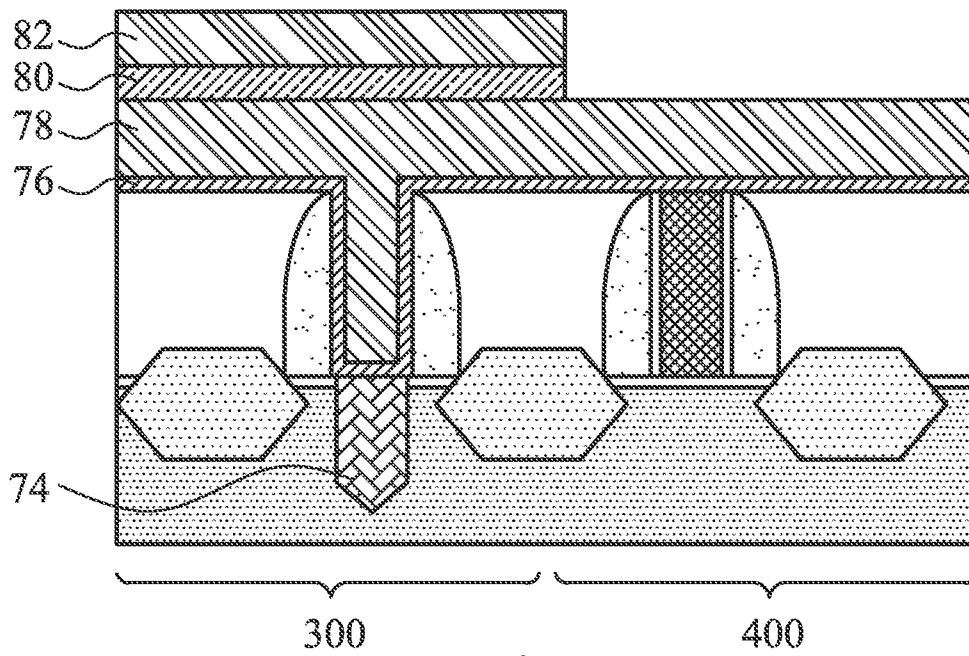

Fig. 26

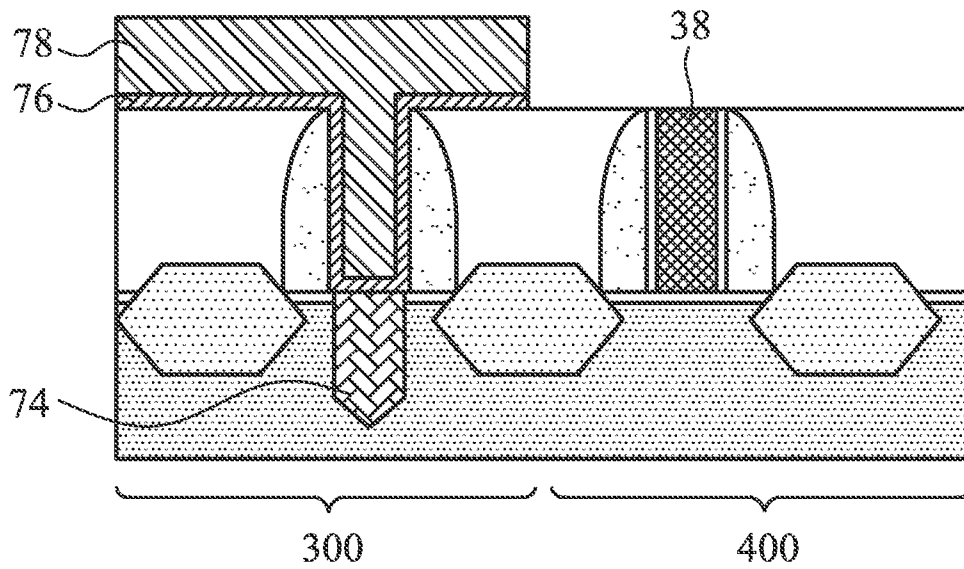

Fig. 27

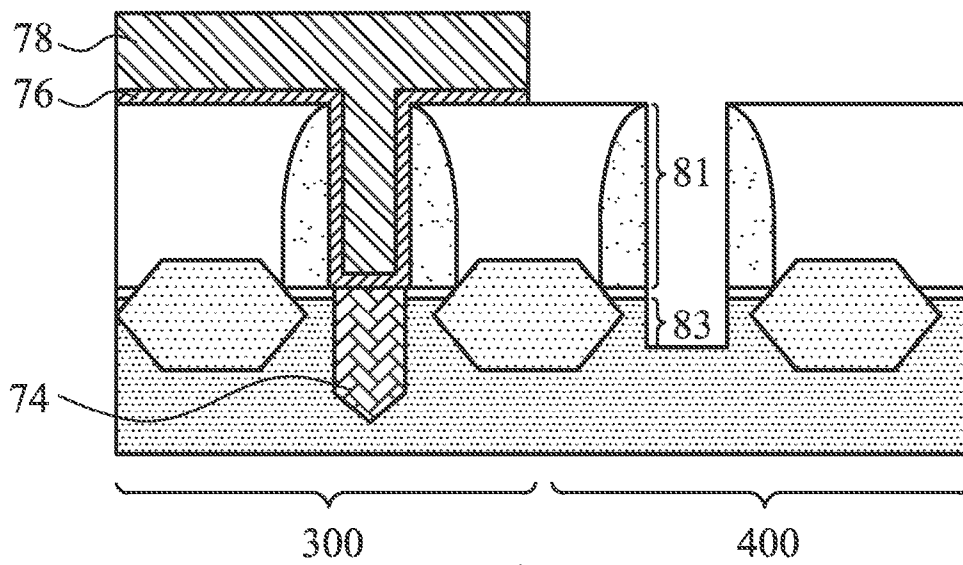

Fig. 28

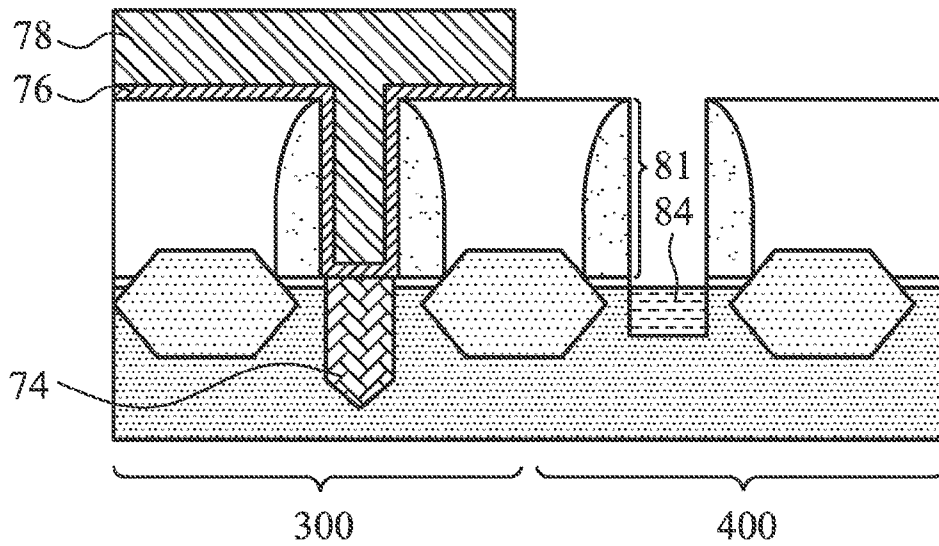

Fig. 29

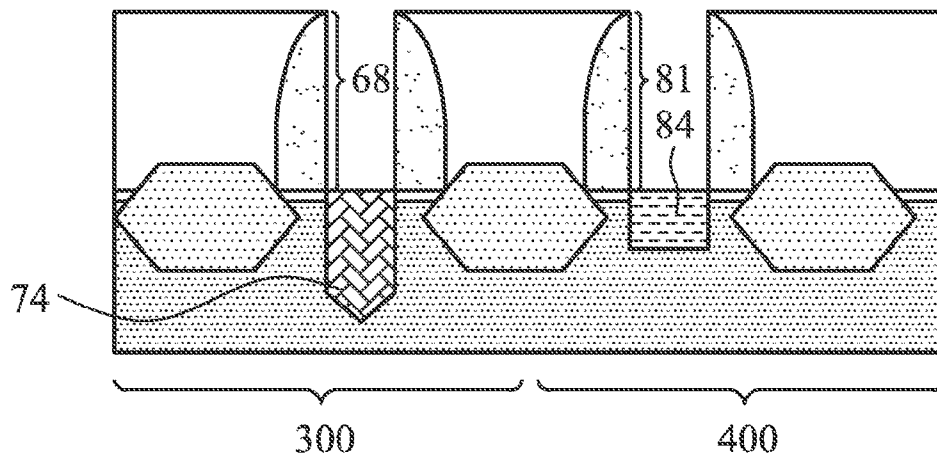

Fig. 30

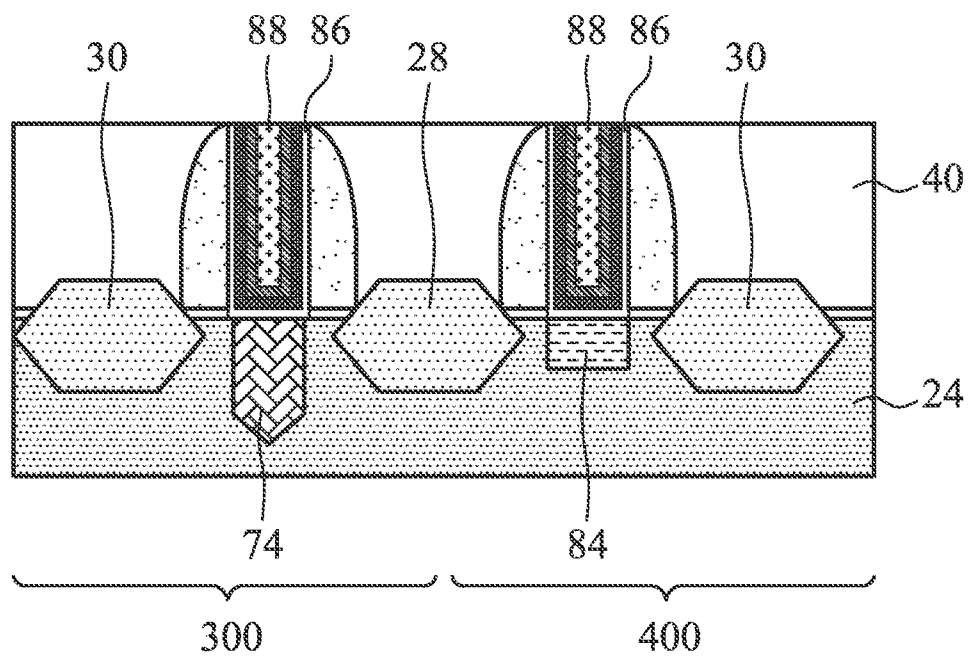

Fig. 31

1

FIN-LAST FINFET AND METHODS OF FORMING SAME

BACKGROUND

The cost and complexity associated with scaling of semiconductor device sizes according to Moore's law has given rise to new methods to improve semiconductor device characteristics. New gate materials such as high-k gate dielectrics and metal gates to decrease device leakage, FinFET devices with increased effective gate area as compared to same-size planar devices, and strain inducing channels for increased charge carrier mobility are a few examples of methods to continue Moore's Law scaling for next generation microprocessor designs.

BRIEF DESCRIPTION OF THE DRAWINGS

For a more complete understanding of the present embodiments, and the advantages thereof, reference is now made to the following descriptions taken in conjunction with the accompanying drawings, in which:

FIG. 1 illustrates a perspective view of a FinFET device according to an embodiment;

FIGS. 2A through 5B illustrate in cross-sectional views various stages in the manufacture of a Fin-Last FinFET device according to an embodiment;

FIGS. 6A through 10C illustrate in cross-sectional views various stages in the manufacture of a Fin-Last, Gate-Last FinFET device according to another embodiment;

FIGS. 11A through 16C illustrate in cross-sectional views various stages in the manufacture of a Fin-Last, Gate-Last, Replacement Channel FinFET device according to another embodiment; and

FIGS. 17 through 31 illustrate in cross-sectional views various stages in the manufacture of a PMOS and an NMOS Fin-Last, Gate-Last, Replacement Channel FinFET device according to another embodiment.

DETAILED DESCRIPTION OF ILLUSTRATIVE EMBODIMENTS

Reference will now be made in detail to embodiments illustrated in the accompanying drawings. Wherever possible, the same reference numbers are used in the drawings and the description to refer to the same or like parts. In the drawings, the shape and thickness may be exaggerated for clarity and convenience. This description will be directed in particular to elements forming part of, or cooperating more directly with, methods and apparatus in accordance with the present disclosure. It is to be understood that elements not specifically shown or described may take various forms well known to those skilled in the art. Many alternatives and modifications will be apparent to those skilled in the art, once informed by the present disclosure.

Reference throughout this specification to "one embodiment" or "an embodiment" means that a particular feature, structure, or characteristic described in connection with the embodiment is included in at least one embodiment. Thus, the appearances of the phrases "in one embodiment" or "in an embodiment" in various places throughout this specification are not necessarily all referring to the same embodiment. Furthermore, the particular features, structures, or characteristics may be combined in any suitable manner in one or more embodiments. It should be appreciated that the following figures are not drawn to scale; rather, these figures are merely intended for illustration.

2

Embodiments will be described with respect to a specific context, namely a FinFET device with a fin-last approach. Other embodiments may also be applied, however, to planar devices as well as fin devices.

FIG. 1 illustrates a perspective view of a FinFET device 100. The FinFET device 100 includes a plurality of semiconductor strips 24 on a semiconductor substrate 20 with a dielectric layer 22 on semiconductor substrate 20 and surrounding the semiconductor strips 24. Each semiconductor strip 24 may have a fin 29 that is above a top surface of the dielectric layer 22. Each fin 29 may have a drain region 28, a source region 30, and a channel region (not shown) disposed between the drain region 28 and the source region 30. A gate 32 may be disposed over the channel regions (not shown) of the fins 29. Although FIG. 1 illustrates a FinFET device 100 with four fins 29 and a single gate 32, other embodiments with less or more than four fins 29 and more than a single gate 32 are within the scope of this disclosure.

FIGS. 2A through 5B illustrate in cross-sectional views various stages in the manufacture of a Fin-Last FinFET device 100 according to an embodiment, with the Figures xA (e.g. 2A) being a cross-sectional view along the A-A line and the Figures xB (e.g. 2B) being a cross-sectional view along the B-B line.

The semiconductor substrate 20 may comprise bulk silicon, doped or undoped, or an active layer of a silicon-on-insulator (SOI) substrate. Generally, an SOI substrate comprises a layer of a semiconductor material such as silicon, germanium, silicon germanium, SOI, silicon germanium on insulator (SGOI), or combinations thereof. Other substrates that may be used include multi-layered substrates, gradient substrates, or hybrid orientation substrates.

The semiconductor substrate 20 may include active devices (not shown in FIG. 2B). As one of ordinary skill in the art will recognize, a wide variety of devices such as transistors, capacitors, resistors, combinations of these, and the like may be used to generate the structural and functional requirements of the design for the FinFET device 100. The devices may be formed using any suitable methods. The fins 29 may be electrically coupled to the active and passive devices. Only a portion of the semiconductor substrate 20 is illustrated in the figures, as this is sufficient to fully describe the illustrative embodiments.

In an embodiment, the semiconductor strips 24 may be formed by patterning the semiconductor substrate 20. The patterning process may be accomplished by depositing mask material (not shown) such as photoresist or silicon oxide over the semiconductor substrate 20. The mask material is then patterned and the semiconductor substrate 20 is etched in accordance with the pattern. The resulting structure includes a plurality of semiconductor strips 24 formed on the semiconductor substrate 20. Each of the plurality of semiconductor strips 24 has a sidewall being substantially orthogonal to a top surface of the semiconductor substrate 20. In some embodiments, the semiconductor substrate 20 is etched to a specific depth, meaning the semiconductor strips 24 are formed to a height, the semiconductor strips 24 may have a height from about 10 nm to about 500 nm. The semiconductor strips 24 may have a width from about 5 nm to 50 nm. The semiconductor strips 24 may have a length from about 0.01 um to 10 um. In an alternative embodiment, the semiconductor strips 24 may be epitaxially grown from a top surface of the semiconductor substrate 20 within trenches or openings formed in a patterned layer (e.g. the dielectric layer 22) atop the semiconductor substrate 20. Because the process is known in the art, the details are not repeated herein.

3

The semiconductor strips **24** may be formed of semiconductor material such as silicon, germanium, silicon germanium, or the like. In an embodiment, the semiconductor strips **24** are silicon. The semiconductor strips **24** may then be doped through an implantation process to introduce p-type or n-type impurities into the semiconductor strips **24**.

The dielectric layer **22** may be blanket deposited on the FinFET device **100**. The dielectric layer **22** may be made of one or more suitable dielectric materials such as silicon oxide, silicon nitride, low-k dielectrics such as carbon doped oxides, extremely low-k dielectrics such as porous carbon doped silicon dioxide, a polymer such as polyimide, combinations of these, or the like. The dielectric layer **22** may be deposited through a process such as chemical vapor deposition (CVD), or a spin-on-glass process, although any acceptable process may be utilized.

After the dielectric layer **22** is deposited, the dielectric layer **22** may be planarized to level a top surface of dielectric layer **22** and top surfaces of a hard mask layer (not shown in FIGS. **2A** and **2B**) on the tops of the semiconductor strips **24**. The hard mask layer may be removed by an etch process comprising H_3PO_4 or the like. The dielectric layer **22** may be planarized in a variety of ways. In an embodiment, the planarization process involves a chemical mechanical polishing (CMP), in which the dielectric layer **22** is reacted and then ground away using an abrasive. This process may continue until the tops of the semiconductor strips **24** are exposed. In another embodiment, the dielectric layer **22** may be thinned by a diluted hydrofluoric acid (DHF) treatment or a vapor hydrofluoric acid (VHF) treatment for a suitable time.

After the dielectric layer **22** is planarized, a gate **32** may be formed over the semiconductor strips **24** and the dielectric layer **22**. The gate **32** may include a gate dielectric layer **26** and gate spacers **34**. The gate dielectric layer **26** may be formed by thermal oxidation, CVD, sputtering, or any other methods known and used in the art for forming a gate dielectric. In other embodiments, the gate dielectric layer **26** includes dielectric materials having a high dielectric constant (k value), for example, greater than 3.9. The materials may include silicon nitrides, oxynitrides, metal oxides such as HfO_2 , $HfZrO_x$, $HfSiO_x$, $HfTiO_x$, $HfAlO_x$, the like, or combinations and multi-layers thereof.

The gate electrode layer (not shown) may be formed over the gate dielectric layer **26**. The gate electrode layer may comprise a conductive material and may be selected from a group comprising polycrystalline-silicon (poly-Si), polycrystalline silicon-germanium (poly-SiGe), metallic nitrides, metallic silicides, metallic oxides, and metals. The gate electrode layer may be deposited by CVD, sputter deposition, or other techniques known and used in the art for depositing conductive materials. The top surface of the gate electrode layer usually has a non-planar top surface, and may be planarized prior to patterning of the gate electrode layer or gate etch. Ions may or may not be introduced into the gate electrode layer at this point. Ions may be introduced, for example, by ion implantation techniques. The gate electrode layer and the gate dielectric layer may be patterned to form the gate **32**. The gate patterning process may be accomplished by depositing mask material (not shown) such as photoresist or silicon oxide over the gate electrode layer. The mask material is then patterned and the gate electrode layer is etched in accordance with the pattern.

Gate spacers **34** may be formed on opposite sides of the gate **32**. The gate spacers **34** are typically formed by blanket depositing a spacer layer (not shown) on the previously formed structure. In an embodiment, the gate spacers **34** may include a spacer liner **31**. The spacer liner **31** may comprise

4

SiN, SiC, SiGe, oxynitride, oxide, combinations thereof, or the like. The spacer layer may comprise SiN, oxynitride, SiC, SiON, oxide, combinations thereof, or the like and may be formed by methods utilized to form such a layer, such as CVD, plasma enhanced CVD (PECVD), low pressure CVD (LPCVD), atomic layer deposition (ALD), sputter, and other methods known in the art. The gate spacers **34** are then patterned, preferably by anisotropically etching to remove the spacer layer from the horizontal surfaces of the structure.

FIGS. **3A** and **3B** illustrate the etching of portions of the semiconductor strips **24** in a strained source drain (SSD) etch step to form recesses **36** in the semiconductor strips **24**. The SSD etch may selectively etch the semiconductor strips **24** without etching the dielectric layer **22** or the gate **32** and gate spacers **34**. In an embodiment, the recesses **36** may be etched to have a depth from about 5 nm to about 25 nm. The SSD etch step may be performed in a variety of ways. In an embodiment, the SSD etch step may be performed by a dry chemical etch with a plasma source and an etchant gas. The plasma source may be an inductively coupled plasma (ICP) etch, a transformer coupled plasma (TCP) etch, an electron cyclotron resonance (ECR) etch, a reactive ion etch (RIE), or the like and the etchant gas may be fluorine, chlorine, bromine, combinations thereof, or the like. In another embodiment, the SSD etch step may be performed by a wet chemical etch, such as ammonium peroxide mixture (APM), NH_4OH , TMAH, combinations thereof, or the like. In yet another embodiment, the SSD etch step may be performed by a combination of a dry chemical etch and a wet chemical etch.

After the recesses **36** are formed, the source regions **30** and drain regions **28** may be formed in the recesses **36** as illustrated in FIGS. **4A** and **4B**. The source regions **30** and the drain regions **28** may be formed by epitaxially growing SiGe, Si, SiP, combinations thereof, or the like in the recesses **36** with an optional cap layer of Si over the source regions **30** and the drain regions **28**. The epitaxial growth of the source regions **30** and the drain regions **28** forms a same crystalline orientation in the semiconductor strip **24**, the source regions **30**, and the drain regions **28**. The growth of the source regions **30** and the drain regions **28** may be substantially confined by the dielectric layer **22**. As illustrated in FIG. **4B**, sidewalls of the drain regions **28** may be substantially orthogonal to the top surface of the semiconductor substrate **20** and a top surface of the drain regions **28** may be substantially parallel with the top surface of the semiconductor substrate **20**. In an embodiment, the top surface of the drain regions **28** may be substantially coplanar with a top surface of the dielectric layer **22**. In another embodiment, the top surface of the drain regions **28** may be below or above the top surface of the dielectric layer **22**. Although FIG. **4B** only illustrates the drain regions **28**, the source regions **30** have a similar structural configuration on an opposite side of gate **32** such that the description of the drain regions **28** is applicable to the source regions **30** as well.

In a PMOS embodiment, the source regions **30** and the drain regions **28** may comprise SiGe_x (where $x \geq 0.1$) and may be doped with boron. In an NMOS embodiment, the source regions **30** and the drain regions **28** may comprise Si or SiP and may be doped with phosphorus. In both the NMOS and PMOS embodiments, the source regions **30** and the drain regions **28** may include a Si cap layer over the source regions **30** and the drain regions **28**.

FIGS. **5A** and **5B** illustrate the formation of fins **29**. The fins **29** may be formed by etching or recessing the dielectric layer **22** surrounding the semiconductor strips **24**. The portion of the semiconductor strips **24** that extend above a top surface of the dielectric layer **22** forms the fins **29**. In an embodiment, a top surface of the fin **29** may extend above the top surface of

5

the dielectric layer **22** by about 10 nm to about 30 nm. The fins **29** may be formed by a chemical oxide reaction such as a CERTAS® etch, a Siconi etch (also referred to as SiCoNi), a DHF treatment, combinations thereof, or the like.

By forming the fins **29** after the source regions **30** and the drain regions **28** have been formed, the shape of source regions **30** and the drain regions **28** may be controlled and confined by the dielectric layer **22**. This control and confinement will reduce or eliminate the faceting of the source regions **30** and the drain regions **28** which will reduce the resistance of the subsequent metal layers contacting the source regions **30** and the drain regions **28**. Also, the facets on the source regions **30** and the drain regions **28** may allow the subsequent metal layers to leak through the intersection of the facets.

FIGS. **6A** through **10C** illustrate in cross-sectional views various stages in the manufacture of a Fin-Last, Gate-Last FinFET device **150** according to another embodiment, with the Figures xA (e.g. **6A**) being a cross-sectional view along the A-A line of FIG. **1**, the Figures xB (e.g. **6B**) being a cross-sectional view along the B-B line of FIG. **1**, and the Figure xC (e.g. **6C**) being a cross-sectional view along the C-C line of FIG. **1**. Details regarding this embodiment that are similar to those for the previously described embodiment will not be repeated herein.

The FinFET device **150** in FIGS. **6A** through **6C** is at a similar stage of processing as the FinFET device **100** in FIGS. **4A** and **4B** except for the FinFET device **150** has a dummy gate **38** and a dummy gate dielectric layer **37** beneath the dummy gate **38**. As such, the processing steps up to this stage are similar to those described in FIGS. **2A** through **3B**, and are not repeated herein. The dummy gate dielectric layer **26** may comprise similar materials as described in reference to FIGS. **2A** and **2B**, although any material suitable as a dummy gate dielectric may be used. In an embodiment, the dummy gate **38** may be formed from similar materials as gate **32** or dummy gate **38** may comprise a layer of TiN, TaN, combinations thereof, or the like on the dummy gate dielectric layer **37** followed by a layer of polysilicon.

FIGS. **7A** through **7C** illustrate the formation of an etch stop layer (ESL) (not shown) and an inter-layer dielectric (ILD) **40** formed over the semiconductor substrate **20**, the dummy gate **38**, spacer liners **31**, gate spacers **34**, source region **30**, and drain region **28**. The ESL may be conformally deposited over components on the semiconductor substrate **20**. In an embodiment, the ESL is silicon nitride, silicon oxide, the like, or a combination thereof and may be formed by PECVD, LPCVD, ALD, the like, or a combination thereof.

The ILD **40** may be formed over the ESL. In an embodiment, the ILD **40** may comprise silicon oxide, silicon nitride, the like, or a combination thereof. The ILD **40** may be formed by CVD, a high density plasma (HDP), the like, or a combination thereof. The ILD **40** may be planarized to a top surface of the dummy gate **38**. In an embodiment, the ILD **40** is planarized by using a CMP to remove portions of the ILD **40**. In other embodiments, other planarization techniques may be used, such as etching.

FIGS. **8A** through **8C** illustrate the removal of dummy gate **38** and the dummy gate dielectric layer **37** forming an opening **42** over the channel region in the semiconductor strip **24** between the source region **30** and the drain region **28**. The dummy gate **38** may be removed by a dry etch that is selective to the material of the dummy gate **38**. For example, if the dummy gate **38** comprises polysilicon, a dry etch using NF₃, SF₆, Cl₂, HBr, the like, or a combination thereof or a wet etch

6

using NH₄OH, tetramethylammonium hydroxide (TMAH), the like, or a combination thereof may be used to remove the dummy gate **38**.

After the dummy gate **38** is removed, the fins **29** may be formed by an etch process to recess the dielectric layer **22** in the area under the removed dummy gate **38** (see FIG. **9C**). This fin formation step may be performed by similar processes as described in the fin formation of FIGS. **5A** and **5B**, and is not repeated herein. In an embodiment, the dielectric layer **22** may be recessed beneath the opening **42** (see FIG. **9C**), but not in the areas surrounding the source region **30** and the drain region **28** (see FIG. **9B**).

FIGS. **10A** through **10C** illustrate the formation of gate dielectric layer **44** and gate **46** in the opening **42**. The gate dielectric layer **44** and gate **46** may be formed of similar materials and by similar processes as gate dielectric layer **26** and gate **32** described in FIGS. **2A** and **2B**, and are not repeated herein. As shown in FIG. **10C**, the gate **46** and the gate dielectric layer **44** adjoins three sides of the fin **29**.

FIGS. **11A** through **16C** illustrate in cross-sectional views various stages in the manufacture of a Fin-Last, Gate-Last, Replacement Channel FinFET device **200** according to another embodiment, with the Figures xA (e.g. **6A**) being a cross-sectional view along the A-A line of FIG. **1**, the Figures xB (e.g. **6B**) being a cross-sectional view along the B-B line of FIG. **1**, and the Figure xC (e.g. **6C**) being a cross-sectional view along the C-C line of FIG. **1**. Details regarding this embodiment that are similar to those for the previously described embodiments will not be repeated herein.

The FinFET device **200** in FIGS. **11A** through **11C** is at a similar stage of processing as the FinFET device **150** in FIGS. **9A** through **9C** with the dummy gate and dummy gate dielectric removed to form opening **42**. As such, the processing steps up to this stage are similar to those described in FIGS. **2A** through **3B** and **6A** through **9C** are not repeated herein.

FIGS. **12A** through **12C** illustrate the removal of the channel region by forming an opening **48A** in the semiconductor strips **24**. The opening **48A** may be formed to a depth of about 5 nm to about 45 nm from a top surface of the semiconductor strip **24**. The opening **48A** may be formed by an etch process. In an embodiment, the etch may be performed by a dry chemical etch with a plasma source and an etchant gas. The plasma source may be an ICR, a TCP, an ECR, a RIE, or the like and the etchant gas may be fluorine, chlorine, bromine, combinations thereof, or the like.

FIGS. **13A** through **13C** illustrate an embodiment wherein another etch is performed to form opening **48B** to have a V-shape below the opening **48A**. A V-shape opening may be accomplished by the embodiment that comprises a wet chemical etch such as NH₄OH, TMAH, the like, or a combination thereof. The step of forming opening **48B** is optional as the final shape of the replacement channel opening could be non-V shape (opening **48A** only) or V-shape (opening **48A** in addition to **48B**).

After the opening **48A** and the optional opening **48B** are formed, the replacement channel **50** may be formed in the opening **48A** as illustrated in FIGS. **14A** through **14C**. The replacement channel region **50** may induce a strain and/or allow higher mobility in the channel region so that the FinFET device **200** may have better device performance. The replacement channel region **50** may be formed by epitaxially growing SiGe, Si, SiP, Ge, the like, or a combination thereof in the **48A** with an optional cap layer of Si over the replacement channel region **50**. The growth of the replacement channel region **50** may be substantially confined by the dielectric layer **22** and the semiconductor strip **24**. As illustrated in FIGS. **14A** and **14C**, sidewalls of the replacement channel

region 50 may be substantially orthogonal to the top surface of the semiconductor substrate 20 and a top surface of the replacement channel region 50 may be substantially parallel with the top surface of the semiconductor substrate 20. In an embodiment, the top surface of the replacement channel region 50 may be substantially coplanar with a top surface of the dielectric layer 22 and the top surface of the semiconductor strip 24. In another embodiment, the top surface of the replacement channel region 50 may be below or above the top surface of the dielectric layer 22 and the semiconductor strip 24.

In a PMOS embodiment, the replacement channel region 50 may comprise SiGex (where $x > 0.1$) and may be doped with boron. In an NMOS embodiment, the replacement channel region 50 may comprise Si and may be doped with phosphorous. In both the NMOS and PMOS embodiments, the replacement channel 50 may include a Si cap layer over the replacement channel region 50.

After the replacement channel region 50 is formed, the fins 29 may be formed by an etch process to recess the dielectric layer 22 in the area under the opening 42 as illustrated in FIGS. 15A through 15C. This fin formation step may be performed by similar processes as described in the fin formation of FIGS. 5A and 5B, and is not repeated herein. In an embodiment, the dielectric layer 22 may be recessed beneath the opening 42 (see FIG. 15C), but not in the areas surrounding the source region 30 and the drain region 28 (see FIG. 15B).

FIGS. 16A through 16C illustrate the formation of gate dielectric layer 44 and gate 46 in the opening 42 and over the replacement channel region 50. The gate dielectric layer 44 and gate 46 may be formed of similar materials and by similar processes as gate dielectric layer 26 and gate 32 described in FIGS. 2A and 2B, and are not repeated herein. As shown in FIG. 16C, the gate 46 and the gate dielectric layer 44 adjoins three sides of the fin 29.

By forming the fins 29 after the source regions 30 and the drain regions 28 have been formed, the shape of source regions 30 and the drain regions 28 may be controlled and confined by the dielectric layer 22. This control and confinement will reduce or eliminate the faceting of the source regions 30 and the drain regions 28 which will reduce the resistance of the subsequent metal layers contacting the source regions 30 and the drain regions 28. Also, the facets on the source regions 30 and the drain regions 28 may allow the subsequent metal layers to leak through the intersection of the facets. Further, by replacing the channel region with a replacement channel region 50, the FinFET device 200 may have better performance due to the strain inducing and/or high mobility channel region.

FIGS. 17 through 31 illustrate in cross-sectional views along a semiconductor strip 24 (A-A line of FIG. 1) of various stages in the manufacture of a PMOS FinFET 400 and an NMOS FinFET 300, both in a Fin-Last, Gate-Last, Replacement Channel configuration according to another embodiment. Details regarding this embodiment that are similar to those for the previously described embodiments will not be repeated herein.

FIG. 17 illustrates an NMOS FinFET 300 and a PMOS FinFET 400 with each of the NMOS and PMOS FinFETs 300 and 400 comprising a source region 30 and a drain region 28. The source regions 30 and the drain region 28 are formed in a semiconductor strip 24 with an ILD 40 formed over the semiconductor strip 24 and the dummy gates 38.

FIG. 18 illustrates an ESL 60 formed over the ILD 40 and the dummy gates 38 and a hard mask layer 62 formed over the ESL 60. The ESL 60 may be formed of an oxide, a nitride, the

like, or a combination thereof and the hard mask layer 62 may be formed of SiN, SiON, SiO₂ the like, or a combination thereof.

In FIG. 19, a bottom anti-reflective coating (BARC) layer 64 is formed over the hard mask layer 62. The BARC layer 64 prevents radiation in a subsequent photolithographic process to reflect off layers below and interfering with the exposure process. Such interference can increase the critical dimension of the photolithography process. The BARC layer 64 may be formed by CVD, the like, or a combination thereof. A photoresist 66 may be deposited and patterned over the BARC layer 64. After developing and removing a portion of the photoresist 66, an etch step is further performed into the BARC layer 64 to expose the portion of the hard mask layer 62 over the NMOS FinFET 300. FIG. 20 illustrates the transferring of the photoresist 66 pattern to the hard mask layer 62 to expose the NMOS FinFET 300.

In FIG. 21, the dummy gate 38 of the NMOS FinFET 300 is removed and a channel region below the dummy gate 38 is removed. A first etch may be performed to form opening 68 and a second etch may be performed to form opening 70 in the semiconductor strip 24. This step may be performed in a similar manner as described above in reference to FIGS. 12A through 12C and will not be repeated herein. FIG. 22 illustrates the formation of a V-shape opening 72 below the opening 70. This step may be performed in a similar manner as described above in reference to FIGS. 13A through 13C and will not be repeated herein.

FIG. 23 illustrates the formation of a V-shaped NMOS replacement channel region 74 in the openings 70 and 72. This step may be performed in a similar manner as described above in reference to FIGS. 14A through 14C and will not be repeated herein. FIG. 24 illustrates the removal of the hard mask layer 62 and the ESL 60 over the PMOS FinFET device 400. This step may be performed by an etch comprising H₃PO₄, a DHF treatment, the like, or a combination thereof.

FIG. 25 illustrates the formation of another ESL 76 and a hard mask layer 78 over the ILD 40 and the NMOS and PMOS FinFETs 300 and 400. The ESL 76 and the hard mask layer 78 may be deposited in the opening 68, wherein the ESL 76 adjoins the gate spacers 34 and at top surface of the V-shaped NMOS replacement channel region 74. This step may be performed in a similar manner as described above in reference to FIG. 18 and will not be repeated herein. FIG. 26 illustrates the formation of another BARC layer 80 and a photoresist 82 that is patterned to expose the hard mask layer 78 over the PMOS FinFET 400. This step may be performed in a similar manner as described above in reference to FIG. 19 and will not be repeated herein. FIG. 27 illustrates the patterning of the hard mask layer 78 and the ESL 76 to expose the dummy gate 38 over the PMOS FinFET 400. This step may be performed in a similar manner as described above in reference to FIG. 20 and will not be repeated herein.

FIG. 28 illustrates the removal of the dummy gate 38 over the PMOS FinFET 400 and a channel region below the dummy gate 38 is removed. This step may be performed in a similar manner as described above in reference to FIG. 21 and will not be repeated herein. FIG. 29 illustrates the formation of PMOS replacement channel region 84 in the opening 83. This step may be performed in a similar manner as described above in reference to FIGS. 14A through 14C and will not be repeated herein. In an embodiment, the PMOS replacement channel region 84 may have a shallower depth than the NMOS replacement channel region 74 (see FIG. 29). In another embodiment, the PMOS replacement channel region 84 may have a different shape than the NMOS replacement channel region 74 (see FIG. 29). As described above in ref-

erence to FIGS. 14A through 14C, the NMOS replacement channel region 74 may comprise different materials than the PMOS replacement channel region 84, although the materials may be the same. In another embodiment, the processing flow may form the NMOS FinFET 300 first or the PMOS FinFET 400 first.

FIG. 30 illustrates the removal of the hard mask layer 78 and the ESL 76. This step may be performed in a similar manner as described above in reference to FIG. 24 and will not be repeated herein. After the removal of the hard mask layer 78 and the ESL 76, the fins may be formed by recessing the dielectric layer (not shown) surround the semiconductor strips 24. This step may be performed in a similar manner as described above in reference to FIGS. 15A through 15C and will not be repeated herein. FIG. 31 illustrates the formation of the gate dielectric layer 86 and the gates 88 over the NMOS replacement channel region 74 and the PMOS replacement channel region 84. This step may be performed in a similar manner as described above in reference to FIGS. 16A through 16C and will not be repeated herein.

An embodiment is a method for forming a FinFET device, the method comprising forming a semiconductor strip over a semiconductor substrate, wherein the semiconductor strip is disposed in a dielectric layer, forming a gate over the semiconductor strip and the dielectric layer, and forming a first recess and a second recess in the semiconductor strip, wherein the first recess is on an opposite side of the gate from the second recess. The method further comprises forming a source region in the first recess and a drain region in the second recess, and recessing the dielectric layer, wherein a first portion of the semiconductor strip extends above a top surface of the dielectric layer forming a semiconductor fin.

Another embodiment is a method of forming a FinFET device, the method comprising forming a semiconductor strip over a semiconductor substrate, wherein the semiconductor strip is disposed in a dielectric layer, forming a first dummy gate over the semiconductor strip and the dielectric layer, forming a first set of gate spacers on opposite sides of the first dummy gate, etching recesses in the semiconductor strip, and epitaxially growing a first source region in one of the recesses and a first drain region in another one of the recesses. The method further comprises removing the first dummy gate to expose a first channel region in the semiconductor strip, removing the first channel region in the semiconductor strip, forming a first replacement channel region in the semiconductor strip, etching the dielectric layer, wherein the first replacement channel region extends above a top surface of the dielectric layer, and wherein a portion of the semiconductor strip extends above the top surface of the dielectric layer forming a semiconductor fin, and forming a first active gate over the first replacement channel region.

Yet another embodiment is a FinFET device comprising a dielectric layer on a semiconductor substrate, a semiconductor fin extending from the semiconductor substrate, wherein the semiconductor fin is disposed in the dielectric layer, and a first source region and a first drain region disposed in the semiconductor fin, wherein the first source region and the first drain region comprise a first epitaxial material, wherein the first source region and the first drain region have sidewalls that are substantially orthogonal to a top surface of the semiconductor substrate. The FinFET device further comprises a first channel region in the semiconductor fin, wherein the first channel region is laterally between the first source region and the first drain region, and a first gate structure over the semiconductor fin, wherein the first gate structure is over the first channel region.

Although the present embodiments and their advantages have been described in detail, it should be understood that various changes, substitutions, and alterations can be made herein without departing from the spirit and scope of the disclosure as defined by the appended claims. Moreover, the scope of the present application is not intended to be limited to the particular embodiments of the process, machine, manufacture, composition of matter, means, methods, and steps described in the specification. As one of ordinary skill in the art will readily appreciate from the disclosure, processes, machines, manufacture, compositions of matter, means, methods, or steps, presently existing or later to be developed, that perform substantially the same function or achieve substantially the same result as the corresponding embodiments described herein may be utilized according to the present disclosure. Accordingly, the appended claims are intended to include within their scope such processes, machines, manufacture, compositions of matter, means, methods, or steps.

What is claimed is:

1. A method for forming a FinFET device, the method comprising:
 - forming a semiconductor strip over a semiconductor substrate, wherein the semiconductor strip is disposed in a dielectric layer;
 - forming a gate over the semiconductor strip and the dielectric layer;
 - forming a first recess and a second recess in the semiconductor strip, wherein the first recess is on an opposite side of the gate from the second recess;
 - forming a source region in the first recess and a drain region in the second recess; and
 - recessing the dielectric layer, wherein a first portion of the semiconductor strip extends above a top surface of the dielectric layer forming a semiconductor fin.
2. The method of claim 1, wherein the source region and the drain region have sidewalls substantially orthogonal to a top surface of the semiconductor substrate.
3. The method of claim 1, wherein the source region and the drain region have top surfaces substantially parallel to a top surface of the semiconductor substrate.
4. The method of claim 1, wherein the first portion of the semiconductor strip comprises the source region and the drain region.
5. The method of claim 1, wherein the forming the source region in the first recess and the drain region in the second recess further comprises epitaxially growing the source region in the first recess and the drain region in the second recess.
6. The method of claim 1 further comprising:
 - before the step of recessing the dielectric layer, forming gate spacers on opposite sides of the gate;
 - depositing an etch stop layer (ESL) over the semiconductor strip, the gate, the source region, the drain region, and the dielectric layer;
 - depositing an inter-layer dielectric (ILD) over the ESL;
 - planarizing the ILD and the ESL to expose a top surface of the gate;
 - removing the gate to form an opening between the gate spacers;
 - performing the step of recessing the dielectric layer, wherein the dielectric layer is recessed below the opening between the gate spacers; and
 - forming a second gate in the opening between the gate spacers.
7. The method of claim 1, wherein the recessing the dielectric layer comprises performing a chemical oxide reaction

11

comprising a CERTAS® etch, a Siconi etch, a DHF treatment, or a combination thereof.

8. A method of forming a FinFET device, the method comprising:

forming a semiconductor strip over a semiconductor substrate, wherein the semiconductor strip is disposed in a dielectric layer;

forming a first dummy gate over the semiconductor strip and the dielectric layer;

forming a first set of gate spacers on opposite sides of the first dummy gate;

etching recesses in the semiconductor strip;

epitaxially growing a first source region in one of the recesses and a first drain region in another one of the recesses;

removing the first dummy gate to expose a first channel region in the semiconductor strip;

removing the first channel region in the semiconductor strip;

forming a first replacement channel region in the semiconductor strip;

etching the dielectric layer, wherein the first replacement channel region extends above a top surface of the dielectric layer, and wherein a portion of the semiconductor strip extends above the top surface of the dielectric layer forming a semiconductor fin; and

forming a first active gate over the first replacement channel region.

9. The method of claim 8, wherein the forming the first replacement channel region in the semiconductor strip comprises epitaxially growing the first replacement channel region in the semiconductor strip.

10. The method of claim 8, wherein the first replacement channel region has a V-shaped bottom surface extending into the semiconductor strip.

11. The method of claim 8, wherein the first replacement channel region has a substantially planar bottom surface that is substantially parallel to a top surface of the semiconductor substrate.

12. The method of claim 8 further comprising:

before the step of etching the dielectric layer, forming a second dummy gate over the semiconductor fin;

forming a second set of gate spacers on opposite sides of the second dummy gate;

epitaxially growing a second source region in one of the recesses and a second drain region in another one of the recesses;

after the step of forming the first replacement channel region, removing the second dummy gate to expose a second channel region in the semiconductor strip;

removing the second channel region in the semiconductor strip;

forming a second replacement channel region in the semiconductor strip;

12

performing the step of etching the dielectric layer, wherein the first replacement channel region and the second replacement channel region extend above a top surface of the dielectric layer; and

forming a second active gate over the second replacement channel region.

13. The method of claim 12, wherein the first replacement channel region comprises a different material than the second replacement channel region.

14. The method of claim 12, wherein the first replacement channel region has a V-shaped bottom surface extending into the semiconductor strip, and wherein the second replacement channel region has a substantially planar bottom surface that is substantially parallel to a top surface of the semiconductor substrate.

15. The method of claim 12, wherein the first replacement channel region has a shallower depth than the second replacement channel region.

16. The method of claim 12, wherein the first source region, the first drain region, the first active gate, and the first replacement channel region forms an NMOS FinFET device, and wherein the second source region, the second drain region, the second active gate, and the second replacement channel region forms a PMOS FinFET device.

17. A method comprising:

forming a semiconductor strip in a dielectric layer over a semiconductor substrate;

forming a first gate over a first channel region in the semiconductor strip;

forming recesses in the semiconductor strip, the recesses being on opposite sides of the first channel region;

forming a source region in one of the recesses and a drain region in another one of the recesses; and

recessing the dielectric layer to expose a top portion of the semiconductor strip above a top surface of the recessed dielectric layer, the top portion of the semiconductor strip forming a semiconductor fin.

18. The method of claim 17 further comprising:

forming gate spacers on opposite sides of the first gate;

before the step of recessing the dielectric layer, removing the first gate to form an opening between the gate spacers; and

after the step of recessing the dielectric layer, forming a second gate in the opening between the gate spacers.

19. The method of claim 18 further comprising before forming the second gate in the opening between the gate spacers, replacing the first channel region in the semiconductor strip with a second channel region in the semiconductor strip.

20. The method of claim 17, wherein the source region and the drain region have sidewalls substantially orthogonal to a top surface of the semiconductor substrate, and wherein the source region and the drain region have top surfaces substantially parallel to the top surface of the semiconductor substrate.

* * * * *