

(12) **United States Patent**
Tsai et al.

(10) **Patent No.:** **US 10,263,108 B2**
(45) **Date of Patent:** **Apr. 16, 2019**

(54) **METAL-INSENSITIVE EPITAXY FORMATION**

(71) Applicant: **Taiwan Semiconductor Manufacturing Company, Ltd.**,
Hsin-Chu (TW)

(72) Inventors: **Chun Hsiung Tsai**, Hsinchu County (TW); **Yuan-Ko Hwang**, Hsinchu (TW)

(73) Assignee: **Taiwan Semiconductor Manufacturing Company, Ltd.**,
Hsin-Chu (TW)

(*) Notice: Subject to any disclaimer, the term of this patent is extended or adjusted under 35 U.S.C. 154(b) by 0 days.

(21) Appl. No.: **14/597,115**

(22) Filed: **Jan. 14, 2015**

(65) **Prior Publication Data**
US 2016/0056290 A1 Feb. 25, 2016

Related U.S. Application Data

(60) Provisional application No. 62/040,880, filed on Aug. 22, 2014.

(51) **Int. Cl.**
H01L 29/78 (2006.01)
H01L 21/02 (2006.01)
(Continued)

(52) **U.S. Cl.**
CPC **H01L 29/7848** (2013.01); **H01L 21/0245** (2013.01); **H01L 21/0262** (2013.01);
(Continued)

(58) **Field of Classification Search**

CPC H01L 29/66636; H01L 29/7848; H01L 29/165; H01L 29/167; H01L 29/784; H01L 29/66628
See application file for complete search history.

(56) **References Cited**

U.S. PATENT DOCUMENTS

7,667,271 B2 2/2010 Yu et al.
8,362,575 B2 1/2013 Kwok et al.
(Continued)

FOREIGN PATENT DOCUMENTS

KR 10-2012-0086369 8/2012

OTHER PUBLICATIONS

Y. Bogumilowicz et al., "Chemical vapour etching of Si, SiGe and Ge with HCl; applications to the formation of thin relaxed SiGe buffers and to the revelation of threading dislocations," Institute of Physics Publishing, Dec. 17, 2004, pp. 127-134, Semicond. Sci. Technol. 20 (2005), France.

(Continued)

Primary Examiner — David C Spalla

(74) *Attorney, Agent, or Firm* — Haynes and Boone, LLP

(57) **ABSTRACT**

The present disclosure provides a method forming a field effect transistor (FET) in accordance with some embodiments. The method includes performing an etching process to a semiconductor substrate, thereby forming recesses in source and drain (S/D) regions of the semiconductor substrate; forming a passivation material layer of a first semiconductor in the recesses; and epitaxially growing a second semiconductor material, thereby forming S/D features in the recesses, wherein the S/D features are separated from the semiconductor substrate by the passivation material layer.

29 Claims, 23 Drawing Sheets

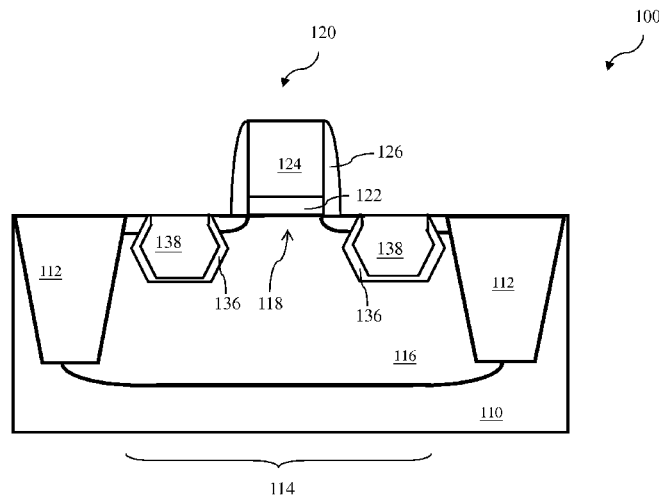

| | | |
|------|--|--|
| (51) | <p>Int. Cl. <i>H01L 21/04</i> (2006.01) <i>H01L 21/3065</i> (2006.01) <i>H01L 29/16</i> (2006.01) <i>H01L 29/165</i> (2006.01) <i>H01L 29/66</i> (2006.01)</p> | <p>2010/0093147 A1* 4/2010 Liao H01L 21/28123 438/300 2011/0027955 A1* 2/2011 Woon H01L 21/26506 438/285 2011/0068407 A1 3/2011 Yeh et al. 2012/0091469 A1* 4/2012 Park H01L 29/0847 257/77 2012/0295427 A1* 11/2012 Bauer H01L 21/02532 438/494 2013/0011983 A1 1/2013 Tsai et al. 2013/0049101 A1* 2/2013 Hsiao H01L 29/66636 257/329 2013/0328126 A1 12/2013 Tsai et al. 2014/0091308 A1* 4/2014 Dasgupta H01L 29/7784 257/76 2014/0197455 A1* 7/2014 Lee H01L 29/78 257/192 2014/0252412 A1 9/2014 Tsai et al. 2014/0264348 A1* 9/2014 Tsai C30B 25/165 257/57 2014/0264636 A1* 9/2014 Tsai H01L 29/66636 257/408 2015/0155386 A1* 6/2015 Hung H01L 29/7848 257/401</p> |
|------|--|--|

(56) **References Cited**

U.S. PATENT DOCUMENTS

| | | | |
|------------------|---------|-----------------|--------------------------|
| 8,367,498 B2 | 2/2013 | Chang et al. | |
| 8,404,546 B2 | 3/2013 | Woon et al. | |
| 8,440,517 B2 | 5/2013 | Lin et al. | |
| 8,497,528 B2 | 7/2013 | Lee et al. | |
| 8,598,003 B2 | 12/2013 | Murthy et al. | |
| 8,610,240 B2 | 12/2013 | Lee et al. | |
| 8,680,576 B2 | 3/2014 | Ching et al. | |
| 8,723,272 B2 | 5/2014 | Liu et al. | |
| 8,729,627 B2 | 5/2014 | Cheng et al. | |
| 8,729,634 B2 | 5/2014 | Shen et al. | |
| 8,785,285 B2 | 7/2014 | Tsai et al. | |
| 8,796,759 B2 | 8/2014 | Perng et al. | |
| 8,809,139 B2 | 8/2014 | Huang et al. | |
| 8,828,823 B2 | 9/2014 | Liu et al. | |
| 8,836,016 B2 | 9/2014 | Wu et al. | |
| 8,841,701 B2 | 9/2014 | Lin et al. | |
| 8,847,293 B2 | 9/2014 | Lee et al. | |
| 8,853,025 B2 | 10/2014 | Zhang et al. | |
| 2006/0234504 A1* | 10/2006 | Bauer | C23C 16/04 438/674 |
| 2007/0249168 A1* | 10/2007 | Rotondaro | H01L 21/30608 438/700 |
| 2008/0315254 A1* | 12/2008 | Fukuda | H01L 21/02532 257/190 |

OTHER PUBLICATIONS

V. Destefanis et al., "High pressure in situ HC1 etching of Si_{1-x}Ge_x versus Si for advanced devices," Semiconductor Science and Technology, Sep. 16, 2008, pp. 9, Semicond. Sci. Technol. 23 (2008), France.

V. Destefanis et al., Low-thermal surface preparation, HC1 etch and Si/SiGe selective epitaxy on (1 1 0) silicon surfaces, Semiconductor Science and Technology, Sep. 16, 2008, pp. 9, Semicond. Sci. Technol. 23 (2008), France.

Y. Bogumilowicz et al., "Selective chemical vapour etching of Si_{1-x}Ge_x versus Si with gaseous HC1," Semiconductor Science and Technology, Oct. 18, 2006, pp. 1668-1674, Semicond. Sci. Technol. 21 (2006), France.

J. M. Hartmann et al., Tensile-strained Si layers grown on Si_{0.6}Ge_{0.4} and Si_{0.5}Ge_{0.5} virtual substrates: I. Film thickness and morphology, Semiconductor Science and Technology, Mar. 7, 2007, pp. 354-361, Semicond. Sci. Technol. 22 (2007), France.

* cited by examiner

100

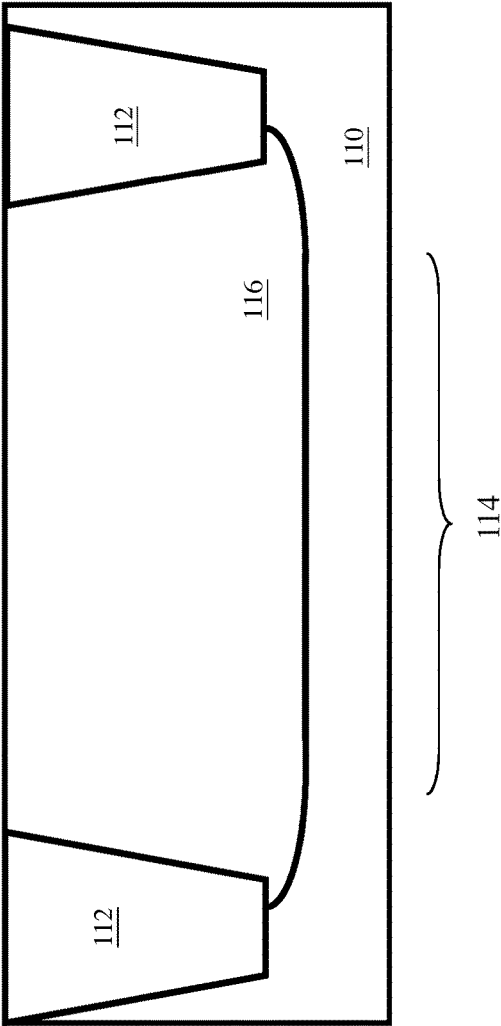

Fig. 1A

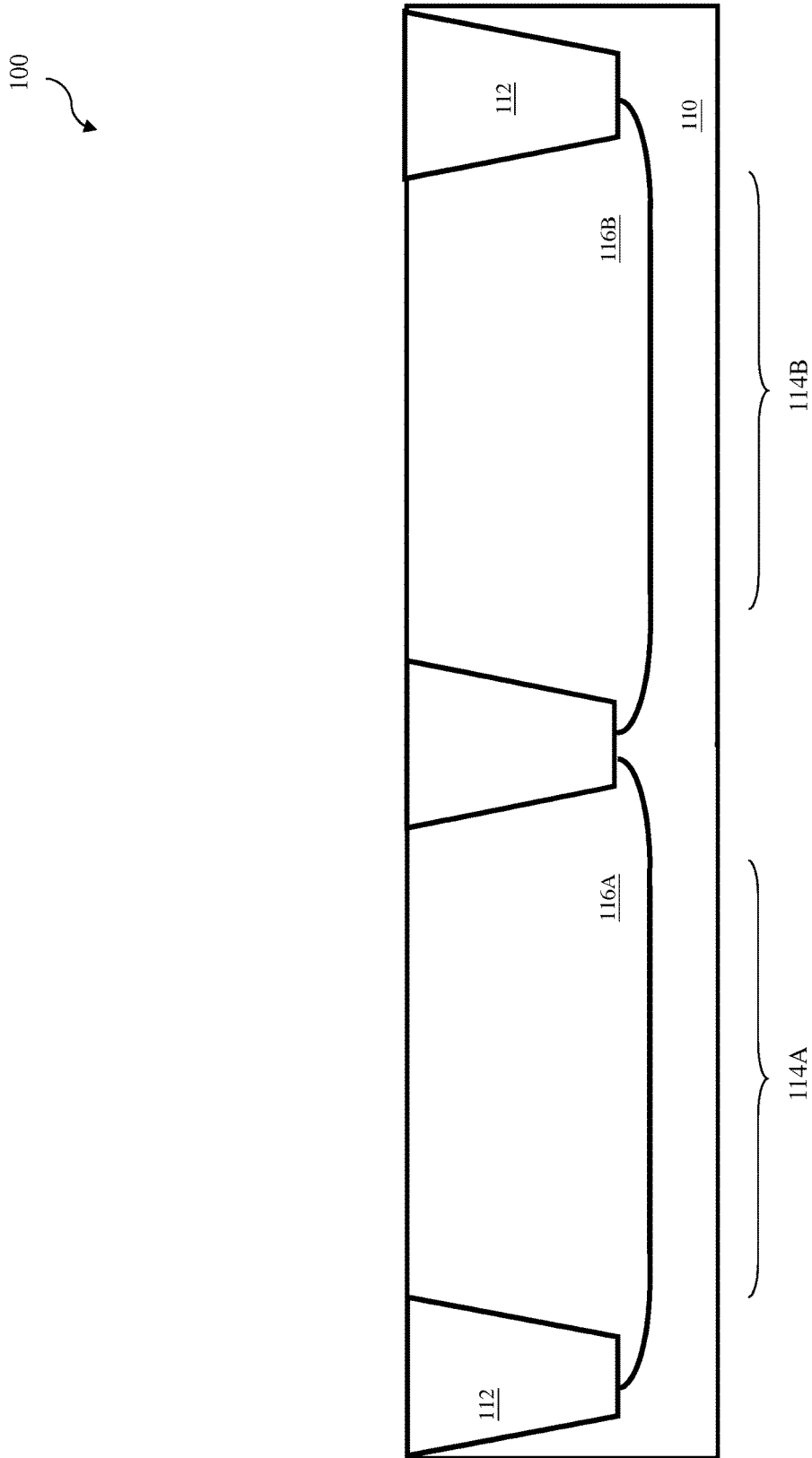

Fig. 1B

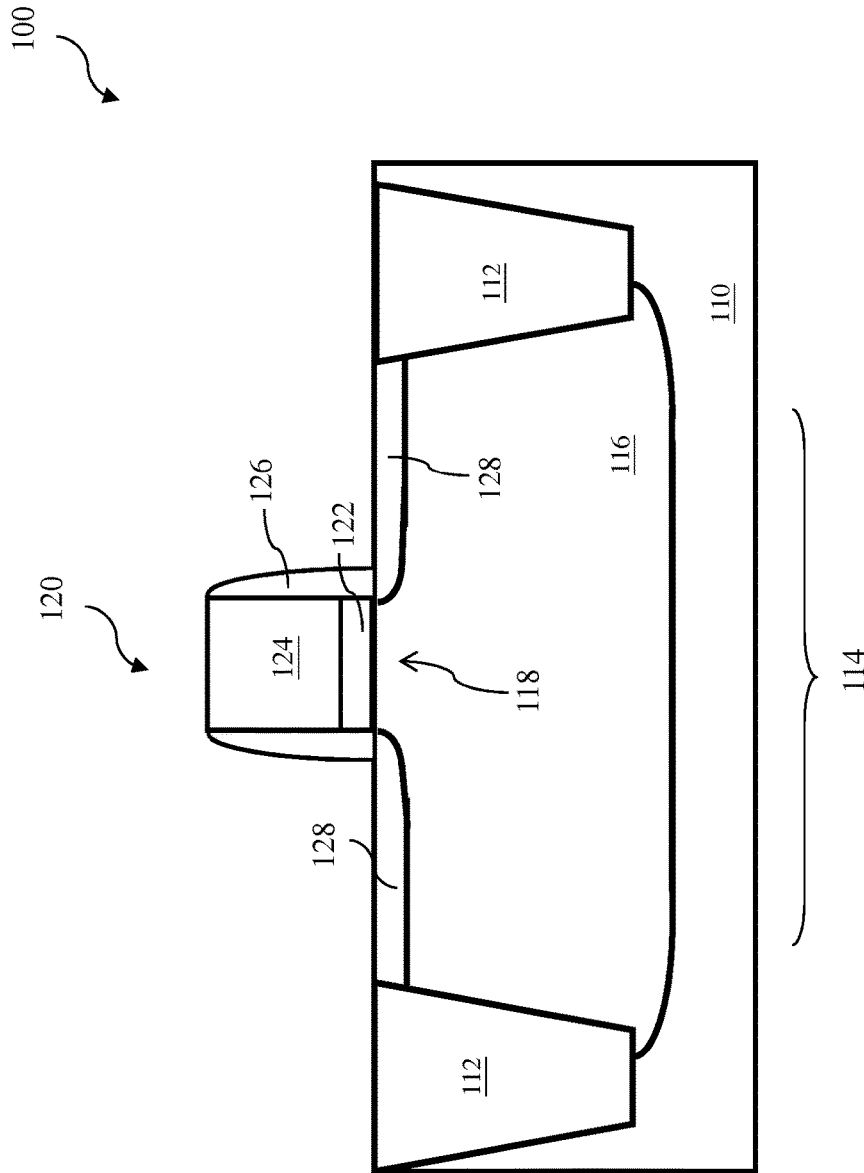

Fig. 2

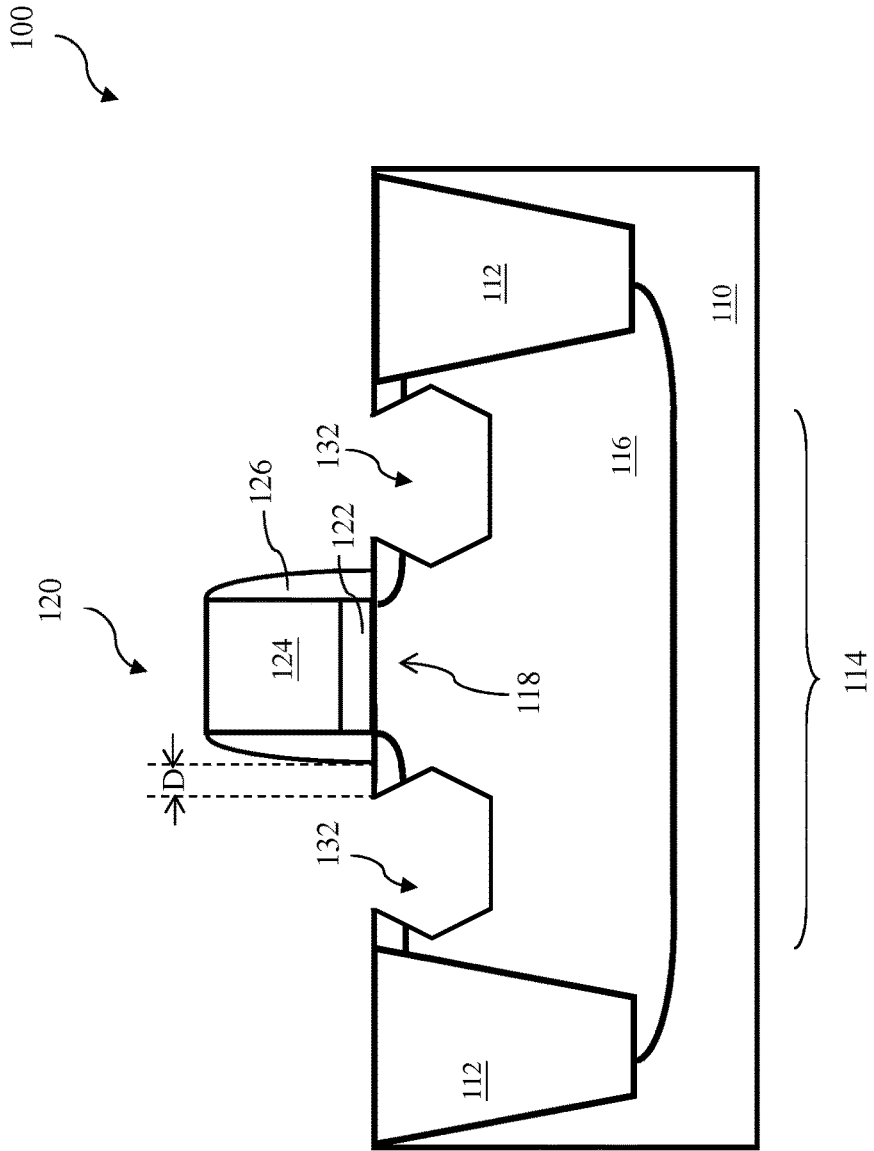

Fig. 3

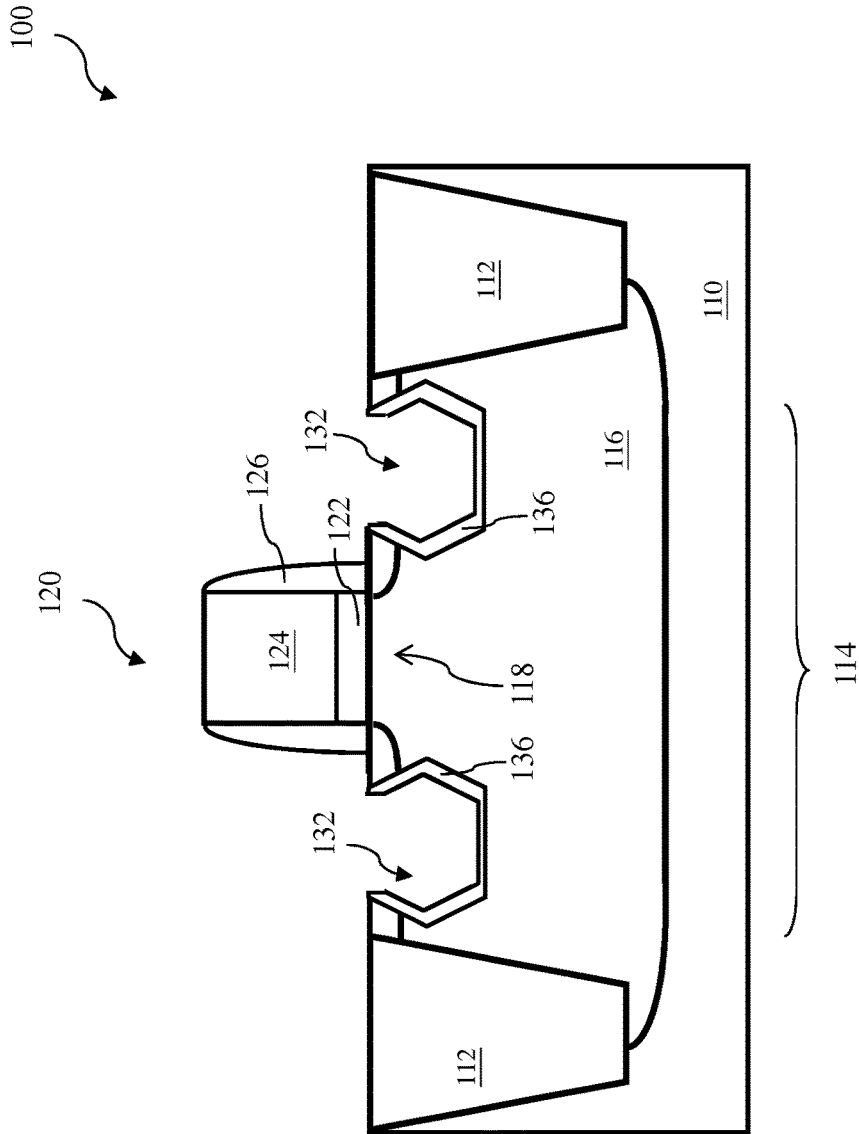

Fig. 4A

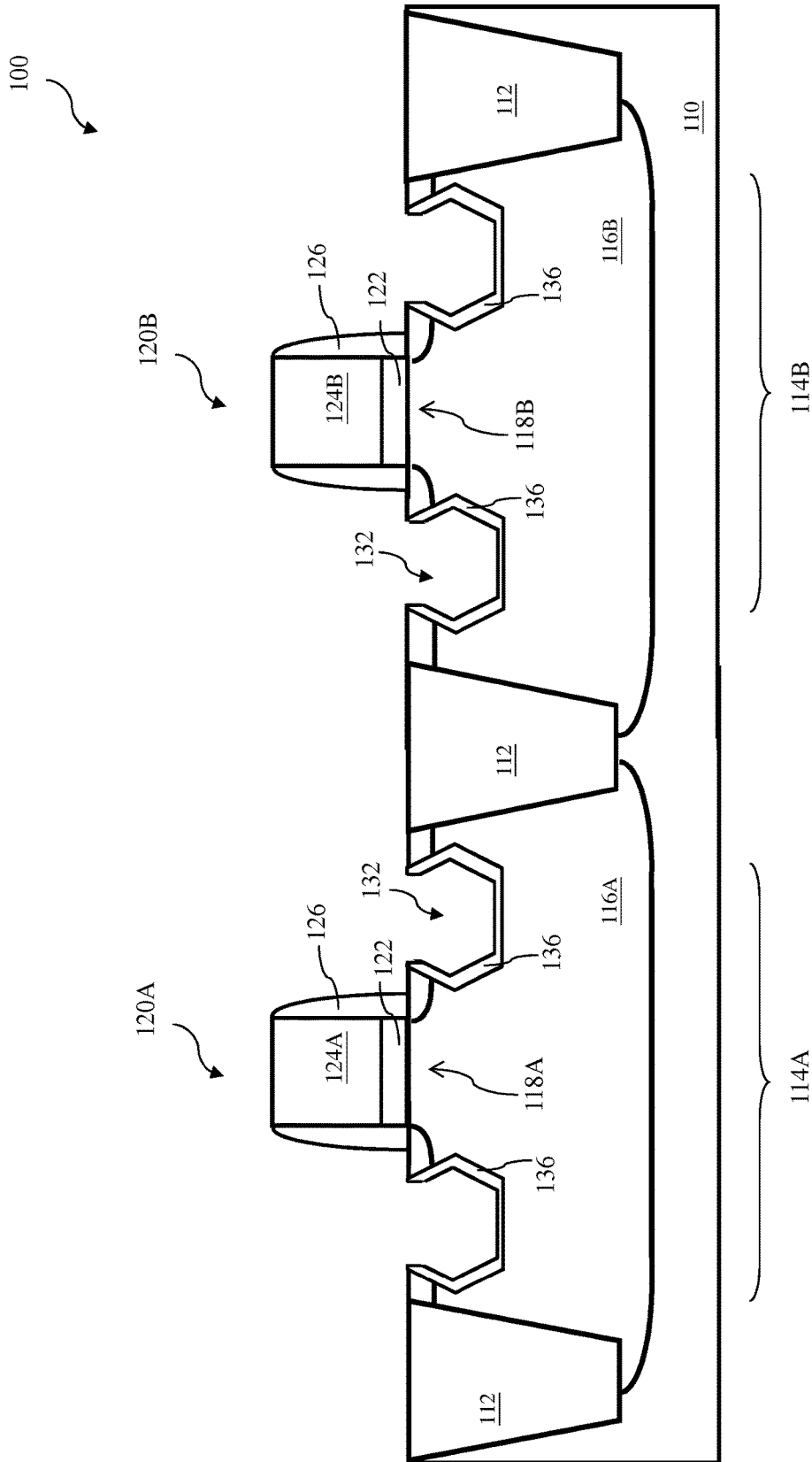

Fig. 4B

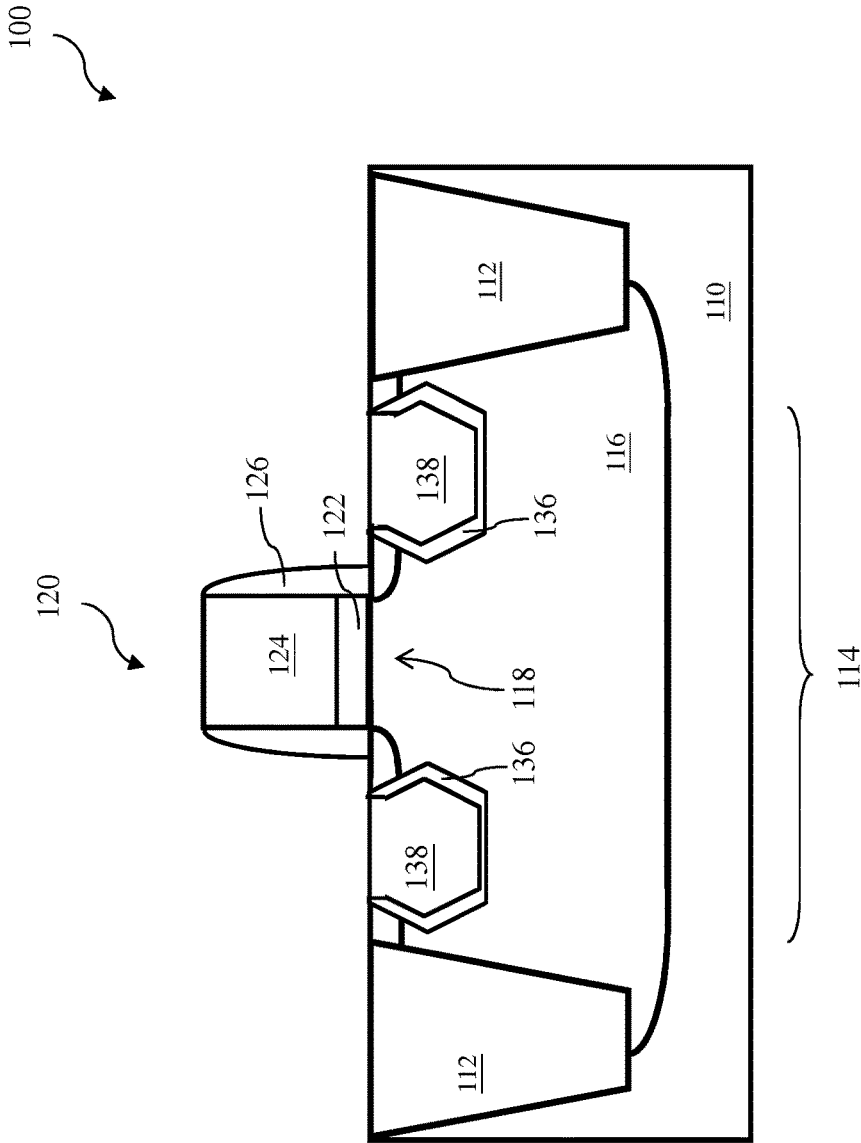

Fig. 5A

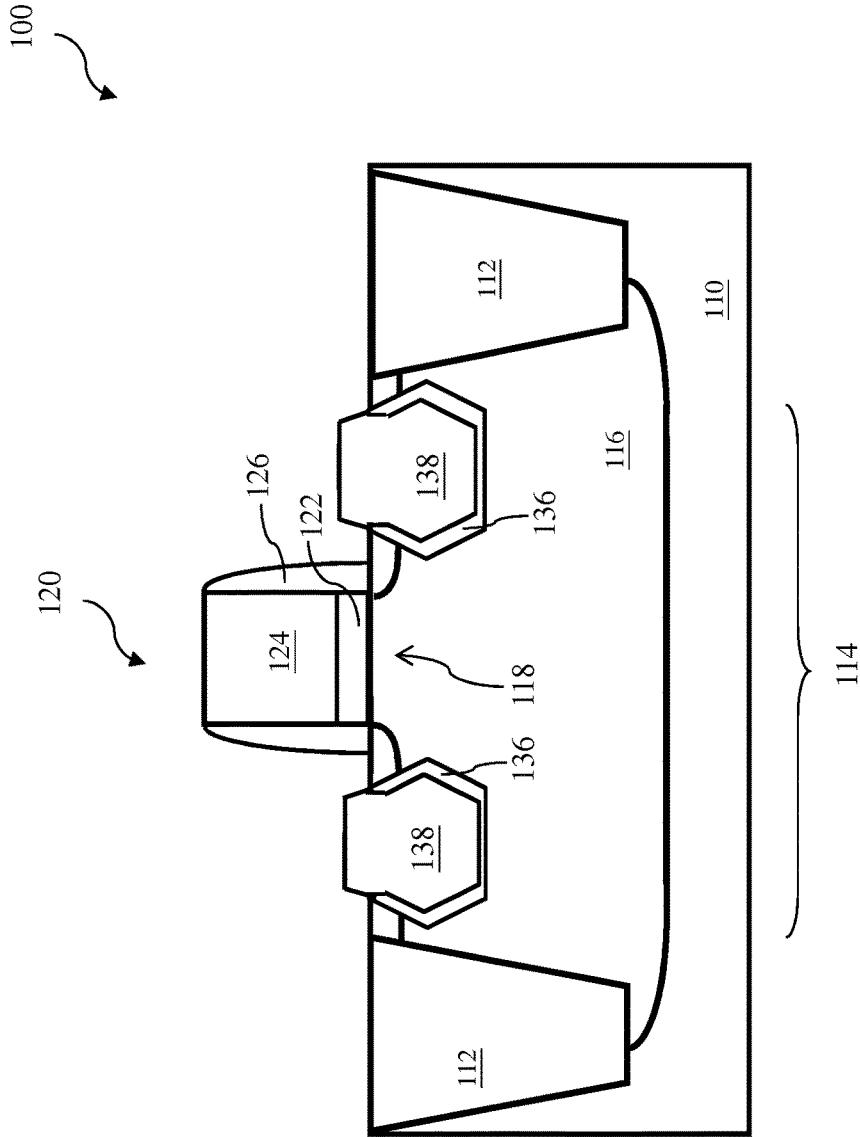

Fig. 6

100

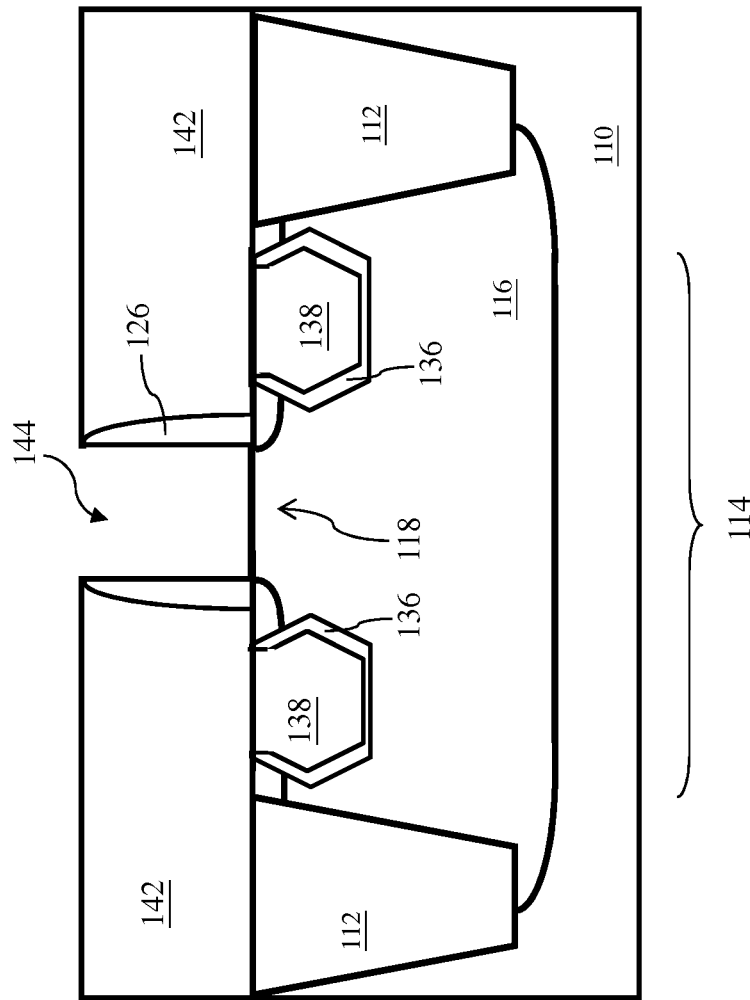

Fig. 7

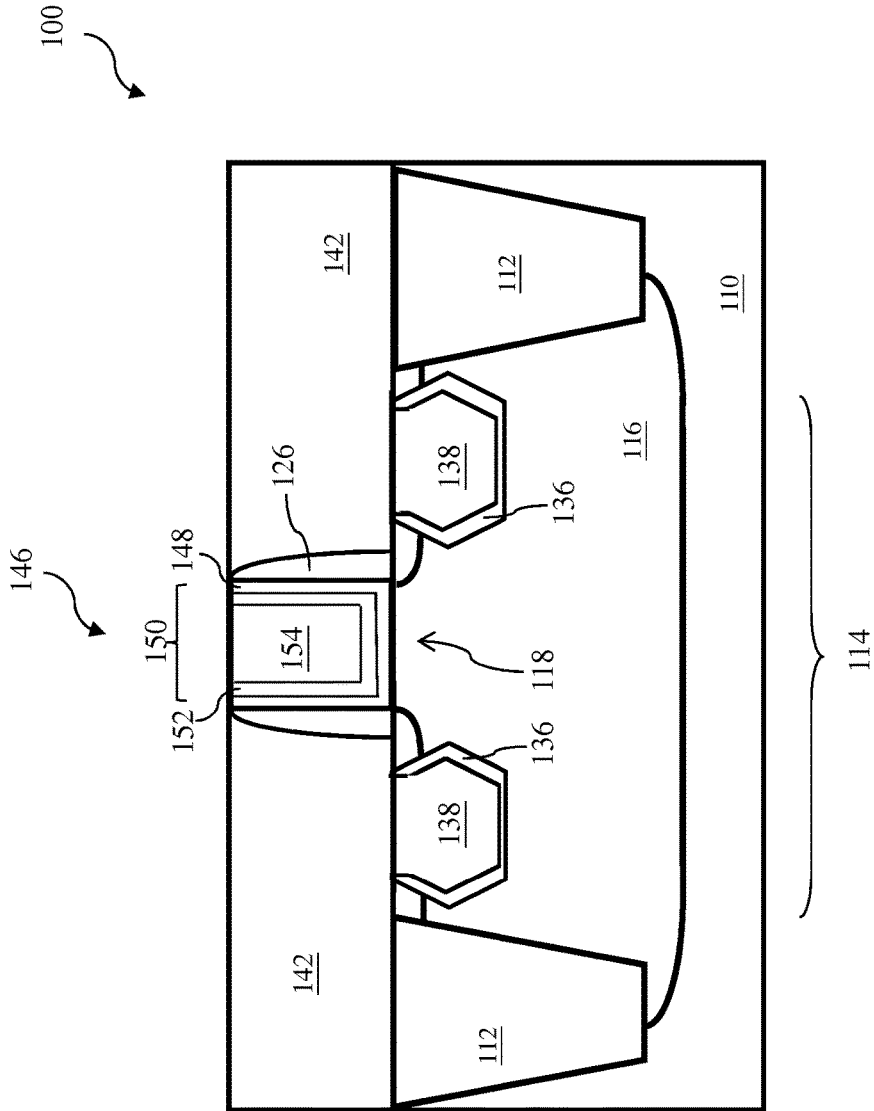

Fig. 8A

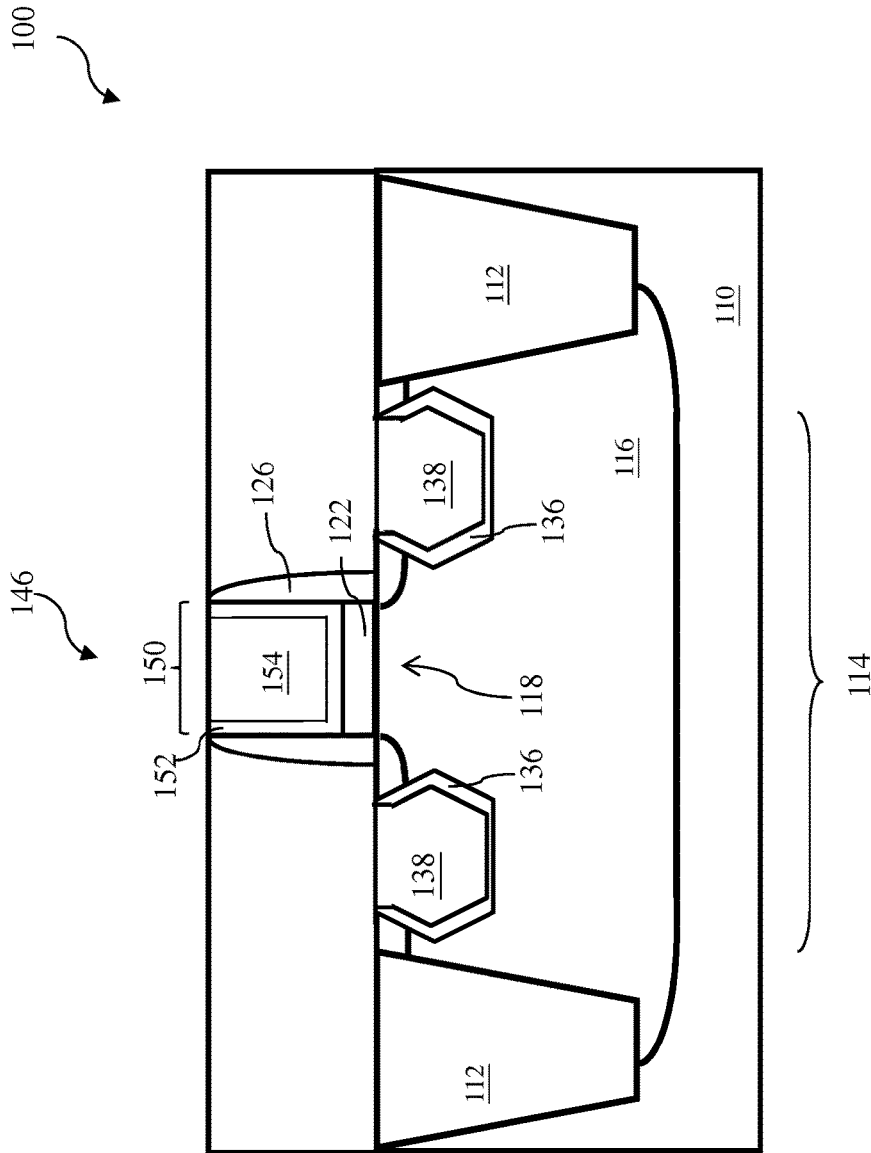

Fig. 9

160

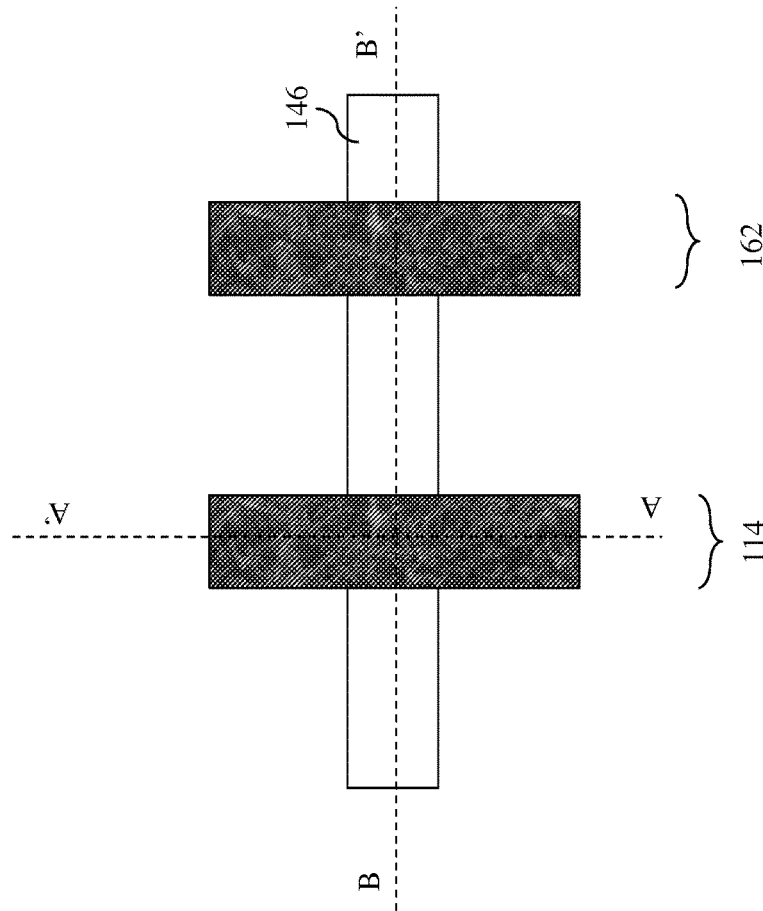

Fig. 10

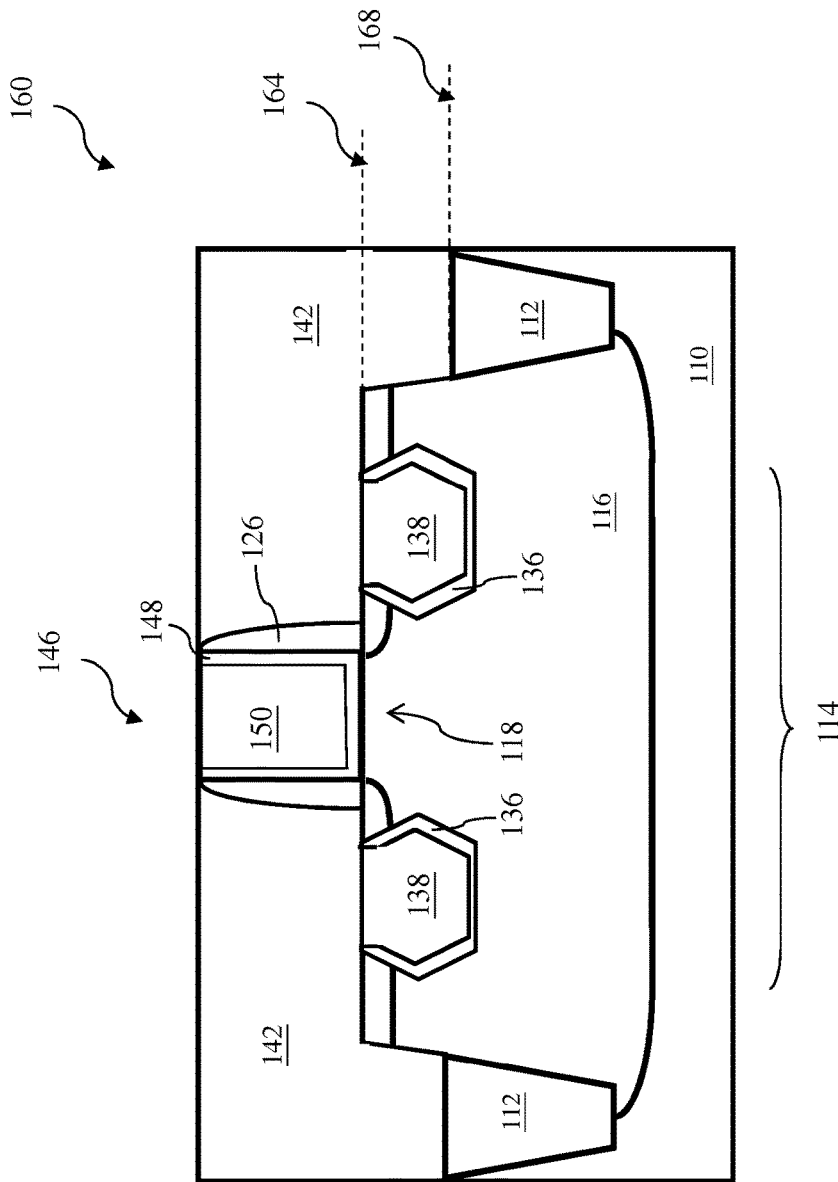

Fig. 11

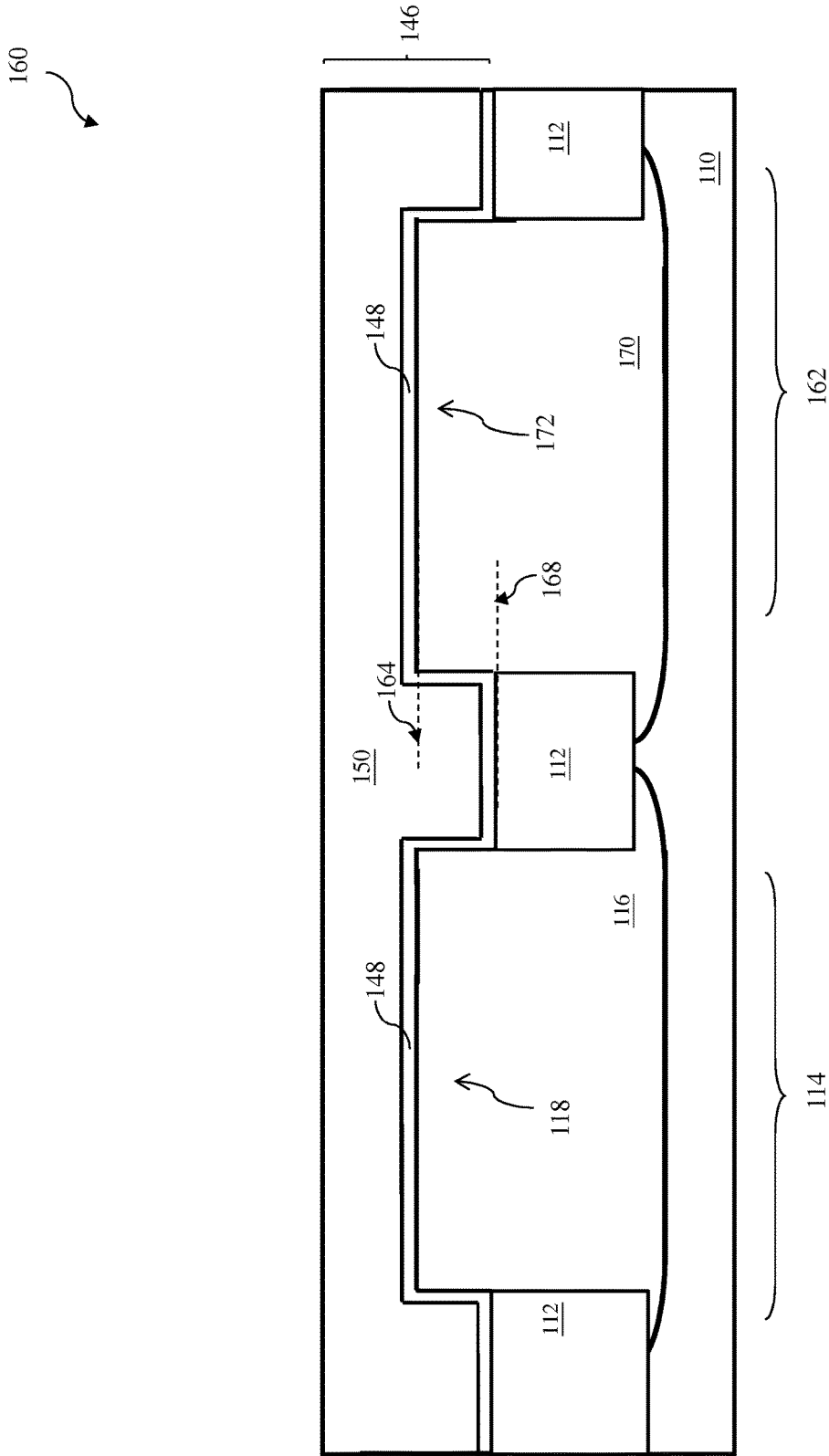

Fig. 12

200

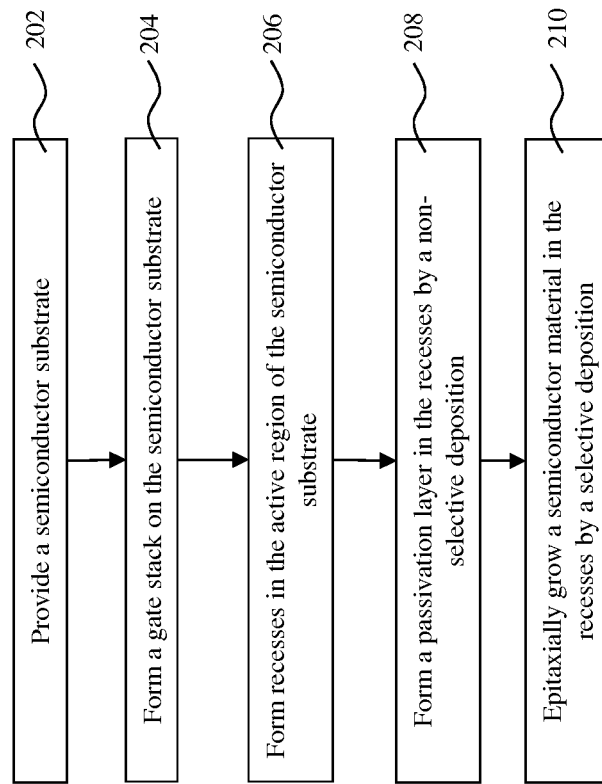

Fig. 13

220

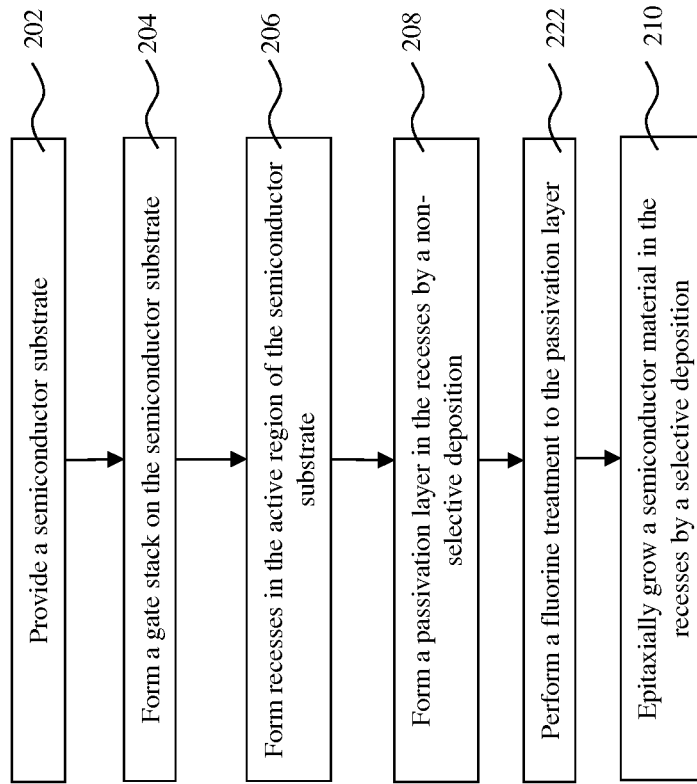

Fig. 14

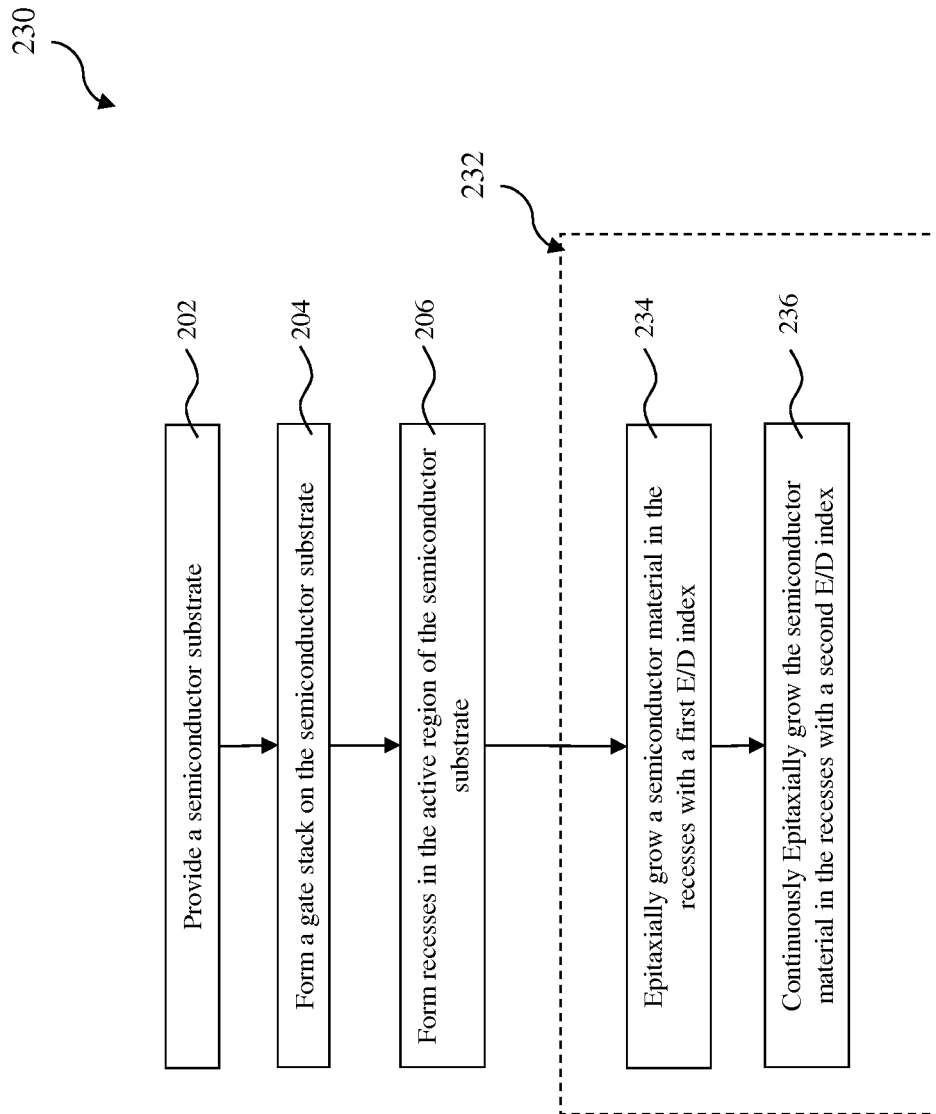

Fig. 15

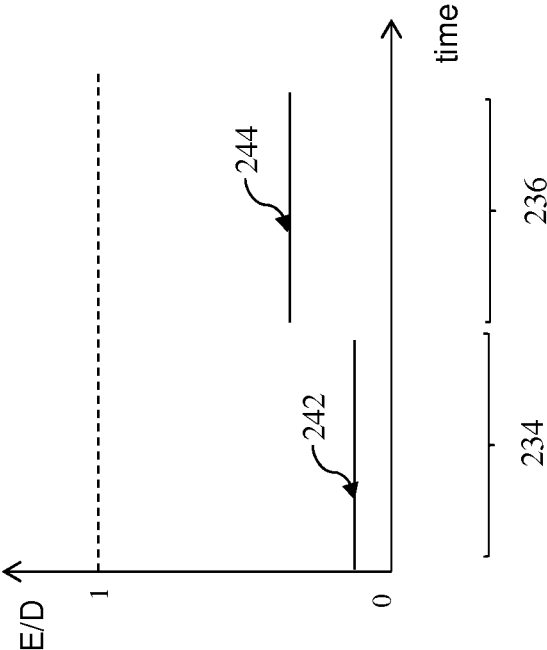

Fig. 16

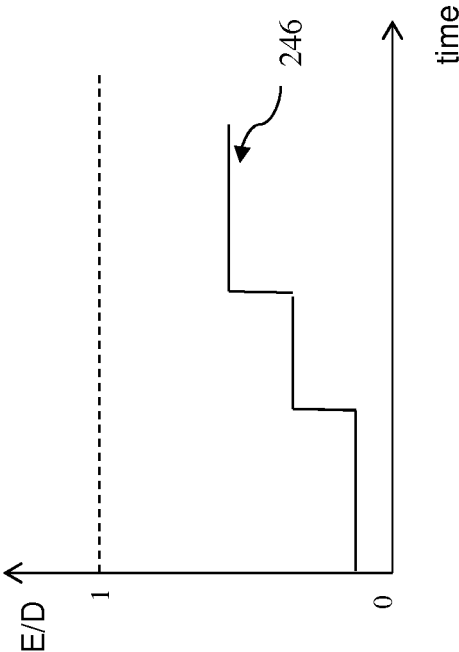

Fig. 17

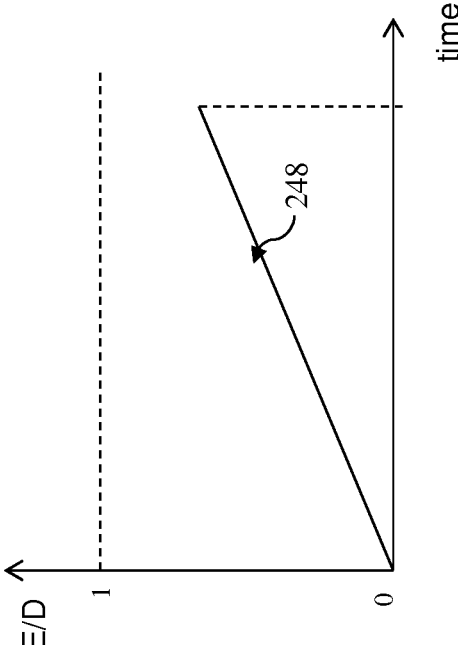

Fig. 18

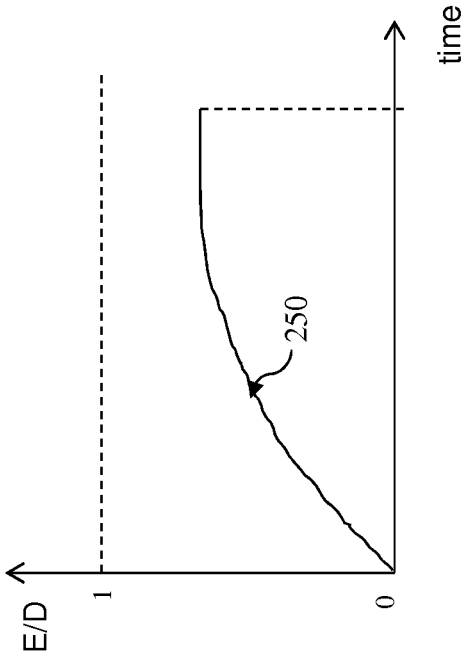

Fig. 19

1

METAL-INSENSITIVE EPITAXY FORMATION

This application claims the benefit of U.S. Provisional Application 62/040,880 entitled "METAL-INSENSITIVE EPITAXY FORMATION," filed Aug. 22, 2014, herein incorporated by reference in its entirety.

BACKGROUND

The semiconductor industry has progressed into nanometer technology process nodes in pursuit of higher device density, higher performance, and lower cost. In the course of IC evolution, functional density (i.e., the number of interconnected devices per chip area) has generally increased while geometry size (i.e., the smallest component (or line) that can be created using a fabrication process) has decreased. This scaling down process generally provides benefits by increasing production efficiency and lowering associated costs. Despite groundbreaking advances in materials and fabrication, scaling planar device such as the conventional MOSFET has proven challenging. For example, such scaling-down also produces a relatively high power dissipation value. To overcome these challenges, IC industries look to novel structures and fabrication to deliver improved performance. One avenue of inquiry is the development of strained field effect transistor (FET) with enhanced mobility. However, the existing structure and fabrication method present issues associated with the metal contamination, which introduces device defects and other performance concerns.

Therefore, there is a need for a structure and method for a FET device to address these concerns for enhanced performance and reduced defects.

BRIEF DESCRIPTION OF THE DRAWINGS

Aspects of the present disclosure are best understood from the following detailed description when read with the accompanying figures. It is emphasized that, in accordance with the standard practice in the industry, various features are not drawn to scale. In fact, the dimensions of the various features may be arbitrarily increased or reduced for clarity of discussion.

FIGS. 1A, 2, 3, 4A, 5A, 7 and 8A are sectional views of a semiconductor structure at various fabrication stages constructed in accordance with some embodiments.

FIGS. 1B, 4B, 5B and 8B are sectional views of a semiconductor structure at various fabrication stages constructed in accordance with some other embodiments.

FIG. 6 is a sectional view of a semiconductor structure constructed according to other embodiments.

FIG. 9 is a sectional view of a semiconductor structure constructed according to other embodiments.

FIG. 10 is a top view of a semiconductor structure constructed in accordance with some embodiments.

FIGS. 11-12 are sectional views of the semiconductor structure of FIG. 10 constructed in accordance with some embodiments.

FIG. 13 is a flowchart of a method making a semiconductor structure constructed according to various aspects of the present disclosure in some embodiments.

FIG. 14 is a flowchart of a method making a semiconductor structure constructed according to various aspects of the present disclosure in some other embodiments.

2

FIG. 15 is a flowchart of a method making a semiconductor structure constructed according to various aspects of the present disclosure in some other embodiments.

FIG. 16 illustrates a deposition process in the method of FIG. 15 and the corresponding E/D factor in accordance with some embodiments.

FIG. 17 illustrates a deposition process in the method of FIG. 15 and the corresponding E/D factor in accordance with some other embodiments.

FIG. 18 illustrates a deposition process in the method of FIG. 15 and the corresponding E/D factor in accordance with some other embodiments.

FIG. 19 illustrates a deposition process in the method of FIG. 15 and the corresponding E/D factor in accordance with some other embodiments.

DETAILED DESCRIPTION

It is to be understood that the following disclosure provides many different embodiments, or examples, for implementing different features of various embodiments. Specific examples of components and arrangements are described below to simplify the present disclosure. These are, of course, merely examples and are not intended to be limiting. In addition, the present disclosure may repeat reference numerals and/or letters in the various examples. This repetition is for the purpose of simplicity and clarity and does not in itself dictate a relationship between the various embodiments and/or configurations discussed. Moreover, the formation of a first feature over or on a second feature in the description that follows may include embodiments in which the first and second features are formed in direct contact, and may also include embodiments in which additional features may be formed interposing the first and second features, such that the first and second features may not be in direct contact.

FIGS. 1A, 2, 3, 4A, 5A, 7 and 8A are sectional views of a semiconductor structure **100** at various fabrication stages constructed in accordance with some embodiments. FIGS. 1B, 4B, 5B and 8B are sectional views of the semiconductor structure at various fabrication stages constructed in accordance with some other embodiments. The semiconductor structure **100** and the method making the same are collectively described in accordance with some embodiments. In one embodiment, the semiconductor structure **100** includes one or more field effect transistor (FET).

Referring to FIG. 1A, the semiconductor structure **100** includes a semiconductor substrate **110**. The semiconductor substrate **110** includes silicon. Alternatively, the substrate includes germanium, silicon germanium or other proper semiconductor materials. In another embodiment, the semiconductor substrate **110** may include a buried dielectric material layer for isolation formed by a proper technology, such as a technology referred to as separation by implanted oxygen (SIMOX). In some embodiments, the substrate **110** may be a semiconductor on insulator, such as silicon on insulator (SOI).

As various examples for illustration, the semiconductor structure **100** includes other components or features. In some embodiments, isolation features, such as various shallow trench isolation (STI) features **112**, are formed in the semiconductor substrate **110** and define various semiconductor regions (or active regions) **114**. The semiconductor regions **114** are separated and isolated from each other by the STI features **112**. In one example, the top surface of the semiconductor substrate **110** and the top surfaces of the STI features **112** may be coplanar, resulting in a common top

surface. In another example, the top surface of the semiconductor substrate **110** and the top surfaces of the STI features **112** are not coplanar, resulting in a three-dimensional structure, such as a fin FET (FinFET) structure.

In some embodiments, the formation of the STI features **112** includes, forming a hard mask with openings that define the regions for STI features; etching the semiconductor substrate **110** through the openings of the hard mask to form trenches in the semiconductor substrate; depositing one or more dielectric material to fill in the trenches; and performing a chemical mechanical polishing (CMP) process. As one embodiment for illustration, the depth of the STI features **112** ranges between about 50 nm and about 500 nm. In one example, the formation of the hard mask includes depositing a hard mask layer; a lithography process to form a patterned resist layer on the hard mask layer; and etching the hard mask layer using the patterned resist layer as an etch mask. In some examples, the deposition of the dielectric material further includes thermal oxidation of the trenches and then filling in the trenches by the dielectric material, such as silicon oxide, by CVD. In one example, the CVD process to fill in the trenches includes high density plasma CVD (HDPCVD). In some embodiments, the formation of the STI features **112** further includes removing the hard mask after CMP. In another embodiment, the hard mask includes a silicon oxide layer by thermal oxidation and a silicon nitride on the silicon oxide layer by chemical vapor deposition (CVD).

In FIG. 1A, the active region **114** is designed to form a FET, such as a p-type FET (pFET) or an n-type FET (nFET). In some embodiments, a doped well **116** may be formed in one or more active region **114**. In some examples, the doped well **116** includes an n-type dopant, such as phosphorous (P), distributed in an active region where a pFET is to be formed. The n-type dopant may be introduced to the n-well **116** through an opening of the mask layer by a suitable doping process, such as one or more ion implantation. In some other examples, the doped well **116** includes a p-type dopant, such as boron (B), distributed in an active region where an nFET is to be formed. The p-type dopant may be introduced to the p-well **116** through an opening of the mask layer by a suitable doping process, such as one or more ion implantation. The STI features **112** further functions to define the dopants to the desired active regions. In the present example for illustration, the n-well **116** is formed in the semiconductor region **114**. In one example, the doped well **116** may have a corresponding doping concentration ranging between about 10^{16} and 10^{18} cm^{-3} . In another example, the doped well **116** may have a depth ranging between about 0.5 micrometers and 2 micrometers. A channel region **118** is defined in the active region **114** and serves as a conductive path when the corresponding FET is turned on during operations.

The semiconductor structure **100** may include more active regions. As illustrated in FIG. 1B, the semiconductor structure **100** includes a first active region **114A** and a second active region **114B**, which are separated by one STI feature **112** in some examples. The first active region **114A** is designed for an nFET to be formed thereon and the second active region **114B** is designed for a pFET to be formed thereon. In this case, a p-type doped well **116A** is formed in the first active region **114A** for the nFET and an n-type doped well **116B** is formed in the second active region **114B** for the pFET by a suitable procedure. In some examples, the procedure may include covering the first active region with a first mask (hard mask or soft mask patterned by lithography process); performing a first ion implantation to the

second active region with an n-type dopant using the first mask as implantation mask; covering the second active region with a second mask (hard mask or soft mask patterned by lithography process); and performing a second ion implantation to the first active region with a p-type dopant using the second mask as implantation mask. In the following description, one exemplary active region and one FET are usually present for simplicity. However, two exemplary active regions and two FETs are present in some figures, in order to describe different embodiments, such as a nFET and a pFET that are different in terms of composition, configuration and/or formation.

Referring to FIG. 2, a gate stack **120** is formed on the active region **114** and a channel region **118** is defined in the active region **114**. The gate stack **120** is overlying the channel region **118** and is vertically aligned with the channel region **118**. The gate stack **120** includes a gate dielectric feature **122** disposed on the semiconductor substrate **110** and a gate electrode **124** disposed on the gate dielectric feature **122**. The semiconductor structure **100** may further include gate spacers **126** disposed on sidewalls of the gate stack **120**.

The gate dielectric feature **122** includes a gate dielectric material, such as silicon oxide or a suitable dielectric material having a higher dielectric constant (high-k dielectric material). In the present embodiment, the gate dielectric feature **122** includes more than one dielectric material layers. For example, the gate dielectric feature **122** includes an interfacial dielectric layer, such as silicon oxide, and a high-k dielectric material layer on the interfacial layer.

The gate electrode **124** includes a conductive material layer, such as doped polysilicon, metal, metal alloy, metal silicide, or a combination thereof. In some embodiments, the gate electrode **124** includes more than one conductive material layers. For example, the gate electrode **124** includes a first conductive layer having a suitable work function on the gate dielectric feature **122** and a second conductive layer on the first conductive layer. In one example, the first conductive layer includes tantalum nitride or titanium nitride. In another example, the second conductive layer includes aluminum, tungsten, copper, doped polysilicon or a combination thereof.

The gate stack **120** is formed by a procedure that includes various deposition processes and patterning. The formation of the gate stack **120** is further described in accordance with some embodiments. In one embodiment, an interfacial layer is formed on the semiconductor substrate **110**. The interfacial layer may include silicon oxide formed by a proper technique, such as an atomic layer deposition (ALD), thermal oxidation or UV-Ozone Oxidation. The interfacial layer may have a thickness less than 10 angstrom. A high k dielectric material layer is formed on the interfacial layer. The high-k dielectric layer includes a dielectric material having the dielectric constant higher than that of thermal silicon oxide, about 3.9. The high k dielectric material layer is formed by a suitable process such as ALD or other suitable technique. Other methods to form the high k dielectric material layer include metal organic chemical vapor deposition (MOCVD), physical vapor deposition (PVD), UV-Ozone Oxidation or molecular beam epitaxy (MBE). In one embodiment, the high k dielectric material includes HfO₂. Alternatively, the high k dielectric material layer includes metal nitrides, metal silicates or other metal oxides. The interfacial layer and the high k dielectric material layer constitute the gate dielectric layer.

In some embodiments, the gate electrode **124** includes polysilicon. A polysilicon layer is formed on the gate dielectric layer by a proper technique, such as CVD. In one

example, a capping layer may be further formed between the high k dielectric material layer and the polysilicon layer by a proper technique, such as PVD. The capping layer may include titanium nitride (TiN), tantalum nitride (TaN) or a combination thereof in some examples. The capping layer may serve one or more functions, such as diffusion barrier, etch stop, and/or protection.

After the depositions, the gate material layers are patterned to form the gate stack **120** (or a plurality of gate stacks). The patterning of the gate stack **120** includes a lithography process and etching. A lithography process forms a patterned resist layer. In one example, the lithography process includes resist coating, soft baking, exposing, post-exposure baking (PEB), developing, and hard baking. The gate stack material layers are thereafter patterned by etching using the patterned resist layer as an etching mask. The etching process may include one or more etching steps. For example, multiple etching steps with different etchants may be applied to etch respective gate stack material layers.

In other embodiments, the patterning of the gate stack material layers may alternatively use a hard mask as an etching mask. The hard mask may include silicon nitride, silicon oxynitride, silicon oxide, other suitable material, or a combination thereof. A hard mask layer is deposited on the gate stack material layers. A patterned resist layer is formed on the hard mask layer by a lithography process. Then, the hard mask is etched through the opening of the patterned resist layer, thereby forming a patterned hard mask. The patterned resist layer may be removed thereafter using a suitable process, such as wet stripping or plasma ashing.

The gate spacers **126** include a dielectric material and may have one or more films. In some embodiments, the gate spacers **126** include silicon oxide, silicon nitride, silicon oxynitride, other suitable dielectric material, or a combination thereof. The gate spacers **126** are formed by deposition and anisotropic etch (such as dry etch).

In some embodiments, the semiconductor structure **100** may include light-doped drain (LDD) features **128** formed in the active region **114** by a suitable process, such as ion implantation. The LDD features **128** have a doping type opposite to that of the doped well **116**. For example for a pFET, the doped well **116** is n-type and the LDD features **128** are p-type. In another example for a nFET, the doped well **116** is p-type and the LDD features **128** are n-type. The LDD features **128**, the dummy gate stack and gate spacers **126** may be formed in a collective procedure. For examples, the gate stack material layers are deposited and patterned to form the dummy gate stack; the LDD features are formed by ion implantation using the dummy gate stack (and STI features) to constrain the LDD features; and then the spacers are formed. In other embodiments, the LDD features **128** are optional and may be eliminated from the semiconductor structure **100**.

Referring to FIG. 3, recesses **132** are formed in the semiconductor substrate within the active region **114** by an operation that includes etching. In some embodiments, the recesses **132** may be formed using, such as a wet (and/or dry) etch process, selectively etch the material of the substrate **110**. In furtherance of the embodiments, the gate stack **120**, the gate spacers **126**, and the STI **112** collectively function as an etching hard mask, thereby forming the recesses **132** in the source and drain regions. In some examples, an etchant such as carbon tetrafluoride (CF₄), tetramethylammonium hydroxide (THMA), other suitable etchant, or a combination thereof is used to form the recesses **132**. In some embodiments, the recesses **132** are formed with a width ranging from 50 Å and about 400 Å. A cleaning

process may follow the etching process using a suitable chemical. The recesses **132** are substantially aligned with the gate structure, particularly aligned with outer edges of the gate spacers **126**. As labeled in FIG. 3, the horizontal distance “D” is substantially zero in some examples. In some other examples, the distance “D” is greater than zero due to directionality of the etching process and/or the shadowing effect of the gate stacks **120** during the etching process. In some other examples when a wet etchant is used, lateral etch may additionally undercut the spacers **126**. In this case, the distance “D” may be less than zero or negative, which means undercut. The recesses **132** may have different geometries, such as hexagonal, depending on design and tuning of the etching process. For example, a wet etching process is substantially non-directional isotropic but the etch rate is related to the crystal orientation of a substrate surface to be etched.

In experiments, it is found that the metal residuals, such as noble metals, may present in the recesses **132**. The metal residuals may be introduced to the recesses during the operation to form the recesses **132**, such as wet etch, dry etch, and/or cleaning process. The metal residuals are identified, through our experiments and failure mode analysis, to be the root cause of defects formed in the substrate **110** during subsequent operations to fill the recesses **132**. In the present embodiments, the defects are formed through a mechanism of metal-assisted silicon etching. When chlorine is involved in the subsequent operations for filling the recesses, the metal residuals function as catalyst during chlorine-containing etching. Particularly, the silicon beneath the noble metal is etched much faster than the silicon without noble metal coverage. As a result, the noble metal sinks into the silicon substrate, generating pores or rough profile in the substrate. This will introduce defects, such as micro-porous structures to the substrate. The present disclosed method and structure are designed to address the issues.

Referring to FIG. 4A, a passivation layer **136** is formed on the recesses **132** to cover the surfaces of the recesses **132**. The passivation layer **136** is designed with composition and thickness to effectively isolate the metal residuals from the chlorine chemical during the subsequent operations. The passivation layer **136** effectively eliminates (or substantially reduces) the metal assisted silicon etching, and accordingly eliminates the formation of the associated defects. In some embodiments, the passivation layer **136** includes carbon, germanium, silicon carbide or silicon germanium. The passivation layer **136** is epitaxially grown on the surfaces of the recesses **132** and so is in crystalline structure. Thus, the subsequent operations can epitaxially grow on the passivation layer **136** and fill the recesses **132** with a semiconductor material in crystalline structure. During the formation of the passivation layer **136**, the precursor is free of chlorine (Cl) to avoid direct reaction between chlorine and the metal residuals. Since the precursor is free of chlorine, the formation of the passivation layer **136** does not involve etching and is nonselective. The passivation layer **136** may also be formed on other regions, such as on the gate stack and STI features. Those unexpected portions of the passivation layer in other regions will be removed by subsequent operations, such as deposition and etching process to fill the recesses. In some examples, the passivation layer **136** includes silicon or silicon carbide formed by a deposition with a precursor free of Cl. In some embodiments, the passivation layer **136** has a thickness ranging from about 1 nm to about 4 nm.

In one embodiment, the passivation layer **136** is a silicon carbide layer formed by a suitable process, such as CVD

process, that epitaxially grows a silicon carbide layer using a precursor free of Cl. In furtherance of the embodiment, the precursor includes monomethylsilane (CH_3SiH_3 or MMS) and silane (SiH_4). The silicon-containing chemical in the precursor may alternatively include disilane (SiH_6), trisilane (Si_3H_8), other suitable silicon-containing chemical or a combination thereof. In some examples, the precursor is free of chlorine. In the present example, the precursor is further free of dopant-containing chemical (free of phosphorous or other n-type dopant) as well. The passivation layer **136** is designed to be effective for diffusion prevention and inertness to etching. As an example for illustration, phosphorous is another issue in addition to the metal-assistant silicon etching. The phosphorous diffusion leads to the leakage and further leads to the degradation of device performance. The dopant-free precursor and corresponding dopant-free passivation layer **136** formed thereby address the above issues. In another examples, the precursor is provided with proper gas flows and partial pressures such that the epitaxially grown passivation layer **136** of SiC has a carbon concentration ranging from about 1.8% to about 3% (atomic percentage). The SiC layer with such low carbon concentration is not suitable for strain effect but is more effective as the passivation layer for isolating and preventing diffusion. In yet some examples, the passivation layer **136** is formed in both the recesses for nFET S/D regions and the recesses for pFET S/D regions, such as illustrated in FIG. 4B. In FIG. 4B, the first active region **114A** is for an nFET and the second active region **114B** is for a pFET. In some examples, the passivation layer **136** is dopant-free; has a carbon concentration ranging from about 1.8% to about 3% (atomic percentage); and is formed in formed in both the recesses for nFET S/D regions and the recesses for pFET S/D regions.

In some embodiment, the passivation layer **136** is a silicon carbide layer formed by a suitable process, such as CVD process. The SiC passivation layer **136** includes phosphorous (P) dopant with a low P doping concentration less than $1 \times 10^{20}/\text{cm}^3$, or $0 \sim 1 \times 10^{20}/\text{cm}^3$. The P dopant may be introduced by in-situ doping. During the epitaxial growth of the passivation layer **136**, the precursor further includes phosphorous-containing chemical, such as phosphine (PH_3). The P concentration in the SiC passivation layer **136** may be not enough for S/D features. S/D features of a nFET may have a P dopant concentration greater than $1 \times 10^{20}/\text{cm}^3$. The P concentration of the SiC passivation layer **136** is so tuned such that to provide a grading P concentration with smooth transition from the substrate to the S/D features and the P concentration is not too high to cause leakage concerns.

In some embodiments, the passivation layer **136** is a silicon layer formed by epitaxially growing a silicon layer using a precursor free of Cl. In furtherance of the embodiment, the precursor includes SiH_4 or other silicon-containing chemical. In the present embodiment, the precursor has no dopant (free of phosphorous and boron-containing chemical) to prevent dopant diffusion. Accordingly, the corresponding silicon passivation layer **136** is dopant-free. In some examples, the precursor during the epitaxy growth has a low partial pressure ranging from about 1 Torr to about 10 Torr.

In some embodiments, the passivation layer **136** is a silicon germanium (SiGe) layer formed by epitaxially growing a silicon germanium layer using a precursor free of Cl. In furtherance of the embodiment, the precursor includes a silicon-containing chemical (such as SiH_4) and a germanium-containing chemical (GeH_4). In the present embodiment, the precursor has no dopant (free of phosphorous and boron-containing chemical) to prevent dopant diffusion.

Accordingly, the corresponding SiGe passivation layer **136** is dopant-free (free of boron or other p-type dopant). In some examples, the SiGe passivation layer **136** has a Ge concentration ranging from about 10% to about 40% for enhanced effectiveness of the passivation layer **136**. In yet some examples, the SiGe passivation layer **136** is formed in both the recesses for nFET S/D regions and the recesses for pFET S/D regions, such as illustrated in FIG. 4B. In FIG. 4B, the first active region **114A** is for an nFET and the second active region **114B** is for a pFET. In some examples, the SiGe passivation layer **136** is dopant-free; has a germanium concentration ranging from about 10% to about 40% (atomic percentage); and is formed in formed in both the recesses for nFET S/D regions and the recesses for pFET S/D regions. In some examples, the precursor during the epitaxy growth has a low partial pressure ranging from about 1 Torr to about 10 Torr.

In some embodiments, a fluorine (F) treatment is further applied to the passivation layer **136**. Fluorine has strong interaction with silicon of the passivation layer **136** by forming F—Si bonds, thereby reducing dangling bonds. As the passivation layer is thus enhanced and certain damage to the active regions is also reduced. In some examples, the F treatment is a fluorine plasma treatment. Particularly, fluorine plasma is generated and is introduced to the passivation layer **136** in a plasma chamber. In further examples, the fluorine dose of the fluorine treatment ranges from about 1×10^{14} to about 2×10^{15} ions/ cm^2 . Accordingly, thus formed passivation layer **136** a semiconductor layer (such as Si, SiC or SiGe as described above in various embodiments) has a fluorine concentration ranging from about 1×10^{14} to about 2×10^{15} cm^{-2} . Note that the F concentration is defined as a number of fluorine atoms per unit area in the present example. In other examples, the F treatment includes applies a bias voltage ranging from 0.5 keV to about 5 keV. In some examples, the F treatment is executed in the same apparatus used to form the passivation layer **136**.

Referring to FIG. 5A, the recesses **132** are filled with a semiconductor material by a selective deposition process, thereby epitaxially growing source and drain (S/D) features **138** in crystalline structure. The deposition process to form the S/D features **138** involves chlorine for etching effect and makes the deposition selective. The selective deposition process is designed and tuned to epitaxially grow such that the S/D features **138** formed in the recesses **132** include the semiconductor material in a crystalline structure. The semiconductor material is different from that of the substrate **110**. For example, the semiconductor material includes silicon carbide or silicon germanium while the substrate **110** is a silicon substrate. In some embodiments, the semiconductor material is chosen for proper strained effect in the channel region **118** such that the corresponding carrier mobility is increased. In one example, the active region **114** is for a pFET, the semiconductor material is silicon germanium doped with boron for S/D features **138** while the substrate **110** is a silicon substrate. In another example, the active region **114** is for an nFET, the semiconductor material is silicon carbide doped with phosphorous for S/D features **138** while the substrate **110** is a silicon substrate.

This is further illustrated in FIG. 5B in accordance with some embodiments. The semiconductor structure **100** includes the first active regions **114A** for a nFET and the second active region **114B** for a pFET. The semiconductor structure **100** further includes the p-type doped well **116A** in the first active region **114A** and the n-type doped well **116B** in the second active region **114B** for the pFET. The semiconductor structure **100** further includes the first gate stack

120A and the second gate stack 120B, disposed within the first and second active regions, respectively. Particularly, the S/D features 138A are silicon carbide doped with phosphorous (SiC—P), providing tensile stress to the channel region 118A of the nFET, according to one embodiment. In another embodiment, the S/D features 138B are silicon germanium doped with boron (SiGe—B), providing compressive stress to the channel region 118B of the pFET. In some other embodiments, the S/D features 138A of SiC—P and the S/D features 138B of SiGe—P are both present in the semiconductor structure 100 and are formed respectively by a suitable procedure. In one example, the procedure includes covering the first active region 114A using a first mask while epitaxially growing SiGe—B in the recesses of the second active region 114B and covering the second active region 114B using a second mask while epitaxially growing SiC—P in the recesses of the first active region 114A. The first and second masks may be patterned resist layers formed by lithography or alternatively hard masks formed by deposition and lithography patterning. In yet other embodiments, the S/D features 138A are SiC—P while the S/D features 138B are silicon doped with boron (Si—B) or the S/D features 138A are silicon doped with phosphorous (Si—P) while the S/D features 138B are SiGe—B.

Still referring to FIG. 5B, while the S/D features 138A and 138B are different as described above, the passivation layer 136 is same to both active regions 114A and 114B in terms of composition and formation, in accordance with some embodiments, such as those in FIG. 4B. In one example, the passivation layer 136 includes a phosphorous-free SiC layer with a carbon concentration ranging from about 1.8% to about 3%. In furtherance of the example, the S/D features 138A include SiC—P (or Si—P) while the S/D features 138B may include SiGe—B (or Si—B). In another example, the passivation layer 136 includes a SiC—P layer with a phosphorous concentration less than $10^{-20}/\text{cm}^3$ and the S/D features 138A include SiC—P with a phosphorous concentration greater than $10^{-20}/\text{cm}^3$. In yet another example, the passivation layer 136 is a SiGe layer free of boron or other p-type dopant.

Still referring to FIG. 5B, the first gate electrode 124A and the second gate electrode 124B may be same in composition (such as polysilicon) or alternatively different (such as the first gate electrode 124A includes a n-type work function metal layer and the second gate electrode 124B includes a p-type work function metal layer), such as in a gate-first process to form metal gates.

The operation to form the S/D features is further described according to various embodiments. In some embodiments, the selective deposition process to form the S/D features 138 in the recesses 132 is a cyclic deposition and etching (CDE) process. The semiconductor material is epitaxially grown in the recesses 132. In the present embodiment, the S/D features 138 are in-situ doped during the CDE process with precursor that includes dopant-containing chemical. The CDE process is a two-cycle operation with a precursor having chlorine for deposition/etching effects so that the semiconductor material is selectively deposited in the recesses 132. In the first cycle (deposition cycle), the various chemicals are used as precursor to epitaxially grow the semiconductor material. In the second cycle (etching cycle), chlorine-containing gas (such as HCl, Cl₂ or both) is used for etching. The CDE process repeats the two cycles until the recesses 132 are filled or alternatively overgrowing beyond the top surface of the substrate 110.

In some embodiments when an nFET is formed in the active region 114 in FIG. 5A (or 114A in FIG. 5B), the

semiconductor material is silicon carbide with phosphorous (P) dopant. In furtherance of the embodiments, the precursor used in the first cycle (deposition cycle) of the CDE process includes SiH₄ (and/or Si₂H₆), PH₃, and MMS. The second cycle (etching cycle) includes HCl or Cl₂. In one example, the HCl is provided with a processing chamber pressure ranging from about 200 Torr to about 250 Torr.

In some other embodiments when a pFET is formed in the active region 114 in FIG. 5 (or 114B in FIG. 5B), the semiconductor material is silicon germanium with boron (B) dopant. In furtherance of the embodiments, the precursor used in the first cycle (deposition cycle) of the CDE process includes SiH₄ (and/or Si₂H₆), B₂H₆, and GeH₄. The second cycle (etching cycle) includes HCl or Cl₂. In one example, the HCl is provided with a processing chamber pressure ranging from about 200 Torr to about 250 Torr.

In some embodiments, the precursor used in the deposition cycle may alternatively includes other silicon-containing chemical, such as silane (SiH₄), disilane (Si₂H₆), trisilane (Si₃H₈), dichlorosilane (SiH₂Cl₂), another silicon-containing precursor, or a combination thereof.

In some embodiments, the operation to form the S/D features 138 may alternatively use other deposition technique, such as a deposition process that the deposition gas (chemicals for deposition) and etching gas (chlorine-containing gas, such as Cl₂ or HCl) are simultaneously flown to the processing chamber. Instead of two cycles, the operation is a continuous deposition/etching process that epitaxially grows the semiconductor material selectively in the recesses 132. Thus, the disclosed deposition of the semiconductor material to the recesses 132 is insensitive to the metal residuals, eliminating the metal assisted silicon etching issue and the associated defects. The deposition process is referred to as selective epitaxy growth (SEG) with co-flow deposition & etches chemicals, or simply referred to as co-flow epitaxy growth (or co-flow epitaxy deposition).

In some embodiments, the S/D features may be formed by a combination of CDE and co-flow epitaxy growth. The S/D features 138A may include SiC—P with graded phosphorous concentration formed by two or more steps of CDE and co-flow epitaxy growth. For example, the the S/D features 138A includes first SiC—P layer; a second SiC—P layer on the first SiC—P layer; and a third SiC—P layer on the second SiC—P layer with respective dopant concentrations. In a particular example, the S/D features 138A include the first SiC—P layer with a first phosphorous concentration ranging from about $10^{20}/\text{cm}^3$ to about $4 \times 10^{20}/\text{cm}^3$ formed by a CDE process with in-situ doping; the second SiC—P layer with a second phosphorous concentration ranging from about $4 \times 10^{20}/\text{cm}^3$ to about $10^{21}/\text{cm}^3$ formed by a co-flow epitaxy growth with in-situ doping; and the third SiC—P layer with a third phosphorous concentration ranging from about $10^{21}/\text{cm}^3$ to about $3 \times 10^{21}/\text{cm}^3$ formed by another co-flow epitaxy growth with in-situ doping. In furtherance of the example, the first, second and third SiC—P layers have thicknesses 10 nm~20 nm; 10 nm~20 nm; and 5 nm 15 nm, respectively.

In some embodiments, the S/D features 138 are formed in the recesses 132 such that the recesses 132 are substantially filled with a top surface substantially coplanar to the substrate 110 (particularly, coplanar with the top surface of the channel region 118, such as illustrated in FIG. 5A or FIG. 5B). The S/D features 138 may have other alternatives in terms of composition, geometry and formation. As illustrated in FIG. 6, the S/D features 138 are over grown in the recesses 132 beyond the top surface of the channel region 118.

11

The semiconductor structure **100** may include other features formed by corresponding operations. In one embodiment, an interlayer dielectric (ILD) layer is formed by a deposition technique, such as chemical vapor deposition CVD and CMP. In another embodiment, an interconnect structure is formed and include various conductive features (such as metal lines, contact features and via features) configured to couple various devices to form a functional circuit.

In other embodiments, the gate stack **120** is a dummy gate and is replaced by a gate stack having metal electrode and high-k dielectric in a gate replacement procedure, such as a gate-last process or a high-k last process. In a gate-last process, an interlayer dielectric (ILD) material layer is formed on the substrate and surrounding the gate stack **120**, by deposition and polishing (e.g., CMP). The gate electrode in the dummy gate is removed by selective etching, resulting in a gate trench in the ILD. Thereafter, a final gate stack is formed in the gate trench of the ILD by a suitable procedure, such as deposition and CMP. A high-k-last process is similar to the gate-last process but the gate dielectric of the dummy gate is treated differently. In the high-k-last process, the dummy gate stack (including both gate dielectric and gate electrode) is removed after the ILD formation. Thereafter, a final gate stack is formed in the gate trench of the ILD.

One embodiment of the gate replacement is provided in FIGS. **7** and **8A** for illustration. An ILD layer **142** is formed on the substrate **110** and surrounding the dummy gate stack **120**, by deposition and polishing (e.g., CMP). The ILD material layer **142** includes one or more dielectric materials, such as silicon oxide, fluorinated silica glass (FSG), low-k dielectric material or other suitable dielectric material. The deposition may include CVD or plasma-enhanced CVD or other suitable deposition technique. The dummy gate stack **120** is removed by selective etching, resulting in a gate trench **144** in the ILD material layer **142**. Thereafter, a gate stack **146** of high k dielectric and metal electrode is formed in the gate trench **144** by a suitable procedure that includes deposition and CMP. Thus formed gate **146** includes gate dielectric **148** and metal gate electrode **150**. In a particular example, the gate dielectric **148** includes an interfacial layer of silicon oxide and a high-k dielectric layer on the interfacial layer.

The metal gate electrode **150** includes a metal layer **152** has a proper work function (a metal with a work function less than about 4.2 eV for nFET or greater than about 5.2 eV for pFET), such as tantalum for nFET and titanium nitride for pFET. The metal layer **152** is also referred to as work function (WF) layer, or particularly n-type WF layer or p-type WF layer. The gate electrode **150** may include multiple conductive layers. For example, the gate electrode **150** includes the WF layer **152** on the gate dielectric feature **148** and a conductive layer **154** on the WF layer **152**. In one example, the WF layer **152** includes tantalum or titanium nitride. In another example, the conductive layer **154** includes aluminum, tungsten, copper, doped polysilicon or a combination thereof. When the gate stack **146** is formed by a high-k last process, the gate dielectric layer **148** is formed on bottom and sidewalls of the gate trench **144**, or is U-shaped in other words.

Thus formed semiconductor structure **100** includes a gate stack, epitaxially grown S/D features of a semiconductor material different from that of the substrate; and a passivation layer disposed surrounding the S/D features and separating the S/D features from the substrate. The passivation layer effectively prevents the metal residual from direct contact with the Cl-containing chemical during the opera-

12

tions to form the S/D features, thereby eliminating the defects associated with the interaction between Cl and the metal residuals.

FIG. **8B** illustrates a sectional view of the semiconductor structure **100** that includes a first FET of a first conductivity and a second FET of second conductivity opposite to the first conductivity. The first conductivity is one of a n-type conductivity and a p-type conductivity and the second conductivity is another one. For example, the first and second FETs are nFET and pFET, respectively. The semiconductor structure **100** in FIG. **8B** includes a first metal gate stack **146A** disposed on the first active region **114A** for nFET and a second metal gate stack **146B** disposed on the second active region **114B** for pFET. The first metal gate stack **146A** and the second metal gate stack **146B** are both metal gate stacks formed by high-k last process. In the present embodiment, the first metal gate stack **146A** and the second metal gate stack **146B** are different from each other in composition. Particularly, the first metal gate stack **146A** includes a n-type WF layer **152A** having a work function less than about 4.2 eV (such tantalum) and a p-type WF layer **152B** having a work function greater than about 5.2 eV (such as tantalum nitride). In one example of a procedure to form the metal gate stacks, the first gate stack **146A** is formed within the first active region **114A** while the second active region **114B** is covered by a mask (such as a patterned resist layer or a patterned hard mask layer), and the second gate stack **146B** is formed within the second active region **114B** while the first active region **114A** is covered by another mask.

FIG. **9** illustrates a sectional view of the semiconductor structure **100** in accordance with other embodiments. The semiconductor structure **100** in FIG. **9** is similar to that in FIG. **8A** except for that the metal gate stack **146** is formed by a gate last process. Particularly, the gate dielectric layer **120** is formed before the formation of the ILD layer **142** and therefore is not formed on the sidewalls of the gate trench **144**.

As noted above, the described semiconductor structure **100** may be formed on a planar substrate or alternatively on a non-planar substrate, such as a substrate having fin-like active region(s). FIGS. **10-12** illustrate the semiconductor structure **160** having fin-like active regions, constructed according to various aspects of the present disclosure in some embodiments. FIG. **10** is a top view of the semiconductor structure **160**. FIG. **11** is a sectional view of the semiconductor structure **160** along the dashed line AA' and FIG. **12** is a sectional view of the semiconductor structure **160** along the dashed line BB'. The semiconductor structure **160** includes a first fin-like active region **114** and a second fin-like active region **162** separated isolation features **112**, such as STI features. The semiconductor structure **160** further includes a gate stack **146** formed over the first and second fin-like active regions.

For a fin-like active region, the top surface **164** of the semiconductor substrate **110** (specifically the top surface of the channel region **118**) and the top surfaces **168** of the STI features **112** are not coplanar, resulting in a three-dimensional structure. A FET formed on a fin-like active region is also referred to as a fin FET (FinFET). As illustrated in FIG. **11**, the active region **114** is extruded above the top surface **168** of the STI features **112**. The fin-like active regions are formed by a suitable technique, such as etching or epitaxy growth. In one example, after the formation of STI features **112**, an etching process, such as wet etching, is applied to selectively etch the STI such that the STI features **112** are recessed. In another example, after the formation of STI

13

features **112**, a selective epitaxy growth process is applied to epitaxially grow a semiconductor material on the semiconductor substrate **110** such that the active region **114** is extended vertically above the top surface of the STI features **112**. The semiconductor material of the fin active regions may be same to that of the semiconductor substrate, such as silicon, or alternatively different from that of the semiconductor substrate, such as silicon germanium. As illustrated in FIG. **12**, the second fin active region **162** includes a doped well **170** and a channel region **172** formed in the doped well channel region. The gate stack **146** includes gate dielectric **148** and a gate electrode **150** formed by any proper procedure, such as gate-last process or high-k last process. Even though the fin-like active regions are illustrated in FIGS. **10-12**, various embodiments of the semiconductor structure **100** illustrated in FIG. **1A** through **9** may also embrace a fin structure having fin-like active region(s) and FinFET(s).

FIG. **13** is a flowchart of a method **200** to form a semiconductor structure (such as **100** or **160**) constructed according to various aspects of the present disclosure in some embodiments. The method **200** is described with reference to FIG. **8** and other figures. However, the semiconductor structure **100** is provided as an example and is not intended to limit the scope of the method. The method **200** includes a block **202** by providing a semiconductor substrate **110**, such as a silicon wafer. The semiconductor substrate **110** may further include other features/components, such as doped well **116** and STI **112**.

The method **200** also includes an operation **204** to form gate stack **120**. The formation of the gate stack includes various depositions and patterning. Other features, such as gate spacers **126** and LDD features **128** may be further formed.

The method **200** includes an operation **206** by forming recesses **132**. The recesses **132** are formed in the semiconductor substrate within the active region **114** by an operation that includes etching. In some embodiments, the recesses **132** may be formed using, such as a wet (and/or dry) etch process selective to the material of the substrate **110**. A cleaning process may follow the etching process using a suitable chemical. The etching and/or cleaning processes may introduce metal residuals to the recesses **132**.

The method **200** includes an operation **208** by forming a passivation layer **136**. The passivation material layer **136** is formed to cover the substrate **110** and is designed with composition and thickness to effectively isolate the metal residuals from the chlorine chemical during the subsequent operations, thereby eliminating the metal assisted silicon etching and eliminating the formation of the associated defects. In some embodiments, the passivation layer **136** includes carbon, germanium, silicon carbide or silicon germanium, such as those described in FIG. **4A**. The passivation layer **136** is epitaxially grown on the substrate **110** and is formed by a non-selective epitaxy growth using a chlorine-free precursor. Note that the passivation layer **136** may be formed on other regions (such as on STI features and/or on gate stack) with non-crystalline structure but those portions of the passivation layer **136** will eventually be removed, such as during the next operation **210**. Thus, the passivation layer **136** within the recesses **132** is in crystalline structure so that the subsequent operations can epitaxially grow and fill the recesses **132** to form S/D features in crystalline structure. During the formation of the passivation layer **136**, the precursor is free of chlorine (Cl) to avoid direct reaction between Cl and the metal residuals. Since the precursor is free of Cl, the deposition is nonselective and may also be formed on other regions, such as on the gate

14

stack and STI features. In some examples, the passivation layer **136** includes silicon or silicon carbide formed by a deposition with precursor free of Cl. In some embodiments, the passivation layer **136** has a thickness ranging from about 1 nm to about 4 nm.

In one embodiment, the passivation layer **136** is a silicon carbide layer formed by epitaxially growing a silicon carbide layer using a precursor free of Cl. In furtherance of the embodiment, the precursor includes monomethylsilane (CH_3SiH_3 or MMS) and SiH_4 . The passivation layer **136** may include a mono layer or multiple layers. In the present example, the precursor is further free of dopant (such as free of phosphorous) to prevent dopant diffusion. In this case, the passivation layer **136** is free of chlorine and dopant. In some embodiments, the precursor is tuned (by controlling gas flows for examples) to form a SiC layer.

In alternative embodiment, the passivation layer **136** is a silicon layer formed by epitaxially growing a silicon layer using a precursor free of Cl. In furtherance of the embodiment, the precursor includes SiH_4 . The passivation layer may include a mono layer or multiple layers. In the present embodiment, the precursor includes no dopant (such as phosphorous or boron-containing chemical) to prevent dopant diffusion. In some other embodiments, the passivation layer **136** may include is a germanium layer or a silicon germanium layer.

The method **200** includes an operation **210** to form S/D feature **138** by epitaxial growing in the recesses **132** with a semiconductor material different from that of the substrate **110** for strain effect. The operation **210** involves chlorine for etching effect and therefore is selective. The deposition occurs on the substrate **110** and also on other regions (such as STI and gate stacks) with different deposition rates and structures. The chlorine-containing gas provides etching effect such that the semiconductor material deposited on the other regions (such as on STI features and/or gate stack) is completely removed, making the operation **210** a selective deposition. The semiconductor material deposited in the recesses **132** is crystalline since the passivation layer **136** is crystalline and serves as a seed layer for epitaxy growth.

In some embodiments, the operation **210** includes a CDE process. The recesses **132** are filled with the semiconductor material by a CDE process, thereby forming S/D features **138**. The semiconductor material is different from that of the substrate **110**. For example, the semiconductor material includes silicon carbide or silicon germanium while the substrate **110** is a silicon substrate. In the present embodiment, the source and drain features **138** are in-situ doped during the CDE process during the CDE process with precursor that includes dopant-containing chemical. The CDE process is a two cycle operation. In the first cycle for deposition, various chemicals are used as precursor to epitaxially grow the semiconductor material. In the second cycle, a chlorine-containing gas (such as HCl, Cl_2 or both) is used for etching. The CDE process repeats the two cycles until the recesses **132** are filled or alternatively overgrowing beyond the top surface of the substrate **110**.

In some embodiments when an nFET is formed in the active region **114**, the semiconductor material is silicon carbide with phosphorous (P) dopant. In furtherance of the embodiments, the precursor used in the first cycle (deposition cycle) of the CDE process includes SiH_4 (and/or Si_2H_6), PH_3 , and MMS. The second cycle (etching cycle) includes HCl or Cl_2 . In one example, the HCl is provided with a processing chamber pressure ranging from about 200 Torr to about 250 Torr.

In some other embodiments when a pFET is formed in the active region **114**, the semiconductor material is silicon germanium with boron (B) dopant. In furtherance of the embodiments, the precursor used in the first cycle (deposition cycle) of the CDE process includes SiH₄ (and/or Si₂H₆), B₂H₆, and GeH₄. The second cycle (etching cycle) includes HCl or Cl₂. In one example, the HCl is provided with a processing chamber pressure ranging from about 200 Torr to about 250 Torr.

In some embodiments, the precursor used in the deposition cycle includes silane, disilane, trisilane, Dichlorosilane (SiH₂Cl₂), another silicon-containing precursor, and/or any combinations thereof.

In some embodiments, the operation **210** may use a co-low deposition process. In the co-flow epitaxy growth, the chemicals for deposition and chlorine-containing gas are simultaneously flown to the processing chamber for continuous and simultaneous deposition/etching effect. The chemicals for deposition and the chlorine-containing gas are similar to those used in the CDE process.

Other fabrication steps may be implemented before, during and after the operations of the method. In one embodiment, an inter-level dielectric (ILD) layer is formed on the semiconductor substrate. The ILD layer includes silicon oxide, low k dielectric material, other suitable dielectric materials, or combinations thereof. The ILD layer is formed by a suitable technique, such as CVD. For example, high density plasma CVD may be implemented to form the ILD layer.

In another embodiment, the method further includes a procedure to form various interconnection features designed to couple various devices to form a functional circuit. The interconnection features include vertical interconnects, such as contacts and vias, and horizontal interconnects, such as metal lines. The various interconnection features may use various conductive materials including copper, tungsten and silicide. In one example, a damascene process is used to form copper-based multilayer interconnection structure. In another embodiment, tungsten is used to form tungsten plug in the contact holes. In another example, silicide is used to form various contact on source and drain regions for reduced contact resistance.

FIG. **14** is a flowchart of a method **220** to form a semiconductor structure constructed according to various aspects of the present disclosure in some other embodiments. The method **220** is similar to the method **200**. However, the method **220** further includes an operation **222** implemented between the operations **208** and **210**. The operation **222** includes applying a fluorine treatment process to the passivation layer **136**. In some embodiments, the F treatment is a fluorine plasma treatment. Particularly, fluorine plasma is generated in a plasma chamber and is introduced to the passivation layer **136**. In further examples, the fluorine dose of the fluorine treatment ranges from about 1×10^{14} to 2×10^{15} ions/cm². Accordingly, thus formed passivation layer **136** a semiconductor layer (such as Si, SiC or SiGe as described above in various embodiments) has a fluorine concentration ranging from about 1×10^{14} to 2×10^{15} cm⁻². In other examples, the F treatment includes applies a bias voltage ranging from 0.5 keV to about 5 keV. In some examples, the F treatment is executed in the same apparatus used to form the passivation layer **136**. Fluorine has a strong interaction with silicon and forms F—Si bonds, reduces the dangling bonds, and therefore reducing/eliminating subsequent damages to the substrate, particularly the portions underlying the passivation layer **136**. After the F treatment

to the passivation layer **136**, the method **220** proceeds to the operation **210** by epitaxially growing a semiconductor material in the recesses **132**.

FIG. **15** is a flowchart of a method **230** to form a semiconductor structure constructed according to various aspects of the present disclosure in some other embodiments. The method **230** is designed to form epitaxy grown S/D features while the metal assisted silicon etching effect and the associated defects are eliminated or substantially reduced. The method **230** includes blocks **202-206** similar to those of the method **200**.

After the formation of the recesses **132** in the substrate **110** by the operation **206**, the method **230** proceeds to an operation **232** to form the S/D features **138** in the recesses **132**. The operation **232** includes an epitaxy deposition with a varying etching/deposition factor. Particularly, the operation **232** epitaxially grows a semiconductor material in the recesses **132** with both deposition and etching effects. During the operation **232**, a chlorine-containing gas (such as Cl₂ or HCl) is introduced into the processing chamber for etching effect, thus making the epitaxy deposition selective (selectively growing on a substrate **110**). In various embodiments, the operation **232** includes a CDE process, a co-flow epitaxy growth, or a combination thereof. Various aspects of the CDE and co-flow epitaxy growth are described above and are not repeated here. An etching/deposition (E/D) factor is introduced and defined to characterize the epitaxy deposition **232**. The E/D factor is defined as a ratio of the etch amount over the deposition amount to the semiconductor substrate during a certain process time. The E/D factor ranges from 0 to a value less than 1. The epitaxy deposition **232** is implemented in a way such that the E/D factor varies over the epitaxy deposition process, particularly increases over the process. The epitaxy deposition **232** and the E/D factor are further described below in accordance with some embodiments.

As described above with the method **200**, a CDE process includes a deposition cycle (or D cycle) and an etching cycle (or E cycle) repeated multiple times. The E/D factor is variable by varying one or more parameters, such as processing temperature, gas flow, gas partial pressure, E cycle duration, D cycle duration, a ratio of E cycles over D cycles, or a combination thereof. In one embodiment, the duration of D cycle and the duration of E cycles (or a ratio of D duration over E duration) are tuned to vary the E/D factor. As an example for illustration, a CDE process may have 15 second deposition and then 10 second etching for one E/D factor, or have 10 second deposition and then 6 second etching for another E/D factor. In another embodiment, the number of E cycles and the number D cycles (or a ratio of E cycles over D cycles) are tuned to vary the E/D factor. As an example for illustration, a CDE process may have 2 deposition cycles and 1 etching cycle for one E/D factor, or have 1 deposition cycle and 1 etching cycle for another E/D factor. In another embodiment, the substrate temperature is varied to vary the E/D factor. In an example for illustration, during an etching cycle of the CDE process, the substrate temperature is decreased to reduce the etching effect, therefore decreasing the E/D factor. In another embodiment, the E/D factor is tuned by reducing the deposition gas pressure (or deposition gas flow rate) to increase the E/D factor. In yet another embodiment, the E/D factor is tuned by reducing the etching gas pressure (or etching gas flow rate) to decrease the E/D factor.

In a co-flow epitaxy growth, the E/D factor is varied similarly. In one embodiment, the substrate temperature is varied to vary the E/D factor. For example, the etching effect

is apparent only when the substrate temperature is at or greater than 620 C. When the substrate temperature is increased to above 620 C, thereby increasing the etching effect, therefore increasing the E/D factor. In another embodiment, the E/D factor is tuned by reducing the deposition gas partial pressure (or deposition gas flow rate) to increase the E/D factor. In yet another embodiment, the E/D factor is tuned by reducing the etching gas partial pressure (or etching gas flow rate) to decrease the E/D factor.

In the operation **210** of the method **200**, the E/D factor in the corresponding CDE process or co-flow epitaxy growth is a constant over the process. In the operation **232**, the E/D factor is a varying parameter that increases over the process. Initially, the E/D factor is less enough such that the metal assisted silicon etching is eliminated or substantially reduced. Then, the E/D factor is increased over the process time, thereby making the epitaxy process **232** selective.

In some embodiments, the epitaxy deposition process in the operation **232** includes a first deposition step **234** having a first E/D factor and a second deposition step **236** having a second E/D factor. It is further illustrated in FIG. **15**. At the first deposition step **234**, the epitaxy deposition process is controlled to have the first E/D factor **242** that is chosen to substantially reduce the chlorine and reduces the interaction between the chlorine and the metal residuals. The first E/D factor **242** ranges from zero to about 0.2 in some examples. The first deposition step **234** is not selective. At the second deposition step **236**, the second E/D factor **244** is tuned such that the epitaxy deposition process selectively deposits on the substrate **110**. The second E/D factor **244** is greater than the first E/D factor **242**. The second E/D factor **244** ranges from about 0.2 to about 0.5 in some examples. Note the deposition at the first deposition step **234** is not selective or has no enough selectivity. Any unexpected deposition to other regions (such as STI features and gate stack) during the first deposition step will be removed during the second deposition step due to the increased etching effect.

In the operation **232**, the corresponding deposition technique may be a CDE process, co-flow epitaxy growth or a combination. In some other embodiments, as long as the two deposition steps are tuned to address the metal related defects and deposition selectivity, the deposition gas (not etching gas) may include chlorinated chemical. For example, the SiH_2Cl_2 may be used as a silicon-containing gas in the operation **232**.

In some examples, the epitaxy deposition process **232** is a CDE process. The first deposition step **234** has a HCl (or Cl_2) partial pressure less than 100 Torr for the etch cycle(s) while the second deposition step **236** has a HCl (or Cl_2) partial pressure greater than 100 Torr for the etch cycle(s). In some other examples, the epitaxy deposition process **232** is a co-flow epitaxy epitaxy growth. The first deposition step **234** has a HCl (or Cl_2) partial pressure less than 3 Torr while the second deposition step **236** has a HCl (or Cl_2) partial pressure greater than 3 Torr.

In some other examples, the epitaxy deposition process **232** is a co-flow epitaxy growth (or a CDE process). The E/D factor is tuned by the substrate temperature. As noted above, the etch effect is apparent when the substrate temperature is greater than 620 C. The first deposition step **234** has a first substrate temperature less than about 620 C and the second deposition step **236** has a second substrate temperature greater than 620 C.

In some other embodiments, the operation **232** uses a co-flow epitaxy growth that with two steps: a first deposition step **234** with a first E/D factor and a second deposition step **236** with a second E/D factor greater than the first E/D

factor. During the co-flow epitaxy growth, the deposition gas and etching gas are dynamically controlled, such as by controlling gas flow rates, to dynamically change the E/D factor with considerations similar to those described with the CDE process. For example, the etching gas flow rate is initially zero or lower. Then the etch gas flow rate increases over processing time. At the first deposition step **234**, the chlorine (e.g., HCl) gas partial pressure in the processing chamber is low, such as ranging from about 1 Torr to about 10 Torr in some examples. At the second deposition step **236**, the chlorine gas partial pressure in the processing chamber is greater than that of the first deposition step **225**, such as ranging from about 200 Torr to about 250 Torr in some examples.

In some other embodiments, the epitaxy deposition process **232** is designed such that the E/D factor has a step-wise variation over the process. As illustrated in FIG. **17**, the E/D factor **246** is step-wise over the process time. Again, the variation of the E/D factor may be implemented through one or more mechanisms, such as gas flow, gas partial pressure, and substrate temperature. The deposition mechanism may be CDE, co-flow epitaxy growth or a combination.

In some embodiments, the operation **232** is designed such that the E/D factor varies continuously over the process. The E/D factor varies in a range from 0 to 1. During the operation **232**, the E/D factor dynamically changes for various considerations that include the deposition selectivity, the metal assisted silicon etching issues and/or deposition quality. Initially, the metal assisted silicon etching issues is the prime concern, so the E/D factor is chosen to be lower. At the later stage of the operation **232**, the deposition selectivity is a dominant while the metal assisted silicon etching issue is subordinate. Therefore, the E/D factor is increased. The E/D factor may be a proper function of the process time, such as a linear function or a non-linear function. Illustrated in FIG. **18** is an example that the E/D factor **248** is a linear function of the process time. Illustrated in FIG. **19** is another example that the E/D factor **250** is a non-linear function of the process time. It may be tuned and optimized for better fabrication result in consideration of various factors, such as the semiconductor material to be deposited, processing throughput, and device tolerance range to the defects associated with the metal assisted silicon etching effect.

Other fabrication steps may be implemented before, during and after the operations of the method. In one embodiment, an inter-level dielectric (ILD) layer is formed on the semiconductor substrate. The ILD layer includes silicon oxide, low k dielectric material, other suitable dielectric materials, or combinations thereof. The ILD layer is formed by a suitable technique, such as CVD. For example, high density plasma CVD may be implemented to form the ILD layer. In another embodiment, a gate replacement procedure may be implemented to form a final gate stack having high k dielectric and metal gate electrode. In another embodiment, the method further includes a procedure to form various interconnection features designed to couple various devices to form a functional circuit.

The present disclosure provides a method and structure of a FET that addressing the defect issue associated with the metal residuals and chlorine. The method includes forming a passivation layer in the recesses of the semiconductor substrate before epitaxially growing a semiconductor material to form S/D features in the recesses. The passivation layer is designed with composition, thickness and configuration to effectively prevent the interaction between Cl-containing chemical and the metal residual in the recesses. In other embodiments, a fluorine treatment is further applied

19

to the passivation layer to enhance its effectiveness. In other embodiments, the method implements a deposition method to epitaxially growing S/D features with a varying E/D factor. The E/D factor varies over the processing time to address the defect issue associated with the metal residuals and chlorine. The E/D factor is chosen to be lower initially to address the defect issue, and then is increased over time to enhance the deposition selectivity.

The semiconductor structure **100** may be used in various applications, such as logic circuit, dynamic random access memory (DRAM), static random access memory (SRAM) cells, flash memory, or imaging sensor. The semiconductor structure is a planar FET structure or alternatively a FinFET structure. In other embodiments, the disclosed method to selectively deposit a semiconductor material layer may be used to form other epitaxy features with substantially reduced metal sensitivity during the process. In one example for a FET with epitaxy grown channel region, the method is described below: the dummy gate is removed to form a gate trench; the substrate is recessed within the gate trench; epitaxially growing a semiconductor material in the recessed region by the disclosed deposition method.

The present disclosure provides a method forming a field effect transistor (FET) in accordance with some embodiments. The method includes performing an etching process to a semiconductor substrate, thereby forming recesses in source and drain (S/D) regions of the semiconductor substrate; forming a passivation material layer of a first semiconductor in the recesses; and epitaxially growing a second semiconductor material, thereby forming S/D features in the recesses, wherein the S/D features are separated from the semiconductor substrate by the passivation material layer.

The present disclosure provides a method forming a field effect transistor (FET) in accordance with some other embodiments. The method includes performing an etching process to a semiconductor substrate, thereby forming recesses in source and drain (S/D) regions of the semiconductor substrate; and epitaxially growing a semiconductor material by a deposition process with a varying etching/deposition (E/D) factor, thereby forming S/D features in the recesses.

The present disclosure provides an integrated circuit structure in accordance with some embodiments. The integrated circuit structure includes a semiconductor substrate of a first semiconductor material and having first recesses; a first gate stack formed on the semiconductor substrate and being adjacent the first recesses; a passivation material layer of a second semiconductor material and formed in the first recesses; and first source and drain (S/D) features of a third semiconductor material and formed in the first recesses and being separated from the semiconductor substrate by the passivation material layer, wherein the passivation material layer is free of chlorine.

The foregoing has outlined features of several embodiments. Those skilled in the art should appreciate that they may readily use the present disclosure as a basis for designing or modifying other processes and structures for carrying out the same purposes and/or achieving the same advantages of the embodiments introduced herein. Those skilled in the art should also realize that such equivalent constructions do not depart from the spirit and scope of the present disclosure, and that they may make various changes, substitutions and alterations herein without departing from the spirit and scope of the present disclosure.

What is claimed is:

1. A method of forming a field effect transistor (FET), the method comprising:

20

performing an etching process to a semiconductor substrate, thereby forming recesses in source and drain (S/D) regions of the semiconductor substrate;

forming, by a non-selective deposition process, a passivation material layer of a first semiconductor material in the recesses; and

epitaxially growing a second semiconductor material on the passivation material layer, thereby forming S/D features in the recesses, wherein the S/D features are separated from the semiconductor substrate by the passivation material layer, wherein the first semiconductor material is different than the second semiconductor material, wherein the epitaxially growing of the second semiconductor material includes performing a cyclic deposition and etching (CDE) process having a first deposition step and a second deposition step, and wherein the first deposition step and the second deposition step are performed at different temperatures.

2. The method of claim **1**, wherein the forming of the passivation material layer includes performing the non-selective deposition process using a precursor free of chlorine.

3. The method of claim **2**, wherein the forming of the passivation material layer includes epitaxially growing the passivation material layer of the first semiconductor material.

4. The method of claim **3**, wherein the first semiconductor material includes silicon carbide and the second semiconductor material includes silicon germanium.

5. The method of claim **3**, wherein the forming of the passivation material layer includes epitaxially growing the passivation material layer of the first semiconductor material that is free of dopant, using the precursor free of dopant-containing gas.

6. The method of claim **3**, wherein the forming of the passivation material layer includes forming a silicon carbide layer having a carbon atomic percentage ranging from 1.8% to 3%.

7. The method of claim **1**, wherein the forming of the passivation material layer includes forming the passivation material layer with a thickness ranging from 1 nm to 4 nm, effectively preventing interaction between chlorine and metal residuals under the passivation material layer.

8. The method of claim **1**, further comprising performing a fluorine treatment to the passivation material layer before the epitaxially growing of the second semiconductor material.

9. The method of claim **8**, wherein the performing of the fluorine treatment includes performing the fluorine treatment with a fluorine dose ranging from 1×10^{14} ions/cm² to 2×10^{15} ions/cm².

10. The method of claim **1**, wherein the epitaxially growing of the second semiconductor material includes epitaxially growing the second semiconductor material with in-situ doping one of a n-type dopant and a p-type dopant.

11. The method of claim **1**, wherein

the CDE process includes a first cycle for deposition and a second cycle for etching; and

the second cycle uses a chlorine-containing gas that includes at least one of HCl and Cl₂.

12. The method of claim **11**, wherein the first cycle of the CDE process uses a precursor that includes PH₃, monomethylsilane (MMS), and at least one of SiH₄ and Si₂H₆.

13. The method of claim **11**, wherein the first cycle of the CDE process uses a precursor that includes B₂H₆, GeH₄, and at least one of SiH₄ and Si₂H₆.

21

14. The method of claim 1, wherein the passivation material layer is formed by the non-selective deposition process using a precursor that includes monomethylsilane (MMS) and at least one of silane (SiH₄) and disilane (SiH₆).

15. The method of claim 1, further comprising:
 prior to epitaxially growing the second semiconductor material, doping the passivation layer with fluorine atoms to form a fluorine-doped passivation layer; and epitaxially growing a second semiconductor material on the fluorine-doped passivation material layer.

16. A method of forming a field effect transistor (FET), the method comprising:

performing an etching process to a semiconductor substrate, thereby forming recesses in source and drain (S/D) regions of the semiconductor substrate; and epitaxially growing a semiconductor material by a deposition process with a varying etching/deposition (E/D) factor, thereby forming S/D features in the recesses, wherein the deposition process includes a co-flow epitaxy growth, wherein the deposition process includes a first deposition step performed at a first substrate temperature and a second deposition step performed after the first deposition step, and wherein the second deposition step is performed at a second substrate temperature different than the first substrate temperature.

17. The method of claim 16, wherein the first deposition step has a first etch/deposition (E/D) factor and the second deposition step has a second E/D factor greater than the first E/D factor.

18. The method of claim 16, wherein the first deposition step is a non-selective deposition; and the second deposition step is a selective deposition.

19. The method of claim 16, wherein the first substrate temperature is less than 620° C.; and the second substrate temperature is greater than 620° C.

20. The method of claim 16, wherein the deposition process includes a combination of the co-flow epitaxy growth and a cyclic deposition and etching (CDE) process.

21. The method of claim 16, wherein the epitaxially growing of the semiconductor material includes varying the E/D factor by a mechanism selected from gas partial pressure, gas flow rate, substrate temperature, and a combination thereof.

22. The method of claim 16, wherein the varying E/D factor includes a step-wise varying E/D factor.

22

23. A method of forming a field effect transistor (FET), the method comprising:

performing an etching process to a semiconductor substrate, thereby forming recesses in source and drain (S/D) regions of the semiconductor substrate;

forming, by a non-selective deposition process, a passivation layer of a first semiconductor material in the recesses;

after forming the passivation layer of the first semiconductor material, doping the passivation layer with fluorine atoms to form a fluorine-doped passivation layer; and

epitaxially growing a second semiconductor material over the fluorine-doped passivation layer, thereby forming S/D features in the recesses, wherein the first semiconductor material is different than the second semiconductor material, and wherein the epitaxially growing the second semiconductor material includes performing a cyclic deposition and etching (CDE) process having a first deposition step performed at a first temperature and a second deposition step performed at a second temperature different than the first temperature.

24. The method of claim 23, wherein the doping is performed by a fluorine plasma treatment.

25. The method of claim 23, wherein the fluorine-doped passivation layer has a fluorine concentration per unit area ranging from $1 \times 10^{14} \text{ cm}^{-2}$ to $2 \times 10^{15} \text{ cm}^{-2}$.

26. The method of claim 23, wherein the forming of the passivation layer includes performing the non-selective deposition process using a precursor free of chlorine; and the epitaxially growing of the second semiconductor material includes an etching process using a chlorine-containing gas.

27. The method of claim 23, wherein the forming of the passivation layer includes epitaxially growing the first semiconductor material that is free of dopant, using a precursor free of dopant-containing gas.

28. The method of claim 27, wherein the epitaxially growing of the second semiconductor material includes in-situ doping one of a n-type dopant and a p-type dopant to the second semiconductor material.

29. The method of claim 23, wherein the passivation layer is formed by the non-selective deposition process using a precursor that includes monomethylsilane (MMS) and at least one of silane (SiH₄) and disilane (SiH₆).

* * * * *