

Intel's Revolutionary 22 nm Transistor Technology

Mark Bohr
Intel Senior Fellow

Kaizad Mistry
22 nm Program Manager

May, 2011



Key Messages

- Intel is introducing revolutionary Tri-Gate transistors on its 22 nm logic technology
- Tri-Gate transistors provide an unprecedented combination of improved performance and energy efficiency
- 22 nm processors using Tri-Gate transistors, code-named Ivy Bridge, are now demonstrated working in systems
- Intel is on track for 22 nm production in 2H '11, maintaining a 2-year cadence for introducing new technology generations
- This technological breakthrough is the result of Intel's highly coordinated research-development-manufacturing pipeline
- Tri-Gate transistors are an important innovation needed to continue Moore's Law



Intel Technology Roadmap

Process Name	<u>P1266</u>	<u>P1268</u>	<u>P1270</u>	<u>P1272</u>	<u>P1274</u>
Lithography	45 nm	32 nm	22 nm	14 nm	10 nm
1 st Production	2007	2009	2011	2013	2015

Intel continues our cadence of introducing a new technology generation every two years



Traditional Planar Transistor

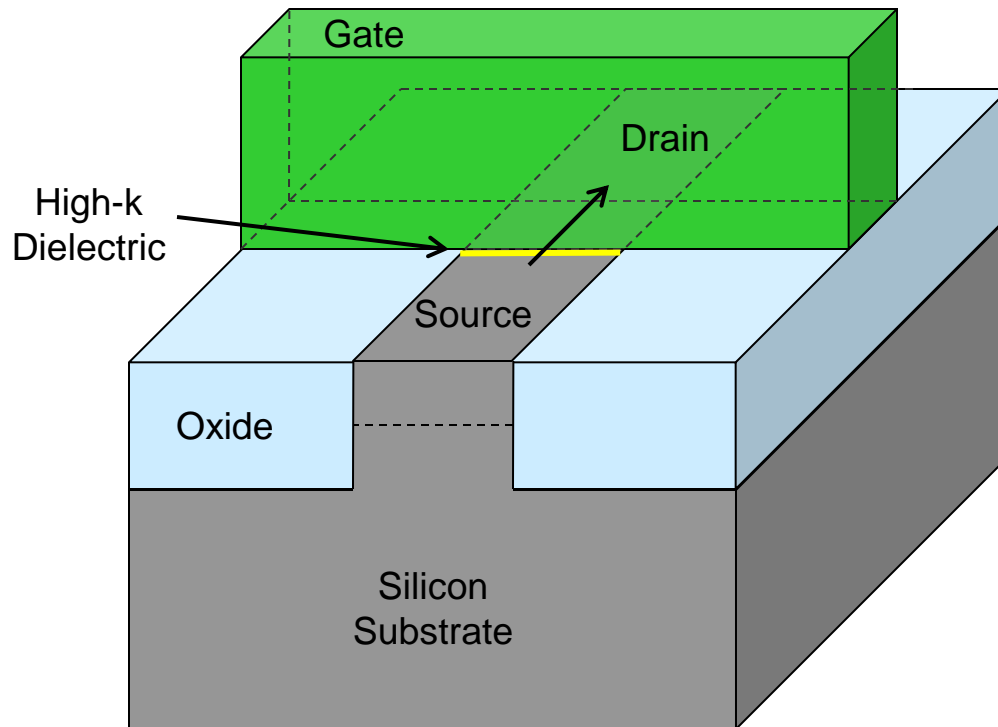

Traditional 2-D planar transistors form a conducting channel in the silicon region under the gate electrode when in the “on” state



22 nm Tri-Gate Transistor

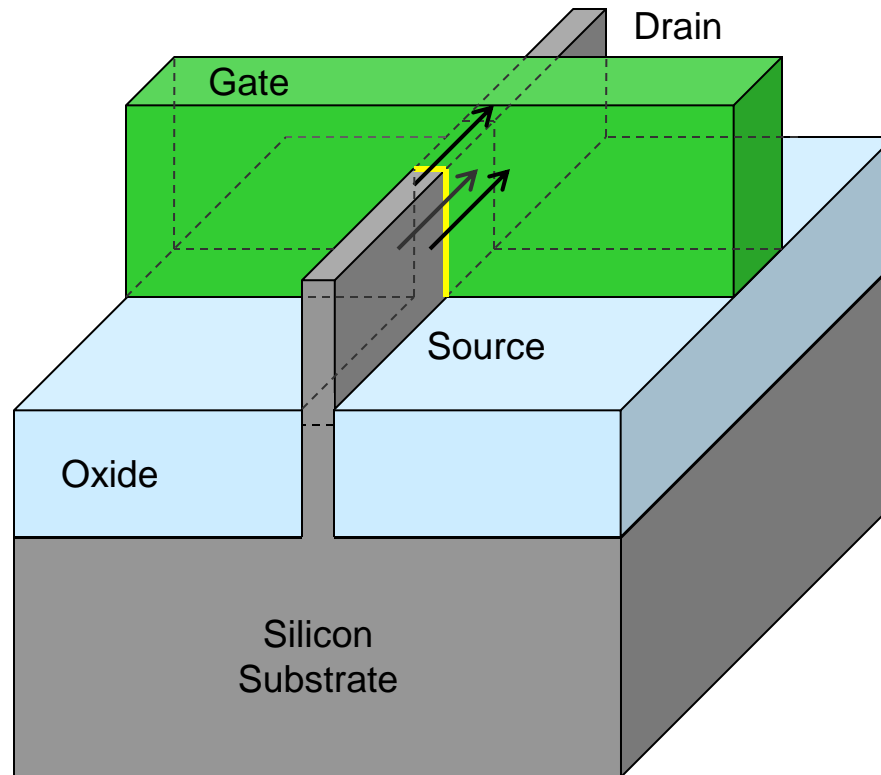

3-D Tri-Gate transistors form conducting channels on three sides of a vertical fin structure, providing “fully depleted” operation

Transistors have now entered the third dimension!



22 nm Tri-Gate Transistor

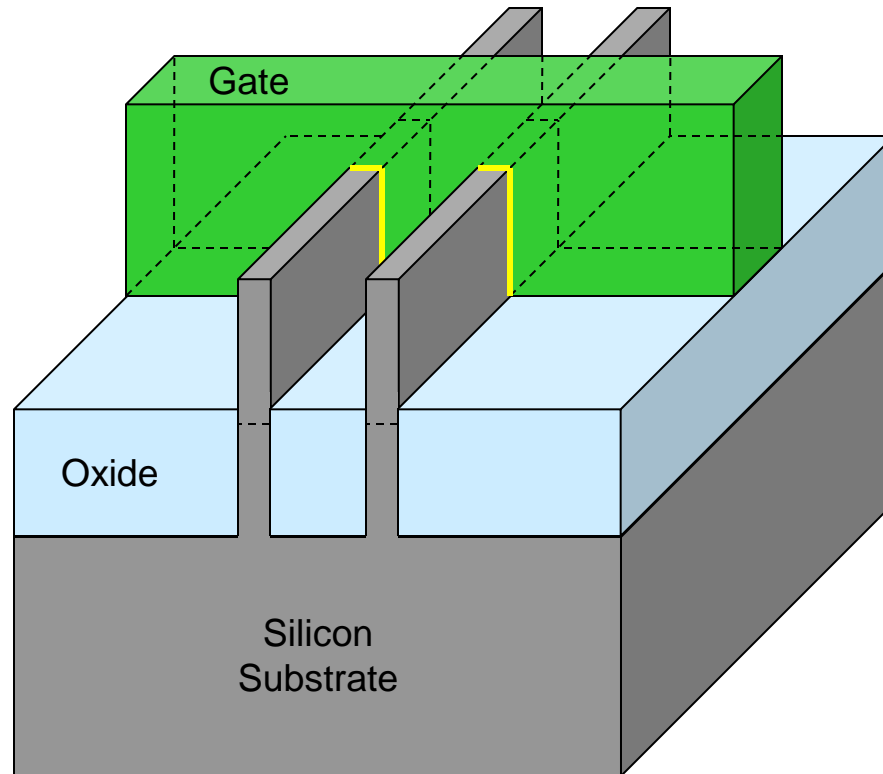

Tri-Gate transistors can have multiple fins connected together to increase total drive strength for higher performance



22 nm Tri-Gate Transistor

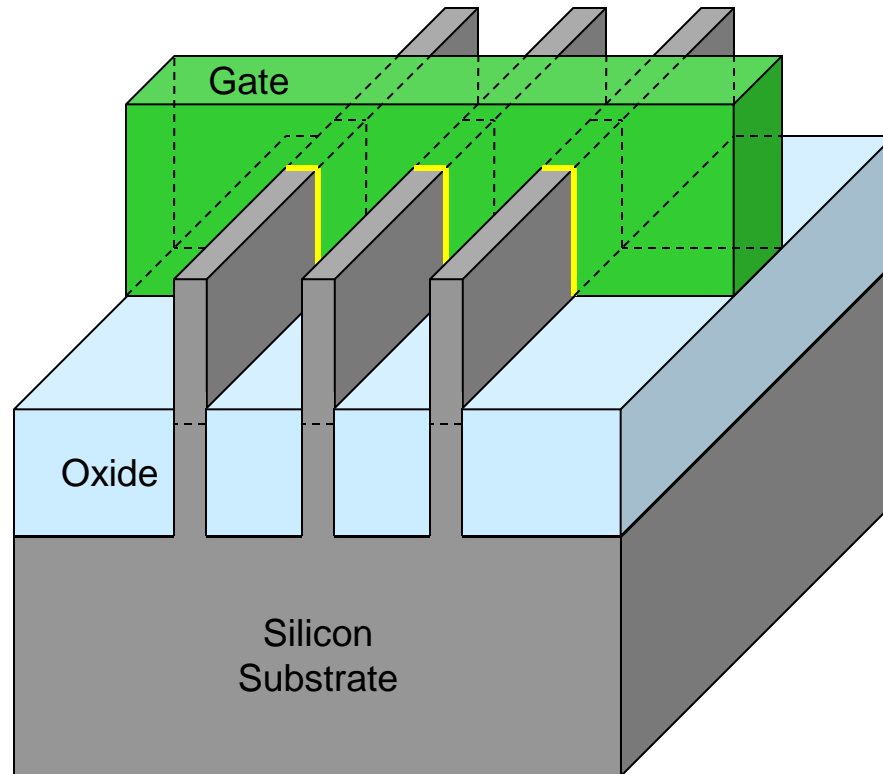

Tri-Gate transistors can have multiple fins connected together to increase total drive strength for higher performance



22 nm Tri-Gate Transistor

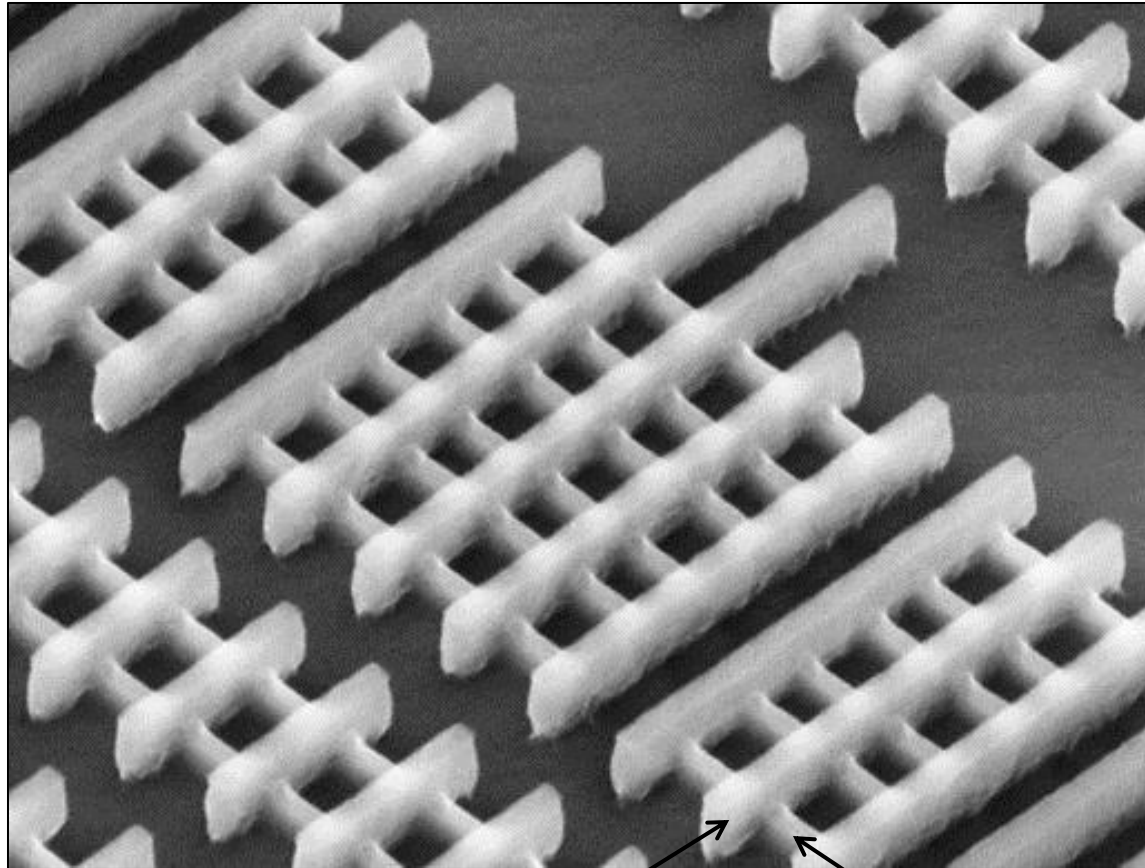

Gates

Fins



32 nm Planar Transistors

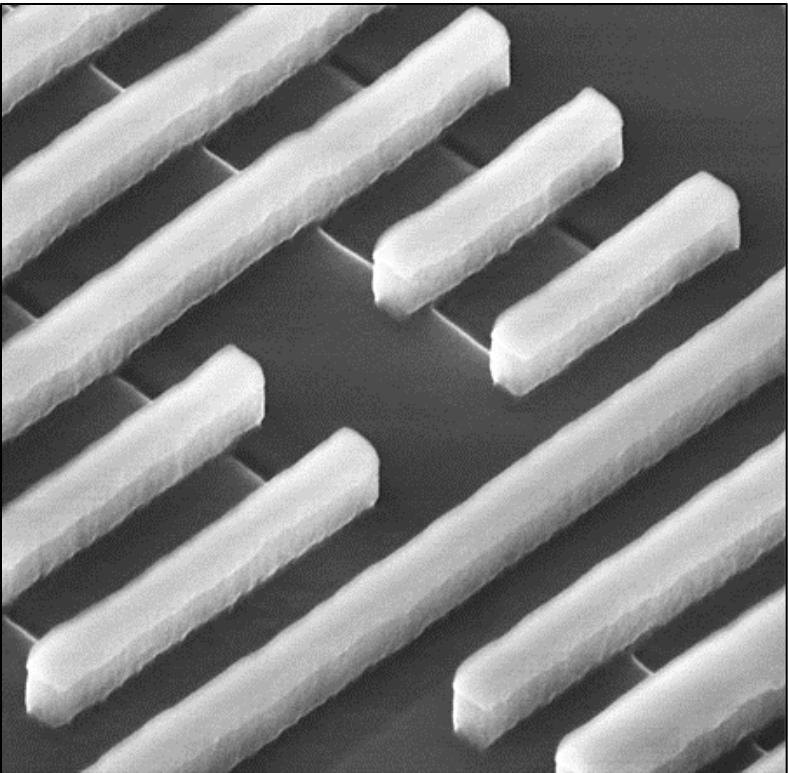

22 nm Tri-Gate Transistors

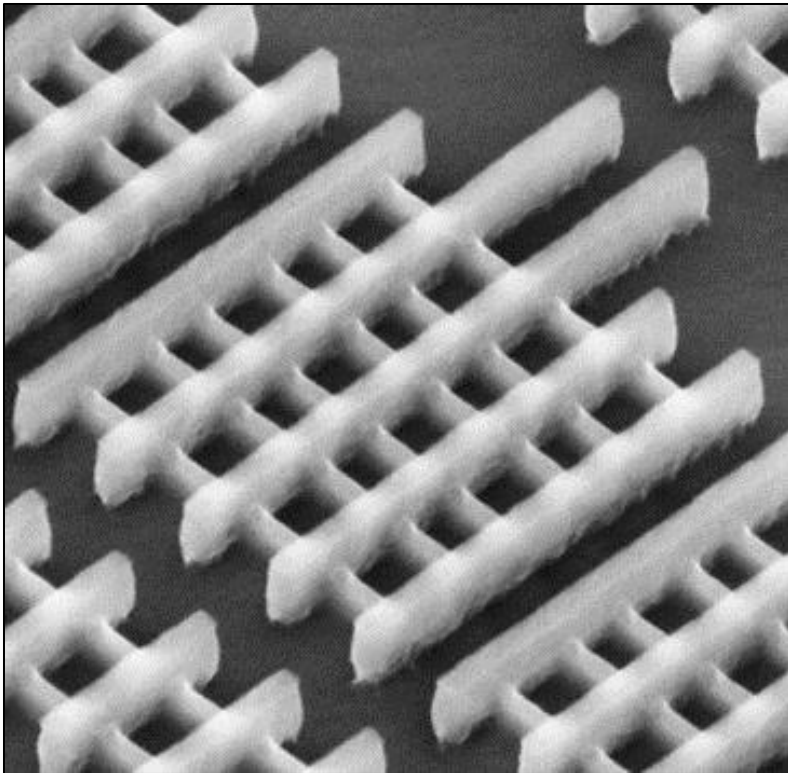

Intel Transistor Leadership

2003

90 nm

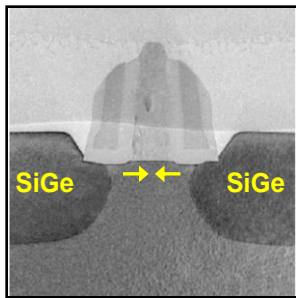

Invented
SiGe
Strained Silicon

2005

65 nm

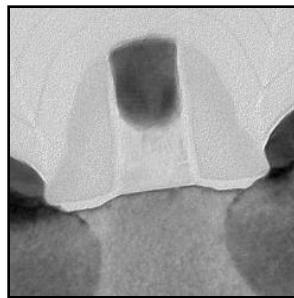

2nd Gen.
SiGe
Strained Silicon

2007

45 nm

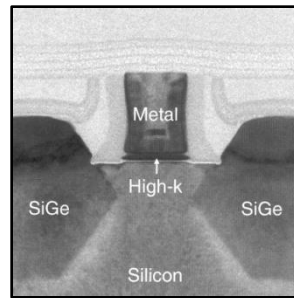

Invented
Gate-Last
High-k
Metal Gate

2009

32 nm

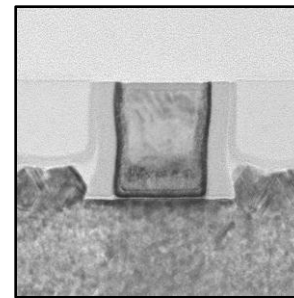

2nd Gen.
Gate-Last
High-k
Metal Gate

2011

22 nm

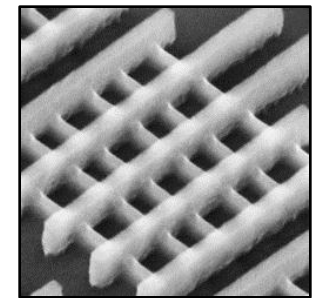

First to
Implement
Tri-Gate

Strained Silicon

High-k Metal Gate

Tri-Gate



Std vs. Fully Depleted Transistors

“Transistor 101”

Bulk Transistor

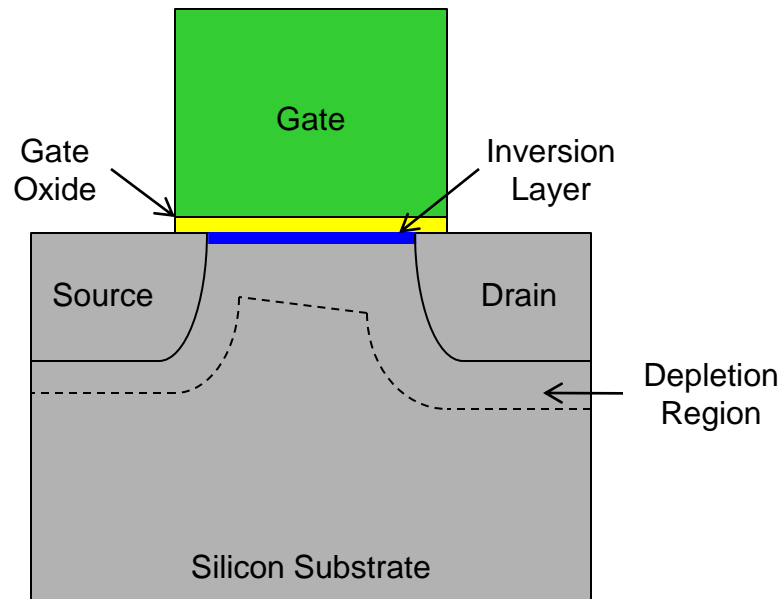

Silicon substrate voltage exerts some electrical influence on the inversion layer (where source-drain current flows)

The influence of substrate voltage degrades electrical sub-threshold slope (transistor turn-off characteristics)

NOT fully depleted



Std vs. Fully Depleted Transistors

Partially Depleted SOI (PDSOI)

“Transistor 101”

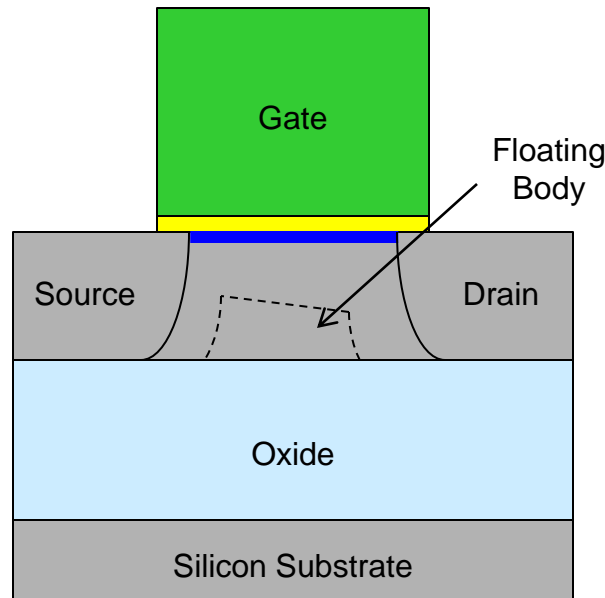

Floating body voltage exerts some electrical influence on the inversion layer, degrading sub-threshold slope

NOT fully depleted

Not used by Intel



Std vs. Fully Depleted Transistors

Fully Depleted SOI (FDSOI)

“Transistor 101”

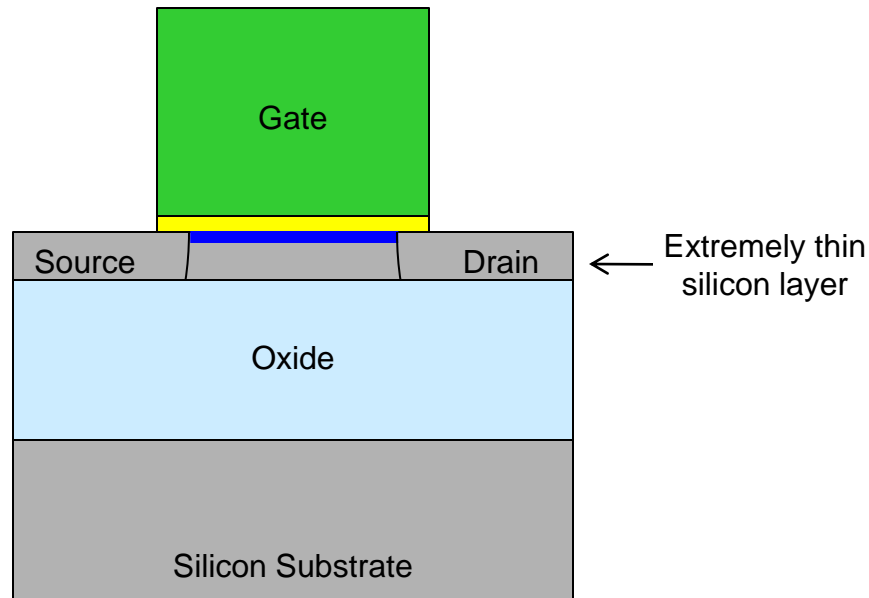

Floating body eliminated and sub-threshold slope improved

Requires expensive extremely-thin SOI wafer,
which adds ~10% to total process cost

Not used by Intel



Std vs. Fully Depleted Transistors

Fully Depleted Tri-Gate Transistor

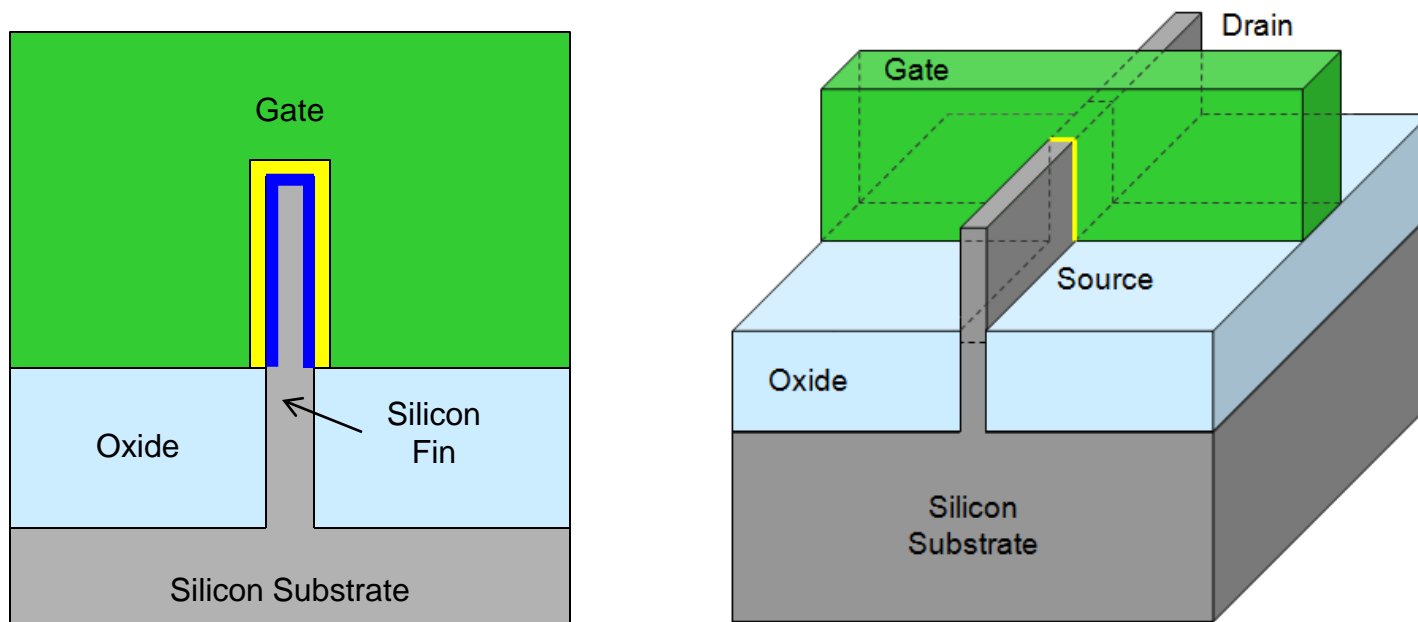

Gate electrode controls silicon fin from three sides
providing improved sub-threshold slope

Inversion layer area increased for higher drive current

Process cost adder is only 2-3%



Transistor Operation

“Transistor 101”

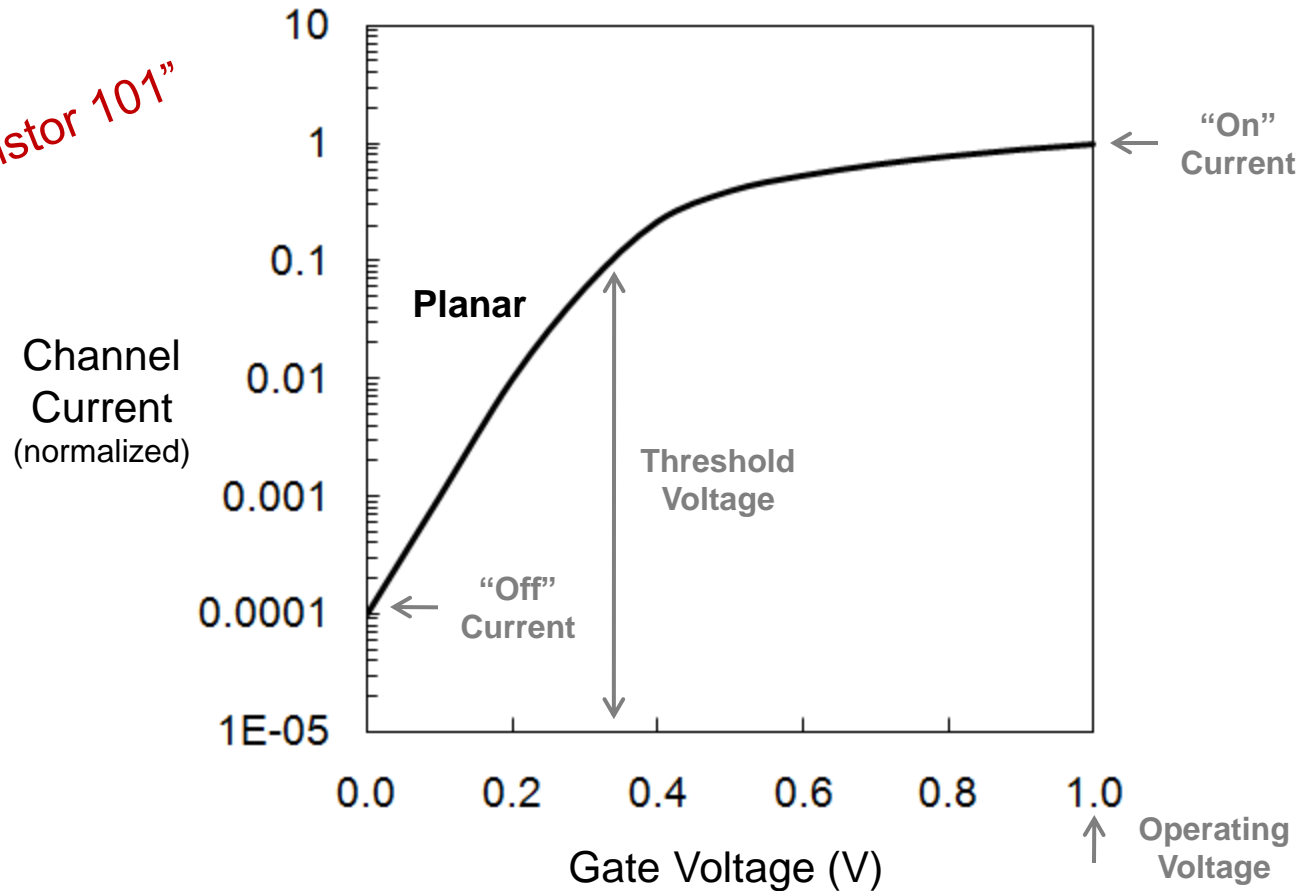

Transistor current-voltage characteristics



Transistor Operation

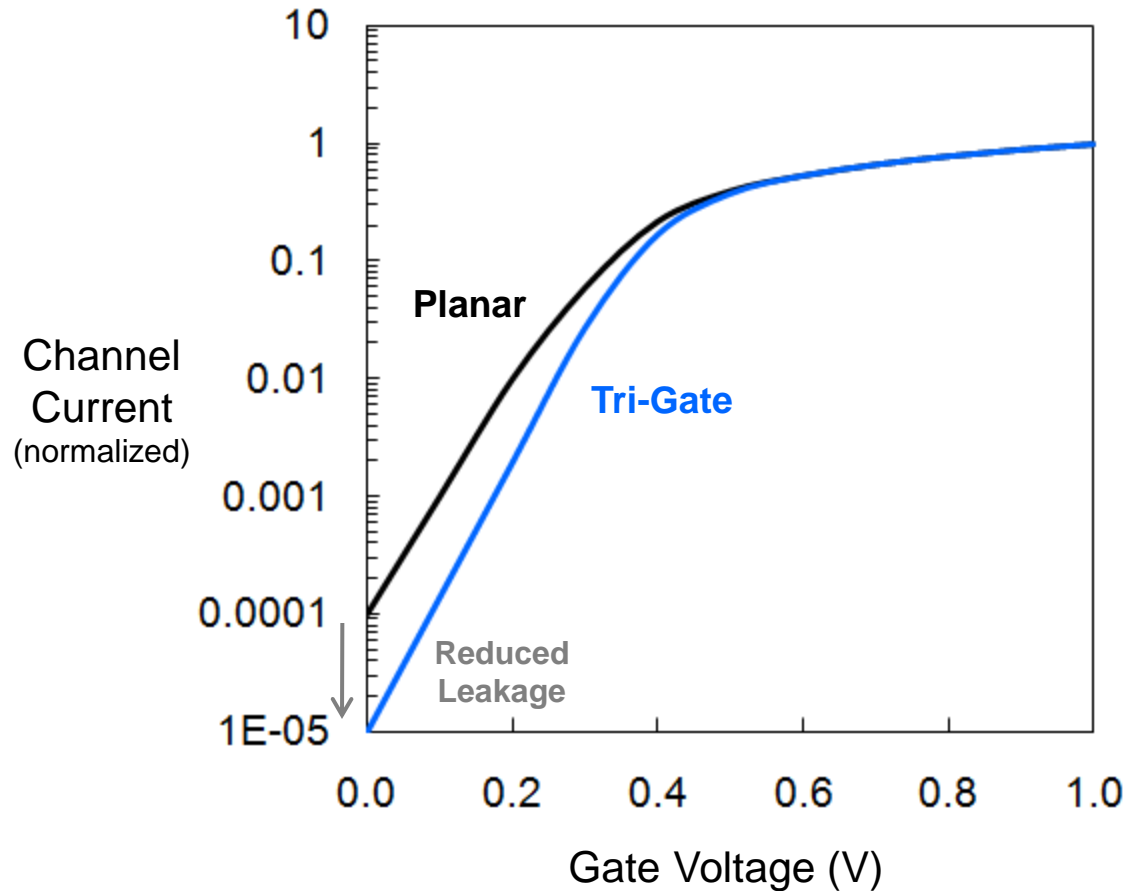

The “fully depleted” characteristics of Tri-Gate transistors provide a steeper sub-threshold slope that reduces leakage current



Transistor Operation

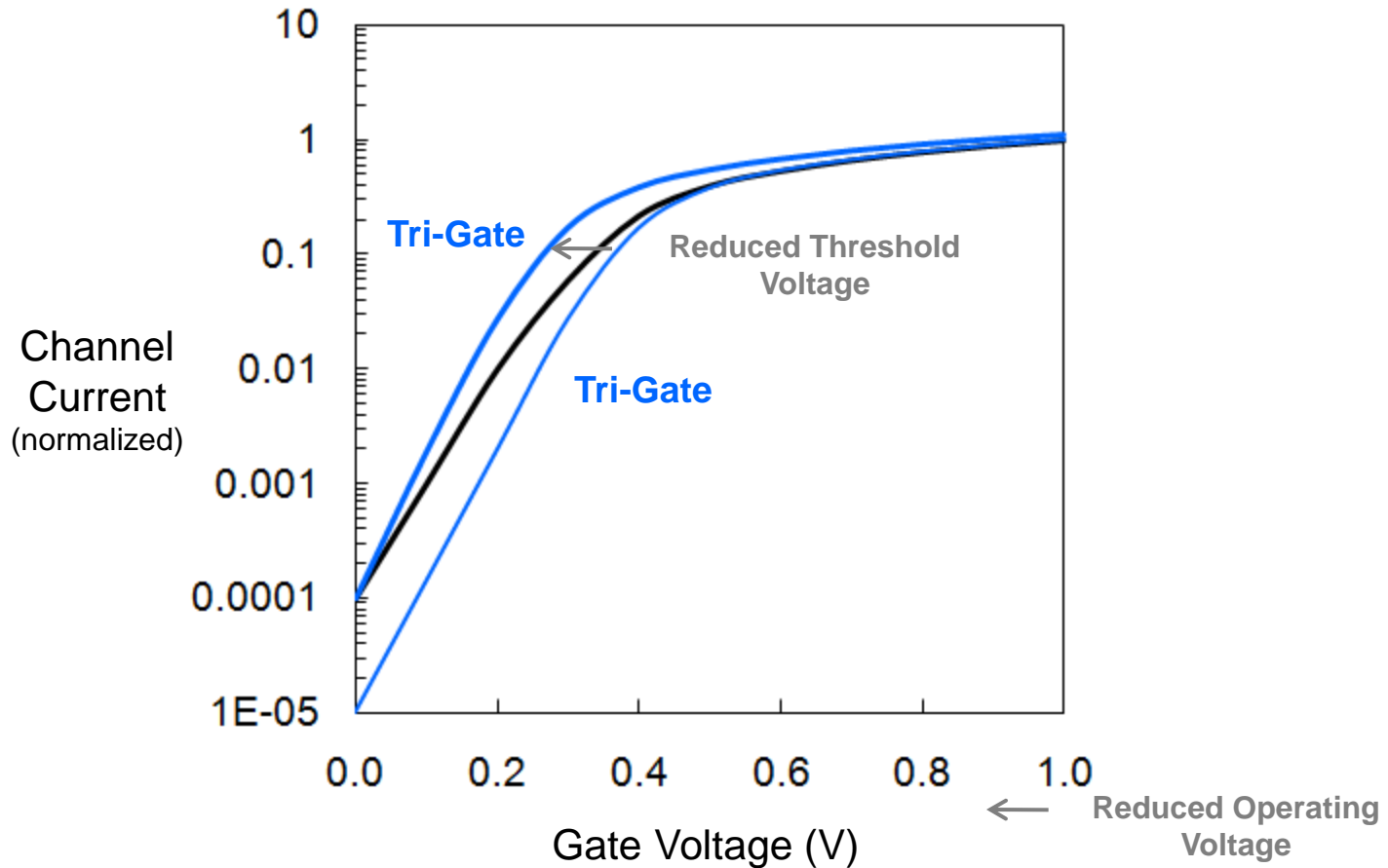

The steeper sub-threshold slope can also be used to target a lower threshold voltage, allowing the transistors to operate at lower voltage to reduce power and/or improve switching speed



Transistor Gate Delay

“Transistor 101”

Transistor
Gate Delay
(normalized)

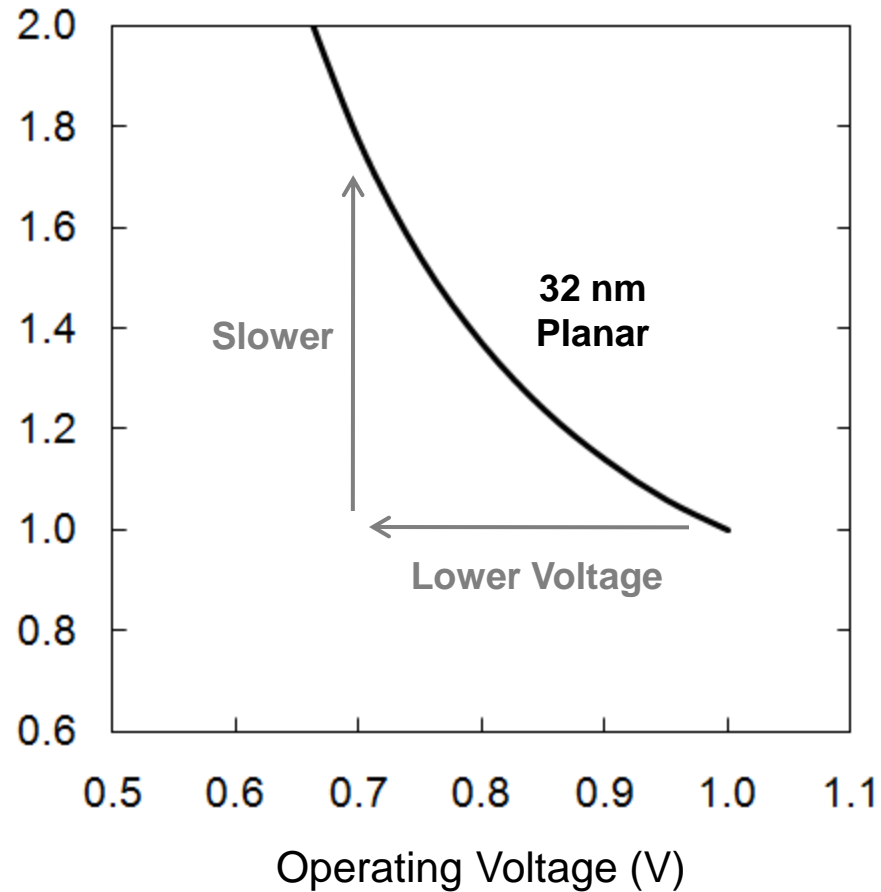

Transistor gate delay (switching speed) slows down
as operating voltage is reduced



Transistor Gate Delay

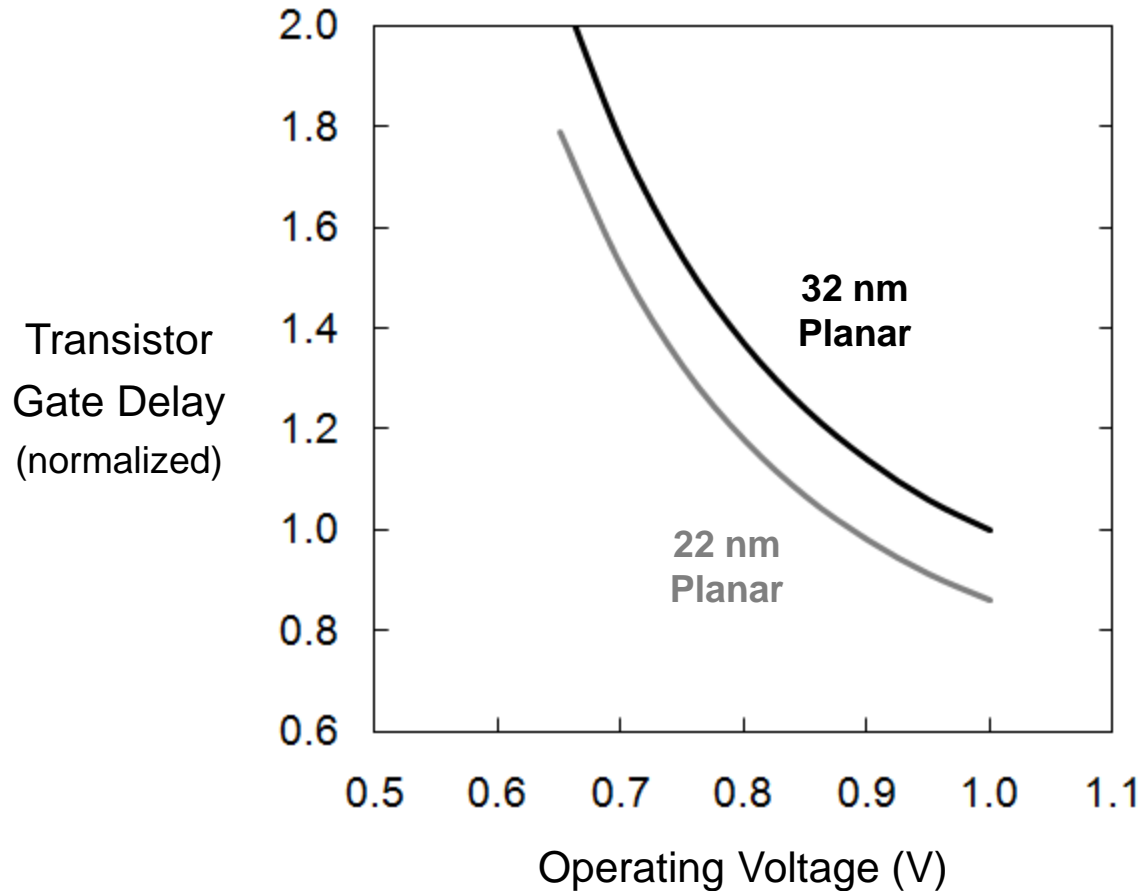

22 nm planar transistors could provide some performance improvement, but would still have poor gate delay at low voltage



Transistor Gate Delay

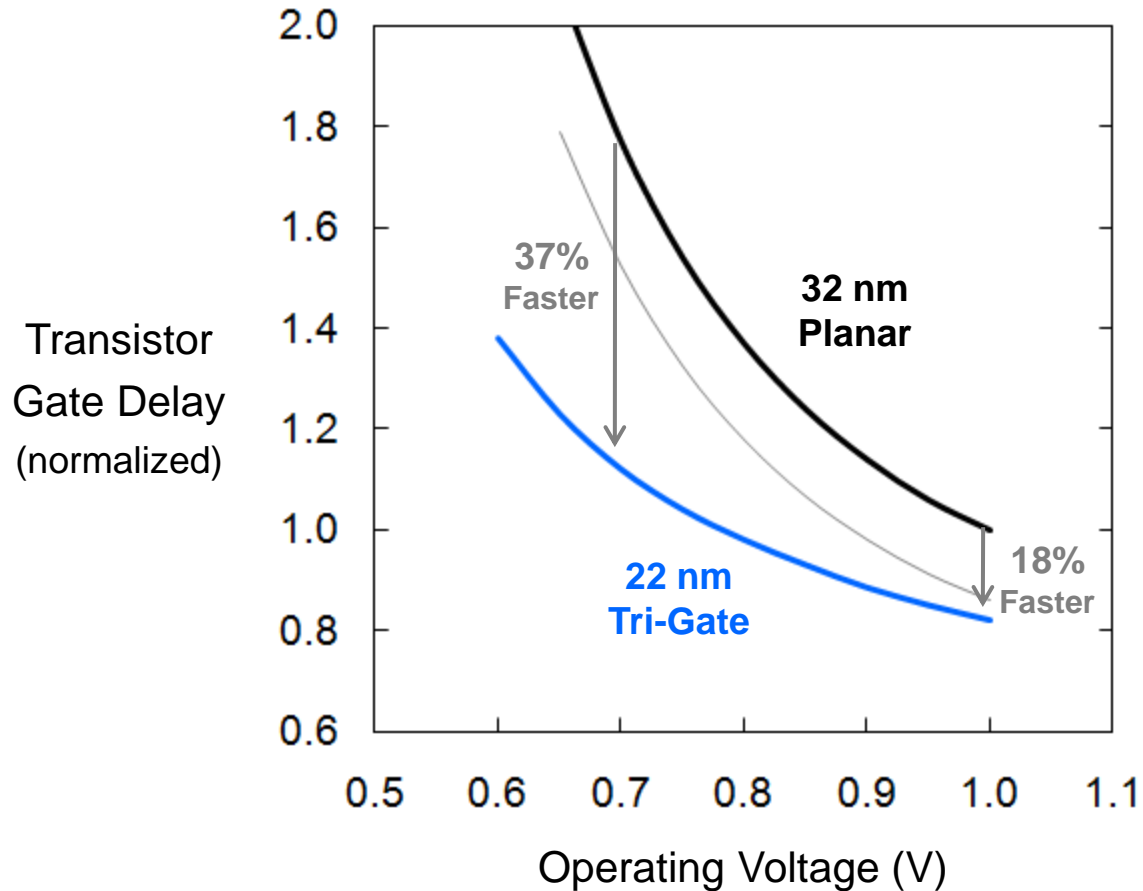

22 nm Tri-Gate transistors provide improved performance at high voltage and an *unprecedented* performance gain at low voltage



Transistor Gate Delay

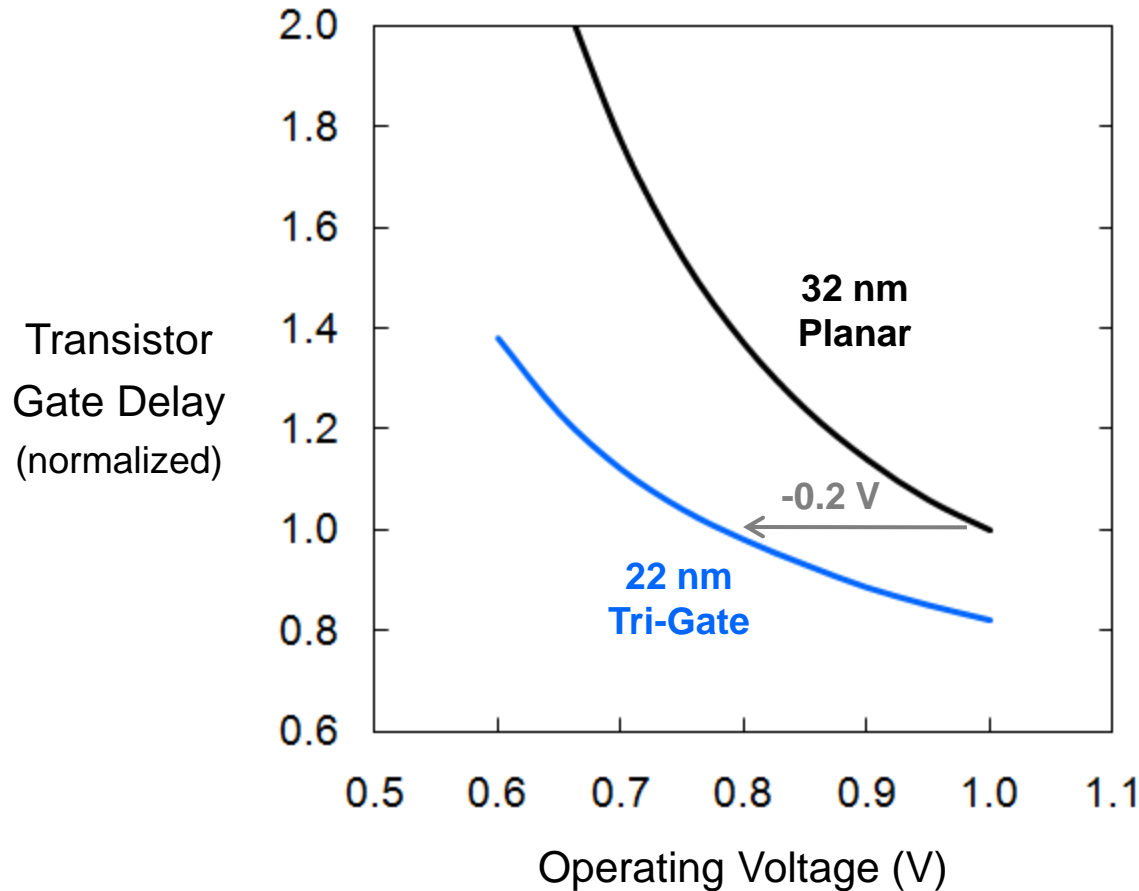

22 nm Tri-Gate transistors can operate at lower voltage with good performance, reducing active power by >50%



Tri-Gate Transistor Benefits

- Dramatic performance gain at low operating voltage, better than Bulk, PDSOI or FDSOI
 - 37% performance increase at low voltage
 - >50% power reduction at constant performance
- Improved switching characteristics (On current vs. Off current)
- Higher drive current for a given transistor footprint
- Only 2-3% cost adder (vs. ~10% for FDSOI)

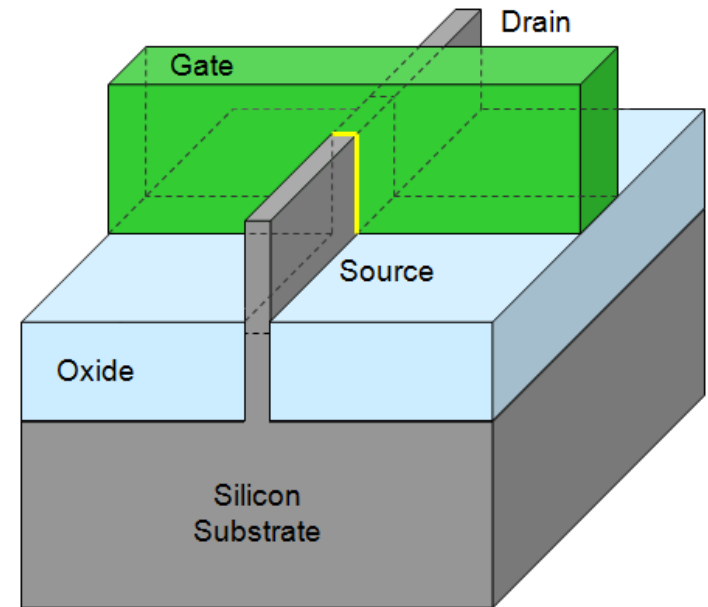

Tri-Gate transistors are an important innovation needed to continue Moore's Law



22 nm Tri-Gate Circuits

- 364 Mbit array size
- >2.9 billion transistors
- 3rd generation high-k + metal gate transistors
- Same transistor and interconnect features as on 22 nm CPUs

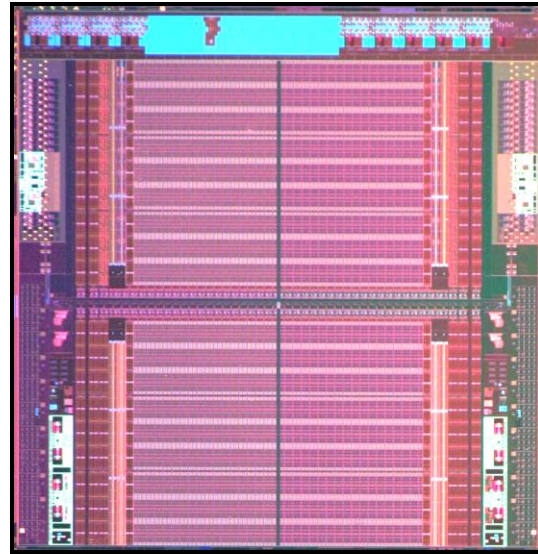

22 nm SRAM, Sept. '09

22 nm SRAMs using Tri-Gate transistors were first demonstrated in Sept. '09

Intel is now demonstrating the world's first 22 nm microprocessor (Ivy Bridge)
and it uses revolutionary Tri-Gate transistors



22 nm Manufacturing Fabs



D1C Oregon



Fab 28 Israel



D1D Oregon



Fab 32 Arizona



Fab 12 Arizona



On-Time 2 Year Cycles

90 nm

2003

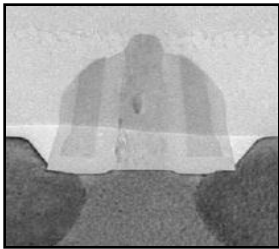

65 nm

2005

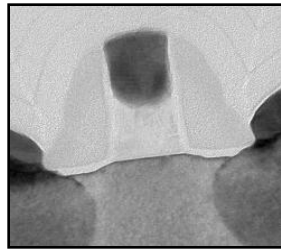

45 nm

2007

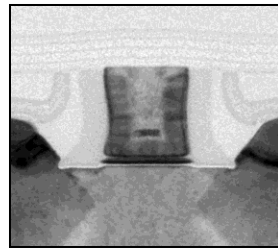

32 nm

2009

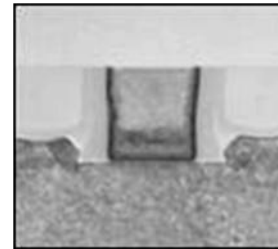

22 nm

2011

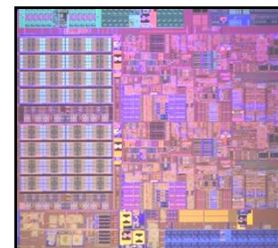
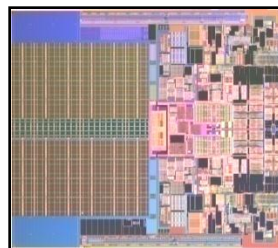
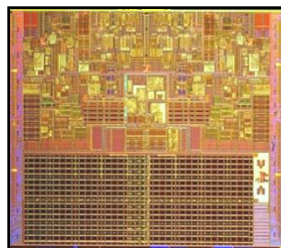
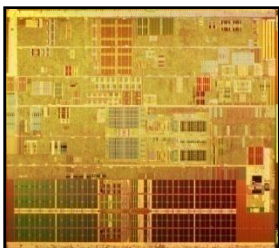
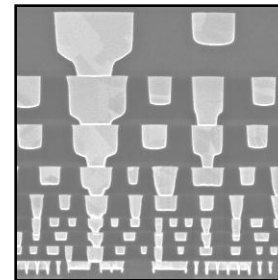
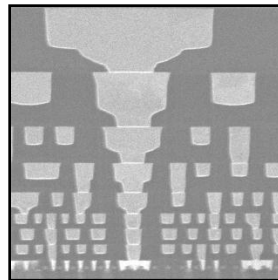
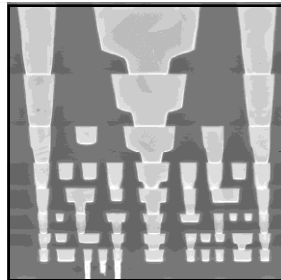
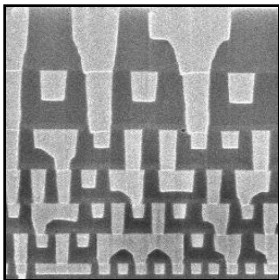
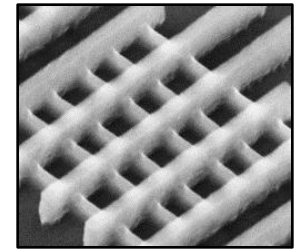

Intel continues to successfully introduce leading edge process + products on a 2 year cadence



Intel's R-D-M Pipeline

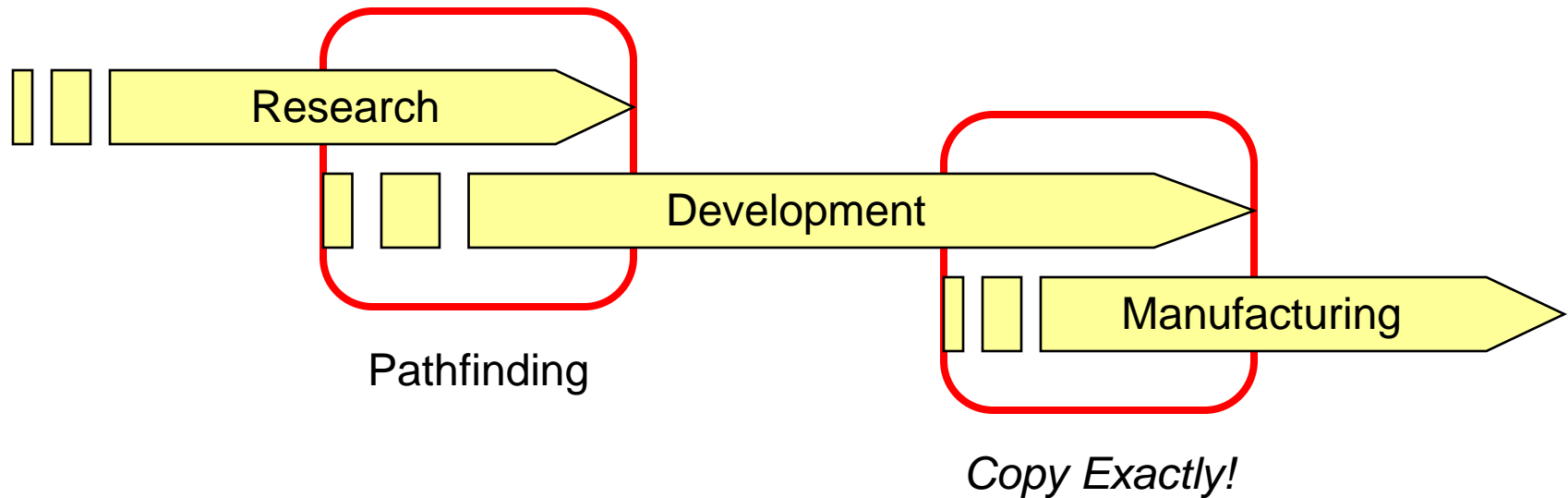

Bringing innovative technologies to high volume manufacturing is the result of a highly coordinated internal research-development-manufacturing pipeline



Key Messages

- Intel is introducing revolutionary Tri-Gate transistors on its 22 nm logic technology
- Tri-Gate transistors provide an unprecedented combination of improved performance and energy efficiency
- 22 nm processors using Tri-Gate transistors, code-named Ivy Bridge, are now demonstrated working in systems
- Intel is on track for 22 nm production in 2H '11, maintaining a 2-year cadence for introducing new technology generations
- This technological breakthrough is the result of Intel's highly coordinated research-development-manufacturing pipeline
- Tri-Gate transistors are an important innovation needed to continue Moore's Law



