

**IN THE UNITED STATES DISTRICT COURT
FOR THE EASTERN DISTRICT OF TEXAS
MARSHALL DIVISION**

HEADWATER RESEARCH LLC,	§	
	§	
Plaintiff,	§	
	§	
v.	§	NO. 2:23-CV-00103-JRG-RSP
	§	
SAMSUNG ELECTRONICS CO., LTD., and	§	
SAMSUNG ELECTRONICS AMERICA, INC.,	§	
	§	
Defendants.	§	

CLAIM CONSTRUCTION ORDER

Headwater Research LLC asserts patent infringement by Samsung Electronics Co., Ltd., and Samsung Electronics America, Inc., (together, “Samsung”) of claims from U.S. Patents 8,406,733, 9,198,117, and 9,615,192. The patents, which all reference the same four provisional applications,¹ generally relate to communications between mobile devices and servers. For example, the ’773 Patent’s claims concern control-plane communications between a device and a server and delivering messages from the server to particular device agents based on decrypted agent identifiers received over a “secure service control link.” ’733 Patent at [57]. Similarly, the ’117 Patent’s claims relate to securely delivering network messages from a server to devices using application identifiers that are mapped to corresponding software processes. ’117 Patent at [57]. The ’192 Patent’s claims concern buffering messages until a “trigger” occurs, like the expiration of a timer

¹ See ’733 Patent at [60]; ’117 Patent at [60]; ’192 Patent at [60]. The patents also appear to share much, if not all, of the same disclosure, but are not identified as being within the same patent family.

or a certain amount of service usage. '192 Patent at [57], 38:35–38.

The parties present five disputes about claim scope. For each dispute, Samsung contends the associated term is indefinite, whereas Headwater asserts the term has an ordinary and customary meaning that should apply. Having considered the parties' briefing and arguments of counsel during a July 11, 2024 hearing, the Court resolves the disputes as follows.

I. BACKGROUND

A. U.S. Patent 8,406,733

The claims of the '733 Patent relate to methods and devices for establishing a “control link” between a service controller and a service processor of a network device. *See* '733 Patent at [57]. For example, in Figure 16 (below), a service control link (1653) connects a service control server link (1638) of a service controller (122) and a service control device link (1691) of a device (100). The device link (1691) receives encrypted agent messages from the server link (1638) over the secure service control link (1653), uses an encryption key to obtain a decrypted message that has a particular agent identifier and message content, and, based on the decrypted agent identifier, delivers the message to the proper device agent (e.g., policy control agent (1692), access integrity agent (1694), or billing agent (1695)) over an agent communication bus (1630). The process “provide[s] an efficient and secure mechanism for transmitting and receiving service policy implementation, control, monitoring and verification information between the device agents (e.g., service processor agents/components) and other network elements” *Id.* at 68:54–58.

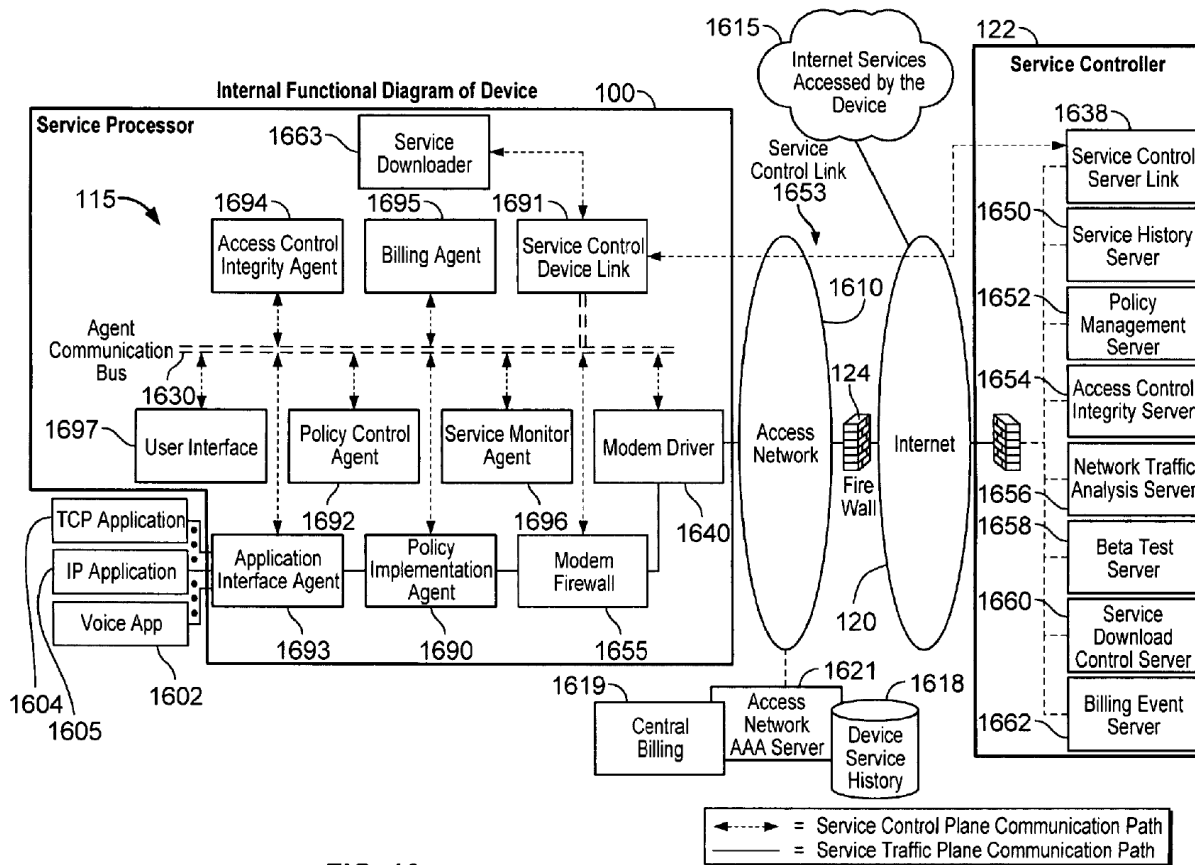

FIG. 16

The parties' disputes from this patent concern Claims 1, 19, and 30. Claim 1 recites:

1. An end-user device comprising:
 - a modem for enabling communication with a network system over a service control link provided by the network system over a wireless access network, the service control link secured by an encryption protocol and configured to support control-plane communications between the network system and a service control device link agent on the end-user device;
 - a plurality of **device agents** communicatively coupled to the service control device link agent through an agent communication bus, each of the plurality of **device agents** identifiable by an associated device agent identifier; and
 - memory configured to store an encryption key, the encryption key shared between the service control device link agent and

a service control server link element of the network system;
wherein the service control device link agent is configured to:
receive, over the service control link, an encrypted agent
message from the service control server link element,
using the encryption key, obtain a decrypted agent message,
the decrypted agent message comprising a particular
agent identifier and message content for delivery to a
particular device agent of the plurality of **device agents**,
the particular agent identifier identifying the particular
device agent, the message content from a particular
server of a plurality of servers communicatively coupled
to the service control server link element, and
based on the particular agent identifier, deliver the message
content to the particular device agent over the agent com-
munication bus.

'733 Patent at 163:47–164:12 (emphasis added). Claim 19, which depends from Claim 1, further requires “a user interface, and wherein the particular device agent is configured to *assist* in presenting a notification through the user interface, the notification based on the message content.” *Id.* at 165:4–8 (emphasis added). Claim 30 is directed to a three-step method performed by an end-user device of (i) receiving a message, (ii) decrypting the message, and (iii) delivering the message to the proper device agent. *Id.* at 166:16–39. Samsung challenges the definiteness of “device agent” in Claims 1 and 30 and “assist” in Claim 19.

B. U.S. Patent 9,198,117

The claims of the '117 Patent are directed to using a “device messaging agent” that securely communicates with a network message server over a wireless network. The message server sends messages to device messaging agents for network application servers, each of which provides the message server with application data, a device indication, and an application on the device for which the data is intended. The message server securely passes the data and the application

identifier to the messaging agent on the intended device. That messaging agent then maps the application identifier to a software process corresponding to the application and sends the data to that process. ’117 Patent at [57].

For claim construction, only Claim 1 is at issue:

1. A network system comprising:
 - a plurality of *device messaging agents*, each executable on a respective one of a plurality of mobile end-user devices configured to exchange Internet data via a data connection to a wireless network . . .
 - . . .
 - each *device messaging agent*, when executing,
 - to receive the Internet data messages from [a] secure Internet data connection corresponding to the device executing the *device messaging agent*, and
 - to, for each received message, map [an] application identifier in the message to a software process corresponding to the application identifier, and forward the application data in the message to the software process via a secure inter-process communication service.

’117 Patent at 163:44–164:15 (emphasis added). Samsung challenges “device messaging agent” as indefinite.

C. U.S. Patent 9,615,192

The claims of the ’192 Patent concern a message link server that maintains secure message links with device link agents on wireless end-user devices. As network elements send messages to the message link server, the server buffers messages targeted to each device until a “trigger” occurs. ’192 Patent at [57]. That trigger may be, for example, the expiration of a timer or a certain amount of service usage, *see id.* at 38:35–38, but is not merely the receipt of the message, *id.* at [57] (noting the message “may be buffered until the occurrence of a trigger other than the receipt

of that message by the server”).

Samsung challenges terms from Claims 1, 13, and 15 as indefinite. Claim 1 recites:

1. A message link server comprising:

a transport services stack to maintain a respective secure message link through an Internet network between the message link server and a respective device link agent on each of a plurality of wireless end-user devices, each of the wireless end-user devices comprising multiple **software components** authorized to receive and process data from secure message link messages received via a device link agent on that device;

an interface to a network to receive network element messages from a plurality of network elements, the received network element messages comprising respective message content and requests for delivery of the respective message content to respective wireless end-user devices, the respective message content including data for, and an identification of, a respective one of the authorized **software components**; and

a message buffer system including a memory and logic,

the memory to buffer content from the received network element messages for which delivery is requested to a given one of the wireless end-user devices,

the logic to determine when one of a plurality of message delivery triggers for the given one of the wireless end-user devices has occurred, wherein for at least some of the received network element messages, the receipt of such a message by the message buffer system is not a message delivery trigger, and for at least one of the message delivery triggers, the trigger is an occurrence of an asynchronous event with time-critical messaging needs, and

upon determining that one of the message delivery triggers has occurred, the logic further to supply one or more messages comprising the buffered content to the transport services stack for delivery on the secure message link maintained between the transport services stack and a device link agent on the given one of the wireless

end-user devices.

'192 Patent at 167:8–45 (emphasis added); *see also id.* at 168:43–169:10 (reciting, in Claim 15, a corresponding “method of operating a message link server”). Claim 13 requires that one of Claim 1’s “message delivery triggers is the receipt of a particular network element message from one of the network elements.” *Id.* at 168:36–38. From these three claims, Samsung asserts “software components” and “particular network element message” are indefinite.

II. GENERAL LEGAL STANDARDS

A. Generally

“[T]he claims of a patent define the invention to which the patentee is entitled the right to exclude.” *Phillips v. AWH Corp.*, 415 F.3d 1303, 1312 (Fed. Cir. 2005) (en banc). As such, if the parties dispute the scope of the claims, the court must determine their meaning. *See, e.g., Verizon Servs. Corp. v. Vonage Holdings Corp.*, 503 F.3d 1295, 1317 (Fed. Cir. 2007) (Gajarsa, J., concurring in part); *see also Markman v. Westview Instruments, Inc.*, 517 U.S. 370, 390 (1996), *aff’g*, 52 F.3d 967, 976 (Fed. Cir. 1995) (en banc).

Claim construction, however, “is not an obligatory exercise in redundancy.” *U.S. Surgical Corp. v. Ethicon, Inc.*, 103 F.3d 1554, 1568 (Fed. Cir. 1997). Rather, “[c]laim construction is a matter of [resolving] disputed meanings and technical scope, to clarify and when necessary to explain what the patentee covered by the claims” *Id.* A court need not “repeat or restate every claim term in order to comply with the ruling that claim construction is for the court.” *Id.*

When construing claims, “[t]here is a heavy presumption that claim terms are to be given their ordinary and customary meaning.” *Aventis Pharm. Inc. v. Amino Chems. Ltd.*, 715 F.3d 1363, 1373 (Fed. Cir. 2013) (citing *Phillips*, 415 F.3d at 1312–13). Courts must therefore “look to the words of the claims themselves . . . to define the scope of the patented invention.” *Id.* (citations

omitted). The “ordinary and customary meaning of a claim term is the meaning that the term would have to a person of ordinary skill in the art in question at the time of the invention, i.e., as of the effective filing date of the patent application.” *Phillips*, 415 F.3d at 1313. This “person of ordinary skill in the art is deemed to read the claim term not only in the context of the particular claim in which the disputed term appears, but in the context of the entire patent, including the specification.” *Id.*

Intrinsic evidence is the primary resource for claim construction. *See Power-One, Inc. v. Artesyn Techs., Inc.*, 599 F.3d 1343, 1348 (Fed. Cir. 2010) (citing *Phillips*, 415 F.3d at 1312). For certain claim terms, “the ordinary meaning of claim language as understood by a person of skill in the art may be readily apparent even to lay judges, and claim construction in such cases involves little more than the application of the widely accepted meaning of commonly understood words.” *Phillips*, 415 F.3d at 1314; *see also Medrad, Inc. v. MRI Devices Corp.*, 401 F.3d 1313, 1319 (Fed. Cir. 2005) (“We cannot look at the ordinary meaning of the term . . . in a vacuum. Rather, we must look at the ordinary meaning in the context of the written description and the prosecution history.”). But for claim terms with less-apparent meanings, courts consider “those sources available to the public that show what a person of skill in the art would have understood disputed claim language to mean . . . [including] the words of the claims themselves, the remainder of the specification, the prosecution history, and extrinsic evidence concerning relevant scientific principles, the meaning of technical terms, and the state of the art.” *Phillips*, 415 F.3d at 1314.

B. Indefiniteness

“[A] patent is invalid for indefiniteness if its claims, read in light of the specification delineating the patent, and the prosecution history, fail to inform, with reasonable certainty, those skilled in the art about the scope of the invention.” *Nautilus, Inc. v. Biosig Instruments, Inc.*, 572

U.S. 898, 901 (2014). The claims “must be precise enough to afford clear notice of what is claimed” while recognizing that “some modicum of uncertainty” is inherent due to the limitations of language. *Id.* at 908. “Indefiniteness must be proven by clear and convincing evidence.” *Sonix Tech. Co. v. Publ’ns Int’l, Ltd.*, 844 F.3d 1370, 1377 (Fed. Cir. 2017).

III. THE LEVEL OF ORDINARY SKILL IN THE ART

The level of ordinary skill in the art is the skill level of a hypothetical person who is presumed to have known the relevant art at the time of the invention. *In re GPAC*, 57 F.3d 1573, 1579 (Fed. Cir. 1995). In resolving the appropriate level of ordinary skill, courts consider the types of and solutions to problems encountered in the art, the speed of innovation, the sophistication of the technology, and the education of workers active in the field. *Id.* Importantly, “[a] person of ordinary skill in the art is also a person of ordinary creativity, not an automaton.” *KSR Int’l Co. v. Teleflex Inc.*, 550 U.S. 398, 421 (2007).

Here, Samsung asserts a skilled artisan “would have had (1) at least a bachelor’s degree in computer science, electrical engineering, or a related field; and (2) 3–5 years of experience in services and application implementation in communication networks.” Dkt. No. 96 at 5 (quoting Turnbull Decl., Dkt. No. 94-7 ¶ 30). Headwater does not challenge this level of skill. Accordingly, the Court adopts Samsung’s characterization of a skilled artisan to resolve the present disputes.

IV. THE DISPUTED TERMS

A. “device agents” (’733 Patent, Claims 1, 30)

Headwater’s Construction	Samsung’s Construction
Not indefinite; plain and ordinary meaning	Indefinite. Alternatively, “device agents” excludes “applications.”

Claim 1 cites a device comprising “a plurality of *device agents* communicatively coupled

to the service control device link agent through an agent communication bus, each of the plurality of *device agents* identifiable by an associated device agent identifier.” ’733 Patent at 163:55–59. Samsung asserts “device agents” is indefinite or, alternatively, that the term’s scope does not include “applications.”

To start, Samsung says “device agent” does not have a commonly understood meaning in the art, and the intrinsic record fails to provide any guidance about that meaning. Dkt. No. 96 at 6–8. Samsung notes the specification only uses the term a few times, none of which “meaningfully delineate” the term’s scope. *Id.* at 8. Moreover, combining the individual meanings of “device” and “agent” does not resolve the issue. *Id.* In fact, argues Samsung, Headwater’s interpretation of the term shows the ambiguity by contradicting the specification, in part by reading “device agents” to include “applications.” *Id.* at 10 (citing Headwater’s Infringement Contentions, Dkt. No. 96-5 at 14).

Headwater, however, argues a “device agent” is simply an “agent” on a device. Dkt. No. 94 at 4. It cites Samsung’s expert’s opinion that “agent” ordinarily means “software that performs certain functions on behalf of another element.” *Id.* at 4 (citing Turnbull Decl., Dkt. No. 94-7 ¶ 33 (citing dictionary definitions)). And even if “agent” does not have an ordinary meaning, Headwater says the patent provides reasonable certainty as to its scope. *Id.* at 5–6 (citing Figures 16–21). Finally, Headwater stresses that the references cited during prosecution, Samsung’s own documents, and Samsung’s patents all use “device agent,” which shows the term is not indefinite. *Id.* at 7–8.

The Court agrees with Headwater. For one, Samsung’s expert admits “agent” has a “plain and ordinary meaning” at least in networking, Turnbull Decl., Dkt. No. 94-7 ¶ 33 (“In the context of a computer network, ‘agent’ means software that performs certain functions on behalf of another

element.”), and multiple technical dictionaries support that meaning’s applicability here. *See* Dictionary of Computer & Internet Terms (10th 2009), Dkt. No. 94-9 at 15 (defining “agent” as software that “performs a service for someone,” such as an agent “run[ning] on a client computer to keep the server informed of its needs”); *see also* Turnbull Decl., Dkt. No. 94-7 ¶ 33 (citing *agent*, Newton’s Telecom Dictionary 95 (24th ed. 2008) (“software that runs on a client computer for use by administrative software running on a server”)).

Yet Samsung suggests “agent” and “device agent” are different things, and contests that “device” simply limits the location of the “agent.” After all, says Samsung, “device agent” *might* mean “an agent *for* the device” rather than an agent “on the device.” Dkt. No. 96 at 9. But nothing in the intrinsic record suggests that interpretation. As Samsung explained at the hearing, the invention’s purpose is to move some of the functionality of the server *onto the device*. And Figure 16 shows “a plurality of agents” on the device, none of which is acting as an agent *for the device* as a whole. Thus, Samsung’s alternative interpretation runs counter to the invention’s purpose as described by Samsung and is not supported by the specification.

At the hearing, Samsung also argued that if a “device agent” is simply “an agent on the device,” the “service control device link agent” would also be a “device agent,” which Samsung suggested is inconsistent with the claim. But that the ordinary meaning of “device agent” might be broad enough to include the “service control device link agent” does not, without more, affect the former’s scope. Samsung seems to confuse the presumption that different claim terms have different meanings with the implication that separately listed elements are distinct. Here, for example, there is an implication that whatever meets the “service control device link agent” requirement for purposes of infringement is distinct from whatever meets the separately recited “plurality of device agents.” *See Becton, Dickinson & Co. v. Tyco Healthcare Grp., LP*, 616 F.3d 1249, 1254 (Fed. Cir.

2010) (“Where a claim lists elements separately, ‘the clear implication of the claim language’ is that those elements are ‘distinct component[s]’ of the patented invention.” (quoting *Gaus v. Conair Corp.*, 363 F.3d 1284, 1288 (Fed. Cir. 2004)). But that implication doesn’t render the ordinary meaning of “device agents” somehow inapplicable or ambiguous.

Samsung also argues that a broad construction of “device agent,” such as the preliminary construction the Court provided at the hearing,² contradicts the specification for two reasons. First, Samsung points to Figure 13 (below), which it contends shows a service processor that includes all of the device agents and that is external to the device. That, says Samsung, is inconsistent with the Court’s preliminary construction. Second, Samsung claims a broad interpretation of “device agents” could be read to include “applications,” even though the patent separately identifies those two things.

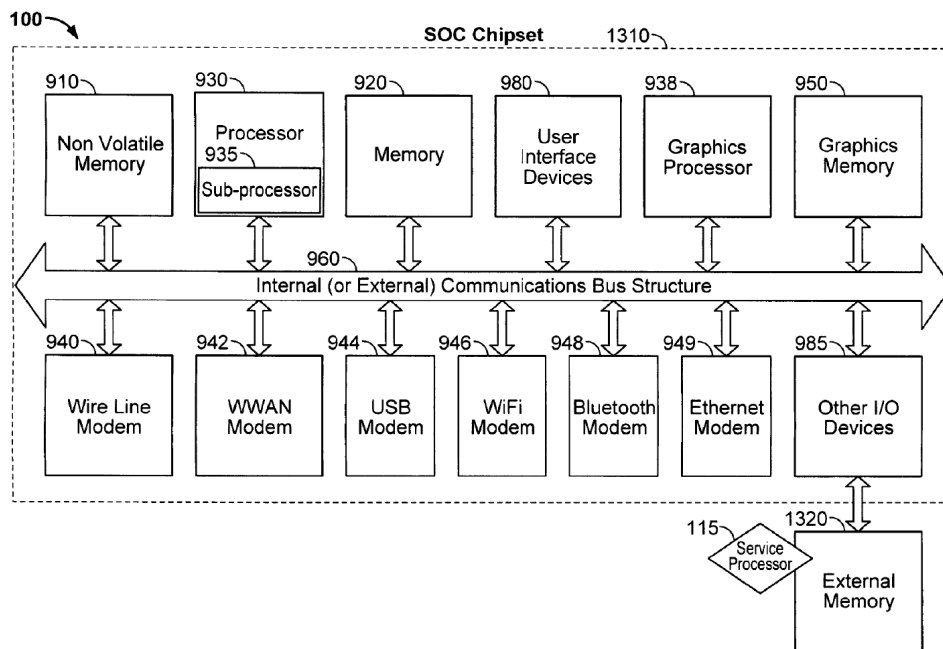

FIG. 13

² At the hearing, the Court tentatively construed this term as “a piece of software on the end-user device that performs certain functions for other software.”

Neither argument is persuasive. First, Figure 13 does not show a service processor that is external to the device. Rather, Figure 13 illustrates a “hardware diagram of a device 100 *that includes a service processor* 115 implemented in external memory of a System On Chip (SOC).” ’733 Patent at 31:27–30 (emphasis added). Thus, nothing about Figure 13 is inconsistent with the Court’s preliminary construction for “device agents.” And regarding its agents-or-applications argument, Samsung fails to consider there might be at least some overlap between the two. While “device agents” and “apps” clearly have different meanings, that does not, without more, indicate mutual exclusivity between those meanings. For example, at the hearing, Headwater agreed downloadable apps are not “device agents” themselves, but suggested they might include “device agents.”

Reading the claims in the proper context, “device” simply distinguishes “agents” on the device from other “agents,” such as those on a server, and nothing about that interpretation is inconsistent with the specification. Thus, in accordance with Samsung’s expert’s explanation for the term and the Court’s preliminary construction, the Court construes “device agent” as “a piece of software on the end-user device that performs certain functions for other software.”

B. “wherein the particular device agent is configured to assist in presenting a notification through the user interface, the notification based on message content” (’733 Patent, Claim 19)

Headwater’s Construction	Samsung’s Construction
Not indefinite; plain and ordinary meaning	Indefinite

The device of Claim 1 requires a “service control device link agent” configured to “obtain a decrypted agent message . . . comprising a particular agent identifier and message content for delivery to a particular device agent [and,] based on the particular agent identifier, deliver the message content to the particular device agent over the agent communication bus.” ’733 Patent at

164:1–12. Claim 19 narrows the device of Claim 1 to include “a user interface, and wherein the particular device agent is *configured to assist* in presenting a notification through the user interface” *Id.* at 165:4–8 (emphasis added).

The parties’ dispute about this phrase focuses on the word “assist.” Samsung asserts a skilled artisan would not know whether a device agent is “configured to assist in presenting a notification.” In its view, “[w]hether something ‘assists’ is a subjective term of degree.” Dkt. No. 96 at 17 (asking “if a given component stores or processes information that is ultimately displayed through a user interface, does it necessarily ‘assist’ in that presentation?”). But according to Headwater, Samsung’s expert conceded the term was not indefinite during his deposition, and he provides only a conclusory sentence in his declaration that the term is indefinite. Dkt. No. 94 at 9 (citing Turnbull Depo. Tr., Dkt. No. 94-8 at 88:23–89:9; Turnbull Decl., Dkt. No. 94-7 ¶ 42). Headwater points to “a universally understood meaning” of “to give support or aid to” and contests that “assist” is a term of degree. Dkt. No. 99 at 6.

This phrase is not indefinite. For one, the Court agrees that Dr. Turnbull’s declaration on this term is conclusory. He only states “it is not clear how a POSITA would have determined whether a particular component ‘assist[s]’ in that presentation,” Turnbull Decl., Dkt. No. 94-7 ¶ 42, but without any explanation about why that’s true from the perspective of a skilled artisan.

Regardless, “assist” is not a term of degree. As Headwater notes, “assist” is a verb—not an adjective or an adverb. Ultimately, the claim simply recites the typical role of an “agent” in a computer system—assisting another part of the system by performing certain functions. Here, Claim 19 narrows “device agent” to one that performs its agency duties for a specific purpose—presenting a notification based on the message content through the user interface. Accordingly, given the construction for “device agents” *supra*, the Court will give this phrase a “plain and

ordinary meaning” construction.

C. “device messaging agents” (’117 Patent, Claim 1)

Headwater’s Construction	Samsung’s Construction
Not indefinite; plain and ordinary meaning	Indefinite

This dispute is similar to the earlier dispute about “device agents.” *See* Part IV.A. *supra*. The claim recites “a plurality of *device messaging agents*, each executable on a respective one of a plurality of mobile end-user devices configured to exchange Internet data via a data connection to a wireless network” ’117 Patent at 163:47–50 (emphasis added). Samsung first notes the term is not known in the art and then argues the claim’s recitation of the term is inconsistent with how the ’733 Patent uses “device agents.” Dkt. No. 96 at 19–20. It then notes the specification does not use “device messaging agents” outside of the claims and abstract, which makes the term “especially suspect,” and the file history of a related patent confirms the “arbitrary nature” of the phrase. *Id.* at 20 (citing to the file wrapper for U.S. Appl’n No. 14/667,353). It also argues the specification requires “device agents” to be involved in “service policy” or “management” functions, which further muddies the term’s scope. *Id.* at 20 (citing ’117 Patent at 11:35–40, 15:58–60).

Samsung’s position is not persuasive. For one, that the term is not in the specification does not make it indefinite, or even “especially suspect.” And regarding the ’353 Application’s file history, the Court sees nothing in the applicant’s response inconsistent with the idea that a “device messaging agent” is a “device agent” for “messaging.” For example, the applicant explained the “service control device link” of Figure 18 is “equivalent to an agent for communication purposes,” and that “data units passed between the service control server link and the service control device link are referred to interchangeably as “communications,” “communication messages,” and

“messages.” Amendment & Resp., Dkt. No. 96-6 at 7 (SAM-HW-2_00216549). Samsung argues the applicant’s position “divorces the term for the only defining characteristics in the specification,” Dkt. No. 96 at 20, but that presumes the term is coined and fails to consider how a skilled artisan would understand “device messaging agent” notwithstanding the patent. Ultimately, however, there is no dispute about what an “agent” is, that “agents” perform different functions, and that “messaging” is one of those functions. “Device” and “messaging” are simply modifiers of “agent.”

Notably, the claim itself helps set forth the scope of the term. Specifically, each “device messaging agent” “receive[s] the Internet data messages from the secure Internet data connection corresponding to the device . . . , and for each received message, map[s] the application identifier in the message to a software process corresponding to the application identifier, and forward[s] the application data in the message to the software process via a secure interprocess communication service.” ’117 Patent at 164:7–15. While a “device messaging agent” in the abstract may perform other functions, the agent of Claim 1 must perform at least these. But as for the term’s ordinary meaning, consistent with its construction for “device agents,” the Court construes “device messaging agent” as “a piece of software on a mobile end-user device that performs certain messaging functions for other software.”

D. “software components” (’192 Patent, Claims 1, 4, 15)

Headwater’s Construction	Samsung’s Construction
Not indefinite; plain and ordinary meaning	Indefinite

Samsung argues “the ’192 patent makes the meaning of ‘software components’ unclear in light of its disclosures regarding ‘device agents.’” Dkt. No. 96 at 22. Its position centers on Claim 1’s use of both “software components” and “device link agent,” which Samsung says must

have different meanings. *Id.* at 23 (citing *SimpleAir, Inc. v. Sony Ericsson Mobile Commc'ns AB*, 820 F.3d 419, 431 (Fed. Cir. 2015)). More specifically, Samsung reasons that “[i]f ‘software components’ refers to all software functionalities that do not qualify as ‘device agents,’ it necessarily follows that ‘software components’ is indefinite.” *Id.* “In other words, if ‘software components’ encompasses everything that a device agent is not, and the bounds of ‘device agents’ are indeterminate, then the bounds of ‘software components’ are also indeterminate.” *Id.*

Headwater notes Samsung’s expert’s agreement that “software components” has a plain meaning to a skilled artisan. Dkt. No. 94 at 13. As for Samsung’s argument about the possible mutual exclusivity between “software components” and “device agents,” Headwater argues the claim language resolves any such issue by requiring the recited components to “receive and process data from . . . messages received via a device link agent.” *Id.* This shows the “software components” and “device link agent” are different things that perform different functions. *Id.*

Samsung’s position is similar to its arguments on the agents-or-apps question discussed *supra*, and is unpersuasive for the same reasons. Although “software components” and “device link agents” are distinct claim elements, at most there is a presumption that Headwater cannot point to the same software as satisfying both the “software components” and “device link agents” requirements of the claims to prove infringement. *See Becton, Dickinson & Co.*, 616 F.3d at 1254 (“Where a claim lists elements separately, ‘the clear implication of the claim language’ is that those elements are ‘distinct component[s]’ of the patented invention.” (quoting *Gaus*, 363 F.3d at 1288)). But that does not by itself require mutual exclusivity *between the scope* of the two terms. Here, Samsung’s expert recognizes the ordinary meaning of “software components” as “components of software,” Turnbull Decl., Dkt. No. 94-7 ¶ 44 (“Ordinarily, the term ‘software components’ would be understood to refer to some component of software . . .”), which the Court adopts as its

construction: “components of software.”

E. “wherein one of the message delivery triggers is the receipt of a particular network element message from one of the network elements” (’192 Patent, Claim 13)

Headwater’s Construction	Samsung’s Construction
No construction necessary; plain and ordinary meaning	Indefinite

This dispute focuses on “particular network element message” and, more specifically, on the impact of “particular.” Samsung wonders, for example, “[i]s a message ‘particular’ because it contains certain content, or because it arrives at a particular time or in a particular manner[?]” Dkt. No. 96 at 25. Headwater replies this is a breadth issue rather than one of indefiniteness. Dkt. No. 99 at 10. It also notes Samsung’s expert’s testimony that a skilled artisan would understand the scope of the term as “not any network element message, [but] a particular type of one or a particular one.” Dkt. No. 99 at 10 (quoting Turnbull Depo. Tr., Dkt. No. 94-8 at 128:12–25).

The Court agrees with Headwater. A skilled artisan would understand the claim’s use of “particular” to differentiate the phrase from merely the *receipt* of *any* message. This aligns with the language of Claim 1, the Abstract, and Samsung’s expert’s understanding of the term that it is “not any network element message.” *See* ’192 Patent at [57] (noting messages “may be buffered until the occurrence of a trigger *other than the receipt of that message by the server*” (emphasis added)), 167:34–35 (reciting, in Claim 1, “the receipt of such a message by the message buffer system is not a message delivery trigger”). In other words, a characteristic of the message is what matters, not the receipt of the message itself. But the claim is broad enough to include many types of characteristics, including the message’s content, arrival time, or manner of arrival. Given that, the Court holds this term is not indefinite and should have a “plain and ordinary meaning”

construction.

V. CONCLUSION

Disputed Term	The Court's Construction
“device agents” (’733 Patent, Claims 1, 30)	“a piece of software on the end-user device that performs certain functions for other software”
“wherein the particular device agent is configured to assist in presenting a notification through the user interface, the notification based on message content” (’337 Patent, Claim 19)	Plain and ordinary meaning
“device messaging agent” (’117 Patent, Claim 1)	“a piece of software on a mobile end-user device that performs certain messaging functions for other software”
“software components” (’192 Patent, Claims 1, 4, 15)	“components of software”
“wherein one of the message delivery triggers is the receipt of a particular network element message from one of the network elements” (’192 Patent, Claim 13)	Plain and ordinary meaning

The Court **ORDERS** each party not to refer, directly or indirectly, to its own or any other party’s claim-construction positions in the presence of the jury. Likewise, the Court **ORDERS** the parties to refrain from mentioning any part of this opinion, other than the actual positions adopted by the Court, in the presence of the jury. Neither party may take a position before the jury that contradicts the Court’s reasoning in this opinion. Any reference to claim construction proceedings is limited to informing the jury of the positions adopted by the Court.

SIGNED this 22nd day of August, 2024.

ROY S. PAYNE
UNITED STATES MAGISTRATE JUDGE