



US007902648B2

(12) **United States Patent**  
**Lee**

(10) **Patent No.:** **US 7,902,648 B2**  
(45) **Date of Patent:** **Mar. 8, 2011**

(54) **INTERPOSER CONFIGURED TO REDUCE THE PROFILES OF SEMICONDUCTOR DEVICE ASSEMBLIES, PACKAGES INCLUDING THE SAME, AND METHODS**

(75) Inventor: **Teck Kheng Lee**, Singapore (SG)

(73) Assignee: **Micron Technology, Inc.**, Boise, ID (US)

(\* ) Notice: Subject to any disclaimer, the term of this patent is extended or adjusted under 35 U.S.C. 154(b) by 295 days.

(21) Appl. No.: **11/398,912**

(22) Filed: **Apr. 6, 2006**

(65) **Prior Publication Data**

US 2006/0175690 A1 Aug. 10, 2006

**Related U.S. Application Data**

(63) Continuation of application No. 10/150,893, filed on May 17, 2002, now Pat. No. 7,145,225.

(30) **Foreign Application Priority Data**

Mar. 4, 2002 (SG) ..... 200201263-1

(51) **Int. Cl.**  
**H01L 23/495** (2006.01)

(52) **U.S. Cl.** ..... **257/676; 257/E23.037; 257/E23.069; 257/E23.092; 257/E23.105; 257/E23.013; 257/E25.023; 257/778; 257/737; 257/774; 257/773; 257/784; 257/786; 257/684; 257/796**

(58) **Field of Classification Search** ..... **257/676, 257/E23.037, E23.069, E23.092, E23.105, 257/E25.013, E23.023, 778, 737, 734, 738, 257/774, 773, 784, 786, 684, 796**

See application file for complete search history.

(56) **References Cited**

**U.S. PATENT DOCUMENTS**

3,239,496 A	3/1966	Jursich
4,074,342 A	2/1978	Honn et al.
4,807,021 A	2/1989	Okumura
4,818,728 A	4/1989	Rai et al.
4,954,875 A	9/1990	Clements

**FOREIGN PATENT DOCUMENTS**

EP 0475022 A1 3/1992

(Continued)

**OTHER PUBLICATIONS**

Xiao et al., "Reliability Study and Failure Analysis of Fine Pitch Solder-Bumped Flip Chip on Low-Cost Flexible Substrate without Using Stiffener," IEEE, 2002. Proceedings, 52nd, Electronic Components and Technology Conference, pp. 112-118 (2002).

(Continued)

*Primary Examiner*—Alexander O Williams

(74) *Attorney, Agent, or Firm*—TraskBritt

(57) **ABSTRACT**

An interposer includes a substrate, a conductive structure configured to contact the back side of a semiconductor device and contact pads. The interposer may include first and second sets of contact pads carried by the substrate. The interposer may also include conductive traces carried by the substrate to electrically connect corresponding contact pads of the first and second sets. The receptacles, which may be formed in a surface of the substrate and expose contacts of the second set, may be configured to at least partially receive conductive structures that are secured to the contact pads of the second set. Thus, the interposer may be useful in providing semiconductor device assemblies and packages of reduced height or profile. Such assemblies and packages are also described, as are multi-chip modules including such assemblies or packages. In addition, methods for designing and fabricating the interposer are disclosed, as are methods for forming assemblies, packages, and multi-chip modules that include the interposer.

**46 Claims, 6 Drawing Sheets**

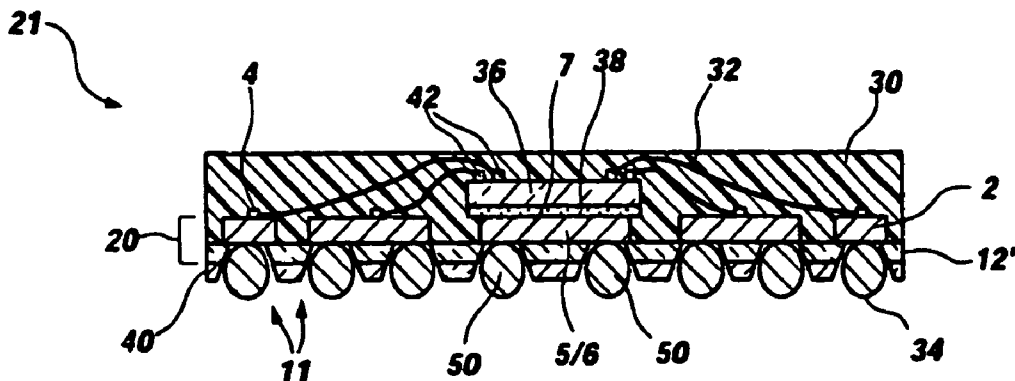

U.S. PATENT DOCUMENTS					
5,148,265 A	9/1992	Khandros	6,008,543 A	12/1999	Iwabuchi
5,258,648 A	11/1993	Lin	6,011,694 A	1/2000	Hirakawa
5,346,861 A	9/1994	Khandros	6,013,948 A	1/2000	Akram et al.
5,347,159 A	9/1994	Khandros et al.	6,020,629 A	2/2000	Farnworth et al.
5,366,794 A	11/1994	Nakao	6,022,761 A	2/2000	Gruppen-Shemansky et al.
5,385,869 A	1/1995	Liu et al.	6,024,584 A	2/2000	Lemke et al.
5,386,341 A	1/1995	Olson et al.	6,027,346 A	2/2000	Sinsheimer et al.
5,394,303 A	2/1995	Yamaji	6,028,365 A	2/2000	Akram et al.
5,397,921 A	3/1995	Karnezos	6,034,427 A	3/2000	Lan et al.
5,404,044 A	4/1995	Booth et al.	6,037,665 A	3/2000	Miyazaki
5,409,865 A	4/1995	Karnezos	6,039,889 A	3/2000	Zhang et al.
5,422,205 A	6/1995	Inoue et al.	6,040,630 A	3/2000	Panchou et al.
5,422,615 A *	6/1995	Shibagaki et al. .... 333/246	6,048,755 A	4/2000	Jiang et al.
5,438,477 A	8/1995	Pasch	6,050,832 A	4/2000	Lee et al.
5,448,511 A	9/1995	Paurus et al.	6,057,178 A	5/2000	Galuschki et al.
5,468,681 A	11/1995	Pasch	6,060,782 A	5/2000	Ohsono et al.
5,468,995 A	11/1995	Higgins, III	6,064,114 A	5/2000	Higgins, III
5,489,804 A	2/1996	Pasch	6,072,233 A	6/2000	Corisis et al.
5,504,277 A	4/1996	Danner	6,074,897 A	6/2000	Degani et al.
5,598,033 A	1/1997	Behlen et al.	6,075,710 A	6/2000	Lau
5,608,265 A *	3/1997	Kitano et al. .... 257/738	6,079,991 A	6/2000	Lemke et al.
5,646,446 A	7/1997	Nicewarner, Jr. et al.	6,093,035 A	7/2000	Lemke et al.
5,663,530 A	9/1997	Schueller et al.	6,116,921 A	9/2000	Scholz et al.
5,668,405 A	9/1997	Yamashita	6,124,631 A	9/2000	Cardot et al.
5,674,785 A	10/1997	Akram et al.	6,127,736 A	10/2000	Akram
5,679,977 A	10/1997	Khandros	6,133,072 A	10/2000	Fjelstad
5,683,942 A	11/1997	Kata	6,133,637 A	10/2000	Hikita et al.
5,697,148 A	12/1997	Lance, Jr. et al.	6,137,062 A	10/2000	Zimmerman
5,699,027 A *	12/1997	Tsuji et al. .... 333/193	6,137,164 A	10/2000	Yew et al.
5,710,071 A	1/1998	Beddingfield et al.	6,137,183 A	10/2000	Sako
5,719,449 A	2/1998	Strauss	6,157,541 A	12/2000	Hacke
5,721,151 A	2/1998	Padmanabhan et al.	6,165,885 A	12/2000	Gaynes et al.
5,723,347 A	3/1998	Hirano et al.	6,172,422 B1	1/2001	Chigawa et al.
5,739,585 A	4/1998	Akram et al.	6,177,723 B1	1/2001	Eng et al.
5,742,100 A	4/1998	Schroeder et al.	6,179,598 B1	1/2001	Brand
5,747,982 A	5/1998	Dromgoole et al.	6,180,881 B1	1/2001	Isaak
5,752,182 A	5/1998	Nakatsuka et al.	6,191,487 B1	2/2001	Rodenbeck et al.
5,758,413 A	6/1998	Chong et al.	6,198,634 B1	3/2001	Armezzani et al.
5,768,109 A	6/1998	Gulick et al.	6,208,521 B1	3/2001	Nakatsuka
5,776,797 A	7/1998	Nicewarner, Jr. et al.	6,208,525 B1	3/2001	Imasu et al.
5,777,391 A	7/1998	Nakamura	6,212,768 B1	4/2001	Murakami
5,796,591 A	8/1998	Dalal et al.	6,214,156 B1	4/2001	Takano et al.
5,798,285 A	8/1998	Bentlage et al.	6,217,343 B1	4/2001	Okuno
5,798,567 A	8/1998	Kelly et al.	6,218,202 B1	4/2001	Yew et al.
5,805,422 A	9/1998	Otake et al.	6,219,911 B1	4/2001	Estes et al.
5,812,378 A	9/1998	Fjelstad et al.	6,221,763 B1	4/2001	Gilton et al.
5,818,113 A	10/1998	Iseki et al.	6,222,265 B1	4/2001	Akram et al.
5,821,624 A	10/1998	Pasch	6,225,688 B1	5/2001	Kim et al.
5,834,338 A	11/1998	Takeda et al.	6,229,711 B1	5/2001	Yoneda
5,834,366 A	11/1998	Akram	6,232,666 B1	5/2001	Corisis et al.
5,834,848 A	11/1998	Iwasaki	6,239,496 B1	5/2001	Asada
5,835,355 A	11/1998	Dordi	6,242,932 B1	6/2001	Hembree
5,843,808 A	12/1998	Karnezos	6,262,895 B1	7/2001	Forthun
5,844,168 A	12/1998	Schueller et al.	6,265,775 B1	7/2001	Seyyedy
5,844,315 A	12/1998	Melton et al.	6,268,654 B1 *	7/2001	Glenn et al. .... 257/704
5,866,953 A	2/1999	Akram et al.	6,271,469 B1	8/2001	Ma et al.
5,877,559 A	3/1999	Takayama et al.	6,281,046 B1	8/2001	Lam
5,886,408 A	3/1999	Ohki et al.	6,282,094 B1 *	8/2001	Lo et al. .... 361/704
5,891,753 A	4/1999	Akram	6,285,081 B1	9/2001	Jackson
5,892,271 A	4/1999	Takeda et al.	6,291,265 B1	9/2001	Mess
5,898,224 A	4/1999	Akram	6,291,775 B1	9/2001	Saitoh
5,905,303 A	5/1999	Kata	6,291,884 B1	9/2001	Glenn et al.
5,973,389 A	10/1999	Culnane et al.	6,294,455 B1	9/2001	Ahn
5,973,404 A	10/1999	Akram et al.	6,295,730 B1	10/2001	Akram
5,977,640 A	11/1999	Bertin et al.	6,300,679 B1	10/2001	Mukerji et al.
5,982,030 A	11/1999	MacIntrye	6,310,288 B1	10/2001	Moden
5,984,691 A	11/1999	Brodsky et al.	6,323,060 B1	11/2001	Isaak
5,986,460 A	11/1999	Kawakami	6,338,985 B1	1/2002	Greenwood
5,990,545 A	11/1999	Schueller et al.	6,376,769 B1	4/2002	Chung
5,991,161 A	11/1999	Samaras et al.	6,404,648 B1	6/2002	Slupe et al.
6,005,776 A	12/1999	Holman et al.	6,407,450 B1	6/2002	Verma et al.
			6,413,102 B2	7/2002	Jiang et al.
			6,429,516 B1	8/2002	Tsunoi

6,432,737	B1	8/2002	Webster	
6,449,840	B1	9/2002	Le et al.	
6,452,807	B1	9/2002	Barrett	
6,468,831	B2	10/2002	Leong et al.	
6,482,676	B2	11/2002	Tsunoi et al.	
6,486,544	B1	11/2002	Hashimoto	
6,489,676	B2*	12/2002	Taniguchi et al.	257/698
6,489,687	B1	12/2002	Hashimoto	
6,492,737	B1	12/2002	Imasu et al.	
6,504,241	B1	1/2003	Yanagida	
6,507,118	B1	1/2003	Schueller	
6,515,324	B2	2/2003	Shibuya et al.	
6,518,677	B1	2/2003	Capote et al.	
6,534,853	B2	3/2003	Liu et al.	
6,552,910	B1	4/2003	Moon et al.	
6,558,978	B1	5/2003	McCormick	
6,563,223	B2	5/2003	Freeman	
6,586,830	B2	7/2003	Saito	
6,600,222	B1	7/2003	Levardo	
6,610,559	B2	8/2003	Wang et al.	
6,700,208	B1	3/2004	Yoneda	
6,714,418	B2	3/2004	Frankowsky et al.	
6,730,855	B2	5/2004	Bando	
6,744,122	B1	6/2004	Hashimoto	
6,756,251	B2	6/2004	Lee	
6,780,746	B2	8/2004	Kinsman et al.	
6,787,918	B1	9/2004	Tsai et al.	
6,791,195	B2*	9/2004	Urushima	257/783
6,800,930	B2	10/2004	Jackson et al.	
6,847,105	B2	1/2005	Koopmans	
6,867,496	B1	3/2005	Hashimoto	
7,145,225	B2*	12/2006	Lee	257/686
7,298,043	B2*	11/2007	Yui	257/713
7,347,702	B2	3/2008	Eldridge et al.	
2001/0024129	A1	9/2001	Akram et al.	
2001/0048157	A1	12/2001	Murtuza	
2001/0053563	A1	12/2001	Kim et al.	
2002/0045611	A1	4/2002	Abrams et al.	
2002/0079594	A1	6/2002	Sakurai	
2002/0127769	A1	9/2002	Ma et al.	
2002/0142513	A1	10/2002	Fee et al.	
2002/0167092	A1	11/2002	Fee et al.	
2002/0185661	A1	12/2002	Kawanobe et al.	
2003/0012930	A1	1/2003	Brousseau, III	
2003/0042595	A1	3/2003	Canella	
2003/0134450	A1	7/2003	Lee	
2003/0164543	A1*	9/2003	Kheng Lee	257/706
2003/0178719	A1*	9/2003	Combs et al.	257/704
2003/0209813	A1*	11/2003	Azuma	257/797
2004/0026773	A1	2/2004	Koon et al.	
2004/0130020	A1*	7/2004	Kuwabara et al.	257/723
2004/0197955	A1*	10/2004	Lee	438/108
2004/0212055	A1	10/2004	Exposito et al.	
2004/0217454	A1	11/2004	Brechignac et al.	
2005/0073039	A1*	4/2005	Kasuya et al.	257/690
2005/0122265	A1*	6/2005	Gaucher et al.	343/700 MS
2005/0133906	A1*	6/2005	Woodall et al.	257/707
2006/0065972	A1*	3/2006	Khan et al.	257/712
2006/0091523	A1*	5/2006	Shimanuki	257/698
2006/0289989	A1*	12/2006	Yee et al.	257/720
2008/0083981	A1*	4/2008	Romig et al.	257/707
2008/0178463	A1*	7/2008	Okubora	29/830
2009/0115050	A1*	5/2009	Kasuya et al.	257/701

FOREIGN PATENT DOCUMENTS

EP	684644	11/1995
EP	0997942 A2	5/2000
EP	1009027	6/2000
JP	04030456	2/1992
JP	9-82857	* 3/1997
JP	2002-028702/04	9/1999
JP	2000-183082	6/2000

JP	02000230964	8/2000
JP	2001077294	3/2001
KR	2001054744	7/2001
KR	20010058357	7/2001
WO	WO 99/65282	12/1999
WO	WO 01/33623	5/2001

OTHER PUBLICATIONS

Xiao et al., "Reliability Study and Failure Analysis of Fine Pitch Solder Bumped Flip Chip on Low-Cost Printed Circuit Board Substrate," *IEEE*, 2001, Proceedings, 51<sup>st</sup>, Electronic Components and Technology Conference, 8 pages (2001).

Australian Patent Office Search Report, May 30, 2003; 4 pages.

Australian Search Report dated Aug. 11, 2004 (3 pages).

Australian Search Report dated Aug. 16, 2004 (4 pages).

Al-Sarawi et al., "A review of 3-D packaging technology," *Components, Packaging, and Manufacturing Technology, Part B: IEEE Transactions on Advanced Packaging*, vol. 21, Issue 1, Feb. 1998, pp. 2-14.

Andros et al., "TBGA Package Technology," *Components, Packaging, and Manufacturing Technology, Part B: IEEE Transactions on Advanced Packaging*, vol. 17, Issue 4, Nov. 1994, pp. 564-568.

Clot et al., "Flip-Chip on Flex for 3D Packaging," 1999. *24<sup>th</sup> IEEE/CPMT*, Oct. 18-19, 1999, pp. 36-41.

Ferrando et al., "Industrial approach of a flip-chip method using the stud-bumps with a non-conductive paste," *Adhesive Joining and Coating Technology in Electronics Manufacturing*, 2000. Proceedings. 4<sup>th</sup> International Conference on, Jun. 18-21, 2000, pp. 205-211.

Gallagher et al., "A Fully Additive, Polymeric Process for the Fabrication and Assembly of Substrate and Component Level Packaging," *The First IEEE International Symposium on Polymeric Electronics Packaging*, Oct. 26-30, 1997, pp. 56-63.

Geissinger et al., "Tape Based CSP Package Supports Fine Pitch Wirebonding," *Electronics Manufacturing Technology Symposium*, 2002, IEMT 2002, 27<sup>th</sup> Annual IEEE/SEMI International, Jul. 17-18, 2002, pp. 41-452.

Hatanaka, H., "Packaging processes using flip chip bonder and future directions of technology development," *Electronics Packaging Technology Conference*, 2002. 4<sup>th</sup>, Dec. 10-12, 2002, pp. 434-439.

Haug et al., "Low-Cost Direct Chip Attach: Comparison of SMD Compatible FC Soldering with Anisotropically Conductive Adhesive FC Bonding," *IEEE Transactions on Electronics Packaging Manufacturing*, vol. 23, No. 1, Jan. 2000, pp. 12-18.

Isaak, H. et al., "Development of Flex Stackable Carriers" *IEEE Electronic Components and Technology Conference*, 2000 Proceedings 50<sup>th</sup>, May 21, 2000-May 24, 2000, Las Vegas, NV, USA, pp. 378-384, IEEE Catalog No: 00CH37070.

Kloeser et al., "Fine Pitch Stencil Printing of Sn/Pb and Lead Free Solders for Flip Chip Technology," *IEEE Transactions of CPMT—Part C*, vol. 21, No. 1, 1998, pp. 41-49.

Lee et al., "Enhancement of Moisture Sensitivity Performance of a FBGA," *Proceedings of International Symposium on Electronic Materials & Packaging*, 2000, pp. 470-475.

Li et al., "Stencil Printing Process Development for Flip Chip Interconnect," *IEEE Transactions Part C: Electronics Packaging Manufacturing*, vol. 23 Issue 3. (Jul. 2000), pp. 165-170.

Lyons et al., "A New Approach to Using Anisotropically Conductive Adhesives for Flip-Chip Assembly. Part A," *IEEE Transactions on Components, Packaging, and Manufacturing Technology*, vol. 19, Issue 1, Mar. 1996, pp. 5-11.

Teo et al., "Enhancing Moisture Resistance of PBGA," *Electronic Components and Technology Conference*, 1988. 48<sup>th</sup> IEEE, May 25-28, 1998, pp. 930-935.

Teutsch et al., "Wafer Level CSP using Low Cost Electroless Redistribution Layer," *Electronic Components and Technology Conference*, 2000 Proceedings. 50<sup>th</sup>, May 21-24, 2000, pp. 107-113.

"The 2003 International Technology Roadmap for Semiconductor: Assembly and Packaging."

Tsui et al., "Pad redistribution technology for flip chip applications," *Electronic Components and Technology Conference*, 1998. 48<sup>th</sup> IEEE, May 25-28, 1998, pp. 1098-1102.

Xiao et al., "Reliability study and failure analysis of fine pitch solder-bumped flip chip on low-cost flexible substrate without using stiffener," *IEEE*, 2002. Proceedings 52<sup>nd</sup>, May 28-31, 2002, pp. 112-118.

\* cited by examiner

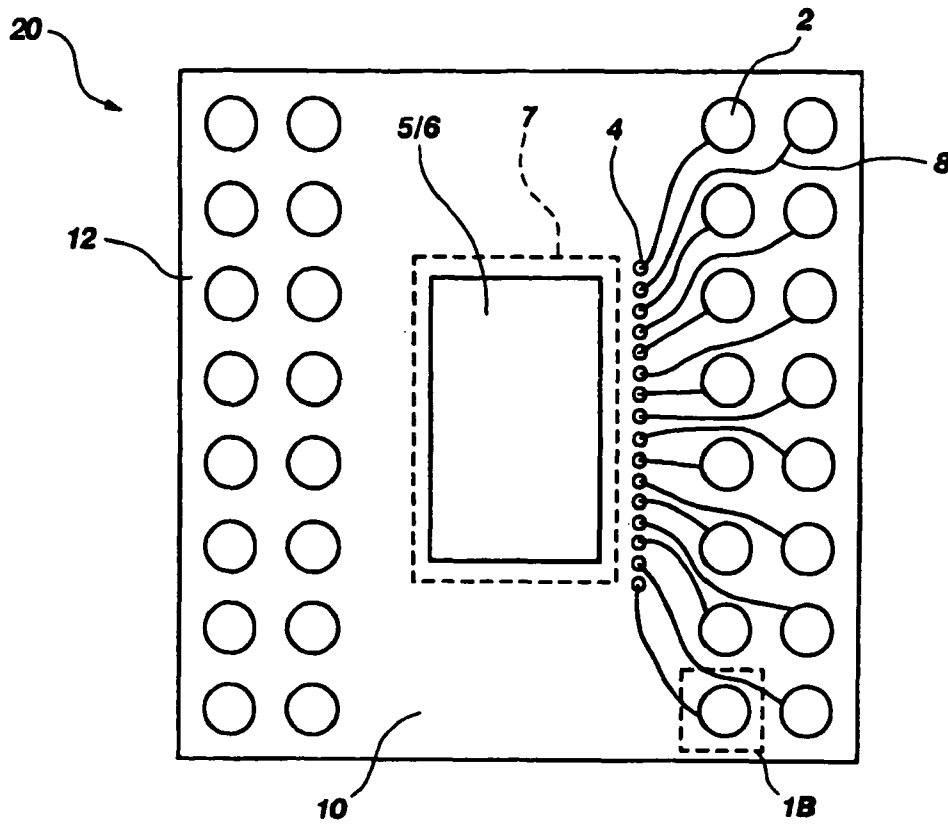

Fig. 1A

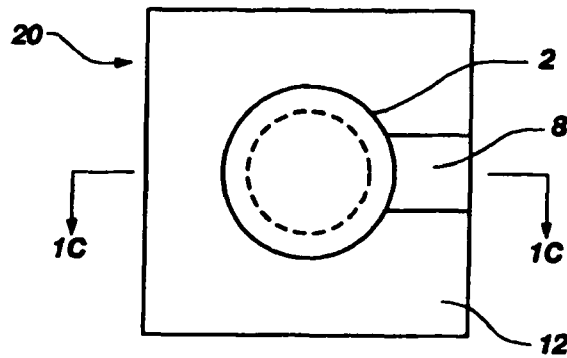

Fig. 1B

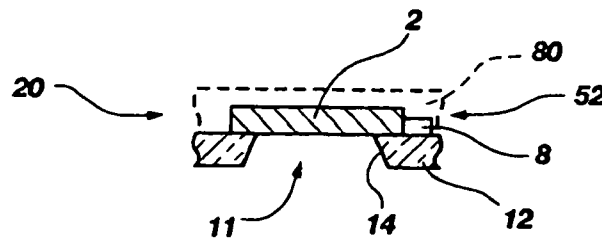

Fig. 1C

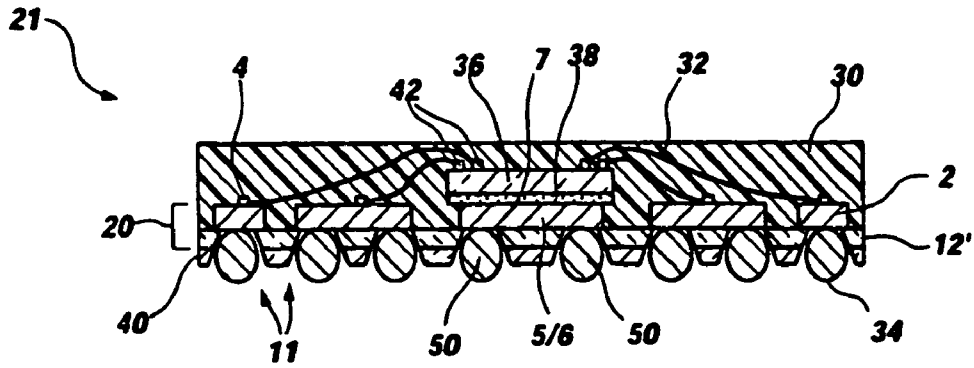

Fig. 2A

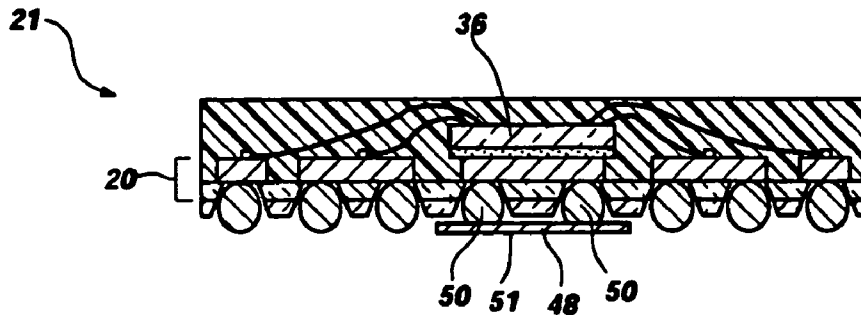

Fig. 2B

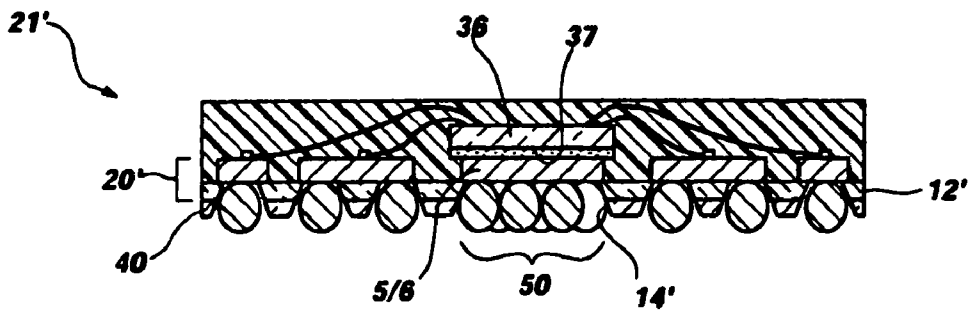

Fig. 2D

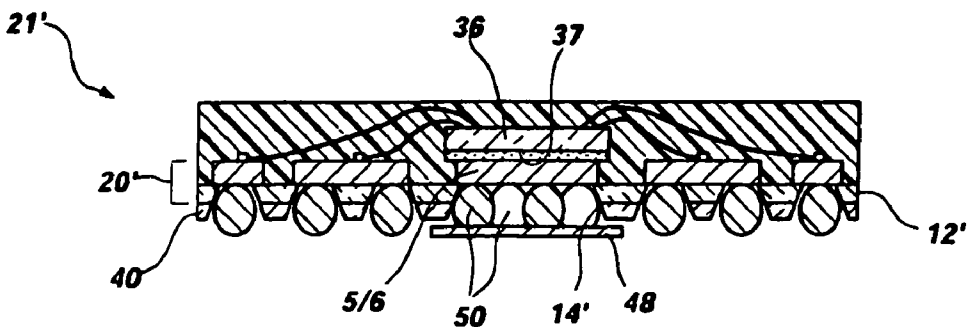

Fig. 2E

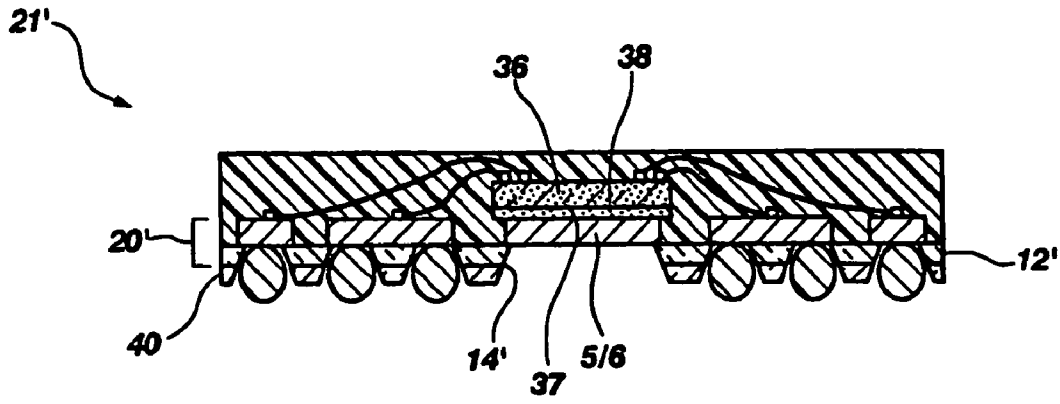

Fig. 2C

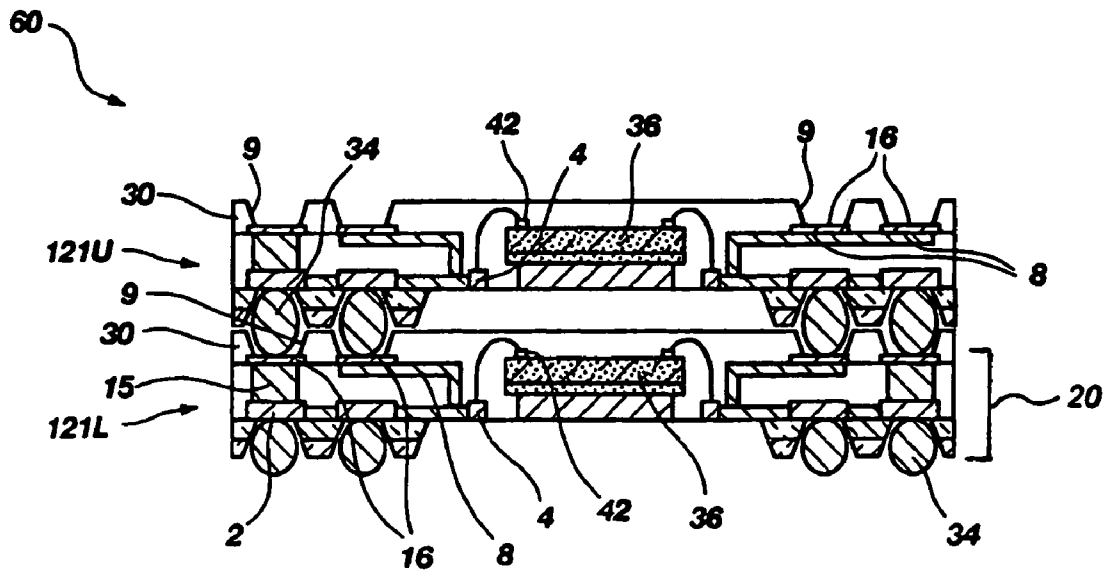
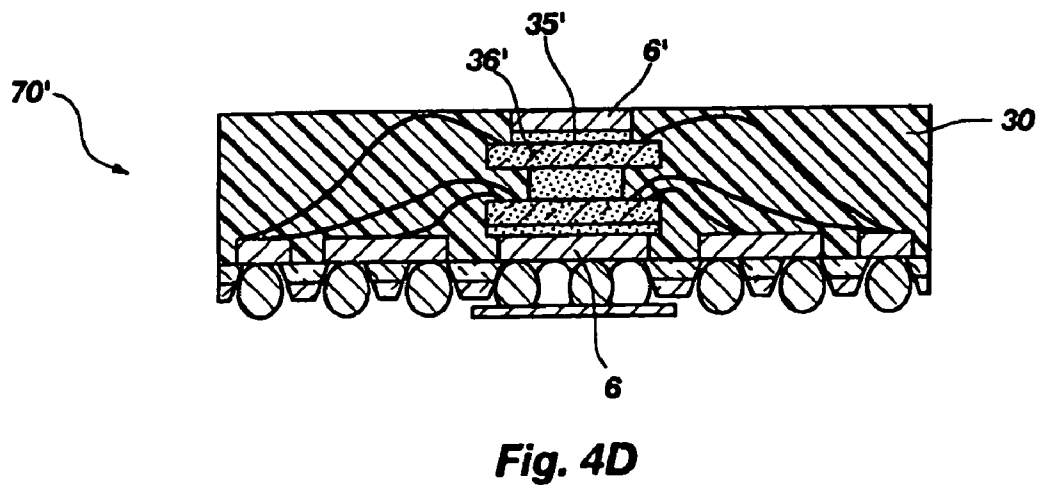
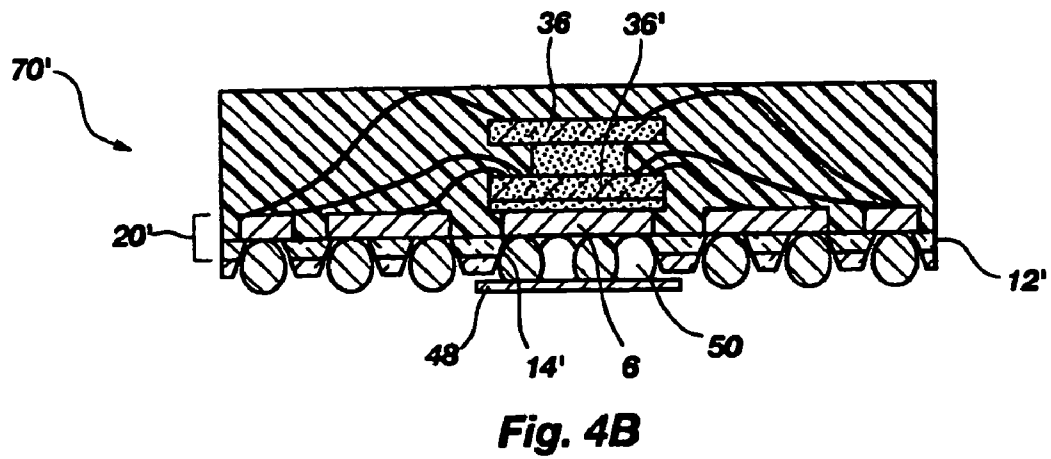
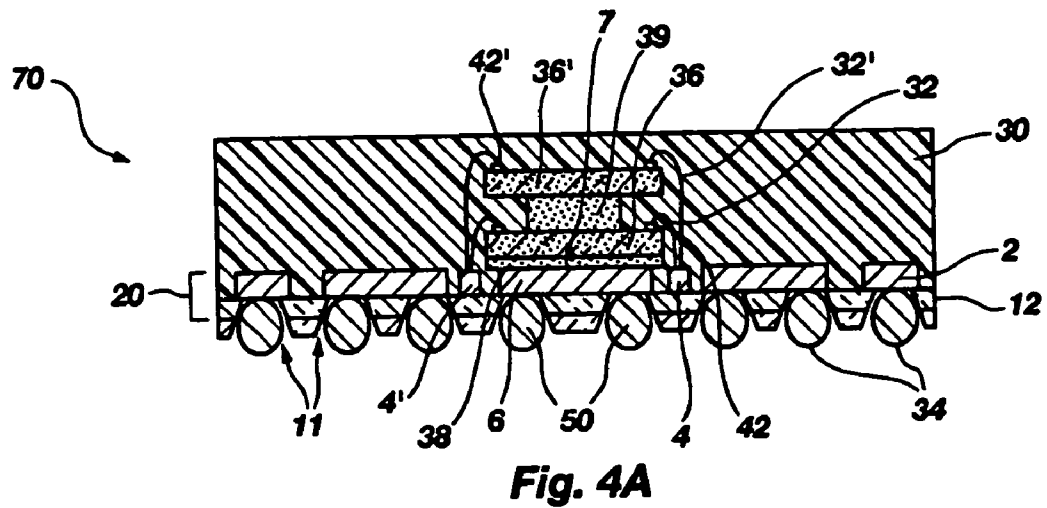
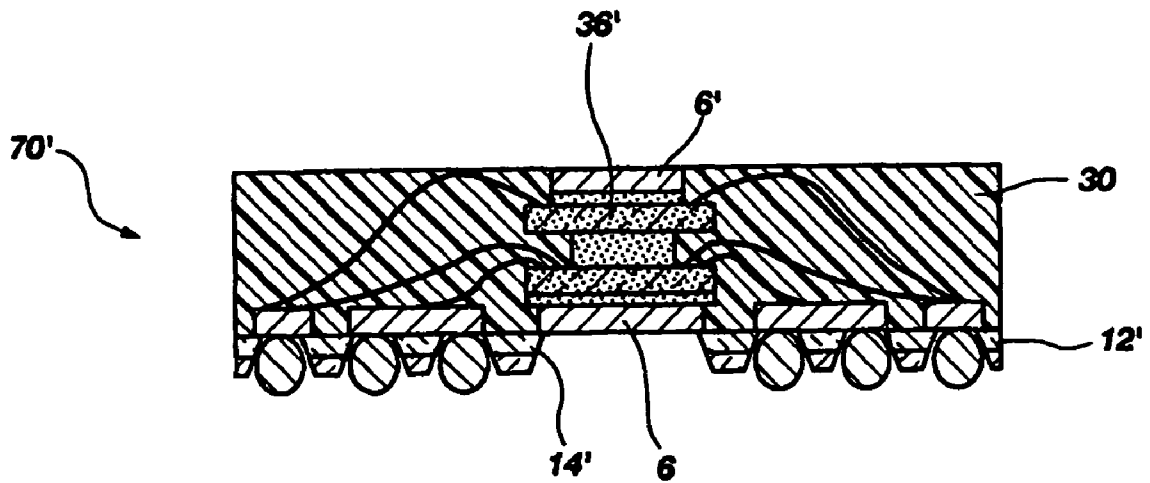

Fig. 3





**Fig. 4C**

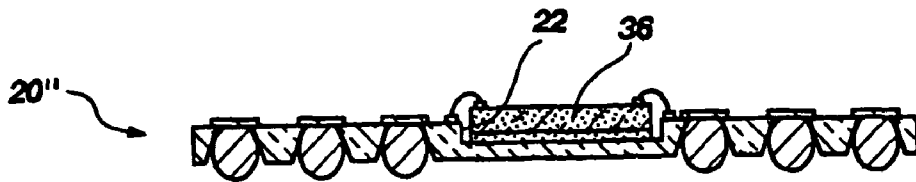

Fig. 5

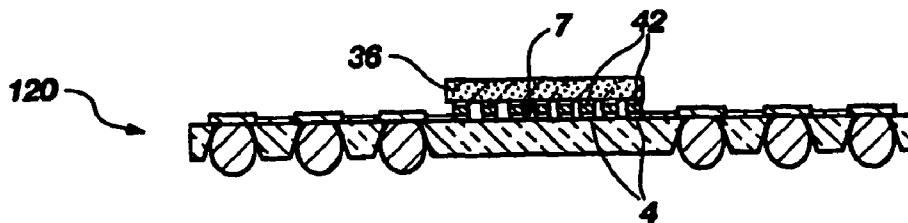

Fig. 6

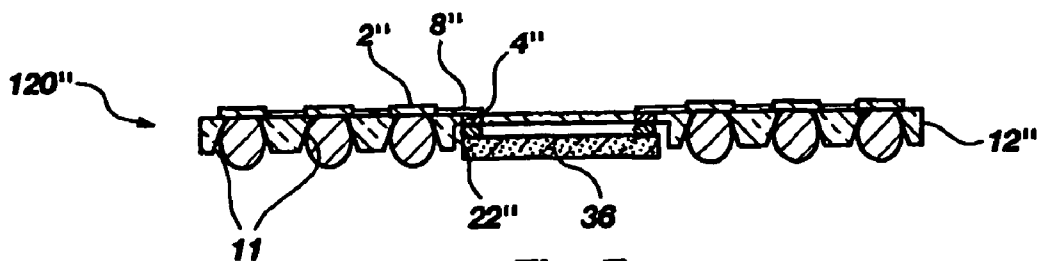

Fig. 7

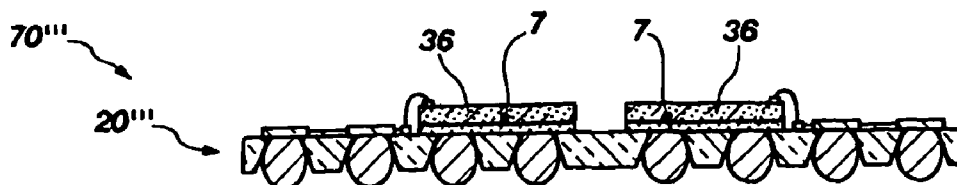

Fig. 8

**INTERPOSER CONFIGURED TO REDUCE  
THE PROFILES OF SEMICONDUCTOR  
DEVICE ASSEMBLIES, PACKAGES  
INCLUDING THE SAME, AND METHODS**

CROSS-REFERENCE TO RELATED  
APPLICATIONS

This application is a continuation of application Ser. No. 10/150,893, filed May 17, 2002, now U.S. Pat. No. 7,145,225 B2, issued Dec. 5, 2006, which is related to U.S. patent application Ser. No. 09/944,465, filed Aug. 30, 2001, and titled MICROELECTRONIC DEVICES AND METHODS OF MANUFACTURE; now U.S. Pat. No. 6,756,251, issued Jun. 29, 2004, and to the following U.S. Patent Applications filed on even date herewith: Ser. No. 10/150,892, filed May 17, 2002, and titled METHOD AND APPARATUS FOR FLIP-CHIP PACKAGING PROVIDING TESTING CAPABILITY, pending; Ser. No. 10/150,516, filed May 17, 2002, and titled SEMICONDUCTOR DIE PACKAGES WITH RECESSED INTERCONNECTING STRUCTURES AND METHODS FOR ASSEMBLING THE SAME, now U.S. Pat. No. 7,112,520, issued Sep. 26, 2006; Ser. No. 10/150,653, filed May 17, 2002, and entitled FLIP CHIP PACKAGING USING RECESSED INTERPOSER TERMINALS, now U.S. Pat. No. 7,161,237, issued Jan. 9, 2007; Ser. No. 10/150,902, filed May 17, 2002, and entitled METHOD AND APPARATUS FOR DIELECTRIC FILLING OF FLIP CHIP ON INTERPOSER ASSEMBLY, now U.S. Pat. No. 6,975,035, issued Dec. 13, 2005; and Ser. No. 10/150,901, filed May 17, 2002, and entitled METHODS FOR ASSEMBLY AND PACKAGING OF FLIP CHIP CONFIGURED DICE WITH INTERPOSER, now U.S. Pat. No. 7,348,215, issued Mar. 25, 2008.

BACKGROUND OF THE INVENTION

1. Field of the Invention

The present invention relates to interposers for packaging semiconductor devices with array-type connection patterns. In particular, the present invention relates to tape-type interposers that are useful in semiconductor device assemblies and packages of reduced package height, or profile, and to semiconductor device assemblies and packages of reduced profile. The present invention also relates to methods for fabricating the tape-type interposers and to methods for forming semiconductor device assemblies and packages that include the tape-type interposers.

2. State of the Art

Conventionally, semiconductor dice have been packaged in plastic or, less commonly, in ceramic packages. Packages may support, protect, and dissipate heat from semiconductor dice. Packages may also provide external connective elements for providing power and signal distribution to and from semiconductor dice, as well as for facilitating electrical testing, such as burn-in testing and circuit evaluation, of semiconductor dice prior to or after assembly thereof with higher-level components, such as carrier substrates or circuit boards.

The ever-decreasing sizes of electronic devices, such as cellular telephones, handheld computers, and portable computers, have driven the need for semiconductor device assemblies and packages with ever-decreasing profiles, as well as the need for semiconductor device assemblies and packages that consume ever-decreasing amounts of the surface areas, or "real estate", of carrier substrates, such as circuit boards.

The need for semiconductor device assemblies and packages that consume ever-decreasing amounts of real estate has

been met by use of external connection technologies, such as so-called "flip-chip" connections, in which a semiconductor device is positioned over a carrier therefore in an inverted orientation with contact pads (e.g., bond pads of a bare semiconductor die or contacts of a semiconductor device assembly or package) of the semiconductor device and corresponding terminal pads of the carrier in alignment with one another. Flip-chip type connections provide the desired number of connections to a semiconductor device without requiring that an assembly or package that includes the semiconductor device have peripheral edges that extend a substantial distance beyond the peripheral edges of the semiconductor device. This type of semiconductor device assembly or package is typically referred to as a "grid array" package (e.g., a ball grid array (BGA) package or pin grid array (PGA) package) due to the arrangement of input and output contacts thereof in a grid array connection pattern. Such contact pad arrangements facilitate the use of a greater number of connections than would otherwise be possible when contact pads are arranged only along the periphery of an interposer.

Grid array semiconductor device assemblies and packages typically include an interposer to which one or more semiconductor dice may be secured and electrically connected. A substrate of the interposer may be formed from a variety of different, typically electrically insulative or insulator-coated materials, including flexible materials, such as polymer (e.g., polyimide) films or tapes, and rigid materials, such as silicon, glass, ceramic, or organic materials (e.g., FR-4 resin).

Interposers for use in grid array assemblies and packages also typically include conductive traces that extend between first and second sets of contacts, with each of the foregoing being carried by the interposer substrate. Contacts of a first set are electrically connectable to corresponding bond pads of a semiconductor die. Contacts of a second set are configured for making external electrical connections to other electronic components, such as circuit boards or other semiconductor devices. When the first and second sets of contacts are on opposite sides of the interposer, conductive vias may be positioned along one or more conductive traces to facilitate communication between contact pads of the first set and their corresponding contact pads of the second set. The first and second sets of contact pads are arranged in such a way as to redistribute the locations of the bond pads of a semiconductor device secured to the interposer. Such redistribution may provide for a contact pad arrangement that is more desirable than the arrangement of bond pads on the semiconductor device, for a contact pad that is more useful than the bond pad arrangement in flip-chip applications, for increased spacing or pitch between adjacent contact pads relative to that between corresponding, adjacent bond pads of the semiconductor device, or some combination of these features.

When such an interposer is assembled with a semiconductor device, the contact pads of the first group are typically connected to corresponding bond pads of the semiconductor device by way of discrete conductive elements, such as bond wires, conductive tape-automated bond (TAB) elements carried upon a flexible, dielectric substrate, or by so-called "flip-chip" bonding techniques, which employ conductive structures such as balls, bumps, columns, or other structures formed from conductive material, such as metal, metal alloy (e.g., solder), conductive or conductor-filled polymer, anisotropically (i.e., z-axis) conductive elastomer, or the like.

An interposer-semiconductor device assembly may communicate with electronic components external thereto by way of external conductive elements, such as conductive balls, bumps, columns, pins, or other structures, that extend from contact pads of the second set. When solder balls are

employed, the connection pattern of such a semiconductor device assembly is termed a “ball grid array” (BGA) connection pattern or a “fine ball grid array” (FBGA) connection pattern, depending upon the spacing or pitch between adjacent solder balls. Similarly, when pins are used as the external conductive elements of such an assembly, the connection pattern of the assembly may be referred to as a “pin grid array” (PGA) connection pattern.

Conventionally, the thicknesses of such assemblies are defined by the cumulative thicknesses of the interposer, the adhesive material securing a semiconductor device thereto, the semiconductor device, the distance bond wires protrude above an active surface of the semiconductor device, and the distance external conductive elements extend from the interposer.

Several interposer designs have been developed to address the need for semiconductor device assemblies and packages of ever-decreasing profiles. For example, some rigid interposers include recesses for receiving all or part of a semiconductor device. The recesses of such interposers may also be configured to receive all or part of the discrete conductive elements (e.g., bond wires) that electrically connect bond pads of a semiconductor device to corresponding contact pads of the interposer. The profiles of grid array-type assemblies or packages including such interposers are typically defined by a combination of the thickness of the interposer, the distance that discrete conductive elements protrude above a surface of the interposer, and the height of conductive structures protruding from an opposite surface of the interposer. While these grid array packages are thinner than their predecessors by an amount equal to the full or partial thicknesses of the semiconductor devices and adhesive layers thereof, it is difficult, if not impossible, to further decrease their profiles.

Accordingly, there are needs for semiconductor device assemblies and packages having reduced profiles, as well as for an interposer configured to impart an assembly or package including the same with a thinner profile.

#### BRIEF SUMMARY OF THE INVENTION

The present invention includes an interposer that may be used in semiconductor device assemblies and packages to impart such assemblies or packages with relatively thin profiles. In addition, the present invention includes flip-chip type semiconductor device assemblies and packages that include such interposers. The present invention also includes methods for fabricating the inventive interposers.

An interposer incorporating teachings of the present invention includes a thin substrate with at least one attach region. Each attach region of the interposer is configured to receive one or more semiconductor devices (e.g., one or more semiconductor dice). A first set of contact pads is positioned at or proximate to the attach region so that discrete conductive elements (e.g., bond wires, conductive tape-automated bonding (TAB) elements carried upon a dielectric film, leads, or conductive structures such as balls, bumps, columns, pins, etc., formed from conductive material) may appropriately connect bond pads of the one or more semiconductor devices to corresponding contact pads of the first set. Each contact pad of the first set, or first contact pad, may be electrically connected to a corresponding contact pad of a second set, or second contact pad, by way of a conductive trace that extends therebetween.

In addition, an interposer according to the present invention may include a ground plane, a thermally conductive structure, which may form all or part of a thermal transfer element, or a combination thereof. If any of these structures

are present, they may be formed on the same surface of the interposer as that on which a die attach region is located and extend proximate to or at least partially into the die attach region. If these structures extend into the die attach region, they may comprise a part of the die attach region so as to be in contact with a semiconductor device upon placement thereof in that die attach region.

The interposer may also include “dummy” contact pads that do not communicate with a bond pad of the semiconductor device. Instead, the dummy contact pads may communicate with or comprise a part of a ground plane and/or a thermally conductive structure of the interposer. Dummy contact pads that communicate with or that are part of a thermally conductive structure of the interposer may be positioned so as to facilitate the transfer of heat away (i.e., the dissipation of heat) from a semiconductor device secured to the interposer or from an assembly or package that includes the interposer.

Each of the contact pads and conductive traces of the interposer may be carried upon the same, first surface thereof and in a single layer. Alternatively, the first and second sets of contact pads may be carried on opposite surfaces of the interposer substrate, with at least portions of the conductive traces, or electrically conductive vias positioned along the lengths thereof, being carried internally within the interposer substrate.

An interposer that incorporates teachings of the present invention also includes recesses that are configured to partially receive conductive structures, such as balls, bumps, columns, or pins. The recesses may be formed in a second surface of the interposer substrate, which is opposite from the first surface thereof or, if a semiconductor device is to be secured to the interposer in a flip-chip orientation, in the first surface of the interposer substrate. Each recess exposes and, thus, communicates with at least a portion of a surface of a corresponding second contact pad, dummy contact pad, or a portion of a ground plane and/or thermally conductive structure. The recesses may be arranged in a grid array or otherwise, as desired or required, to effect electrical connection to higher-level packaging.

A method for forming the interposer includes forming the first, second, and dummy contact pads, as well as the conductive traces, from one or more layers of conductive material on the interposer substrate. If one or both of a ground plane and a thermally conductive structure are desired, these structures may also be formed from the layer or layers of conductive material. By way of example only, each layer of conductive material may be laminated onto at least a portion of a surface of the interposer substrate or deposited thereon (e.g., by physical vapor deposition (PVD), such as sputtering, or by chemical vapor deposition (CVD)). Also by way of example and not to limit the scope of the present invention, the conductive features may be formed by known patterning processes. The recesses may be formed in the second surface of the interposer substrate at locations that correspond to the positions of each of the second contact pads and the dummy contact pads to which electrical connection is desired. Any suitable process may be used to form the recesses, including, without limitation, mask and etch processes that are appropriate for the material of the interposer substrate, laser ablation, die cutting or punching, drilling, milling, or other means known in the art. Formation of the recesses may be effected either before or after formation of the conductive features.

An assembly according to the present invention includes the interposer with at least one semiconductor device secured to a corresponding die attach region thereof. Each semiconductor device of such an assembly or package may be

5

attached to a corresponding die attach region of the interposer as known in the art, such as by use of an adhesive material, an adhesive-coated element (e.g., adhesive-coated tape), or otherwise. If the die attach region of the interposer includes a thermally conductive structure, a thermally conductive adhesive material may be used to secure the semiconductor device to the interposer and in thermal communication with the thermally conductive structure thereof. Bond pads of each semiconductor device may be electrically connected to corresponding first contact pads. Second contact pads that correspond to each first contact pad in communication with a bond pad of a semiconductor device have conductive structures, such as balls, bumps, columns, or pins formed from conductive material, secured thereto. Each of the conductive structures is partially contained within the recess that corresponds to the second contact pad to which that conductive structure is secured. In addition, if dummy contact pads are present on the interposer, one or more of the dummy contact pads may have conductive structures secured thereto. Conductive structures that correspond to dummy contact pads of the interposer may also be partially contained within corresponding recesses.

The use of a relatively thin interposer substrate that at least partially encompasses the conductive structures may reduce the overall height, or profile, of a semiconductor device assembly or package relative to an equivalent assembly or package with conductive structures that are not recessed relative to the interposer thereof.

Further, if the interposer of such a semiconductor device assembly or package includes a thermal transfer element or other thermally conductive structure in contact with the semiconductor device of the assembly or package, conductive structures that communicate with dummy contact pads or with the thermally conductive structure itself may provide enhanced thermal dissipation from the semiconductor device during operation thereof. In such an embodiment, the semiconductor device is oriented on the interposer in such a way that the thermal transfer element or other thermally conductive structure of the interposer and the semiconductor device are in contact with one another.

Assemblies according to the present invention that include more than one semiconductor device are referred to as multi-chip modules (MCMs). An MCM may be formed by stacking multiple assemblies of the present invention with adjacent assemblies electrically connected to one another by way of electrical connections between conductive structures protruding from an upper semiconductor device assembly and corresponding contact pads of a third set, or third contact pads, on an interposer of an underlying semiconductor device assembly. Each of the contact pads of the underlying assembly may communicate with either a first contact pad and, thus, a corresponding bond pad of a semiconductor device of that assembly or a second contact pad of the underlying assembly which, in turn, communicates with a conductive structure secured thereto.

Alternatively, the semiconductor devices of an MCM that incorporates teachings of the present invention may be stacked relative to one another or positioned at different locations on a single interposer and electrically connected to that interposer by discrete conductive elements positioned between bond pads of the semiconductor devices and corresponding first contact pads of the interposer.

A semiconductor device package according to the present invention includes an assembly with a suitable encapsulant or packaging material at least partially protecting one or both of a semiconductor device of the assembly and discrete conduc-

6

tive elements that electrically connect bond pads of the semiconductor device assembly and corresponding first contact pads of the interposer.

Other features and advantages of the present invention will become apparent to those of ordinary skill in the art through consideration of the ensuing description, the accompanying drawings, and the appended claims.

#### BRIEF DESCRIPTION OF THE SEVERAL VIEWS OF THE DRAWINGS

In the drawings, which illustrate exemplary embodiments for carrying out the invention:

FIG. 1A is top view of an interposer incorporating teachings of the present invention;

FIG. 1B is a top view of an interposer area depicted in FIG. 1A;

FIG. 1C is a cross-sectional representation of the interposer area depicted in FIG. 1B;

FIG. 2A is a cross-sectional representation of a semiconductor device package incorporating the teachings of the present invention;

FIG. 2B is a cross-sectional representation of a variation of the semiconductor device package illustrated in FIG. 2A;

FIG. 2C is a cross-sectional representation of the semiconductor device package illustrated in FIG. 2A with an increased thermal element area for heat dissipation;

FIG. 2D is a cross section of the semiconductor package illustrated in FIG. 2A with both an increased thermal element area and thermally conductive structures attached thereto;

FIG. 2E is a cross-sectional representation of the semiconductor device package illustrated in FIG. 2A with an increased area for thermally conductive structures and at least one heat transfer element attached thereto;

FIG. 3 is a cross-sectional representation of an exemplary embodiment of a multi-chip module incorporating teachings of the present invention, in which a series of separately packaged semiconductor devices are positioned in a stacked arrangement;

FIG. 4A is a cross-sectional representation of another exemplary embodiment of a multi-chip module incorporating teachings of the present invention, wherein semiconductor devices are stacked over and electrically connected to a single interposer;

FIGS. 4B, 4C, and 4D are cross-sectional representations of variations of the multi-chip module in FIG. 4A;

FIG. 5 is a cross-sectional representation of another exemplary embodiment of an interposer of the present invention, which includes a recess for at least partially receiving a semiconductor device, as well as a semiconductor device assembly including the interposer;

FIG. 6 is a cross-sectional representation of yet another exemplary embodiment of an interposer according to the present invention, which is configured to have at least one semiconductor device flip-chip bonded thereto, as well as an assembly including the interposer and a semiconductor device;

FIG. 7 is a cross-sectional representation of an interposer that incorporates teachings of the present invention and includes a semiconductor device flip-chip bonded to the same side thereof as that from which conductive structures protrude, as well as a semiconductor device assembly including the interposer; and

FIG. 8 is a side view of a multi-chip module including a plurality of semiconductor devices positioned at different lateral locations on the same interposer.

## DETAILED DESCRIPTION OF THE INVENTION

The present invention includes an interposer for use in semiconductor device assemblies and packages, assemblies and packages including the interposer, and multi-chip modules. The present invention also includes methods for designing and forming the interposer, as well as for forming semiconductor device assemblies and packages that include the interposer.

Referring to FIGS. 1A-1C, an interposer **20** of the present invention is illustrated. The interposer **20** includes a substrate **12**, which is also referred to herein as an “interposer substrate,” and at least one layer **52** of conductive structures. As depicted, the at least one layer **52** of conductive structures includes first contact pads **4** located proximate an attach location or region **7** on the substrate **12** and conductive traces **8** extending somewhat laterally from corresponding first contact pads **4** to corresponding second contact pads **2**. As shown in FIG. 1C, apertures **14** that are formed at least partially through the substrate **12** expose second contact pads **2** there-through.

The substrate **12** may be formed from either a rigid or flexible material and may comprise a substantially planar member. Silicon or another semiconductor material (e.g., gallium arsenide, indium phosphide, etc.) may be used to form the substrate **12** with at least some surfaces thereof, including those that will contact or be located proximate to the conductive structures of the interposer **20** or another semiconductor device component to be assembled therewith, being covered with an electrically insulative material (e.g., a silicon oxide or silicon nitride) to prevent electrical shorting of the conductive structures of the interposer **20**. Other suitable materials for forming the interposer substrate **12** include, without limitation, FR-4 resin, glass, ceramics, and polyimide.

The second contact pads **2** of the interposer **20** are arranged to provide a desired pattern, or “footprint”, of electrical connections to facilitate communication between at least one semiconductor device to be secured to the interposer **20** and external electronic devices through a larger-scale substrate, such as a circuit board or other carrier.

FIGS. 1B and 1C depict a second contact pad **2** of an interposer **20** incorporating teachings of the present invention. Conductive material, such as copper, aluminum, gold, or other conductive material, that is carried by the substrate **12** forms the second contact pads **2**, as well as the conductive traces **8** and the first contact pads **4**. When the second contact pads **2** are part of a layer **52** of conductive structures that is carried upon a surface of the substrate **12**, areas of the substrate **12** that are superimposed by the second contact pads **2** are substantially removed to form receptacles **11**, which facilitate the formation of electrical connections between the second contact pads **2** of the interposer **20** and other components, such as a circuit board or other carrier. The receptacles **11** are configured to at least partially receive conductive structures, such as balls, bumps, columns, pins, or other elements formed from conductive material such as a metal or metal alloy (e.g., solder) or a conductive or conductor-filled elastomer. Generally, it is preferable that the second contact pads **2** have a larger surface area than the adjacent end of the receptacle **11** corresponding thereto so that the substrate **12** will still provide adequate peripheral support for each second contact pad **2**.

Optionally, as shown in FIG. 1C, a protective layer **80** may be formed or positioned over conductive traces **8** and second contact pads **2**, opposite from substrate **12**. Protective layer **80** may provide additional physical support for second contact

pads **2**, as well as for conductive traces **8**. In addition, protective layer **80** electrically insulates conductive traces **8** and second contact pads **2**. Exemplary materials that may be used to form protective layer **80** include, but are not limited to, dielectric polymers, such as polyimide. By way of example only, a dielectric polymer may be coated over conductive traces **8** and second contact pads **2** by known processes (e.g., spin-on coating, use of a doctor blade, screen printing, sprayed on, etc.) or may comprise a preformed film (e.g., polyimide tape) that is adhered to substrate **12** over conductive traces **8** and second contact pads **2**.

The use of receptacles **11** in the interposer **20** of the present invention may shorten the physical lengths of circuits between the first contact pads **4** and their corresponding second contact pads **2**, which may reduce electrical inductance relative to that of a more conventional interposer by eliminating the need for conductive vias extending through the thickness of the substrate **12**.

Although FIG. 1C depicts a receptacle **11** as exposing a second contact pad **2**, the receptacles **11** may alternatively expose a portion of a conductive trace **8**, a first contact pad **4**, or another feature along a conductive path between a first contact pad **4** and its corresponding second contact pad **2**. As such, some receptacles **11** may facilitate testing of particular circuits once conductive structures have been secured to the second contact pads **2** of the interposer **20** and one or more semiconductor devices have been assembled therewith.

The receptacles **11** may be formed with draft angles, countersinks, chamfers, or radii or, alternatively, as recesses with substantially vertical sides. In addition, the cross-sectional shapes of the receptacles **11**, taken transverse to the depths thereof, may have circular, rectangular, or other desired shapes. Any process that is suitable for removing material of the type from which the interposer substrate **12** is formed may be used to form the receptacles **11**. For example, mask and etch processes may be used to form receptacles **11** in a substrate **12** that is formed from a semiconductor material, glass, or ceramic. Substrates **12** that are formed from resins, or polymers, may have receptacles **11** formed therein by mechanical processes, such as drilling (including laser drilling), punching, milling, or die cutting.

The interposer **20** of the present invention may include a thermally conductive element **6**, which may be formed from a thermally conductive material (i.e., a material conducive to heat transfer), such as copper, aluminum, gold, or the like. The thermally conductive element **6** may increase the overall thermal mass of the interposer **20** and, thus, act as a so-called “heat sink” for a semiconductor device positioned in thermal communication therewith. As depicted, the thermally conductive element **6** is located completely within the attach region **7**. Alternatively, a thermally conductive element **6** may be located only partially within the attach region **7** or lie completely outside of the attach region **7** and proximate thereto. Preferably, the thermally conductive element **6** is configured to thermally communicate with a semiconductor device disposed upon the interposer **20** so as to convey heat therefrom during operation of the semiconductor device. By way of example only, the thermally conductive element **6** may comprise a part of the at least one layer **52** of conductive structures and may be formed from the same material as one or more of the other conductive structures of that layer **52**. Preferably, the thermally conductive element **6** is electrically isolated from other electrically conductive structures of the interposer **20**.

The interposer **20** may also include a ground plane **5**. The thermally conductive element **6** and the ground plane **5** may comprise the same element or separate elements from one

another. Like the thermally conductive element 6, the ground plane 5 may be positioned completely within, partially within, or proximate to an attach region 7 of the interposer substrate 12.

Some of the receptacles 11 that are formed at least partially through the interposer substrate 12 may expose portions of a ground plane 5, a thermally conductive element 6, or a contact pad that communicates with the ground plane 5 and/or thermally conductive element 6. When receptacles 11 are used to facilitate the transfer of heat away from an assembly or package that includes the interposer, the location, volume, and shape of each such receptacle 11 may be tailored to provide particular heat dissipation characteristics. In addition or in the alternative, grooves (not shown) or other structures may be formed partially or completely through the interposer substrate 12 to expose portions of a thermally conductive element 6 and to facilitate the transfer of heat away from an assembly or package including the interposer 20. As an example, and not to limit the scope of the present invention, structures such as receptacles 11 and/or grooves (not shown) that facilitate the transfer of heat away from the thermally conductive element 6 may be distributed across the substrate 12 over roughly the same area as that occupied by thermally conductive element 6.

As another alternative, shown in FIGS. 2C-2E, an aperture 14' may be formed through the interposer substrate 12' to expose a large, central portion of the thermally conductive element 6 therethrough, with at least some peripheral regions of the thermally conductive element 6 being secured to and supported by the interposer substrate 12'.

Referring now to FIG. 2A, a package 21 including the above-described interposer 20 and a semiconductor device 36 (e.g., the illustrated semiconductor die) affixed thereto is depicted. The semiconductor device 36 may be secured to an attach region 7 of the interposer 20 by way of a die attach material 38, such as a suitable adhesive or adhesive-coated element. Bond pads 42 of the semiconductor device 36 may be electrically connected with corresponding first contact pads 4 of the interposer 20 by way of bond wires 32 or other intermediate conductive elements (e.g., leads, TAB elements carried by a dielectric film, etc.) that are secured to second contact pads 2 formed on the top surface 10 (FIG. 1A) thereof.

In addition, package 21 includes electrically conductive structures 34 secured to at least some of the second contact pads 2 of the substrate 12'. The electrically conductive structures 34 are positioned at least partially within the receptacles 11 formed in the interposer substrate 12' and, thus, are at least partially laterally surrounded by the interposer substrate 12'. Electrically conductive structures 34 may also be secured to a ground plane 5 of the interposer 20 or a contact (not shown in FIG. 2A) that communicates with the ground plane 5.

Thermally conductive structures 50, which resemble and may be formed from the same materials as those from which the electrically conductive structures 34 are formed, may be secured to a thermally conductive element 6 of the interposer 20 or to a contact (not shown in FIG. 2A) that communicates with the thermally conductive element 6. As with the thermally conductive element 6, the thermally conductive structures 50 may increase the overall thermal mass of a package 21 and, thus, act as a heat sink for the adjacent thermally conductive element 6, as well as for a semiconductor device 36 in communication with the thermally conductive element 6. In the event that a single structure forms both a ground plane 5 and a thermally conductive element 6, the conductive structures 34/50 protruding therefrom may be formed from a material that is both electrically and thermally conductive.

The electrically conductive structures 34 may, by way of example only, comprise balls, bumps, columns, pins, or other structures that are formed from an electrically conductive material, such as a metal, a metal alloy (e.g., solder), a conductive elastomer, or a conductor-filled elastomer. Also by way of example, the thermally conductive structures 50 may be formed from a metal, a metal alloy, or another thermally conductive material.

When the electrically conductive structures 34 or thermally conductive structures 50 comprise solder, another metal alloy, or a metal, these structures may be formed, as known in the art, by use of a solder mask 40 that has been secured to (in the case of a preformed film solder mask) or formed on (in the case of an applied solder mask material) the substrate 12' of interposer 20. Once the metal or solder structures have been formed, the solder mask 40 may remain in place adjacent to the interposer 20 or, optionally, be removed from the interposer 20.

When one or more semiconductor devices 36 have been secured and electrically connected to the interposer 20, each semiconductor device 36 may be partially or fully covered with an encapsulant material 30 of a known type, such as a suitable pot mold material, transfer mold material, glob top material, conformal coating material, or the like. Such encapsulant material 30 protects the covered regions of each semiconductor device 36, as well as the bond wires 32 or other intermediate conductive elements that electrically connect the bond pads 42 of the semiconductor device 36 and their corresponding first contact pads 4 on the interposer 20.

A package 21 of the present invention may have a total thickness of less than about 0.8 mm, making it suitable for use in compact electronic devices, such as cellular telephones, handheld computers, and portable computers, where such low-profile packages are required or desired.

FIG. 2B depicts a variation of package 21, in which the ends of the thermally conductive structures 50 that protrude from the interposer 20 are connected to one another by way of a heat transfer element 48. The heat transfer element 48, which further increases the overall thermal mass of the package 21 and, therefore, provides heat sink properties, effectively increases the surface area from which heat may dissipate and may, thereby, increase the rate at which the package 21 is able to dissipate heat by way of convection or radiation. As shown, the heat transfer element 48 is a substantially planar, unitary structure. Alternatively, the heat transfer element 48 may be formed from a number of separate sections. The heat transfer element 48 may optionally include holes, cut-outs, varying cross-sectional properties, or the like, or some combination thereof.

In addition, a surface 51 of the heat transfer element 48 may be mechanically, chemically, or otherwise configured to further enhance the ability of the heat transfer element 48 to dissipate heat from the semiconductor device 36. As examples of chemical treatments of the surface 51 of heat transfer element 48, processes such as coating, greening, or blackening may be employed to increase the emissivity of the heat transfer element 48 for radioactive heat transfer. Examples of mechanical configuration of the surface 51 of the heat transfer element 48 to enhance its heat dissipative properties include geometrical enhancements such as grooves, roughening, or other processes that increase the area of the surface 51. Such surface treatments may be effected before or after the heat transfer element 48 is attached to the thermally conductive structures 50. One or more regions of the surface of the heat transfer element 48 may also be coated with dielectric material to prevent electrical shorting.

11

FIGS. 2C-2E depict another embodiment of a package 21', which includes an interposer 20' with an interposer substrate 12' that includes an aperture 14' formed therethrough to expose a large portion of the central region of a thermally conductive element 6 that underlies a back side 37 of a semiconductor device 36. At least some of the peripheral edges of the thermally conductive element 6 overlap a surface of the interposer substrate 12' and are physically supported thereby. Also, the solder mask 40 of package 21', if any, does not extend over this portion of the thermally conductive element 6.

The exposed portion of the thermally conductive element 6 may remain exposed through the interposer substrate 12', as depicted in FIG. 2C. Any exposed regions of the surface of the thermally conductive element 6 may be chemically or mechanically treated in such a way as to enhance the thermally dissipative properties thereof, as well as to form an electrically insulative coating thereon. Alternatively, as shown in FIG. 2D, the package 21' may include thermally conductive structures 50 that are positioned within the aperture 14', secured to and protrude from exposed regions of the thermally conductive element 6, and are at least partially laterally surrounded by the interposer substrate 12'. FIG. 2E depicts another alternative, in which the package 21' includes a heat transfer element 48 secured to thermally conductive structures 50 that are secured to and protrude from the thermally conductive element 6.

Turning now to FIG. 5, another exemplary embodiment of interposer 20" according to the present invention is depicted. Interposer 20" includes a receptacle 22 that is configured to at least partially receive a semiconductor device 36 to be electrically connected thereto. The remaining features of interposer 20" are substantially the same as those of interposer 20 shown in FIGS. 1A-1C.

FIG. 6 depicts another embodiment of an interposer 120, of which the first contact pads 4 are positioned in an attach region 7 and positioned to mirror the locations of bond pads 42 so as to facilitate flip-chip attachment of a semiconductor device 36 thereto. The remaining features of interposer 120 are substantially the same as those of interposer 20 shown in FIGS. 1A-1C.

Referring to FIG. 7, another embodiment of interposer 120" is depicted. Interposer 120" includes a receptacle 22" formed in the same surface as that to which receptacles 11 open. Receptacle 22" is configured to at least partially receive a semiconductor device 36 in a flip-chip orientation. Accordingly, first contact pads 4" are positioned within the receptacle 22". Conductive traces 8" that communicate with the first contact pads 4" extend across the interposer substrate 12", either on a surface thereof, as shown, or internally therethrough. The conductive traces 8" extend laterally to the locations of corresponding second contact pads 2", which are exposed through the receptacles 11 that are formed through the interposer substrate 12" so as to at least partially expose corresponding second contact pads 2".

Turning now to FIG. 3, an exemplary embodiment of a multi-chip module 60 according to the present invention is depicted. As shown, the multi-chip module 60 includes two packages 121: an upper package 121U and a lower package 121L.

At least the lower package 121L of such a multi-chip module 60 includes an aperture 9 formed through the top of the encapsulant material 30 thereof. Each aperture 9 is configured to at least partially receive a corresponding conductive structure 34 that protrudes from the bottom of an overlying upper package 121U. A contact pad of a third set, which

12

contact pad is referred to herein as a third contact pad 16, is exposed within each aperture 9.

Some third contact pads 16 of the package 121 may communicate with corresponding first contact pads 4 and, thus, ultimately, with the bond pads 42 and corresponding internal circuitry a semiconductor device 36 of the package 121 by way of a conductive trace 8 positioned between the third contact pad 16 and the corresponding first contact pad 4. Some third contact pads 16 of the package 121 may communicate with corresponding second contact pads 2 and, thus, ultimately with one or more electronic components that are external to the package 121 by way of a via 15 or other conductive element positioned between the third contact pad 16 and the corresponding second contact pad 2. Thus, a conductive structure 34 that protrudes from an upper package 121U and its corresponding third contact pad 16 of the next-lower package 121L may facilitate communication between a semiconductor device 36 of the upper package 121U and either a semiconductor device 36 of the next-lower package 121L or an external electronic device.

Based on an overall package height of about 0.8 mm (assuming the height that the encapsulant material 30 protrudes above the interposer 20 is about 0.5 mm, that the receptacles 11 extend completely through the interposer 20, and that the electrically conductive structures 34 therein have heights of about 0.3 mm), the overall thickness of the multi-chip module 60 depicted in FIG. 3 may be about 1.5 mm since the apertures 9 at least partially receive the heights of the electrically conductive structures 34 that protrude from the upper package 121U.

While FIG. 3 depicts a multi-chip module 60 that includes two vertically stacked packages 121U and 121L, it will be understood that a multi-chip module incorporating teachings of the present invention may include more than two packages.

Another exemplary embodiment of multi-chip module incorporating teachings of the present invention may be formed by securing multiple semiconductor devices to a single interposer. The semiconductor devices may be positioned at different locations on the interposer, as shown in FIG. 8, or stacked over one or more locations of the interposer, as shown in FIGS. 4A-4D.

With reference to FIG. 4A, a multi-chip module 70 that includes a single interposer 20 with semiconductor devices 36, 36' stacked over the same attach region 7 thereof is depicted. The lower semiconductor device 36 is secured to the interposer 20 by way of a die attach material 38, while another quantity of die attach material 39, such as a suitable adhesive or adhesive-coated element, secures the upper semiconductor device 36' to the lower semiconductor device 36. Intermediate conductive elements, such as the depicted bond wires 32, 32', electrically connect respective bond pads 42, 42' of the semiconductor devices 36, 36' to corresponding first contact pads 4, 4' of the interposer 20.

The multi-chip module 70 may also include electrically conductive structures 34 and/or thermally conductive structures 50 that communicate with second contact pads 2 (FIGS. 1A-1C) and a thermally conductive element 6, respectively.

Such a multi-chip module 70 assembly may be packaged, as known in the art, such as by applying a suitable encapsulant material 30 (e.g., a glob-top type encapsulant, a transfer molded or pot molded type encapsulant, etc.) over at least portions of semiconductor devices 36, 36', the intermediate conductive elements (e.g., bond wires 32, 32'), and at least portions of the interposer 20.

In FIG. 4B, a multi-chip module 70' that includes a plurality of semiconductor devices 36, 36' and an interposer 20' of the type depicted in FIGS. 2A-2C is illustrated. In the

13

depicted example, the thermally conductive structures 50 of the multi-chip module 70' are positioned within the aperture 14' formed through the substrate 12' of the interposer 20' and are secured directly to the thermally conductive element 6. In addition, the multi-chip module 70' may include a heat transfer element 48 secured to at least some of the thermally conductive structures 50. FIG. 4C illustrates an embodiment of multi-chip module 70' in which the thermally conductive element 6 is exposed through the aperture 14' formed through the interposer substrate 12'.

Also, as shown in FIGS. 4C and 4D, a second thermally conductive element 6' may be positioned over an active surface 35' of the upper semiconductor device 36' to facilitate the dissipation of heat therefrom. Of course, in order to provide the desired heat transfer characteristics, at least a portion of the second thermally conductive element 6' may be exposed through an encapsulant material 30 that covers portions of the upper semiconductor device 36'. As with thermally conductive element 6, one or more surfaces of the second thermally conductive element 6' may be chemically or mechanically treated so as to improve the heat dissipation characteristics thereof.

As depicted in FIG. 8, an interposer 20''' with more than one attach region 7 thereon may be used to form a multi-chip module 70''' with semiconductor devices 36 at different lateral positions. Of course, each semiconductor device 36 may be secured and electrically connected to such an interposer 20''' as described above with reference to FIG. 2A.

Although the foregoing description contains many specifics, these should not be construed as limiting the scope of the present invention, but merely as providing illustrations of some exemplary embodiments. Similarly, other embodiments of the invention may be devised which do not depart from the spirit or scope of the present invention. Features from different embodiments may be employed in combination. The scope of the invention is, therefore, indicated and limited only by the appended claims and their legal equivalents, rather than by the foregoing description. All additions, deletions, and modifications to the invention, as disclosed herein, which fall within the meaning and scope of the claims are to be embraced thereby.

What is claimed is:

1. An interposer for use in a semiconductor device assembly or package, comprising:

an interposer substrate;

at least one conductive structure comprising at least one of a thermally conductive element and a ground plane carried by a surface of the interposer substrate and configured to communicate with a back side of a semiconductor die;

a plurality of contact pads laterally offset from the at least one conductive structure and electrically isolated therefrom; and

at least one recess in a surface of the interposer substrate opposite the surface carrying the at least one conductive structure, the at least one recess exposing the at least one conductive structure.

2. The interposer of claim 1, further comprising:

another plurality of contact pads, each contact pad of the another plurality being laterally offset from a contact pad of the plurality of contact pads.

3. The interposer of claim 2, further comprising:

a plurality of conductive traces extending between at least some contact pads of the plurality and corresponding contact pads of the another plurality.

14

4. The interposer of claim 3, wherein at least a portion of at least one of the plurality of conductive traces is carried within the interposer substrate.

5. The interposer of claim 3, wherein each of the plurality of contact pads, the plurality of conductive traces, and the another plurality of contact pads is at least partially carried upon a same, substantially planar surface of the interposer substrate.

6. The interposer of claim 5, wherein at least one attach region is located on the same substantially planar surface of the interposer substrate as the plurality of contact pads, the plurality of conductive traces, and the another plurality of contact pads are carried upon.

7. The interposer of claim 2, further comprising:

a plurality of recesses formed in a surface of the interposer, at least partially through the interposer substrate and in alignment with at least some contact pads of the plurality of contact pads or the another plurality of contact pads.

8. The interposer of claim 7, wherein at least one attach region is located on a surface of the interposer substrate opposite the surface in which the plurality of recesses is formed.

9. The interposer of claim 7, wherein at least one attach region is located upon the same surface of the interposer substrate as that in which the plurality of recesses is formed.

10. The interposer of claim 2, further comprising:

at least one upper contact pad accessible from a surface of the substantially planar interposer substrate opposite from that at which the plurality of contact pads or the another plurality of contact pads are accessible.

11. The interposer of claim 1, further comprising:

a plurality of recesses formed in the opposite surface of the interposer substrate to expose at least portions of the plurality of contact pads.

12. A semiconductor device assembly, comprising:

an interposer including:

a substantially planar surface carrying contact pads and at least one conductive structure comprising at least one of a thermally conductive element and a ground plane; and

a surface opposite the substantially planar surface and including at least one recess therein exposing the at least one conductive structure; and

at least one semiconductor device including:

a back side in communication with the at least one conductive structure; and

bond pads that communicate with corresponding contact pads of the interposer.

13. The semiconductor device assembly of claim 12, further comprising:

at least one discrete conductive element secured to the at least one conductive structure.

14. The semiconductor device assembly of claim 13, wherein the at least one discrete conductive element is at least partially laterally surrounded by the interposer.

15. The semiconductor device assembly of claim 12, wherein contact surfaces of the contact pads are recessed relative to a surface of the interposer.

16. The semiconductor device assembly of claim 15, wherein the at least one semiconductor device is secured to the same surface as that in which the contact surfaces are recessed.

15

17. The semiconductor device assembly of claim 16, wherein the at least one semiconductor device is secured and electrically connected to the interposer in a flip-chip orientation.

18. The semiconductor device assembly of claim 15, wherein the at least one semiconductor device is secured to an opposite surface from that in which the contact surfaces are recessed.

19. The semiconductor device assembly of claim 18, wherein the interposer comprises a recess configured to at least partially receive the at least one semiconductor device.

20. The semiconductor device assembly of claim 15, wherein the contact pads are carried upon an opposite surface of the interposer than that in which contact receptacles in which the contact pads are recessed are formed.

21. The semiconductor device assembly of claim 12, wherein the interposer comprises a recess configured to at least partially receive the at least one semiconductor device.

22. The semiconductor device assembly of claim 12, wherein the at least one conductive structure is in contact with at least a portion of the back side of the at least one semiconductor device.

23. The semiconductor device assembly of claim 15, wherein the at least one recess is formed in the same surface of the interposer as that in which the contact pads are recessed.

24. A method for fabricating an interposer, comprising: providing a substantially planar interposer substrate with a conductive layer on a surface thereof;

patterning the conductive layer to form contact pads and at least one conductive structure for communicating with a back side of a semiconductor device; and forming at least one recess including tapered side walls in an opposite surface of the substantially planar interposer to expose the at least one conductive structure.

25. The method of claim 24, wherein patterning the conductive layer comprises patterning the conductive layer to form conductive traces extending laterally from the contact pads and outer contact pads at an opposite end of the conductive traces from the contact pads.

26. The method of claim 25, further comprising: forming a plurality of recesses in the opposite surface of the substantially planar interposer substrate to expose at least portions of the contact pads.

27. The method of claim 24, further comprising: forming a plurality of recesses in the opposite surface of the substantially planar interposer substrate to expose at least portions of the contact pads.

28. The method of claim 24, further comprising: forming the conductive layer on the surface of the substantially planar interposer substrate.

29. The method of claim 24, further comprising: forming at least one recess for at least partially receiving at least one semiconductor device in a surface of the substantially planar interposer substrate.

30. The method of claim 29, wherein forming the at least one recess is effected in the same surface as that upon which the conductive layer is located.

31. The method of claim 29, wherein forming the at least one recess is effected in a different surface than that upon which the conductive layer is located.

32. A method for designing an interposer, comprising: configuring a substantially planar interposer substrate; configuring at least one attach location on a surface of the substantially planar interposer substrate; configuring contact pads on the surface of the substantially planar interposer substrate;

16

configuring at least one conductive structure comprising at least one of a thermally conductive element and a ground plane to be carried at least partially by the at least one attach location for communicating with a back side of a semiconductor die secured to the at least one die attach location; and

configuring at least one recess in an opposite surface of the substantially planar interposer substrate to expose the at least one conductive structure at the opposite surface.

33. The method of claim 32, further comprising: configuring conductive trace locations to be carried by the substantially planar interposer substrate; and

configuring outer contact pad locations to be carried by the substantially planar interposer substrate, each outer contact pad location being configured to be offset from a corresponding contact pad location, each conductive trace location being configured to extend between a contact pad location and a corresponding outer contact pad location.

34. The method of claim 32, further comprising: configuring a plurality of recesses to be formed in the opposite surface of the substantially planar interposer substrate to at least partially expose corresponding contact pads.

35. The method of claim 34, wherein configuring the at least one attach location comprises configuring the at least one attach location on the same surface of the substantially planar substrate as that in which the plurality of recesses is configured.

36. The method of claim 34, wherein configuring the at least one attach location comprises configuring the at least one attach location in an opposite surface of the substantially planar substrate from that in which the plurality of recesses is configured.

37. The method of claim 32, further comprising: configuring a plurality of recesses to be formed in the substantially planar interposer substrate to expose the contact pads.

38. The method of claim 32, wherein configuring the at least one conductive structure comprises configuring at least one thermally conductive element location at least partially within the at least one attach location.

39. The method of claim 38, further comprising: configuring a plurality of recesses in the opposite surface to expose the contact pads.

40. The method of claim 32, wherein configuring the at least one conductive structure comprises configuring at least one ground plane at least partially within the at least one attach location.

41. A method for forming a semiconductor device assembly, comprising:

securing at least one semiconductor device to a conductive structure comprising at least one of a thermally conductive element and a ground plane at an attach location of a substantially planar interposer with a back side of the at least one semiconductor device communicating with the conductive structure, the conductive structure exposed through at least one recess in a surface of the substantially planar interposer opposite a side of the conductive structure to which the at least one semiconductor device is secured; and

electrically connecting the at least one semiconductor device with the interposer.

42. The method of claim 41, wherein providing the interposer comprises providing an interposer with recessed contact pads.

17

43. The method of claim 42, further comprising:  
securing at least one discrete conductive element to the  
conductive structure, the at least one discrete conductive  
element being at least partially laterally surrounded by  
the interposer.  
44. The method of claim 42, wherein electrically connect-  
ing the at least one semiconductor device comprises securing  
the at least one semiconductor device to the same surface of  
the interposer as that in which the contact pads are recessed.

18

45. The method of claim 42, wherein electrically connect-  
ing the at least one semiconductor device comprises securing  
the at least one semiconductor device to an opposite surface  
of the interposer as that in which the contact pads are  
recessed.  
46. The method of claim 41, further comprising:  
at least partially encapsulating at least the at least one  
semiconductor device.

\* \* \* \* \*