



US 20080067695A1

(19) **United States**

(12) **Patent Application Publication**  
**Chow et al.**

(10) **Pub. No.: US 2008/0067695 A1**

(43) **Pub. Date: Mar. 20, 2008**

(54) **SEMICONDUCTOR ASSEMBLY WITH COMPONENT ATTACHED ON DIE BACK SIDE**

**Publication Classification**

(51) **Int. Cl.**  
*H01L 23/52* (2006.01)  
*H01L 21/00* (2006.01)  
(52) **U.S. Cl.** ..... 257/777; 438/108; 257/E23.085  
(57) **ABSTRACT**

(75) **Inventors:** **Seng Guan Chow**, Singapore (SG); **Francis Heap Hoe Kuan**, Singapore (SG)

**Correspondence Address:**  
**KLARQUIST SPARKMAN, LLP**  
**121 SW SALMON STREET, SUITE 1600**  
**PORTLAND, OR 97204**

One or more electronic components can be mounted on the back side of a semiconductor die. The components can be passive components, active components, or combinations thereof. The components can be soldered to signal routes on the back side of the die, the signal routes being attached to the die using a metallization layer or using one or more dielectric layer sections. Placing components on the back side of the die can allow for incorporation of the components without necessarily increasing the form factor of the die's package.

(73) **Assignee:** **STATS ChipPAC, Inc.**

(21) **Appl. No.:** **11/521,974**

(22) **Filed:** **Sep. 14, 2006**

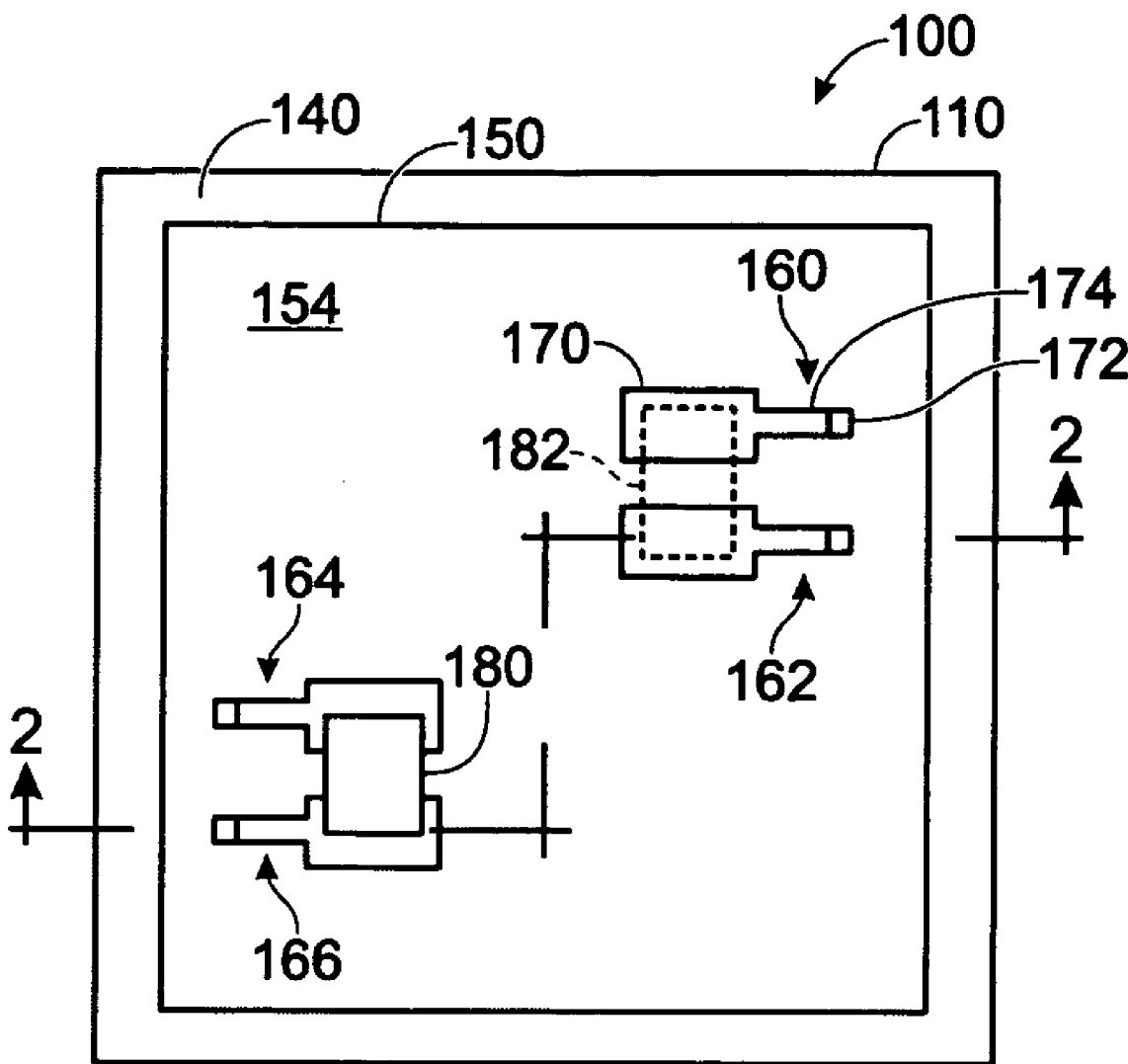

FIG. 1

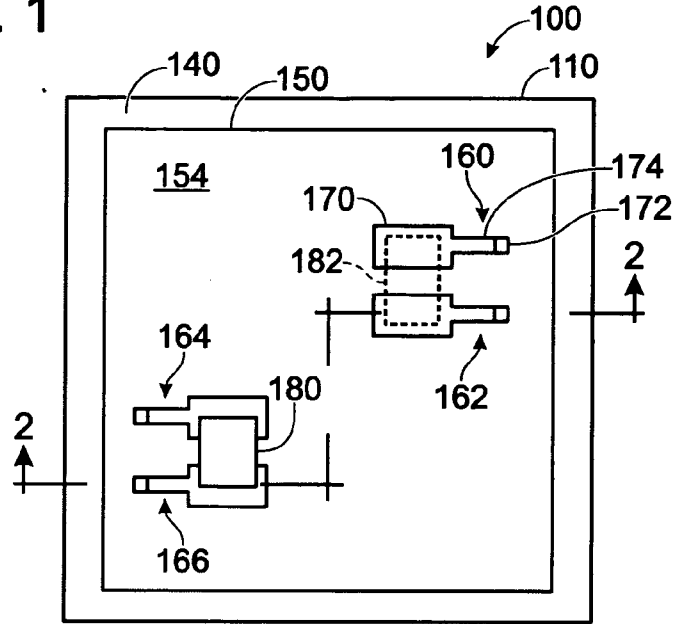

FIG. 2

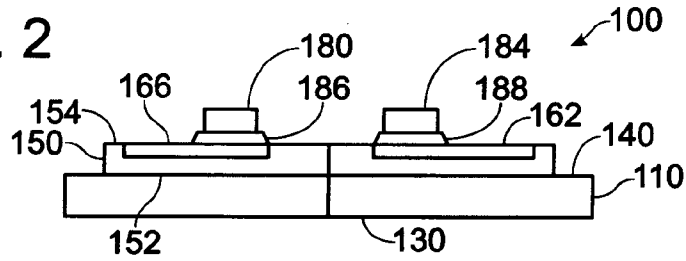

FIG. 3

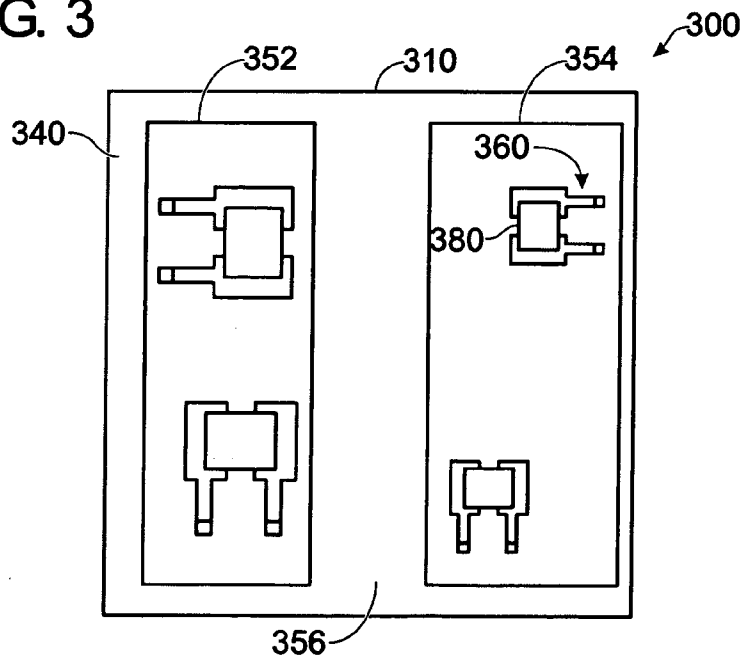

FIG. 4

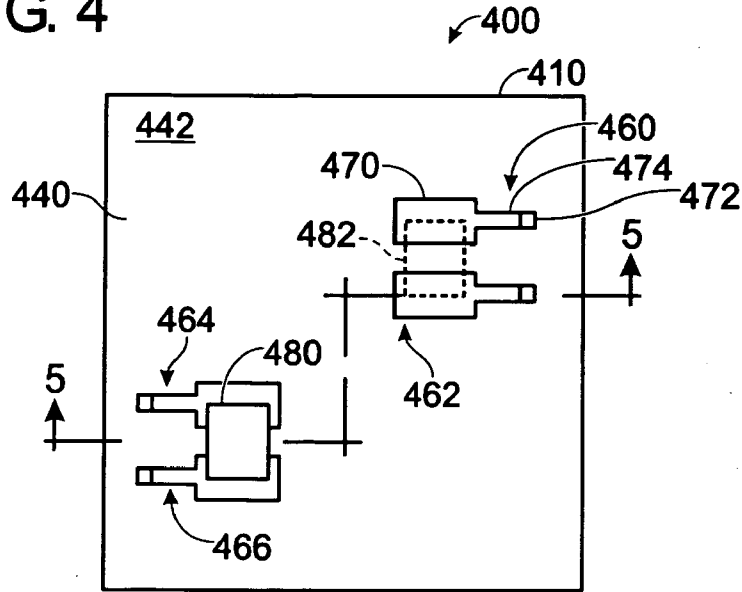

FIG. 5

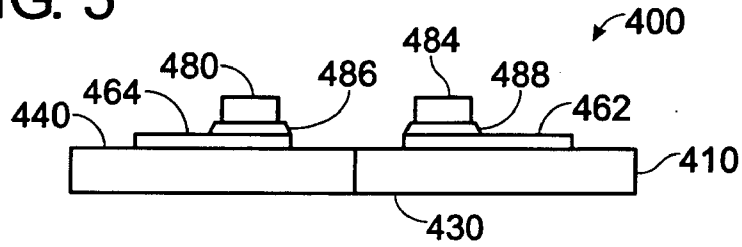

FIG. 6

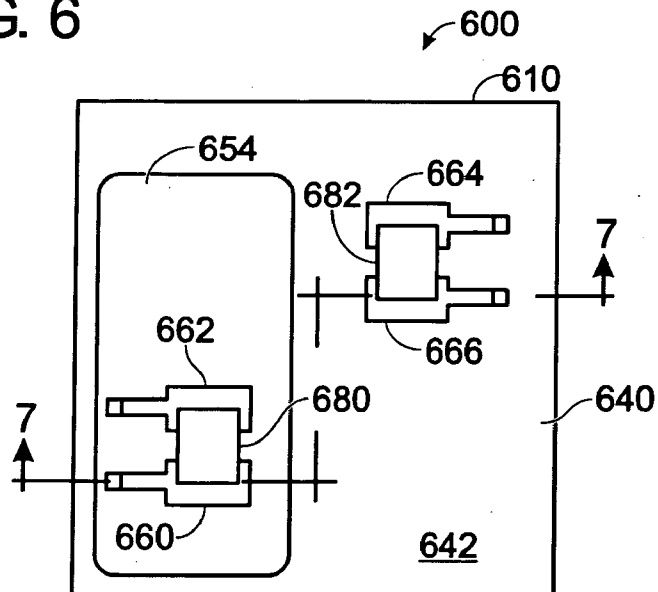

FIG. 7

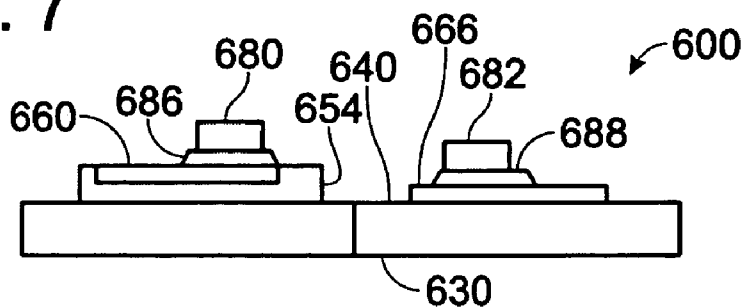

FIG. 8

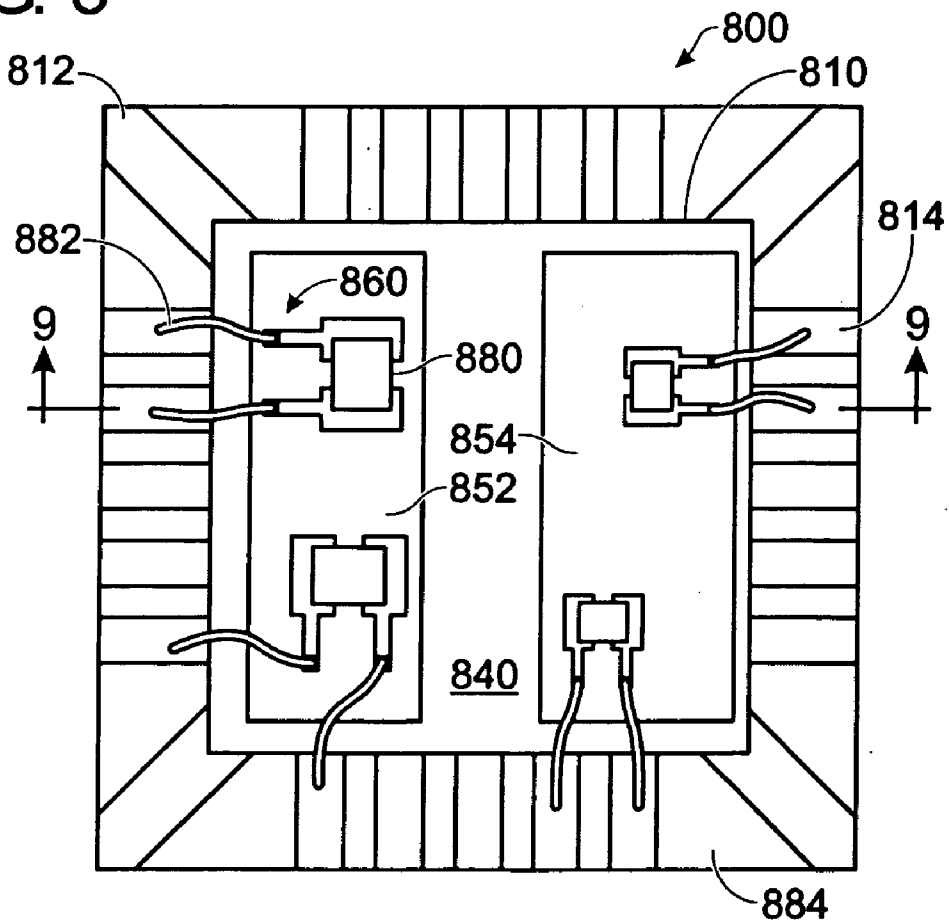

FIG. 9

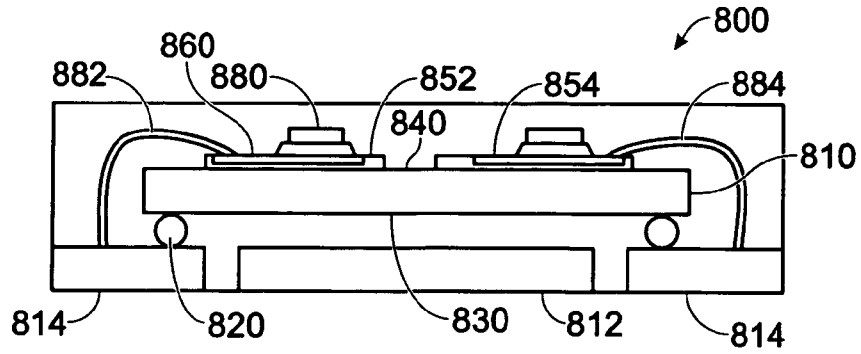

FIG. 10

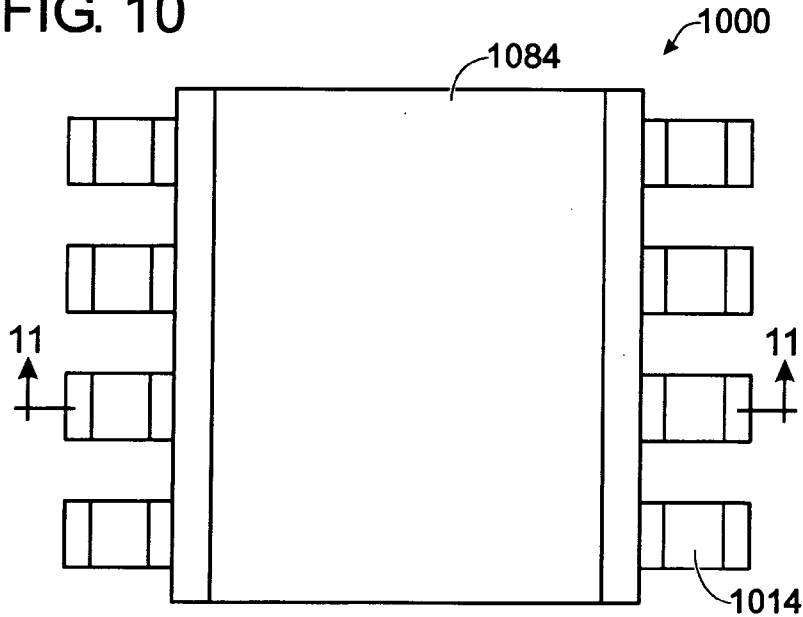
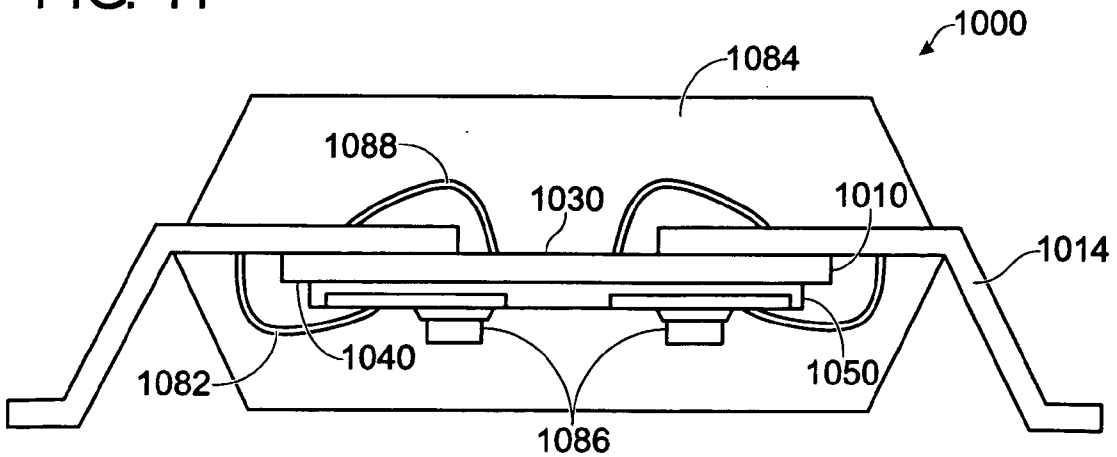

FIG. 11



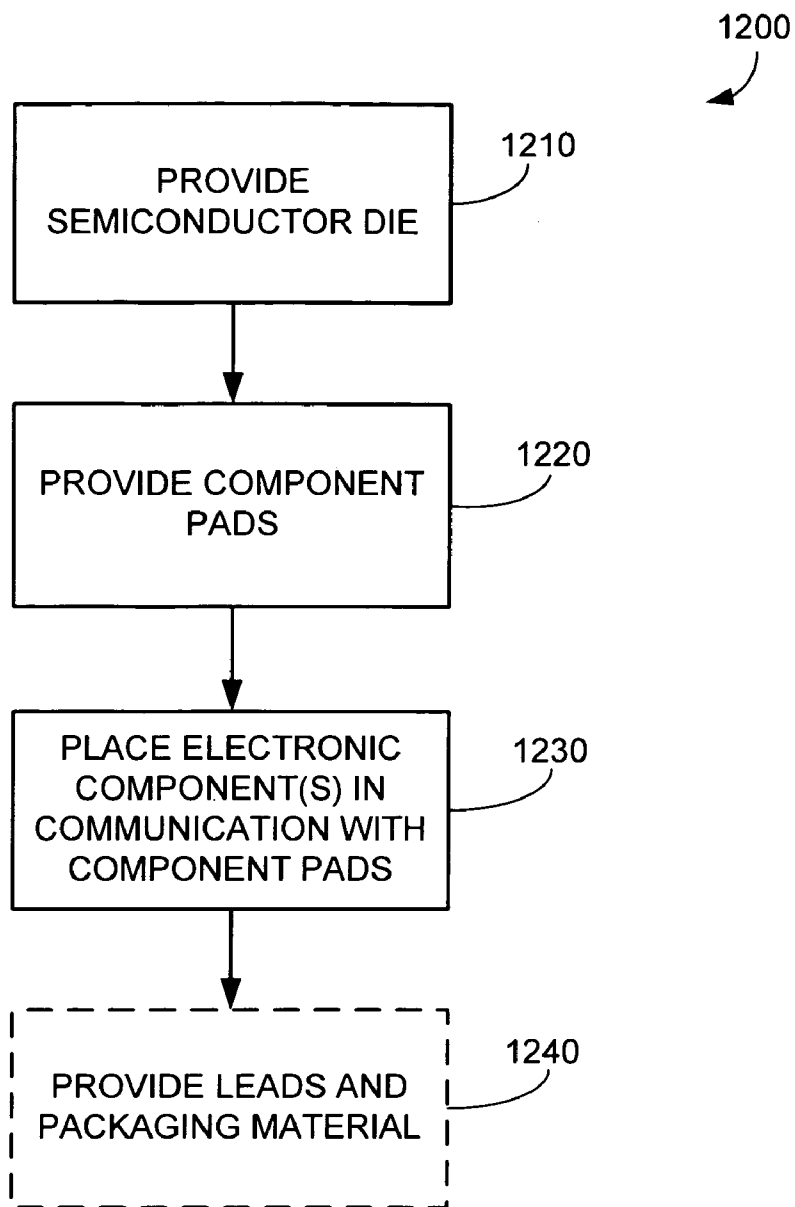

FIG. 12

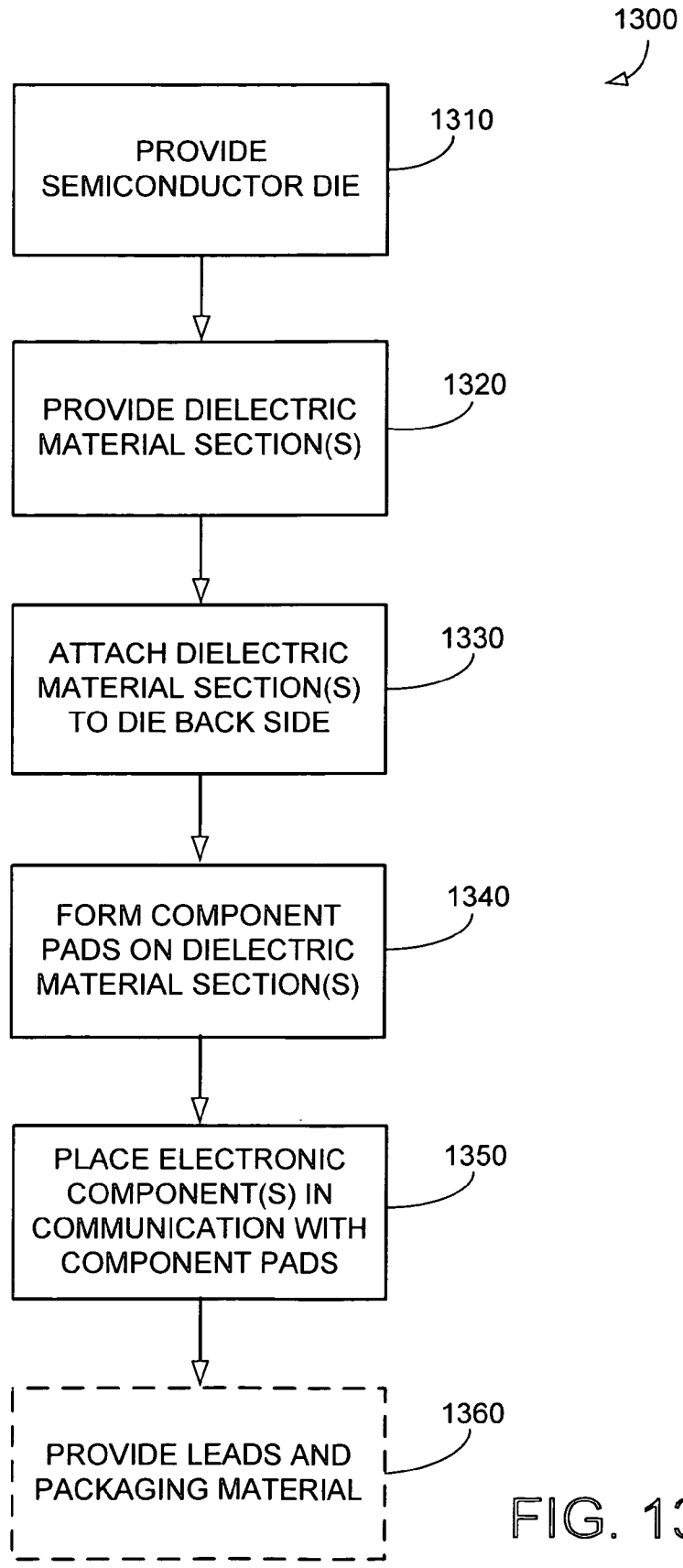

FIG. 13

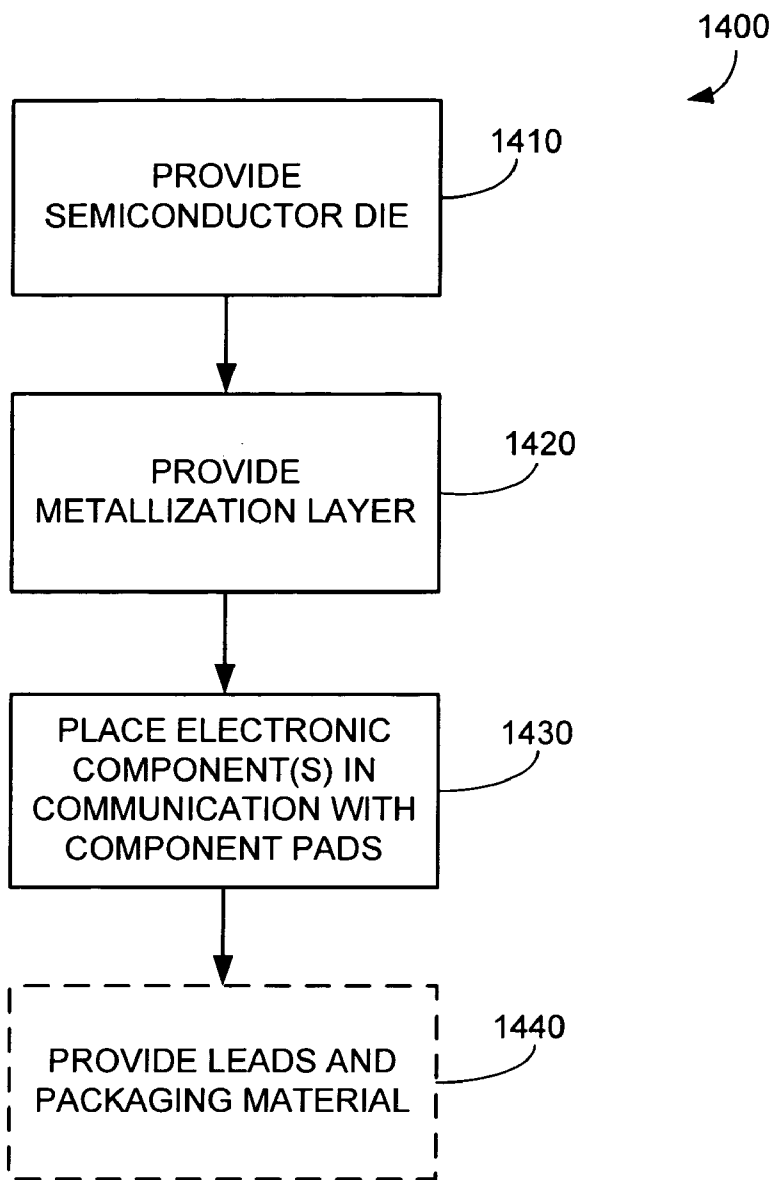

FIG. 14

**SEMICONDUCTOR ASSEMBLY WITH  
COMPONENT ATTACHED ON DIE BACK  
SIDE**

FIELD

**[0001]** The disclosure relates to semiconductor packaging.

BACKGROUND

**[0002]** Microchips are often packaged in various containers. It can be desirable to package a microchip with additional components, such as discrete components or other microchips. For example, U.S. Pat. No. 7,005,325 to Chow et al. states: “[P]assive components have been placed on the leadframe [of a semiconductor package] between the leads to eliminate negative electrical effects. These passive devices include capacitors, resistors, and inductors.” See col. 1, lines 33-36. However, including these additional components in a package (e.g., along the periphery of the die) can increase the package form factor.

**[0003]** One approach to accommodating two or more microchips inside a single package is described in U.S. Pat. No. 6,768,190 to Yang et al., which discloses “a multi-chip module having a stack type flip-chip design for accommodating two or more chips each having a different function inside a single package, thereby reducing overall production cost.” See col. 2, lines 7-10.

SUMMARY

**[0004]** A semiconductor assembly can be made up, at least in part, of a semiconductor die having an active side and a back side, with one or more electronic components mounted on the back side of the die. The components can be passive components, active components, or combinations thereof. The components can be attached to the die using a metallization layer or one or more dielectric material sections. Placing components on the back side of the die can allow for incorporation of the components without necessarily increasing the form factor of the die’s package.

**[0005]** In one embodiment, a semiconductor assembly comprises a semiconductor die having an active side and a back side, a dielectric material having a first side and a second side, with the first side of the dielectric material attached to the back side of the semiconductor die, a plurality of component pads attached to the second side of the dielectric material section, and one or more electronic components electrically coupled to one or more of the component pads. One or more of the electronic components can be a passive component. A plurality of signal traces can be electrically coupled with the plurality of component pads. A plurality of bond pads can be electrically coupled with the plurality of component pads. In some embodiments, the dielectric material section comprises a first section of dielectric material and a second section of dielectric material. In other embodiments at least one of the one or more electronic components has exactly two terminals. At least one of the electronic components can be in communication with a component pad via a solder connection, wherein the dielectric material provides a solder non-wettable area for the solder connection. In some embodiments the dielectric material section exposes a substantial portion of the back side of the semiconductor die. In other embodiments, the assembly further comprises a metallization layer having a first side and a second side, the first side being attached to

the die back side, the metallization layer comprising a plurality of component pads. In yet other embodiments, the assembly is packaged in a flip chip package. The package can further comprise a die paddle and a packaging material, the packaging material at least partially encompassing the semiconductor die.

**[0006]** In a further embodiment, a semiconductor assembly comprises a semiconductor die having an active side and a back side, a metallization layer having a first side and a second side, the first side attached to the die back side and the metallization layer comprising a plurality of component pads, and one or more discrete electronic components electrically coupled with at least two of the plurality of component pads. In some embodiments, the one or more discrete electrical components are passive components. In an additional embodiment, the second side of the metallization layer is not in contact with a passivation layer. The assembly can further comprise a plurality of signal traces can be in electrical communication with the plurality of component pads. The assembly can further comprise a plurality of wirebond pads can be in electrical communication with the plurality of component pads. The metallization layer can be a selective metallization coating with a mask or a selectively etched metallization coating. In one embodiment, at least one of the electronic components is attached to the component pads via a plurality of solder connects, wherein the die back side provides a solder non-wettable area for at least one of the solder connects.

**[0007]** In yet another embodiment, a method of packaging an integrated circuit comprises providing a semiconductor die having an active side and a back side, providing a dielectric material section having an active side and a back side, attaching the first side of the dielectric material section to the back side of the semiconductor die, forming a plurality of component pads on the second side of the dielectric material section, and electrically coupling one or more electronic components with at least two of the plurality of component pads. In some embodiments, at least one of the electronic components can be a passive component. The dielectric material layer can comprise a first section of dielectric material and a second section of dielectric material. Electrically coupling one or more electronic components with at least two of a plurality of component pads can comprise creating one or more solder connections between the electronic components and the component pads, wherein the dielectric material provides a solder non-wettable area for the solder connection. In further embodiments, at least part of the semiconductor die can be encapsulated with one or more packaging materials.

**[0008]** In another embodiment a method of making a semiconductor assembly comprises providing a semiconductor die having an active side and a back side, providing a metallization layer having a first side and a second side, the first side being attached to the die back side, wherein the metallization layer comprises a plurality of component pads, and further comprising electrically coupling one or more discrete electronic components with at least two of the plurality of component pads. In a further embodiment, at least one of the discrete electronic components is a passive component. In yet another embodiment, the second side of the metallization layer is not in contact with a passivation layer.

**[0009]** The foregoing and other objects, features, and advantages of the invention will become more apparent from

the following detailed description, which proceeds with reference to the accompanying figures.

#### BRIEF DESCRIPTION OF THE DRAWINGS

**[0010]** FIG. 1 is a plan view of one embodiment of a semiconductor assembly with a component attached to the back side of a die.

**[0011]** FIG. 2 is a cross-sectional view of the embodiment shown in FIG. 1.

**[0012]** FIG. 3 is a plan view of one embodiment of a semiconductor assembly with a component attached to the back side of a die.

**[0013]** FIG. 4 is a plan view of one embodiment of a semiconductor assembly with a component attached to the back side of a die.

**[0014]** FIG. 5 is a cross-sectional view of the semiconductor assembly of FIG. 4.

**[0015]** FIG. 6 is a plan view of one embodiment of a semiconductor assembly with components attached to the back side of a die.

**[0016]** FIG. 7 is a cross-sectional view of the semiconductor assembly of FIG. 6.

**[0017]** FIG. 8 is a plan view of one embodiment of a die in a flip chip package.

**[0018]** FIG. 9 is a cross-sectional view of the flip chip package of FIG. 8.

**[0019]** FIG. 10 is a plan view of one embodiment of a bond-on-lead package.

**[0020]** FIG. 11 is a cross-sectional view of the package of FIG. 10.

**[0021]** FIG. 12 is a flowchart for one embodiment of a method for making a semiconductor assembly.

**[0022]** FIG. 13 is a flowchart for one embodiment of a method for making a semiconductor assembly.

**[0023]** FIG. 14 is a flowchart for one embodiment of a method for making a semiconductor assembly.

#### DETAILED DESCRIPTION

**[0024]** As used in this application and in the claims, the singular forms “a,” “an,” and “the” include the plural forms unless the context clearly dictates otherwise. Additionally, the term “includes” means “comprises.” Further, the term “coupled” means electrically or electromagnetically coupled or linked and does not exclude the presence of intermediate elements between the coupled items.

**[0025]** The system, apparatus, and method described herein are provided to exemplify the invention, and the scope of the invention, and the scope of the invention is not limited to such exemplary features. Instead, the present disclosure is directed toward all novel and non-obvious features and aspects of the various disclosed embodiments, alone and in various combinations and sub-combinations with one another. The disclosed embodiments are not limited to any specific aspect or feature or combinations thereof.

**[0026]** Although the operations of embodiments of the disclosed method are described in a particular, sequential order for convenient presentation, it should be understood that this manner of description encompasses rearrangement, unless a particular ordering is required by specific language set forth below. For example, operations described sequentially may in some cases be rearranged or performed concurrently. Moreover, for the sake of simplicity, the attached figures may not show the various ways in which the dis-

closed system, method, and apparatus can be used in conjunction with other systems, methods, and apparatus. Additionally, the description sometimes uses terms like “produce” and “provide” to describe the disclosed method. These terms are high-level abstractions of the actual operations that can be performed. The actual operations that correspond to these terms can vary depending on the particular implementation and are readily discernible by one of ordinary skill in the art.

**[0027]** FIG. 1 shows a plan view of one embodiment of a semiconductor assembly 100 comprising an integrated circuit die 110. The die 110 comprises an active side 130 (shown in FIG. 2) having circuit elements (not shown) and a back side 140, the back side 140 being substantially opposite to the active side 130. A section of dielectric material 150 (e.g., circuitry tape or a similar material) can comprise a first surface 152 (shown in FIG. 2) and a second surface 154. The first surface 152 of the dielectric material section 150 can be attached to the back side 140 by any suitable method. For example, in one embodiment the dielectric material section 150 can be attached by lamination, and in another embodiment, it can be attached by adhesive. Second surface 154 of the dielectric material section 150 includes one or more signal routes such as signal routes 160, 162, 164, 166. As used in this application and in the claims, “signal route” refers to a section of conductive material for conveying electric signals. The signal route 160 can comprise a component pad 170, a signal trace 174 and a bond pad 172. As used in this application and in the claims, “component pad” refers to a region of conductive material for mounting an electronic component, “signal trace” refers to a region of conductive material designed to carry an electric signal, and “bond pad” refers to a region of conductive material for forming a connection with a wire. In some embodiments, the bond pad 172 is position adjacent to edge of die 110 to facilitate wire bonding. The signal route 160 can comprise the component pad 170, the signal trace 174 and the bond pad 172 as separate components, or the signal route 160 can be a continuous piece of conductive material. The signal routes 162, 164, 166 can comprise components similar to the signal route 160, although the signal routes 160, 162, 164, 166 can vary with respect to size and shape. An electronic component 180 can be electrically coupled to one or more of the signal routes 160, 162, 164, 166 at, for example, the component pad, using one or more methods known in the art, such as surface-mount technology (SMT). For example, FIG. 2 illustrates two electronic components 180, 184 electrically coupled to the signal routes 166, 162, respectively, via the solder connections 186, 188, respectively. Returning to FIG. 1, region 182 exemplifies one position where an electronic component 180 might be configured for positioning relative to the component pads of the signal routes 160, 162. In one embodiment, one or more signal routes such as the signal route 160 can be configured to electrically couple two or more electrical components such as the component 180.

**[0028]** FIG. 2 shows a cross-sectional view of the assembly 100 taken along broken line 2-2 indicated in FIG. 1. The exemplary embodiment illustrated by FIG. 2 depicts the signal routes 160, 162 as being at least partially embedded in the dielectric material section 150. A person of ordinary skill in the art will appreciate that, in other embodiments, the signal routes 162, 166 can be fabricated on top of the second surface 154 of the dielectric material section 150. The

material of dielectric material section **150** can be selected to provide a solder non-wettable area for the solder connections **186, 188**, which can allow for improved solder handling during component mounting. Accordingly, a layer of solder resist on the dielectric material section **150** may be unnecessary. Alternatively, solder resist can be provided as a continuous layer or in selected locations.

[0029] FIG. 3 shows a plan view of a semiconductor assembly **300**. Back side **340** of die **310** is provided with dielectric material sections **352, 354**. In other embodiments, more than two dielectric material sections can be used. The sections can be located as desired, including as required by package requirements, e.g.: component size and functionality, as well as location and availability of lead fingers for wire bonding for components (including die). Although the sections **352, 354** are depicted as being generally rectangular, the size and shape of the sections **352, 354** can be modified as desired. In some embodiments, dielectric material sections such as the dielectric material sections **150** or **352, 354** can be configured to occupy substantially all of a die back side (e.g., die back side **140** as shown in FIG. 1), or they can be configured to leave a substantial area of a die back side unoccupied (e.g., area **356** of FIG. 3).

[0030] In some embodiments, electronic components such as the component **180** can comprise passive components (e.g., resistors, capacitors, inductors), active components (e.g., transistors, diodes), one or more additional semiconductor die, or combinations thereof. The signal routes can be configured according to a number of terminals of a selected electronic component, e.g., two pads can be fabricated for a two-terminal component such as a resistor, or three pads for a transistor. In further embodiments, more signal routes are fabricated on the dielectric material section **150** than are actually used by electronic components. For example, a generic design of the dielectric material section **150** can be manufactured for use with several embodiments using varying numbers and combinations of electronic components, with some embodiments using more signal routes than other embodiments.

[0031] FIG. 4 shows a plan view of another representative embodiment of a semiconductor assembly **400** comprising an integrated circuit die **410** having an active side **430** (not shown in this view) and a back side **440**. In this particular embodiment, the back side **440** features a metallization layer **442** comprising two or more signal routes **460, 462, 464, 466**, which can be similar to the signal routes of other embodiments described above. For example, the signal route **460** can comprise a component pad **470**, a signal trace **474** and a bond pad **472**. The signal routes **462, 464, 466** can comprise components similar to the signal route **460**, although the signal routes **460, 462, 464, 466** can vary in size and shape. The metallization layer **442** can be made of a suitable material, or combinations of suitable materials. In some embodiments, the metallization layer **442** is made of copper or one or more other metals. The metallization layer **442** can be formed by applying a metallization coating to the die back side **440**, followed by selectively etching the back side. In another embodiment, a metallization coating can be selectively applied with a mask during a coating process. One or more electronic components **480** can be electrically coupled to one or more component pads, e.g., the component pad **470** on the signal route **460**. The component can be coupled to the pad using one or more methods known in the art, such as surface-mount technology (SMT). In one

embodiment, one or more signal routes **460, 462, 464, 466** can be configured to electrically connect two or more electrical components **480** to each other. Dotted line **482** exemplifies where an electronic component **484** (shown in FIG. 5) might be positioned relative to the signal routes **460, 462**.

[0032] FIG. 5 shows a side cross-sectional view of assembly **400** taken along the broken line 5-5 indicated in FIG. 4. Relative to FIG. 4, FIG. 5 depicts an additional electronic component **484**, as well as solder **486, 488** used to attach the components **480, 484** to their respective signal routes **464, 462**. The surface area of die back side **440** that is not covered by the metallization layer **442** (e.g., not covered by signal routes **460**) can act as a solder non-wettable area. Thus an additional solder resist layer on die back side **440** can be unnecessary. Alternatively, solder resist can be provided as a continuous layer or in selected locations. In one embodiment, no passivation layer is added to the die back side **440** (e.g., on top of the metallization layer **442**), as the silicon of the die is non-conductive.

[0033] As was discussed with respect to similar assemblies **100, 300**, the electronic components **480, 484** can comprise passive components (e.g., resistors, capacitors, inductors), active components (e.g., transistors, diodes), or combinations thereof. In other embodiments, the components **480, 484** comprise additional semiconductor die. The component pads can be configured according to a number of terminals of a selected electronic component, e.g., two pads can be fabricated for a two-terminal component such as a resistor, or three pads for a transistor. In some embodiments, more component pads are fabricated in the metallization layer than are actually used by electronic components electrically coupled to the metallization layer. For example, a generic arrangement and number of component pads can be manufactured in the metallization layer for use with multiple embodiments using varying numbers and combinations of electronic components, with some embodiments using more component pads than other embodiments.

[0034] FIG. 6 shows a plan view of one embodiment of an assembly **600** combining some features of assemblies **100, 300** and **400**. For example, a semiconductor die **610** can comprise an active side **630** (shown in FIG. 7) and a back side **640** with a dielectric material section **654** occupying a portion of the backside **640**. The dielectric material section **654** can have one or more signal routes **660, 662** to which an electronic component **680** can be attached. The back side of the same die also can feature one or more signal routes **664, 666** fabricated in a metallization layer **642**. An electronic component **682** can be attached to the signal routes **664, 666**. FIG. 7 shows a side cross-sectional view of the assembly **600**, taken along the broken line 7-7 in FIG. 6. As shown in FIG. 7, the components **680, 682** can be coupled to the signal routes **660, 666** with respective solder connections **686, 688**.

[0035] FIG. 8 shows a plan view of one embodiment of a die **810** in a flip chip package **800**. Die **810** is depicted as being similar to the die **310** of assembly **300** of FIG. 3, with the dielectric material sections **852, 854** attached to the die back side **840**. Additional die embodiments disclosed herein, and embodiments similar thereto also can be packaged in a similar manner. The flip chip package **800** comprises a die paddle **812** and a plurality of leads **814**. One or more

electronic components **880** can be electrically coupled to the leads **814** via one or more signal routes **860** and one or more wires **882**.

[0036] FIG. 9 shows a side cross-sectional view of the chip package **800**, taken along the line 9-9 in FIG. 8. This view more clearly shows packaging material **884** which can encapsulate some or all of the die **810**, the die paddle **812**, the leads **814** and the electronic components **880**. (Packaging material **884** also appears in FIG. 8 in spaces around the leads **814** and the die paddle **812**, but the material positioned above the paddle **812** and the die **810** is not shown, to provide a clear view of those components.) A number of materials known in the art can be used for the packaging material **884**. In some embodiments one packaging material **884** is used, and in other embodiments two or more materials **884** are used. The chip package **800** can further comprise bumps **820**, which can provide an electrical coupling between the active side **830** of the die **810** and the one or more leads **814**. The bumps **820** can be arranged in a variety of positions, as is known in the art, and can be coupled to one or more bonding pads (not shown) on the die active side **830**. The leads **814**, bumps **820**, wires **882** and signal routes **860** can provide one or more electrical connections between the active side **830** and the electronic components **880**.

[0037] Placing the electronic components **880** on the back side **840** of the die **810** can allow for incorporating such components into the chip package **800** without necessarily increasing the area of the package **800**. In some embodiments, a first group of one or more electronic components **880** is placed on the back side **840**, while a second group of the one or more electronic components **880** is placed approximately coplanar to the die **810** (e.g., on the leads **814**).

[0038] In some embodiments, the chip package **800** can be incorporated into a chip-scale package (CSP), a ball-grid array (BGA) package, a direct chip array (DCA) package, a multi-chip module (MCM), package-on-package (PoP), package-in-package (PiP), or other packages known in the art.

[0039] FIG. 10 depicts a plan view of one embodiment of a bond-on-lead (BOL) package **1000**, the exterior of which comprises leads **1014** and at least one packaging material **1084**. FIG. 11 shows a cross-sectional side view of the BOL package **1000**, taken along the line 11-11 in FIG. 10. The depicted embodiment is a wirebond design, although in other embodiments a flip chip design can be used with a BOL package. In the depicted embodiment, the semiconductor die **1010** can be configured similarly to the die **110** of the assembly **100**. (Other embodiments described above can also be used with a BOL package.) Dielectric material **1050**, featuring one or more electronic components **1086**, can be attached to the back side **1040** of the die **1010**. Wires **1082** can electrically couple electronic components **1086** with one or more leads **1014**. Wires **1088** can electrically couple the active side **1030** of the die **1010** with leads **1014**. A configuration of the wires **1082**, **1088** and the leads **1014** can electrically couple the components **1086** with the active side **1030**.

[0040] FIG. 12 shows a flowchart for one embodiment of a method **1200** for making a semiconductor assembly. A semiconductor die can be provided (step **1210**) and two or more component pads can be provided (step **1220**). As is explained below, the component pads can be provided on a dielectric material section or in a metallization layer. One or

more electronic components can be electrically coupled with two or more component pads (step **1230**). In some embodiments, leads and packaging materials can be provided (step **1240**), which can result in packages similar to packages **800** and **1000** as described above, for example.

[0041] FIG. 13 shows a flowchart for one embodiment of a method **1300** for making a semiconductor assembly similar to assemblies **100**, **300**, as described above. In step **1310**, a semiconductor die can be provided. One or more dielectric material sections can be provided (step **1320**) and attached to the back side of the die (step **1330**). Component pads can be formed on the one or more dielectric material sections (step **1340**), and one or more electronic components can be electrically coupled with the component pads (step **1350**). In some embodiments, leads and packaging materials can be provided (step **1360**), which can result in packages similar to packages **800** and **1000** as described above, for example.

[0042] FIG. 14 shows a flowchart for one embodiment of a method **1400** for making a semiconductor assembly similar to assembly **400**, as described above. In step **1410**, a semiconductor die can be provided. A metallization layer can be provided on the back side of the die using, for example, the methods described above with respect to assembly **400** (step **1420**). The metallization layer can comprise a plurality of component pads, as well as signal traces and wirebond pads. Electronic components can be electrically coupled with at least some of the component pads (step **1430**). In some embodiments, leads and packaging materials can be provided (step **1440**), which can result in packages similar to packages **800** and **1000** as described above, for example.

[0043] Although the steps described above in methods **1200**, **1300** and **1400** can be executed in the order described, some embodiments can carry out some steps in one or more different orders. For example, in method **1300**, component pads can be formed on the one or more dielectric material sections (step **1340**) before the sections are attached to the die back side (step **1330**). Those of ordinary skill in the art will recognize other possible orders for the disclosed methods.

[0044] In view of the many possible embodiments to which the principles of the disclosed invention may be applied, it should be recognized that the illustrated embodiments are only preferred examples of the invention and should not be taken as limiting the scope of the invention. Rather, the scope of the invention is defined by the following claims. We therefore claim as our invention all that comes within the scope and spirit of these claims.

We claim:

1. A semiconductor assembly, comprising:
  - a semiconductor die having an active side and a back side;
  - a dielectric material section having a first side and a second side, wherein the first side is attached to the back side of the semiconductor die;
  - a plurality of component pads attached to the second side of the dielectric material section; and
  - one or more electronic components electrically coupled with one or more of the component pads.
2. The semiconductor assembly of claim 1, wherein at least one of the one or more electronic components is a passive component.
3. The semiconductor assembly of claim 1, further comprising a plurality of signal traces electrically coupled with the plurality of component pads.

4. The semiconductor assembly of claim 1, further comprising a plurality of bond pads electrically coupled with the plurality of component pads.

5. The semiconductor assembly of claim 1, wherein the dielectric material section comprises a first section of dielectric material and a second section of dielectric material.

6. The semiconductor assembly of claim 1, wherein at least one of the one or more electronic components has exactly two terminals.

7. The semiconductor assembly of claim 1, wherein at least one of the electronic components is electrically coupled with a component pad via a solder connection, and wherein the dielectric material section provides a solder non-wettable area for the solder connection.

8. The semiconductor assembly of claim 1, wherein the dielectric material section exposes a substantial portion of the back side of the semiconductor die.

9. The semiconductor assembly of claim 1, further comprising a metallization layer having a first side and a second side, the first side being attached to the die back side, wherein the metallization layer comprises a plurality of component pads.

10. The semiconductor assembly of claim 1, wherein the assembly is packaged in a flip chip package.

11. The semiconductor assembly of claim 1, further comprising a die paddle and a packaging material, the packaging material at least partially encompassing the semiconductor die.

12. A semiconductor assembly, comprising:  
a semiconductor die having an active side and a back side;  
a metallization layer having a first side and a second side, the first side being attached to the die back side, wherein the metallization layer comprises a plurality of component pads; and  
one or more discrete electronic components electrically coupled with at least two of the plurality of component pads.

13. The semiconductor assembly of claim 12, wherein the one or more discrete electrical components are passive components.

14. The semiconductor assembly of claim 12, wherein the second side of the metallization layer is not in contact with a passivation layer.

15. The semiconductor assembly of claim 12, further comprising a plurality of signal traces electrically coupled with the plurality of component pads.

16. The semiconductor assembly of claim 12, further comprising a plurality of bond pads electrically coupled with the plurality of component pads.

17. The semiconductor assembly of claim 12, wherein the metallization layer is a selective metallization coating with a mask or a selectively etched metallization coating.

18. The semiconductor assembly of claim 12, wherein at least one of the electronic components is attached to the component pads via a plurality of solder connects, and wherein the die back side provides a solder non-wettable area for at least one of the solder connects.

19. A method of making a semiconductor assembly, the method comprising:

- providing a semiconductor die having an active side and a back side;
- providing a dielectric material section having a first side and a second side;
- attaching the first side of the dielectric material section to the back side of the semiconductor die;
- forming a plurality of component pads on the second side of the dielectric material section; and
- electrically coupling one or more electronic components with at least two of the plurality of component pads.

20. The method of claim 19, wherein at least one of the electronic components is a passive component.

21. The method of claim 19, wherein the dielectric material section comprises a first dielectric material section and a second dielectric material section.

22. The method of claim 19, wherein electrically coupling one or more electronic components with at least two of a plurality of component pads comprises creating one or more solder connections between the electronic components and the component pads, and wherein the dielectric material section provides a solder non-wettable area for the solder connection.

23. The method of claim 19, further comprising encapsulating at least part of the semiconductor die with one or more packaging materials.

24. A method of making a semiconductor assembly, the method comprising:

- providing a semiconductor die having an active side and a back side;
- providing a metallization layer having a first side and a second side, the first side being attached to the die back side, wherein the metallization layer comprises a plurality of component pads; and
- electrically coupling one or more discrete electronic components with at least two of the plurality of component pads.

25. The method of claim 24, wherein at least one of the discrete electronic components is a passive component.

26. The method of claim 24, wherein the second side of the metallization layer is not in contact with a passivation layer.

\* \* \* \* \*