



US 20110304999A1

(19) **United States**

(12) **Patent Application Publication**  
Yu et al.

(10) **Pub. No.: US 2011/0304999 A1**

(43) **Pub. Date: Dec. 15, 2011**

(54) **INTERPOSER-ON-GLASS PACKAGE STRUCTURES**

**Publication Classification**

(75) Inventors: **Chen-Hua Yu, Hsin-Chu (TW);  
Jing-Cheng Lin, Hsin-Chu (TW)**

(51) **Int. Cl.**  
*H05K 1/18* (2006.01)  
*H05K 3/00* (2006.01)  
*H05K 1/11* (2006.01)

(73) Assignee: **Taiwan Semiconductor Manufacturing Company, Ltd.,  
Hsin-Chu (TW)**

(52) **U.S. Cl. .... 361/783; 174/266; 29/829**

(21) Appl. No.: **12/834,943**

(57) **ABSTRACT**

(22) Filed: **Jul. 13, 2010**

**Related U.S. Application Data**

(60) Provisional application No. 61/353,580, filed on Jun. 10, 2010.

A device includes an interposer including a substrate, and a first through-substrate via (TSV) penetrating through the substrate. A glass substrate is bonded to the interposer through a fusion bonding. The glass substrate includes a second TSV therein and electrically coupled to the first TSV.

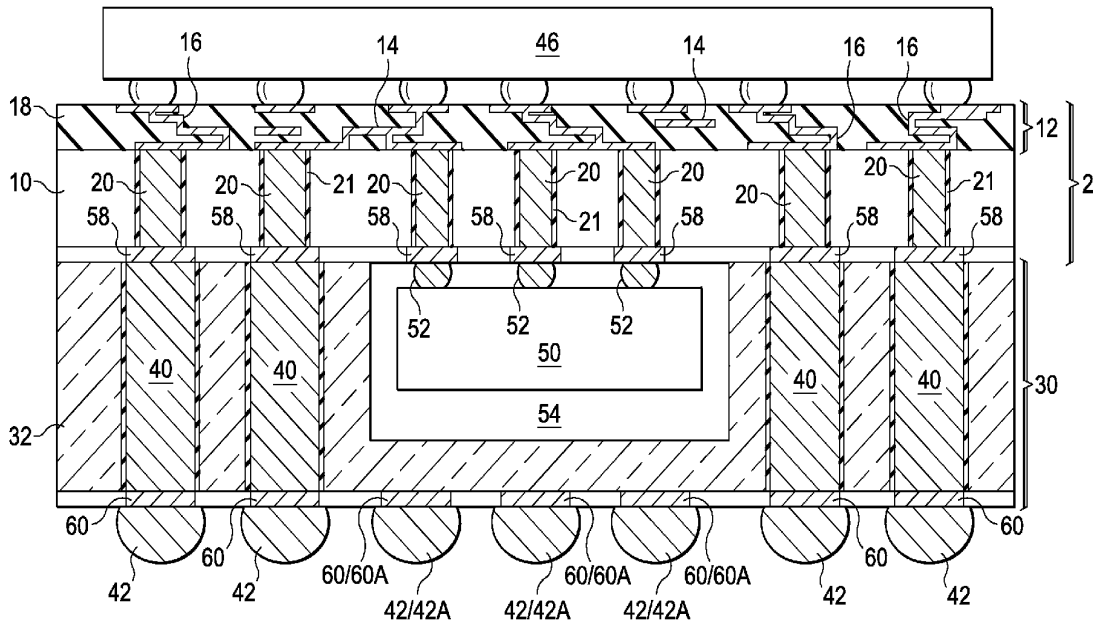

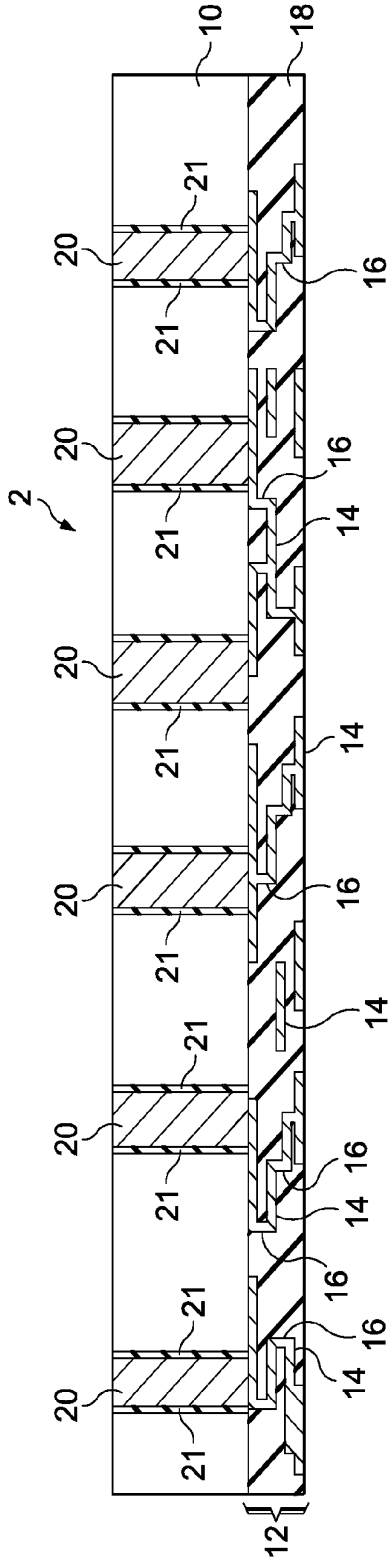

FIG. 1A

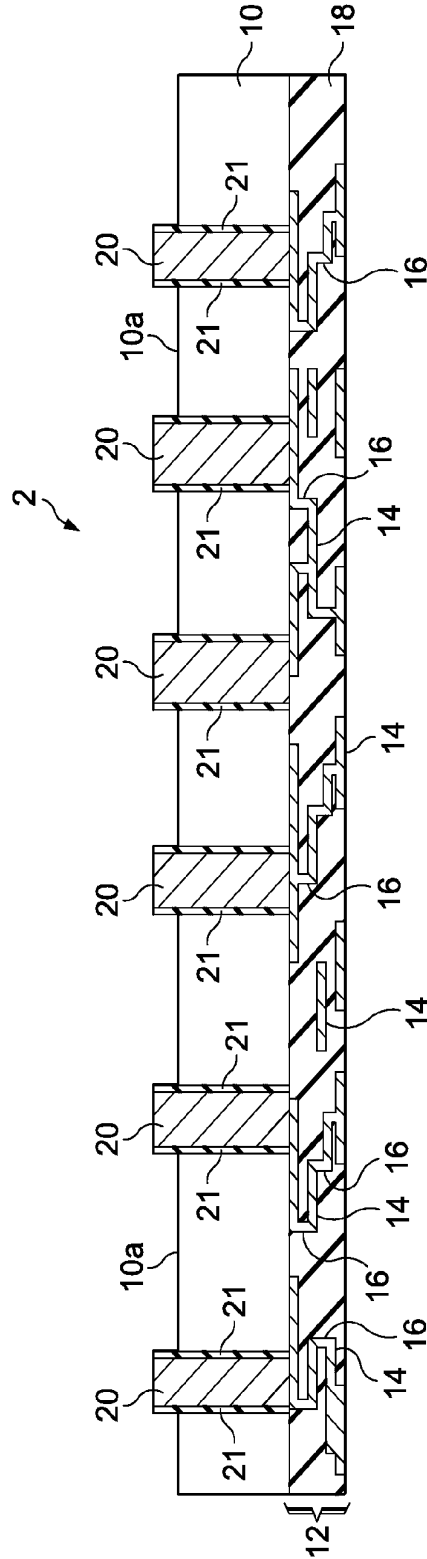

FIG. 1B

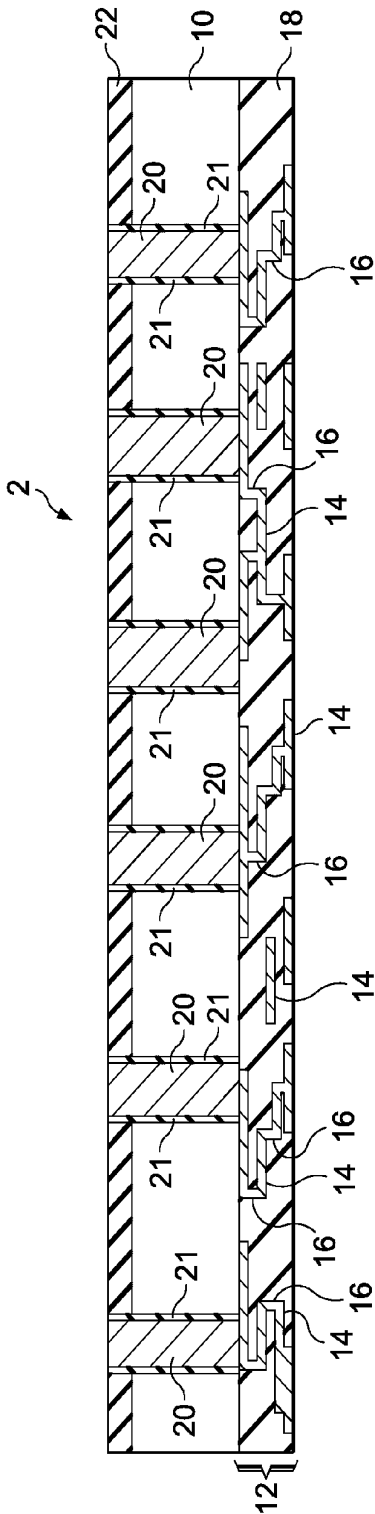

FIG. 1C

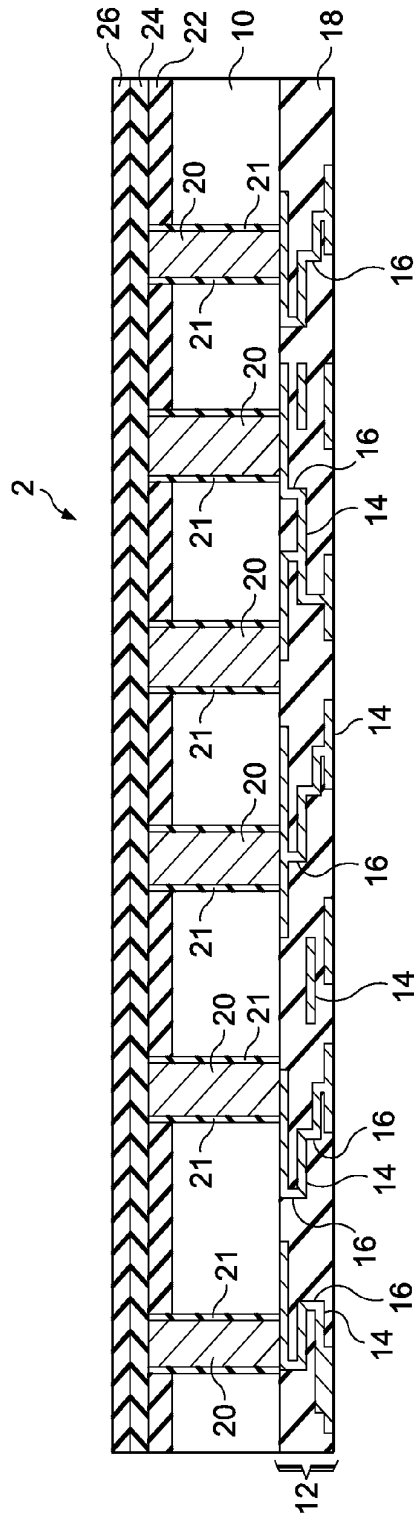

FIG. 1D

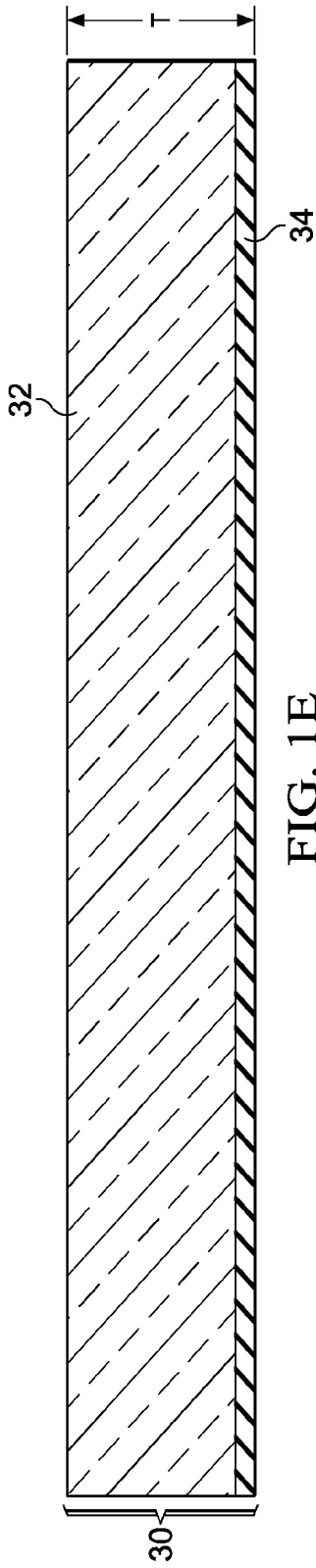

FIG. 1E

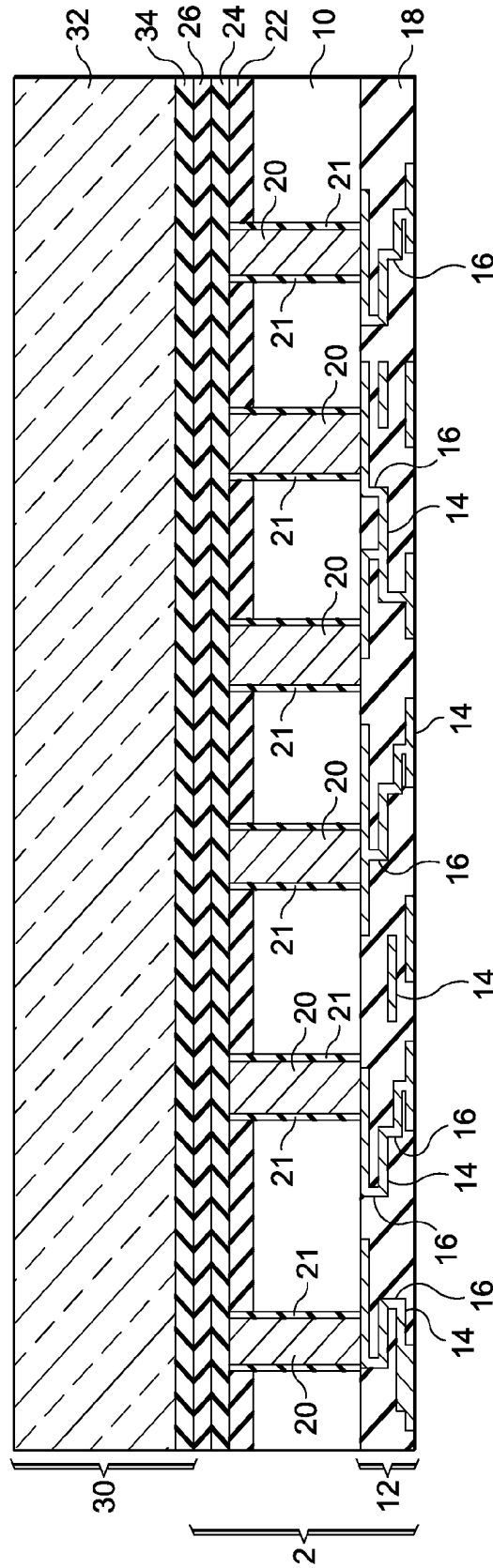

FIG. 1F









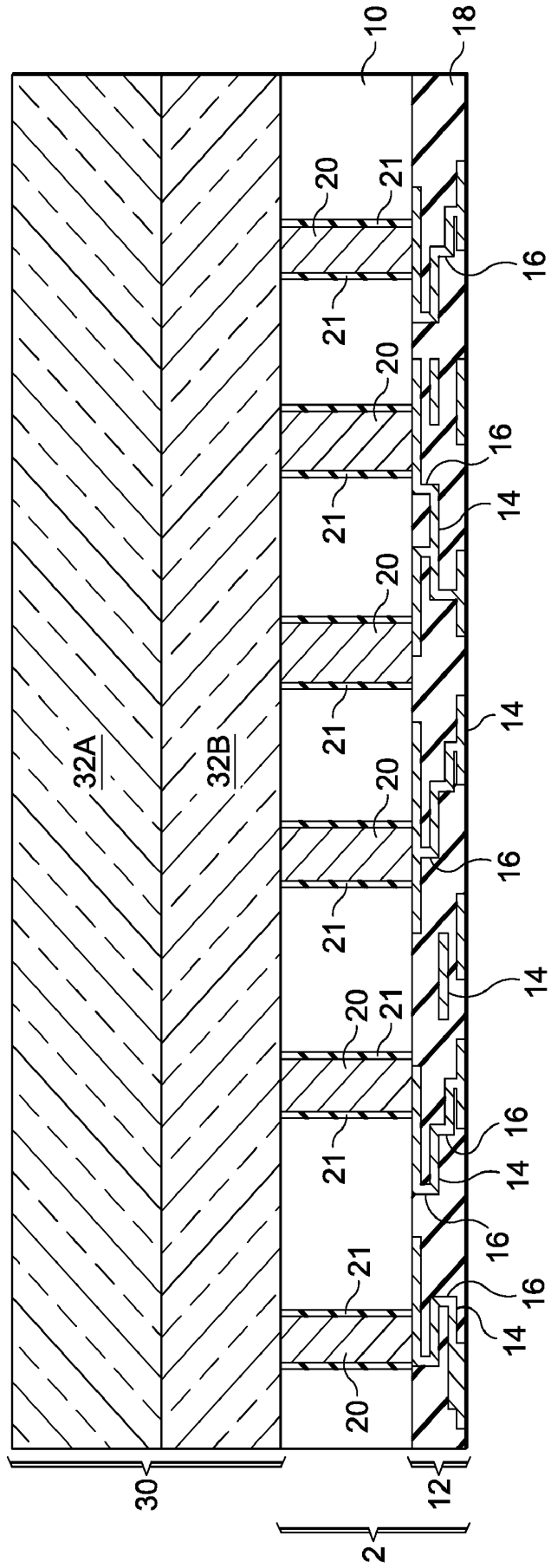

FIG. 2A

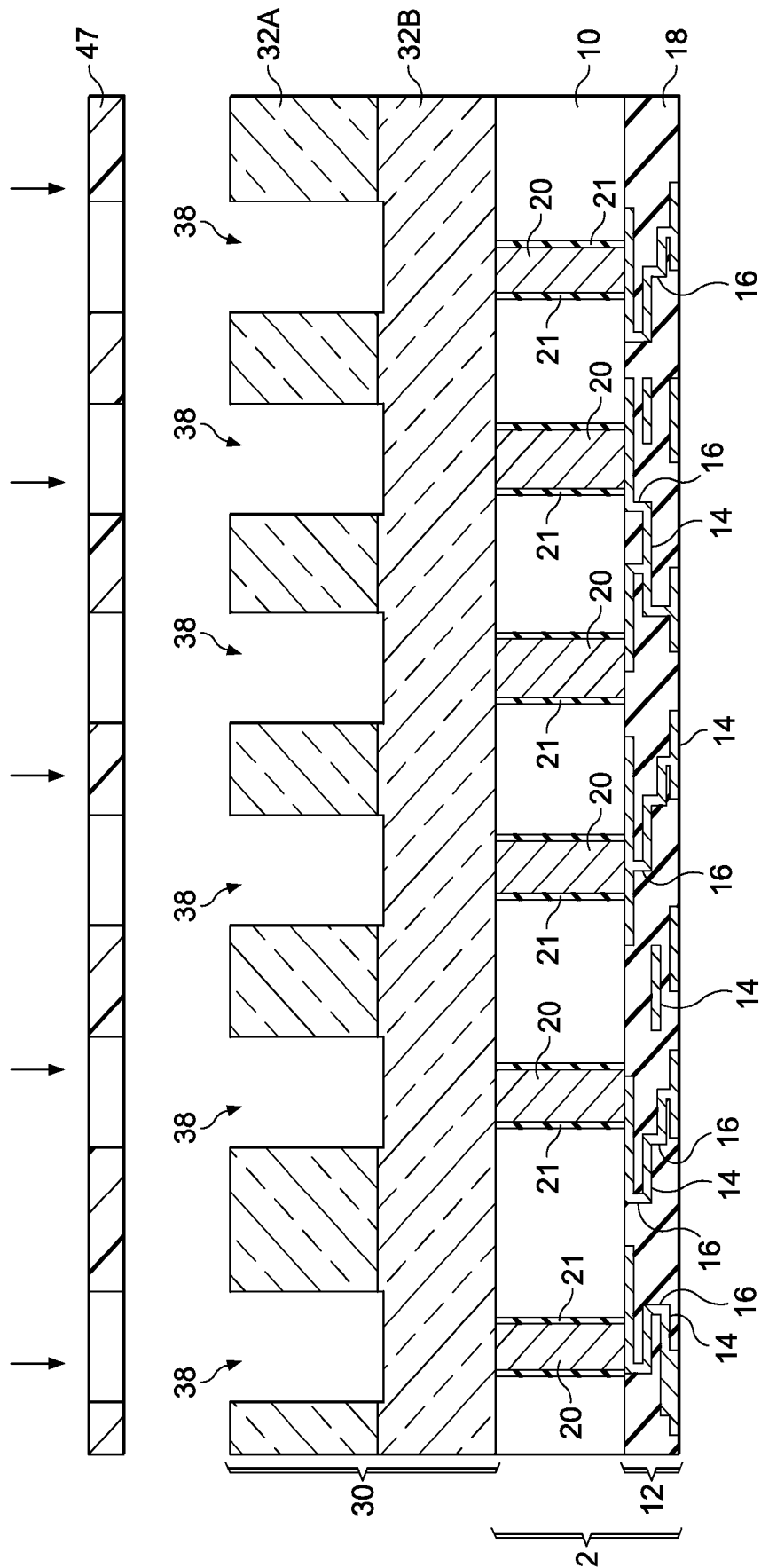

FIG. 2B

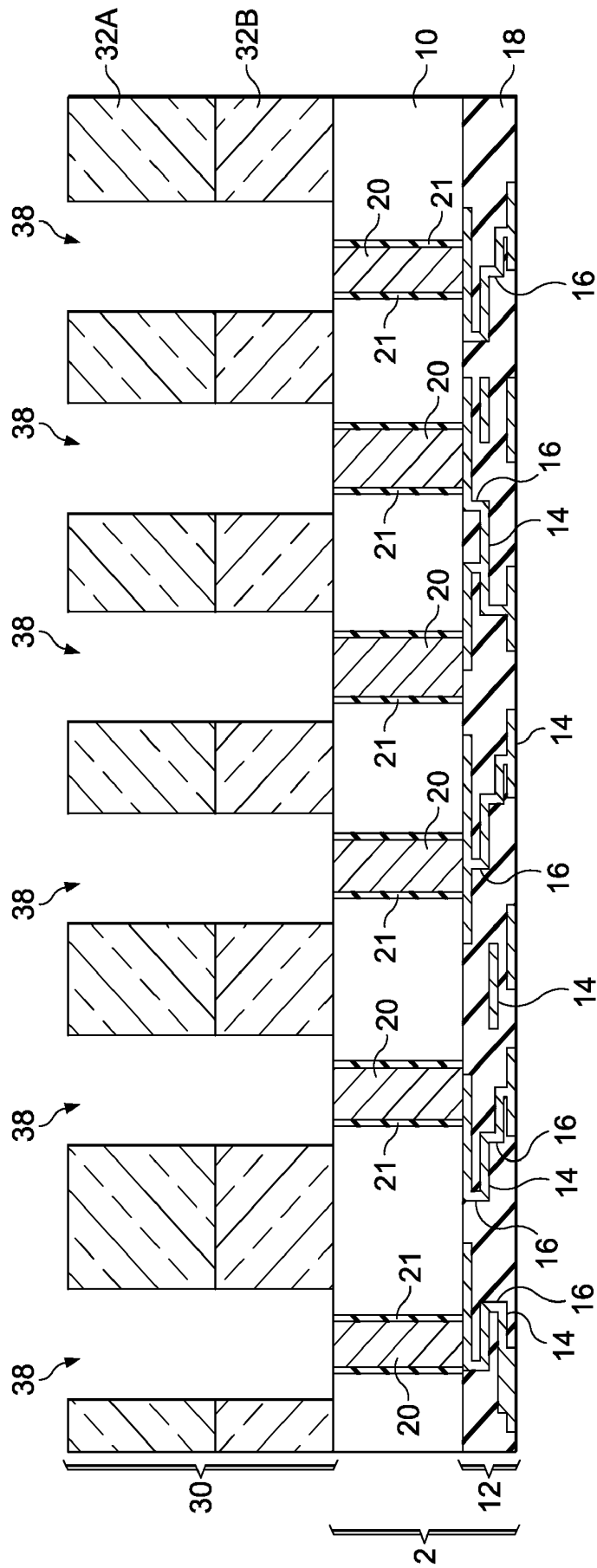

FIG. 2C

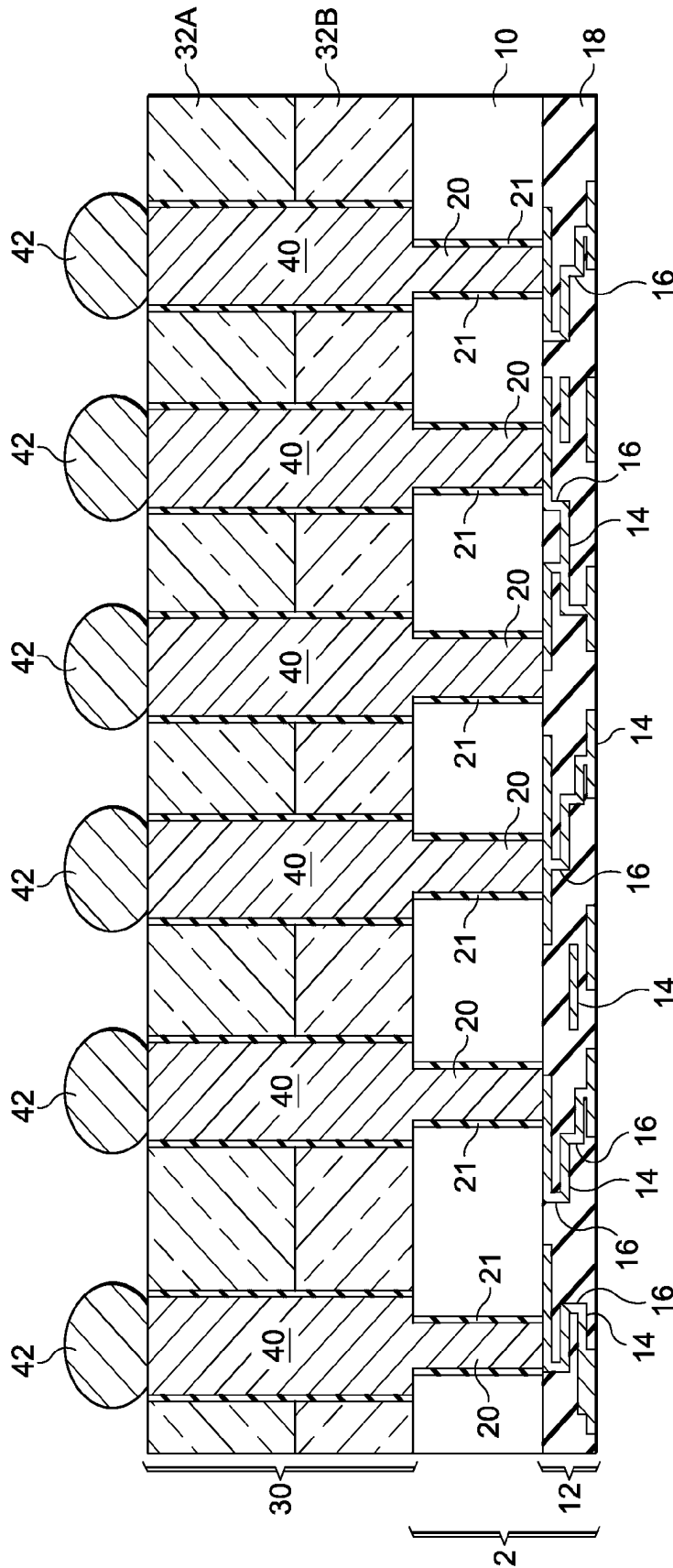

FIG. 2D





FIG. 5

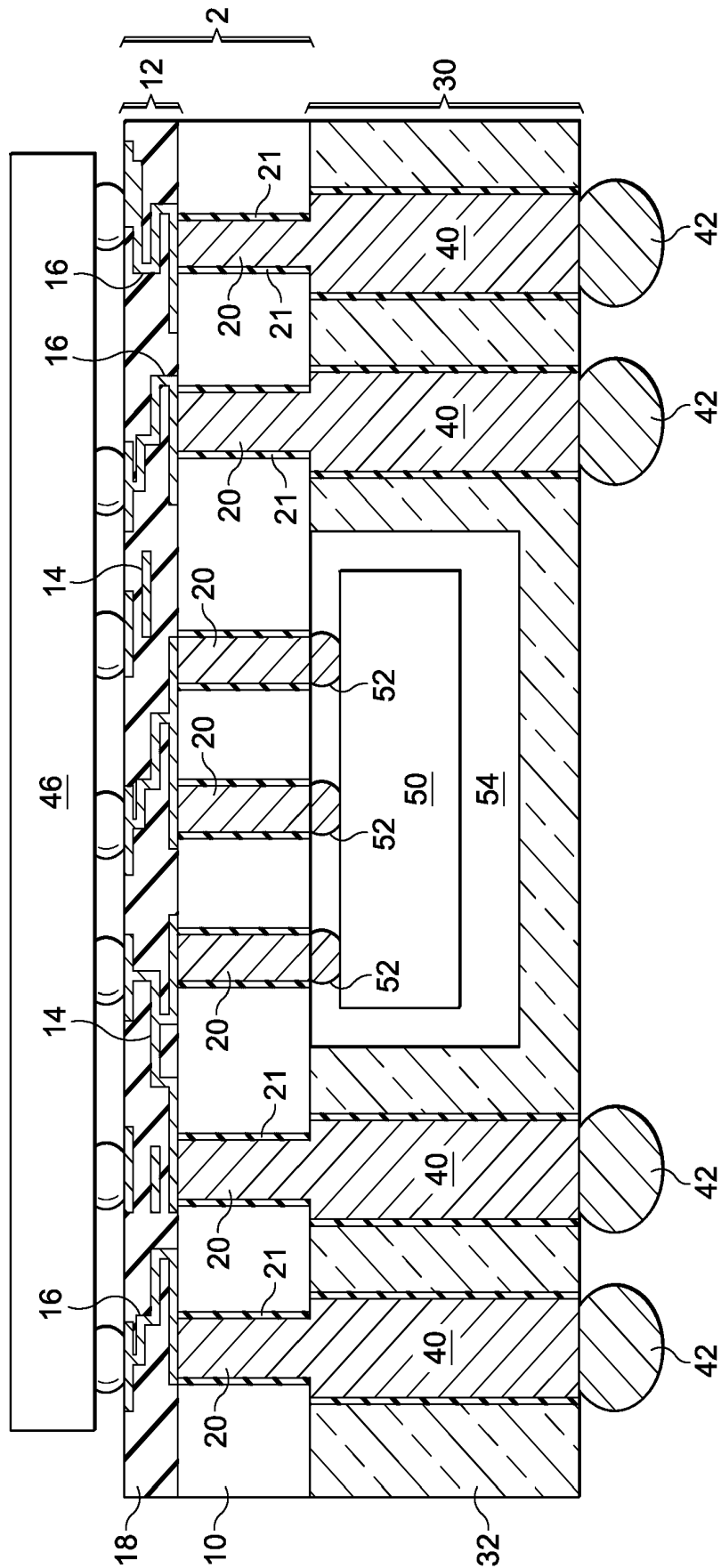

FIG. 6

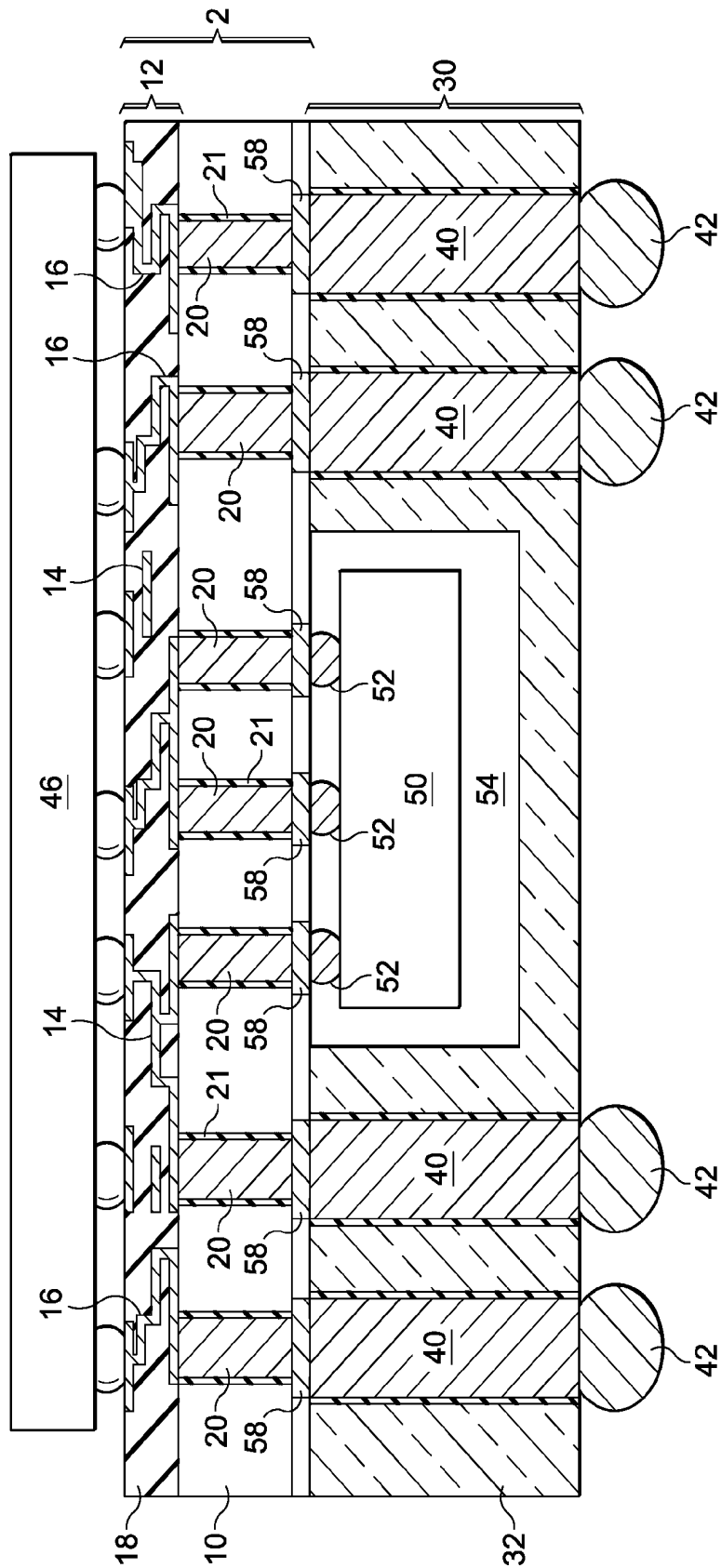

FIG. 7

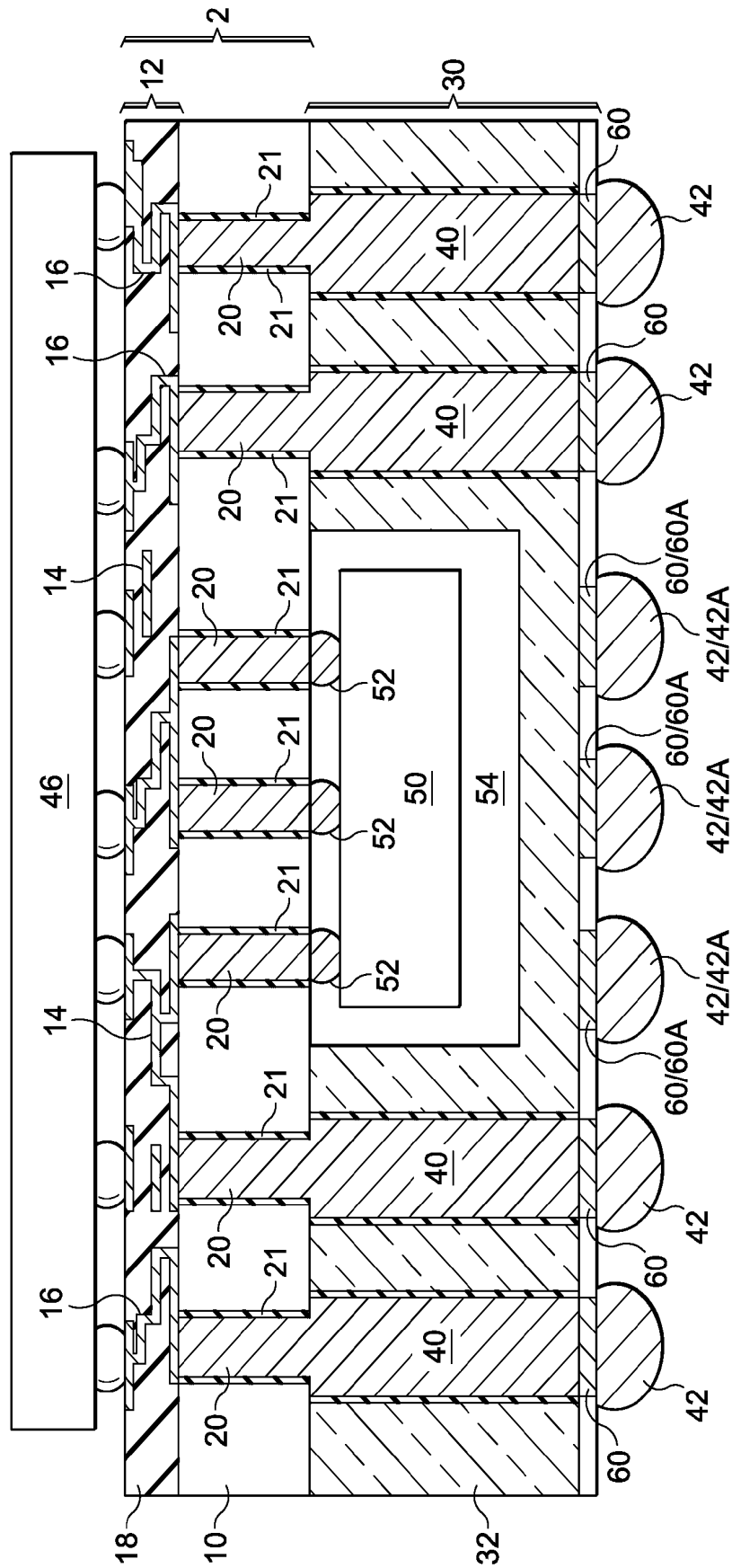
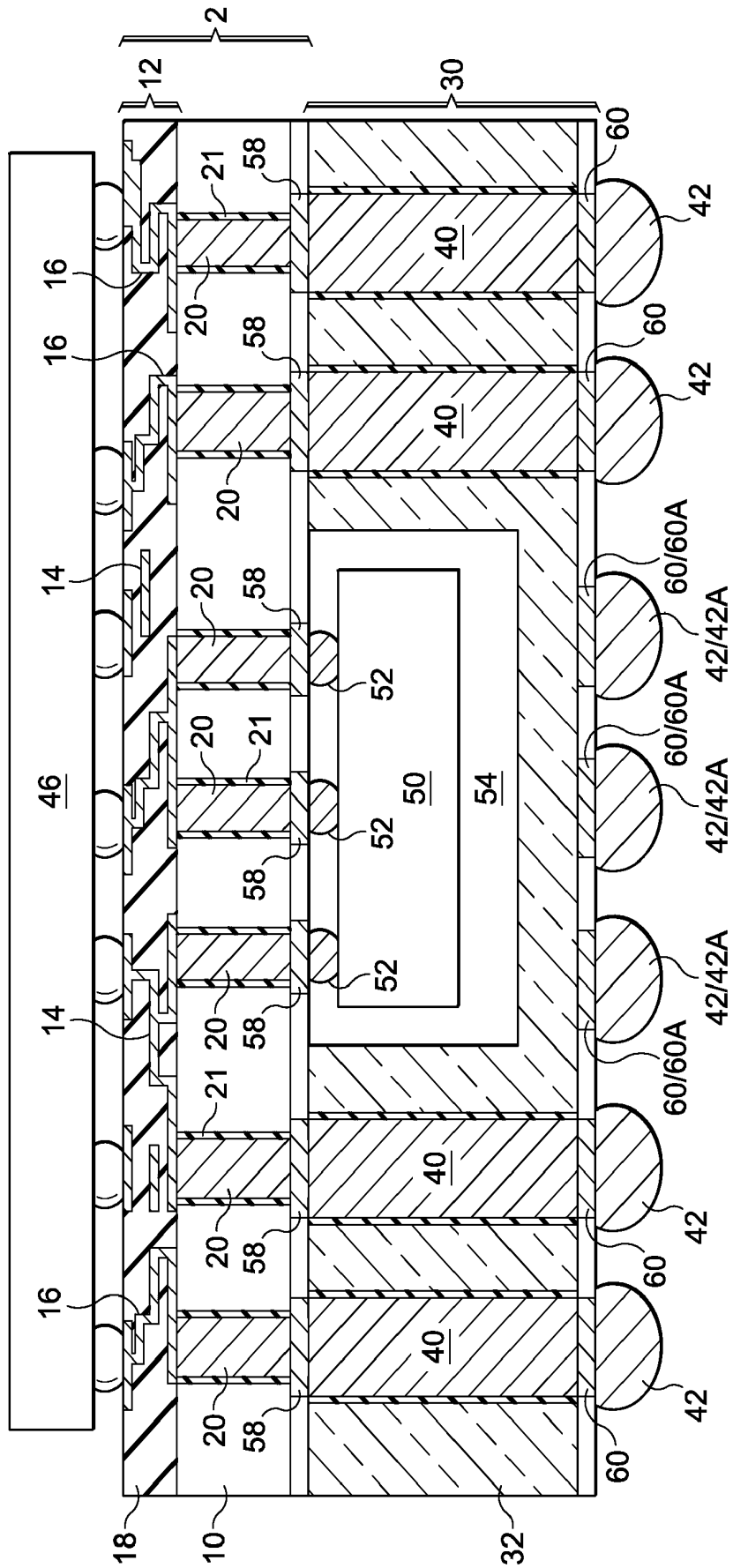

FIG. 8



## INTERPOSER-ON-GLASS PACKAGE STRUCTURES

### TECHNICAL FIELD

[0001] This disclosure relates generally to integrated circuit structures, and more particularly to interposer-on-glass package structures and methods for forming the same.

### BACKGROUND

[0002] To increase the density of package structures, multiple dies may need to be packaged in a same package structure. To accommodate multiple dies, an interposer is typically used to bond dies thereon, and the resulting structure including the interposer and the dies are treated as a single structure.

[0003] It is desirable to form silicon interposers due to the fact that the technology for handling silicon substrates is mature. Further, features formed on silicon interposers may have a high density. However, due to various factors, such as the significant difference between the coefficient of thermal expansion (CTE) of silicon and the CTE of printed circuit board (PCB), it is difficult to bond a silicon interposer directly on a PCB without incurring reliability issues. For example, dies are bonded on a silicon interposer, which are bonded to PCB directly, the resulting package structure will suffer from reliability problems. A solution for the above-discussed problem is to insert an organic substrate between silicon interposer and PCB. This solution, however, still suffers from other issues. Firstly, organic substrates have a high cost. Secondly, organic substrates are typically soft, and hence may not be able to provide enough protection needed by other package components. Thirdly, the signal loss in organic substrates is high, particularly when the signal has a high frequency.

### SUMMARY

[0004] In accordance with one aspect, a device includes an interposer including a substrate, and a first through-substrate via (TSV) penetrating through the substrate. A glass substrate is bonded to the interposer through a fusion bonding. The glass substrate includes a second TSV therein and electrically coupled to the first TSV.

[0005] Other embodiments are also disclosed.

### BRIEF DESCRIPTION OF THE DRAWINGS

[0006] For a more complete understanding of the embodiments, and the advantages thereof, reference is now made to the following descriptions taken in conjunction with the accompanying drawings, in which:

[0007] FIGS. 1A through 1J are cross-sectional views of intermediate stages in the manufacturing of a package structure in accordance with an embodiment, wherein a glass substrate is bonded to an interposer;

[0008] FIGS. 2A through 2D are cross-sectional views of intermediate stages in the manufacturing of a package structure in accordance with alternative embodiments, wherein a composite glass substrate is bonded to an interposer; and

[0009] FIGS. 3 through 8 illustrate package structures in accordance with various embodiments, wherein openings are formed in glass substrates, with dies located in the openings.

### DETAILED DESCRIPTION OF ILLUSTRATIVE EMBODIMENTS

[0010] The making and using of the embodiments of the disclosure are discussed in detail below. It should be appreciated, however, that the embodiments provide many applicable inventive concepts that can be embodied in a wide

variety of specific contexts. The specific embodiments discussed are merely illustrative, and do not limit the scope of the disclosure.

[0011] A novel package structure incorporating glass substrates and the method of forming the same are provided. The intermediate stages of manufacturing various embodiments are illustrated. The variations of the embodiments are then discussed. Throughout the various views and illustrative embodiments, like reference numbers are used to designate like elements.

[0012] Referring to FIG. 1A, interposer wafer 2, which includes substrate 10 and interconnect structure 12, is provided. Substrate 10 may be formed of a semiconductor material such as silicon. Alternatively, substrate 10 is formed of a dielectric material. Interposer wafer 2 is substantially free from integrated circuit devices, including active devices such as transistors and diodes. Furthermore, interposer wafer 2 may include, or may be free from, passive devices such as capacitors, resistors, inductors, varactors, and/or the like.

[0013] Interconnect structure 12 is formed on substrate 10. Interconnect structure 12 includes one or more dielectric layer 18, and metal lines 14 and vias 16 in dielectric layer(s) 18. Throughout the description, the side of interposer wafer 2 with interconnect structure 12 is referred to as a front side, and the opposite side is referred to as a backside. Metal lines 14 and vias 16 are referred to as front-side redistribution lines (RDLs). Further, through-substrate vias (TSVs) 20 are formed in substrate 10, and are electrically coupled to front-side RDLs 14/16. Insulation layers 21 are used to separate TSVs 20 from substrate 10.

[0014] Referring to FIG. 1B, substrate 10 is etched, so that TSVs 20 protrude out of the backside surface 10a of substrate 10. Etch stop layer 22, which may be formed of silicon nitride, for example, is formed on TSVs 20 and substrate 10, and is polished or etched to form the structure as shown in FIG. 1C, wherein TSVs 20 are again exposed. Next, as shown in FIG. 1D, etch stop layer 24, which may also be formed of silicon nitride, for example, is formed on etch stop layer 22. Next, oxide layer 26, which may be a silicon oxide (SiO) layer, is formed. The formation methods of etch stop layers 22/24 and oxide layer 26 include commonly used deposition methods such as plasma enhance chemical vapor deposition (PECVD). In alternative embodiments, additional RDLs 58 (not shown in FIG. 3D, please refer to FIGS. 6 and 8) may be formed on the back side of substrate 10, wherein one or more layer of RDLs 58 may be formed.

[0015] FIG. 1E illustrates glass substrate 30, which includes glass layer 32. Glass layer 32 may be formed of SiO<sub>2</sub>, LiO<sub>2</sub>, CeO<sub>2</sub>, Al<sub>2</sub>O<sub>3</sub>, B<sub>2</sub>O<sub>3</sub>, or the like. Optionally, oxide layer 34 such as silicon oxide (SiO) may be formed on the surface of glass layer 32. In an embodiment, thickness T of glass substrate 30 is less than about 800 μm, or even less than about 200 μm.

[0016] Next, as shown in FIG. 1F, glass substrate 30 is bonded to interposer wafer 2 through the fusion bond (oxide-to-oxide bond). In an embodiment wherein oxide layer 34 is formed, oxide layer 34 is bonded to oxide layer 26. In alternative embodiments wherein the glass in glass layer 32 itself is also an oxide, or the surface of glass layer 32 is oxidized, oxide layer 34 is not formed, and glass layer 32 is bonded to, and contacts, oxide layer 26 directly.

[0017] Referring to FIG. 1G, photo resist 36 is formed on glass substrate 30, and is patterned. Openings 38 are then formed by etching glass substrate 30 and underlying layers 24, 26, and 34, until TSVs 20 are exposed. During the etching step, etch stop layer 24 functions to stop the etching process, and is then etched to expose TSVs 20.

[0018] Next, as shown in FIG. 1H, TSVs 40 are formed in openings 38, and may be electrically coupled to TSVs 20. In an embodiment, the lateral dimension W1, which may be a length/width or a diameter, depending on the top-view shape of TSVs 40, is greater than lateral dimension W2 of TSVs 20. The formation of TSVs 40 may include a plating process for fill openings 38 with a metallic material such as copper, tungsten, a solder material, or the like, and then performing a chemical mechanical polish (CMP) to remove excess portions of the metallic material over glass substrate 30.

[0019] FIG. 1I illustrates the formation of solder bumps 42 over glass substrate 30 and electrically coupled to TSVs 40. The resulting package structure as shown in FIG. 31 may then be sawed apart, resulting in a plurality of package structures. FIG. 1J illustrates one of the resulting package structures, wherein an interposer (a piece sawed from interposer wafer 2) is also denoted using reference numeral 2, while a piece of glass substrate that is a piece of glass substrate 30 is also denoted using reference numeral 30. Solder bumps 42 in the resulting package structure may be bonded to printed circuit board (PCB) 48 or other package components such as a package substrate. Further, interconnect structure 12 of interposer 2 may be bonded to die(s) 46.

[0020] FIGS. 2A through 2D illustrate alternative embodiments. Unless specified otherwise, the reference numerals in embodiments shown in FIGS. 2A through 10 represent like elements in the embodiments illustrated in FIGS. 1A through 1J. For simplicity, the detailed structures such as layers 22, 24, 26, and 34, which are involved in the bonding between glass substrate 30 and interposer wafer 2 (as shown in detail in FIGS. 1A through 1F) are not illustrated, although these structures may also be used in all embodiments throughout the disclosure. The initial steps of this embodiment is essentially the same as shown in FIGS. 1A through 1F, except glass layer 32 is a composite glass substrate comprising photo-sensitive glass layer 32A, and non-photo-sensitive glass layer 32B, wherein the resulting bonded structure is shown in FIG. 2A. Referring to FIG. 2B, photo-sensitive glass layer 32A is exposed to light using lithography mask 47, for example. In an embodiment, the portions of photo-sensitive glass layer 32A that are subject to the light exposure (symbolized by arrows) are removed, while the portions not exposed to light are not removed. In alternative embodiments, the portions of photo-sensitive glass layer 32A that are not subject to the light exposure (symbolized by arrows) are removed, while the portions exposed to light are not removed. Referring to FIG. 2C, the patterned photo-sensitive glass layer 32A acts as a hard mask for the etching of underlying non-photo-sensitive glass layer 32B, and hence the resulting openings 38 extend to TSVs 20.

[0021] Next, as shown in FIG. 2D, TSVs 40 are formed, and bumps 42 are formed to electrically couple to TSVs 40. Processes are then continued, in which the package structure as shown in FIG. 4D is sawed, and a package component (not shown in FIG. 2D, please refer to package component 48 in FIG. 1J) such as a package substrate or a PCB is bonded to bumps 42. Further, die(s) 46 (not shown in FIG. 2D, please refer to FIG. 1J) may be bonded to interconnect structure 12. The process steps are essentially the same as shown in FIG. 1J, and are not discussed herein.

[0022] FIGS. 3 through 8 illustrate variations of the embodiments. Again, the formation details of layers 22/24/26/34 as shown in FIG. 1F of these embodiments are not shown, and may be realized by applying the teaching as shown in FIGS. 1A through 1E. Referring to FIG. 3, die 50 is directly bonded to interposer 2 (which is a piece sawed from interposer wafer 2 as shown in FIG. 1I) through bumps 52.

Die 50 may be located in opening 54 (alternatively referred to as a pocket) in glass substrate 30, wherein opening 54 may be a through-opening penetrating from one side to the opposite side of glass substrate 30. Through-opening 54 may be pre-formed before glass substrate 30 is bonded to interposer wafer 2, or formed simultaneously with the formation of openings 38 (not shown in FIG. 3, please refer to FIG. 1G). FIG. 5 also illustrates that more than one die 46 may be bonded to interposer 2.

[0023] FIG. 4 illustrates yet another embodiment, wherein RDLs 58 are formed between interposer 2 and glass substrate 30. RDLs 58 may be pre-formed on interposer wafer 2 (or pre-formed on glass substrate 30) before interposer (wafer) 2 is formed on glass substrate 30. Although FIG. 4 only illustrates one layer of RDLs 58, more than one layer of RDLs may be formed. With the formation of RDLs 58, TSVs 40 do not have to be vertically aligned to TSVs 20. Instead, TSVs 40 and TSVs 20 can be fully or partially misaligned, and electrically coupled with each other through RDLs 58.

[0024] In FIG. 5, opening 54 extends only partially into glass substrate 30 and stops at an intermediate level of glass substrate 30. Die 50 is located in opening 54. In an exemplary embodiment for forming the structure, opening 54 is pre-formed in glass substrate 30 before interposer wafer 2 is bonded with glass substrate 30. Further, die 50 may be bonded to interposer wafer 2 before the bonding of interposer wafer 2 to glass substrate 30 is performed. Accordingly, after interposer wafer 2 and glass substrate 30 are bonded, die 50 is protected by glass substrate 30. FIG. 6 illustrates a package structure similar to the structure shown in FIG. 5, except RDLs 58 are further formed.

[0025] FIGS. 7 and 8 illustrate package structures similar to the package structures shown in FIGS. 5 and 6, respectively, with additional RDLs 60 formed on the surface of glass substrate 30 and on the opposite side of interposer 2. RDLs 60 are formed between, and electrically coupling, solder bumps 42 and TSVs 40. Although only one layer of RDLs 60 is shown, more than one layer of RDLs 60 may be formed. With the formation of RDLs 60, bumps 42 do not have to be vertically aligned to TSVs 40. Instead, bumps 42 and TSVs 40 can be fully or partially misaligned, and electrically coupled through RDLs 60. Bumps 42 may thus be formed substantially uniformly, and the space vertically overlapping die 50 may also be used to form solder bumps 42. In FIGS. 7 and 8, portions of bumps 42 (marked as bumps 42A) and portions of RDLs 60 (marked as RDLs 60A) vertically overlap opening 54, and possibly vertically overlap die 50.

[0026] In the embodiments, the low-cost glass substrates are used to replace the expensive organic substrates, and hence the manufacturing cost is reduced. Further, the photo-sensitive glass that may be integrated in glass substrates can be used as hard masks, and hence the manufacturing process is simpler and easier to control. The loss of high-frequency signals in glass substrates is also low, and hence the electrical characteristics of the package structures are also improved.

[0027] Although the embodiments and their advantages have been described in detail, it should be understood that various changes, substitutions and alterations can be made herein without departing from the spirit and scope of the embodiments as defined by the appended claims. Moreover, the scope of the present application is not intended to be limited to the particular embodiments of the process, machine, manufacture, and composition of matter, means, methods and steps described in the specification. As one of ordinary skill in the art will readily appreciate from the disclosure, processes, machines, manufacture, compositions of matter, means, methods, or steps, presently existing or later to

be developed, that perform substantially the same function or achieve substantially the same result as the corresponding embodiments described herein may be utilized according to the disclosure. Accordingly, the appended claims are intended to include within their scope such processes, machines, manufacture, compositions of matter, means, methods, or steps. In addition, each claim constitutes a separate embodiment, and the combination of various claims and embodiments are within the scope of the disclosure.

What is claimed is:

1. A device comprising:
  - an interposer comprising:
    - a substrate; and
    - a first through-substrate via (TSV) penetrating through the substrate; and
  - a glass substrate bonded to the interposer, wherein the glass substrate comprises a second TSV therein and electrically coupled to the first TSV.
2. The device of claim 1 further comprising:
  - a die bonded to the interposer, wherein the die and the glass substrate are on opposite sides of the interposer; and
  - a solder bump electrically coupled to the second TSV, wherein the solder bump and the interposer are on opposite sides of the glass substrate.
3. The device of claim 2 further comprising a printed circuit board (PCB) bonded to the solder bump.
4. The device of claim 1, wherein the glass substrate comprises a photo-sensitive glass layer, and a non-photo-sensitive glass layer bonded to the photo-sensitive glass layer.
5. The device of claim 4, wherein the non-photo-sensitive glass layer is between the photo-sensitive glass layer and the interposer.
6. The device of claim 1, wherein the interposer comprises a silicon substrate, and wherein no active device is formed in the interposer.
7. The device of claim 1 further comprising:
  - a silicon nitride layer between the interposer and the glass substrate, wherein the silicon nitride layer contacts the substrate in the interposer; and
  - an oxide layer between the silicon nitride layer and the glass substrate.
8. The device of claim 1 further comprising a redistribution line between the interposer and the glass substrate, wherein the redistribution line electrically couples the first TSV to the second TSV.
9. The device of claim 1, wherein the glass substrate comprises an opening, and wherein the device further comprises a die in the opening and bonded to the interposer.
10. The device of claim 9, wherein the opening penetrates through at least a portion of the glass substrate.
11. The device of claim 9, wherein the opening extends from a surface of the glass substrate facing the interposer into the glass substrate, and wherein the opening stops at an intermediate level in the glass substrate.
12. A device comprising:
  - an interposer comprising:
    - a silicon substrate; and
    - a first plurality of through-substrate vias (TSVs) penetrating through the silicon substrate;
  - a glass substrate bonded to the interposer, wherein the glass substrate comprises a second plurality of TSVs therein,

with the first plurality of TSVs being electrically coupled to the second plurality of TSVs;  
 an etch stop layer between the interposer and the glass substrate; and  
 an oxide layer between the etch stop layer and the glass substrate, wherein the second plurality of TSVs penetrates through the oxide layer.

13. The device of claim 12, wherein the etch stop layer comprises silicon nitride.

14. The device of claim 12 further comprising:  
 an opening extending from a surface of the glass substrate into at least an intermediate level of the glass substrate; and  
 a die in the opening and bonded to the interposer.

15. A method of forming a device, the method comprising:  
 providing an interposer comprising:  
 a substrate; and  
 a first through-substrate via (TSV) penetrating through the substrate;

forming a first oxide layer on a surface of the interposer;  
 bonding a glass substrate to the interposer through a fusion bonding, with the first oxide layer being between the interposer and the glass substrate; and  
 forming a second TSV in the glass substrate and electrically coupled to the first TSV.

16. The method of claim 15 further comprising forming a second oxide layer on the glass substrate before the step of bonding, wherein the second oxide layer is bonded to and contacts the first oxide layer after the step of bonding.

17. The method of claim 15, wherein the glass substrate comprises a glass layer comprising an oxide, and wherein the glass layer is directly bonded to the first oxide layer.

18. The method of claim 15, wherein the glass substrate comprises a photo-sensitive glass layer and a non-photo-sensitive glass layer, and wherein the step of forming the second TSV comprises:

exposing the photo-sensitive glass layer using a lithography mask, with first portions of the photo-sensitive glass layer being exposed to light, and second portions of the photo-sensitive glass layer not exposed to the light;

etching the first portions of the photo-sensitive glass layer without etching the second portions of the photo-sensitive glass layer;

using the photo-sensitive glass layer as a hard mask to etch the non-photo-sensitive glass layer; and

filling an opening in the photo-sensitive glass layer and the non-photo-sensitive glass layer with a metallic material to form the second TSV.

19. The method of claim 15 further comprising:  
 before the step of bonding the glass substrate to the interposer, forming an opening extending from a surface of the glass substrate to at least an intermediate level of the glass substrate; and

bonding a die to the interposer, wherein after the step of bonding the glass substrate to the interposer, the die is located in the opening.

20. The method of claim 19, wherein the opening stops at the intermediate level of the glass substrate.

\* \* \* \* \*