



US007241641B2

(12) **United States Patent**
Savastiouk et al.

(10) **Patent No.:** US 7,241,641 B2
(45) **Date of Patent:** Jul. 10, 2007

(54) **ATTACHMENT OF INTEGRATED CIRCUIT STRUCTURES AND OTHER SUBSTRATES TO SUBSTRATES WITH VIAS**

6,163,456 A 12/2000 Suzuki et al.
6,165,885 A 12/2000 Gaynes et al.
6,175,158 B1 1/2001 Degani et al.
6,190,940 B1 2/2001 DeFelice et al.

(75) Inventors: **Sergey Savastiouk**, San Jose, CA (US);
Sam Kao, San Mateo, CA (US)

(Continued)

(73) Assignee: **Tru-Si Technologies, Inc.**, Sunnyvale, CA (US)

FOREIGN PATENT DOCUMENTS

DE 195 31 158 A1 2/1997

(Continued)

(*) Notice: Subject to any disclaimer, the term of this patent is extended or adjusted under 35 U.S.C. 154(b) by 0 days.

OTHER PUBLICATIONS

Ekstrom; Bjorn "Thin Film Silicon Substrates For Lead Frame Packages" *Advancing Microelectronics*—May/Jun. 2003, pp. 6-7.

(Continued)

(21) Appl. No.: **11/253,492**

(22) Filed: **Oct. 19, 2005**

(65) **Prior Publication Data**

US 2006/0040423 A1 Feb. 23, 2006

Primary Examiner—Walter Lindsay, Jr.
Assistant Examiner—Kyoung Lee

(74) *Attorney, Agent, or Firm*—Michael Shenker; MacPherson Kwok Chen & Heid LLP

Related U.S. Application Data

(60) Division of application No. 10/798,540, filed on Mar. 10, 2004, which is a continuation-in-part of application No. 10/739,788, filed on Dec. 17, 2003, now Pat. No. 7,049,170.

(57) **ABSTRACT**

Vias (210, 210B) are formed in a surface of a substrate. At least portions of contact pads (139, 350) are located in the vias. Contact pads (150, 340) of an integrated circuit structure are inserted into the vias and attached to the contact pads (139, 350) of the substrate. The vias provide a strong, reliable mechanical and electrical connection. A via may expose not only a contact pad (350) in the substrate but also a surrounding region. Solder (930) wets the contact pad better than the surrounding region, resulting in a stronger solder joint and better electrical conductivity. Alternatively, the contact may include multiple conductive layers (910.1, 910.2), with the top layer (910.2) being more solder wettable than the bottom layer (910.1) and the top layer covering only a portion of the bottom layer.

(51) **Int. Cl.**

H01L 21/44 (2006.01)

(52) **U.S. Cl.** 438/106; 438/106; 438/107; 438/108; 257/E21.511

(58) **Field of Classification Search** None
See application file for complete search history.

(56) **References Cited**

U.S. PATENT DOCUMENTS

5,391,514 A 2/1995 Gall et al.
5,611,140 A * 3/1997 Kulesza et al. 29/832

27 Claims, 13 Drawing Sheets

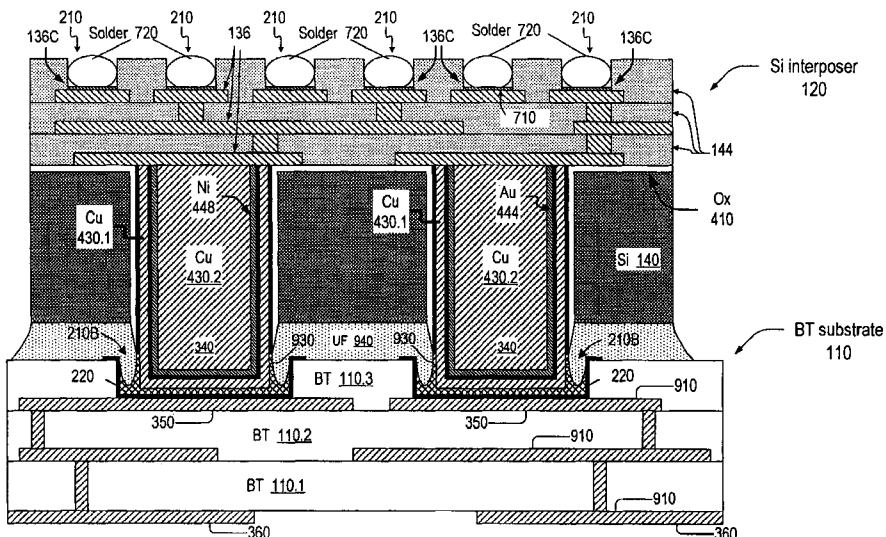

U.S. PATENT DOCUMENTS

6,322,903	B1 *	11/2001	Siniaguine et al.	428/617
6,498,074	B2	12/2002	Siniaguine et al.	
6,498,381	B2	12/2002	Halahan et al.	
6,661,088	B1	12/2003	Yoda et al.	
6,903,443	B2	6/2005	Farnworth et al.	
2001/0019178	A1 *	9/2001	Brofman et al.	257/780
2002/0036340	A1	3/2002	Matsuo et al.	
2002/0048916	A1	4/2002	Yangida	
2002/0074637	A1	6/2002	McFarland	
2002/0175421	A1	11/2002	Kimura	
2003/0047798	A1	3/2003	Halahan	
2003/0080437	A1	5/2003	Gonzalez et al.	
2003/0116859	A1	6/2003	Hashimoto	
2003/0199123	A1	10/2003	Siniaguine	
2004/0087057	A1 *	5/2004	Wang et al.	438/106

FOREIGN PATENT DOCUMENTS

EP	0 193 128	9/1986
JP	08-236579	9/1996
WO	WO 01/45476	6/2001

OTHER PUBLICATIONS

200mm Wafer Fab Strand Interconnect, Partner for High Performance Electronics.
 Chapter 7: Wedge and Double Cantilever Beam Tests on a High Temperature Melt Processable Polyimide Adhesive, TPER-BPDA-PA, pp. 221-242.
 Design Notes: Understanding Ball Grid Array Packages Electronics by Design, www.electronicsbydesign.com.au, issue 1997.10, pp. 1-4.
 Flip Chip Bonding in Practice Issue No. 7, Sep. 2001, The Micro Circuit Engineering Newsletter.
 Gektin, Vadim; Bar-Cohen, Avram; Witzman, Sorin "Coffin-Mason Based Fatigue Analysis of Underfilled DCAs," 1998 IEEE Transactions on Components, Packaging, and Manufacturing Technology, Part A, vol. 21, No. 4, Dec. 1998, pp. 577-584.
 Gilleo, Ken "Substrates for Flip Chips" "Flip Chips Technology" in Area Array Packaging Handbook—Manufacturing and Assembly; K Gillio, Editor; The McGraw-Hill Companies, Inc., New York, NY.
 Guenin, Bruce M. "The Many Flavors of Ball Grid Array Packages" Electronics Cooling, Feb. 2002, pp. 1-7.
 HPMX-5001: Demonstration Circuit Board: Application Brief 102 Hewlett Packard, pp. 1-10.
 Introduction to Printed Wiring Boards Netpack Education Pool, p. 1-18.
 Jasper, Jorg "Gold or Solder Chip Bumping, the choice is application dependent" Chip Interconnection, EM Marin, pp. 1-4.
 Jordan, Jerry "Gold Stud Bump In Flip-Chip Applicatins," 2002 Palomar Technologies, Inc.
 Lu, H. and Bailey, C. "Predicting Optimal Process Conditions for Flip-Chip Assembly Using Copper Column Bumped Dies" School of Computing and Mathematical Sciences, 2002 IEEE, 2002 Electronics Packaging Technology Conference, pp. 338-343.

Maiwald, Werner "soldering SMD's Without Solder Paste" <http://www.midwestpcb.com/sales/KeHoe/maiwald.htm>.
 Moon, K.W.; Boettinger, W.J.; Kattner, U.R.; Biancaniello, F.S.; Handwerker, C.A. "The Ternary Eutectic of Sn-Ag-Cu Colder Alloys" Metallurgy Division, Materials Science and Engineering Laboratory NIST Gaithersburg, MD 20899 USA.
 Painaik, Mandar; and Hurley, Jim "Process Recommendations for Assembly of Flip Chips Using No-Flow Underfill" Semiconductor Products, Technical Bulletin, www.cooksonsemi.com.
 Pang, John H.L.; Chong, D.Y.R.; Low T.H. "Thermal Cycling Analysis of Flip-Chip Solder Joint Reliability" IEEE Transactions on Components and Packaging Technologies, vol. 24, No. 4, Dec. 2001, pp. 705-712.
 Perfecto, Eric; Lee, Kang-Wook; Hamel, Harvey; Wassick, Thomas; Cline, Christopher; Oonk, Matthew; Feger, Claudius; McHerron, Dale, "Evaluation of Cu Capping Alternatives for Polyimide-Cu MCM-D" IEEE, 2001 Electronic Components and Technology Conference.
 Productions Qualification Report: Select Qual B: Strand Substrate on MCM MQFP Qual Amkor Technology, Date Released: Jun. 14, 2002.
 Solving Soldering Hierarchy Problems by Metallurgy and Design IBM Technical Disclosure Bulletin, IBM Corp. New York, US, vol. 33, No. 8, Jan. 1991, pp. 298-299, XP000106967, ISSN: 0018-8689.
 Sperling, Ed; Electronics News, Sep. 17, 2003.
 Staychip; 2078E No-Flow Fluxing Underfill; For Solding Sn/Pb eutectic solder bumps to common pad metallizations Preliminary Technical Bulletin Semiconductor Products, Technical Bulletin; Cookson Electronics.
 Strand is Closing the Enterprise Strand Interconnect AB, Viggengatan5, SE-602 09 Norrkoping Sweden, www.strandinter.se.
 Technical Data Sheet: No-Clean Pin-Probe Testable Solder Paste: NC253 www.aimsolder.com.
 Tran, S.K.; Questad, D.L.; Sammakia, B.G. "Adhesion Issues in Flip-Chip on Organic Modules," 1998 InterSociety Conference on Thermal Phenomena, pp. 263-268.
 U.S. Appl. No. 10/739,707, entitled "Packaging Substrates For Integrated Circuits and Soldering Methods," filed on Dec. 17, 2003.
 U.S. Appl. No. 10/798,540, entitled "Attachment of Integrated Circuit Structures and Other Substrates to Substrates with Vias," filed on Mar. 10, 2004.
 Wang, C.H.; Holmes, A.S.; Gao, S. "Laser-Assisted Bump Transfer for Flip Chip Assembly," 2000 IEEE Int'l Symp on Electronic Materials & Packaging, pp. 86-90.
 Wang, Tie; Tung, Francisca; Foo, Louis; and Dutta, Vivek "Studies on A Novel Flip-Chip Interconnect Structure—Pillar Bump" Advanpack Solutions Pte Ltd, 2001 IEEE, 2001 Electronic Components and Technology Conference.
 www.flipchips.com/tutorial27.html "Flipchips: Tutorial 27, Shaping Gold Stud Bumps" pp. 1-8.
 Zama, Satoru; Baldwin, Daniel F; Hikami, Toshiya; Murata, Hideaki "Flip Chip Interconnect Systems Using Wire Stud Bumps and Lead Free Solder," 2000 IEEE Electronic Components and Technology Conference, pp. 1111-1117.

* cited by examiner

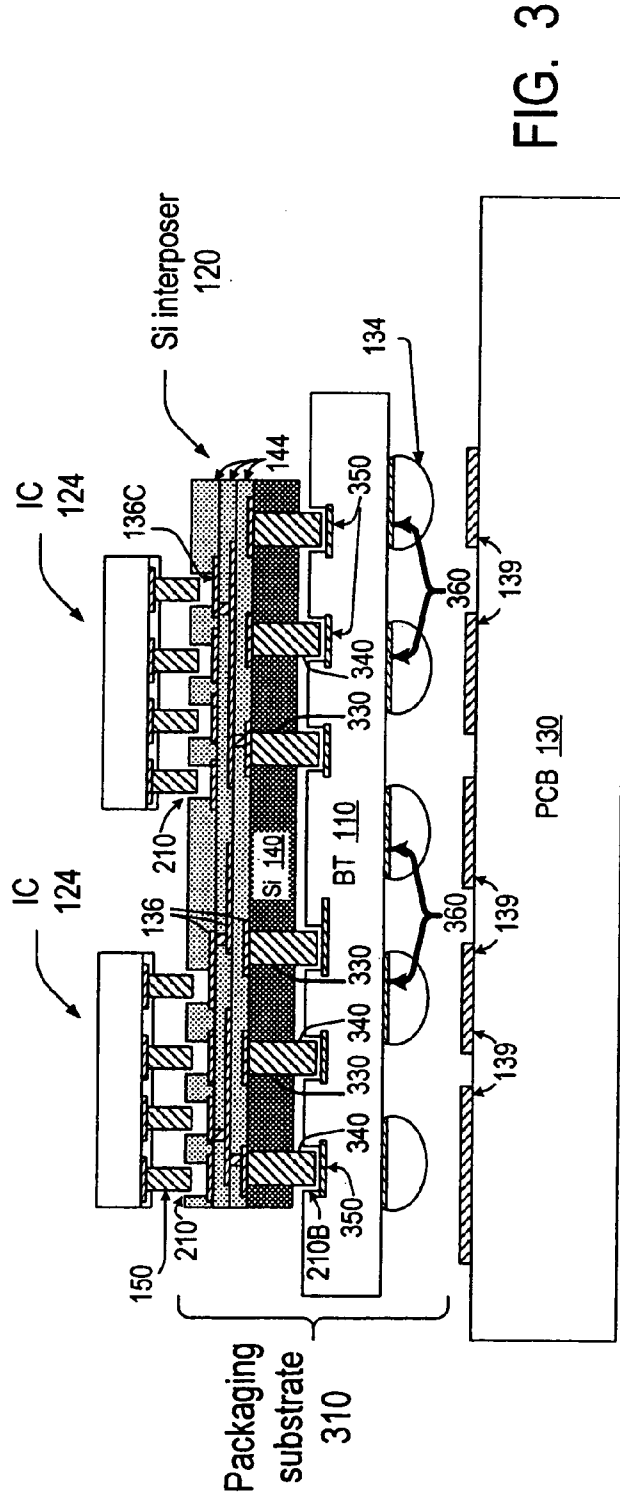
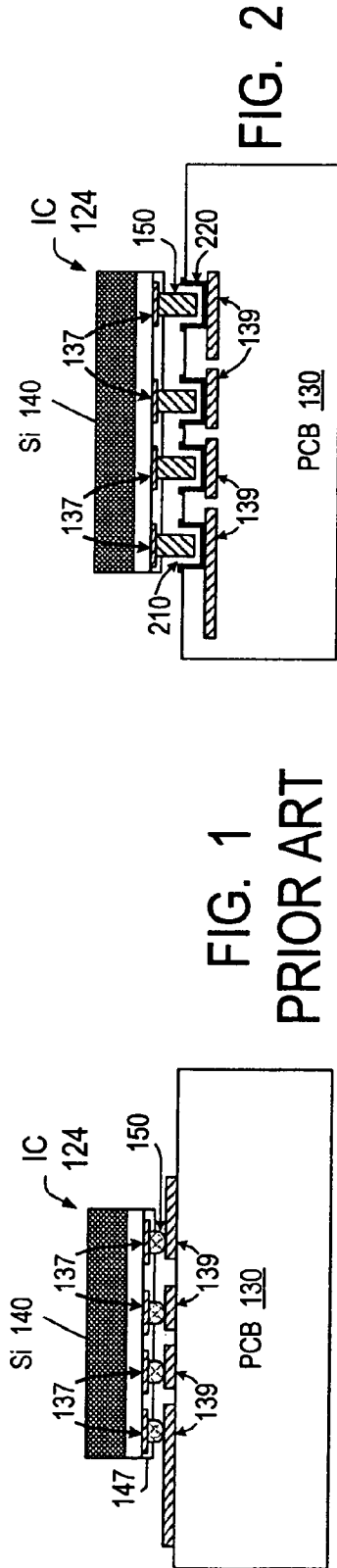

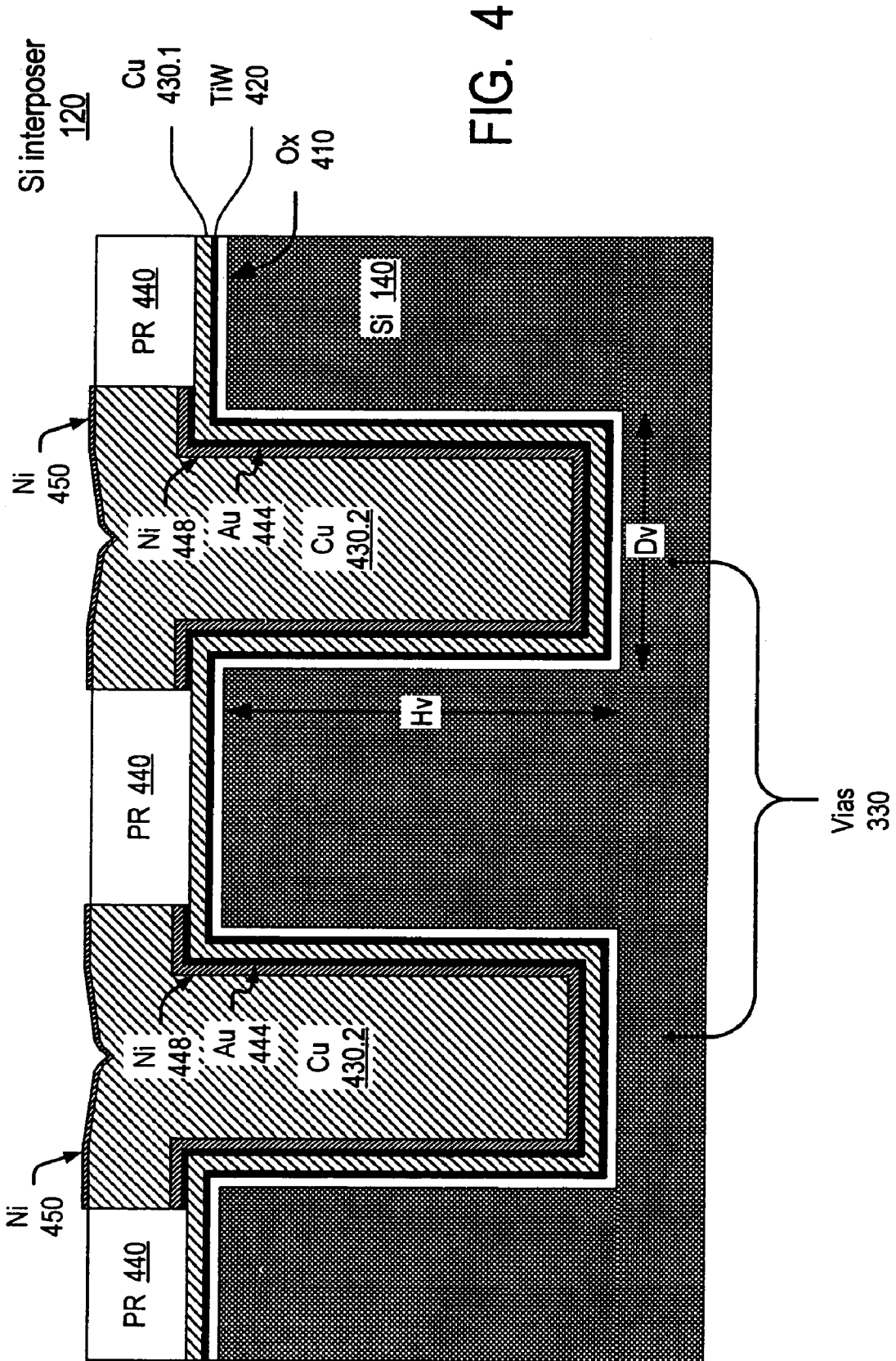
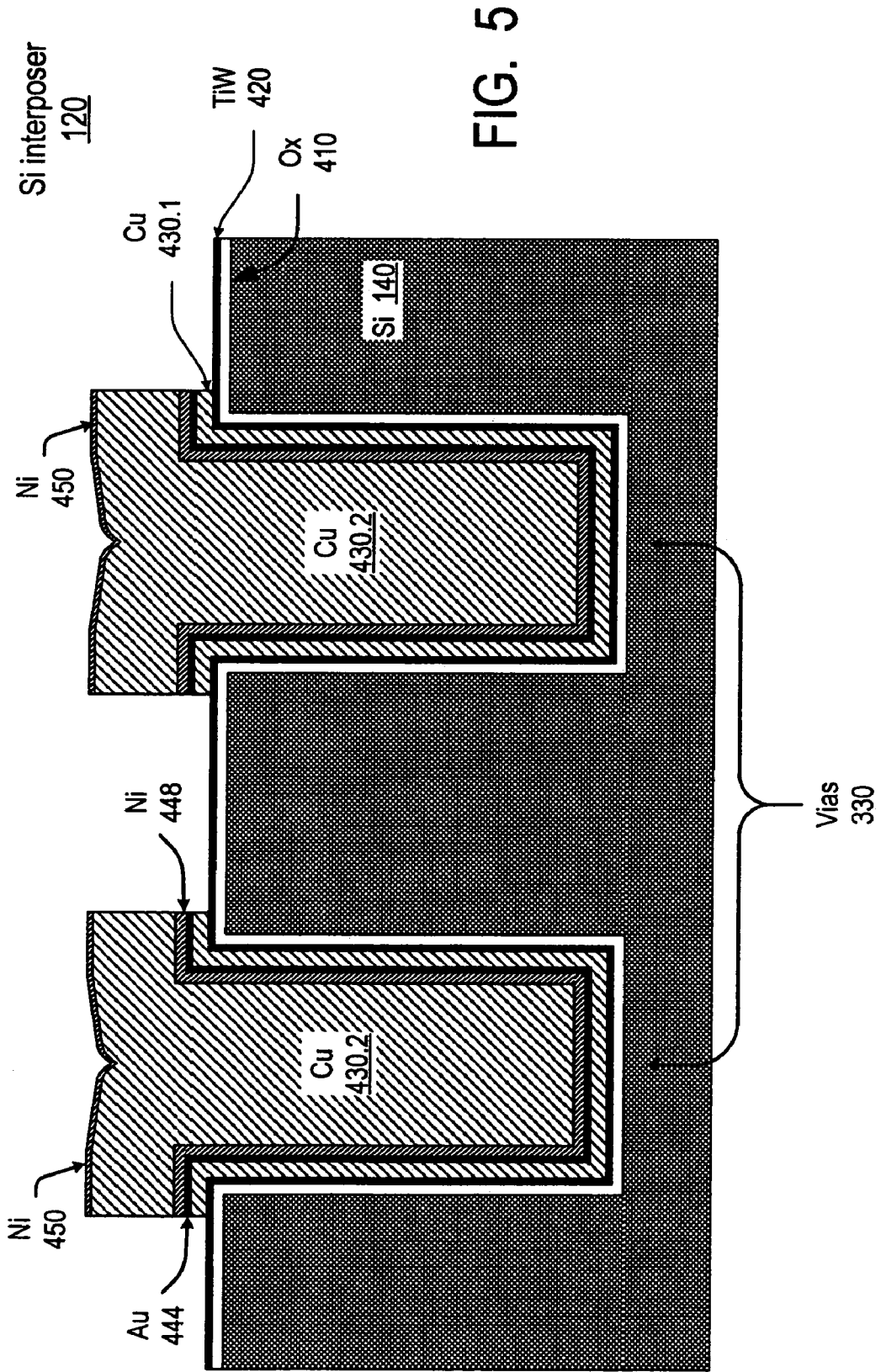

FIG. 4



Si interposer
120

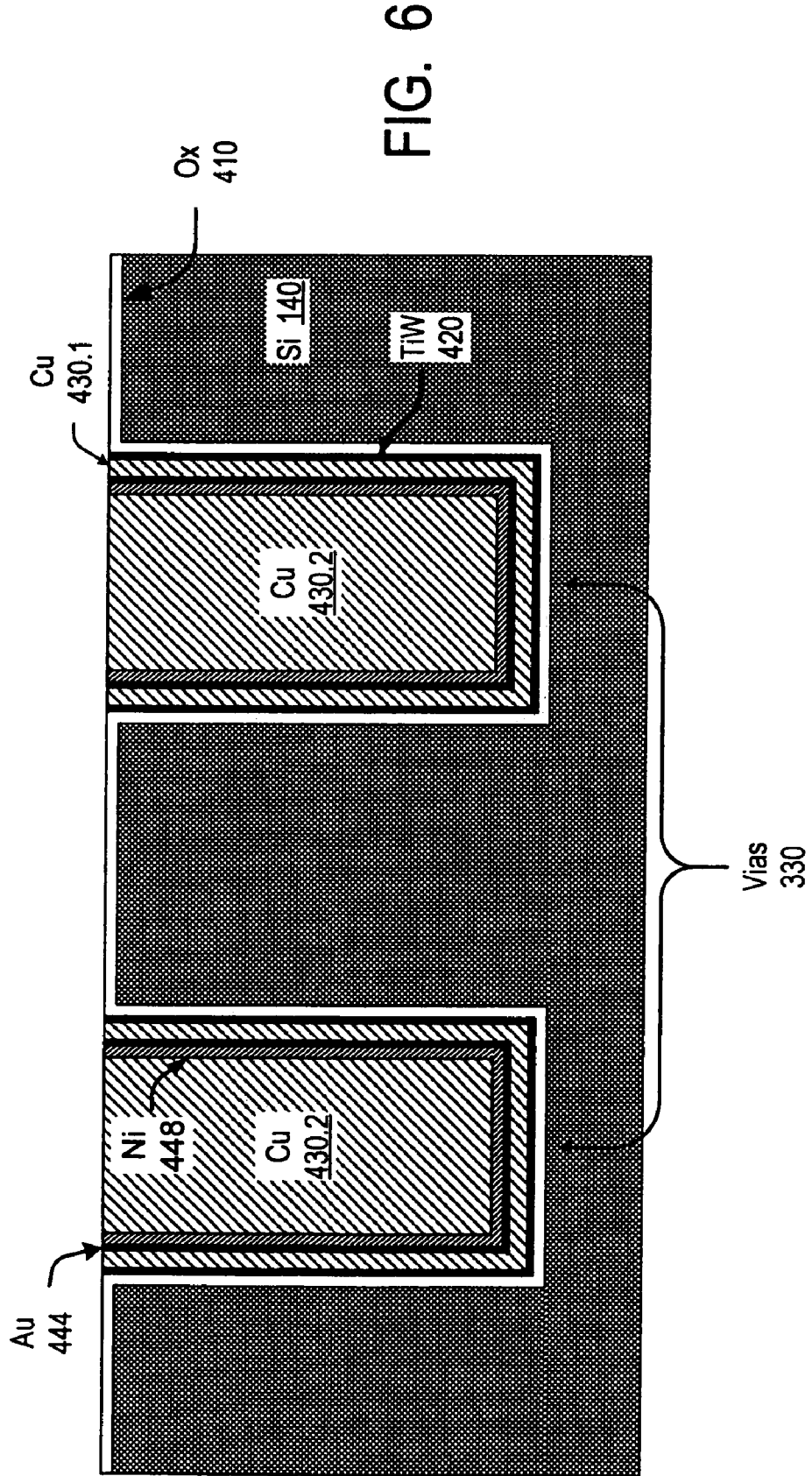

FIG. 6

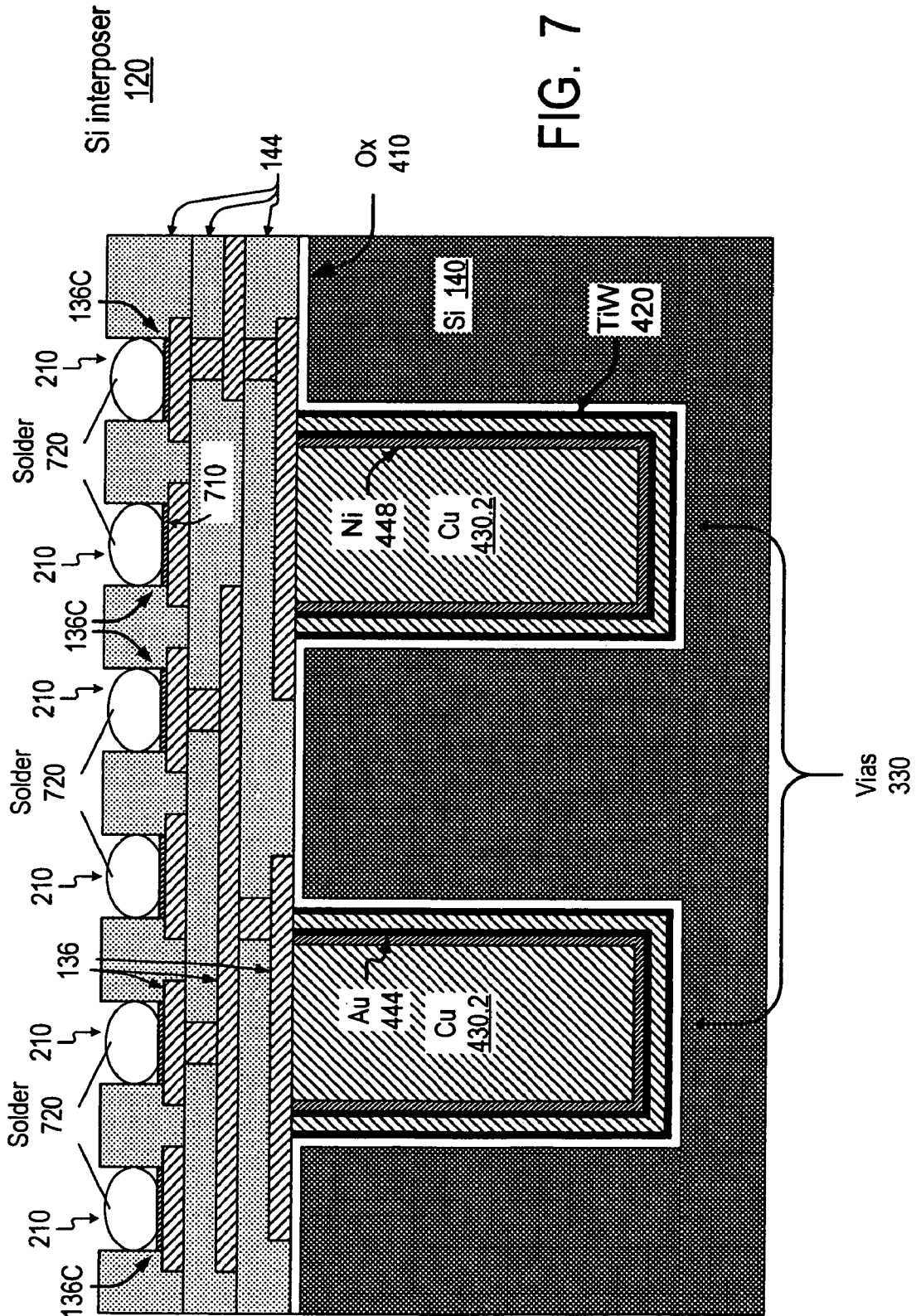

FIG. 7

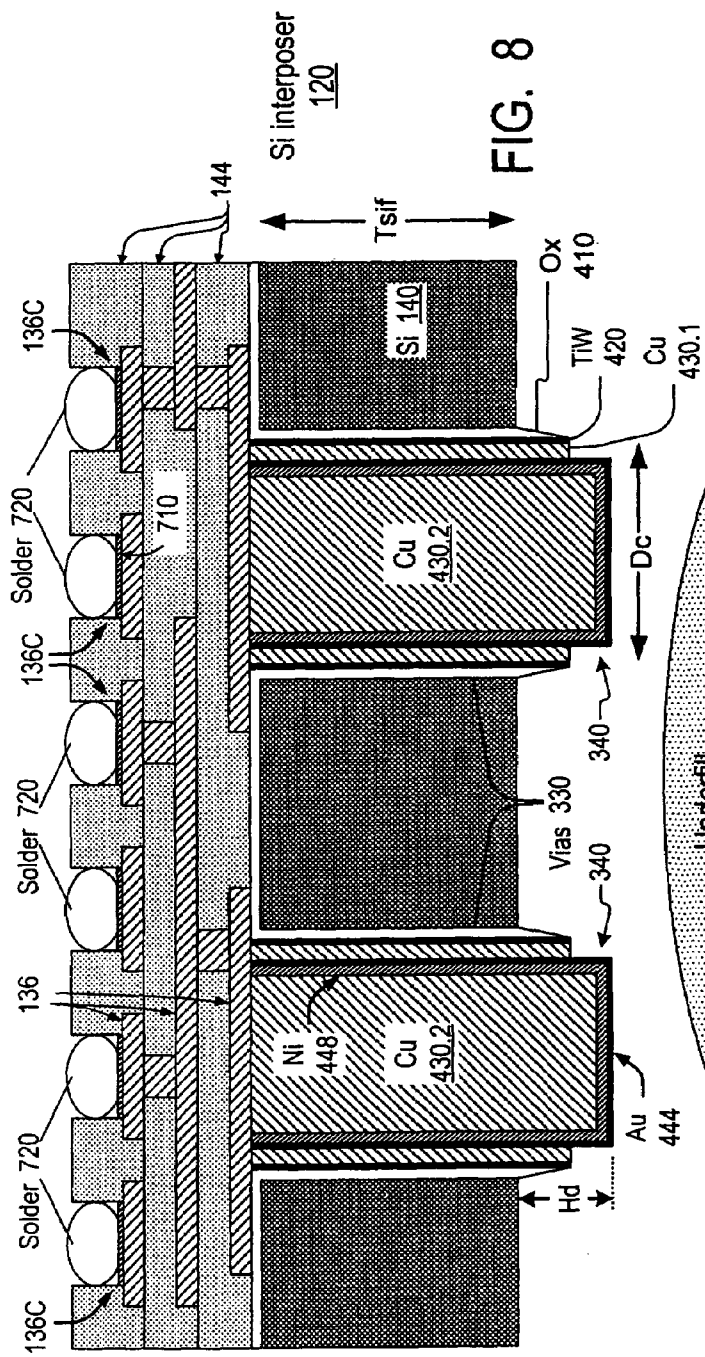

FIG. 8

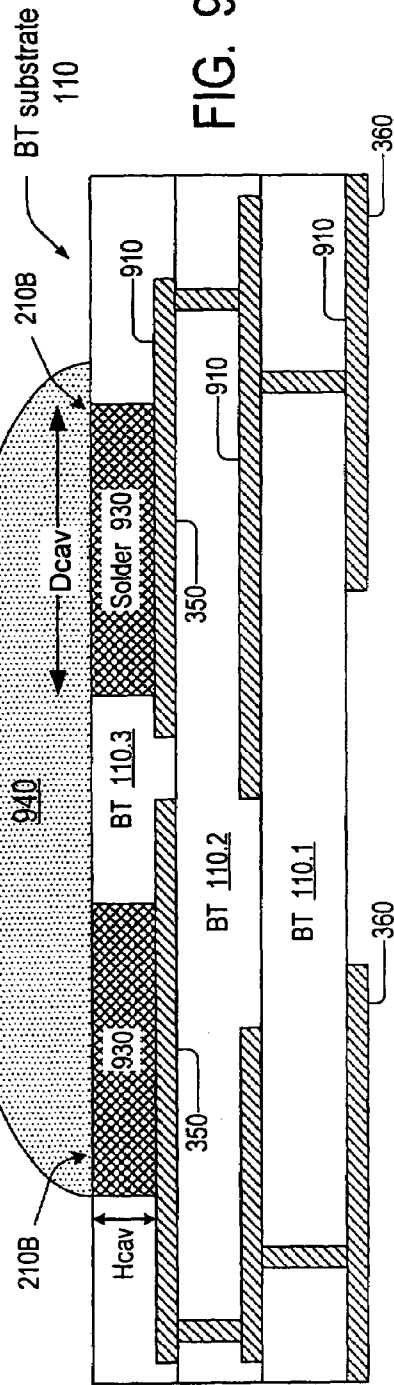

FIG. 9

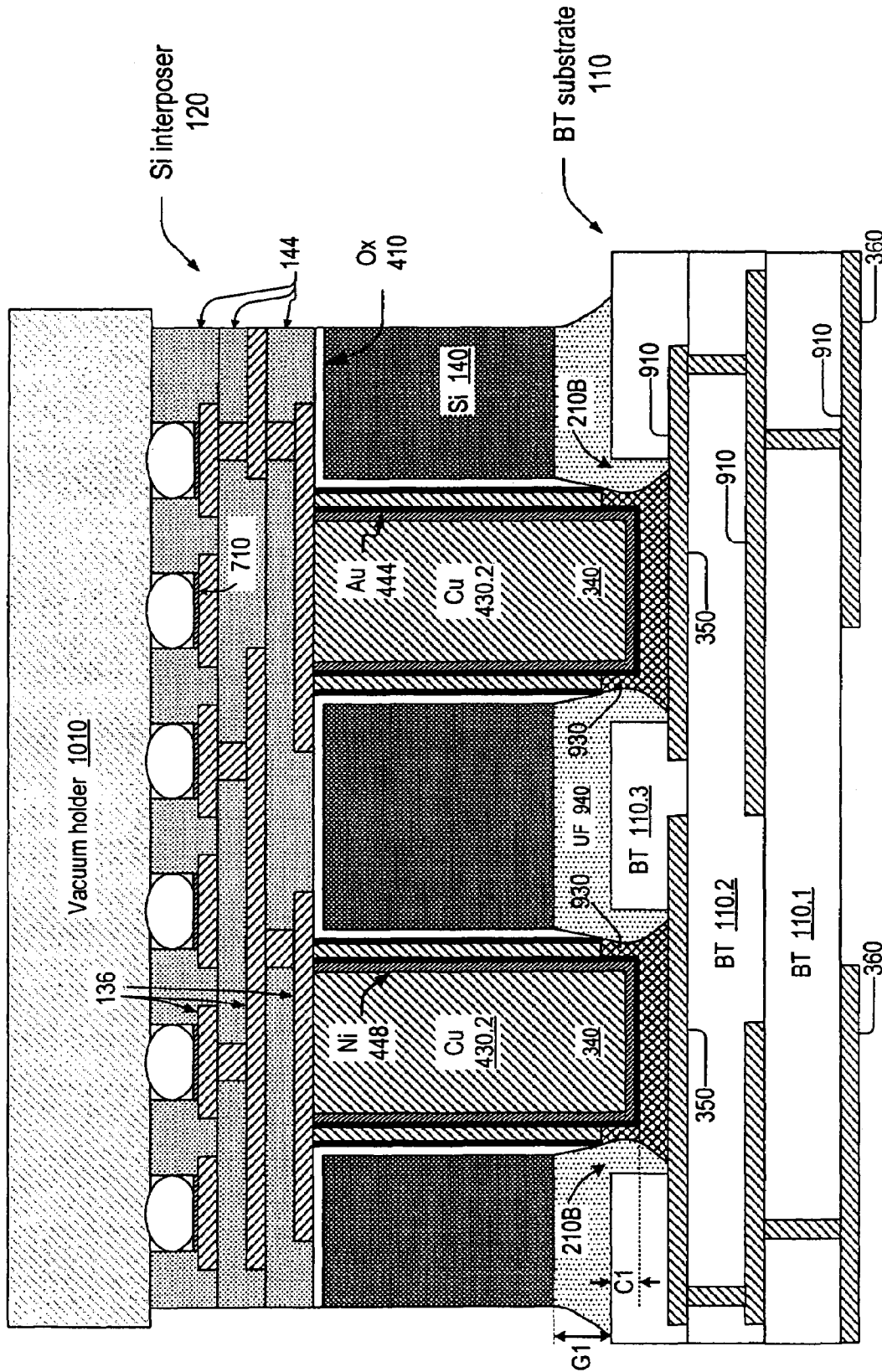

FIG. 10

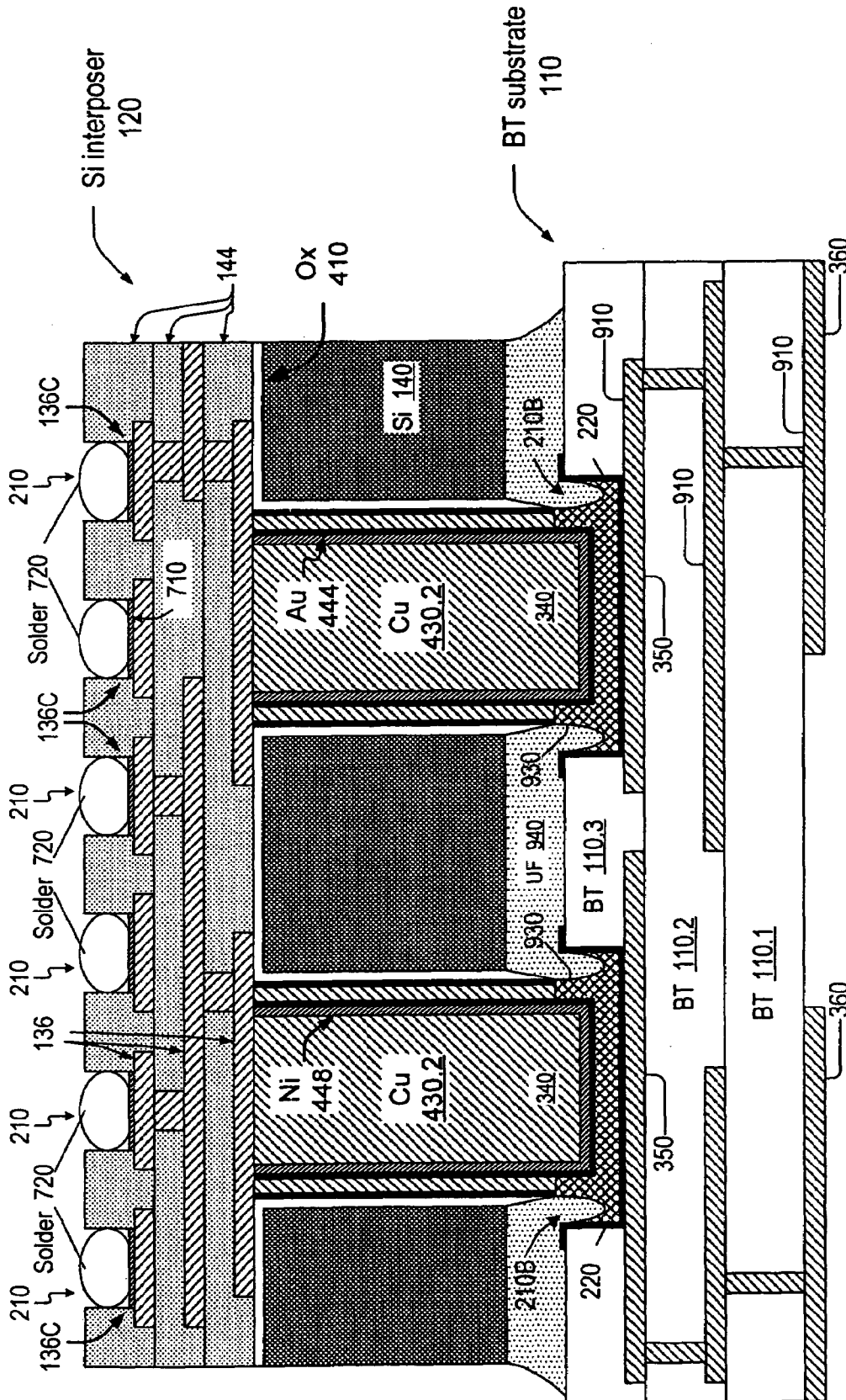

FIG. 11

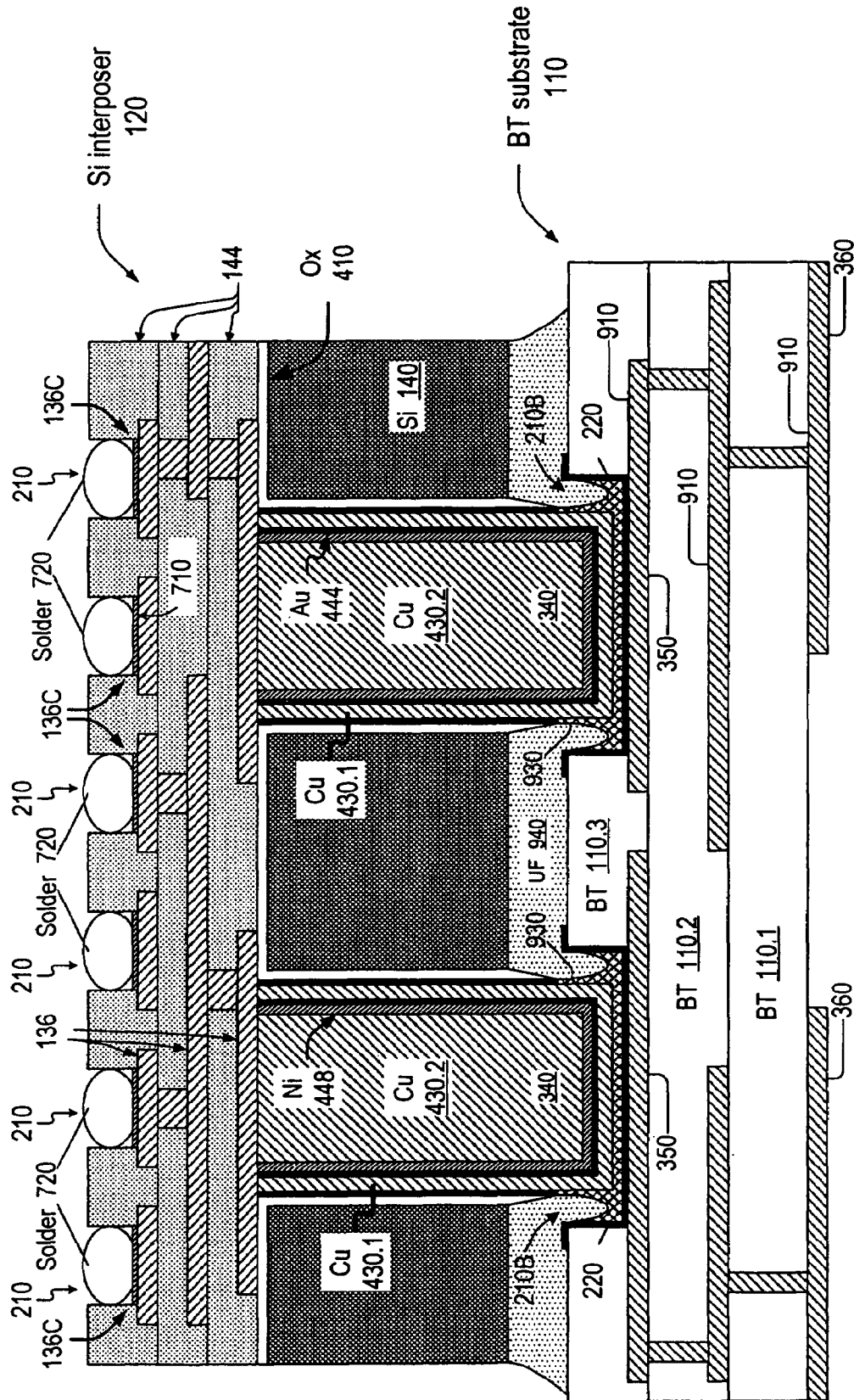

FIG. 12

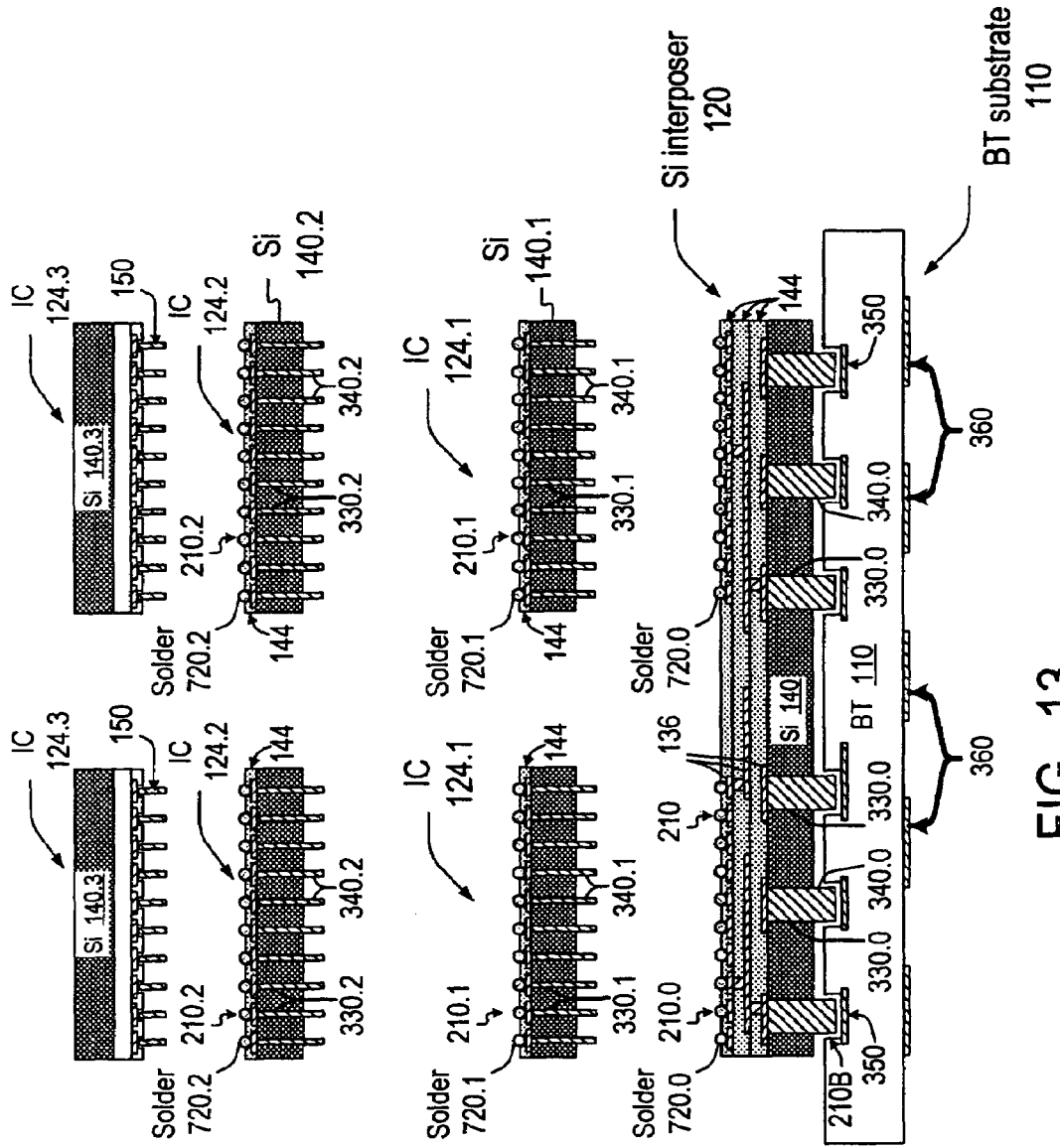

FIG. 13

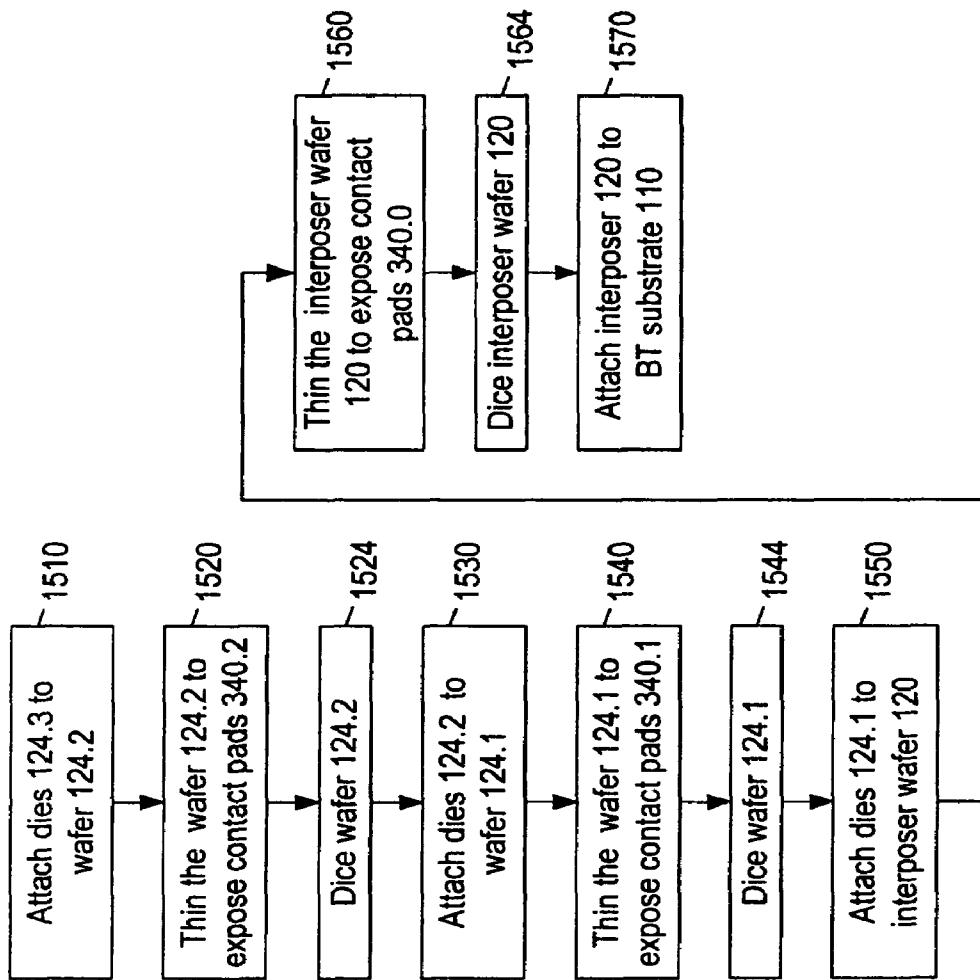

FIG. 15

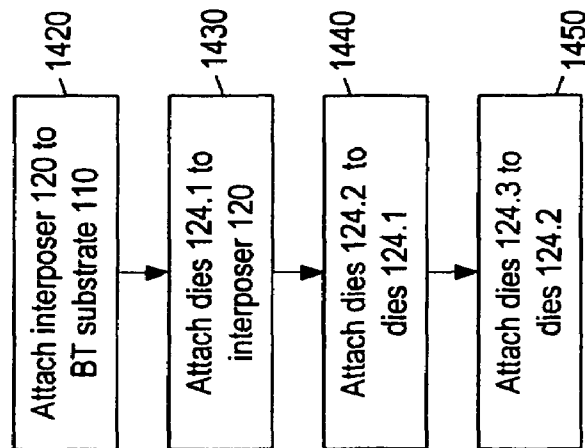

FIG. 14

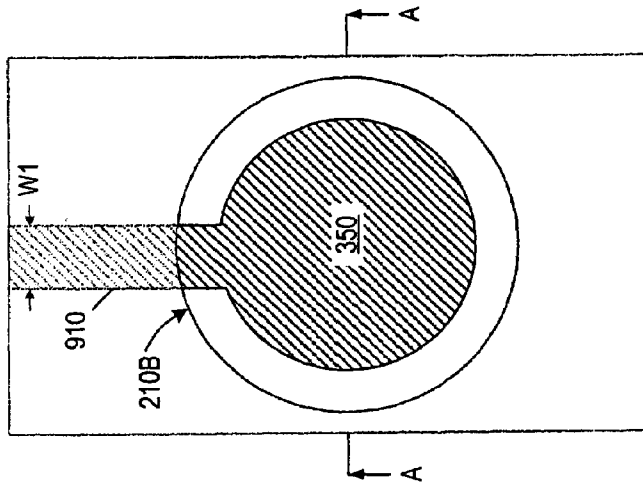

FIG. 16B

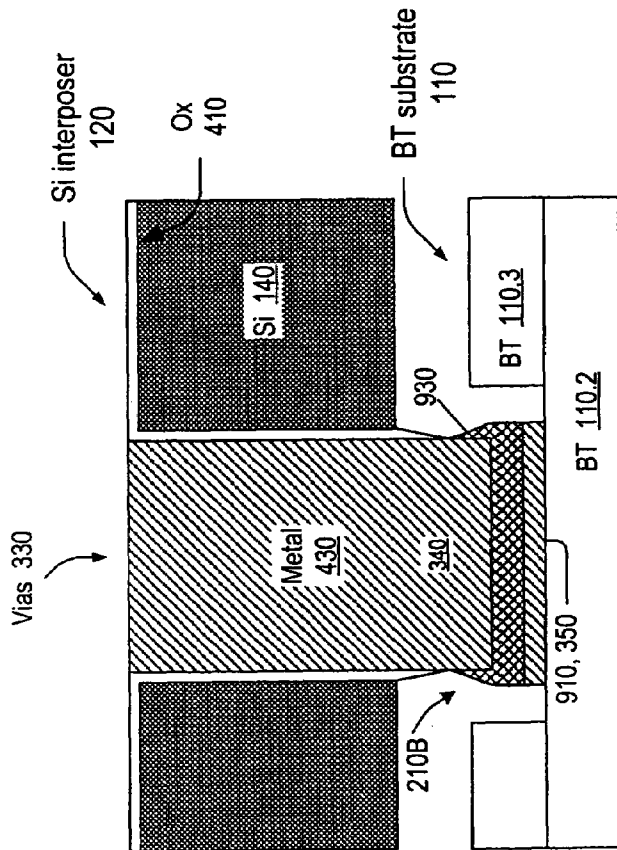

FIG. 16A

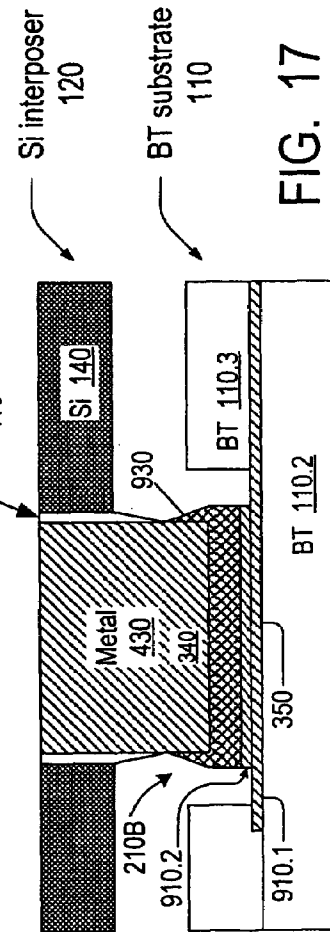

FIG. 17

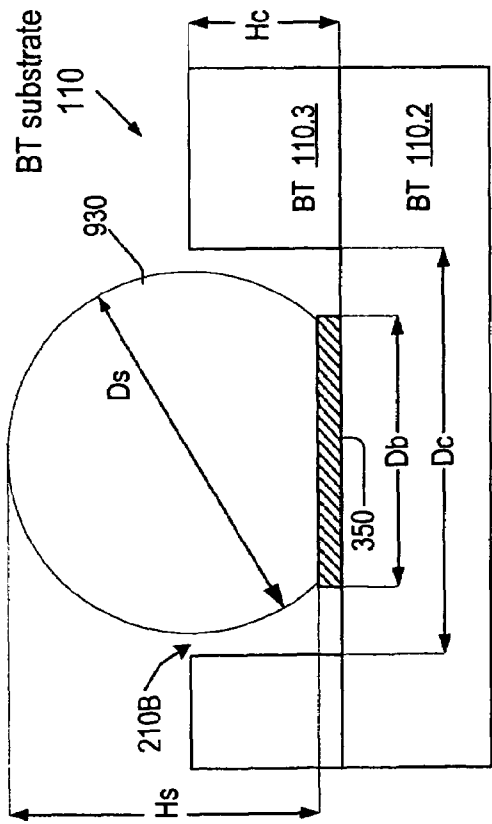

FIG. 18

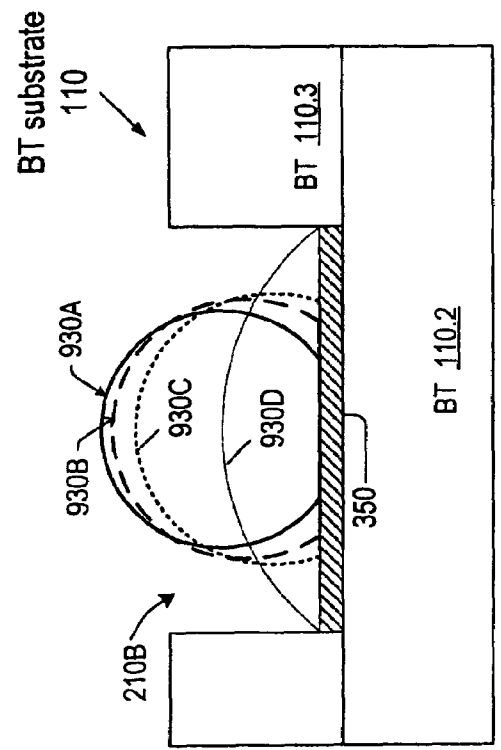

FIG. 19

1

ATTACHMENT OF INTEGRATED CIRCUIT STRUCTURES AND OTHER SUBSTRATES TO SUBSTRATES WITH VIAS

CROSS REFERENCE TO RELATED APPLICATIONS

The present application is a division of U.S. patent application Ser. No. 10/798,540 filed on Mar. 10, 2004 by S. Savastiouk et al., entitled "ATTACHMENT OF INTEGRATED CIRCUIT STRUCTURES AND OTHER SUBSTRATES TO SUBSTRATES WITH VIAS", incorporated herein by reference, which is a continuation-in-part of U.S. patent application Ser. No. 10/739,788 filed on Dec. 17, 2003 now U.S. Pat. No. 7,049,170 by S. Savastiouk et al., entitled "INTEGRATED CIRCUITS AND PACKAGING SUBSTRATES WITH CAVITIES, AND ATTACHMENT METHODS INCLUDING INSERTION OF PROTRUDING CONTACT PADS INTO CAVITIES", incorporated herein by reference.

BACKGROUND OF THE INVENTION

The present invention relates to attachment of integrated circuits to other substrates.

Integrated circuit dies ("chips") can be attached to a lead frame and then packaged in a ceramic or plastic carrier. The leads of the lead frame can then be soldered to a printed circuit board (PCB). Alternatively, the chip can be soldered directly to the PCB ("flip chip" packaging). The flip chip packaging reduces the package size and shortens the electrical connections between the die and the PCB. FIG. 1 illustrates a chip 124 flip-chip attached to a PCB 130. The chip is attached face down, with its contact pads 137 connected to contact pads 139 of the PCB.

In the manufacturing process, contact pad metal layer 137 (the layer that provides the contact pads) is deposited and patterned over the chip's silicon substrate 140. A passivation dielectric layer 147 is formed on layer 137. Openings are formed in dielectric 147 to expose the contact pads 137. As a result, contact pads 137 are recessed into the chip's surface. To connect the contact pads 137 to the PCB, protruding metal bumps 150 are formed on the contact pads. Bumps 150 are bonded to PCB contact pads 139 with solder, an adhesive, or by thermal or thermosonic compression.

Bumps 150 can themselves be made of solder. The chip is placed on the PCB with bumps 150 on pads 139, and solder 150 is reflowed to form solder joints. This attachment is mechanically strong and reliable in the presence of thermal stresses, but the solder bumps are difficult to scale down as contact pads 137 become smaller and the pitch between the pads 137 is reduced. As the solder bump sizes decrease to accommodate the smaller contact pads and pitches, the solder joints become mechanically and thermally weaker. Also, the solder ball (solder bump) size defines the standoff distance between the chip 124 and PCB 130. If the standoff is too small, there will be increased fatigue stresses on the solder joints during thermal cycling. In addition, there is a greater possibility of undesirable residues remaining between the chip 124 and the PCB and causing some degradation.

Bumps 150 can also be made without solder, e.g. from copper (Cu) or gold (Au), to obtain better scalability. See S. Zama et al., "Flip Chip Interconnect Systems Using Wire Stud Bumps and Lead Free Solder", 2000 *Electronic Components and Technology Conference*, pages 1111-1117 (available from IEEE); C. H. Wang et al., "Laser-Assisted

2

Bump Transfer for Flip Chip Assembly", 2000 *International Symposium on Electronic Materials & Packaging*, pages 86-90 (available from IEEE), both incorporated herein by reference. A combination of solder and copper has also been used. More particularly, a "copper pillar" can be plated on contact pads 137, then solder is plated on the copper pillar. See H. Lu et al., "Predicting Optimal Process Conditions for Flip-Chip Assembly Using Copper Column Bumped Dies", 2002 *Electronics Packaging Technology Conference*, pages 338-343 (available from IEEE); Tie Wang et al., "Studies on a Novel Flip-Chip Interconnect Structure—Pillar Bump", 2001 *Electronic Components and Technology Conference* (available from IEEE), both incorporated herein by reference.

Improved integrated circuit attachment techniques are desirable.

SUMMARY

This section summarizes some features of the invention. Other features are described in the subsequent sections. The invention is defined by the appended claims which are incorporated into this section by reference.

In some embodiments of the present invention, cavities are formed in the PCB, and the integrated circuit bumps are inserted into the cavities. For example, in FIG. 2, cavities 210 are formed in the top surface of PCB 130. At least a portion of each contact PCB pad 139 is located in the corresponding cavity. Bumps 150 are inserted into the cavities and attached to contact pads 139. Bumps 150 may be solderless bumps, e.g. they may be copper columns, gold wires, or some other kind of bumps, known or to be invented. Bumps 150 may also include solder. Bumps 150 can be attached to PCB contact pads 139 with solder, a conductive or anisotropic adhesive, by thermal or thermosonic compression, or some other technique, known or to be invented. For example, in some embodiments, solder paste or an adhesive (not shown) are deposited in cavities 210, then the die 124 is placed on the PCB with the bumps 150 inserted into the cavities.

In some embodiments, cavities 210 increase the mechanical strength of the structure. The structure becomes stronger against lateral forces (including lateral stresses caused by thermal expansion). Also, the amount of solder or adhesive can be increased by increasing the depth of cavities 210 without increasing the lateral size of the structure. Improved scalability is therefore provided.

In addition, if bumps 150 are attached with solder or a conductive or anisotropic adhesive, the size uniformity requirements for bumps 150 are relaxed. If the bumps are not uniform in size, the shorter bumps will still provide a reliable electrical connection to contacts 139 as long as there is a reliable electrical connection between the bumps and the solder or adhesive in cavities 210.

In FIG. 2, an optional conductive film 220 (e.g. metal) is formed on the bottom and sidewalls of each cavity 210. Film 220 is believed to improve the strength and the electrical conductivity of the bond between bumps 150 and contact pads 139. Film 220 is not necessary however.

Bumps 150 can be thought of as "contact pads", and the invention is applicable to any protruding contact pads and not necessarily the protruding pads formed by bumping a die. For example, protruding contact pads can be formed on a die by removing the die material to expose metal features, as described in U.S. Pat. No. 6,322,903 issued Nov. 27, 2001 to Siniaguine et al. and incorporated herein by reference.

In some embodiments, layer 220 is absent, and a cavity 210 exposes not only the contact pad 139 but also a surrounding dielectric region in substrate 130. The solder (not shown) wets the contact pad 139 better than the surrounding region, so more solder gathers near the bump 150, and the solder reaches up higher along the surface of bump 150. This is believed to provide a stronger solder joint and better electrical conductivity at least in some embodiments. Alternatively, the contact pad 139 or layer 220 may include multiple conductive layers, with the top layer being more solder wettable than the bottom layers and the top layer covering only a portion of the bottom layers. The solder will preferentially wet the more solder wettable layer, gathering closer to bump 150 and reaching up higher.

The invention is not limited to the embodiments discussed in this section. For example, cavities 210 can be replaced by through vias (through holes) that pass through the PCB 130. Contacts 139 can be metal layers on the sidewalls of the through vias. The integrated circuit structure 124 can be a wafer rather than a die. PCB 130 can be replaced with a ball grid array substrate (BGA) or some other packaging substrate, e.g. a silicon interposer. PCB 130 can also be replaced with another integrated circuit structure (a die or a wafer). Other features and advantages of the invention are described below. The invention is defined by the appended claims.

BRIEF DESCRIPTION OF THE DRAWINGS

FIG. 1 shows a vertical cross section of an integrated circuit attached to a PCB according to prior art.

FIGS. 2, 3 show vertical cross sections of integrated circuits attached to substrates according to embodiments of the present invention.

FIGS. 4–8 show vertical cross sections of integrated circuits in the process of fabrication for attachment according to embodiments of the present invention.

FIG. 9 shows a vertical cross section of a BT substrate fabricated according to an embodiment of the present invention.

FIGS. 10–13 show vertical cross sections of integrated circuits attached to substrates according to embodiments of the present invention.

FIGS. 14, 15 are flowcharts of an integrated circuit packaging processes according to embodiments of the present invention.

FIG. 16A shows a vertical cross section of an interposer attached to a substrate according to some embodiments of the present invention.

FIG. 16B is a top view of the structure of FIG. 16A.

FIG. 17 shows a vertical cross section of an interposer attached to a substrate according to some embodiments of the present invention.

FIGS. 18, 19 illustrate possible shapes of solder for the embodiments of FIGS. 16A, 16B, 17.

DESCRIPTION OF SOME EMBODIMENTS

The embodiments described in this section illustrate but do not limit the invention. The invention is not limited to particular materials, process steps, or dimensions. The invention is defined by the appended claims.

FIG. 3 illustrates another integrated circuit packaging structure. Integrated circuit packaging substrate 310 is an intermediate substrate that provides an interconnection between dies 124 and PCB 130. Substrate 310 includes two intermediate integrated circuit packaging substrates 110, 120. Substrate 120 is a silicon interposer attached to BT

substrate 110, and thus is itself a semiconductor integrated circuit. The attachment is made as described above in connection with FIG. 2. More particularly, cavities 210B (also called vias or openings herein) are formed in the top surface of BT substrate 110. Protruding contact pads 340 of interposer 120 are inserted into the cavities.

Dies 124 are attached to interposer 120 as in FIG. 2. More particularly, cavities 210 are formed in the top surface of the interposer, and the dies' bumps 150 are inserted into these cavities. BT substrate 110 is attached to PCB 130 in a conventional manner. More particularly, solder balls 134 are attached to contact pads 360 on the bottom surface of BT substrate 110, and the solder balls are later reflowed to solder the contact pads 360 to PCB contact pads 139. These features are not limiting. For example, in some embodiments, the cavities are used to attach the dies 124 to interposer 120 but the attachment of interposer 120 to BT substrate 110 is performed without cavities. In other embodiments, the cavities are used to attach the interposer 120 to BT substrate 110, but the attachment of dies 124 to interposer 120 is performed without cavities. In other embodiments, the cavities are used to attach one but not both dies 124 to interposer 120. Also, the cavities can be used to attach some but not all of the a single die's contact pads to the interposer, or some but not all of the interposer's contact pads 340 to BT substrate 110.

Silicon interposer 120 includes metal layers 136 formed over silicon substrate 140. Substrate 140 has substantially planar top and bottom surfaces, and is quite thin. In some embodiments, the planarity of substrate 140 is suitable for fine geometry photolithography (finer than possible with BT and FR4 substrates). The thickness of substrate 140 can be 100 μm or less (50 μm to 35 μm thickness values believed to be achievable, and smaller values may be possible). Layers 136 provide interconnect lines and may also provide power and ground planes, resistors, inductors, capacitor plates for decoupling capacitors and other capacitor types, and possibly other elements, known or to be invented. Layers 136 can be separated from each other, and from the substrate, by dielectric layers 144. Layers 136 contact each other and the silicon substrate through openings in the dielectric layers. Layers 136 can also be formed directly on the silicon substrate if desired. Layers 136 provide contact pads 136C at the top surface of the interposer. At least a portion of each contact pad 136C is located in a corresponding cavity 210.

These features are exemplary and not necessary. For example, silicon substrate 140 can be thicker than described above, and its top and bottom surfaces do not have to be planar.

In the embodiment of FIG. 3, silicon substrate 140 includes metalized through-silicon vias 330 that pass between the top and bottom surfaces of substrate 140. Conductive paths are provided from contact pads 136C at the top of the interposer to contact pads 340 at the bottom of the interposer through the vias 330. Contact pads 340 protrude out of vias 330. Contact pads 340 are attached to contact pads 350 at the top surface of BT substrate 110.

Interconnects (not shown) in BT substrate 110 connect the contact pads 350 to contact pads 360 at the bottom surface of substrate 110. Solder balls 134 are formed on pads 360 by conventional techniques for attachment to PCB 130.

The size and spacing (pitch) of contact pads 136C on interposer 120 matches the size and the pitch of the contact pads on dies 124. If dies 124 are silicon integrated circuits, their CTE (coefficient of thermal expansion) matches the CTE of the interposer, so the pitch of contact pads 136C can

be small because the low thermal stresses at the interface between the dies and the interposer make it unnecessary to use large bumps **150** as would be desirable for a strong mechanical connection. The contact pads **340** on the bottom of the interposer match the top contact pads **350** of BT substrate **110**. For some fabrication technologies, the minimum dimensions are as shown in the following Table 1. The dimensions can typically be reduced if more expensive technologies are used.

TABLE 1

Contacts	Minimum pitch	Solder ball diameter	Solder ball height
Contact pads 136C	125 μm	75 μm	60 μm
Contact pads 340, 350	254 μm	150 μm (solder balls, not shown, joining pads 340 to 350)	120 μm
Contact pads 360	1.27 mm	0.75 mm (solder balls 134)	0.60 mm

Silicon interposer **120** can be manufactured using conventional techniques. See e.g. the aforementioned U.S. Pat. No. 6,322,903. Other techniques are described in U.S. patent application Ser. No. 10/410,929 filed on Apr. 9, 2003 by P. Halahan et al., entitled "Electroplating and electroless plating of conductive materials into openings, and structures obtained thereby", incorporated herein by reference. Still other techniques can possibly be used, whether known or to be invented. An exemplary manufacturing process is as follows. Vias **330** (FIG. 4) are etched in the top surface of silicon substrate **140** (e.g. monocrystalline silicon) by DRIE (deep reactive ion etching) to an exemplary depth $H_v=150$ μm . (The dimensions, etching processes, and other particulars are exemplary and not limiting.) The via diameter D_v is 25 μm to 100 μm . The via diameter DV is one of the parameters defining the diameter of contact pads **340** (FIG. 3), and DV is chosen large enough to provide the necessary mechanical strength for the protruding contact pads. Exemplary dimensions below will be given for $D_v=65$ μm . Silicon dioxide layer **410** is thermally grown on the wafer to a thickness of about 1 μm . A larger thickness can also be used to reduce the capacitance between substrate **140** and the metal features that will be fabricated in vias **330**. Barrier layer **420** of titanium-tungsten (TiW) is sputtered on oxide **410** to a thickness of 0.2 μm . A seed copper (Cu) layer **430.1** is sputtered on the wafer to a thickness sufficient to ensure a continuous copper coverage in the vias. Thicknesses of 0.5 μm to 2 μm are believed to be adequate, depending on the sputter technology. A dry photoresist film **440** is deposited on the wafer and patterned to expose the vias **330**.

Optionally, gold (Au) layer **444** and nickel (Ni) layer **448** are electroplated, in that order, to an exemplary thickness of 0.2 μm and 1.0 μm respectively.

Copper **430.2** is electroplated on nickel **448** to fill the vias **330** and possibly protrude out of the vias. In the electroplating of layers **444**, **448**, **430.2**, the cathode terminal (not shown) of the power source is placed at the periphery of wafer **140** in physical contact with seed layer **430.1**.

Optionally, nickel (Ni) layer **450** is electroplated on the top surface of copper layer **430.2** to an exemplary thickness of 0.5 μm .

Resist **440** is removed (FIG. 5). A wet copper etch removes the exposed portions of seed copper **430.1**, with nickel **450** acting as a mask. Nickel **450** protects copper **430.2** in vias **330**. Copper **430.2**, **430.1** can be etched laterally during the wet etch, but the lateral etch does not remove the copper over the vias **330** because the copper

extends laterally beyond the via edges. In those embodiments in which the nickel **450** is omitted, the copper etch may reduce the thickness of copper **430.2**, but this is acceptable if the copper protrusions above the vias are sufficiently thick. In either case, it is desirable for the top surface of copper **430.2** to be at or above the top surface of oxide **410** after the copper etch.

Then a CMP step (chemical mechanical polishing) is performed to remove copper **430.2**, nickel **448**, gold **444**, and TiW **420** off the top surface of substrate **140** (FIG. 6). The CMP stops on oxide **410**. The structure has a planar top surface.

In an alternative embodiment, the wet etch of copper **430.1** is omitted, and copper **430.1** is removed by the CMP step. The separate wet etch of copper **430.1** may be desirable however because it may shorten the more expensive CMP step, thus reducing the total manufacturing cost.

Oxide **410** can be patterned if desired. Metal layers **136** (FIG. 7) and dielectric layers **144** are deposited on the interposer wafer and patterned to provide interconnects and, possibly, other elements as described above. In some embodiments, metal **136** is copper and dielectric **144** is polyimide, but other materials can also be used. Some or all of dielectric layers **144** can be silicon dioxide, photosensitive benzocyclobutene (BCB), polybenzoxazole (PBO), or other materials. For a capacitor, a high dielectric constant material (such as Ta_2O_5) can be used. Aluminum, conductive polysilicon, and other materials can be used as layers **136**. Cavities **210** are formed in the top dielectric layer **144** to expose the contact pads **136C** provided by the top metal layer **136**. Solder wettable materials **710** (e.g. Ni and/or Au) can be plated on contact pads **136C** if desired.

Solder balls **720** are formed on contact pads **136C**, by any suitable technique. For example, solder paste can be deposited to cover the interposer wafer **120**, and then wiped off by a squeegee blade to force the solder into cavities **210** and remove it from the top surface of the top layer **144**. In some embodiments, interconnects **136** are made of copper, and contact pads **136C** are plated with a layer **710** of nickel or gold. Layer **710** does not dissolve in solder **720** and provides a barrier for the copper diffusion from interconnects **136**, so the melting temperature of solder **720** does not change when the solder is reflowed.

In some embodiments, the solder is not placed at this stage to avoid solder melting at high temperatures present in plasma wafer thinning processes described below in connection with FIG. 8. Whether or not the solder is placed at this stage or after the wafer thinning, the top dielectric layer **144** is sufficiently thick to accommodate the solder volume needed for a reliable bond to dies **124** (FIG. 1). In some embodiments, the top dielectric **144** is 50 μm thick. Cavities **210** are about 50 μm deep and have a diameter of about 75 μm .

Then the interposer wafer is thinned from the bottom to expose the gold **444**. See FIG. 8. The exposed metal provides the contact pads **340** (FIG. 3) that will be soldered to BT substrate **110**. The wafer thinning can be performed with any of the techniques described in the aforementioned U.S. Pat. No. 6,322,903 and U.S. patent application Ser. No. 10/410,929. See also U.S. Pat. No. 6,498,381 issued on Dec. 24, 2002 to Halahan et al. and incorporated herein by reference. In one embodiment, the wafer thinning includes a CF_4 plasma etch at atmospheric pressure. The wafer is held from the top by a vortex wafer holder (not shown) that does not touch the wafer except possibly at the wafer periphery. The holder emits gas vortices that create vacuum between the holder and the wafer but do not allow the wafer to touch

the top surface of the holder. The plasma etch exposes the oxide **410** and then etches the silicon **140**, oxide **410** and TiW **420** selectively to copper **430.1**. (Copper **430.1** is etched later as explained below.) The plasma etch etches silicon **140** faster than oxide **410**, so the oxide protrudes out of the silicon on the bottom surface of the wafer after the etch. In one embodiment, the final thickness "Tsif" (marked in FIG. **8**) of silicon substrate **140** is 100 μm , and it can be smaller (e.g. 35 μm). Oxide **410** and TiW **420** form 5 μm protrusions around the copper **430.1** below the silicon surface. If the solder **720** melting temperature is low, the solder can melt in this process and be blown away by the wafer holder's gas vortices. Therefore, in some embodiments the solder **720** is placed on the wafer after the wafer thinning and, possibly, after the wafer attachment to BT substrate **110**.

The plasma etch forms copper oxide (not shown) on the exposed portions of copper **430.1**. The copper oxide and the copper **430.1** are etched by a wet etch to expose gold **444**. The gold provides a solderable oxide-free surface. Nickel **448** will prevent copper diffusion from layer **430.2** into the solder. The copper diffusion may be undesirable because it increases the solder melting temperature. In other embodiments, the copper diffusion is desirable to achieve a certain solder hierarchy (the hierarchy of the melting temperatures of different solders) as explained below. In such embodiments, the etch of copper **430.1** can be omitted. Nickel **448** can also be omitted.

As stated above, gold **444** can be omitted. The etch of copper **430.1** will then expose nickel **448**.

In some embodiments, the copper **430.1** is not etched away. The copper oxide (not shown) on copper **430.1** can be removed by a wet etch. The copper oxide can also be removed by a solder flux during soldering of the interposer wafer to BT substrate **110** (the soldering operation is described below). Layers **444**, **448** can be omitted.

Metal contact pads **340** are metal protrusions formed by the metal layers **430.2**, **448**, **444**, **430.1**, **420** below the bottom surface of silicon **140**. In some embodiments, the height H_d of metal contact pads **340** is 50 μm .

A dielectric layer (not shown) can optionally be formed on the bottom surface of the interposer to cover the silicon **140** but not the metal contact pads **340**. The dielectric can be formed without photolithography. See the aforementioned U.S. Pat. Nos. 6,322,903 and 6,498,381 and U.S. patent application Ser. No. 10/410,929.

The interposer wafer can be diced if desired. The dicing can be performed at the same time as the interposer wafer thinning if vias were formed along the dicing lines (scribe lines) simultaneously with vias **330** at the stage of FIG. **4**. See U.S. Pat. No. 6,498,074 issued Dec. 24, 2002 to Siniaguine et al., entitled "THINNING AND DICING OF SEMICONDUCTOR WAFERS . . .", incorporated herein by reference.

In some embodiments, the interposer wafer is not diced. ICs **124** will be attached to the undiced interposer wafer.

In some embodiments, metal **430.2** does not fill the through-silicon vias. Metal **430.2** is a thin film deposited over the via sidewalls, and it can be part of a layer **136**. See the aforementioned U.S. Pat. No. 6,498,381. Also, in some embodiments the contact pads **340** do not protrude out of the bottom surface of the interposer.

BT substrate **110** (FIGS. **9** and **10**) is formed from one or more BT layers laminated in a conventional manner. Three layers **110.1**, **110.2**, **110.3** are shown, but any number of layers can be present. Thin film metal layers **910** (e.g. copper) are formed on top of BT layers **110.i** ($i=1, 2, 3$) and

on the bottom side of layer **110.1** in a conventional manner to provide signal routing paths and ground and power planes. Layers **910** are interconnected through vias in the BT layers **110.i** (i.e. **110.1**, **110.2**, **110.3**) using known techniques to provide conductive paths between contact pads **350** and contact pads **360**. The bottom metal layer **910** provides contact pads **360** (FIG. **3**) at the bottom surface of BT substrate **110**.

Top contact pads **350**, and the top metal layer **910**, are formed below the top BT layer **110.3**. In FIG. **9**, the top contact pads **350** and the top metal **910** are formed on BT layer **110.2**. Layer **110.3** has vias **210B** exposing the contact pads **350**. Vias **210B** form cavities in the top surface of BT substrate **110**. Silicon interposer contact pads **340** will be inserted into these cavities to form a reliable mechanical and electrical contact.

In one embodiment, each BT substrate cavity **210B** has a diameter $D_{cav}=150 \mu\text{m}$ to accommodate a 50 μm to 60 μm diameter D_c of the contact pads **340**. D_c can be calculated starting with the diameter D_v (FIG. **4**) of via **330**, by subtracting double the thickness of the layers **410**, **420**, **430.1**, **444**, **448**. The depth H_{cav} of each cavity **210B** (about equal to the thickness of layer **110.3**) is 50 μm for a 50 μm height H_d of contact pads **340** (H_{cav} is measured to the top surface of contact pads **350**).

Cavities **210B** are filled with solder paste **930**. In one embodiment, the solder paste is deposited to cover the BT substrate, and then is wiped off by a squeegee blade to force the solder into cavities **210B** and remove it from the top surface of BT layer **110.3**. The solder is chosen to have a high melting temperature to provide a desired solder hierarchy for subsequent solder attachment of dies **124** and PCB **130**. In some embodiments, the solder paste is a no-clean type NC253 available from AIM of Montreal, Canada. This paste incorporates solder flux but there is no need to clean the flux after the solder reflow.

No-flow underfill **940** (dielectric) is dispensed on BT substrate **110** at the future site of interposer **120**. In some embodiments, the underfill is type STAYCHIP™ 2078E available from Cookson Electronics, a company having an office in Georgia, the United States of America. This underfill performs both the underfill function and the solder flux function. The underfill can be dispensed with a dispensing system of type CAMELOT/SPEEDLINE 1818 available from Cookson Electronics.

Interposer wafer **120** is placed on BT substrate **110** (FIG. **10**). Protruding contact pads **340** enter the BT substrate cavities **210B** and contact the solder **930** but do not necessarily reach the metal **910** of contact pads **350**. A uniform height of contact pads **340** is not required for a good electrical contact.

Underfill **940** spreads out under the interposer. In the embodiment shown, the bottom surface of silicon **140** does not reach the BT substrate. Underfill **940** helps insulate the silicon from solder **930**. Therefore, it is unnecessary to form a dielectric layer on the bottom silicon surface.

The interposer placement can be performed with a placement tool of type SIPLACE F4 available from Siemens corporation of Germany. The placement tool picks up the interposer from the top by a vacuum holder **1010** schematically shown in FIG. **10**. The vacuum pick-up flattens the interposer if the interposer is warped. Dielectric **144** protects the interposer from being damaged by the holder. Other placement tools, with vacuum and non-vacuum holders, known or to be invented, can also possibly be used.

The structure is heated to reflow the solder paste **930** and cure the underfill **940**. The solder wets the bottom and side

surfaces of copper contact pads **340**. In one embodiment, the final value of the gap **G1** between the silicon **140** and the BT substrate **110** is 25 μm . The gap values of 5 to 10 μm and larger are believed to be appropriate to provide sufficient electrical insulation if no dielectric is formed on the bottom surface of silicon **140**. The contact **340** portion inside the vias **210B** is 25 μm high ($C1=25\ \mu\text{m}$ in FIG. **10**). The value **C1** is in the range from 10 μm to 45 μm in some embodiments.

If the solder **720** was placed on the interposer before the interposer attachment to BT substrate **110**, solder **720** may or may not be reflowed during this step depending on the solder **720** melting temperature.

Then vacuum holder **1010** releases the interposer.

In some embodiments, the vacuum holder releases the interposer before the reflow of solder paste **930**. The interposer stays in place due to a surface tension between silicon **140** and the underfill **940**. Multiple interposers can be placed on BT substrate **110**, and the solder reflow and underfill curing can be performed in a single heating step for all the interposers, after the vacuum holder **1010** is removed. A similar technique has previously been applied for flip-chip mounting of dies on a BT substrate, as described in M. Painaik and J. Hurtley, "Process Recommendations for Assembly of Flip Chips using No-flow Underfill", Technical Bulletin, Cookson Semiconductor.

FIG. **11** illustrates another embodiment. The BT substrate **110** is similar to the BT substrate of FIGS. **9** and **10**, but a metal layer **220** is formed on the bottom and sidewalls of each BT substrate cavity **210B**. Metal **220** is believed to improve the strength and the electrical conductivity of the solder bond between contact pads **340** and contact pads **350**. Metal layer **220** can be copper deposited on the BT substrate and patterned by lift-off or some other process. In FIG. **11**, metal **220** extends out of BT substrate cavities **210B** to the top surface of the BT layer **110.3** but does not provide any interconnects or other elements on the top surface of layer **110.3**. Metal **220** is present only in the immediate vicinity of each BT substrate cavity **210B**. Each contact pad **350** includes the portions of metal layers **910**, **220** on the bottom and sidewalls of the corresponding BT substrate cavity **210B**. In other embodiments, metal **220** provides an additional level of interconnects and/or a power or ground plane on layer **110.3**.

In the BT embodiment described above, the BT layers **110.1**, **110.2**, **110.3** are laminated on top of each other. Each layer **110.1**, **110.2** is a solid sheet placed on the structure in a solid form. In some embodiments, the top layer **110.3** is made from a material different from the material of layers **110.1**, **110.2**. For example, solder dam materials can be used, such as photoimageable polyimide, Dupont VACREL 8100, Dupont Flexible Photolamable Coverlay (PIC) 1000 & 2000, Shipley (Dynachem) DynaMASK 5000, Shipley ConforMASK 2500, and possibly others. Some of the solder dam materials (e.g. polyimide) can be deposited in a liquid (possibly viscous) form and then cured.

In some embodiments, solder **720** has a lower melting temperature than solder **930**. Therefore, solder **930** is not melted during the attachment of dies **124**.

In other embodiments, solder **720** initially has the same or higher melting temperature than solder **930**, but the melting temperature of solder **930** is increased during the attachment of interposer **120** to BT substrate **110**. The melting temperature of solder **930** becomes higher than the melting temperature of solder **720**. The melting temperature of solder **930** is increased because the copper from layer **220** and/or layer **350** dissolves in solder **930**. In the embodiment of FIG.

12, copper **430.1** was not etched away as in FIG. **8**, so copper **430.1** can also dissolve in solder **930**. In some embodiments, solders **720**, **930** are initially the same solder (i.e. the same material), which simplifies the wafer fabrication. For example, a eutectic solder Sn/Ag3.0/Cu0.5 (known as type LF128 from AIM) can be used.

Metal contact pads **136C** can be formed from a material other than copper. This may be desirable if solder **720** is placed on the interposer before the interposer attachment to BT substrate **110**, because copper in pads **136C** could diffuse in solder **720** during the interposer attachment to the BT substrate and increase the solder **720** melting temperature. In some embodiments, interconnects **136** are made of copper, but contact pads **136C** are plated with a layer **710** of nickel or gold. Layer **710** does not dissolve in solder **720** and provides a barrier for the copper diffusion from interconnects **136**, so the melting temperature of solder **720** does not change. In other embodiments, the melting temperature of solder **720** changes during the attachment of the interposer to substrate **110**, but the melting temperature of solder **720** remains below the melting temperature of solder **930**.

FIGS. **13–14** illustrate a possible manufacturing sequence with multiple die levels **124.1**, **124.2**, **124.3** attached to the packaging substrate. The packaging substrate is manufactured as in FIG. **10**, **11** or **12**. The interposer vias are marked **330.0** (instead of **330** as in FIG. **3**), the contact pads at the bottom of the interposer are marked **340.0**, and the solder at the top is marked **720.0**. The cavities at the top of the interposer are marked **210.0**.

Each die **124.1** has one or more metalized through vias **330.1** formed in the die's semiconductor substrate **140.1** (e.g. monocrystalline silicon). Each via **330.1** passes between the top and bottom surfaces of substrate **140.1**. Conductive paths are provided from contact pads at the top of each die **124.1** to contact pads **340.1** at the bottom of the die through the vias **330.1**. Contact pads **340.1** protrude out of the respective vias **330.1**. The dies **124.1** can be manufactured using the same techniques as described above for interposer **120** (involving the wafer thinning to expose the contact pads **340.1**). Each die may have the same general structure as interposer **120** in FIGS. **10–12**. Of course, the circuitry in dies **124.1** does not have to be identical to the interposer circuitry, and different dies **124.1** may differ from each other. Also, contact pads **340.1** may have smaller dimensions, and may be placed closer to each other, as they do not have to meet the BT substrate dimension requirements. Pads **340.1** can be copper/nickel/gold structures as in FIG. **12**, or they can be made from other materials. The metal in vias **330.1** is insulated from substrate **140.1** by a dielectric **410** (FIG. **12**).

In some embodiments, dies **124.1** and interposer **120** have devices (e.g. transistors, diodes, and others) manufactured at the top surface (active surface). Transistor source/drain regions, diodes' cathodes and anodes, and other elements can be formed in semiconductor substrates **140.0**, **140.1** of interposer **120** and dies **124.1** at the top surface of the respective substrates. Cavities **210.1** are formed in the top surface of dies **124.1**, and solder balls **720.1** are formed in the cavities on the dies' top contact pads, possibly before the wafer thinning operation exposing the contact pads **340.1**, as in FIGS. **10–12**.

Dies **124.2** may be similar to dies **124.1**. Dies **124.2** include metalized vias **330.2** in semiconductor substrates **140.2**, and contact pads **340.2** protruding out of the vias on the bottom. Dies **124.2** may contain devices (e.g. transistors, diodes, and others) manufactured at the top surface (active surface) of semiconductor substrates **140.2**. Transistor

11

source/drain regions and other elements can be formed in semiconductor substrates **140.2** at the top surface. Cavities **210.2** are formed in the top surface of dies **124.2**, and solder balls **720.2** are formed in the cavities on the dies' top contact pads, possibly before the wafer thinning operation exposing the contact pads **340.2**, as in FIGS. **10–12**.

The third level dies **124.3** are like dies **124** in FIGS. **2** and **3**. The semiconductor substrates of dies **124.3** are marked **140.3**. The dies' active surface is the bottom surface.

The manufacturing sequence is shown in FIG. **14**. Interposer **120** is attached to BT substrate **110** as described above with respect to FIGS. **10–12** (step **1420**). During this step, the melting temperature of solder **930** (FIGS. **10–12**) increases and becomes higher than the melting temperature of solders **720.0**, **720.1**, **720.2**. Solder **720.0** can be placed on the interposer after the attachment to BT substrate **110**. If solder **720.0** is placed before the attachment, solder **720.0** may or may not be melted during the attachment step, but its melting temperature does not change because this solder is not in contact with copper (there is no copper on the top surface of the top contact pads of the interposer). The melting of solder **720.0** does not present a problem because the dies **124.1** have not yet been attached to the interposer. If solder **720.0** is placed on the interposer after the attachment to the BT substrate, solder **720.0** can be reflowed in a separate step before the attachment of dies **124.1**. The solder reflow does not increase the melting temperature of solder **720.0**.

In some embodiments, all of solders **720.0**, **720.1**, **720.2**, **930** are initially the same material. In an illustrative example, the solders are eutectic type LF128 described above, with the initial melting temperature of 218°C . The melting temperature of solder **930** increases to about 230°C . in step **1420**.

At step **1430**, dies **124.1** are soldered to interposer **120** with solder **720.0**, at a temperature of about 218°C . or higher, but below 230°C . not to melt the solder **930**. Contact pads **340.1** are inserted into cavities **210.0** of interposer **120**. The copper from contact pads **340.1** dissolves in solder **720.0** and increases its melting temperature to about 230°C . Solder **720.1** may be placed on dies **124.1** in advance and may melt, but its melting temperature does not increase because the solder **720.1** is not in contact with copper or other material that could increase the solder melting temperature (the top surface portions of the top contact pads of die **124.1** are made of suitable materials to ensure that the solder melting temperature does not increase).

At step **1440**, dies **124.2** are attached to dies **124.1** with solder **720.1**, at a temperature below 230°C . Contact pads **340.2** are inserted into cavities **210.1** of dies **124.1**. Solders **720.0** and **930** do not melt. The melting temperature of solder **720.1** is increased to about 230°C . due to the diffusion of copper from contact pads **340.2**.

At step **1450**, dies **124.3** are flip-chip attached to dies **124.2** with solder **720.2**, at a temperature below 230°C . Bumps **150** are inserted into cavities **210.2** of dies **124.2**. Solders **930**, **720.0**, **720.1** do not melt. If desired, bumps **150** may include copper to increase the melting temperature of solder **720.2**. The higher melting temperature may be desirable to prevent the solder melting during the attachment of BT substrate **110** to PCB **130** (FIG. **3**). For example, the solder **134** used for the PCB attachment may be the same material (LF128) as the solders **930**, **720.0**, **720.1**, **720.2**.

Many variations are possible. For example, any number of dies can be used at each level. Also, one or more dies **124.2** can be attached directly to interposer **120**, i.e. there may be three levels of dies over one interposer area but only two

12

levels of dies over another interposer area. Any number of die levels can be present in different interposer areas. Dies **124.3** may be omitted. Dies **124.2** may have no contact pads on the top, or they may have contact pads on the top which can be wire bonded to other substrates.

Other solder types and melting temperatures can be used, and materials other than copper can be used to increase the melting temperatures. Different materials and contact pad structures can be used in different dies. Different semiconductor substrates can be different semiconductor materials in the same structure.

Varying the solder melting temperature to achieve a desired solder hierarchy is not limited to the interposer structures, but may be used in other semiconductor packages, known or to be invented, with or without interposers.

FIG. **15** shows another manufacturing sequence. See also the aforementioned U.S. Pat. No. 6,322,903. Below, numerals **124.2**, **124.1**, **120** denote both the dies as shown in FIG. **13** and the wafers from which the dies are obtained. Dies **124.3** are attached to wafer **124.2** (step **1510**) before the wafer **124.2** is thinned and diced. Contacts **340.2** are not yet exposed. Then the wafer **124.2** is thinned to expose the contact pads **340.2** (step **1520**), and diced (step **1524**). Then dies **124.2** are attached to wafer **124.1** (step **1530**) before the wafer is thinned and diced. Then wafer **124.1** is thinned to expose contact pads **340.1** (step **1540**), and diced (step **1544**). Then dies **124.1** are attached to interposer wafer **120** (step **1550**) before the interposer wafer is thinned and diced. Then interposer wafer **120** is thinned to expose the contact pads **340.0** (step **1560**), and diced (step **1564**). Then the interposer is attached to BT substrate **110** (step **1570**). All the thinning and dicing operations (steps **1520**, **1524**, **1540**, **1544**, **1560**), **1564** are performed when the wafer or die being thinned has been attached to other dies. The structure has therefore a greater mechanical strength and greater thermal dissipation capabilities for the thinning operation. Plasma and non-plasma thinning process can be used, and the solder can be protected with suitable underfill or other coatings. All the solders can be initially the same material. The solder attachment increases the melting temperature of each solder being reflowed, so the solder does not melt in the subsequent soldering steps, as in FIG. **14**.

The invention is not limited to any particular manufacturing sequence however.

In some embodiments, the same dimensions are obtained for the attachment of dies **124.1**, **124.2**, **124.3** as for the attachment between the BT substrate and the interposer. More particularly, the final value of the gap between the silicon **140.1** and interposer **120** or between the silicon **140.2** and the dies **124.1** is $25\ \mu\text{m}$ (gap values of 5 to $10\ \mu\text{m}$ and larger are believed to be appropriate to provide sufficient electrical insulation if no dielectric is formed on the bottom surface of silicon **140.1** or **140.2**); the portions of contacts **340.1**, **340.2**, **150** inside the respective cavities **210.0**, **210.1**, **210.2** are $25\ \mu\text{m}$ high (note dimension C1 in FIG. **10**). This value is in the range from $10\ \mu\text{m}$ to $45\ \mu\text{m}$ in some embodiments. The top dielectric layer on interposer **120** and dies **124.1**, **124.2** is $50\ \mu\text{m}$ thick. Other dimensions can also be used.

Underfill (not shown) can be injected between the interposer and the dies **124.1**, between the dies **124.1** and **124.2**, and between the dies **124.2** and **124.3** using known techniques. No flow underfill can also be used.

FIGS. **16A**, **16B** illustrate an embodiment in which a contact pad **350** (made from metal **910**) covers only a portion of the bottom surface of opening **210B** in BT substrate **110**. FIG. **16B** is a top view, and FIG. **16A** shows

a vertical cross section along the line A—A in FIG. 16B. Only portions of interposer 120 and substrate 110 are shown, with only one contact 340 and opening 210B, though many such contacts and openings can be present. The contact 340 at the bottom of interposer 120 is shown to be formed by metal 430 in through silicon via 330, but the contact 340 may have any structure, including the structures of FIGS. 10–13, the structures used for contacts 150 of FIGS. 1–2, and other structures known or to be invented. Substrate 110 can be a non-BT substrate, e.g. it can be a PCB or some other integrated circuit packaging substrate, or an integrated circuit die or an integrated circuit wafer (e.g. such as a die 124.1 or 124.2 in FIG. 13). Substrate 120 can be a semiconductor integrated circuit or a non-semiconductor packaging substrate.

The advantage of the contact pad 350 as in FIGS. 16A, 16B is that the solder 930 does not wet the dielectric 110.2 on the bottom of opening 210B. Therefore, more solder will gather closer to contact 340, and the solder will reach higher up along the contact surface. This is believed to improve the mechanical strength and electrical conductivity of the solder joint. Less solder is needed for good mechanical strength and electrical conductivity, so the diameter of opening 230B can be reduced (this diameter controls the solder volume by controlling the volume of the solder paste in opening 230B).

In FIG. 16B, only one conductive line 910 extends from contact pad 350, but many lines 910 can extend from the contact pad. The width W1 (20–30 μm in some embodiments) of line 910 is shown as smaller than the diameter of pad 350, but this is not necessary. W1 can be any number, with any relationship between W1 and pad 350. Also, the invention is not limited to the circular shapes of pad 350 and opening 210B. Any shapes can be employed.

In FIG. 17, contact pad 350 includes two conductive layers 910.1, 910.2. The bottom layer 910.1 covers the whole bottom of opening 230B, and the top layer 910.2 covers only a portion of the bottom of opening 230B. Bottom layer 910.1 is less solder wettable than the top layer 910.2. In still other embodiments, bottom layer 910.1 does not cover the whole bottom of opening 230B, and the top layer 910.2 covers a smaller portion of the bottom of opening 230B than the top layer 910.1.

FIGS. 18, 19 illustrate possible shapes of solder 930 in the embodiments of FIGS. 16A, 16B, 17 after the solder reflow before the attachment of interposer 120 to the BT substrate. The solder shape is an approximation; the solder is assumed to wet only the pad 350, ignoring the line 910 extending from the pad (see FIG. 16B). It is assumed that the solder shape is a sphere truncated at the bottom, of some diameter Ds. Symbol Hs denotes the solder ball height above contact pad 350. Hc is the depth of cavity 210B. Db is the diameter of pad 350. Dc is the diameter of cavity 210B (shown as Dcav in FIG. 9).

Assuming the solder paste filled the cavity before the solder reflow, and ignoring the thickness of pad 350, the solder paste volume Vc was the cavity volume, i.e.:

$$V_c = \pi * D_c^2 * H_c / 4 \tag{1}$$

We will assume that the solder paste was half solder and half flux. After the reflow, the solder volume Vs is therefore one half of Vc, i.e.

$$V_s = \pi * D_c^2 * H_c / 8 \tag{2}$$

Also, Vs is the volume of the truncated solder sphere, and therefore:

$$V_s = \pi * D_s^3 / 6 - \pi * (3 * D_b^2 + 4 * h^2) * h / 24 \tag{3}$$

where $h = D_s - H_s$.

From (2) and (3) we obtain:

$$4 * D_s^3 - (3 * D_b^2 + 4 * h^2) * h = 3 * D_c^2 * H_c \tag{4}$$

where

$$D_s = (4 * h^2 + D_b^2) / (4 * h) \tag{5}$$

and, as noted above,

$$H_s = D_s - h \tag{6}$$

Example: suppose Dc=150 μm, Hc=50 μm, Db=80 μm. From equation (4):

$$h = 20.57 \mu\text{m}$$

From equation (5):

$$D_s = 98.35 \mu\text{m}$$

From equation (6):

$$H_s = 77.78 \mu\text{m}$$

Other examples are given in the following Table 2 for Dc=150 μm. The dimensions are in micrometers. Tilda (“~”) denotes approximation.

TABLE 2

Db	Ds	Hs	Solder Profile in FIG. 19
65	~96	~83	930A
80	~98	~78	930B
100	~105	~69	930C
150	~170	~45	930D

The invention is not limited to the embodiments described above. For example, non-eutectic solders can be used. The “melting temperature” is any temperature as high or higher than the solidus and but not higher than the liquidus. As is known, the solidus is the highest temperature at which 100% of the solder is solid, i.e. the solder is just beginning to melt. The liquidus is the lowest temperature at which 100% of the solder is liquid. For a eutectic solder, the solidus and the liquidus are the same.

Also, in some embodiments, the cavities 210B (FIG. 9) extend through two or more BT layers, for example, through layers 110.3 and 110.2. Contact pads 350 can thus be formed from the metal layer 910 located between the BT layers 110.1, 110.2. The layer 910 on BT layer 110.2 can be used for interconnects, power or ground planes, or other elements as discussed above. The invention is not limited to particular materials, dimensions and processes. For example, anisotropic adhesive, conductive epoxy, and/or thermocompression can be used instead of solder. Bumps 150 or contacts 340, 340.0, 340.1, 340.2 may include a solder layer. For example, they may include copper pillars with solder thereon, or they can be solder bumps. The invention is applicable to non-silicon semiconductor integrated circuits. The integrated circuits can be entire wafers or dice obtained by dicing the wafers.

The interposer may include capacitors having a capacitance of 5.0 pF or higher. For example, capacitance values of 10 pF, 100 pF, or higher have been used on circuit boards to decouple the power lines from the ground lines or for other purposes, and such capacitors can be manufactured in the interposer. Resistors having resistance values of 10 Ω and higher (e.g. 50 Ω, 100 Ω, or 150 Ω) are used on circuit boards for line termination and other purposes, and they can be manufactured in the interposer. Inductors having inductance values of 100 nH or higher are commonly used on circuit boards and can be manufactured in the interposer. The invention is not limited to particular capacitance, resis-

15

tance or inductance values. Other embodiments and variations are within the scope of the invention, as defined by the appended claims.

The invention claimed is:

1. A manufacturing method comprising:

(1) obtaining a first integrated circuit structure comprising:

a semiconductor substrate;

one or more first conductive contact pads protruding out at a surface of the first integrated circuit structure;

(2) obtaining a first substrate comprising a circuit which comprises one or more first conductive contact pads, wherein at least a portion of each of the one or more first contact pads of the first substrate is located in a corresponding via in a surface of the first substrate, the portion having a first surface facing a sidewall of the via and a second surface opposite to the first surface, the second surface facing an interior of the via and extending upward along the sidewall;

(3) inserting the protruding first contact pads of the first integrated circuit structure into the corresponding vias of the first substrate and attaching the protruding first contact pads of the first integrated circuit structure to the first contact pads of the first substrate.

2. The method of claim 1 wherein the operation (3) is performed without melting the protruding first contact pads of the first integrated circuit structure.

3. The method of claim 2 wherein in the operation (3) the first contact pads of the first integrated circuit structure are soldered to the first contact pads of the first substrate.

4. The method of claim 1 wherein an outer protruding surface of the first contact pads of the first integrated circuit structure is made of copper and/or gold and/or nickel.

5. The method of claim 1 wherein the first substrate comprises a semiconductor substrate.

6. The method of claim 1 wherein the first substrate is an integrated circuit packaging substrate which does not comprise a semiconductor substrate.

7. The method of claim 1 wherein the first substrate is a printed circuit board.

8. The method of claim 1 wherein in the operation (3) the attachment is performed without solder with thermal or thermosonic compression.

9. The method of claim 1 wherein after the operation (3) a spacing between the bottom surface of the semiconductor substrate and the top surface of the first substrate is at least 5 μm .

10. The method of claim 1 wherein at least a portion of the bottom surface of the semiconductor substrate is not covered by any dielectric layer in the first integrated circuit structure.

11. The method of claim 1 wherein at least a portion of the bottom surface of the semiconductor substrate is covered by a dielectric in the first integrated circuit structure.

12. A manufacturing method comprising:

(1) obtaining a first integrated circuit structure comprising:

a semiconductor substrate;

one or more first conductive contact pads protruding out at a surface of the first integrated circuit structure;

(2) obtaining a first substrate comprising a circuit which comprises one or more first conductive contact pads, wherein at least a portion of each of the one or more first contact pads of the first substrate is located in a corresponding via in a surface of the first substrate;

(3) inserting the protruding first contact pads of the first integrated circuit structure into the corresponding vias of the first substrate and attaching the protruding first

16

contact pads of the first integrated circuit structure to the first contact pads of the first substrate; wherein in the operation (3) at least 10 μm of each protruding first contact pad is inside the corresponding via.

13. The method of claim 1 wherein the first integrated circuit structure is an interposer that comprises no semiconductor circuit elements in the semiconductor substrate.

14. The method of claim 1 wherein the first integrated circuit structure comprises a semiconductor circuit element in the semiconductor substrate.

15. A manufacturing method comprising:

(1) obtaining a first integrated circuit structure comprising:

a semiconductor substrate;

one or more first conductive contact pads protruding out at a surface of the first integrated circuit structure;

(2) obtaining a first substrate comprising a circuit which comprises one or more first conductive contact pads, wherein at least a portion of each of the one or more first contact pads of the first substrate is located in a corresponding via in a surface of the first substrate;

(3) inserting the protruding first contact pads of the first integrated circuit structure into the corresponding vias of the first substrate and attaching the protruding first contact pads of the first integrated circuit structure to the first contact pads of the first substrate;

wherein each first contact pad of the first substrate covers a bottom and entire sidewalls of the corresponding via.

16. A manufacturing method comprising:

(1) obtaining a first integrated circuit structure comprising:

a semiconductor substrate;

one or more first conductive contact pads protruding out at a surface of the first integrated circuit structure;

(2) obtaining a first substrate comprising a circuit which comprises one or more first conductive contact pads, wherein at least a portion of each of the one or more first contact pads of the first substrate is located in a corresponding via in a surface of the first substrate;

(3) inserting the protruding first contact pads of the first integrated circuit structure into the corresponding vias of the first substrate and attaching the protruding first contact pads of the first integrated circuit structure to the first contact pads of the first substrate;

(4) obtaining a second integrated circuit structure comprising:

a semiconductor substrate;

one or more first conductive contact pads protruding out at a surface of the second integrated circuit structure;

wherein the first integrated circuit structure further comprises one or more second conductive contact pads, wherein at least a portion of each of the one or more second contact pads of the first integrated circuit structure is located in a corresponding via in a surface of the first integrated circuit structure;

wherein the method further comprises:

(5) inserting the protruding first contact pads of the second integrated circuit structure into the corresponding vias of the first integrated circuit structure and attaching the protruding first contact pads of the second integrated circuit structure to the second contact pads of the first integrated circuit structure.

17. The method of claim 16 wherein the first contact pads of the first integrated circuit structure are located on a first side of the first integrated circuit structure, and the second contact pads of the first integrated circuit structure are

17

located on a second side of the first integrated circuit structure, the first side being opposite to the second side.

18. A manufacturing method comprising:

- (1) obtaining a first integrated circuit structure comprising:
 - a semiconductor substrate;
 - one or more first conductive contact pads protruding out at a surface of the first integrated circuit structure;
 - (2) obtaining a first substrate comprising a circuit which comprises one or more first conductive contact pads, wherein at least a portion of each of the one or more first contact pads of the first substrate is located in a corresponding via in a surface of the first substrate;
 - (3) inserting the protruding first contact pads of the first integrated circuit structure into the corresponding vias of the first substrate and attaching the protruding first contact pads of the first integrated circuit structure to the first contact pads of the first substrate;
- wherein each first contact pad of the first integrated circuit structure is provided by a conductor formed in a corresponding through via in the semiconductor substrate and protruding out of the through via.

19. The method of claim 18 wherein the first contact pads of the first integrated circuit structure protrude out at the surface which is opposite to an active surface of the first integrated circuit structure.

20. The method of claim 1 wherein in the operation (3) the first contact pads of the first integrated circuit structure are soldered to the first contact pads of the first substrate.

21. The method of claim 20 wherein in the operation (3) the first contact pads of the first integrated circuit structure are soldered to the second surfaces of the portions of the first contact pads of the first substrate.

22. The method of claim 1 wherein in the operation (3) the protruding first contact pads of the first integrated circuit structure are inserted into the corresponding vias deeper than at least tops of the second surfaces of portions of the first contact pads of the first substrate.

23. The method of claim 1 wherein the operation (2) comprises:

18

forming a dielectric layer which is part of the first substrate, wherein each said via is a via in the dielectric layer; and then

forming a conductive layer over the dielectric layer to provide at least said portions of the first contact pads of the first substrate.

24. A manufacturing method comprising:

- (1) obtaining a first integrated circuit structure comprising:
 - a semiconductor substrate;
 - one or more first conductive contact pads protruding out at a surface of the first integrated circuit structure;
 - (2) obtaining a first substrate comprising a circuit which comprises one or more first conductive contact pads, wherein at least a portion of each of the one or more first contact pads of the first substrate is located in a corresponding via in a surface of the first substrate, wherein obtaining the first substrate comprises:
 - (2A) forming a dielectric layer which is part of the first substrate, wherein each said via is a via in the dielectric layer; and then
 - (2B) forming a conductive layer on a sidewall of each said via to provide at least a first portion of each first contact pad of the first substrate;
 - (3) inserting the protruding first contact pads of the first integrated circuit structure into the corresponding vias of the first substrate and attaching the protruding first contact pads of the first integrated circuit structure to the first contact pads of the first substrate.

25. The method of claim 24 wherein each first contact pad of the first substrate comprises a second portion formed before operation (2A).

26. The method of claim 24 wherein each first contact pad of the first substrate comprises a second portion underlying the dielectric layer.

27. The method of claim 24 wherein each first contact pad of the first substrate comprises a portion provided by said conductive layer on a bottom of the corresponding via.

* * * * *