



US008633070B2

(12) **United States Patent**
Fung et al.

(10) **Patent No.:** **US 8,633,070 B2**
(45) **Date of Patent:** **Jan. 21, 2014**

(54) **LIGHTLY DOPED SOURCE/DRAIN LAST METHOD FOR DUAL-EPI INTEGRATION**

(75) Inventors: **Ka-Hing Fung**, Hsinchu (TW); **Haiting Wang**, Hsinchu (TW); **Han-Ting Tsai**, Kaoshiung (TW)

(73) Assignee: **Taiwan Semiconductor Manufacturing Company, Ltd**, Hsin-Chu (TW)

(*) Notice: Subject to any disclaimer, the term of this patent is extended or adjusted under 35 U.S.C. 154(b) by 319 days.

(21) Appl. No.: **12/716,100**

(22) Filed: **Mar. 2, 2010**

(65) **Prior Publication Data**

US 2011/0193179 A1 Aug. 11, 2011

Related U.S. Application Data

(60) Provisional application No. 61/303,039, filed on Feb. 10, 2010.

(51) **Int. Cl.**
H01L 21/84 (2006.01)

(52) **U.S. Cl.**
USPC **438/163**; 257/E21.64; 257/E21.634

(58) **Field of Classification Search**
USPC 438/163; 257/E21.64
See application file for complete search history.

(56) **References Cited**

U.S. PATENT DOCUMENTS

5,504,031	A *	4/1996	Hsu et al.	438/231
5,631,485	A *	5/1997	Wei et al.	257/344
5,874,343	A *	2/1999	Fulford et al.	438/305
6,071,783	A *	6/2000	Liang et al.	438/301
6,153,455	A	11/2000	Ling et al.	
6,171,910	B1 *	1/2001	Hobbs et al.	438/275
6,323,077	B1	11/2001	Guo	
6,429,084	B1 *	8/2002	Park et al.	438/305
7,098,514	B2 *	8/2006	Oh et al.	257/384
2008/0277735	A1 *	11/2008	Ko et al.	257/369
2009/0039389	A1 *	2/2009	Tseng et al.	257/190
2009/0121256	A1 *	5/2009	Shin	257/190

OTHER PUBLICATIONS

Quirk et al., "Semiconductor Manufacturing Technology", 2001. Prentice-Hall, Inc.; pp. 205-222.*

* cited by examiner

Primary Examiner — Allen Parker

(74) *Attorney, Agent, or Firm* — Haynes and Boone, LLP

(57) **ABSTRACT**

An integrated circuit device and method for fabricating the integrated circuit device is disclosed. The method involves providing a substrate; forming a gate structure over the substrate; forming an epitaxial layer in a source and drain region of the substrate that is interposed by the gate structure; and after forming the epitaxial layer, forming a lightly doped source and drain (LDD) feature in the source and drain region.

20 Claims, 5 Drawing Sheets

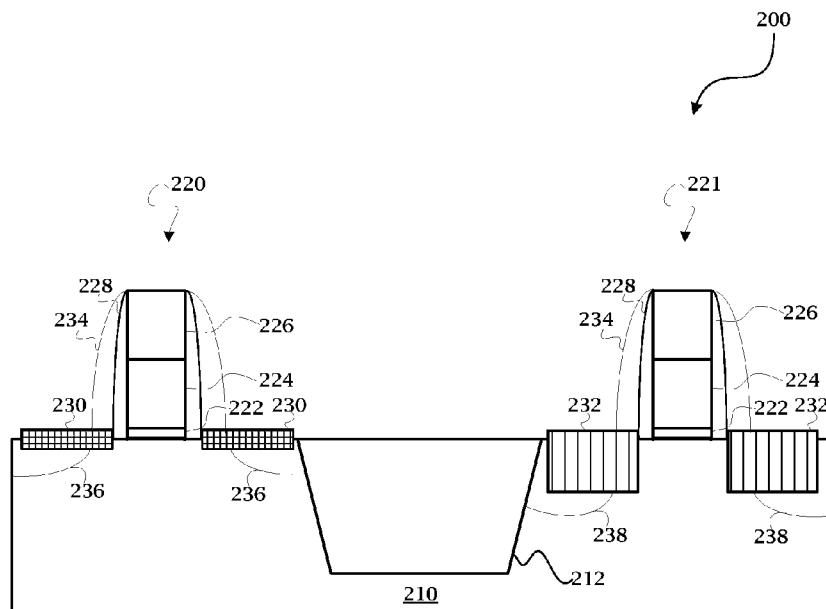

100
↘

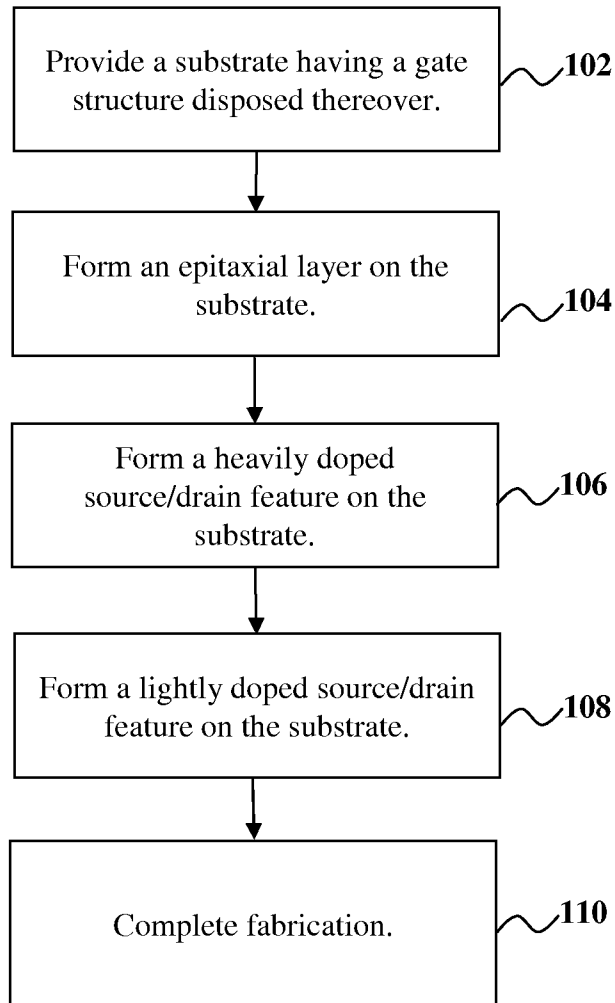

FIG. 1

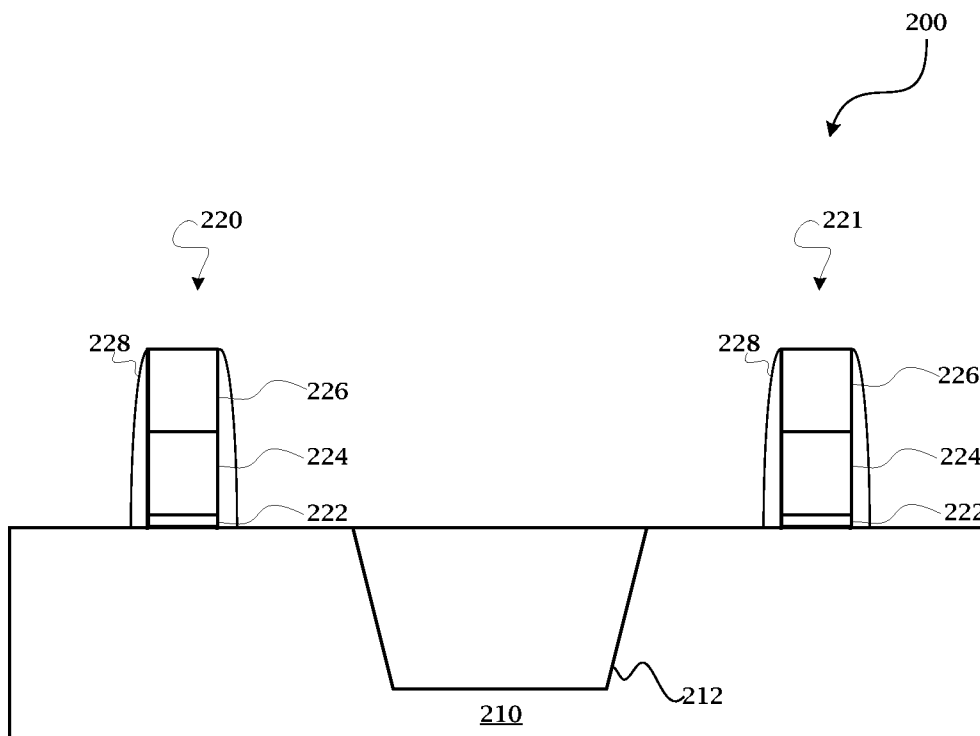

FIG. 2

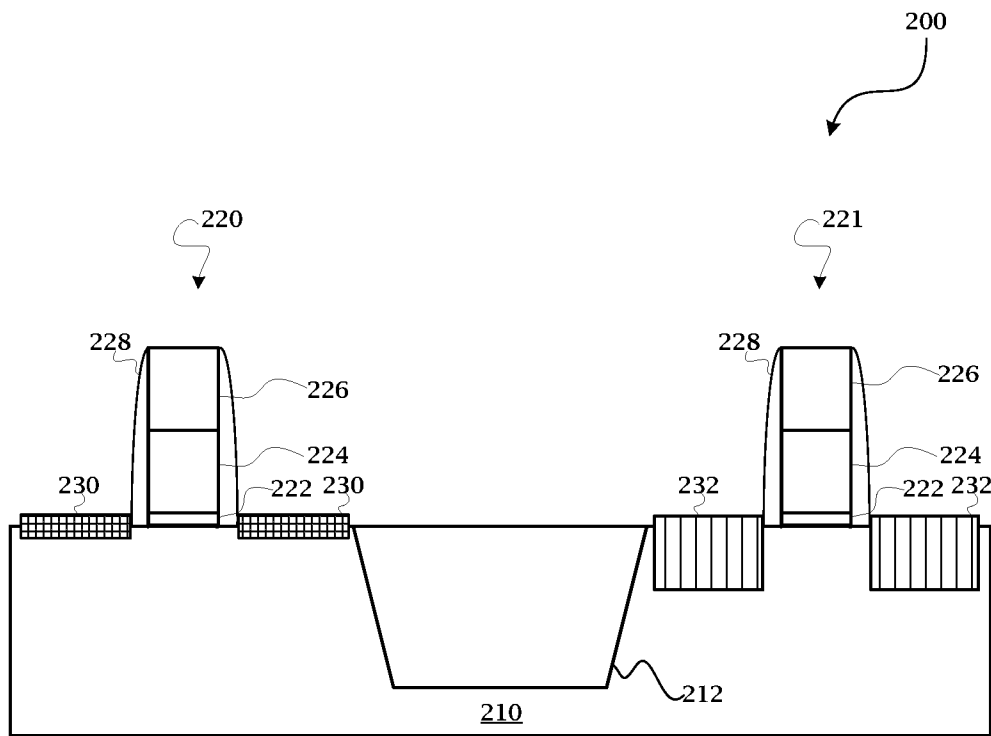

FIG. 3

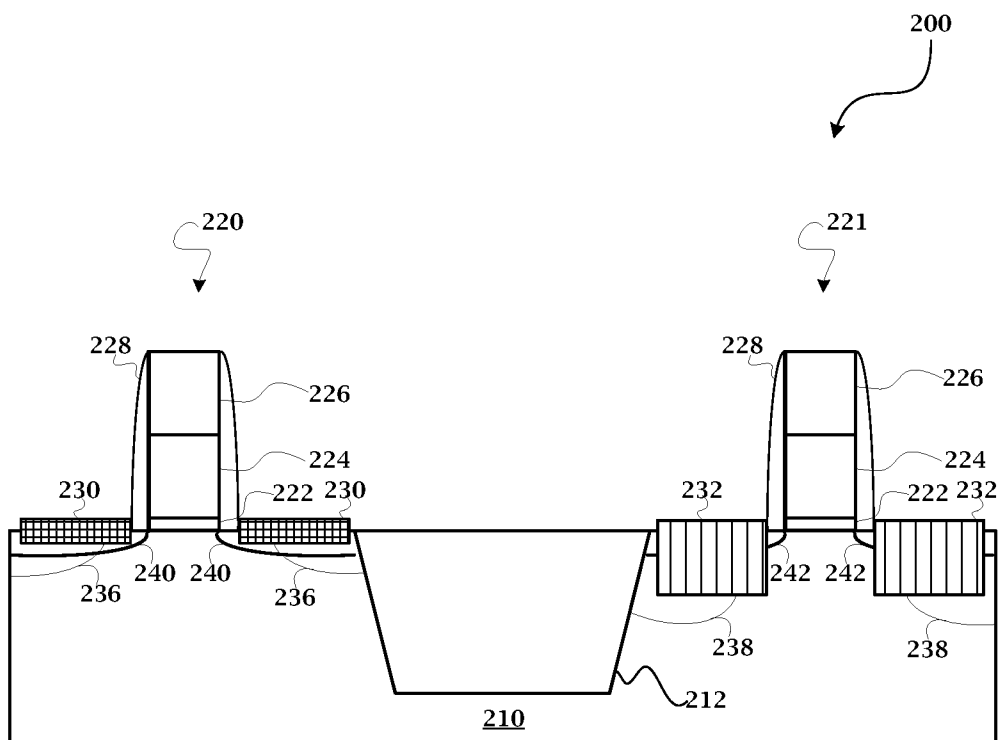

FIG. 5

1

LIGHTLY DOPED SOURCE/DRAIN LAST METHOD FOR DUAL-EPI INTEGRATION

PRIORITY DATA

This application claims priority to Provisional U.S. Patent Application Ser. No. 61/303,039, filed on Feb. 10, 2010, the entire disclosure of which is incorporated herein by reference.

BACKGROUND

The semiconductor integrated circuit (IC) industry has experienced rapid growth. In the course of IC evolution, functional density (i.e., the number of interconnected devices per chip area) has generally increased while geometry size (i.e., the smallest component (or line) that can be created using a fabrication process) has decreased. This scaling down process generally provides benefits by increasing production efficiency and lowering associated costs. Such scaling down has also increased the complexity of processing and manufacturing ICs and, for these advances to be realized, similar developments in IC manufacturing are needed.

For example, as semiconductor devices, such as metal-oxide-semiconductor field-effect transistors (MOSFETs), are scaled down through various technology nodes, strained source/drain features have been implemented using epitaxial (epi) semiconductor materials to enhance carrier mobility and improve device performance. Fabricating a MOSFET could include epitaxially growing a silicon layer in a source and drain region of an n-type device, and epitaxially growing a silicon germanium layer (SiGe) in a source and drain region of a p-type device. This can be referred to as a dual-epi process. Conventional techniques form lightly doped source and drain (LDD) regions for the n-type and p-type devices, respectively, prior to the dual-epi process (for example, before forming the Si epi and SiGe epi layers). Although existing approaches for forming LDD regions for IC devices have been generally adequate for their intended purposes, they have not been entirely satisfactory in all respects.

SUMMARY

The present disclosure provides for many different embodiments. According to one of the broader forms of the invention, a method includes providing a substrate; forming a gate structure over the substrate; forming an epitaxial layer in a source and drain region of the substrate that is interposed by the gate structure; and after forming the epitaxial layer, forming a lightly doped source and drain (LDD) feature in the source and drain region.

According to another of the broader forms of the invention, a method includes forming a first gate structure and a second gate structure over a substrate; forming an epitaxial layer of a first material in a source and drain region of the substrate that is interposed by the first gate structure; forming an epitaxial layer of a second material in another source and drain region of the substrate that is interposed by the second gate structure; and after forming the epitaxial layers, forming lightly doped source and drain (LDD) features in the source and drain regions.

According to another of the broader forms of the invention, an apparatus includes: a substrate; a gate stack disposed on the substrate that interposes a source and drain region of the substrate; and spacers disposed on sidewalls of the gate stack. An epitaxial layer, lightly doped source and drain (LDD) feature, and heavily doped source and drain (HDD) feature are in the source and drain region of the substrate. The epi-

2

taxial layer is aligned with an edge of the spacers, the LDD feature is adjacent the spacers, and the HDD feature is spaced away from the edge of the spacers.

BRIEF DESCRIPTION OF THE DRAWINGS

The present disclosure is best understood from the following detailed description when read with the accompanying figures. It is emphasized that, in accordance with the standard practice in the industry, various features are not drawn to scale and are used for illustration purposes only. In fact, the dimensions of the various features may be arbitrarily increased or reduced for clarity of discussion.

FIG. 1 is a flow chart of a method for fabricating an integrated circuit device according to aspects of the present disclosure; and

FIGS. 2-5 are various cross-sectional views of embodiments of an integrated circuit device during various fabrication stages according to the method of FIG. 1.

DETAILED DESCRIPTION

The present disclosure relates generally to integrated circuit device and methods for manufacturing integrated circuit devices, and more particularly, to methods for forming lightly doped source and drain features of integrated circuit devices.

It is understood that the following disclosure provides many different embodiments, or examples, for implementing different features of the invention. Specific examples of components and arrangements are described below to simplify the present disclosure. These are, of course, merely examples and are not intended to be limiting. For example, the formation of a first feature over or on a second feature in the description that follows may include embodiments in which the first and second features are formed in direct contact, and may also include embodiments in which additional features may be formed between the first and second features, such that the first and second features may not be in direct contact. In addition, the present disclosure may repeat reference numerals and/or letters in the various examples. This repetition is for the purpose of simplicity and clarity and does not in itself dictate a relationship between the various embodiments and/or configurations discussed.

With reference to FIGS. 1 and 2-5, a method **100** and a semiconductor device **200** are collectively described below. The semiconductor device **200** illustrates an integrated circuit, or portion thereof, that can comprise memory cells and/or logic circuits. The semiconductor device **200** can include active components, such as metal-oxide-semiconductor field effect transistors (MOSFETs), complementary metal-oxide-semiconductor transistors (CMOSs), high voltage transistors, and/or high frequency transistors; other suitable components; and/or combinations thereof. The semiconductor device **200** may additionally include passive components such as resistors, capacitors, inductors, and/or fuses. It is understood that additional steps can be provided before, during, and after the method **100**, and some of the steps described below can be replaced or eliminated, for additional embodiments of the method. It is further understood that additional features can be added in the semiconductor device **200**, and some of the features described below can be replaced or eliminated, for additional embodiments of the semiconductor device **200**.

Referring to FIGS. 1 and 2, the method **100** begins at block **102** wherein a substrate **210** is provided. In the present embodiment, the substrate **210** is a semiconductor substrate including silicon. Alternatively, the substrate **210** includes an elementary semiconductor including germanium in crystal; a

compound semiconductor including silicon carbide, gallium arsenic, gallium phosphide, indium phosphide, indium arsenide, and/or indium antimonide; an alloy semiconductor including SiGe, GaAsP, AlInAs, AlGaAs, GaInAs, GaInP, and/or GaInAsP; or combinations thereof. In embodiments where the substrate **210** is an alloy semiconductor, the alloy semiconductor substrate could have a gradient SiGe feature in which the Si and Ge composition change from one ratio at one location to another ratio at another location of the gradient SiGe feature. The alloy SiGe could be formed over a silicon substrate, and/or the SiGe substrate may be strained. In yet another alternative, the semiconductor substrate is a semiconductor on insulator (SOI).

The substrate **210** includes various doped regions depending on design requirements as known in the art (e.g., p-type wells or n-type wells). The doped regions are doped with p-type dopants, such as boron or BF₂, and/or n-type dopants, such as phosphorus or arsenic. The doped regions may be formed directly on the substrate **210**, in a P-well structure, in a N-well structure, in a dual-well structure, or using a raised structure. In the present embodiment, the semiconductor device **200** is a CMOS device, and thus, the semiconductor substrate **210** includes various active regions, such as a region configured for an N-type metal-oxide-semiconductor transistor (referred to as an NMOS) and a region configured for a P-type metal-oxide-semiconductor transistor (referred to as a PMOS). It is understood that the semiconductor device **200** may be formed by CMOS technology processing, and thus some processes are not described in detail herein.

An exemplary isolation region **212** is formed on the substrate **210** to define and isolate various active regions of the substrate **210**, and in the present embodiment, to isolate the NMOS and PMOS device regions. The isolation region **212** utilizes isolation technology, such as shallow trench isolation (STI) or local oxidation of silicon (LOCOS), to define and electrically isolate the various regions. In the present embodiment, the isolation region **212** includes a STI. The isolation region **212** comprises silicon oxide, silicon nitride, silicon oxynitride, other suitable materials, or combinations thereof. The isolation region **212** is formed by any suitable process. As one example, the formation of an STI includes a photolithography process, etching a trench in the substrate (for example, by using a dry etching and/or wet etching), and filling the trench (for example, by using a chemical vapor deposition process) with one or more dielectric materials. In some examples, the filled trench may have a multi-layer structure, such as a thermal oxide liner layer filled with silicon nitride and/or silicon oxide. Then, a polishing process, such as chemical mechanical polishing (CMP) process, can be applied to remove the excessive dielectric materials above the top surface of the substrate, and produce a globally planarized surface.

The substrate **210** includes a gate structure disposed thereover, and in the present embodiment, includes gate structure **220** and gate structure **221** disposed thereover. In the present embodiment, the gate structures **220**, **221** include a gate dielectric layer **222**, a gate layer **224** (also referred to as a gate electrode), a hard mask layer **226**, and spacers **228**. The gate dielectric layer **222**, gate layer **224**, and hard mask layer **226** form gate stacks for the gate structures **220**, **221**. The gate stacks can include additional layers, including interfacial layers, high-k dielectric layers, capping layers, diffusion/barrier layers, conductive layers, other suitable layers, and/or combinations thereof.

The gate structures **220**, **221** are formed by deposition, photolithography patterning, and/or etching processes. The deposition processes include chemical vapor deposition

(CVD), physical vapor deposition (PVD), atomic layer deposition (ALD), high density plasma CVD (HDPCVD), metal organic CVD (MOCVD), remote plasma CVD (RPCVD), plasma enhanced CVD (PECVD), plating, other suitable deposition methods, and/or combinations thereof. The photolithography patterning processes include photoresist coating (e.g., spin-on coating), soft baking, mask aligning, exposure, post-exposure baking, developing the photoresist, rinsing, drying (e.g., hard baking), other suitable processes, and/or combinations thereof. Alternatively, the photolithography exposing process is implemented or replaced by other proper methods, such as maskless photolithography, electron-beam writing, or ion-beam writing. The etching processes include dry etching, wet etching, and/or other etching methods. It is understood that the gate structures **220**, **221** may be formed simultaneously, utilizing the same processing steps and processing materials; independently of one another, utilizing varying processing steps and processing materials; or using a combination of simultaneous and independent processing steps and processing materials.

The gate dielectric layer **222** is formed over the substrate **210** and includes a dielectric material, such as silicon oxide, silicon oxynitride, silicon nitride, a high-k dielectric material layer, other suitable dielectric materials, and/or combinations thereof. Exemplary high-k dielectric materials include HfO₂, HfSiO, HfSiON, HfTaO, HfTiO, HfZrO, other suitable high-k dielectric materials, and/or combinations thereof. The gate dielectric layer may include a multilayer structure. For example, the gate dielectric layer **222** could include an interfacial layer, and a high-k dielectric material layer formed on the interfacial layer. The interfacial layer is a grown silicon oxide layer formed by a thermal process or atomic layer deposition (ALD) process.

The gate layer **224** is formed over the gate dielectric layer **222**. In the present embodiment, the gate layer **224** is a polycrystalline silicon (or polysilicon) layer. The polysilicon layer may be doped for proper conductivity. Alternatively, the polysilicon is not necessarily doped if a dummy gate is to be formed and is replaced in a subsequent gate replacement process. Alternatively, the gate layer **224** could include a conductive layer having a proper work function, therefore, the gate layer **224** can also be referred to as a work function layer. The work function layer comprises any suitable material, such that the layer can be tuned to have a proper work function for enhanced performance of the associated device. For example, if a P-type work function metal (P-metal) for a PMOS device is desired, TiN or TaN may be used. On the other hand, if an N-type work function metal (N-metal) for NMOS devices is desired, Ta, TiAl, TiAlN, or TaCN, may be used. The work function layer could include doped conducting oxide materials. The gate layer **224** could include other conductive materials, such as aluminum, copper, tungsten, metal alloys, metal silicide, other suitable materials, and/or combinations thereof. For example, where the gate layer **224** includes a work function layer, another conductive layer can be formed over the work function layer.

The hard mask layer **226** is formed over the gate layer **224**. The hard mask layer includes silicon nitride, silicon oxynitride, silicon carbide, and/or other suitable dielectric materials. Alternatively, the hard mask layer **226** could include spin-on glass (SOG), fluorinated silica glass (FSG), carbon doped silicon oxide (e.g., SiCOH), Black Diamond® (Applied Materials of Santa Clara, Calif.), Xerogel, Aerogel, amorphous fluorinated carbon, Parylene, BCB (bis-benzocyclobutenes), Flare, SiLK (Dow Chemical, Midland, Mich.), polyimide, TEOS formed oxide, plasma enhanced oxide (PE

oxide), high aspect ratio deposition process (HARP) formed oxide, other suitable low-k dielectric materials, and/or combinations thereof.

In the present embodiment, the gate structures **220**, **221** include the spacers **228** (also referred to as offset spacers or dummy spacers). The offset spacers **228** are positioned on each side of the gate stacks (i.e., gate dielectric layer **222**, gate layer **224**, and hard mask layer **226**) of the gate structures **220**, **221** (e.g., along the sidewalls of the gate dielectric layer **222**/gate layer **224**/hard mask layer **226**). The offset spacers **228** include silicon nitride, or alternatively, other suitable dielectric materials, such as silicon oxide, silicon carbide, silicon oxynitride, and/or combinations thereof. In an example, the offset spacers **228** are formed by blanket depositing a dielectric layer over the semiconductor device **200**, and then, anisotropically etching to remove the dielectric layer to form offset spacers **228** as illustrated in FIG. 2.

Referring to FIGS. 1 and 3, at block **104**, an epitaxial layer is formed on the substrate. In the present embodiment, an epitaxial (epi) process, such as a selective epitaxy growth (SEG), is performed to grow epitaxial layer **230** and epitaxial layer **232** on exposed portions of the substrate **210**. The epitaxial layer **230** is formed in a source and drain region of the substrate **210**, interposed by the gate structure **220**, and the epitaxial layer **232** is formed in another source and drain region of the substrate **210**, interposed by the gate structure **221**. As shown in FIG. 3, the epitaxial layer **230**, **232** are adjacent to the spacers **228**, and specifically, the epitaxial layers **230**, **232** are aligned with an edge of the spacers **228**. Alternatively, the epitaxial process could include CVD deposition techniques (e.g., vapor-phase epitaxy (VPE) and/or ultra-high vacuum CVD (UHV-CVD)), molecular beam epitaxy, and/or other suitable processes. The epitaxial process may use gaseous and/or liquid precursors, which can interact with the composition of the substrate **210**. Prior to growing the epitaxial layers **230** and **232**, an etching process can be performed to form a recess/trench in the substrate **210**, in which the epitaxial layers are then grown.

In the present embodiment, the epitaxial layers **230**, **232** essentially form raised source and drain features of the source and drain regions of the substrate **210**. The epitaxial layers **230**, **232** comprise a suitable semiconductor material to induce a strained effect and/or other device performance enhancement effect. Exemplary semiconductor materials include silicon, silicon germanium, other suitable materials, or combinations thereof. In the present embodiment, the region of the substrate **210** that includes gate structure **220** is configured as an NMOS device, and the region of the substrate **210** that includes the gate structure **221** is configured as a PMOS device. Accordingly, epitaxial layer **230** includes a Si epi material, and epitaxial layer **232** includes a SiGe epi material. The epitaxial layer **230** and/or epitaxial layer **232** can be in-situ doped or undoped during the epitaxial growth. The epitaxial layers **230**, **232** can be doped with a phosphorous implant species, a carbon implant species, other suitable implant species, and/or combinations thereof. For example, in the present embodiment, the epitaxial layer **230** is doped with phosphorous (forming Si:P regions). When the epitaxial layer **230** and/or epitaxial layer **232** is undoped, it is understood that the undoped layer may be doped subsequently.

Referring to FIGS. 1 and 4, at block **106**, a heavily doped source/drain (HDD) feature is formed on the substrate. In the present embodiment, prior to forming the HDD features, dummy spacers **234** are formed by a suitable process. The dummy spacers **234** are positioned on each side of the offset spacers **228** of gate structures **220**, **221**. In the present embodiment, the dummy spacers **234** are similar to offset

spacers **228**. The dummy spacers **234** comprise a dielectric material, such as silicon nitride, silicon oxide, silicon carbide, silicon oxynitride, other suitable materials, and/or combinations thereof. In an example, the dummy spacers **234** are formed by blanket depositing a dielectric layer over the semiconductor device **200**, and then, anisotropically etching to remove the dielectric layer to leave dummy spacers **234**. Alternatively, the dummy spacers **234** are different than the offset spacers **228**, for example, formed of a different material and/or different process.

After forming the dummy spacers **234**, heavily doped source/drain features **236**, **238** are formed on the substrate **210**. More specifically, the HDD features are formed in the source and drain region of the substrate **210**. In the present embodiment, HDD features **236** are formed in the source and drain region of the substrate **210** interposed by the gate structure **220** (including in a portion of the epitaxial layer **230**), in the region configured for an NMOS device; and HDD features **238** are formed in the source and drain region of the substrate **210** interposed by the gate structure **221** (including in a portion of the epitaxial layer **232**), in the region configured for a PMOS device. The HDD features **236**, **238** are formed adjacent the spacers **234**. In the present embodiment, the HDD features **236**, **238** are aligned with an edge of the spacers **234**, and as illustrated in FIG. 4, spaced a distance away from the spacers **228**. The PMOS device region can be protected during formation of the HDD source/drain features **236** in the NMOS region, and vice versa. For example, a photoresist layer or patterned mask layer may be deposited and patterned over the PMOS device region during formation of the HDD features **236** in the NMOS region, and a photoresist layer or patterned mask layer can be deposited and patterned over the NMOS device region during formation of the HDD features **238** in the PMOS region.

The HDD features **236** and **238** are formed by an ion implantation process, diffusion process, and/or other suitable processes. The doping species depends on the type of device being fabricated, such as an NMOS or PMOS device. For example, since the region including gate structure **220** is configured for an NMOS device region, the HDD features **236** are doped with n-type dopants, such as phosphorus or arsenic; and since the region including the gate structure **221** is configured for a PMOS device region, the HDD features **238** are doped with p-type dopants, such as boron or BF_2 . In this situation, the HDD features **236** and **238** are formed separately by different ion implantation procedures and using different dopants. The HDD features **236**, **238** may comprise various doping profiles. In the present embodiment, the HDD features **236**, **238** are self-aligned with the dummy spacers **234**. An annealing process, which includes rapid thermal annealing (RTA) and/or laser annealing processes, can subsequently be performed to activate the HDD features **236**, **238**. The dummy spacers **234** are then removed. Alternatively, the dummy spacers **234** could be removed before the annealing process.

Referring to FIGS. 1 and 5, at block **108**, a lightly doped source/drain (LDD) feature is formed on the substrate. More specifically, the LDD features are formed in the source and drain region of the substrate **210**. In the present embodiment, LDD features **240** are formed in the source and drain region interposed by the gate structure **220** (including in a portion of the epitaxial layer **230**), in the region configured for an NMOS device; and LDD features **242** are formed in the source and drain region interposed by the gate structure **221** (including in a portion of the epitaxial layer **232**), in the region configured for a PMOS device. As shown in FIG. 4, the LDD features **240**, **242** are adjacent to the spacers **228**. In the

present embodiment, the LDD features **240**, **242** extend under the spacers **228**. Alternatively, the LDD features could be aligned with the edge of spacers **228**, similar to the epitaxial layers **230**, **232**. The PMOS device region can be protected during formation of the LDD features in the NMOS region, and vice versa. For example, a photoresist layer or patterned mask layer may be deposited and patterned over the PMOS device region during formation of the LDD features **240** in the NMOS region, and a photoresist layer or patterned mask layer can be deposited and patterned over the NMOS device region during formation of the LDD features **242** in the PMOS region.

The LDD features **240** and **242** are formed by an ion implantation process, diffusion process, and/or other suitable processes. In the present embodiment, a tilt-angle ion implantation process is implemented to form the LDD features **240**, **242**. The tilt-angle ion implantation process implements an ion beam with an angle to a direction perpendicular to the substrate **210**. The large-angle tilted ion implantation is implemented with a suitable tilt angle tuned to form the LDD features **240**, **242**. Because the method **100** forms the LDD features after forming the epitaxial layers **230**, **232** in the S/D regions of the substrate **210**, a maximum tilt-angle can be increased, while still avoiding shadowing effects caused by a height of the gate stack, particularly the hard mask layer **226**. For example, in the present embodiment, a tilt-angle utilized can be greater than 20°, such as approximately 30°. This occurs because a thickness/height of the gate stack, particularly hard mask layer **226**, is reduced by earlier processing (for example, by the epitaxial growth process and/or HDD feature formation process)(not shown in FIGS. 2-5), alleviating shadowing effects caused when the hard mask layer **226** is too high.

Further, conventional techniques, which form LDD features prior to the epitaxial layers, exhibit diffusion of LDD dopants during subsequent thermal processing, such as the epi growth processes. This limits a thermal budget for forming the epitaxial layers, reducing an ability to achieve target thicknesses for the epitaxial layers. In the present embodiment, which implements forming LDD features after the epi growth process, it has been observed that target thicknesses for the epitaxial layers can be better achieved since the epi growth processes are not limited by out-diffusion of dopants in the LDD features. This provides improved quality epi layers. Even further, due to the decreased out-diffusion of the LDD dopants, improved overall device performance has been observed, including improved ultra-shallow junction formation and improved short channel effects. It is understood that different embodiments may have different advantages, and that no particular advantage is necessarily required of any embodiment.

The doping species depends on the type of device being fabricated, such as an NMOS or PMOS device. For example, since the region including gate structure **220** is configured for an NMOS device region, the LDD features **240** are doped with n-type dopants, such as phosphorus or arsenic; and since the region including gate structure **221** is configured for a PMOS device region, the LDD features **242** are doped with p-type dopants, such as boron or BF₂. In this situation, the LDD features **240** and **242** are formed separately by different ion implantation procedures and using different dopants. The LDD features **240**, **242** may comprise various doping profiles. An annealing process, which includes rapid thermal annealing (RTA) and/or laser annealing processes, can subsequently be performed to activate the LDD features **240**, **242**. In the present embodiment, the exemplary method **100** forms the HDD features **236**, **238** prior to the LDD features **240**, **242**.

Alternatively, the HDD features **236**, **238** could be formed after the LDD features **240**, **242**. It should be noted that because the LDD features **240**, **242** are formed after the epitaxial layer **230**, **232**, the semiconductor device **100** includes epitaxial layers **230**, **232** and LDD features **240**, **242** adjacent to the spacers **228** and aligned with an edge of the spacers **228**, while the HDD features **236**, **238** are spaced a distance away from the edge of the spacers **228**.

Referring to FIG. 1, at block **110**, fabrication of the semiconductor device **200** continues to complete fabrication as briefly discussed below. The semiconductor device **200** may undergo further CMOS or MOS technology processing to form various features known in the art. For example, the method **100** may proceed to form main spacers, similar to offset spacers **228** and/or dummy spacers **234**. In an embodiment, the offset spacers **228** are removed prior to forming the main spacers. Further, contact features, such as silicide regions, may also be formed. The contact features may be coupled to the source and drain regions of the substrate **210** (e.g., epitaxial layer regions **230**, **232**). The contact features comprise silicide materials, such as nickel silicide (NiSi), nickel-platinum silicide (NiPtSi), nickel-platinum-germanium silicide (NiPtGeSi), nickel-germanium silicide (NiGeSi), ytterbium silicide (YbSi), platinum silicide (PtSi), iridium silicide (IrSi), erbium silicide (ErSi), cobalt silicide (CoSi), other suitable conductive materials, and/or combinations thereof. The contact features can be formed by a process that includes depositing a metal layer, annealing the metal layer such that the metal layer is able to react with silicon to form silicide, and then removing the non-reacted metal layer. An inter-level dielectric (ILD) layer can further be formed on the substrate **210** and a chemical mechanical polishing (CMP) process is further applied to the substrate to planarize the substrate. Further, a contact etch stop layer (CESL) may be formed on top of the gate structures **220**, **221** before forming the ILD layer.

In an embodiment, the gate layer/electrode **224** remains polysilicon in the final device. In another embodiment, a gate replacement process (or gate last process) is performed, wherein the polysilicon gate layer **224** is replaced with a metal gate. For example, a metal gate may replace the gate layer (i.e., polysilicon gate layer) of the gate structures **220**, **221**. The metal gate in the gate structure **220** could have a different work function than the metal gate in the gate structure **221**. The metal gates include liner layers, work function layers, conductive layers, metal gate layers, fill layers, other suitable layers, and/or combinations thereof. The metal gate layers include any suitable material, such as aluminum, copper, tungsten, titanium, tantalum, tantalum aluminum, titanium nitride, tantalum nitride, nickel silicide, cobalt silicide, silver, TaC, TaSiN, TaCN, TiAl, TiAlN, WN, metal alloys, other suitable materials, and/or combinations thereof. In a gate last process, the CMP process on the ILD layer is continued to expose the poly gate layer **224** (and hard mask layer **226**) of the gate structures **220**, **221**, and an etching process is performed to remove the gate layer **224** (and hard mask layer **226**) thereby forming trenches. The trenches are filled with a proper work function metal (e.g., p-type work function metal and n-type work function metal) for the PMOS devices and the NMOS devices.

Subsequent processing may form various contacts/vias/lines and multilayer interconnect features (e.g., metal layers and interlayer dielectrics) on the substrate **210**, configured to connect the various features or structures of the semiconductor device **200**. The additional features may provide electrical interconnection to the device. For example, a multilayer interconnection includes vertical interconnects, such as conven-

tional vias or contacts, and horizontal interconnects, such as metal lines. The various interconnection features may implement various conductive materials including copper, tungsten, and/or silicide. In one example, a damascene and/or dual damascene process is used to form a copper related multilayer interconnection structure.

The foregoing outlines features of several embodiments so that those skilled in the art may better understand the aspects of the present disclosure. Those skilled in the art should appreciate that they may readily use the present disclosure as a basis for designing or modifying other processes and structures for carrying out the same purposes and/or achieving the same advantages of the embodiments introduced herein. Those skilled in the art should also realize that such equivalent constructions do not depart from the spirit and scope of the present disclosure, and that they may make various changes, substitutions, and alterations herein without departing from the spirit and scope of the present disclosure.

What is claimed is:

1. A method comprising:
 - providing a substrate;
 - forming a gate structure over the substrate;
 - forming inner spacers on sidewalls of the gate structure;
 - forming an epitaxial layer in a source and drain region of the substrate that is interposed by the gate structure, wherein the epitaxial layer physically contacts the inner spacers on the sidewalls of the gate structure;
 - after forming the epitaxial layer, forming outer spacers on the inner spacers and the epitaxial layer such that the outer spacers physically contact the inner spacers and the epitaxial layer;
 - after forming the outer spacers, forming a heavily doped source and drain (HDD) feature in the source and drain region; and
 - after forming the HDD feature, forming a lightly doped source and drain (LDD) feature in the source and drain region, wherein after forming the LDD feature the epitaxial layer physically contacts the inner spacers on the sidewalls of the gate structure.
2. The method of claim 1 wherein forming the LDD feature in the source and drain region includes performing a tilt-angle ion implantation process.
3. The method of claim 2 wherein performing the tilt-angle ion implantation process includes utilizing a tilt-angle greater than about 20°.
4. The method of claim 1 wherein forming the epitaxial layer in the source and drain region interposed by the gate structure includes performing a silicon or silicon germanium epitaxial growth process.
5. The method of claim 4 further comprising doping the epitaxial layer with a carbon or phosphorous implant species.
6. The method of claim 1 wherein forming the gate structure includes forming a gate stack that includes a polysilicon layer and a hard mask layer over the polysilicon layer.
7. The method of claim 1, further comprising:
 - removing the outer spacer prior to forming the LDD feature in the source and drain region; and
 - after removing the outer spacer, performing an annealing process on the HDD feature prior to forming the LDD feature in the source and drain region.
8. A method comprising:
 - forming a first gate structure and a second gate structure over a substrate;
 - forming an inner spacer on a sidewall of the first gate structure;

forming an epitaxial layer of a first material in a source and drain region of the substrate that is interposed by the first gate structure,

wherein the epitaxial layer physically contacts the inner spacer on the sidewall of the first gate structure;

forming an epitaxial layer of a second material in another source and drain region of the substrate that is interposed by the second gate structure; and

after forming the epitaxial layer of the first material in the source and drain region of the substrate that is interposed by the first gate structure, forming an outer spacer on the inner spacer and the epitaxial layer of the first material such that the outer spacer physically contacts the inner spacer and the epitaxial layer of the first material;

after forming the epitaxial layer, forming heavily doped source and drain (HDD) features in the source and drain region and the another source drain region of the substrate; and

after forming the HDD feature, forming lightly doped source and drain (LDD) features in the source and drain region and the another source drain region of the substrate, wherein after forming the LDD features in the source and drain region the epitaxial layer physically contacts the inner spacer on the sidewall of the first gate structure.

9. The method of claim 8 wherein forming the epitaxial layer of the first material includes epitaxially growing a silicon layer, and forming the epitaxial layer of the second material includes epitaxially growing a silicon germanium layer.

10. The method of claim 9 further comprising implanting the silicon layer with a phosphorous or carbon implant species.

11. The method of claim 8 wherein forming the LDD features in the source and drain region includes performing a tilt-angle ion implantation process.

12. The method of claim 8 wherein forming the LDD features in the source and drain region interposed by the first gate structure includes performing an implantation process with a first implant species, and forming the LDD features in the another source and drain region interposed by the second gate structure includes performing an implantation process with a second implant species, the second implant species being different than the first implant species.

13. The method of claim 8 further comprising performing a gate replacement process that includes:

- replacing the first gate structure with a gate layer having a first work function; and

- replacing the second gate structure with a gate layer having a second work function.

14. The method of claim 8, wherein the epitaxial layer of the first material extends to a first depth within the substrate and the epitaxial layer of the second material extends to a second depth within the substrate, the second depth being different than the first depth.

15. The method of claim 8, wherein forming the HDD features in the source and drain region interposed by the first gate structure includes forming the HDD features to a first depth within the source and drain region interposed by the first gate structure, and

- wherein forming the HDD features in the another source and drain region interposed by the second gate structure includes forming the HDD features to a second depth within the source and drain region interposed by the second gate structure, the second depth being different than the first depth.

16. A method comprising:

- providing a substrate;

forming a gate structure over the substrate, the gate structure including a first sidewall spacer;
forming an epitaxial layer in a source and drain region of the substrate that is interposed by the gate structure, wherein the epitaxial layer physically contacts the first sidewall spacer of the gate structure;
after forming the epitaxial layer, forming a second sidewall spacer on the first sidewall spacer such that the second sidewall spacer physically contacts the first sidewall spacer and the epitaxial layer;
after forming the second sidewall spacer, forming a heavily doped source and drain (HDD) feature in the source and drain region; and
after forming the HDD feature in the source and drain region, forming a lightly doped source and drain (LDD) feature in the source and drain region, wherein after forming the LDD feature the epitaxial layer physically contacts the first sidewall spacer of the gate structure.

17. The method of claim 16, further comprising removing the second sidewall spacer prior to forming the LDD features.

18. The method of claim 16, wherein the HDD feature in the source and drain region has an edge that is aligned with an outer edge of the second sidewall spacer.

19. The method of claim 16, wherein the LDD feature has an edge that is aligned with an inner edge of the first spacer.

20. The method of claim 16, wherein forming the LDD feature in the source and drain region includes performing a tilt-angle ion implantation process.

* * * * *

30