

VII. GROUND 1: Ganz and Larrick in Combination with Roesse Renders Claims 1-16, 20, and 24-28 Obvious²

A. Overview and Motivation to Combine

~~75.~~As discussed in more detail below, Ganz teaches a wireless networking device that receives wireless data, processes that wireless data, and transmits

~~² Unless noted otherwise, all emphases in quotes and annotations to figures from prior art references are added.~~

wireless data. Ganz uses a wireless burstable communications repeater. (EX1005, Abstract.) Larrick similarly teaches a wireless networking device that contains an ~~ultra-wideband~~ultra- wideband transmitter and receiver, with data rates of at least 100 megabits per second and bandwidth between 100 and 500 MHz. (EX1002, ¶75.)

~~76.~~A POSITA would have been motivated to incorporate the teachings of Larrick to improve the Ganz system by allowing it to transmit and receive data using wider frequency bands and at higher data speeds. Ganz teaches a wireless repeater system for wirelessly receiving and transmitting data, and Larrick provides additional detail on how to use ultra-wide band frequency bandwidths and data speeds to wirelessly transfer data. The teachings of Ganz are

complementary to Larrick, and a POSITA would have recognized that Larrick's teachings could be easily implemented into Ganz without technical challenge. (EX1002, ¶76.)

² Unless noted otherwise, all emphases in quotes and annotations to figures from prior art references are added.

~~77.~~ Ganz addresses wireless burstable communications repeaters for creating network infrastructures while Larrick discloses an ultra-wideband (UWB) transmitter and receiver system with controllable spectral characteristics. Ganz, which discloses efficient spectrum utilization in a shared wireless environment, would benefit from Larrick's waveform-adaptive UWB transmitter which provides "well defined and controllable spectral characteristics." (EX1007, Abstract.) These technologies address different aspects of wireless communication that could

naturally work together including Larrick's use of wider frequency bandwidths than those disclosed in Ganz. (EX1002, ¶77.)

~~those disclosed in Ganz.~~

~~78.~~ The "wireless high speed data communication system" of Ganz (EX1005, Abstract), would benefit from Larrick's UWB technology which enables

even faster data speeds such as “extremely high pulse repetition frequencies (PRFs) and data rates in the hundreds of megabits per second” (EX1007, Abstract) ([EX1002, ¶78.](#))

~~79.~~ Larrick’s UWB technology, which offers waveform adaptation that could improve signal propagation in challenging environments, would be beneficial to Ganz which addresses communication problems where “extended coverage areas are desired and line-of-sight conditions do not exist.” (EX1005, 1:62-63.) Like Ganz, Larrick arises in the field wireless communication networks and is addressed to increasing transmitting information wirelessly. (EX1007, Abstract.) ([EX1002, ¶79.](#))

Enhanced Modulation Techniques

~~80.~~ The combination would particularly benefit from the complementary modulation approaches described in both patents. Larrick introduces sophisticated UWB signal generation methods that would significantly enhance the Ganz system:

- Larrick’s “waveform-adaptive” approach provides precise control over UWB signal characteristics through an “impulse-gated oscillator” that allows “precise control of radiated frequency” governed by “the choice of oscillator which has a known stable frequency.” (EX1007, 5:62-65.)
- Larrick supports advanced modulation including phase modulation where

“oscillator phase may also be controlled to generate an additional phase modulation.” (EX1007, 5:67-6:1.)

- Larrick enables “frequency agility on a pulse-by-pulse basis allowing frequency hopping if desired” (EX1007, Abstract), which would enhance the frequency hopping capabilities already present in Ganz’ system where “three different hopping sequence sets are established with twenty-six (26) hopping sequences per set.” (EX1005, 7:21-23.)
- Larrick describes a “time-gated oscillator” approach using high-speed switches to create “a sub-nanosecond microwave burst” with controllable bandwidth. (EX1007, 15:1-9.) [\(EX1002, ¶80.\)](#)

~~81.~~ These advanced modulation capabilities would pair effectively with Ganz’ network protocols, particularly the “burstable packet multi access/collision avoidance (BPMA/CA) protocol” (EX1005, 5:16-17) that Ganz uses to improve network efficiency. [\(EX1002, ¶81.\)](#)

Multi-User Capability and Spectral Efficiency

~~82.~~ Ganz identifies inefficient spectrum utilization in conventional systems due to "polling" which leads to "time slots [going] unused when a polled radio has no data to transfer.” (EX1005, 1:58-60.) Combining this with Larrick’s ability to control “center frequency and bandwidth” (EX1007, 6:14-15) on a

“pulse-by-pulse

basis” (EX1007, 5:52) would create an advanced multiple access scheme

where:

- Different users could be assigned different UWB center frequencies, enhancing Ganz’ ability to support “multiple segments to be installed in a common geographical area without interfering with each other.” (EX1005, 8:17-18.)
- The network could dynamically allocate bandwidth based on user requirements, improving on Ganz’ goal of providing “high communication speeds” in a “multi-user (access) environment.” (EX1005, 2:41-42.)
- Larrick’s “well defined and controllable spectral characteristics” (EX1007, Abstract) would enhance Ganz’ ability to segment networks where “data bandwidth can be increased beyond 1.5 Mb/s for higher data transfer rate.” ~~(EX1005, 8:39-40.)~~

[\(EX1005, 8:39-40.\)](#) [\(EX1002, ¶82.\)](#)

Link Quality Assessment and Power Efficiency

~~83.~~ Ganz describes sophisticated link testing where “control packets” with “sequence numbers” allow the system to “know whether packets were lost either on the way to the destination, or on the way back to the source node” (EX1005, 12:28- 31). This capability would pair effectively with Larrick’s adaptable UWB parameters to create a system that could dynamically adjust transmission parameters based on link quality. [\(EX1002, ¶83.\)](#)

~~84.~~ Additionally, Larrick’s “gated power amplifier” with “the unique

feature of high power efficiency as the power amplifier is only turned on for

approximately the duration of the UWB pulse” (EX1007, 6:42-45) would be particularly valuable in Ganz’ repeater network, especially for remote installations. [\(EX1002, ¶84.\)](#)

Data Rate Advancement and Industry Trends

~~85.~~At the time of the ‘337 patent, a significant industry trend was toward higher data rates in wireless communication systems. Ganz’ system specifically aims to overcome the “reduction of throughput by a factor of two” that occurs in ~~half-duplex~~[half-duplex](#) systems (EX1005, 1:19-20) and discusses achieving “information throughput in each segment is preferably at least 1.5 Mb/s, equal to a full dedicated T-1 line rate.” (EX1005, 8:24-26.) However, Ganz acknowledges bandwidth limitations within specific frequency bands, noting that “with an 11-bit modulation sequence, a transmission is spread over a 20 MHz bandwidth.” (EX1005, 8:26-27). [\(EX1002,](#)

[¶85.\)](#)

~~86.~~Larrick directly addresses these limitations by providing technology that enables “data rates in the hundreds of megabits per second or more” (EX1007, Abstract) and explicitly states that prior UWB systems had limitations that prevented higher data rates. (*E.g.*, EX1007, 5:41-44.) Larrick’s UWB system operates with bandwidths substantially greater than those mentioned in Ganz, with examples showing bandwidths of “400 MHz” (EX1007, 10:63-64) and “over 2 GHz.” (EX1007, 15:41-42.) [\(EX1002, ¶86.\)](#)

~~87.~~These significant improvements in data rate capabilities – from Ganz’ 1.5 Mb/s to Larrick’s “hundreds of megabits per second” – represent precisely the

kind of technological advancement that would motivate a POSITA to combine these references. The substantially increased bandwidth of Larrick's UWB system (400 MHz and greater compared to Ganz' 20 MHz) would directly enable these higher data rates. [\(EX1002, ¶87.\)](#)

~~88.~~—The combination of Ganz and Larrick would have a reasonable expectation of success. Larrick provides technical details for its ultra-wideband transmitter and receivers, explaining how they can operate at higher bandwidths and data rates. It would have been well-within the skill of an ordinary artisan to implement Larrick's teachings into Ganz' repeater systems. [\(EX1002, ¶88.\)](#)

~~89.~~—In the analysis below, the combined prior art system will be referred to as ~~Ganz/Larrick.~~

Ganz/Larrick. (EX1002, ¶89.)

~~90.~~—Roese teaches various methods for locating the position of a wireless repeater using network information and using the location information within a network, such as to determine the location of user devices connected to the repeater. (EX1002,

¶90.)

~~91.~~—A POSITA would have been motivated to incorporate the teachings of Roese to improve the Ganz system (along with its combination with Larrick) because of the utility of location information. As Roese itself teaches, location information “may be used in any of a variety of ways to improve configuration accuracy, control, and security,” as well as “control or secure a device itself.” (EX1012, 2:23-28.)

Roese also teaches that “the device location can be used in any number of ways to enhance the operation of, and services provided by, the system,” for example, “anywhere user credentials are required, the location of a device can be required.” (*Id.*, 2:54-61.) Location information was also useful for network administrators to optimize coverage of wireless access points as well as perform location-aware handovers. For example, by knowing the location of itself and its neighbors as well as a user device, a wireless repeater/router could more optimally

hand off the user device to a neighboring wireless access point. In addition, users of user devices would have found location information to be beneficial, such as when using mapping or emergency services. The techniques of Roese would have been particularly useful

at the time of the '337 patent when user devices were unlikely to have GPS.
(EX1002, ¶91.)

~~92.~~A POSITA would have reasonably expected the combination to succeed. The methods described in Roesse used conventional wireless network technologies and Roesse provides significant detail on its implementation which was within the skill of an ordinary artisan. (EX1002, ¶92.)

B. Limitation-By-Limitation Analysis

1. Claim 1

a) 1[pre]: A broadband wireless repeater or relay, comprising:

~~93.~~Ganz's invention "relates generally to a radio communications repeater, and more particularly relates to a radio communications repeater system for ~~high-~~
high-speed ~~speed~~-data communication which enables multiple users to access a common geographically distributed radio channel. (EX1005, 1:7-12). Ganz further explains that "[t]he radio/data link element circuits" within its wireless burstable communications repeater (WBCR) "can incorporate an IEEE 802.11 specification, the disclosure of which is incorporated herein by reference, which calls for two different physical layer implementations: frequency hopping spread spectrum (FHSS) and direct sequence spread spectrum (DSSS)." (EX1005, 7:12-16.) (EX1002, ¶93.)

~~94.~~—Larrick discloses “[a] waveform-adaptive ultra-wideband (UWB) transmitter and noise-tracking UWB receiver for use in communications, object detection and radar applications.” Larrick also claims “[a] communication system utilizing an ultra-wideband (UWB) transmitter” (EX1007, 24:52-53) and “[a] method of communicating data by transmitting and detecting an ultra wideband UWB pulse.” (*id.*, 27:17-18). ([EX1002, ¶94.](#))

~~95.~~—Thus, as further discussed in the below limitations, Ganz/Larrick discloses a broadband wireless repeater or relay. ([EX1002, ¶95.](#))

b) 1[a]: at least one receiver or transceiver for signal or data reception from one or more devices;

~~96.~~—Ganz discloses a wireless burstable communications repeater (WBCR) that includes a first transceiver circuit 132 and a second transceiver circuit 140. (EX1005, 3:64-4:21.) A block diagram of a WBCR functional architecture is

illustrated in FIG. 2 including the first and second transceiver circuits. (EX1005, 3:64-4:21.) ([EX1002, ¶96.](#))

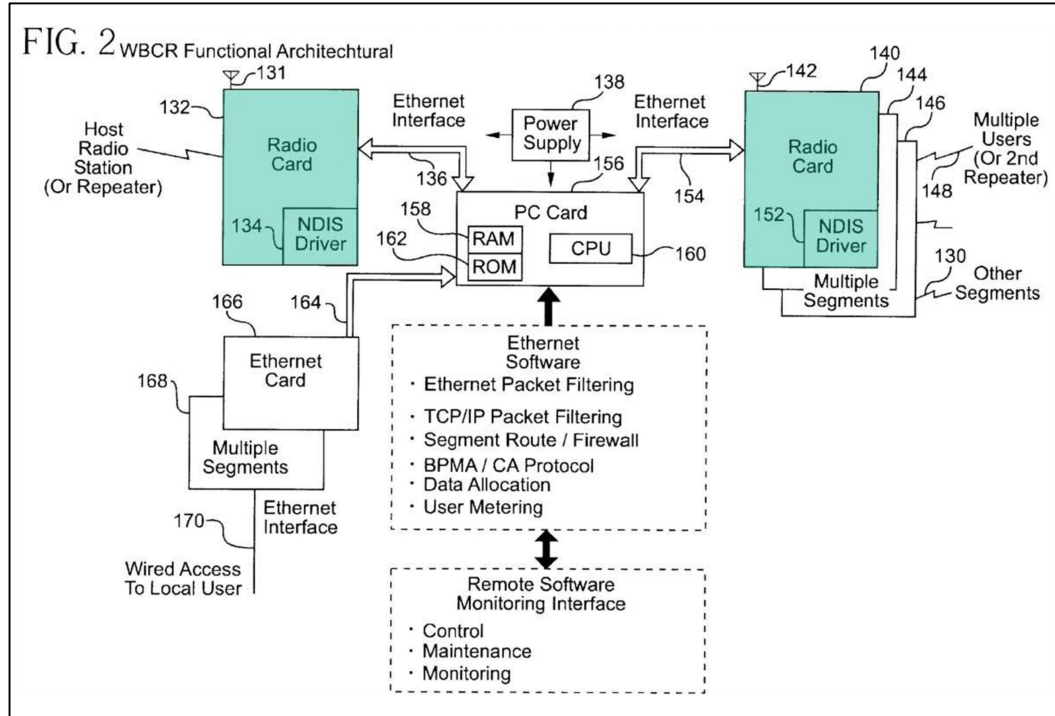

97. Ganz describes that “[t]he WBCR functions, such that the data packets coming from the user side, are *received* by the second radio transceiver circuit 140.” (EX1005, 4:22-24.) Further, the second radio transceiver circuit 140 “provides multiple radio frequency access to remotely distributed users and/or other WBCRs.” (EX1005, 4:9:12.) (EX1002, ¶97.)

98. Additionally, Ganz explains that the first radio transceiver circuit 132 “provides the radio frequency link to a host radio station and, optionally, to one or more repeaters.” (EX1005, 4:8-12.) During a full data stream transfer, data packets can be “*receiv[ed]*...from the host radio station” by the first radio transceiver circuit

132 before being “transmitted to the user” via the second radio

transceiver circuit

140. (EX1005, 4:30-35.) (EX1002, ¶98.)

~~99.~~ Thus, Ganz discloses at least one transceiver for signal or data reception from one or more devices. (EX1002, ¶99.)

c) **1[b]: at least one transmitter or transceiver for signal or data transmission to one or more devices,**

~~100.~~ As described above, Ganz discloses a wireless burstable communications repeater (WBCR) containing at least two transceivers shown in FIG. 2. (EX1005, 3:64-4:21.) (EX1002, ¶100.)

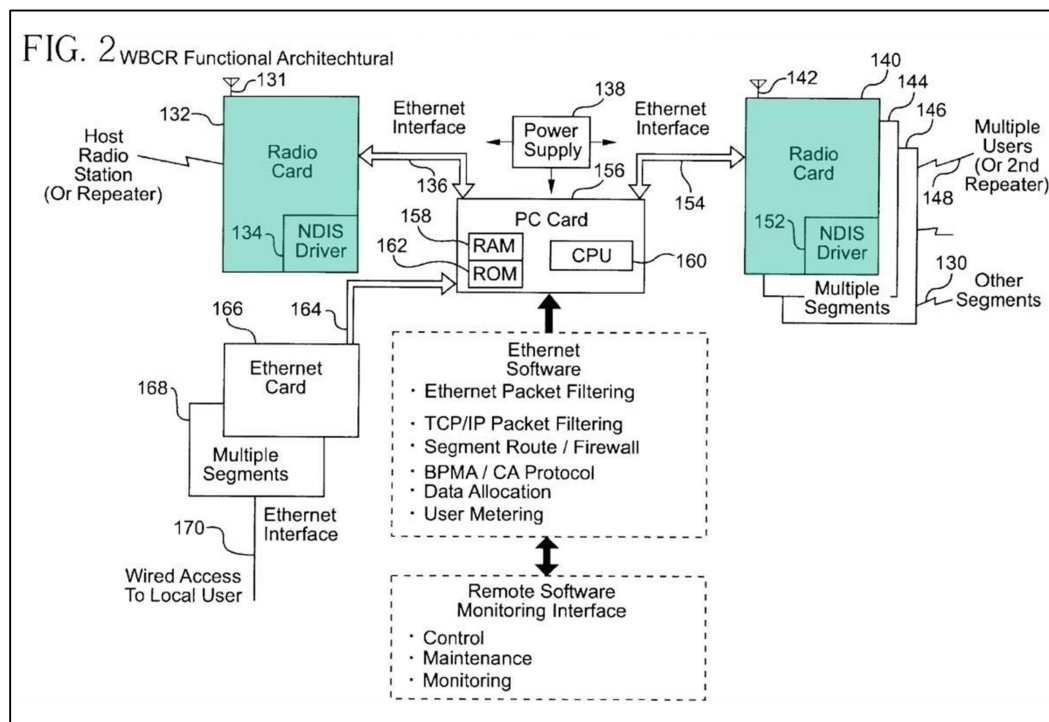

~~101.~~ Ganz explains that the first radio transceiver circuit 132 “provides the radio frequency link to a host radio station and, optionally, to one or more

repeaters.”

(EX1005, 4:8-12.) During a full data stream transfer, data packets can be “receiv[ed]...from the host radio station” by the first radio transceiver circuit 132

before being “*transmitted* to the user” via the second radio transceiver circuit 140.

(EX1005, 4:30-35.) [\(EX1002, ¶101.\)](#)

~~102.~~ Additionally, Ganz describes that “[t]he WBCR functions, such that the data packets coming from the user side, are received by the second radio transceiver circuit 140... before being *retransmitted* by the radio transceiver circuit” to the host radio station. (EX1005, 4:22-26.) Further, the second radio transceiver circuit 140 “provides multiple radio frequency access to remotely distributed users and/or other WBCRs.” (EX1005, 4:9:12.) [\(EX1002, ¶102.\)](#)

~~103.~~ Thus, Ganz discloses at least one transceiver for signal or data transmission from one or more devices. [\(EX1002, ¶103.\)](#)

d) 1[c]: wherein the transceiver for signal or data reception and the transceiver for signal or data transmission may be the same or different; and

~~104.~~ According to Ganz, “[t]he radio transceiver circuit 132, provides the radio frequency link to a host radio station and, optionally, to one or more repeaters. The second radio transceiver circuit 140, provides multiple radio

frequency access to remotely distributed users and/or other WBCRs.” (EX1005, 4:8-21.) Thus Ganz discloses multiple transceivers that may perform both signal or data transmission and reception, and thereby discloses wherein the transceiver for signal or data

reception and the transceiver for signal or data transmission may be different or the same. [\(EX1002, ¶104.\)](#)

- e) **1[d]: a controller that is configured or configurable for operation in one or more wireless networks, said controller communicating with said at least one receiver or transceiver for signal or data reception and said at least one transmitter or transceiver for signal or data transmission,**

~~105.~~Ganz discloses a wireless burstable communications repeater (WBCR) containing a “computer circuit 156” that “*performs the controlling functions* within the WBCR and includes the processor 160 (e.g., 486 CPU or equivalent), the RAM circuit 158 and the ROM circuit 162.” (EX1005, 4:15-21.) [\(EX1002, ¶105.\)](#)

FIG. 2 WBCR Functional Architectural

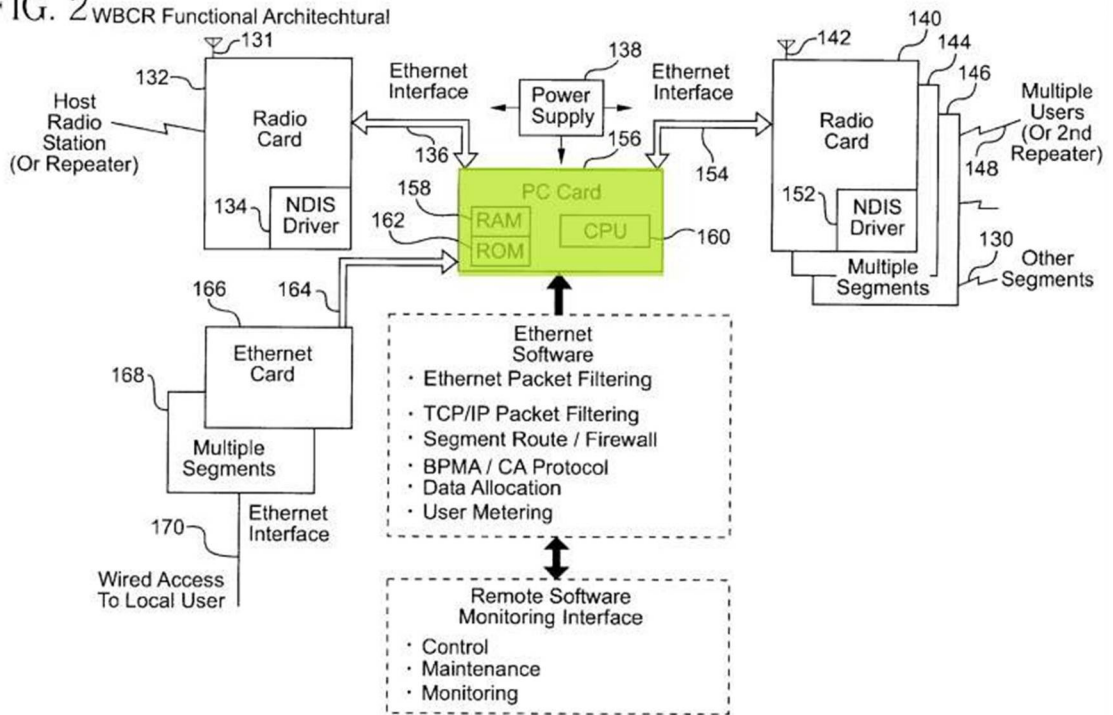

~~106.~~ As is evident in FIG. 2 above, the computer circuit communicates with each transceiver circuit 132 and 140. (EX1002, ¶106.)

f) 1[e]: wherein at least one of said receiver or ~~f~~ transceiver for signal or data reception and said transmitter or transceiver for signal or data transmission either or both transmit and receive at an instantaneous or overall occupied bandwidth of 100 MHz or more or have a data transmission rate of 100 Megabits per second or more,

~~107.~~ Ganz discloses a wireless burstable communications repeater (WBCR).

A block diagram of a WBCR functional architecture is illustrated in FIG. 2 including a radio transceiver circuit 132 and a second radio transceiver circuit 140. (EX1005, 3:64-4:21.) (EX1002, ¶107.)

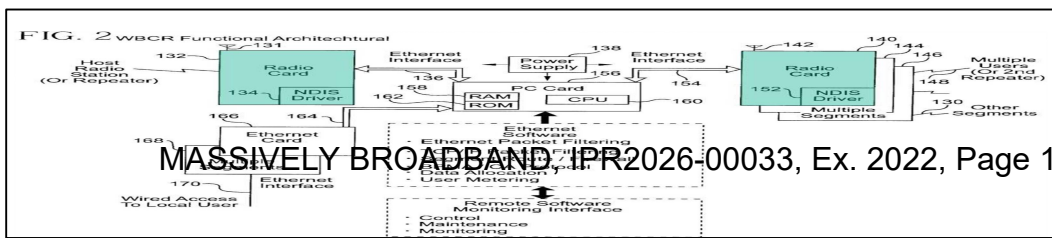

~~108.~~ Ganz does not expressly disclose that the transmitter is configured for transmitting and receiving at an instantaneous or overall occupied bandwidth of 100

MHz. However, Larrick discloses a transmitter using the claimed bandwidth and as

discussed above, a POSITA would have been motivated to combine Ganz and Larrick. (EX1002, ¶108.)

~~109.~~ Larrick “relates to the field of ultra-wideband communication systems. More particularly, [Larrick] relates to the controlled transmission and reception of ~~ultra-wideband~~ultra- wideband electromagnetic pulses.” (Ex. 1007, 1:21-24) Larrick discloses “UWB transmitters which generate UWB signals having controllable spectral characteristics.” (*Id.*, 9:21-23) “[U]nlike direct high-power impulse excitation of an antenna as in conventional UWB transmitters, low-level impulse excitation of bandpass filter 102 provides complete control over all aspects of the spectral emissions of the UWB transmitter. This is because the spectral emissions are determined exactly by the characteristics of bandpass filter 102, for instance by the center frequency, bandwidth, out of band rejection and skirt responses.” (*Id.*, 11:26-35.) (EX1002, ¶109.)

~~110.~~ In one described embodiment and as shown in FIG. 12A, “[a]n UWB transmitter using a low-level impulse generator and microwave bandpass filter was constructed which generated an L-band UWB signal at a center frequency of 1.5 GHz, *with a 3 dB bandwidth of 400 MHz.*” (EX1007, 10:61-64.) (EX1002,

¶110.)

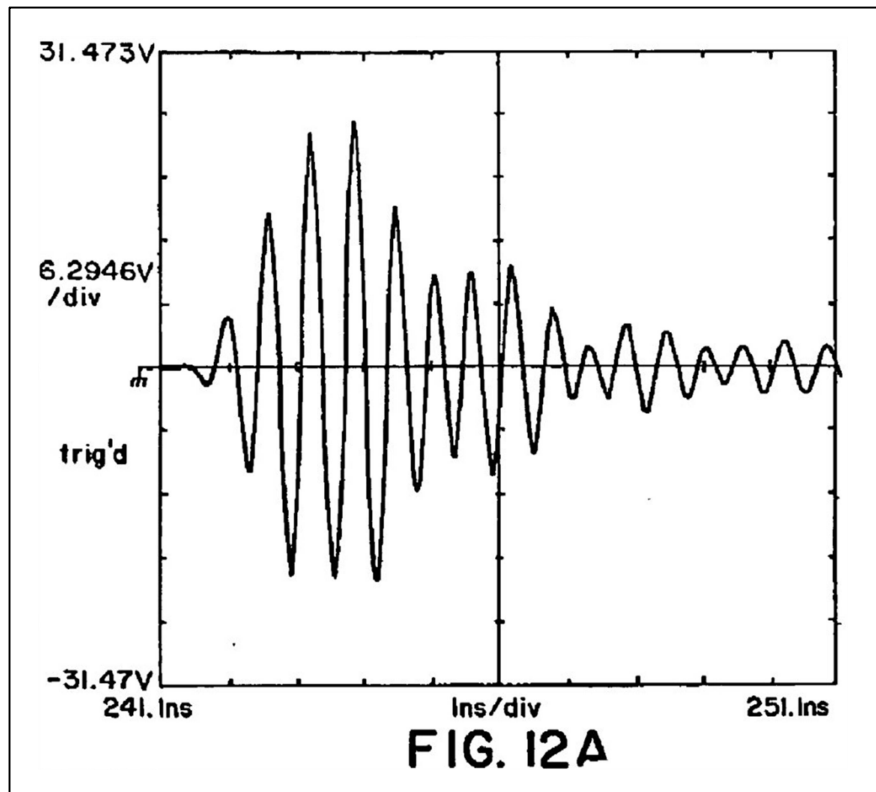

~~111.~~ FIG. 12B shows the frequency spectrum of the UWB signal shown in FIG. 12A. “The particular filters used were L-band bandpass filters, with a center frequency of 1.5 GHz, *a 1 dB bandwidth of 400 MHz, a 3 dB bandwidth of 500 MHz*, rejection at 1 GHz of greater than 30 dB down.” (*Id.*, 10:65-11:4.) [\(EX1002, ¶111.\)](#)

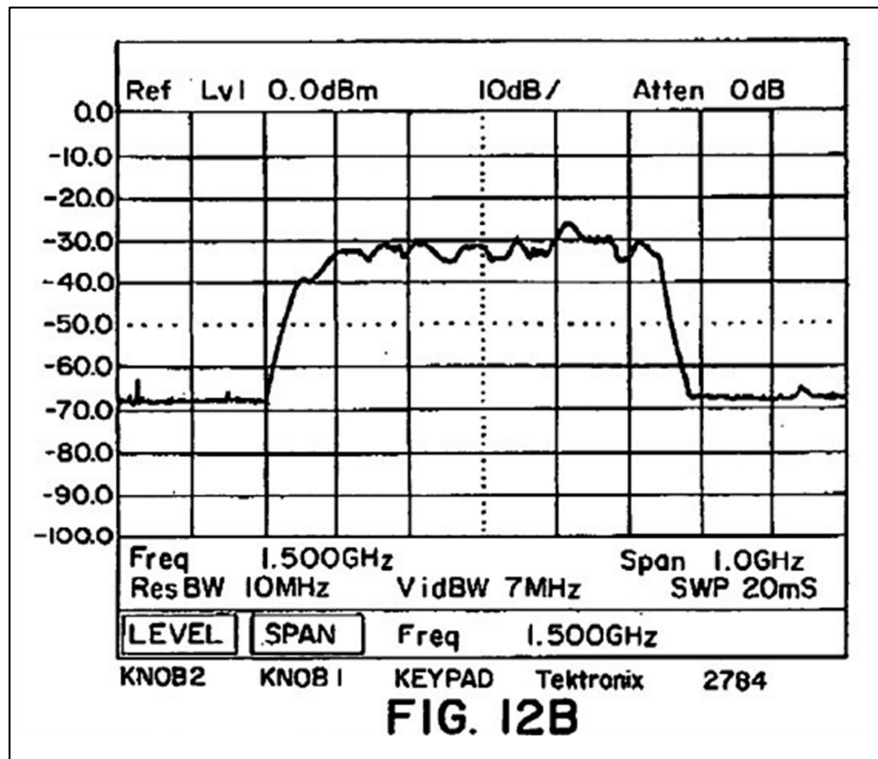

~~112.~~ FIG. 16 “a photograph of a circuit board of a transceiver utilizing the present invention” (*id.*; 9:7-8) “shows the UWB receiver imbedded in a full duplex, voice/data ultra wideband transceiver. The RF section of this particular unit (lower left hand side) is wideband from a few MHz to beyond 4 GHz. Tunnel diodes with adequate response characteristics to 26 GHz and beyond are currently available, and thus **the UWB receiver can readily accommodate a wide variety of center frequencies between a few MHz upwards toward 26 GHz.**” (*Id.*; 21:54-61) ([EX1002, ¶112.](#))

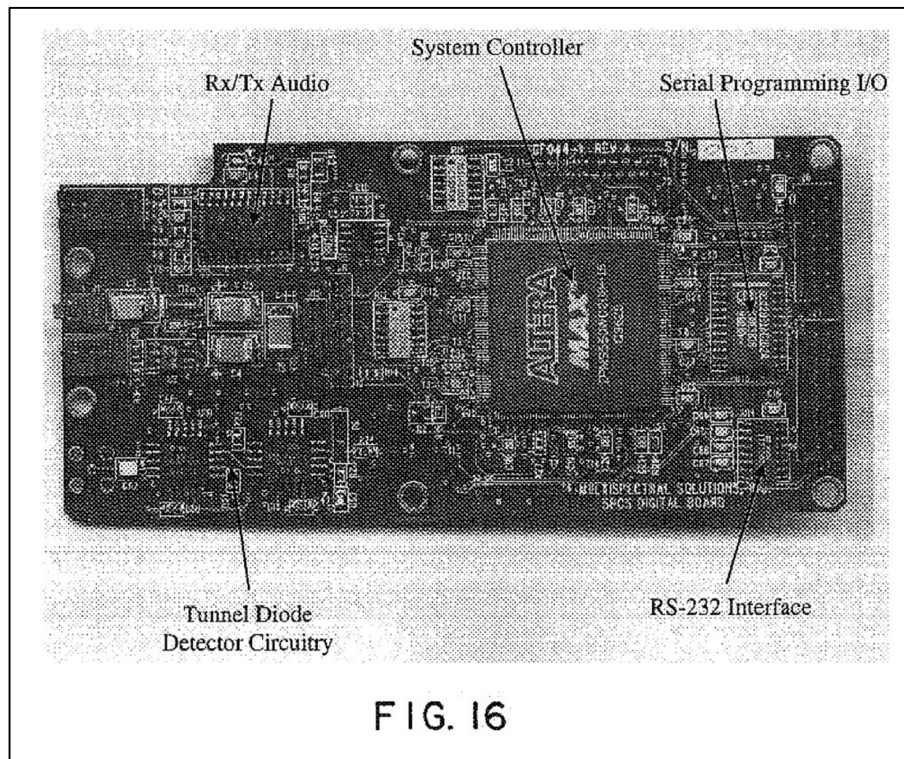

~~113.~~ A POSITA would have understood that the ultra-wideband transmitter on the same circuit board as the ultra-wideband receiver would be designed or calibrated to transmit transmissions to the ultra-wideband receiver of the transceiver. Larrick describes and shows the calibration of the receiver. (EX1007, FIG. 15 and 19:~~35-21~~35-21:12.) In the object detection applications described in Larrick, it would be advantageous if not required that the transmitter have the same frequency bandwidth as the receiver. Larrick discloses a transmitter with the claimed data rates and as discussed above, a POSITA would have been motivated to combine Ganz and Larrick. In particular, Larrick discloses that its ultra-wideband transmitter is capable of “data rates in the *hundreds of megabits*

per second or more, frequency agility on

a pulse-to-pulse basis allowing frequency hopping if desired, and extensibility from below HF to millimeter wave frequencies.” (EX1007, Abstract.) [\(EX1002, ¶113.\)](#)

- g) **1[f]: wherein said broadband wireless repeater or relay is connected or connectable to one or more network backbones for connecting said one or more wireless networks with said one or more network backbones,**

~~114.~~ Ganz teaches that its repeater device is connects the wireless network to a network backbone. In particular, Ganz describes that it ~~maximize~~[maximizes](#) the bandwidth of network traffic of “*backbone connections*,” such as by “throttling open network connections down to the minimum guaranteed bandwidth.” (EX1005, 10:~~52-11;4~~[52-11-4](#).) (~~EX1005, 10:52-11:4~~[EX1002, ¶114.](#))

~~115.~~ Additionally, Ganz describes the software function of “load balancing” to “ensure efficiency of data transfer in the WBCR.” (EX1005, 12:12-21.) According to Ganz, “[t]he total bandwidth available to any single WBCR is limited only by the number of connections it has to other segments of the network. Since each individual link has an available bandwidth that is typically smaller than *the backbone connectivity for the network as a whole*, a load balancing mechanism is used for optimizing the total system throughput. This allows the creation of bandwidth on demand, by routing excess traffic through links that would

otherwise be underutilized.” (EX1005, 12:12-21.) Moreover, Figure 1 depicts that its repeaters connect “Local” or “Lan” networks with “Landline[s]” or a “Link to the Internet.”

(EX1005, Fig. 1; *see also id.*, 3:40-42 (“land line link 4 (*i.e.*, Internet or other private distribution data sources”). A POSITA would understand that a landline or Internet connection is provided via a network backbone, especially in view of Ganz’s disclosures that the WBCR is connected to a backbone. (~~EX1005, 12:12-21.) The internet is provided by an internet backbone. The internet backbone consists of high capacity fiber optic cables and routers operated by major telecommunications companies that form the internet's core infrastructure. These networks connect to each other at Internet Exchange Points, where they exchange traffic through peering agreements. Regional and local Internet Service Providers connect to the backbone through a tiered system, allowing data to flow from any source to any destination on the internet and back. This creates a global network that enables communication between any two points online.~~[EX1002, ¶115.](#))

- h) 1[g]: wherein said broadband wireless repeater or relay is used to support connectivity and/or position location capabilities for one or more mobile or portable devices, and**

~~116.~~ Ganz discloses QoS software that “includes bandwidth management functions that provide traffic control of the WBCR, allowing improved network

performance while enforcing traffic flows and other network policies.” (EX1005, 10:52-54.) These QoS functions include prioritization, which “provides the WBCR with the flexibility to distinguish between time-sensitive traffic and non-time

sensitive traffic and to give the former higher priority. A typical prioritization scheme assigns an administratively defined priority to each packet and then forwards the packet to a high, medium, or low priority queue.” (EX1005, 11:5-9.) [\(EX1002, ¶116.\)](#)

~~117.~~ Additionally, Ganz describes the software function of “load balancing” to “ensure efficiency of data transfer in the WBCR.” (EX1005, 12:12-21.) According to Ganz, “[t]he total bandwidth available to any single WBCR is limited only by the number of connections it has to other segments of the network. Since each individual link has an available bandwidth that is typically smaller than the backbone connectivity for the network as a whole, *a load balancing mechanism is used for optimizing the total system throughput.* This allows the creation of bandwidth on demand, *by routing excess traffic through links that would otherwise be underutilized.*” (EX1005, 12:12-21.) [\(EX1002, ¶117.\)](#)

~~118.~~ Ganz teaches that its controller permits network information to be

modified. For example, Ganz explains that “[m]onitoring and control of the WBCR is achieved by software controlled radio/data communications, between a host radio station and the WBCR... Throughput speeds and data packet drop rates can be measured periodically and *corrective steps taken to adjust the radio parameters remotely.*” (EX1005, 5:47-61.) Further, “[t]he controlling functions implemented as part of the BPMA/CA protocol provide for *remote dynamic load balancing among*

the users, and individually enhancing or reducing the allowable user packet size requests, thereby ensuring efficient network utilization for all users. Basic maintenance functions are performed remotely as well, such as *adding new users and user ID's, and updating user priority codes.*” (EX1005, 5:47-61.)

[\(EX1002,](#)

[¶118.\)](#)

~~119.~~To the extent PO argues that this limitation is not disclosed by Ganz, it is likewise expressly disclosed by Roese, and a POSITA would have been motivated to modify Ganz’ system to include Roese’s teachings for the reasons discussed

above. Roese discloses a “network entry device,” such as a wireless repeater, using network information in support of position location capabilities. (EX1012, 31:36-42 (“Network entry devices 114 can include, for example, switches,

routers, hubs, bridges, repeaters, wireless access points”).) Specifically, Roese describes that a network entry device can “determine its physical location” by “receiv[ing] location information from each of its neighboring devices.” (EX1012, 36:62-64; *see also id.*, 8:33-40 (“System 100 can employ a first System 100 can employ a first group of mechanisms/techniques for identifying the location of a device (e.g., 104, 114) that communicates via radio frequencies. For example, system 100 triangulates the location of a device using one or more wireless access points, such as 120a-b, associated with network entry devices 114, such as 114a and 114b, respectively, as shown in FIG. 1.”) Such location information can then be *used by a network*, such as to determine the position location of a user device. (EX1012, 9:47-50 (“System 100 also can use signal amplitude differential from the network entry devices 114a and 114b to determine relative location of user device 104b with respect to an antenna on network device 114a or 114b.”).

[\(EX1002, ¶119.\)](#)

- i) ~~i)~~ **1[h]: wherein said controller is configured or configurable to perform or for performing at least one of: a) ignore or filter out at least some signal or data transmissions from one or more undesired transmitters, users, networks, data sources, or noise sources; and b) instruct one or more devices or networks to ignore or disregard at least some signal or data transmissions of one or more undesired transmitters, undesired users, undesired networks, or noise sources.**

“a) ignore or filter out at least some signal or data transmissions from one or more undesired transmitters, users, networks, data sources, or noise sources”

~~120.~~ Ganz discloses that its WBCR includes a “firewall circuit 222,” which can “read IP addresses and protect the gates and authorize access by users,” and also “be programmed to pass through what ever services are required by the user without interference.” (EX1005, 10:33-42.) As was known with firewalls, they “can also block traffic from the Internet to the internal network, but permit internal users to communicate with the Internet.” (*Id.*; see also 13:2-4 (“The firewall 268, drops packets that don’t meet its rules for valid traffic.”).) A POSITA would have ~~understood~~undersood that, in other words, a firewall processes received data packets by inspecting their origin (*e.g.* Internet vs. internal) or the targeted service and blocking or allowing the data packet. (EX1002, ¶120.)

~~121.~~ Ganz also discloses that the WBCR performs “IP filtering,” which “allows for certain data packets to be blocked, *processed* according to QoS policies and used to assess and sort according to traffic load on each WBCR radio segment.” (*Id.*, 11:~~45-48~~45- 48.) IP filtering also “automatically drops (destroys) incorrectly formed packets or those which the system has been programmed to reject.” (*Id.*, 12:70-13:2.) (EX1002, ¶121.)

~~122.~~ Thus, a POSITA would understand that the controller in Ganz's WBCR is configurable to "ignore or filter out at least some signal or data transmissions," from undesired transmitters, users, networks, data sources, or noise sources.

(EX1002,

¶122.)

"b) instruct one or more devices or networks to ignore or disregard at least some signal or data transmissions of one or more undesired transmitters, undesired users, undesired networks, or noise sources"

~~123.~~ As discussed above, Ganz discloses ignoring or filtering out at least some signal or data transmissions of undesired transmitters, users, networks, data sources, or noise sources. Given that Ganz explains that its WBCR is configured to "*communicate with at least one end user* by either a direct electrical connection or a wireless connection" (EX1005, 2:46-50.), it would have been obvious to a POSITA that Ganz's WBCR could also perform the function of "instruct[ing] one or more devices or networks to ignore or disregard at least some signal or data transmissions." Ganz already discloses that its WBCR has information on "undesired" signal or data transmissions, as a well as means of communicating that information. Thus, a POSITA would have known that modifying Ganz's WBCR to

communicate information on “undesired” signal or data transmissions, thereby “instructing” end user devices to ignore or disregard those signal or data transmissions, could be done without technical challenge and with a reasonable expectation of success. (EX1002, ¶123.)

Summary report:	
Litera Compare for Word 11.14.0.42 Document comparison done on 12/22/2025 1:03:34 PM	
Style name: KL Standard	
Intelligent Table Comparison: Active	
Original filename: EX1002 - 337 Mahon Declaration - Excerpt.pdf	
Modified filename: 01 - 337 Petition - Excerpt.pdf	
Changes:	
Add	101
Delete	109
Move From	1
<u>Move To</u>	1
<u>Table Insert</u>	0
Table Delete	0
<u>Table moves to</u>	0
Table moves from	0
Embedded Graphics (Visio, ChemDraw, Images etc.)	0
Embedded Excel	0
Format changes	0
Total Changes:	212