

Exhibit 5

EXHIBIT 5 – U.S. Patent No. 9,667,337

Plaintiff asserts that at least the following “Accused Hotspot Instrumentalities” infringe the Asserted Claims of U.S. 9,667,337:

i) Smartphones:

Galaxy S20 (SM-G980, SM-G981); Galaxy S20+ (SM-G985, SM-G986); Galaxy S20 Ultra (SM-G988); Galaxy S20 FE (SM-G780, SM-G781); Galaxy S21 (SM-G991); Galaxy S21+ (SM-G996); Galaxy S21 Ultra (SM-G998); Galaxy S21 FE (SM-G990); Galaxy S22 (SM-S901); Galaxy S22+ (SM-S906); Galaxy S22 Ultra (SM-S908); Galaxy S23 (SM-S911); Galaxy S23+ (SM-S916); Galaxy S23 Ultra (SM-S918); Galaxy S23 FE (SM-S711); Galaxy S24 (SM-S921); Galaxy S24+ (SM-S926); Galaxy S24 Ultra (SM-S928); Galaxy S24 FE (SM-S821); Galaxy S25 (SM-S931); Galaxy S25+ (SM-S936); Galaxy S25 Ultra (SM-S938); Galaxy S25 Edge (SM-S935); Galaxy Z Flip 3 (SM-F711); Galaxy Z Flip 4 (SM-F721); Galaxy Z Flip 5 (SM-F731); Galaxy Z Flip 6 (SM-F741); Galaxy Z Fold 2 (SM-F916); Galaxy Z Fold 3 (SM-F926); Galaxy Z Fold 4 (SM-F936); Galaxy Z Fold 5 (SM-F946); Galaxy Z Fold 6 (SM-F956); Galaxy Note 20 (SM-N981); Galaxy Note 20 Ultra (SM-N986); Galaxy A32 5G (SM-A326); Galaxy A42 5G (SM-A426); Galaxy A12 (SM-A125); Galaxy A02s (SM-A025); Galaxy A54 5G (SM-A546); Galaxy A25 5G (SM-A256); Galaxy A26 5G (SM-A266); Galaxy A36 5G (SM-A366); Galaxy A16 5G (SM-A166); Galaxy A16 (SM-A165)

ii) Tablets:

Galaxy Tab S6 (SM-T860, SM-T865, SM-T866N); Galaxy Tab S6 5G (SM-T866N); Galaxy Tab S7 (SM-T870, SM-T875, SM-T878U); Galaxy Tab S7+ (SM-T970, SM-T976); Galaxy Tab S7 FE (SM-T730, SM-T736B); Galaxy Tab S8 (SM-X700, SM-X706); Galaxy Tab S8+ (SM-X800, SM-X806); Galaxy Tab S8 Ultra (SM-X900, SM-X906); Galaxy Tab S9 (SM-X710, SM-X716); Galaxy Tab S9+ (SM-X810, SM-X816); Galaxy Tab S9 Ultra (SM-X910, SM-X916); Galaxy Tab S10 FE (SM-X520, SM-X526); Galaxy Tab S10 FE+ (SM-X620); Galaxy Tab S10+ (SM-X826); Galaxy Tab S10 Ultra (SM-X920); Active4 Pro (SM-T636); Active5 (SM-X591B); Active5 Tactical Edition (SM-X591B); Active5 Pro (SM-X596)

iii) Personal Computers/ Laptops:

Galaxy Book S (SM-W767); Galaxy Book Go 5G (SM-X100); Galaxy Book Flex 2 Alpha (SM-X420); Galaxy Book Pro (SM-X50x); Galaxy Book Pro 360 (SM-X360); Galaxy Book2 360 (SM-X20x); Galaxy Book2 Pro (SM-X30x); Galaxy Book2 Pro 360 (SM-X360); Galaxy Book2 Pro 360 5G (SM-X366); Galaxy Book3 360 (SM-X40x); Galaxy Book3 Pro (SM-X50x); Galaxy Book3 Pro 360 (SM-X60x); Galaxy Book3 Pro 360 5G (SM-X66x); Galaxy Book4 (SM-X70x); Galaxy Book4 Ultra (SM-X7Ux); Galaxy Book4 Pro (SM-X7Px); Galaxy Book4 Pro 360 (SM-X7Mx);

Galaxy Book4 Edge (SM-X8Ex); Galaxy Book5 360 (SM-X90x); Galaxy Book5 Pro (SM-X91x); Galaxy Book5 Pro 360 (SM-X93x); Galaxy Book5 Pro 360 5G (SM-X936)

iv) Hospitality TVs:

Crystal UHD Smart Hospitality TV (HGxxHBU800); Smart Hospitality TV (HGxxHQ60A); 4K Hospitality TV (HGxxCU708); Crystal UHD Smart Hospitality TV (HGxxHAU800); 690 Series Hospitality TV (HGxxNx690); 890 Series Hospitality TV (HGxxNx890)

v) Smart Hubs:

SmartThings Hub (STH-ETH-250); Connect Home Pro (ET-WV530); Connect Home (ET-WV520); SmartThings Wi-Fi (ET-WV525KWEKUS); SmartThings Hub (2018) (GP-U999SJVLGDA); SmartThings Hub (GP-U999SJVLGDB)

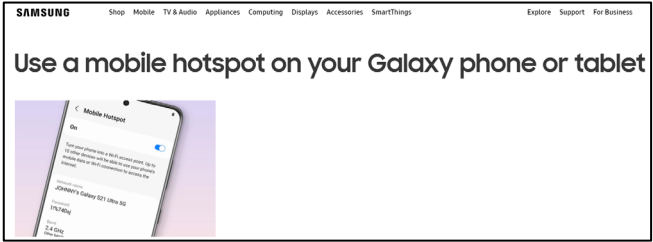
Claim 1	Accused Hotspot Instrumentalities ¹
<p>[1PRE] A broadband wireless repeater or relay, comprising:</p>	<p>The Accused Hotspot Instrumentalities can serve as a broadband wireless repeater when in a mode to operate as a mobile hotspot. So configured, the Accused Hotspot Instrumentalities connect one or more mobile devices via a Wi-Fi network to the Internet or via a cellular network to the Internet.</p> <p>For example, Samsung’s website explains how to use a mobile hotspot on a Galaxy phone or tablet.</p>  <p>See https://www.samsung.com/us/support/answer/ANS00079036/</p>

¹ Unless indicated otherwise, the evidence cited in this table is representative of the operation of the Accused Hotspot Instrumentalities and upon information and belief, the Accused Hotspot Instrumentalities function in a substantially similar manner for purposes of this chart, unless indicated otherwise.

[1A] at least one receiver or transceiver for signal or data reception from one or more devices;

The Accused Hotspot Instrumentalities include a receiver or transceiver for signal or data reception from a device (“connected device”), that is connected wirelessly to the Accused Hotspot Device via Wi-Fi 5/6/6E, 4G-LTE, and/or 5G.

The receiver and/or transceiver is shown by the Wi-Fi module (e.g., Wi-Fi/Bluetooth combo chip) and/or cellular module (e.g., 4G-LTE tuner/transceiver, 5G tuner/transceiver) of the Accused Hotspot Instrumentalities. The Wi-Fi/Bluetooth combo chip (e.g., Qualcomm WCN6855 and WCN7851-101) includes a receiver or transceiver for signal or data reception from the connected device. See <https://devicehd.com/smartphones/en/product/64328d1550d90c8ad32d8f6b/>; <https://devicehd.com/smartphones/en/product/64295291e5917e62545296b9/>

See the figure below showing the Qualcomm WCN6855 coupled to an application processor and antenna.

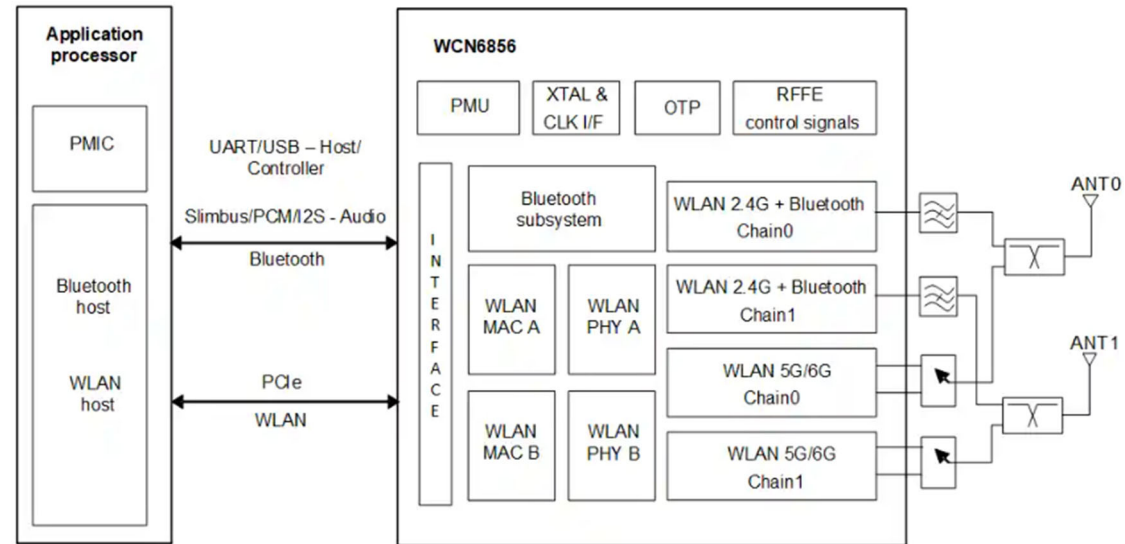

<https://docs.qualcomm.com/bundle/publicresource/topics/80-WL542-10/overview.html>

The cellular module (e.g., Exynos RF 5500) also comprises a receiver or transceiver for receiving signals via a cellular network.

<https://semiconductor.samsung.com/news-events/tech-blog/exynos-rf-5500-and-exynos-sm-5800-chips-making-5g-wireless-communication-possible/>In one example, the image below shows a circuit board from the Galaxy S20 Ultra, identifying a Murata KM9D19075 Wi-Fi module, in the orange rectangle, which comprises “at least one receiver or transceiver for signal or data reception from one or more devices.” See www.ifixit.com/Teardown/Samsung+Galaxy+S20+Ultra+Teardown/131607?srsItd=AfmBOorbKmG1FgZYkgqQsKc3mMYaHd6vA_c9nDDoDhWIkT_IkjlHRT-t

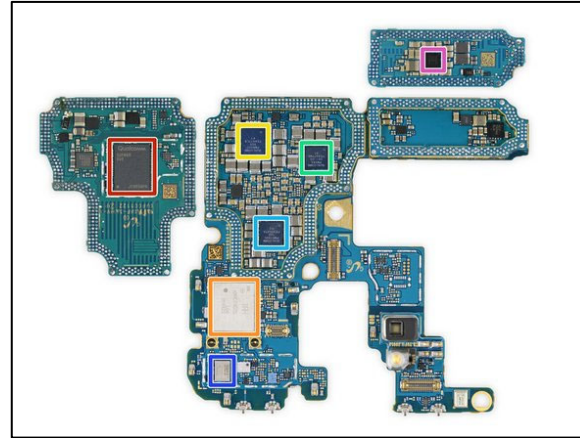

As another example, below is an image of a Galaxy S22 Ultra circuit board a Broadcom Wi-Fi 6/6E chip, which comprises “at least one receiver or transceiver for signal or data reception from one or more devices.” See www.techinsights.com/blog/samsung-galaxy-s22-ultra-teardown

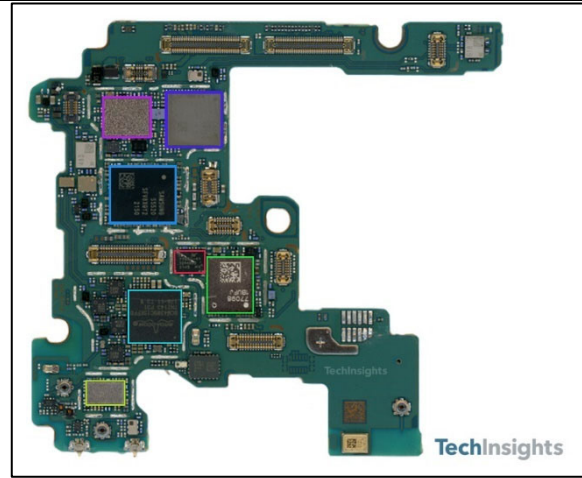

In another example, the image below shows a main circuit board from the Galaxy S10+, comprising a MediaTek 5G RF transceiver.

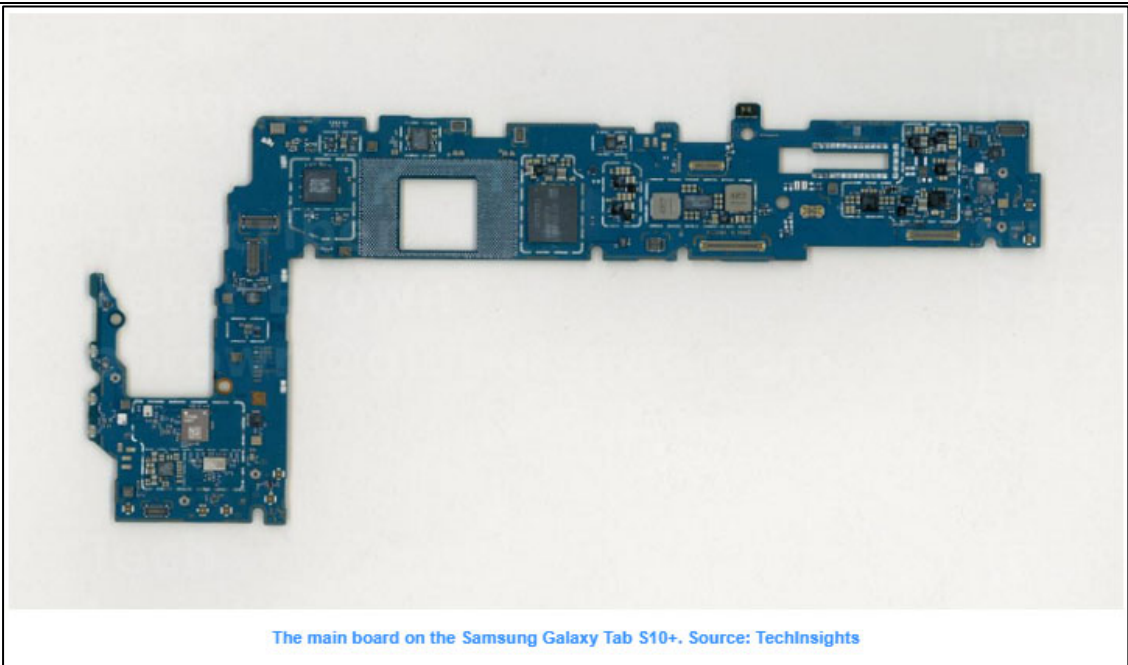
**Main board**

The main board of the Samsung Galaxy Tab S10+ includes the main memory and sensors for operation of the tablet. The electronic components found on the smart tablet include:

- ST Microelectronics' six-axis MEMS accelerometer
- Texas Instruments' 250 mA LDO regulator and 250 mA LDO regulator
- Murata's SAW filter, RxD front-end module,
- MediaTek's GPS receiver, clock buffer and 5G RF transceiver
- Diodes Inc.'s 300 mA/3.0 V LDO regulator
- Qorvo's RF antenna tuner and front-end module
- Infineon's SPDT RF switch
- Silergy's DC-DC converter
- Analog Devices' buck-boost regulator
- Vishay's RGBC/IR light sensor
- Cirrus Logic's Class-D audio amplifier
- Samsung's secure element chip

See <https://electronics360.globalspec.com/article/22285/techinsights-teardown-samsung-galaxy-tab-s10>

In another example, the Accused Hotspot Device comprises a Wi-Fi module configured to transmit and receive wireless signals, to perform the functionality of a SoftAP. Samsung’s website describes the specification of the HQ60A series hospitality TVs as including a software access point (SoftAP). The SoftAP feature allows the Hospitality TV to deploy a hotspot for the hotel guests to connect to the internet.

Samsung LYNK™ Cloud
Yes
Hospitality Plug&Play (Easy Set-up)
Yes
Hotel Channel List
Yes
Mixed Channel List (ATSC, DVB-T/T2/C/S2, Analog)
Yes
Energy Saving Mode (BLU Control)
Yes
Clock Back Up Supply
Yes
Soft AP
Yes
Samsung LYNK™ DRM
Yes
Security Mode
Yes

See <https://www.samsung.com/ca/business/commercial-tvs/hotel-tv/hq60a-4k-qlcd-hg65q60aanfxza/>

As shown in the image below, Samsung’s website describes the specifications of the HQ60A Series Hospitality TV as supporting the Wi-Fi 5 generation (i.e., IEEE 802.11ac). According to IEEE 802.11ac, the Accused Hotspot Device supports a channel width of up to 160 MHz and data transmission speeds of up to 6.93 Gbps.

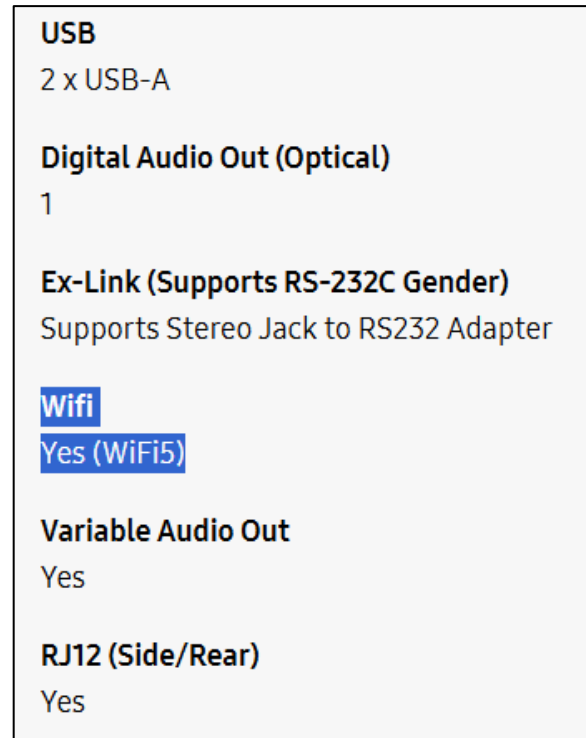

See *id.*

In another example, the Accused Hotspot Instrumentalities (e.g., Connect Home Pro) can connect a user mobile device to other smart devices through a Wi-Fi network (at least Wi-Fi 4 for speeds up to 600 Mbps). This allows a transceiver within the Accused

Hotspot Instrumentalities to send and receive wireless data over a Wi-Fi network. (See images below)

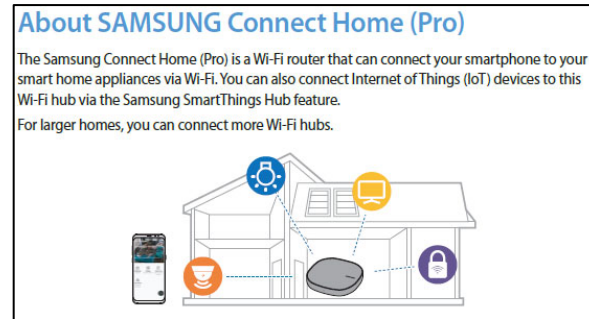

See <https://content.syndigo.com/asset/17adf894-afac-49a6-9e43-acc47d706188/original.pdf>

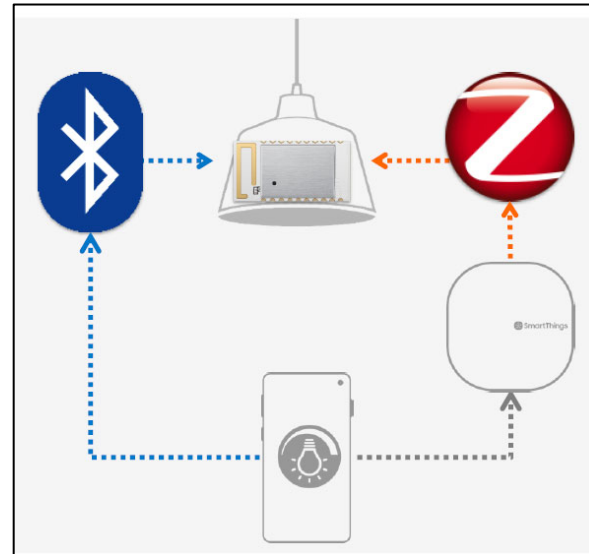

See https://download.led.samsung.com/led/file/resource/2020/06/Smart_Lighting_Solution_0602.pdf

	<p>An integrated circuit package (e.g., 5G system-on-a-chip) may comprise a plurality of functionalities within a single IC package such as signal encoding/decoding by a modem, frequency tuning by a front-end module, and/or transmitter/receiver by a transceiver. The IC is in communication with one or more antennas or an antenna array to wirelessly transmit and receive wireless data over a Wi-Fi network or cellular network.</p> <p>See claim elements [1B] and [1C] below.</p>
<p>[1B] at least one transmitter or transceiver for signal or data transmission to one or more devices, wherein the transceiver for signal or data reception and the transceiver for signal or data transmission may be the same or different; and</p>	<p>The Accused Hotspot Instrumentalities include a transmitter or transceiver for signal or data transmission to one or more devices (e.g., “connected device”), that is connected wirelessly to the Accused Hotspot Device via Wi-Fi 5/6/6E, 4G-LTE, and/or 5G.</p> <p>The transmitter and/or transceiver is provided by the Wi-Fi module (e.g., Wi-Fi/Bluetooth combo chip) and/or cellular module (e.g., 4G-LTE tuner/transceiver, 5G tuner/transceiver) of the Accused Hotspot Instrumentalities. The Wi-Fi/Bluetooth combo chip (e.g., Qualcomm WCN6855 and WCN7851-101) comprises a receiver or transceiver for signal or data transmission to the connected device. See https://devicehd.com/smartphones/en/product/64328d1550d90c8ad32d8f6b/; https://devicehd.com/smartphones/en/product/64295291e5917e62545296b9/</p> <p>See the figure below showing the Qualcomm WCN6855 coupled to an application processor and antenna.</p>

	<p>https://docs.qualcomm.com/bundle/publicresource/topics/80-WL542-10/overview.html</p> <p>The cellular module (e.g., Exynos RF 5500) also comprises a transmitter or transceiver for transmitting signals via a cellular network.</p> <p>https://semiconductor.samsung.com/news-events/tech-blog/exynos-rf-5500-and-exynos-sm-5800-chips-making-5g-wireless-communication-possible/</p> <p>See claim elements [1A] above and [1C] below.</p>
<p>[1C] a controller that is configured or configurable for operation in one or more wireless networks,</p>	<p>The Accused Hotspot Instrumentalities include a controller that is configured or configurable for operation in a Wi-Fi network (e.g., Wi-Fi 5/802.11ac, Wi-Fi 6/802.11ax, or Wi-Fi 6E/ 802.11ax networks) and/or a cellular network (e.g., 4G LTE or 5G), which are wireless networks.</p> <p>For example, the Galaxy S20 Ultra comprises, among other things, a Qualcomm Snapdragon 865 processor in communication with a STMicroelectronics STM32G071EB 32-bit ARM microcontroller and a Qualcomm SDX55M 5G modem.</p>

www.ifixit.com/Teardown/Samsung+Galaxy+S20+Ultra+Teardown/131607?srltid=AfmBOorbKmG1FgZykgqQsKc3mMYaHd6vA_c9nDDoDhWlKt_IkjlHRT-t

In another example, the Galaxy S22 Ultra comprises, among other things, a Qualcomm Snapdragon 8 Gen 1 in communication with a Samsung RF Transceiver S5520, a Broadcom Front-End Module AFEM-9140, a Skyworks Front-End Module SKY58083-11, a Broadcom Wi-Fi 6/6E&BT 5.0 SoC BCM4389, and a Qorvo Front-End Module QM77098.

www.techinsights.com/blog/samsung-galaxy-s22-ultra-teardown

In another example, the Accused Hotspot Instrumentalities (e.g., Hospitality TVs) comprise a processor such as the Crystal Processor 4K, Quantum Processor Lite, NQ4 AI Gen2, NQ4 AI Gen3, NQ8 AI Gen3, RISC-V SoCs (e.g., SiFive P470) Processors. These processors communicate with the Wi-Fi modules (e.g., Realtek MT7668AUN, Broadcom BCM43143) for operation in a wireless network.

<https://manuals.plus/samsung/wcf734m-wi-fi-bluetooth-combo-module-manual>

<https://manualmachine.com/samsung/spwb43143u/11353954-user-manual/>

The image below shows a network configuration menu for the Samsung TV operating system, Tizen, which is executed by a controller of a Hospitality TVs. The operating system is programable through a network API, and causes the controller to configure the TV's network settings to identify wireless devices.

```

NetworkManager
void removeNetworkStateChangeListener(unsigined long listener);
DOMString getWiFiSSID();
long getWiFiSignalStrengthLevel();
NetworkWiFiSecurityMode getWiFiSecurityMode();
NetworkWiFiEncryptionType getWiFiEncryptionType();
DOMString getSecondaryDns();
void setDhcpOption6Field(DOMString vendorName);
void removeDhcpOption6Field();
DOMString getCurrentDhcpOption6Field();
DOMString checkCurrentIpWith6Field();
void enableSoftAP();
void disableSoftAP();
boolean isSoftAPEnabled();
DOMString getSoftAPSSID();
void setSoftAPChannel(long channel);
DOMString getSoftAPSecurityKey();
void setSoftAPSignalStrength(unsigined long power);
void setEAPCAFilePath(DOMString path);
void setEAPPassphrase(DOMString name, DOMString password);
long getWiFiFrequency();

```

	<p>See https://developer.samsung.com/smarttv/develop/api-references/samsung-product-api-references/network-api.html</p> <p>In another example, a controller (e.g., Exynos i T200) in communication with a transceiver of the Accused Hotspot Instrumentalities (e.g., smart hub) is configured or configurable for operations with at least a wireless local area network (WLAN) and wide area network (WAN).</p> <div data-bbox="779 446 1892 1063" style="border: 1px solid black; padding: 10px; margin: 10px 0;"> <h3 style="text-align: center;">Specifications</h3> <hr/> <p>Processor</p> <table border="0" style="width: 100%;"> <tr> <td style="width: 50%;">CPU Speed</td> <td style="width: 50%;">CPU Type</td> </tr> <tr> <td>716MHz</td> <td>Quad-Core</td> </tr> </table> <hr/> <p>Memory</p> <table border="0" style="width: 100%;"> <tr> <td style="width: 50%;">RAM Size (MB)</td> <td style="width: 50%;">Storage (GB)</td> </tr> <tr> <td>512</td> <td>8</td> </tr> </table> <hr/> <p>Connectivity</p> <table border="0" style="width: 100%;"> <tr> <td style="width: 25%;">Bluetooth Version</td> <td style="width: 25%;">Wi-Fi Version</td> <td style="width: 25%;">Wi-Fi Speed</td> <td style="width: 25%;">Wi-Fi - Security</td> </tr> <tr> <td>Bluetooth v4.1</td> <td>802.11 a/b/g/n/ac, 2.4G+5GHz, VHT80 2x2 MU MIMO</td> <td>Up to 866Mbps@ 5GHz + 400Mbps @ 2.4 GHz (AC1300)</td> <td>WPA2, WPA2-PSK</td> </tr> </table> </div> <p>https://news.samsung.com/global/samsung-begins-mass-production-of-first-exynos-branded-iot-solution-the-exynos-i-t200; https://www.samsung.com/ca/smartthings/hub/smartthings-wi-fi-et-wv525bwegca/</p> <p>See claim elements [1A] and [1B] above.</p>	CPU Speed	CPU Type	716MHz	Quad-Core	RAM Size (MB)	Storage (GB)	512	8	Bluetooth Version	Wi-Fi Version	Wi-Fi Speed	Wi-Fi - Security	Bluetooth v4.1	802.11 a/b/g/n/ac, 2.4G+5GHz, VHT80 2x2 MU MIMO	Up to 866Mbps@ 5GHz + 400Mbps @ 2.4 GHz (AC1300)	WPA2, WPA2-PSK
CPU Speed	CPU Type																
716MHz	Quad-Core																
RAM Size (MB)	Storage (GB)																
512	8																
Bluetooth Version	Wi-Fi Version	Wi-Fi Speed	Wi-Fi - Security														
Bluetooth v4.1	802.11 a/b/g/n/ac, 2.4G+5GHz, VHT80 2x2 MU MIMO	Up to 866Mbps@ 5GHz + 400Mbps @ 2.4 GHz (AC1300)	WPA2, WPA2-PSK														
<p>[1D] said controller communicating with said at least one receiver or transceiver for</p>	<p>The controller in the Accused Hotspot Instrumentalities communicates with the Wi-Fi module and/or the cellular module (e.g., 4G-LTE tuner/transceiver, 5G</p>																

<p>signal or data reception and said at least one transmitter or transceiver for signal or data transmission,</p>	<p>tuner/transceiver) for data reception and transmission via Wi-Fi and cellular networks. The controller communicates with and/or includes the Wi-Fi module and/or the cellular module for signal processing, decoding, controlling application data, and signal I/O management.</p> <p>For example, the controller of the Accused Hotspot Instrumentalities communicates with and interfaces with the transmitters/receivers/transceivers to identify and communicate with connected devices through Wi-Fi protocols, such as Wi-Fi 5/6/6E. The controller uses the IP and/or MAC addresses to identify connected devices. See e.g., www.techtarget.com/searchnetworking/answer/What-is-the-difference-between-an-IP-address-and-a-physical-address/.</p> <p>In another example, the controller of the Accused Hotspot Instrumentalities utilizes WPA2 and/or WPA3 protocols to allow for secure broadcasting of a Wi-Fi hotspot, which employs a handshake sequence that requires identification via network information of devices requesting to join the mobile hotspot.</p> <p>See https://insights.samsung.com/2022/12/16/how-to-turn-your-galaxy-smartphone-into-a-hotspot-3/; and https://en.wikipedia.org/wiki/Wi-Fi_Protected_Access.</p> <p>See claim elements [1C] above.</p>
<p>[1E] wherein at least one of said receiver or transceiver for signal or data reception and said transmitter or transceiver for signal or data transmission either or both transmit and receive at an instantaneous or overall occupied bandwidth of 100 MHz or more or have a data transmission rate of 100 Megabits per second or more,</p>	<p>The receivers and transmitters of the Accused Products support Wi-Fi 5/6/6E which have channels with an instantaneous or overall occupied bandwidth of 100 MHz or more. According to the IEEE 802.11 standards, the Wi-Fi generations Wi-Fi5 (802.11ac), Wi-Fi6 (802.11ax-2019), and Wi-Fi6E (802.11ax-2021), all provide 160 MHz channel widths.</p> <p>For example, IEEE 802.11ax (Wi-Fi 5) allows for data transmissions over a contiguous or non-contiguous 160 MHz bandwidth. The 160 MHz contiguous spectrum comprises 8 channels (20 MHz) that are bonded together. The 160 MHz non-contiguous spectrum comprises two 4 channels (20 MHz) that are bonded together and concatenated to form 160 MHz non-contiguous spectrum. The 160 MHz bandwidth supports data rates of up to 6.93 Gbps, but does not indicate a minimum or lower bound for the data rate.</p>

See e.g., help.keenetic.com/hc/en-us/articles/360012060379-Available-channels-on-the-5-GHz-Wireless-network, and help.keenetic.com/hc/en-us/articles/360010536300-What-you-need-to-know-about-Wi-Fi-6-IEEE-802-11ax

The Accused Hotspot Instrumentalities (e.g., smartphones, tablets, 5G notebooks) also transmit and receive communication via 4G LTE or 5G cellular networks, which have channels with an instantaneous or overall occupied bandwidth of 100 MHz or more.

Aggregated 4G-LTE carrier channels, such as aggregated Band 41 channels, have a bandwidth of 100 MHz or more. 5G has several bands (including but not limited band n41, n48, n77, n78, n79, n90, n257, n258, n259, n260, n261) that have bandwidths of 100 MHz or more.

Additionally, the data rates for 4G-LTE and 5G cellular networks are capable of over 100 Mbps. See <https://www.qualcomm.com/news/releases/2022/05/qualcomm-unveils-new-features-snapdragon-x70-modem-rf-system>.

In another example, the Accused Hotspot Instrumentalities (e.g., smart hub) are configured to transmit or receive wireless signals or data at a data rate of 100 Mbps or more, based on Wi-Fi 5 (802.11ac). See image below.

	<div style="text-align: center;">Specifications</div> <hr/> <p>Processor</p> <table border="0"> <tr> <td>CPU Speed</td> <td>CPU Type</td> </tr> <tr> <td>716MHz</td> <td>Quad-Core</td> </tr> </table> <hr/> <p>Memory</p> <table border="0"> <tr> <td>RAM Size (MB)</td> <td>Storage (GB)</td> </tr> <tr> <td>512</td> <td>8</td> </tr> </table> <hr/> <p>Connectivity</p> <table border="0"> <tr> <td>Bluetooth Version</td> <td>Wi-Fi Version</td> <td>Wi-Fi Speed</td> <td>Wi-Fi - Security</td> </tr> <tr> <td>Bluetooth v4.1</td> <td>802.11 a/b/g/n/ac, 2.4G+5GHz, VHT80 2x2 MU MIMO</td> <td>Up to 866Mbps@ 5GHz + 400Mbps @ 2.4 GHz (AC1300)</td> <td>WPA2, WPA2-PSK</td> </tr> </table> <p>https://news.samsung.com/global/samsung-begins-mass-production-of-first-exynos-branded-iot-solution-the-exynos-i-t200; https://www.samsung.com/ca/smartthings/hub/smartthings-wi-fi-et-wv525bwegca/</p>	CPU Speed	CPU Type	716MHz	Quad-Core	RAM Size (MB)	Storage (GB)	512	8	Bluetooth Version	Wi-Fi Version	Wi-Fi Speed	Wi-Fi - Security	Bluetooth v4.1	802.11 a/b/g/n/ac, 2.4G+5GHz, VHT80 2x2 MU MIMO	Up to 866Mbps@ 5GHz + 400Mbps @ 2.4 GHz (AC1300)	WPA2, WPA2-PSK
CPU Speed	CPU Type																
716MHz	Quad-Core																
RAM Size (MB)	Storage (GB)																
512	8																
Bluetooth Version	Wi-Fi Version	Wi-Fi Speed	Wi-Fi - Security														
Bluetooth v4.1	802.11 a/b/g/n/ac, 2.4G+5GHz, VHT80 2x2 MU MIMO	Up to 866Mbps@ 5GHz + 400Mbps @ 2.4 GHz (AC1300)	WPA2, WPA2-PSK														
<p>[1F] wherein said broadband wireless repeater or relay is connected or connectable to one or more network backbones for connecting said one or more wireless networks with said one or more network backbones,</p>	<p>The controller in the Accused Hotspot Instrumentalities is connected or connectable to one or more network backbones for connecting said one or more wireless networks with said one or more network backbones.</p> <p>“one or more wireless networks” refer to Wi-Fi networks provided by the Accused Hotspot Instrumentalities.</p> <p>“one or more network backbones” refer to internet (e.g., wide area network) connected to the backend of a cellular network (e.g., 4G-LTE or 5G) to which the Accused Hotspot Device is connected.</p>																

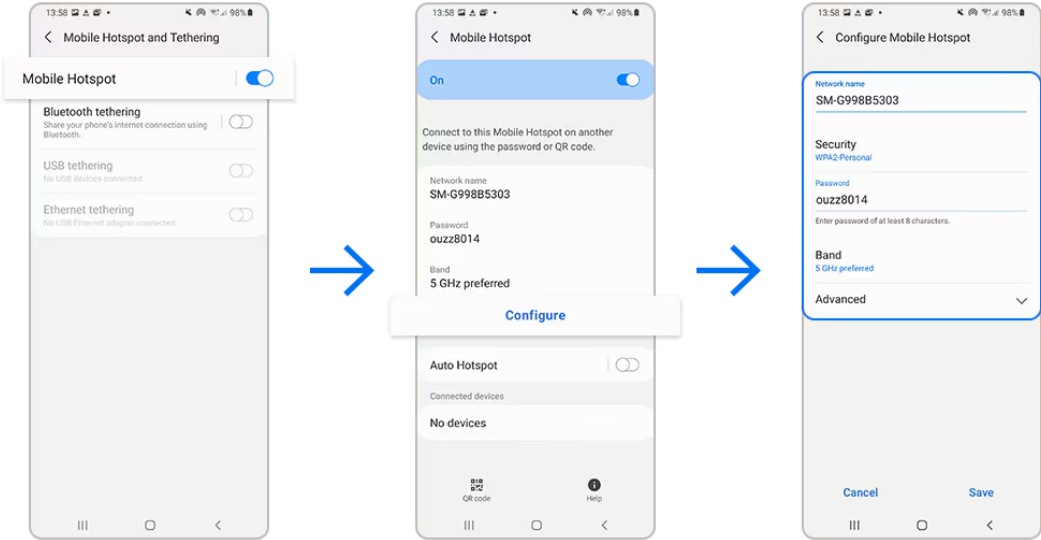
	<p>The Accused Hotspot Instrumentalities are connected to or connectable to a wide area network through a wired or wireless connection through a backend of a cellular network (e.g., 4G-LTE or 5G).</p>
<p>[1G] wherein said broadband wireless repeater or relay is used to support connectivity and/or position location capabilities for one or more mobile or portable devices, and</p>	<p>The Accused Hotspot Instrumentalities at least can be used to support connectivity and/or position location capabilities by providing internet protocol (IP) network connectivity for mobile devices connected via a Wi-Fi hotspot.</p> <p>For example, the Accused Hotspot Instrumentalities can reduce latency and jitter with traffic shaping and application prioritization. The Accused Hotspot Instrumentalities can also limit the amount of data consumed by consumed by connected devices.</p> <div data-bbox="779 586 1898 1377" style="border: 1px solid black; padding: 10px;"> <p>Step 1. Tap Mobile Hotspot.</p> <p>Step 2. Tap Configure.</p> <p>Step 3. Set the Network name, Security, Password, or Band.</p>  <p>If the mobile hotspot is not found, on your device, tap Configure and set Band to 2.4 GHz, tap Advanced, and then tap the Hidden network switch to deactivate it.</p> </div>

	<p>See https://www.samsung.com/ph/support/mobile-devices/how-to-use-and-configure-a-mobile-hotspot-on-your-galaxy-phone/</p> <p>In another example, the Accused Hotspot Device can share emergency location information for E911 services with a connected device through the mobile hotspot. Additionally, the connected device can access GNSS information from the Accused Hotspot Device through the mobile hotspot.</p> <p>See Claim [8] below.</p>
<p>[1H] wherein said controller is configured or configurable to perform or for performing at least one of:</p> <p>a) ignore or filter out at least some signal or data transmissions from one or more undesired transmitters, users, networks, data sources, or noise sources; and</p> <p>b) instruct one or more devices or networks to ignore or disregard at least some signal or data transmissions of one or more undesired transmitters, undesired users, undesired networks, or noise sources.</p>	<p>The Accused Hotspot Instrumentalities include a controller that performs elements (a). The controller performs elements (a) by at least ignoring or filtering signals received by the connected device.</p> <p>The controller performs element (a) by at least ignoring or filtering signals received from a wide area network and not providing the signal to a connected device. The wireless communications can be filtered or ignored based on MAC Address filtering, IP address filtering, DNS address filtering, port filtering, and/or quality of service (QoS).</p> <p>In one example, the Accused Hotspot Instrumentalities show the mobile user devices connected to the Wi-Fi network provided by the mobile hotspot. The user can select a connected device for a list of connected device and block the device from the network. The controller can configure network settings (e.g., blacklist, firewall settings) of the Accused Hotspot Instrumentalities to filter out wireless data transmissions (e.g., signals or data communication) based on blocked (blacklisted) MAC addresses or source IP addresses. This can prevent a previously connected device from establishing a connection to the mobile hotspots, based on a blacklisted MAC address of the device.</p>

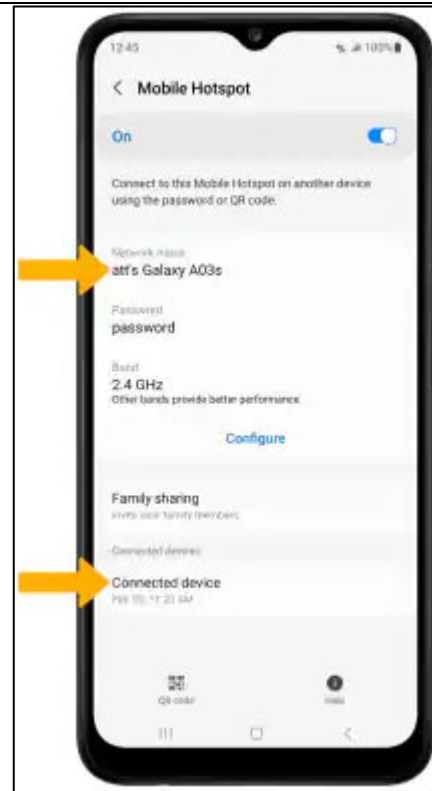

See <https://www.att.com/device-support/article/wireless/KM1472824/Samsung/SamsungSMA037U>; and devices.vodafone.com.au/samsung/galaxy-s21-5g-android-11-0/connectivity/use-your-phone-as-wi-fi-hotspot/

The Accused Hotspot Instrumentalities are configured with a 5G modem (e.g., Qualcomm x75) to filter or ignore noise sources through signal processing. For example, the Accused Hotspot Instrumentalities can filter waveforms in the frequency domain with OFDM to filter out signals in the same frequency domain.

4.1.2 Enabling efficient services multiplexing with windowed OFDM

In order to efficiently support multiplexing of 5G services, both in-band and out-of-band emissions must be kept to a minimum, so that services being transmitted on adjacent frequency channels do not interfere with one another. OFDM allows for waveform post-processing, such as windowing in the time domain or **filtering** in the frequency domain, to improve frequency localization. Figure 11 below showcases different 5G services, utilizing different 5G NR OFDM numerologies, multiplexed on the same frequency channel.

Figure 11: 5G NR will efficiently multiplex different services

See https://www.qualcomm.com/content/dam/qcomm-martech/dm-assets/documents/draft_whitepaper_-_leading_the_technology_inventions_for_a_unified_more_capable_air_interface_v.1.0.pdf

See https://docs.qualcomm.com/bundle/publicresource/87-27161-1_REV_C_Snapdragon_X75_5G_Modem-RF_System_Product_Brief.pdf

See claim [17] below.

Claim 2	Accused Instrumentalities
2. The broadband wireless repeater or relay of claim 1, wherein at least one of said one or more network backbones to which said controller is connected or connectable is a wired backbone.	<p>Plaintiff asserts that the Hospitality TVs, Smart hubs, and Personal Computers infringe claim 2. These devices include a controller that is connected or connectable is a wired backbone.</p> <p>For example, the Smart hubs comprise an ethernet port to connect to a wired backbone through a wide area network.</p>



<https://www.samsung.com/ca/smartthings/hub/smartthings-wi-fi-et-wv525bwegca/>

In another example, the Hospitality TVs comprise an ethernet port to connect to a wired backbone through a wide area network.

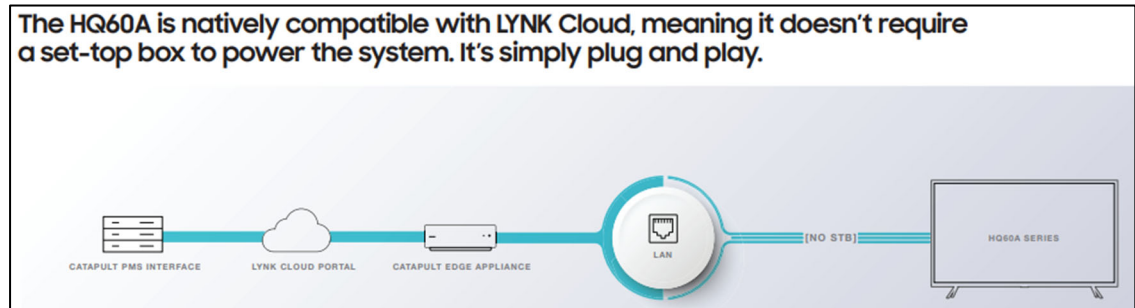

See https://image-us.samsung.com/SamsungUS/samsungbusiness/tvs/hospitality/luxury/hq60a-series-43/HTV_HQ60A_SERIES.pdf

In another example, the Personal Computers (e.g., Samsung Galaxy Book series) comprise a Thunderbolt 4 input connection to send or receive local area network signals to a wired backbone through a wide area network.

	<u>Galaxy Book5 360</u>	<u>Galaxy Book5 Pro</u>	<u>Galaxy Book5 Pro 360</u>
	AI-powered flexibility	The AI PC for pros	2-in-1 AI PC Power
	Windows 11 Home	Windows 11 Home	Windows 11 Home
	Intel® Core™ Ultra 7 Series 2 Processor 256V	Intel® Core™ Ultra 7 Series 2 Processor 256V / 258V	Intel® Core™ Ultra 7 Series 2 Processor 256V
	Included	Included	Included
	Copilot AI assistance Copilot+ PC*	Copilot AI assistance Copilot+ PC*	Copilot AI assistance Copilot+ PC*
	15.6" FHD AMOLED display with touchscreen	14" or 16" 3K Dynamic AMOLED 2X, Anti-reflective display with touchscreen	16" 3K Dynamic AMOLED 2X, Anti-reflective display with touchscreen
	1 x HDMI 2 x Thunderbolt™ 4	1 x HDMI 2.1 2 x Thunderbolt™ 4	1 x HDMI 2.1 2 x Thunderbolt™ 4
	See https://insights.samsung.com/2025/03/05/how-thunderbolt-4-is-changing-monitor-technology-2/		
Claim 3	Accused Instrumentalities		
3. The broadband wireless repeater or relay of claim 2, wherein said wired backbone is selected from a group consisting of T1, T3, DSL, cable, cable modem, fiber, optical cable, copper lines, coax, phone, ethernet, and internet.	Plaintiff asserts that the Hospitality TVs, Smart hubs, and Personal Computers infringe claim 3. These devices comprise a wired backbone, selected from a group consisting of T1, T3, DSL, cable, cable modem, fiber, optical cable, copper lines, coax, phone, ethernet, and internet. See claim [2] above.		

Claim 6	Accused Hotspot Instrumentalities
<p>6. The broadband wireless repeater or relay of claim 1, wherein said controller is configured to or configurable to perform a).</p>	<p>The controller of the Accused Hotspot Instrumentalities is configured or configurable to ignore or filter out at least some signal or data transmissions from one or more undesired transmitters, users, networks, data sources, or noise sources, as described in a) of element [1H].</p> <p>See claim elements [1H] above and claim [17] below.</p>
Claim 8	Accused Instrumentalities
<p>8. The broadband wireless repeater or relay of claim 1, wherein said controller is configured to or configurable to perform network provisioning or monitoring.</p>	<p>The controller of the Accused Hotspot Instrumentalities are configured or configurable to perform network provisioning or monitoring with one or more wireless devices.</p> <p>For example, the Accused Hotspot Instrumentalities are configured or configurable to deploy a hotspot (i.e., wireless local area network) for one or more wireless devices. By establishing a wireless connection between the one or more wireless devices with the WLAN, the Accused Hotspot Instrumentalities perform network provisioning.</p> <p>Additionally, the Accused Hotspot Instrumentalities monitor the data throughput shared with the one or more wireless devices.</p> <p>In another example, the Accused Hotspot Instrumentalities are configured or configurable to manage intelligent Wi-Fi settings that are used to configure the network connections such as prioritizing real-time data detecting suspicious networks, or reducing battery consumption by analyzing Wi-Fi traffic patterns. See the image of an Accused Hotspot Instrumentality below.</p>

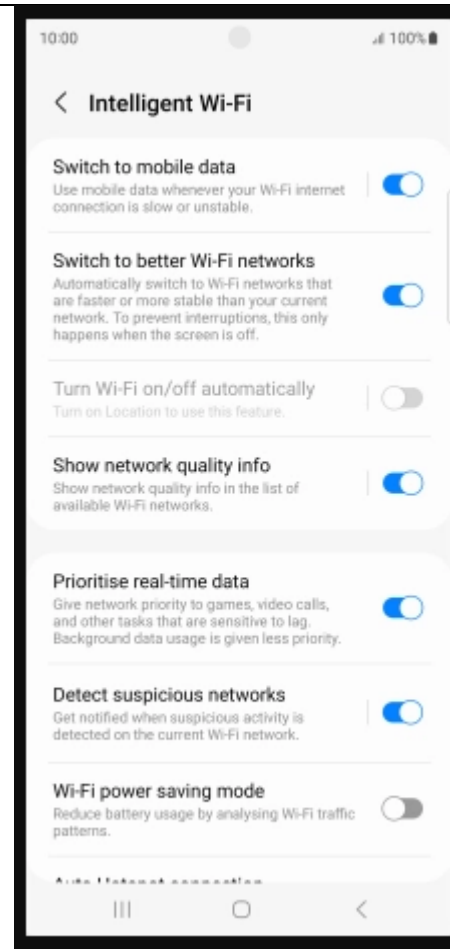

See <https://deviceguides.vodafone.co.uk/samsung/galaxy-s23-ultra-android-13/troubleshooting/connectivity/my-phone-uses-a-large-amount-of-mobile-data/196/>

In another example, the Samsung developer documentation of the Accused Hotspot Instrumentalities (e.g., Hospitality TVs), for the Tizen Operating system, states “[t]he SoftAP module allows a device to act as a Soft Access Point (SoftAP), enabling other devices to connect to the network it creates. Applications can use this module to configure and monitor the SoftAP’s status, manage network connectivity, and adjust

security settings. It is primarily used in IoT environments to easily set up and maintain network access points.” See https://docs.tizen.org/application/native/api/common/latest/group__CAPI__NETWORK__SOFTAP__MODULE.html

The SoftAP function is characterized in the industry as a software created wireless hotspot that can be deployed by a hospitality TV. See image below

Soft AP

Software-enabled Access Point (SoftAP) is a "virtual" Wi-Fi feature that uses software to create a wireless hotspot. The current version supports Bridge Mode, which enables network managers to control connected devices

See <https://www.ggear.com.kh/information-display/55-smart-hotel-tv-ut660h-series/>

In another example, the document below shows hardware and firmware configurations for Accused Hotspot Instrumentalities, designed to protect wireless data communications.

SmartThings is built from the ground up to protect the device and users' data securely

- Secure boot (SmartThings level 2 security)
- H/W & F/W security (Protected external ports)
- Protected storage / communication (AES-128 encryption)
- Set-up mode / Proximity set-up
- Compliance with CA SB-327

See <https://download.led.samsung.com/led/file/resource/2020/06/>

	<p>Smart_Lighting_Solution_0602.pdf</p> <p>See also claim [9] below.</p>
<p>Claim 9</p>	<p>Accused Hotspot Instrumentalities</p>
<p>9. The broadband wireless repeater or relay of claim 8, wherein the network provisioning or monitoring includes one or more of:</p> <p>i) bandwidth or delay provisioning of repeated or relayed transmissions,</p> <p>ii) application prioritization,</p> <p>iii) prioritizing, delaying or altering of data transmissions, traffic, or bandwidth, and</p> <p>iv) monitoring or measuring traffic from one or more devices, users or networks.</p>	<p>The network provisioning and monitoring for the Accused Hotspot Instrumentalities includes one or more of: i) bandwidth or delay provisioning of repeated or relayed transmissions, ii) application prioritization, iii) prioritizing, delaying or altering of data transmissions, traffic, or bandwidth, and iv) monitoring or measuring traffic from one or more devices, users or networks.</p> <p>In one example, the Accused Hotspot Instrumentalities include a battery saver mode that throttles bandwidth for connected wireless devices. This mode reduces network performance of the connected wireless devices and conserve power for the Accused Hotspot Instrumentalities.</p> <p>In another example, the Accused Hotspot Instrumentalities are configured or configurable to select or dynamically select the WLAN frequency (e.g., 2.4GHz, 5 GHz) which provides a tradeoff between higher bandwidth but lower connectivity distance, or wider connectivity distance but lower bandwidth.</p>

Step 1. Tap Mobile Hotspot.

Step 2. Tap Configure.

Step 3. Set the Network name, Security, Password, or Band.

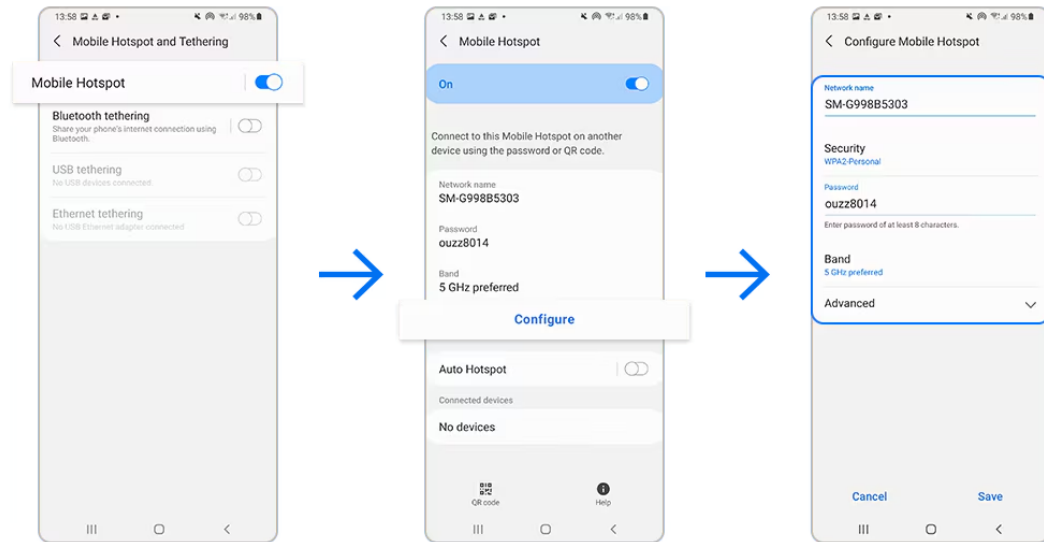

If the mobile hotspot is not found, on your device, tap **Configure** and set **Band** to 2.4 GHz, tap **Advanced**, and then tap the **Hidden network** switch to deactivate it.

See <https://www.samsung.com/ph/support/mobile-devices/how-to-use-and-configure-a-mobile-hotspot-on-your-galaxy-phone/>

In another example, the Accused Hotspot Instrumentalities are configurable to prioritize traffic for the Accused Hotspot Instrumentalities (e.g., smartphone or tablet) first, over communications for the wireless devices connected on the wireless hotspot (i.e., “prioritize real-time traffic” configuration option for the Mobile Hotspot). The prioritization may be based on application or traffic information.

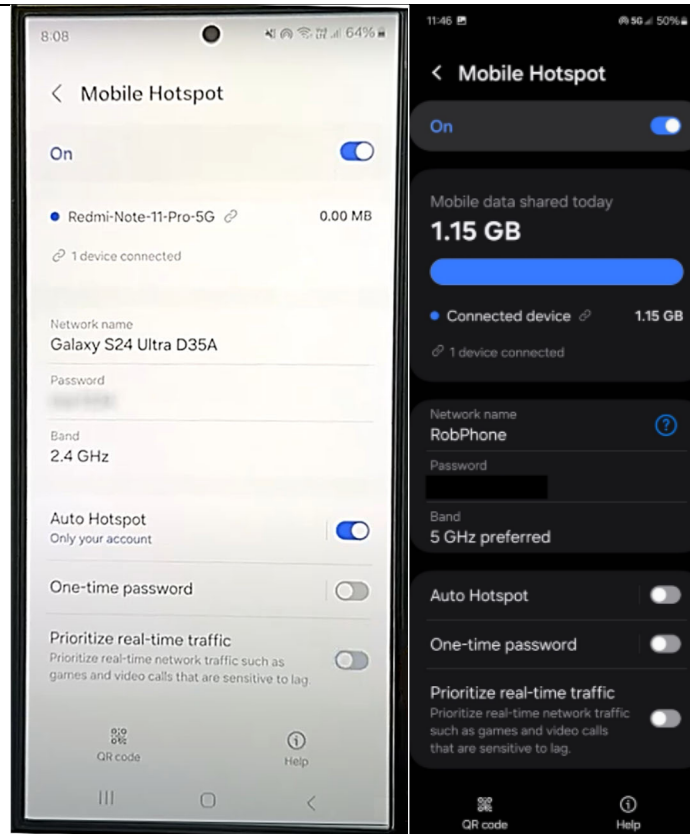

See <https://www.youtube.com/watch?v=yO0biK2PgcY>, and <https://eu.community.samsung.com/t5/galaxy-z-fold-z-flip/how-do-i-stop-the-hotspot-from-turning-off-automatically-on-z/td-p/10411303>

In another example, the image below shows step-by-step instructions for configuring a mobile hotspot in a Samsung smartphone or tablet. The instructions cause the Accused Hotspot Device to provision wireless network resources for a wireless local area network.



Connection options for your Galaxy phone or tablet

Mobile Hotspot

Use your device to create a Wi-Fi network, enabling other devices to connect and access the internet using your mobile data or Wi-Fi connection.

- 1** Swipe down from the top of the screen, and then tap the **Settings** icon.
- 2** Tap **Connections**, and then tap **Mobile Hotspot and Tethering**.
- 3** Tap **Mobile Hotspots**, and then turn on the **switch** at the top of the screen.
- 4** Tap the Network name, and then customize your desired information. The following options will now be available:
 - **Network name:** View and change the name of your hotspot.
 - **Password:** View and change the password for your hotspot.
 - **Band:** Set the radio band for the hotspot. **2.4 Ghz** is compatible with more devices, and **5 Ghz** will provide better performance.
 - **Security:** Select the hotspot's security level.
 - You can also tap **Advanced** to edit additional settings, such as MAC address type, Hidden network, Power saving mode, Wi-Fi sharing, and more.
- 5** Tap **Save** to apply your changes.
- 6** Now, on the device you want to connect, open the Wi-Fi settings, and then search for and tap the mobile hotspot network name you set up. Enter the password, and then tap **Connect**.

Note: If the Mobile hotspot is set to Hidden, tap **Add network** at the bottom of the Wi-Fi menu first, and then enter the network information

7 To ensure the connection is working, open the browser or an app that requires internet access on the receiving device.

See <https://www.samsung.com/us/support/answer/ANS10002546/>

In another example, the Accused Hotspot Instrumentalities can monitor and measure the amount of data shared with the connected wireless device. The image below shows the measured traffic throughput for the connected device by the Accused Hotspot Device.

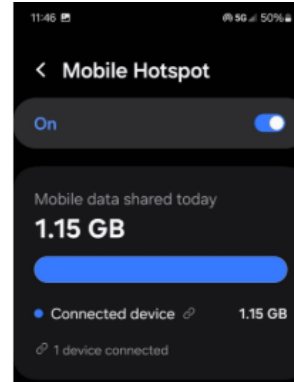

See <https://eu.community.samsung.com/t5/galaxy-z-fold-z-flip/how-do-i-stop-the-hotspot-from-turning-off-automatically-on-z/td-p/10411303>

The Accused Hotspot Instrumentalities can use the intelligent Wi-Fi feature to perform provisioning and monitoring of bandwidth through traffic shaping (e.g., prioritize real-time data and Wi-Fi power saving mode to restrict data usage) and delay provisioning of relayed transmissions (e.g., Wi-Fi power saving mode buffer packets for batch transmissions) For example, the prioritize real-time data mode can prioritize video call applications to reduce jitter and improve call or video clarity. See the image of an Accused Hotspot Instrumentality below.

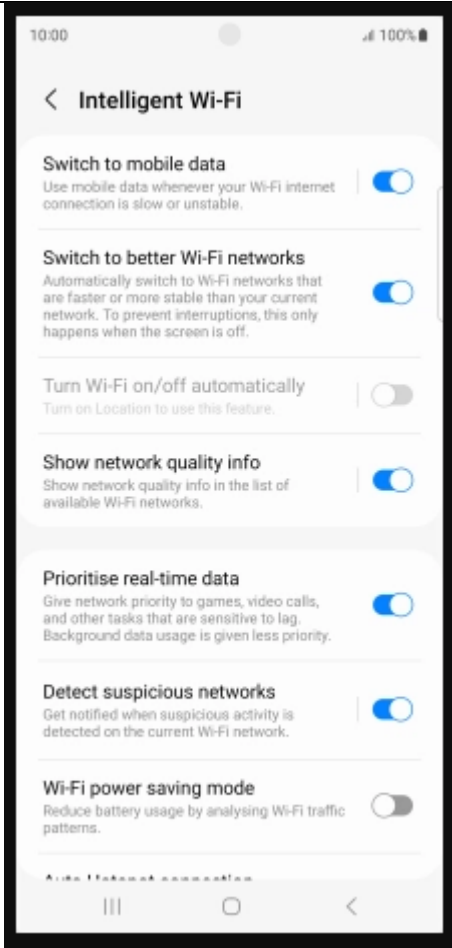
	 <p>See https://deviceguides.vodafone.co.uk/samsung/galaxy-s23-ultra-android-13/troubleshooting/connectivity/my-phone-uses-a-large-amount-of-mobile-data/196/</p>
<p>Claim 11</p>	<p>Accused Hotspot Instrumentalities</p>
<p>11. The broadband wireless repeater or relay of claim 1, wherein said at least one</p>	<p>The receiver and/or the transmitter of the Accused Hotspot Instrumentalities are configured to transmit or receive signals in half-duplex signal modulation through Wi-</p>

<p>receiver or transceiver for receiving signals or data and said at least one transmitter or transceiver for transmitting signals or data operate in half duplex.</p>	<p>Fi networks (e.g., Wi-Fi 5/802.11ac, Wi-Fi 6/802.11ax, or Wi-Fi 6E/ 802.11ax networks) and/or cellular networks (e.g., 4G LTE or 5G).</p>
<p>Claim 17</p>	<p>Accused Instrumentalities</p>
<p>[17] The broadband wireless repeater or relay of claim 1, wherein said repeater or relay employs MIMO or adaptive antenna technology.</p>	<p>The Accused Hotspot Instrumentalities employ MIMO technology and/or adaptive antenna technology for cellular connections and/or Wi-Fi connections. See e.g., https://r2.community.samsung.com/t5/Tech-Talk/What-is-4-4-MIMO-and-Does-My-Smartphone-Need-It/td-p/4938055</p> <p>The Accused Hotspot Instrumentalities include transmitters and receivers to support at least 2x2 SU-MIMO (single user). In Wi-Fi networks, IEEE 802.11n (i.e., Wi-Fi 4) introduced SU-MIMO support for up to 4x4 MIMO, while both 802.11ac (i.e., Wi-Fi 5) and 802.11ax (i.e., Wi-Fi 6/6E) support up to 8x8 SU-MIMO. In Cellular networks, 4G-LTE supports up to 4x4 SU-MIMO and 5G supports up to 4x4 SU-MIMO /64x64 MU-MIMO.</p> <p>The Accused Hotspot Instrumentalities can employ adaptive antenna technology through at least beamforming, antenna selection, and/or spatial filtering. For example, the Accused Hotspot Instrumentalities can use multiple antennas in MIMO technology to direct wireless RF signals in a specific direction based on information from the controller, select an antenna of multiple antennas to send or receive signals based on signal strength, or use multiple antennas to filter or ignore interference.</p> <p>See https://docs.qualcomm.com/bundle/publicresource/87-27161-1_REV_C_Snapdragon_X75_5G_Modem-RF_System_Product_Brief.pdf</p> <p>See claim element [1H] and claims [8], [9] above.</p>

Claim 26	Accused Hotspot Instrumentalities
<p>26. The broadband wireless repeater or relay of claim 1, wherein said broadband wireless repeater or relay is configured or configurable for monitoring or measuring traffic passed through, received by or transmitted by said broadband wireless repeater or relay.</p>	<p>The Accused Hotspot Instrumentalities are configured or configurable for monitoring or measuring traffic passed through, received by or transmitted by said broadband wireless repeater or relay.</p> <p>See claim [9] above.</p>
Claim 29	Accused Hotspot Instrumentalities
<p>[29PRE] A broadband wireless repeater or relay, comprising:</p>	<p>See claim element [1PRE] above.</p>
<p>[29A] at least one receiver or transceiver for signal or data reception from one or more devices;</p>	<p>See claim element [1A] above.</p>
<p>[29B] at least one transmitter or transceiver for signal or data transmission to one or more devices, wherein the transceiver for signal or data reception and the transceiver for signal or data transmission may be the same or different; and</p>	<p>See claim element [1B] above.</p>
<p>[29C] a controller that is configured or configurable for operation in one or more wireless networks, said controller communicating with said at least one receiver or transceiver for signal or data reception and said at least one transmitter</p>	<p>See claim elements [1C] and [1D] above.</p>

<p>or transceiver for signal or data transmission,</p>	
<p>[29D] wherein at least one of said receiver or transceiver for signal or data reception and said transmitter or transceiver for signal or data transmission either or both transmit and receive at an instantaneous or overall occupied bandwidth of 100 MHz or more or have a data transmission rate of 100 Megabits per second or more,</p>	<p>See claim element [1E] above.</p>
<p>[29E] wherein said repeater or relay employs MIMO or adaptive antenna technology,</p>	<p>See claim [17] above.</p>
<p>[29F] wherein said broadband wireless repeater or relay is used to support connectivity and/or position location capabilities for one or more mobile or portable devices, and</p>	<p>See claim element [1G] above.</p>
<p>[29G] wherein said controller is configured or configurable to perform or for performing at least one of: a) ignore or filter out at least some signal or data transmissions from one or more undesired transmitters, users, networks, data sources, or noise sources; and b) instruct one or more devices or networks to ignore or disregard at least some signal or data transmissions of one or more undesired transmitters, undesired</p>	<p>See claim element [1H] above and claim [17] above.</p>

users, undesired networks, or noise sources.	
Claim 30	Accused Hotspot Instrumentalities
30. The broadband wireless repeater or relay of claim 29, wherein said controller is configured or configurable to perform a).	See claim [6] above.
Claim 32	Accused Hotspot Instrumentalities
32. The broadband wireless repeater or relay of claim 29, wherein said controller is configured or configurable to perform network provisioning or monitoring.	See claim [8] above.
Claim 33	Accused Hotspot Instrumentalities
33. The broadband wireless repeater or relay of claim 32, wherein the network provisioning or monitoring includes one or more of: i) bandwidth or delay provisioning of repeated or relayed transmissions, ii) application prioritization, iii) prioritizing, delaying or altering of data transmissions, traffic, or bandwidth, and iv) monitoring or measuring traffic from one or more devices, users or networks.	See claim [9] above.

Claim 35	Accused Hotspot Instrumentalities
35. The broadband wireless repeater or relay of claim 29, wherein said at least one receiver or transceiver for receiving signals or data and said at least one transmitter or transceiver for transmitting signals or data operate in half duplex.	See claim [11] above.
Claim 48	Accused Hotspot Instrumentalities
48. The broadband wireless repeater or relay of claim 29, wherein one or more of said receiver or transceiver for signal or data reception, said transmitter or transceiver for signal or data transmission, and said controller is embedded in one or more integrated circuit chips.	<p>The controller, transmitter, receiver, and/or transceiver of the Accused Hotspot Instrumentalities is embedded in one or more integrated circuit chips.</p> <p>For example, the transmitter, receiver, and/or transceiver is shown by the Wi-Fi module (e.g., Wi-Fi/BT combo chip) and/or cellular module (e.g., 4G-LTE modem, 5G modem) of the Accused Hotspot Instrumentalities. Additionally, the controller is shown by a processor (e.g., Snapdragon 865 processor).</p> <p>See elements [1A] and [1C] above.</p>
Claim 49	Accused Hotspot Instrumentalities
49. The broadband wireless repeater or relay of claim 29, wherein said broadband wireless repeater or relay is configured or configurable for monitoring or measuring traffic passed through, received by or transmitted by said broadband wireless repeater or relay.	See claim [26] above.