



(12) **United States Patent**
Schakel et al.

(10) **Patent No.:** **US 8,566,516 B2**
(45) **Date of Patent:** **Oct. 22, 2013**

(54) **REFRESH MANAGEMENT OF MEMORY MODULES**

(56) **References Cited**

(75) Inventors: **Keith R. Schakel**, San Jose, CA (US);
Suresh Natarajan Rajan, San Jose, CA (US); **Michael John Sebastian Smith**, Palo Alto, CA (US); **David T. Wang**, San Jose, CA (US)

U.S. PATENT DOCUMENTS

3,800,292 A	3/1974	Curley et al.
4,069,452 A	1/1978	Conway et al.
4,323,965 A	4/1982	Johnson et al.
4,334,307 A	6/1982	Bourgeois et al.
4,345,319 A	8/1982	Bernardini et al.
4,392,212 A	7/1983	Miyasaka et al. 365/230
4,525,921 A	7/1985	Carson et al.
4,566,082 A	1/1986	Anderson

(73) Assignee: **Google Inc.**, Mountain View, CA (US)

(*) Notice: Subject to any disclaimer, the term of this patent is extended or adjusted under 35 U.S.C. 154(b) by 655 days.

(Continued)

(21) Appl. No.: **11/929,631**

FOREIGN PATENT DOCUMENTS

DE	102004051345	5/2006
DE	102004053316	5/2006

(22) Filed: **Oct. 30, 2007**

(Continued)

(65) **Prior Publication Data**

US 2008/0109597 A1 May 8, 2008

OTHER PUBLICATIONS

Non-final Office Action from U.S. Appl. No. 11/461,430 mailed on Feb. 19, 2009.

Related U.S. Application Data

(Continued)

(63) Continuation of application No. 11/828,181, filed on Jul. 25, 2007, which is a continuation-in-part of application No. 11/584,179, filed on Oct. 20, 2006, now Pat. No. 7,581,127, which is a continuation of application No. 11/524,811, filed on Sep. 20, 2006, now Pat. No. 7,590,796, which is a continuation-in-part of application No. 11/461,439, filed on Jul. 31, 2006, now Pat. No. 7,580,312.

Primary Examiner — Kenneth Lo
(74) *Attorney, Agent, or Firm* — Fish & Richardson P.C.

(60) Provisional application No. 60/823,229, filed on Aug. 22, 2006.

(57) **ABSTRACT**

One embodiment sets forth an interface circuit configured to manage refresh command sequences that includes a system interface adapted to receive a refresh command from a memory controller, clock frequency detection circuitry configured to determine the timing for issuing staggered refresh commands to two or more memory devices coupled to the interface circuit based on the refresh command received from the memory controller, and at least two refresh command sequence outputs configured to generate the staggered refresh commands for the two or more memory devices.

(51) **Int. Cl.**
G06F 13/12 (2006.01)

(52) **U.S. Cl.**
USPC 711/106; 711/173; 711/E12.001

(58) **Field of Classification Search**
USPC 711/106, 173
See application file for complete search history.

24 Claims, 18 Drawing Sheets

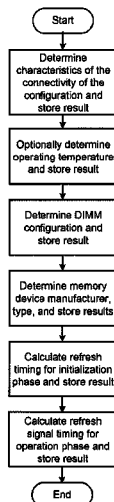

(56)

References Cited

U.S. PATENT DOCUMENTS

4,592,019	A	5/1986	Huang et al.	5,661,677	A	8/1997	Rondeau et al.
4,646,128	A	2/1987	Carson et al.	5,661,695	A	8/1997	Zagar et al.
4,698,748	A	10/1987	Juzswik et al.	5,668,773	A	9/1997	Zagar et al.
4,706,166	A	11/1987	Go	5,675,549	A	10/1997	Ong et al.
4,710,903	A	12/1987	Hereth et al.	5,680,342	A	10/1997	Frankeny
4,764,846	A	8/1988	Go	5,682,354	A	10/1997	Manning
4,780,843	A	10/1988	Tietjen	5,692,121	A	11/1997	Bozso et al.
4,794,597	A	12/1988	Ooba et al.	5,692,202	A	11/1997	Kardach et al.
4,796,232	A	1/1989	House 365/189	5,696,732	A	12/1997	Zagar et al.
4,807,191	A	2/1989	Flannagan	5,696,929	A	12/1997	Hasbun et al.
4,841,440	A	6/1989	Yonezu et al.	5,702,984	A	12/1997	Bertin et al.
4,862,347	A	8/1989	Rudy	5,703,813	A	12/1997	Manning et al.
4,884,237	A	11/1989	Mueller et al.	5,706,247	A	1/1998	Merritt et al.
4,887,240	A	12/1989	Garverick et al. 361/222	RE35,733	E	2/1998	Hernandez et al.
4,888,687	A	12/1989	Allison et al.	5,717,654	A	2/1998	Manning
4,899,107	A	2/1990	Corbett et al.	5,721,859	A	2/1998	Manning
4,912,678	A	3/1990	Mashiko 365/222	5,724,288	A	3/1998	Cloud et al.
4,922,451	A	5/1990	Lo et al.	5,729,503	A	3/1998	Manning
4,935,734	A	6/1990	Austin	5,729,504	A	3/1998	Cowles 365/236
4,937,791	A	6/1990	Steele et al.	5,742,792	A	4/1998	Yanai et al.
4,956,694	A	9/1990	Eide	5,748,914	A	5/1998	Barth et al.
4,982,265	A	1/1991	Watanabe et al.	5,752,045	A	5/1998	Chen
4,983,533	A	1/1991	Go	5,757,703	A	5/1998	Merritt et al.
5,025,364	A	6/1991	Zellmer	5,760,478	A	6/1998	Bozso et al.
5,072,424	A	12/1991	Brent et al. 365/189	5,761,703	A	6/1998	Bolyn 711/106
5,083,266	A	1/1992	Watanabe	5,781,766	A	7/1998	Davis
5,104,820	A	4/1992	Go et al.	5,787,457	A	7/1998	Miller et al.
5,193,072	A	3/1993	Frenkil et al.	5,798,961	A	8/1998	Heyden et al.
5,212,666	A	5/1993	Takeda	5,802,010	A	9/1998	Zagar et al.
5,220,672	A	6/1993	Nakao et al.	5,802,395	A	9/1998	Connolly et al.
5,222,014	A	6/1993	Lin	5,802,555	A	9/1998	Shigeeda 711/106
5,241,266	A	8/1993	Ahmad et al.	5,812,488	A	9/1998	Zagar et al.
5,252,807	A	10/1993	Chizinsky	5,819,065	A	10/1998	Chilton et al.
5,257,233	A	10/1993	Schaefer	5,831,833	A	11/1998	Shirakawa et al.
5,278,796	A	1/1994	Tillinghast et al.	5,831,931	A	11/1998	Manning
5,282,177	A	1/1994	McLaury	5,831,932	A	11/1998	Merritt et al.
5,332,922	A	7/1994	Oguchi et al. 257/723	5,834,838	A	11/1998	Anderson
5,347,428	A	9/1994	Carson et al.	5,835,435	A	11/1998	Bogin et al.
5,369,749	A	11/1994	Baker et al.	5,838,165	A	11/1998	Chatter
5,384,745	A	1/1995	Konishi et al.	5,838,177	A	11/1998	Keeth
5,388,265	A	2/1995	Volk	5,841,580	A	11/1998	Farmwald et al. 365/194
5,390,334	A	2/1995	Harrison	5,843,799	A	12/1998	Hsu et al. 438/6
5,392,251	A	2/1995	Manning	5,843,807	A	12/1998	Burns
5,408,190	A	4/1995	Wood et al.	5,845,108	A	12/1998	Yoo et al.
5,432,729	A	7/1995	Carson et al.	5,850,368	A	12/1998	Ong et al.
5,448,511	A	9/1995	Paurus et al.	5,859,792	A	1/1999	Rondeau et al.
5,467,455	A	11/1995	Gay et al.	5,860,106	A	1/1999	Domen et al.
5,483,497	A	1/1996	Mochizuki et al.	5,870,347	A	2/1999	Keeth et al.
5,498,886	A	3/1996	Hsu et al. 257/213	5,870,350	A	2/1999	Bertin et al.
5,502,333	A	3/1996	Bertin et al.	5,872,907	A	2/1999	Griess et al.
5,502,667	A	3/1996	Bertin et al.	5,875,142	A	2/1999	Chevallier
5,513,135	A	4/1996	Dell et al.	5,878,279	A	3/1999	Athenes
5,513,339	A	4/1996	Agrawal et al.	5,884,088	A	3/1999	Kardach et al.
5,519,832	A	5/1996	Warchol	5,901,105	A	5/1999	Ong et al.
5,526,320	A	6/1996	Zagar et al.	5,903,500	A	5/1999	Tsang et al.
5,530,836	A	6/1996	Busch et al.	5,905,688	A	5/1999	Park
5,550,781	A	8/1996	Sugawara et al.	5,907,512	A	5/1999	Parkinson et al.
5,559,990	A	9/1996	Cheng et al.	5,910,010	A	6/1999	Nishizawa et al.
5,561,622	A	10/1996	Bertin et al.	5,915,105	A	6/1999	Farmwald et al.
5,563,086	A	10/1996	Bertin et al.	5,915,167	A	6/1999	Leedy
5,566,344	A	10/1996	Hall et al.	5,917,758	A	6/1999	Keeth
5,581,498	A	12/1996	Ludwig et al.	5,923,611	A	7/1999	Ryan
5,581,779	A	12/1996	Hall et al.	5,924,111	A	7/1999	Huang et al.
5,590,071	A	12/1996	Kolor et al.	5,926,435	A	7/1999	Park et al.
5,598,376	A	1/1997	Merritt et al.	5,929,650	A	7/1999	Pappert et al.
5,604,714	A	2/1997	Manning et al.	5,943,254	A	8/1999	Bakeman, Jr. et al.
5,606,710	A	2/1997	Hall et al.	5,946,265	A	8/1999	Cowles
5,608,262	A	3/1997	Degani et al.	5,949,254	A	9/1999	Keeth
5,610,864	A	3/1997	Manning	5,953,215	A	9/1999	Karabatsos
5,623,686	A	4/1997	Hall et al.	5,953,263	A	9/1999	Farmwald et al.
5,627,791	A	5/1997	Wright et al.	5,954,804	A	9/1999	Farmwald et al.
5,640,337	A	6/1997	Huang et al.	5,956,233	A	9/1999	Yew et al.
5,640,364	A	6/1997	Merritt et al.	5,963,429	A	10/1999	Chen
5,652,724	A	7/1997	Manning	5,963,463	A	10/1999	Rondeau et al.
5,654,204	A	8/1997	Anderson	5,963,464	A	10/1999	Dell et al.
				5,963,504	A	10/1999	Manning
				5,966,724	A	10/1999	Ryan
				5,966,727	A	10/1999	Nishino
				5,969,996	A	10/1999	Muranaka et al. 365/189.01

(56)

References Cited

U.S. PATENT DOCUMENTS

5,973,392	A	10/1999	Senba et al.	6,327,664	B1	12/2001	Dell et al.
5,978,304	A	11/1999	Crafts	6,330,683	B1	12/2001	Jeddeloh
5,995,424	A	11/1999	Lawrence et al.	6,336,174	B1	1/2002	Li et al.
5,995,443	A	11/1999	Farmwald et al.	6,338,108	B1	1/2002	Motomura
6,001,671	A	12/1999	Fjelstad	6,338,113	B1	1/2002	Kubo et al.
6,002,613	A	12/1999	Cloud et al.	6,341,347	B1	1/2002	Joy et al. 712/228
6,002,627	A	12/1999	Chevallier	6,343,019	B1	1/2002	Jiang et al.
6,014,339	A	1/2000	Kobayashi et al.	6,343,042	B1	1/2002	Tsern et al. 365/222
6,016,282	A	1/2000	Keeth	6,353,561	B1	3/2002	Funyu et al.
6,026,027	A	2/2000	Terrell, II et al.	6,356,105	B1	3/2002	Volk
6,026,050	A	2/2000	Baker et al. 365/233	6,356,500	B1	3/2002	Cloud et al.
6,029,250	A	2/2000	Keeth 713/400	6,362,656	B2	3/2002	Rhee
6,032,214	A	2/2000	Farmwald et al.	6,363,031	B2	3/2002	Phelan
6,032,215	A	2/2000	Farmwald et al.	6,378,020	B2	4/2002	Farmwald et al.
6,034,916	A	3/2000	Lee	6,381,188	B1	4/2002	Choi et al.
6,034,918	A	3/2000	Farmwald et al.	6,381,668	B1	4/2002	Lunteren
6,035,365	A	3/2000	Farmwald et al.	6,389,514	B1	5/2002	Rokicki
6,038,195	A	3/2000	Farmwald et al.	6,392,304	B1	5/2002	Butler
6,038,673	A	3/2000	Benn et al.	6,414,868	B1	7/2002	Wong et al. 365/51
6,044,032	A	3/2000	Li	6,418,034	B1	7/2002	Weber et al.
6,047,073	A	4/2000	Norris et al.	6,421,754	B1 *	7/2002	Kau et al. 710/261
6,047,344	A	4/2000	Kawasumi et al.	6,424,532	B2	7/2002	Kawamura
6,047,361	A	4/2000	Ingenio et al.	6,426,916	B2	7/2002	Farmwald et al.
6,053,948	A	4/2000	Vaidyanathan et al. 703/14	6,429,029	B1	8/2002	Eldridge et al.
6,058,451	A	5/2000	Bermingham et al.	6,430,103	B2	8/2002	Nakayama et al.
6,065,092	A	5/2000	Roy	6,434,660	B1	8/2002	Lambert et al.
6,069,504	A	5/2000	Keeth	6,437,600	B1	8/2002	Keeth
6,070,217	A	5/2000	Connolly et al.	6,438,057	B1 *	8/2002	Ruckerbauer 365/222
6,073,223	A	6/2000	McAllister et al.	6,442,698	B2	8/2002	Nizar
6,075,730	A	6/2000	Barth et al.	6,445,591	B1	9/2002	Kwong
6,075,744	A	6/2000	Tsern et al. 365/230	6,452,826	B1	9/2002	Kim et al.
6,078,546	A	6/2000	Lee	6,452,863	B2	9/2002	Farmwald et al.
6,079,025	A	6/2000	Fung	6,453,400	B1	9/2002	Maesako et al.
6,084,434	A	7/2000	Keeth	6,453,402	B1	9/2002	Jeddeloh 711/167
6,088,290	A	7/2000	Ohtake et al.	6,453,434	B2	9/2002	Delp et al.
6,091,251	A	7/2000	Wood et al.	6,455,348	B1	9/2002	Yamaguchi
RE36,839	E	8/2000	Simmons et al.	6,457,095	B1	9/2002	Volk
6,101,152	A	8/2000	Farmwald et al.	6,459,651	B1	10/2002	Lee et al.
6,101,564	A	8/2000	Athenes et al.	6,473,831	B1	10/2002	Schade
6,101,612	A	8/2000	Jeddeloh	6,476,476	B1	11/2002	Glenn
6,108,795	A	8/2000	Jeddeloh	6,480,929	B1	11/2002	Gauthier et al.
6,111,812	A	8/2000	Gans et al. 365/233	6,487,102	B1	11/2002	Halbert et al.
6,134,638	A	10/2000	Olarig et al. 711/167	6,489,669	B2	12/2002	Shimada et al.
6,154,370	A	11/2000	Degani et al.	6,490,161	B1	12/2002	Johnson
6,166,991	A	12/2000	Phelan	6,492,726	B1	12/2002	Quek et al.
6,181,640	B1	1/2001	Kang	6,493,789	B2	12/2002	Ware et al.
6,182,184	B1	1/2001	Farmwald et al.	6,496,440	B2	12/2002	Manning
6,199,151	B1	3/2001	Williams et al.	6,496,897	B2	12/2002	Ware et al.
6,208,168	B1	3/2001	Rhee	6,498,766	B2	12/2002	Lee et al. 365/233
6,216,246	B1	4/2001	Shau 714/763	6,510,097	B2	1/2003	Fukuyama
6,222,739	B1	4/2001	Bhakta et al.	6,510,503	B2	1/2003	Gillingham et al.
6,226,709	B1	5/2001	Goodwin et al.	6,512,392	B2	1/2003	Fleury et al.
6,226,730	B1	5/2001	Murdoch et al.	6,521,984	B2	2/2003	Matsuura
6,233,192	B1	5/2001	Tanaka	6,526,471	B1	2/2003	Shimomura et al.
6,233,650	B1	5/2001	Johnson et al.	6,526,473	B1	2/2003	Kim
6,240,048	B1	5/2001	Matsubara	6,526,484	B1	2/2003	Stacovsky et al.
6,243,282	B1	6/2001	Rondeau et al.	6,545,895	B1	4/2003	Li et al.
6,252,807	B1	6/2001	Suzuki et al.	6,546,446	B2	4/2003	Farmwald et al.
6,253,278	B1	6/2001	Ryan	6,553,450	B1	4/2003	Dodd et al.
6,260,097	B1	7/2001	Farmwald et al.	6,560,158	B2	5/2003	Choi et al.
6,260,154	B1	7/2001	Jeddeloh	6,563,337	B2	5/2003	Dour
6,262,938	B1	7/2001	Lee et al.	6,563,759	B2	5/2003	Yahata et al.
6,266,285	B1	7/2001	Farmwald et al.	6,564,281	B2	5/2003	Farmwald et al.
6,266,292	B1	7/2001	Tsern et al. 365/230	6,564,285	B1	5/2003	Mills et al. 711/103
6,274,395	B1	8/2001	Weber	6,574,150	B2	6/2003	Suyama et al.
6,279,069	B1	8/2001	Robinson et al. 711/103	6,584,037	B2	6/2003	Farmwald et al.
6,295,572	B1	9/2001	Wu	6,587,912	B2	7/2003	Leddige et al.
6,298,426	B1	10/2001	Ajanovic	6,590,822	B2	7/2003	Hwang et al.
6,304,511	B1	10/2001	Gans et al. 365/233	6,594,770	B1	7/2003	Sato et al.
6,307,769	B1	10/2001	Nuxoll et al.	6,597,616	B2	7/2003	Tsern et al. 365/222
6,314,051	B1	11/2001	Farmwald et al.	6,597,617	B2	7/2003	Ooishi et al.
6,317,352	B1	11/2001	Halbert et al. 365/52	6,614,700	B2	9/2003	Dietrich et al.
6,317,381	B1	11/2001	Gans et al. 365/233	6,618,267	B1	9/2003	Dalal et al.
6,324,120	B2	11/2001	Farmwald et al.	6,618,791	B1	9/2003	Dodd et al.
6,326,810	B1	12/2001	Keeth	6,621,760	B1	9/2003	Ahmad et al.
				6,628,538	B2	9/2003	Funaba et al.
				6,630,729	B2	10/2003	Huang
				6,631,086	B1	10/2003	Bill et al.
				6,639,820	B1	10/2003	Khandekar et al.

(56)

References Cited

U.S. PATENT DOCUMENTS

6,646,939	B2	11/2003	Kwak		6,930,900	B2	8/2005	Bhakta et al.
6,650,588	B2	11/2003	Yamagata	365/222	6,930,903	B2	8/2005	Bhakta et al.
6,650,594	B1	11/2003	Lee et al.		6,938,119	B2	8/2005	Kohn et al.
6,657,634	B1	12/2003	Sinclair et al.		6,943,450	B2	9/2005	Fee et al.
6,657,918	B2	12/2003	Foss et al.		6,944,748	B2	9/2005	Sanches et al.
6,657,919	B2	12/2003	Foss et al.		6,947,341	B2	9/2005	Stubbs et al.
6,658,016	B1	12/2003	Dai et al.		6,951,982	B2	10/2005	Chye et al.
6,658,530	B1	12/2003	Robertson et al.		6,952,794	B2	10/2005	Lu
6,659,512	B1	12/2003	Harper et al.		6,961,281	B2	11/2005	Wong et al.
6,664,625	B2	12/2003	Hiruma		6,968,416	B2	11/2005	Moy
6,665,224	B1	12/2003	Lehmann et al.		6,968,419	B1	11/2005	Holman
6,665,227	B2	12/2003	Fetzer		6,970,968	B1	11/2005	Holman
6,668,242	B1	12/2003	Reynov et al.		6,980,021	B1	12/2005	Srivastava et al. 326/30
6,674,154	B2	1/2004	Minamio et al.		6,986,118	B2	1/2006	Dickman
6,683,372	B1	1/2004	Wong et al.		6,992,501	B2	1/2006	Rapport
6,684,292	B2	1/2004	Piccirillo et al.		6,992,950	B2	1/2006	Foss et al.
6,690,191	B2	2/2004	Wu et al.		7,000,062	B2	2/2006	Perego et al.
6,697,295	B2	2/2004	Farmwald et al.		7,003,618	B2	2/2006	Perego et al.
6,701,446	B2	3/2004	Tsern et al.		7,003,639	B2	2/2006	Tsern et al.
6,705,877	B1	3/2004	Li et al.		7,007,095	B2	2/2006	Chen et al.
6,708,144	B1	3/2004	Merryman et al.		7,007,175	B2	2/2006	Chang et al.
6,710,430	B2	3/2004	Minamio et al.		7,010,642	B2	3/2006	Perego et al.
6,711,043	B2	3/2004	Friedman et al.		7,010,736	B1	3/2006	Teh et al.
6,713,856	B2	3/2004	Tsai et al.		7,024,518	B2	4/2006	Halbert et al. 711/115
6,714,891	B2	3/2004	Dendinger		7,026,708	B2	4/2006	Cady et al.
6,724,684	B2	4/2004	Kim		7,028,215	B2	4/2006	Depew et al.
6,730,540	B2	5/2004	Siniaguine		7,028,234	B2	4/2006	Huckaby et al.
6,731,009	B1	5/2004	Jones et al.		7,033,861	B1	4/2006	Partridge et al.
6,731,527	B2	5/2004	Brown	365/63	7,035,150	B2	4/2006	Streif et al.
6,742,098	B1	5/2004	Halbert et al.		7,043,599	B1	5/2006	Ware et al. 711/106
6,744,687	B2	6/2004	Koo et al.		7,043,611	B2	5/2006	McClannahan et al.
6,747,887	B2	6/2004	Halbert et al.		7,045,396	B2	5/2006	Crowley et al.
6,751,113	B2	6/2004	Bhakta et al.		7,045,901	B2	5/2006	Lin et al.
6,751,696	B2	6/2004	Farmwald et al.		7,046,538	B2	5/2006	Kinsley et al.
6,754,129	B2	6/2004	Khatri et al.		7,053,470	B1	5/2006	Sellers et al.
6,754,132	B2	6/2004	Kyung		7,053,478	B2	5/2006	Roper et al.
6,757,751	B1	6/2004	Gene		7,058,776	B2	6/2006	Lee 711/167
6,762,948	B2	7/2004	Kyun et al.		7,058,863	B2	6/2006	Kouchi et al.
6,765,812	B2	7/2004	Anderson		7,061,784	B2	6/2006	Jakobs et al.
6,766,469	B2	7/2004	Larson et al.		7,061,823	B2	6/2006	Faue et al.
6,771,526	B2	8/2004	LaBerge		7,066,741	B2	6/2006	Burns et al.
6,772,359	B2	8/2004	Kwak et al.		7,075,175	B2	7/2006	Kazi et al.
6,779,097	B2	8/2004	Gillingham et al.		7,079,396	B2	7/2006	Gates et al.
6,785,767	B2	8/2004	Coulson		7,079,441	B1	7/2006	Partsch et al.
6,791,877	B2	9/2004	Miura et al.		7,079,446	B2	7/2006	Murtagh et al.
6,795,899	B2	9/2004	Dodd et al.		7,085,152	B2	8/2006	Ellis et al. 365/149
6,799,241	B2	9/2004	Kahn et al.		7,085,941	B2	8/2006	Li
6,801,989	B2	10/2004	Johnson et al. 711/167		7,089,438	B2	8/2006	Raad
6,807,598	B2	10/2004	Farmwald et al.		7,093,101	B2	8/2006	Aasheim et al.
6,807,650	B2	10/2004	Lamb et al.		7,103,730	B2	9/2006	Saxena et al.
6,807,655	B1	10/2004	Rehani et al.		7,110,322	B2	9/2006	Farmwald et al.
6,816,991	B2	11/2004	Sanghani		7,111,143	B2	9/2006	Walker
6,819,602	B2	11/2004	Seo et al.		7,117,309	B2	10/2006	Bearden
6,819,617	B2	11/2004	Hwang et al.		7,119,428	B2	10/2006	Tanie et al.
6,820,163	B1	11/2004	McCall et al.		7,120,727	B2	10/2006	Lee et al. 711/5
6,820,169	B2	11/2004	Wilcox et al.		7,126,399	B1	10/2006	Lee
6,826,104	B2	11/2004	Kawaguchi et al.		7,127,567	B2	10/2006	Ramakrishnan et al.
6,839,290	B2	1/2005	Ahmad et al.		7,133,960	B1	11/2006	Thompson et al. 711/5
6,845,027	B2	1/2005	Mayer et al.		7,136,978	B2	11/2006	Miura et al.
6,845,055	B1	1/2005	Koga et al.		7,138,823	B2	11/2006	Janzen et al.
6,847,582	B2	1/2005	Pan		7,149,145	B2	12/2006	Kim et al. 365/233
6,850,449	B2	2/2005	Takahashi		7,149,824	B2	12/2006	Johnson
6,854,043	B2	2/2005	Hargis et al.		7,173,863	B2	2/2007	Conley et al.
6,862,202	B2	3/2005	Schaefer		7,200,021	B2	4/2007	Raghuram 365/51
6,862,249	B2	3/2005	Kyung		7,205,789	B1	4/2007	Karabatsos
6,862,653	B1	3/2005	Dodd et al.		7,210,059	B2	4/2007	Jeddeloh
6,873,534	B2	3/2005	Bhakta et al.		7,215,561	B2	5/2007	Park et al.
6,878,570	B2	4/2005	Lyu et al.		7,218,566	B1	5/2007	Totolos, Jr. et al.
6,894,933	B2	5/2005	Kuzmenka et al.		7,224,595	B2	5/2007	Dreps et al. 365/63
6,898,683	B2	5/2005	Nakamura		7,228,264	B2	6/2007	Barrenscheen et al.
6,908,314	B2	6/2005	Brown		7,231,562	B2	6/2007	Ohlhoff et al.
6,912,778	B2	7/2005	Ahn et al.		7,233,541	B2	6/2007	Yamamoto et al. 365/230.03
6,914,786	B1	7/2005	Paulsen et al.		7,234,081	B2	6/2007	Nguyen et al.
6,917,219	B2	7/2005	New 326/41		7,243,185	B2	7/2007	See et al.
6,922,371	B2	7/2005	Takahashi et al.		7,245,541	B2	7/2007	Janzen
					7,254,036	B2	8/2007	Pauley et al. 361/721
					7,266,639	B2	9/2007	Raghuram 711/115
					7,269,042	B2	9/2007	Kinsley et al. 365/52
					7,269,708	B2	9/2007	Ware

(56)

References Cited

U.S. PATENT DOCUMENTS

7,274,583	B2	9/2007	Park et al.		2002/0124195	A1	9/2002	Nizar	
7,277,333	B2	10/2007	Schaefer		2002/0129204	A1	9/2002	Leighnor et al.	
7,286,436	B2	10/2007	Bhakta et al.	365/230	2002/0145900	A1	10/2002	Schaefer	
7,289,386	B2	10/2007	Bhakta et al.		2002/0165706	A1	11/2002	Raynham	703/25
7,296,754	B2	11/2007	Nishizawa et al.	235/492	2002/0167092	A1	11/2002	Fee et al.	
7,299,330	B2	11/2007	Gillingham et al.		2002/0172024	A1	11/2002	Hui et al.	
7,302,598	B2	11/2007	Suzuki et al.		2002/0174274	A1	11/2002	Wu et al.	
7,307,863	B2	12/2007	Yen et al.	365/63	2002/0184438	A1	12/2002	Usui	
7,317,250	B2	1/2008	Koh et al.		2003/0002262	A1	1/2003	Benisek et al.	
7,327,613	B2	2/2008	Lee		2003/0011993	A1	1/2003	Summers et al.	
7,337,293	B2	2/2008	Brittain et al.		2003/0016550	A1	1/2003	Yoo et al.	
7,363,422	B2	4/2008	Perego et al.	711/105	2003/0021175	A1	1/2003	Tae Kwak	
7,366,947	B2	4/2008	Gower et al.		2003/0026155	A1*	2/2003	Yamagata	365/222
7,379,316	B2	5/2008	Rajan		2003/0026159	A1	2/2003	Frankowsky et al.	
7,386,656	B2	6/2008	Rajan et al.		2003/0035312	A1	2/2003	Halbert et al.	
7,392,338	B2	6/2008	Rajan et al.		2003/0039158	A1	2/2003	Horiguchi et al.	
7,408,393	B1	8/2008	Jain et al.	327/202	2003/0041295	A1	2/2003	Hou et al.	
7,409,492	B2	8/2008	Tanaka et al.	711/103	2003/0061458	A1	3/2003	Wilcox et al.	
7,414,917	B2	8/2008	Ruckerbauer et al.		2003/0061459	A1	3/2003	Aboulenein et al.	
7,428,644	B2	9/2008	Jeddeloh et al.		2003/0083855	A1	5/2003	Fukuyama	
7,437,579	B2	10/2008	Jeddeloh et al.	713/300	2003/0088743	A1	5/2003	Rader	
7,441,064	B2	10/2008	Gaskins		2003/0093614	A1	5/2003	Kohn et al.	
7,457,122	B2	11/2008	Lai et al.		2003/0101392	A1	5/2003	Lee	
7,464,225	B2	12/2008	Tsern	711/115	2003/0105932	A1	6/2003	David et al.	
7,472,220	B2	12/2008	Rajan et al.	711/103	2003/0110339	A1	6/2003	Calvignac et al.	
7,474,576	B2	1/2009	Co et al.		2003/0117875	A1	6/2003	Lee et al.	
7,480,147	B2	1/2009	Hoss et al.		2003/0123389	A1	7/2003	Russell et al.	
7,480,774	B2	1/2009	Ellis et al.		2003/0126338	A1	7/2003	Dodd et al.	
7,496,777	B2	2/2009	Kapil	713/324	2003/0127737	A1	7/2003	Takahashi	
7,515,453	B2	4/2009	Rajan	365/63	2003/0131160	A1	7/2003	Hampel et al.	
7,532,537	B2	5/2009	Solomon et al.	365/230	2003/0145163	A1	7/2003	Seo et al.	711/106
7,539,800	B2	5/2009	Dell et al.		2003/0158995	A1	8/2003	Lee et al.	
7,573,136	B2	8/2009	Jiang et al.		2003/0164539	A1	9/2003	Yau	
7,580,312	B2	8/2009	Rajan et al.		2003/0164543	A1	9/2003	Kheng Lee	
7,581,121	B2	8/2009	Barth et al.		2003/0174569	A1	9/2003	Amidi	
7,581,127	B2	8/2009	Rajan et al.		2003/0182513	A1	9/2003	Dodd et al.	
7,590,796	B2	9/2009	Rajan et al.		2003/0183934	A1	10/2003	Barrett	
7,599,205	B2	10/2009	Rajan		2003/0189868	A1	10/2003	Riesenman et al.	
7,606,245	B2	10/2009	Ma et al.		2003/0189870	A1	10/2003	Wilcox	
7,609,567	B2	10/2009	Rajan et al.		2003/0191888	A1	10/2003	Klein	
7,613,880	B2	11/2009	Miura et al.		2003/0191915	A1	10/2003	Saxena et al.	
7,619,912	B2	11/2009	Bhakta et al.		2003/0200382	A1	10/2003	Wells et al.	
7,724,589	B2	5/2010	Rajan et al.		2003/0200474	A1	10/2003	Li	
7,730,338	B2	6/2010	Rajan et al.		2003/0205802	A1	11/2003	Segaram et al.	
7,761,724	B2	7/2010	Rajan et al.		2003/0206476	A1	11/2003	Joo	
7,934,070	B2	4/2011	Brittain et al.		2003/0217303	A1	11/2003	Chua-Eoan et al.	
7,990,797	B2	8/2011	Moshayedi et al.		2003/0223290	A1	12/2003	Park et al.	365/200
8,116,144	B2	2/2012	Shaw et al.		2003/0227798	A1	12/2003	Pax	
2001/0000822	A1	5/2001	Dell et al.		2003/0229821	A1	12/2003	Ma	
2001/0003198	A1	6/2001	Wu		2003/0230801	A1	12/2003	Jiang et al.	
2001/0011322	A1*	8/2001	Stolt et al.	711/105	2003/0231540	A1	12/2003	Lazar et al.	
2001/0019509	A1	9/2001	Aho et al.		2003/0231542	A1	12/2003	Zaharinova-Papazova et al.	
2001/0021106	A1	9/2001	Weber et al.		2003/0234664	A1	12/2003	Yamagata	
2001/0021137	A1	9/2001	Kai et al.		2004/0016994	A1	1/2004	Huang	
2001/0046129	A1	11/2001	Broglia et al.		2004/0027902	A1	2/2004	Ooishi et al.	
2001/0046163	A1	11/2001	Yanagawa		2004/0034732	A1	2/2004	Valin et al.	
2001/0052062	A1	12/2001	Lipovski		2004/0034755	A1	2/2004	LaBerge et al.	
2002/0002662	A1	1/2002	Olarig et al.		2004/0037133	A1	2/2004	Park et al.	365/202
2002/0004897	A1	1/2002	Kao et al.		2004/0042503	A1	3/2004	Shaeffer et al.	
2002/0015340	A1	2/2002	Batinovich		2004/0044808	A1	3/2004	Salmon et al.	
2002/0019961	A1	2/2002	Blodgett		2004/0047228	A1	3/2004	Chen	
2002/0034068	A1	3/2002	Weber et al.		2004/0049624	A1	3/2004	Salmonsens	
2002/0038405	A1	3/2002	Leddige et al.		2004/0057317	A1	3/2004	Schaefer	
2002/0040416	A1	4/2002	Tsern et al.		2004/0064647	A1	4/2004	DeWhitt et al.	
2002/0041507	A1	4/2002	Woo et al.		2004/0064767	A1	4/2004	Huckaby et al.	
2002/0051398	A1	5/2002	Mizugaki	365/222	2004/0083324	A1	4/2004	Rabinovitz et al.	
2002/0060945	A1	5/2002	Ikeda		2004/0088475	A1	5/2004	Streif et al.	
2002/0060948	A1	5/2002	Chang et al.		2004/0100837	A1	5/2004	Lee	
2002/0064073	A1	5/2002	Chien		2004/0117723	A1	6/2004	Foss	
2002/0064083	A1	5/2002	Ryu et al.		2004/0123173	A1	6/2004	Emberling et al.	714/733
2002/0089831	A1	7/2002	Forthun		2004/0125635	A1	7/2004	Kuzmenka	
2002/0089970	A1	7/2002	Asada et al.		2004/0133736	A1	7/2004	Kyung	711/105
2002/0094671	A1	7/2002	Distefano et al.		2004/0139359	A1	7/2004	Samson et al.	
2002/0121650	A1	9/2002	Minamio et al.		2004/0145963	A1	7/2004	Byon	
2002/0121670	A1	9/2002	Minamio et al.		2004/0151038	A1	8/2004	Ruckerbauer et al.	
					2004/0174765	A1	9/2004	Seo et al.	
					2004/0177079	A1	9/2004	Gluhovsky et al.	707/100
					2004/0178824	A1	9/2004	Pan	
					2004/0184324	A1	9/2004	Pax	

(56)

References Cited

U.S. PATENT DOCUMENTS

2004/0186956	A1	9/2004	Perego et al.	2005/0283572	A1	12/2005	Ishihara
2004/0188704	A1	9/2004	Halbert et al.	2005/0285174	A1	12/2005	Saito et al.
2004/0195682	A1	10/2004	Kimura	2005/0286334	A1	12/2005	Saito et al.
2004/0196732	A1	10/2004	Lee	2005/0289292	A1	12/2005	Morrow et al.
2004/0205433	A1	10/2004	Gower et al.	2005/0289317	A1	12/2005	Liou et al. 711/170
2004/0208173	A1	10/2004	Di Gregoria	2006/0002201	A1	1/2006	Janzen 365/191
2004/0225858	A1	11/2004	Brueggen	2006/0010339	A1	1/2006	Klein
2004/0228166	A1	11/2004	Braun et al.	2006/0026484	A1	2/2006	Hollums 714/746
2004/0228196	A1	11/2004	Kwak et al.	2006/0038597	A1	2/2006	Becker et al.
2004/0228203	A1	11/2004	Koo	2006/0039204	A1	2/2006	Cornelius
2004/0230932	A1	11/2004	Dickmann	2006/0039205	A1	2/2006	Cornelius
2004/0236877	A1	11/2004	Burton	2006/0041711	A1	2/2006	Miura et al.
2004/0250989	A1	12/2004	Im et al.	2006/0041730	A1	2/2006	Larson
2004/0256638	A1	12/2004	Perego et al.	2006/0044909	A1	3/2006	Kinsley et al. 365/222
2004/0257847	A1	12/2004	Matsui et al.	2006/0044913	A1	3/2006	Klein et al.
2004/0257857	A1	12/2004	Yamamoto et al.	2006/0049502	A1	3/2006	Goodwin et al.
2004/0260957	A1	12/2004	Jeddeloh et al.	2006/0050574	A1	3/2006	Streif et al.
2004/0264255	A1	12/2004	Royer	2006/0056244	A1	3/2006	Ware 365/194
2004/0268161	A1	12/2004	Ross	2006/0062047	A1	3/2006	Bhakta et al.
2005/0018495	A1	1/2005	Bhakta et al.	2006/0067141	A1	3/2006	Perego et al.
2005/0021874	A1	1/2005	Georgiou et al.	2006/0085616	A1	4/2006	Zeighami et al.
2005/0024963	A1	2/2005	Jakobs et al.	2006/0087900	A1	4/2006	Bucksch et al.
2005/0027928	A1	2/2005	Avraham et al. 711/103	2006/0090031	A1	4/2006	Kirshenbaum et al.
2005/0028038	A1	2/2005	Pomaranski et al.	2006/0090054	A1	4/2006	Choi et al.
2005/0034004	A1	2/2005	Bunker et al.	2006/0106951	A1	5/2006	Bains 710/5
2005/0036350	A1	2/2005	So et al.	2006/0112214	A1	5/2006	Yeh
2005/0041504	A1	2/2005	Perego et al.	2006/0112219	A1	5/2006	Chawla et al.
2005/0044302	A1	2/2005	Pauley et al.	2006/0117152	A1	6/2006	Amidi et al. 711/154
2005/0044303	A1	2/2005	Perego et al.	2006/0117160	A1	6/2006	Jackson et al.
2005/0044305	A1	2/2005	Jakobs et al.	2006/0118933	A1	6/2006	Haba
2005/0047192	A1	3/2005	Matsui et al.	2006/0120193	A1	6/2006	Casper
2005/0071543	A1	3/2005	Ellis et al.	2006/0123265	A1	6/2006	Ruckerbauer et al.
2005/0078532	A1	4/2005	Ruckerbauer et al.	2006/0126369	A1	6/2006	Raghuram
2005/0081085	A1	4/2005	Ellis et al.	2006/0129712	A1	6/2006	Raghuram
2005/0086548	A1	4/2005	Haid et al.	2006/0129740	A1	6/2006	Ruckerbauer et al.
2005/0099834	A1	5/2005	Funaba et al.	2006/0129755	A1	6/2006	Raghuram
2005/0102590	A1	5/2005	Norris et al.	2006/0133173	A1	6/2006	Jain et al.
2005/0105318	A1	5/2005	Funaba et al.	2006/0136791	A1	6/2006	Nierle
2005/0108460	A1*	5/2005	David 711/5	2006/0149857	A1	7/2006	Holman
2005/0127531	A1	6/2005	Tay et al.	2006/0149982	A1	7/2006	Vogt
2005/0132158	A1	6/2005	Hampel et al. 711/167	2006/0174082	A1	8/2006	Bellows et al.
2005/0135176	A1	6/2005	Ramakrishnan et al.	2006/0176744	A1	8/2006	Stave
2005/0138267	A1	6/2005	Bains et al.	2006/0179262	A1	8/2006	Brittain et al.
2005/0138304	A1	6/2005	Ramakrishnan et al.	2006/0179333	A1	8/2006	Brittain et al.
2005/0139977	A1	6/2005	Nishio et al.	2006/0179334	A1	8/2006	Brittain et al.
2005/0141199	A1	6/2005	Chiou et al.	2006/0180926	A1	8/2006	Mullen et al.
2005/0149662	A1	7/2005	Perego et al.	2006/0181953	A1	8/2006	Rotenberg et al. 365/230.06
2005/0152212	A1	7/2005	Yang et al.	2006/0195631	A1	8/2006	Rajamani
2005/0156934	A1	7/2005	Perego et al.	2006/0198178	A1	9/2006	Kinsley et al.
2005/0166026	A1	7/2005	Ware et al.	2006/0203590	A1	9/2006	Mori et al.
2005/0193163	A1	9/2005	Perego et al.	2006/0206738	A1	9/2006	Jeddeloh et al.
2005/0193183	A1	9/2005	Barth et al.	2006/0233012	A1	10/2006	Sekiguchi et al.
2005/0194676	A1	9/2005	Fukuda et al.	2006/0236165	A1	10/2006	Cepulis et al.
2005/0194991	A1	9/2005	Dour et al.	2006/0236201	A1	10/2006	Gower et al.
2005/0195629	A1	9/2005	Leddige et al.	2006/0248261	A1	11/2006	Jacob et al.
2005/0201063	A1	9/2005	Lee et al.	2006/0248387	A1	11/2006	Nicholson et al.
2005/0204111	A1	9/2005	Natarajan	2006/0262586	A1	11/2006	Solomon et al.
2005/0207255	A1	9/2005	Perego et al.	2006/0262587	A1	11/2006	Matsui et al.
2005/0210196	A1	9/2005	Perego et al.	2006/0277355	A1	12/2006	Ellsberry et al.
2005/0223179	A1	10/2005	Perego et al.	2006/0294295	A1	12/2006	Fukuzo
2005/0224948	A1	10/2005	Lee et al.	2007/0005998	A1	1/2007	Jain et al.
2005/0232049	A1	10/2005	Park	2007/0050530	A1	3/2007	Rajan 711/5
2005/02335119	A1	10/2005	Sechrest et al.	2007/0058471	A1	3/2007	Rajan et al. 365/222
2005/0235131	A1	10/2005	Ware	2007/0070669	A1	3/2007	Tsern
2005/0237838	A1	10/2005	Kwak et al. 365/222	2007/0088995	A1	4/2007	Tsern et al.
2005/0243635	A1	11/2005	Schaefer	2007/0091696	A1	4/2007	Niggemeier et al.
2005/0246558	A1	11/2005	Ku	2007/0106860	A1	5/2007	Foster et al. 711/170
2005/0249011	A1	11/2005	Maeda	2007/0136537	A1	6/2007	Doblar et al.
2005/0259504	A1	11/2005	Murtugh et al.	2007/0162700	A1	7/2007	Fortin et al.
2005/0263312	A1	12/2005	Bolken et al.	2007/0188997	A1	8/2007	Hockanson et al.
2005/0265506	A1	12/2005	Foss et al.	2007/0192563	A1	8/2007	Rajan et al. 711/202
2005/0269715	A1	12/2005	Yoo	2007/0195613	A1	8/2007	Rajan et al. 365/189.05
2005/0278474	A1	12/2005	Perersen et al.	2007/0204075	A1	8/2007	Rajan et al.
2005/0281096	A1	12/2005	Bhakta et al.	2007/0216445	A1	9/2007	Raghavan et al. 326/83
2005/0281123	A1	12/2005	Bell et al.	2007/0247194	A1	10/2007	Jain 326/87
				2007/0279084	A1	12/2007	Oh et al.
				2007/0288683	A1	12/2007	Panabaker et al.
				2007/0288686	A1	12/2007	Arcedera et al. 711/103
				2007/0288687	A1	12/2007	Panabaker et al.

(56)

References Cited

U.S. PATENT DOCUMENTS

2008/0002447 A1 1/2008 Gulachenski et al.
 2008/0010435 A1 1/2008 Smith et al.
 2008/0025108 A1 1/2008 Rajan et al. 365/189.05
 2008/0025122 A1 1/2008 Schakel et al. 365/222
 2008/0025136 A1 1/2008 Rajan et al. 365/230.08
 2008/0025137 A1 1/2008 Rajan et al. 365/239
 2008/0027697 A1 1/2008 Rajan et al. 703/14
 2008/0027702 A1 1/2008 Rajan et al. 703/21
 2008/0027703 A1 1/2008 Rajan et al. 703/21
 2008/0028135 A1 1/2008 Rajan et al.
 2008/0028136 A1 1/2008 Schakel et al. 711/106
 2008/0028137 A1 1/2008 Schakel et al.
 2008/0031030 A1 2/2008 Rajan et al. 365/63
 2008/0031072 A1 2/2008 Rajan et al. 365/227
 2008/0034130 A1 2/2008 Perego et al.
 2008/0037353 A1 2/2008 Rajan et al. 365/227
 2008/0056014 A1 3/2008 Rajan et al. 365/189.03
 2008/0062773 A1 3/2008 Rajan et al. 365/189.03
 2008/0065820 A1 3/2008 Gillingham et al.
 2008/0082763 A1 4/2008 Rajan et al. 711/154
 2008/0086588 A1 4/2008 Danilak et al.
 2008/0089034 A1 4/2008 Hoss et al.
 2008/0098277 A1 4/2008 Hazelzet
 2008/0103753 A1 5/2008 Rajan et al.
 2008/0104314 A1 5/2008 Rajan et al.
 2008/0109206 A1 5/2008 Rajan et al.
 2008/0109595 A1 5/2008 Rajan et al.
 2008/0109597 A1 5/2008 Schakel et al.
 2008/0109598 A1 5/2008 Schakel et al.
 2008/0115006 A1 5/2008 Smith et al. 713/601
 2008/0120443 A1 5/2008 Rajan et al.
 2008/0120458 A1 5/2008 Gillingham et al.
 2008/0123459 A1 5/2008 Rajan et al. 365/227
 2008/0126624 A1 5/2008 Prete et al.
 2008/0126687 A1 5/2008 Rajan et al.
 2008/0126688 A1 5/2008 Rajan et al.
 2008/0126689 A1 5/2008 Rajan et al.
 2008/0126690 A1 5/2008 Rajan et al. 711/105
 2008/0126692 A1 5/2008 Rajan et al.
 2008/0130364 A1 6/2008 Guterman et al.
 2008/0133825 A1 6/2008 Rajan et al.
 2008/0155136 A1 6/2008 Hishino
 2008/0159027 A1 7/2008 Kim
 2008/0170425 A1 7/2008 Rajan
 2008/0195894 A1 8/2008 Schreck et al.
 2008/0215832 A1 9/2008 Allen et al.
 2008/0239857 A1 10/2008 Rajan et al. 365/227
 2008/0239858 A1 10/2008 Rajan et al. 365/227
 2008/0256282 A1 10/2008 Guo et al.
 2008/0282084 A1 11/2008 Hatakeyama
 2008/0282341 A1 11/2008 Hatakeyama
 2009/0024789 A1 1/2009 Rajan et al.
 2009/0024790 A1 1/2009 Rajan et al.
 2009/0049266 A1 2/2009 Kuhne
 2009/0063865 A1 3/2009 Berenbaum et al.
 2009/0063896 A1 3/2009 Lastras-Montano et al.
 2009/0070520 A1 3/2009 Mizushima
 2009/0089480 A1 4/2009 Wah et al.
 2009/0109613 A1 4/2009 Legen et al.
 2009/0216939 A1 8/2009 Smith et al.
 2009/0285031 A1 11/2009 Rajan et al.
 2009/0290442 A1 11/2009 Rajan
 2010/0005218 A1 1/2010 Gower et al.
 2010/0020585 A1 1/2010 Rajan
 2010/0257304 A1 10/2010 Rajan et al.
 2010/0271888 A1 10/2010 Rajan
 2010/0281280 A1 11/2010 Rajan et al.

FOREIGN PATENT DOCUMENTS

DE 102005036528 2/2007
 EP 0644547 3/1995
 JP 62121978 6/1987
 JP 01-171047 7/1989

JP 03-29357 2/1991
 JP 03-276487 B2 12/1991
 JP 03-286234 12/1991
 JP 05-298192 11/1993
 JP 07-141870 6/1995
 JP 08-77097 3/1996
 JP 11-149775 6/1999
 JP 22025255 A2 1/2002
 JP 3304893 B2 5/2002
 JP 04-327474 11/2004
 JP 2006236388 9/2006
 KR 1020040062717 7/2004
 KR 2005120344 12/2005
 WO WO95/05676 2/1995
 WO WO97/25674 7/1997
 WO WO9900734 1/1999
 WO WO00/45270 8/2000
 WO WO01/90900 11/2001
 WO WO01/97160 12/2001
 WO WO2004/044754 5/2004
 WO WO2004/051645 6/2004
 WO WO2006/072040 7/2006
 WO WO 2007002324 1/2007
 WO WO2007/028109 3/2007
 WO WO2007/038225 4/2007
 WO WO2007/095080 8/2007
 WO WO 2008063251 5/2008

OTHER PUBLICATIONS

Final Office Action from U.S. Appl. No. 11/461,435 mailed on Jan. 28, 2009.
 Non-final Office Action from U.S. Appl. No. 11/461,437 mailed on Jan. 26, 2009.
 Non-final Office Action from U.S. Appl. No. 11/939,432 mailed on Feb. 19, 2009.
 Office Action from U.S. Appl. No. 11/461,427 mailed on Sep. 5, 2008.
 Final Office Action from U.S. Appl. No. 11/461,430 mailed on Sep. 08, 2008.
 Notice of Allowance from U.S. Appl. No. 11/474,075 mailed on Nov. 26, 2008.
 Office Action from U.S. Appl. No. 11/474,076 mailed on Nov. 3, 2008.
 Office Action from U.S. Appl. No. 11/524,811 mailed on Sep. 17, 2008.
 German Office Action From German Patent Application No. 11 2006 002 300.4-55 Mailed Jun. 5, 2009 (With Translation).
 Non-Final Office Action From U.S. Appl. No. 11/461,430 Mailed Feb. 19, 2009.
 Final Office Action From U.S. Appl. No. 11/461,435 Mailed Jan. 28, 2009.
 Non-Final Office Action From U.S. Appl. No. 11/461,437 Mailed Jan. 26, 2009.
 Non-Final Office Action From U.S. Appl. No. 11/461,441 Mailed Apr. 2, 2009.
 Non-Final Office Action From U.S. Appl. No. 11/611,374 Mailed Mar. 23, 2009.
 Non-Final Office Action From U.S. Appl. No. 11/762,010 Mailed Mar. 20, 2009.
 Non-Final Office Action From U.S. Appl. No. 11/939,432 Mailed Feb. 6, 2009.
 Non-Final Office Action From U.S. Appl. No. 12/111,819 Mailed Apr. 27, 2009.
 Non-Final Office Action From U.S. Appl. No. 12/111,828 Mailed Apr. 17, 2009.
 Fang et al., W. Power Complexity Analysis of Adiabatic SRAM, 6th Int. Conference on ASIC, vol. 1, Oct. 2005, pp. 334-337.
 Pavan et al., P. A Complete Model of E2PROM Memory Cells for Circuit Simulations, IEEE Transactions on Computer-Aided Design of Integrated Circuits and Systems, vol. 22, No. 8, Aug. 2003, pp. 1072-1079.
 German Office Action From German Patent Application No. 11 2006 001 810.8-55 Mailed Apr. 20, 2009 (With Translation).

(56)

References Cited

OTHER PUBLICATIONS

Final Rejection From U.S. Appl. No. 11/461,437 Mailed Nov. 10, 2009.
 Final Rejection from U.S. Appl. No. 11/762,010 Mailed Dec. 4, 2009.
 Non-Final Rejection from U.S. Appl. No. 11/672,921 Mailed Dec. 8, 2009.
 Non-Final Rejection from U.S. Appl. No. 11/672,924 Mailed Dec. 14, 2009.
 Non-Final Rejection from U.S. Appl. No. 11/929,225 Mailed Dec. 14, 2009.
 Non-Final Rejection from U.S. Appl. No. 11/929,261 Mailed Dec. 14, 2009.
 Notice of Allowance From U.S. Appl. No. 11/611,374 Mailed Nov. 30, 2009.
 Notice of Allowance From U.S. Appl. No. 11/939,432 Mailed Dec. 1, 2009.
 Notice of Allowance From U.S. Appl. No. 12/111,819 Mailed Nov. 20, 2009.
 Notice of Allowance From U.S. Appl. No. 12/111,828 Mailed Dec. 15, 2009.
 Great Britain Office Action from GB Patent Application No. GB0800734.6 Mailed Mar. 1, 2010.
 Final Office Action from U.S. Appl. No. 11/461,420 Mailed Apr. 28, 2010.
 Notice of Allowance from U.S. Appl. No. 11/553,372 Mailed Mar. 12, 2010.
 Notice of Allowance from U.S. Appl. No. 11/553,399 Mailed Mar. 22, 2010.
 Non-Final Office Action from U.S. Appl. No. 11/588,739 Mailed Dec. 29, 2009.
 Notice of Allowance from U.S. Appl. No. 11/611,374 Mailed Apr. 5, 2010.
 Non-Final Office Action from U.S. Appl. No. 11/828,181 Mailed Mar. 2, 2010.
 Non-Final Office Action from U.S. Appl. No. 11/828,182 Mailed Mar. 29, 2010.
 Final Office Action from U.S. Appl. No. 11/858,518 Mailed Apr. 21, 2010.
 Non-Final Office Action from U.S. Appl. No. 11/929,432 Mailed Jan. 14, 2010.
 Non-Final Office Action from U.S. Appl. No. 11/929,571 Mailed Mar. 3, 2010.
 Non-Final Office Action from U.S. Appl. No. 11/929,636 Mailed Mar. 9, 2010.
 Non-Final Office Action from U.S. Appl. No. 11/929,655 Mailed Mar. 3, 2010.
 Non-Final Office Action from U.S. Appl. No. 11/939,432 Mailed Apr. 12, 2010.
 Notice of Allowance from U.S. Appl. No. 12/111,819 Mailed Mar. 10, 2010.
 Non-Final Office Action from U.S. Appl. No. 12/507,682 Mailed Mar. 8, 2010.
 Notice of Allowance from U.S. Appl. No. 11/762,010 Dated Jun. 8, 2011.
 Non-Final Office Action from U.S. Appl. No. 11/672,924 Dated Jun. 8, 2011.
 Non-Final Office Action from U.S. Appl. No. 11/929,225 Dated Jun. 8, 2011.
 Notice of Allowance from U.S. Appl. No. 11/929,500 Dated Jun. 13, 2011.
 Notice of Allowance from U.S. Appl. No. 11/941,589 Dated Jun. 15, 2011.
 Final Office Action from U.S. Appl. No. 12/057,306 Dated Jun. 15, 2011.
 Final Office Action from U.S. Appl. No. 12/769,428 Dated Jun. 16, 2011.
 Notice of Allowance from U.S. Appl. No. 12/203,100 Dated Jun. 17, 2011.
 Notice of Allowance from U.S. Appl. No. 11/762,013 Dated Jun. 20, 2011.

Non-Final Office Action from U.S. Appl. No. 12/797,557 Dated Jun. 21, 2011.
 Notice of Allowance from U.S. Appl. No. 11/929,483 Dated Jun. 23, 2011.
 Non-Final Office Action from U.S. Appl. No. 11/702,960 Dated Jun. 23, 2011.
 Non-Final Office Action from U.S. Appl. No. 11/929,655 Dated Jun. 24, 2011.
 Notice of Allowance from U.S. Appl. No. 11/763,365 Dated Jun. 24, 2011.
 Notice of Allowance from U.S. Appl. No. 11/611,374 Dated Jun. 24, 2011.
 Notice of Allowance from U.S. Appl. No. 12/838,896 Dated Apr. 19, 2011.
 Notice of Allowance from U.S. Appl. No. 11/702,981 Dated Apr. 25, 2011.
 Notice of Allowance from U.S. Appl. No. 11/929,320 Dated May 5, 2011.
 Final Office Action from U.S. Appl. No. 11/939,440 Dated May 19, 2011.
 Final Office Action from Application No. 11/855,805, Dated May 26, 2011.
 Non-Final Office Action from U.S. Appl. No. 11/672,921 Dated May 27, 2011.
 Supplemental European Search Report and Search Opinion issued Sep. 21, 2009 in European Application No. 07870726.2, 8 pp.
 Wu et al., 'eNVy: A Non-Volatile, Main Memory Storage System', ASPLOS-VI Proceedings, Oct. 4-7, 1994, pp. 86-97.
 Buffer Device for Memory Modules (DIMM)', IP.com Prior Art Database, <URL: <http://ip.com/IPCOM/000144850>>, Feb. 10, 2007, 1 pg.
 German Office Action from German Patent Application No. 11 2006 002 300.4-55 Dated May 11, 2009 (With Translation).
 Great Britain Office Action from GB Patent Application No. GB0803913.3 Dated Mar. 1, 2010.
 Preliminary Report on Patentability From PCT Application No. PCT/US06/24360 Dated on Jan. 10, 2008.
 Written Opinion From PCT Application No. PCT/US06/24360 Dated on Jan. 8, 2007.
 International Search Report From PCT Application No. PCT/US06/34390 Dated on Nov. 21, 2007.
 Written Opinion From PCT Application No. PCT/US06/34390 Dated on Nov. 21, 2007.
 International Preliminary Examination Report From PCT Application No. PCT/US07/016385 Dated Feb. 3, 2009.
 Search Report and Written Opinion From PCT Application No. PCT/US07/03460 Dated on Feb. 14, 2008.
 Search Report From PCT Application No. PCT/US10/038041 Dated Aug. 23, 2010.
 Non-Final Office Action from Application No. 11/461,420 Dated Jul. 23, 2009.
 Notice of Allowance from Application No. 11/461,430 Dated Sep. 10, 2009.
 Non-Final Office Action from Application No. 11/461,435 Dated Aug. 5, 2009.
 Final Office Action from Application No. 11/461,435 Dated May 13, 2010.
 Non-Final Office Action from Application No. 11/461,437 Dated Jan. 4, 2011.
 Non-Final Office Action from Application No. 11/515,167 Dated Sep. 25, 2009.
 Final Office Action from Application No. 11/515,167 Dated Jun. 3, 2010.
 Non-Final Office Action from Application No. 11/515,223 Dated Sep. 22, 2009.
 Notice of Allowance from Application No. 11/515,223 Dated Jul. 30, 2010.
 Notice of Allowance from Application No. 11/515,223 Dated Feb. 4, 2011.
 Non-Final Office Action from Application No. 11/538,041 Dated Jun. 10, 2009.
 Non-Final Office Action from Application No. 11/553,372 Dated Jun. 25, 2009.

(56)

References Cited

OTHER PUBLICATIONS

Notice of Allowance from Application No. 11/553,372 Dated Sep. 30, 2009.
 Notice of Allowance from Application No. 11/553,372 Dated Aug. 4, 2010.
 Non-Final Office Action from Application No. 11/553,372 Dated Jan. 5, 2011.
 Non-Final Office Action from Application No. 11/553,390 Dated Sep. 9, 2009.
 Final Office Action from Application No. 11/553,390 Dated Jun. 24, 2010.
 Non-Final Office Action from Application No. 11/553,399 Dated Jul. 7, 2009.
 Notice of Allowance from Application No. 11/553,399 Dated Oct. 13, 2009.
 Notice of Allowance from Application No. 11/553,399 Dated Dec. 3, 2010.
 Final Office Action from Application No. 11/588,739 Dated Dec. 15, 2010.
 Notice of Allowance from Application No. 11/611,374 Dated Sep. 15, 2009.
 Notice of Allowance from Application No. 11/611,374 Dated Jul. 19, 2010.
 Notice of Allowance from Application No. 11/611,374 Dated Oct. 29, 2010.
 Final Office Action from Application No. 11/672,921 Dated Jul. 23, 2010.
 Final Office Action from Application No. 11/672,924 Dated Sep. 7, 2010.
 Non-Final Office Action from Application No. 11/702,960 Dated Sep. 25, 2009.
 Final Office Action from Application No. 11/702,960 Dated Jun. 21, 2010.
 Non-Final Office Action from Application No. 11/702,981 Dated Mar. 11, 2009.
 Non-Final Office Action from Application No. 11/702,981 Dated Aug. 19, 2009.
 Notice of Allowance from Application No. 11/762,010 Dated Jul. 2, 2010.
 Notice of Allowance from Application No. 11/762,010 Dated Oct. 22, 2010.
 Notice of Allowance from Application No. 11/762,010 Dated Feb. 18, 2011.
 Non-Final Office Action from Application No. 11/762,013 Dated Jun. 5, 2009.
 Notice of Allowance from Application No. 11/762,013 Dated Aug. 17, 2010.
 Notice of Allowance from Application No. 11/762,013 Dated Dec. 7, 2010.
 Non-Final Office Action from Application No. 11/763,365 Dated Oct. 28, 2009.
 Notice of Allowance from Application No. 11/763,365 Dated Jun. 29, 2010.
 Notice of Allowance from Application No. 11/763,365 Dated Oct. 20, 2010.
 Non-Final Office Action from Application No. 11/828,181 Dated Mar. 2, 2010.
 Final Office Action from Application No. 11/828,182 Dated Dec. 22, 2010.
 Non-Final Office Action from Application No. 11/855,805 Dated Sep. 21, 2010.
 Non-Final Office Action from Application No. 11/855,826 Dated Jan. 13, 2011.
 Non-Final Office Action from Application No. 11/858,518 Dated Aug. 14, 2009.
 Non-Final Office Action from Application No. 11/858,518 Dated Sep. 8, 2010.
 Final Office Action from Application No. 11/929,225 Dated Aug. 27, 2010.

Final Office Action from Application No. 11/929,261 Dated Sep. 7, 2010.
 Final Office Action from Application No. 11/929,286 Dated Aug. 20, 2010.
 Notice of Allowance from Application No. 11/929,320 Dated Sep. 29, 2010.
 Final Office Action from Application No. 11/929,403 Dated Aug. 31, 2010.
 Final Office Action from Application No. 11/929,417 Dated Aug. 31, 2010.
 Final Office Action from Application No. 11/929,432 Dated Aug. 20, 2010.
 Final Office Action from Application No. 11/929,450 Dated Aug. 20, 2010.
 Notice of Allowance from Application No. 11/929,483 Dated Oct. 7, 2010.
 Non-Final Office Action from Application No. 11/929,500 Dated Oct. 13, 2009.
 Final Office Action from Application No. 11/929,500 Dated Jun. 24, 2010.
 Final Office Action from Application No. 11/929,655 Dated Nov. 22, 2010.
 Notice of Allowance from Application No. 11/939,432 Dated Sep. 24, 2009.
 Notice of Allowance from Application No. 11/939,432 Dated Feb. 18, 2011.
 Non-Final Office Action from Application No. 11/939,440 Dated Sep. 17, 2010.
 Non-Final Office Action from Application No. 11/941,589 Dated Oct. 1, 2009.
 Notice of Allowance from Application No. 11/941,589 Dated Oct. 25, 2010.
 Non-Final Office Action from Application No. 12/057,306 Dated Oct. 8, 2010.
 Notice of Allowance from Application No. 12/144,396 Dated Feb. 1, 2011.
 Non-Final Office Action from Application No. 12/203,100 Dated Dec. 1, 2010.
 Non-Final Office Action from Application No. 12/574,628 Dated Jun. 10, 2010.
 Non-Final Office Action from Application No. 12/769,428 Dated Nov. 8, 2010.
 Non-Final Office Action from Application No. 12/816,756 Dated Feb. 7, 2011.
 Non-Final Office Action from Application No. 12/838,896 Dated Sep. 3, 2010.
 Notice of Allowance from Application No. 11/762,013 Dated Feb. 22, 2011.
 Notice of Allowance from Application No. 11/929,500 Dated Feb. 24, 2011.
 Notice of Allowance from Application No. 11/763,365 Dated Mar. 1, 2011.
 Final Office Action from Application No. 12/574,628 Dated Mar. 3, 2011.
 Final Office Action from Application No. 11/929,571 Dated Mar. 3, 2011.
 Notice of Allowance from Application No. 11/611,374 Dated Mar. 4, 2011.
 Notice of Allowance from Application No. 11/929,483 Dated Mar. 4, 2011.
 Notice of Allowance from Application No. 11/553,399 Dated Mar. 18, 2011.
 Final Office Action from Application No. 12/507,682 Dated Mar. 29, 2011.
 Non-Final Office Action from Application No. 11/929,403 Dated Mar. 31, 2011.
 Non-Final Office Action from Application No. 11/929,417 Dated Mar. 31, 2011.
 Office Action, including English translation, from co-pending Japanese application No. 2008-529353, Dated Jul. 31, 2012.
 Final Office Action from U.S. Appl. No. 13/315,933, Dated Aug. 24, 2012.

(56)

References Cited

OTHER PUBLICATIONS

Final Office Action from U.S. Appl. No. 13/276,212, Dated Aug. 30, 2012.
 Non-Final Office Action from U.S. Appl. No. 13/367,182, Dated Aug. 31, 2012.
 Notice of Allowance from U.S. Appl. No. 11/461,420, Dated Sep. 5, 2012.
 Final Office Action from U.S. Appl. No. 13/280,251, Dated Sep. 12, 2012.
 Non-Final Office Action from U.S. Appl. No. 11/929,225, Dated Sep. 17, 2012.
 Notice of Allowance from U.S. Appl. No. 12/508,496, Dated Sep. 17, 2012.
 Non-Final Office Action from U.S. Appl. No. 11/672,921, Dated Oct. 1, 2012.
 Notice of Allowance from U.S. Appl. No. 12/057,306, Dated Oct. 10, 2012.
 Notice Allowance from U.S. Appl. No. 12/144,396, Dated Oct. 11, 2012.
 Non-Final Office Action from U.S. Appl. No. 13/411,489, Dated Oct. 17, 2012.
 Non-Final Office Action from U.S. Appl. No. 13/471,283, Dated Dec. 7, 2012.
 English translation of Office Action from co-pending Korean patent application No. KR1020087005172, dated Dec. 20, 2012.
 Office Action, including English translation, from co-pending Japanese application No. 2008-529353, Dated Dec. 27, 2012.
 Office Action from co-pending European patent application No. EP12150798, Dated Jan. 3, 2013.
 Final Office Action from U.S. Appl. No. 11/672,924, Dated Feb. 1, 2013.
 Non-Final Office Action from U.S. Appl. No. 13/260,650, Dated Feb. 1, 2013.
 Notice of Allowance from U.S. Appl. No. 13/141,844, Dated Feb. 5, 2013.
 Non-Final Office Action from U.S. Appl. No. 11/828,182 Dated Jun. 27, 2011.
 Non-Final Office Action from U.S. Appl. No. 11/828,181 Dated Jun. 27, 2011.
 Non-Final Office Action from U.S. Appl. No. 12/378,328 Dated Jul. 15, 2011.
 Final Office Action from U.S. Appl. No. 11/461,420 Dated Jul. 20, 2011.
 Notice of Allowance from U.S. Appl. No. 11/461,437 Dated Jul. 25, 2011.
 Notice of Allowance from U.S. Appl. No. 11/702,981 Dated Aug. 5, 2011.
 Notice of Allowability from U.S. Appl. No. 11/855,826 Dated Aug. 15, 2011.
 Non-Final Office Action from U.S. Appl. No. 12/574,628 Dated Sep. 20, 2011.
 Non-Final Office Action from U.S. Appl. No. 11/858,518 Dated Sep. 27, 2011.
 Notice of Allowance from U.S. Appl. No. 11/929,571 Dated Sep. 27, 2011.
 Notice of Allowance from U.S. Appl. No. 11/929,500 Dated Sep. 27, 2011.
 Notice of Allowance from U.S. Appl. No. 11/941,589 Dated Sep. 30, 2011.
 Notice of Allowance from U.S. Appl. No. 12/816,756 Dated Oct. 3, 2011.
 Non-Final Office Action from U.S. Appl. No. 12/508,496 Dated Oct. 11, 2011.
 Non-Final Office Action from U.S. Appl. No. 11/588,739 Dated Oct. 13, 2011.
 Notice of Allowance from U.S. Appl. No. 11/939,432 Dated Oct. 24, 2011.
 Non-Final Office Action from U.S. Appl. No. 11/929,631 Dated Nov. 1, 2011.

Non-Final Office Action from U.S. Appl. No. 11/553,372 Dated Nov. 14, 2011.
 Notice of Allowance from U.S. Appl. No. 11/515,223 Dated Nov. 29, 2011.
 Notice of Allowance from U.S. Appl. No. 12/769,428 Dated Nov. 28, 2011.
 Final Office Action from U.S. Appl. No. 11/939,440 Dated Dec. 12, 2011.
 Notice of Allowance from U.S. Appl. No. 12/797,557 Dated Dec. 28, 2011.
 Office Action, including English translation, from co-pending Japanese application No. 2008-529353, Dated Jan. 10, 2012.
 Notice of Allowance from U.S. Appl. No. 12/838,896 Dated Jan. 18, 2012.
 Final Office Action from U.S. Appl. No. 11/929,655 Dated Jan. 19, 2012.
 Final Office Action from U.S. Appl. No. 12/378,328 Dated Feb. 3, 2012.
 Final Office Action from U.S. Appl. No. 11/672,921 Dated Feb. 16, 2012.
 Final Office Action from U.S. Appl. No. 11/672,924 Dated Feb. 16, 2012.
 Final Office Action from U.S. Appl. No. 11/929,225 Dated Feb. 16, 2012.
 International Search Report for Application No. EP12150807 Dated Feb. 16, 2012.
 Final Office Action from U.S. Appl. No. 11/828,181 Dated Feb. 23, 2012.
 Non-Final Office Action from U.S. Appl. No. 11/461,520 Dated Feb. 29, 2012.
 Notice of Allowance from U.S. Appl. No. 12/574,628 Dated Mar. 6, 2012.
 Non-Final Office Action from U.S. Appl. No. 13/276,212 Dated Mar. 15, 2012.
 Non-Final Office Action from U.S. Appl. No. 13/343,612 Dated Mar. 29, 2012.
 Notice of Allowance from U.S. Appl. No. 11/939,440 Dated Mar. 30, 2012.
 European Search Report from co-pending European application No. 11194876.6-2212/2450798, Dated Apr. 12, 2012.
 European Search Report from co-pending European application No. 11194862.6-2212/2450800, Dated Apr. 12, 2012.
 Notice of Allowance from U.S. Appl. No. 11/929,636, Dated Apr. 17, 2012.
 Final Office Action from U.S. Appl. No. 11/858,518, Dated Apr. 17, 2012.
 European Search Report from co-pending European application No. 11194883.2-2212, Dated Apr. 27, 2012.
 Non-Final Office Action from U.S. Appl. No. 11/553/372, Dated May 3, 2012.
 Notice of Allowance from U.S. Appl. No. 11/929,631, Dated May 3, 2012.
 Non-Final Office Action from U.S. Appl. No. 13/165,713, Dated May 22, 2012.
 Non-Final Office Action from U.S. Appl. No. 12/144,396, Dated May 29, 2012.
 Non-Final Office Action from U.S. Appl. No. 13/165,713, Dated May 31, 2012.
 Non-Final Office Action from U.S. Appl. No. 13/280,251, Dated Jun. 12, 2012.
 Final Office Action from U.S. Appl. No. 11/855,805, Dated Jun. 14, 2012.
 Notice of Allowance from U.S. Appl. No. 13/473,827, Dated Feb. 15, 2013.
 Notice of Allowance from U.S. Appl. No. 12/378,328, Dated Feb. 27, 2013.
 Non-Final Office Action from U.S. Appl. No. 13/536,093, Dated Mar. 1, 2013.
 Office Action from co-pending Japanese patent application No. 2012-132119, Dated Mar. 6, 2013.
 Notice of Allowance from U.S. Appl. No. 11/461,435, Dated Mar. 6, 2013.

(56)

References Cited

OTHER PUBLICATIONS

Notice of Allowance from U.S. Appl. No. 11/515,223, Dated Mar. 18, 2013.

Notice of Allowance from U.S. Appl. No. 13/471,283, Dated Mar. 21, 2013.

Extended European Search Report for co-pending European patent application No. EP12150807.1, dated Feb. 1, 2013, mailed Mar. 22, 2013.

Notice of Allowance from U.S. Appl. No. 13/181,716, Dated Apr. 3, 2013.

English translation of Office Action from co-pending Korean patent application No. KR1020087019582, Dated Mar. 13, 2013.

Notice of Allowance from U.S. Appl. No. 13/618,246, Dated Apr. 23, 2013.

Notice of Allowance from U.S. Appl. No. 13/182,234, Dated May 1, 2013.

Final Office Action from U.S. Appl. No. 13/315,933, Dated May 3, 2013.

English Translation of Office Action from co-pending Korean patent application No. 10-2013-7004006, Dated Apr. 12, 2013.

Non-Final Office Action from U.S. Appl. No. 13/620,793, Dated May 6, 2013.

Non-Final Office Action from U.S. Appl. No. 13/620,565, Dated May 24, 2013.

Final Office Action from U.S. Appl. No. 11/929,225, Dated May 24, 2013.

Final Office Action from U.S. Appl. No. 11/672,921, Dated May 24, 2013.

Notice of Allowance from U.S. Appl. No. 11/929,631, Dated May 28, 2013.

Notice of Allowance from U.S. Appl. No. 13/620,424, Dated May 29, 2013.

Notice of Allowance from U.S. Appl. No. 13/341,844, Dated May 30, 2013.

Non-Final Office Action from U.S. Appl. No. 13/455,691, Dated Jun. 4, 2013.

Non-Final Office Action from U.S. Appl. No. 13/620,199, Dated Jun. 17, 2013.

Non-Final Office Action from U.S. Appl. No. 13/620,207, Dated Jun. 20, 2013.

Non-Final Office Action from U.S. Appl. No. 11/828,182, Dated Jun. 20, 2013.

Final Office Action from U.S. Appl. No. 11/828,181, Dated Jun. 20, 2013.

Notice of Allowance from U.S. Appl. No. 13/597,895, Dated Jun. 25, 2013.

Non-Final Office Action from U.S. Appl. No. 13/620,645, Dated Jun. 26, 2013.

Notice of Allowance from U.S. Appl. No. 13/471,283, Dated Jun. 28, 2013.

Notice of Allowance from U.S. Appl. No. 13/181,747, Dated Jul. 9, 2013.

Notice of Allowance from U.S. Appl. No. 11/515,223, Dated Jul. 18, 2013.

Notice of Allowance from U.S. Appl. No. 13/182,234, Dated Jul. 22, 2013.

Notice of Allowance from U.S. Appl. No. 13/181,716, Dated Jul. 22, 2013.

Non-Final Office Action from U.S. Appl. No. 13/620,233, Dated Aug. 2, 2013.

Final Office Action from U.S. Appl. No. 13/367,182, Dated Aug. 8, 2013.

Notice of Allowance from U.S. Appl. No. 13/615,008, Dated Aug. 15, 2013.

Notice of Allowance from U.S. Appl. No. 13/620,425, Dated Aug. 20, 2013.

Non-Final Office Action from U.S. Appl. No. 13/620,601, Dated Aug. 23, 2013.

* cited by examiner

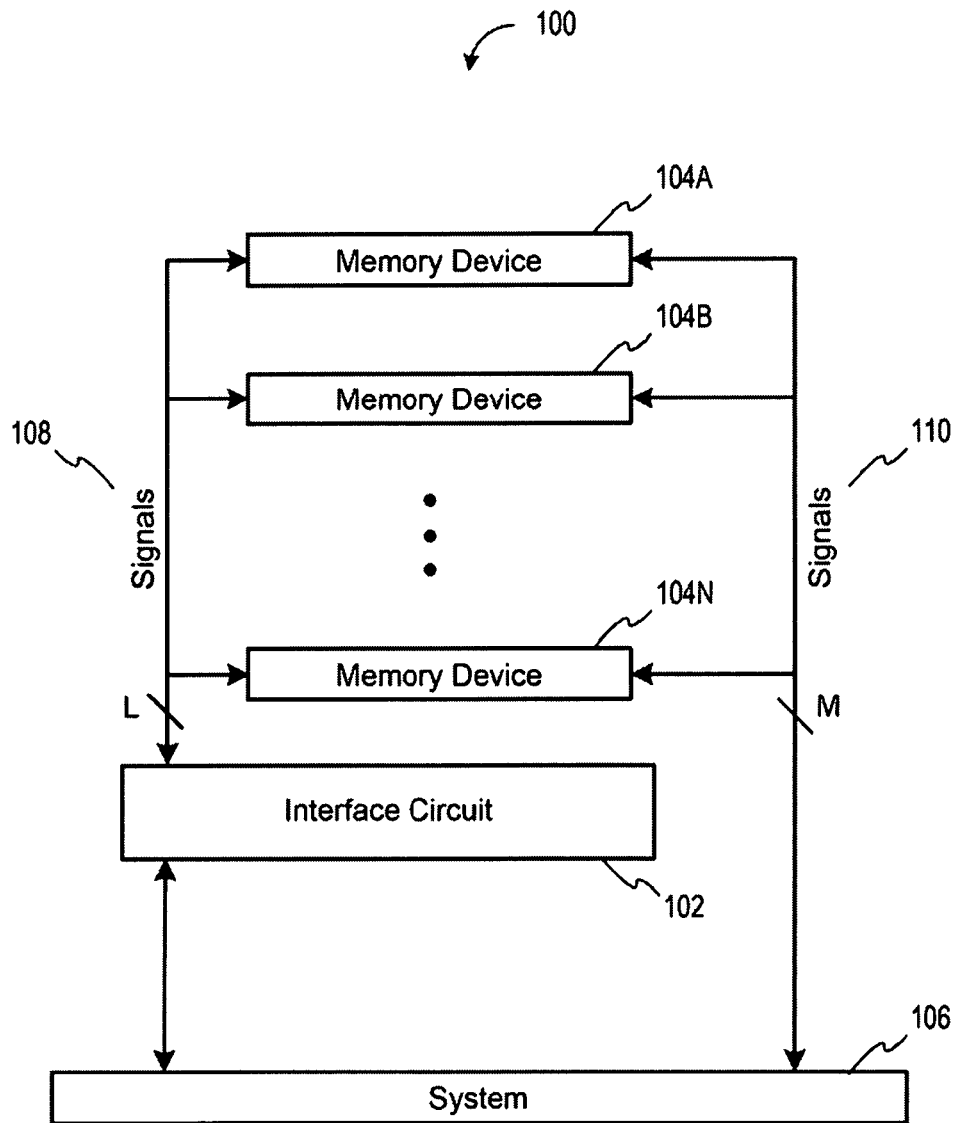

FIG. 1A

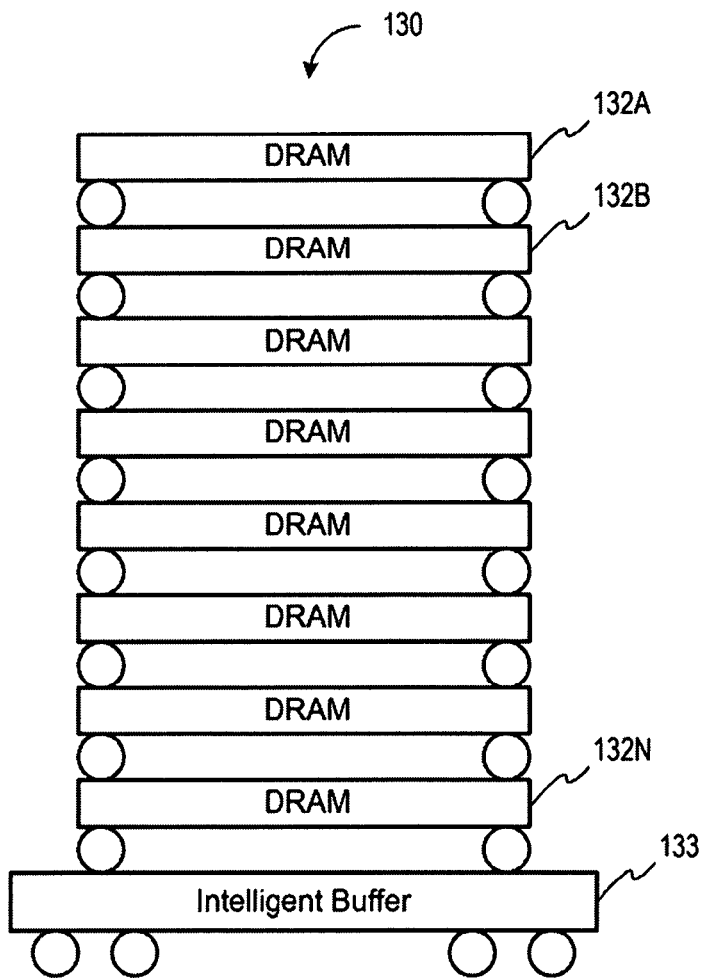

FIG. 1B

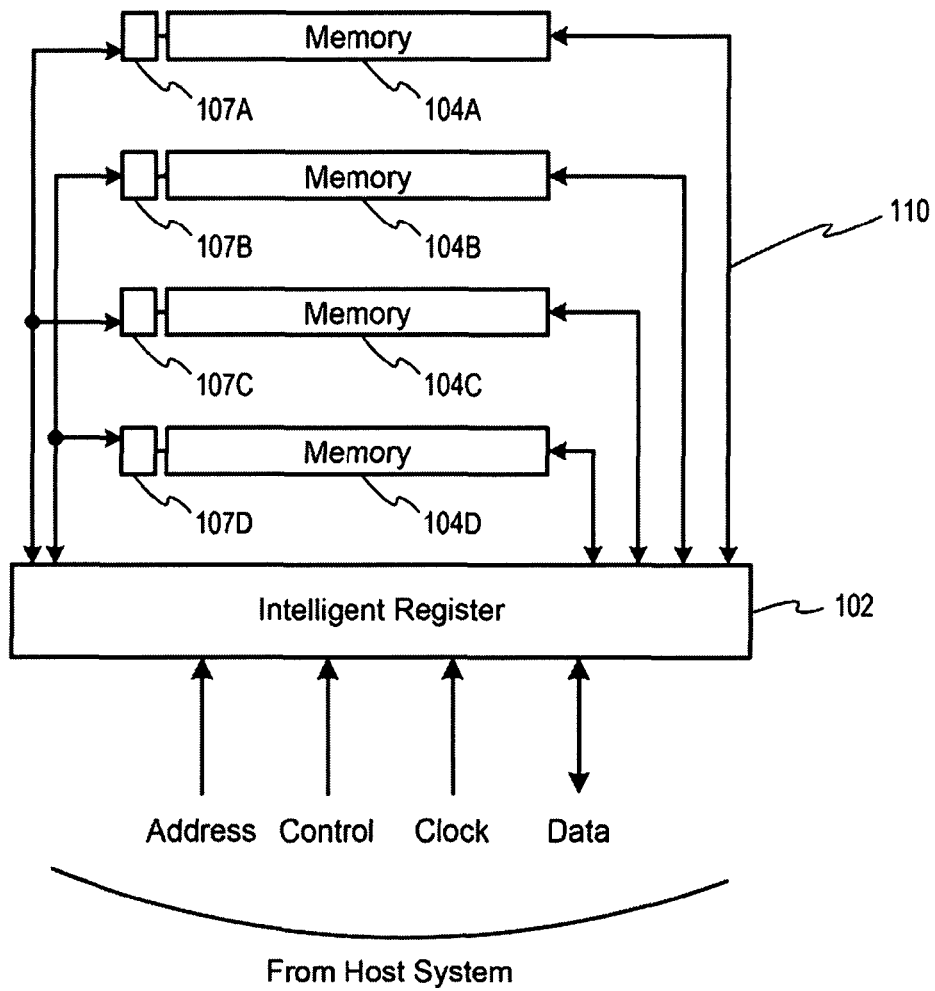

FIG. 1C

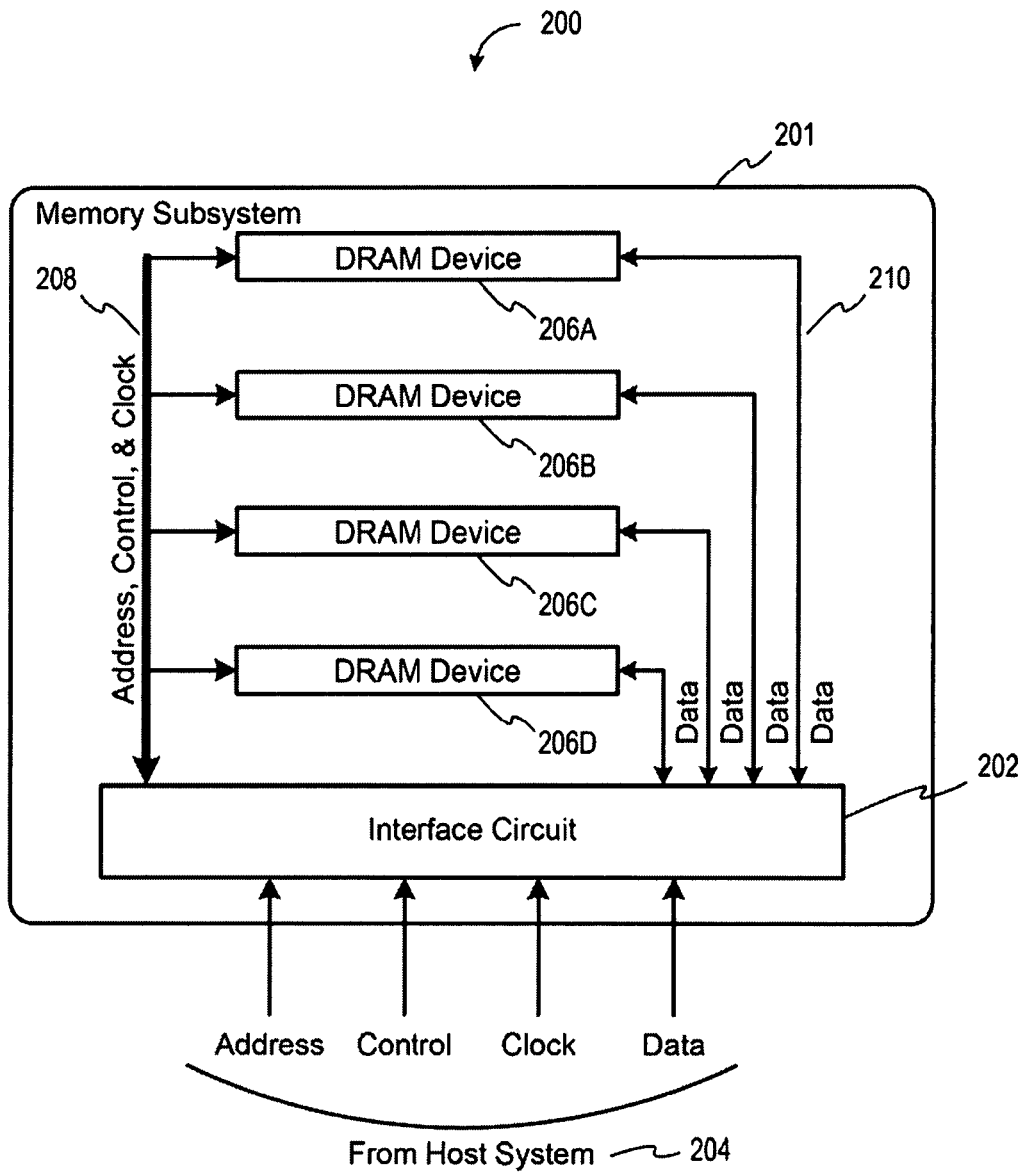

FIG. 2

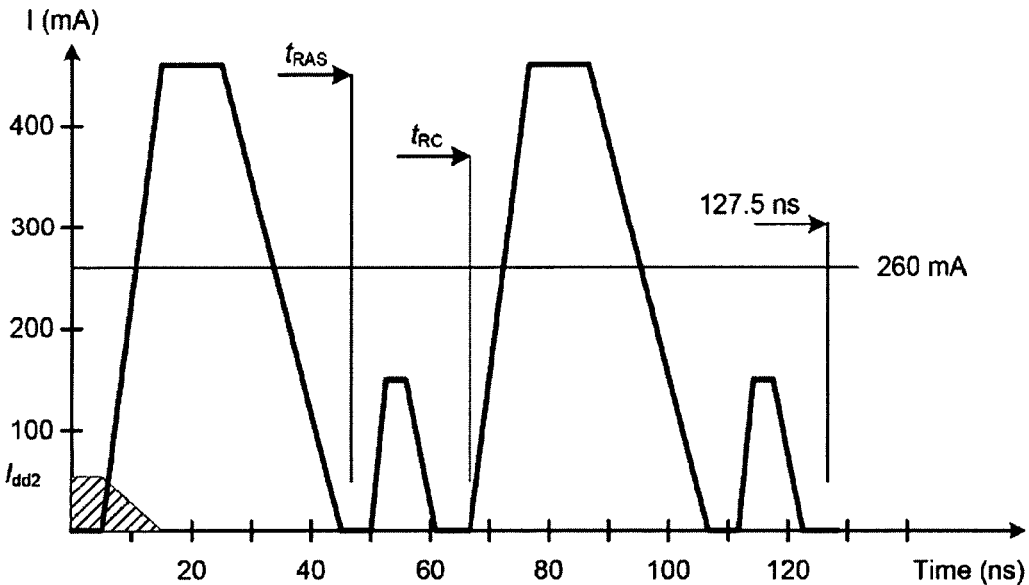

FIG. 3

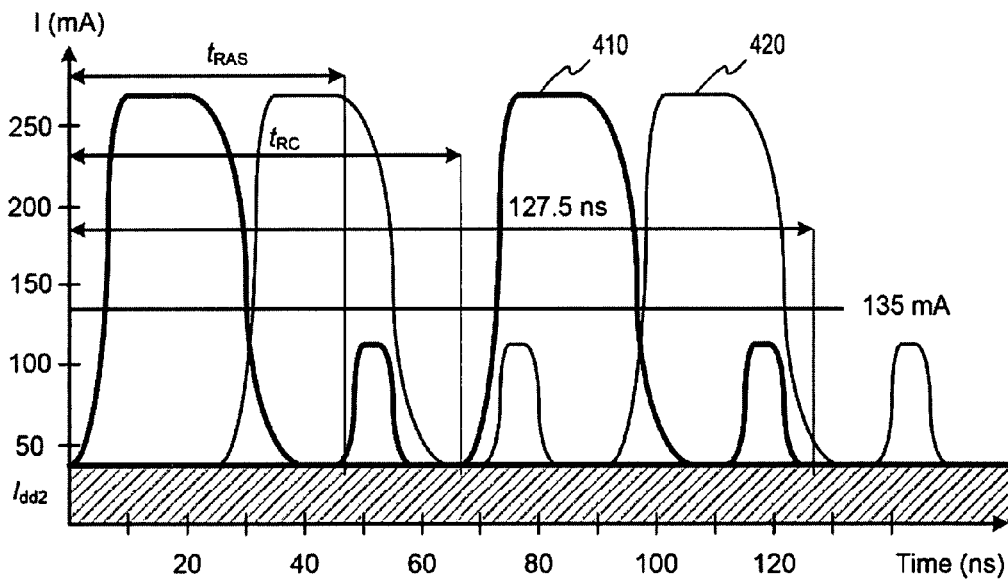

FIG. 4A

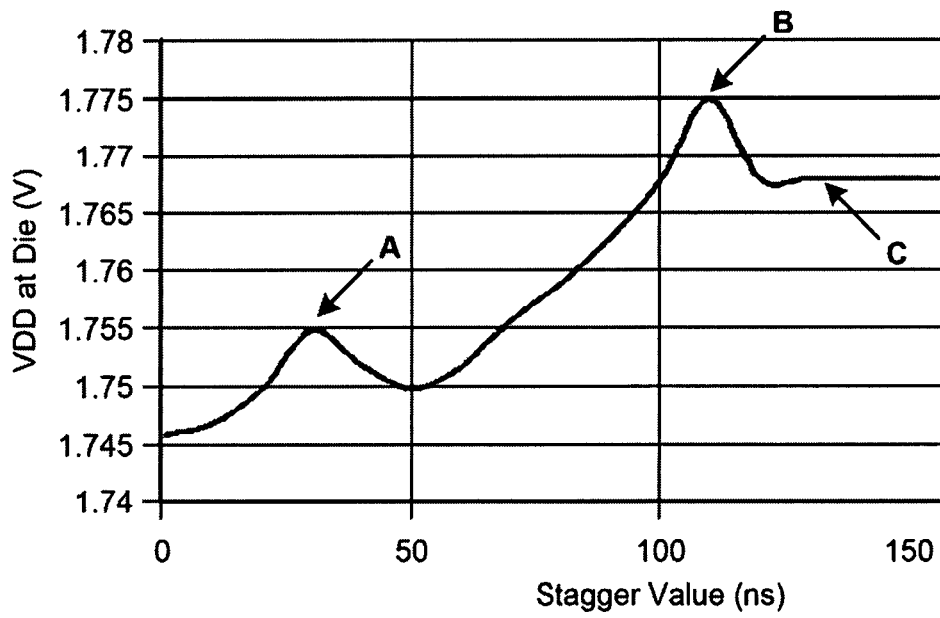

FIG. 4b

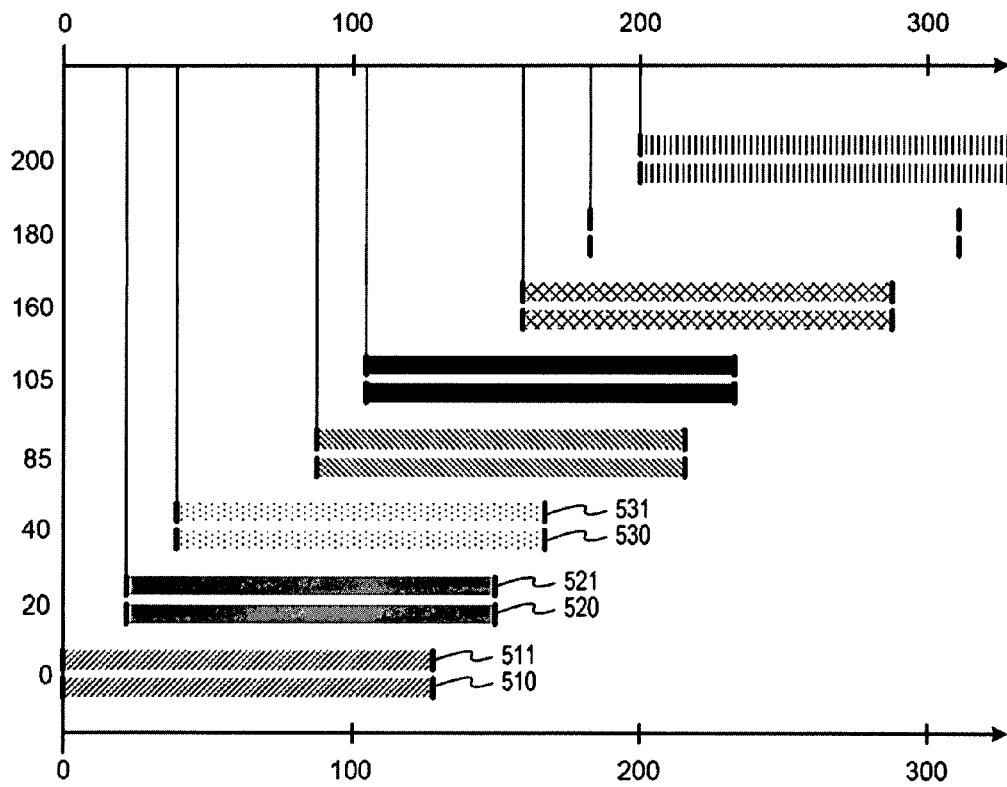

FIG. 5

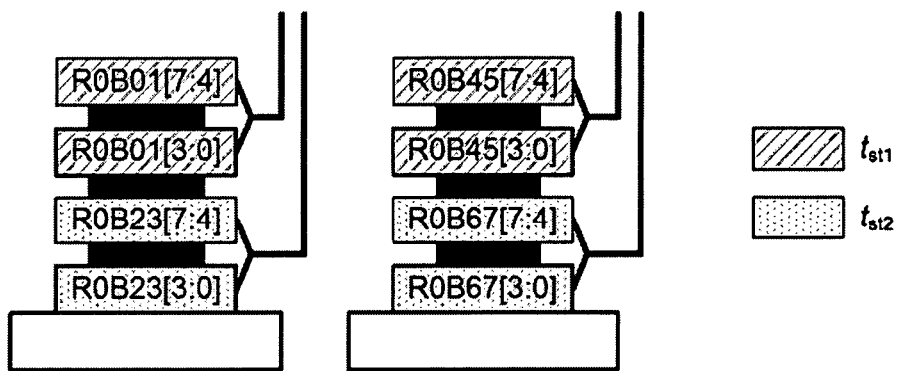

FIG. 6

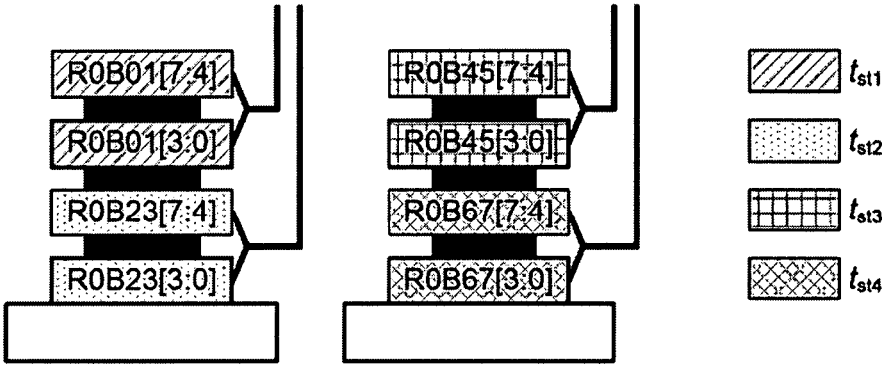

FIG. 7

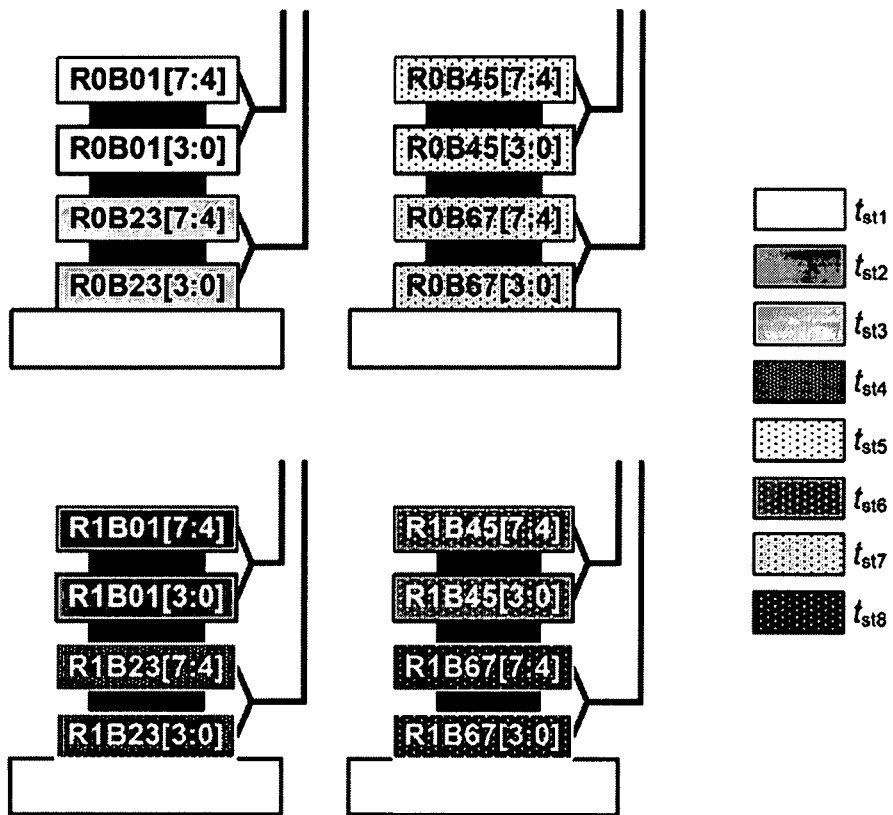

FIG. 8

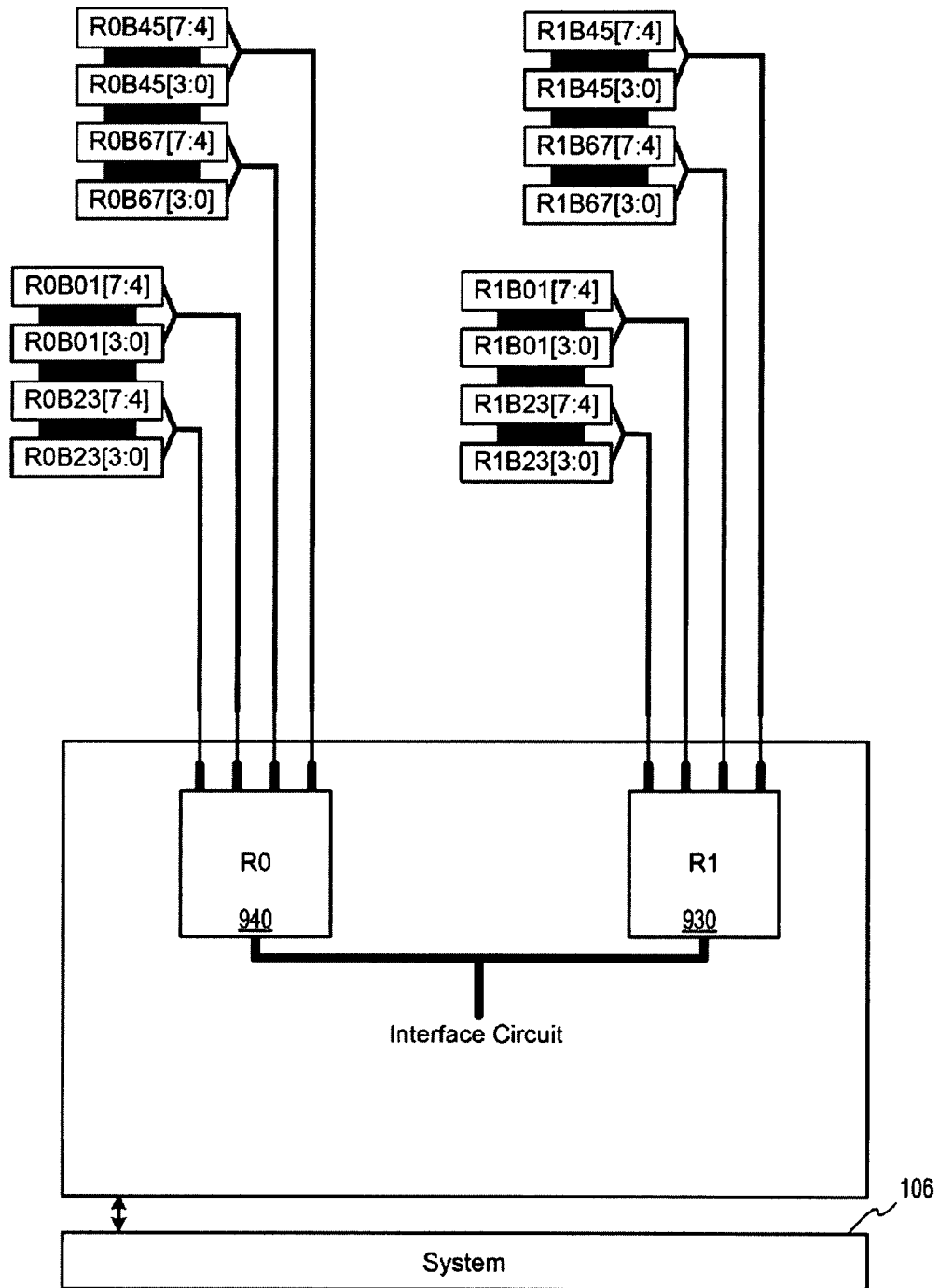

FIG. 9

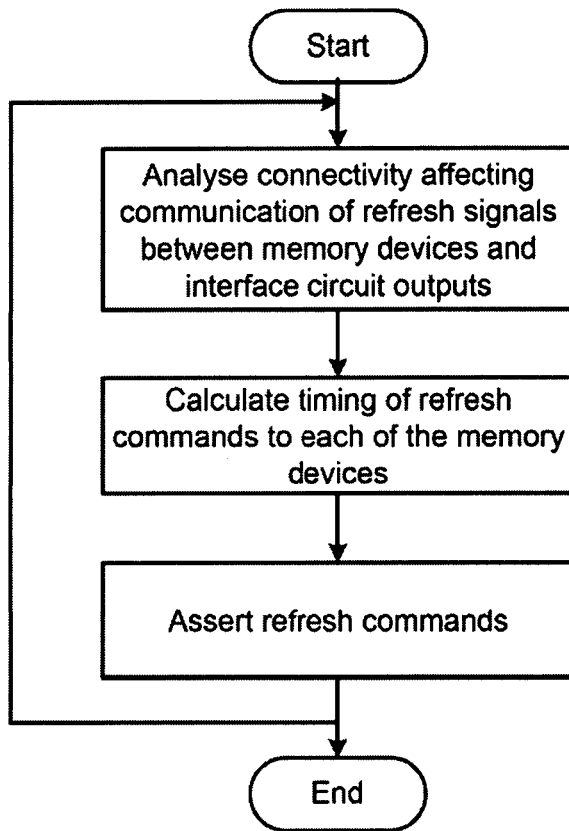

FIG. 10A

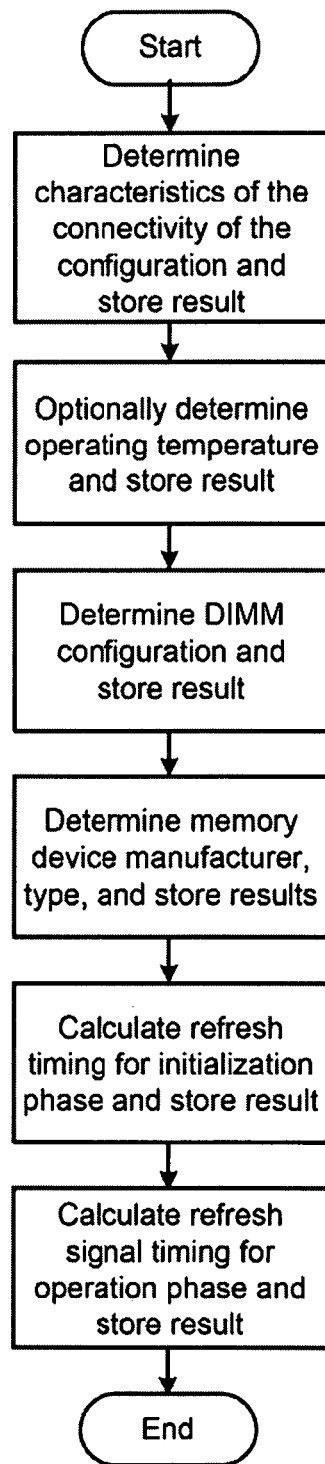

FIG. 10B

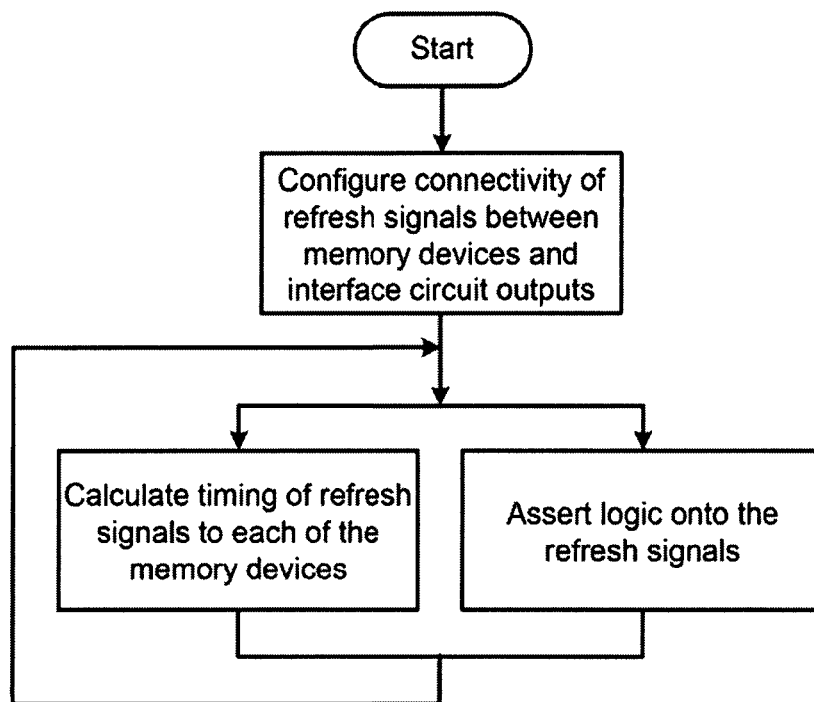

FIG. 11

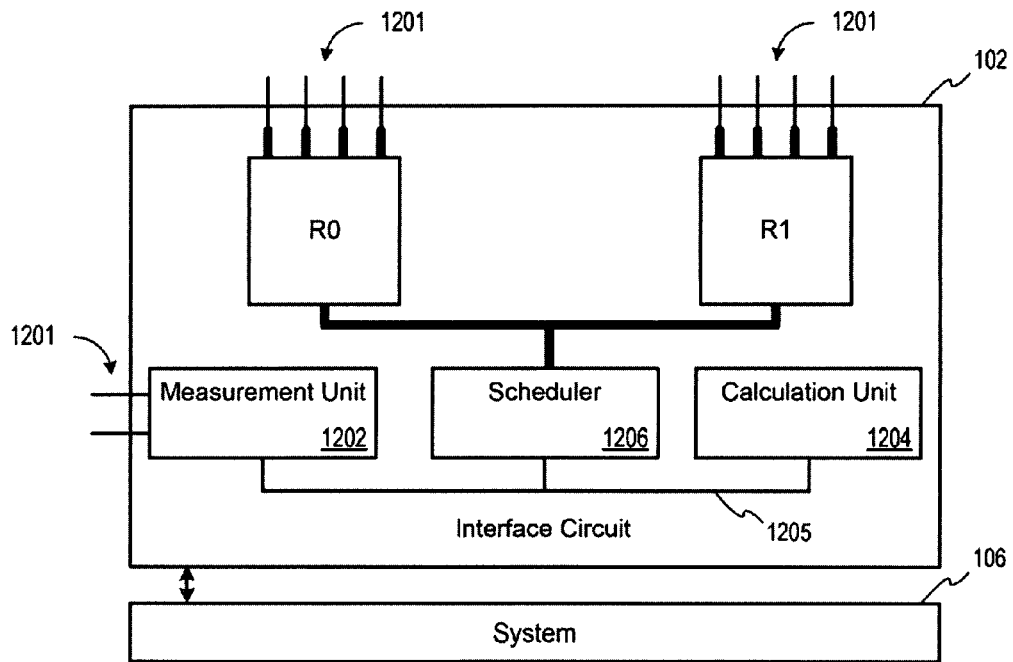

FIG. 12

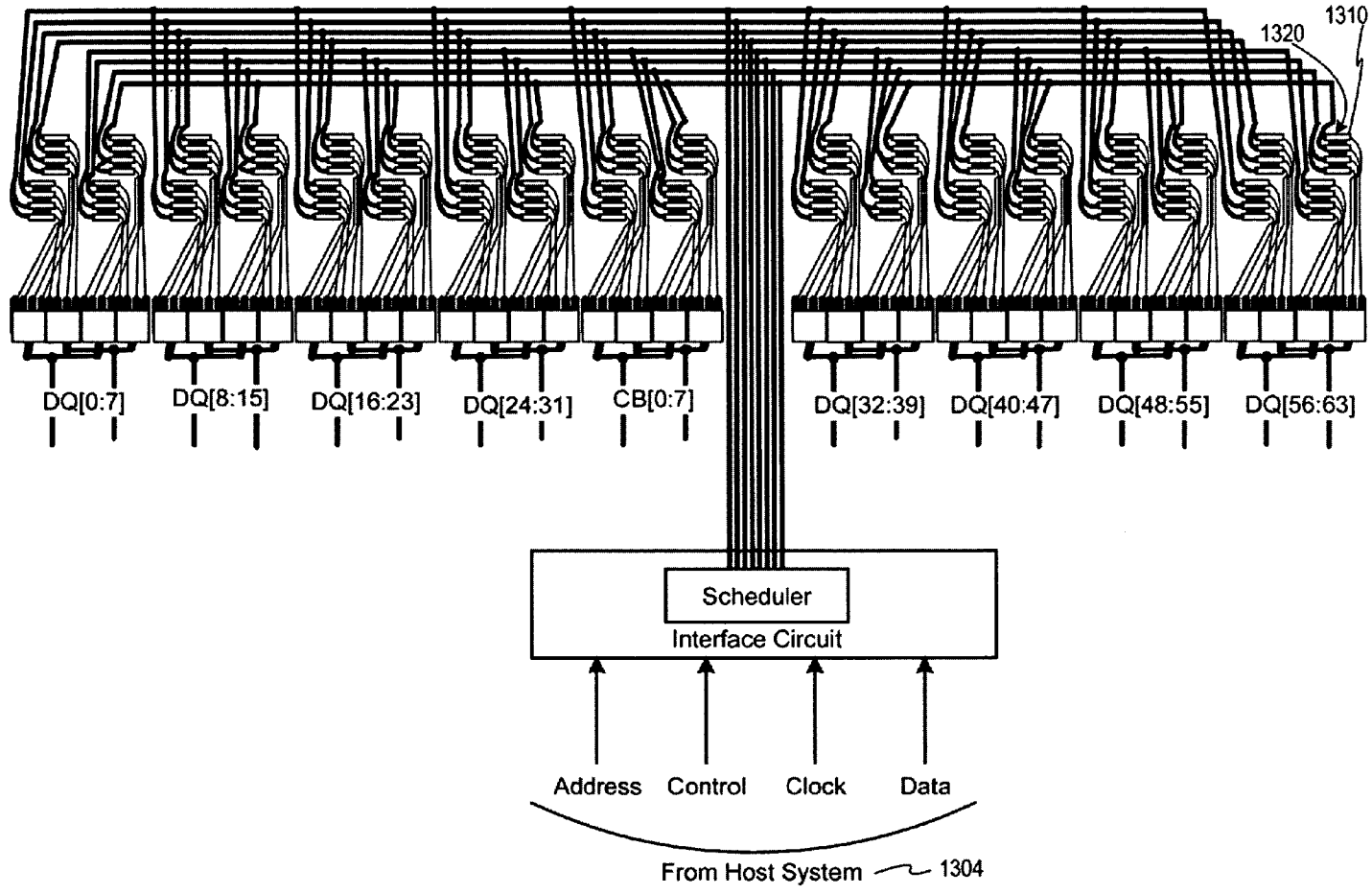

FIG. 13

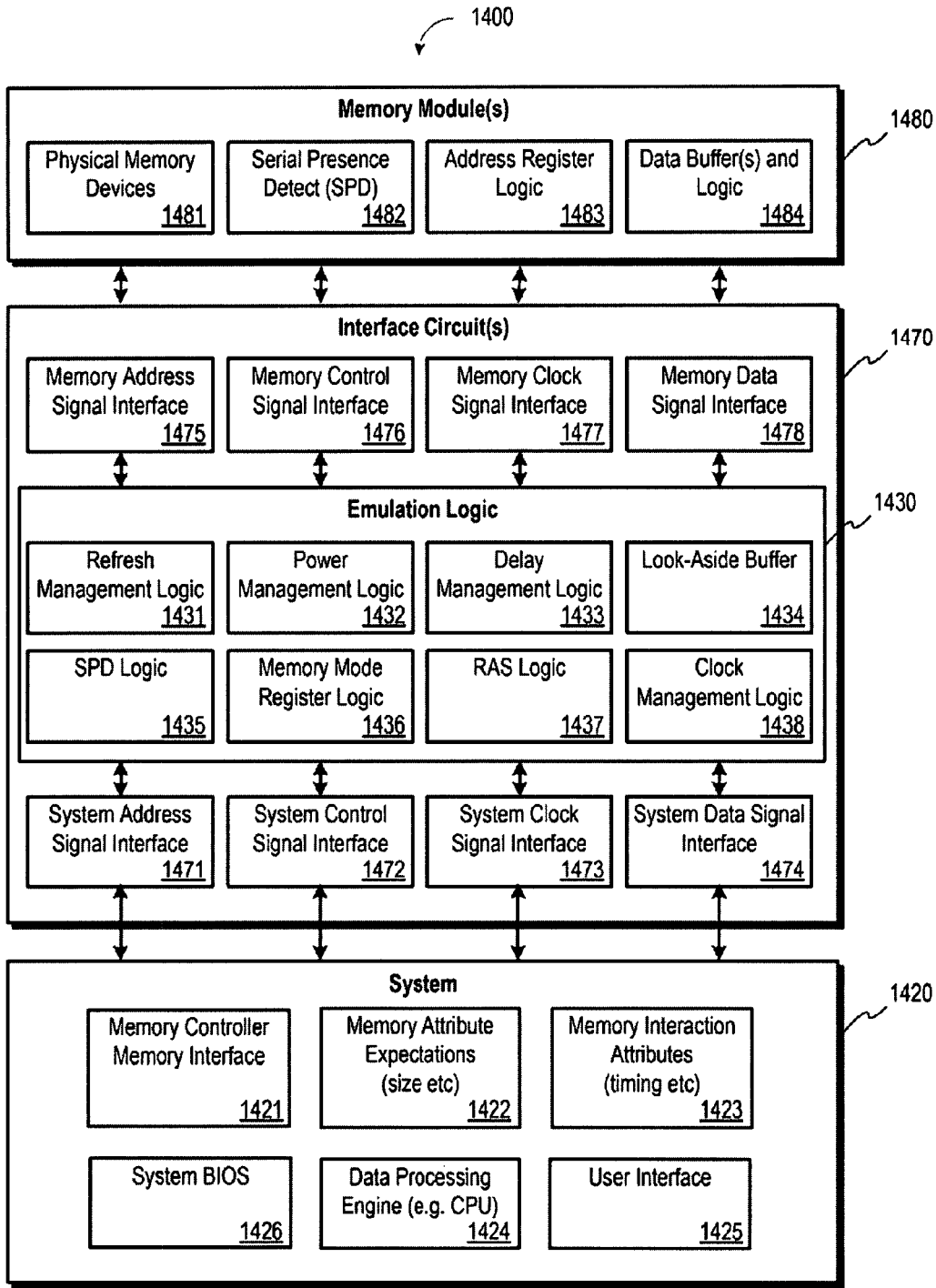

FIG. 14

REFRESH MANAGEMENT OF MEMORY MODULES

CROSS-REFERENCE TO RELATED APPLICATIONS

This application is a continuation of the U.S. patent application Ser. No. 11/828,181, filed on Jul. 25, 2007, which is a continuation-in-part of the U.S. patent application Ser. No. 11/584,179, filed on Oct. 20, 2006 now U.S. Pat. No. 7,581,127, which is a continuation of the U.S. patent application Ser. No. 11/524,811, filed on Sep. 20, 2006 now U.S. Pat. No. 7,590,796, which is a continuation-in-part of the U.S. patent application Ser. No. 11/461,439, filed on Jul. 31, 2006 now U.S. Pat. No. 7,580,312. Application Ser. No. 11/828,181 also claims the priority benefit of U.S. Provisional Patent Application No. 60/823,229, filed on Aug. 22, 2006. The subject matter the above related applications is hereby incorporated herein by reference. However, insofar as any definitions, information used for claim interpretation, etc. from the above parent application conflict with that set forth herein, such definitions, information, etc. in the present application should apply.

BACKGROUND OF THE INVENTION

1. Field of the Invention

Embodiments of the present invention generally relate to memory modules and, more specifically, to methods and apparatus for refresh management of memory modules.

2. Description of the Related Art

The storage capacity of memory systems is increasing rapidly due to various trends in computing, such as the introduction of 64-bit processors, multi-core processors, and advanced operating systems. Such memory systems may include one or more memory devices, such as, for example, dynamic random access memory (DRAM) devices. The cells of a typical DRAM device can retain data for a time period ranging from several seconds to tens of seconds, but to ensure that the data is properly retained and not lost, DRAM manufacturers usually specify a very low threshold for instituting a refresh operation. The specification for most modern memory systems containing DRAM devices is that the cells of the DRAM devices are refreshed once every 64 milliseconds. This means that each cell in a given DRAM device must be read out to the sense amplifier and then written back into the DRAM device at full signal strength once every 64 milliseconds. Furthermore, for some DRAM devices, to account for the effect of higher signal loss rate at higher temperature, the refresh rate is doubled when the device is operating above a standard temperature, typically above 85° C.

To simplify the task of ensuring that all DRAM cells are properly refreshed, most DRAM devices, including double data rate (DDR) and DDR2 synchronous DRAM (SDRAM) devices, have an internal refresh row address register that keeps track of the row identification (ID) of the last refreshed row. Typically, a memory controller sends a single refresh command to the DRAM device. Subsequently, the DRAM device increments the row ID in the refresh row address register and executes a sequence of standard steps (typically referred to a "row cycle") to refresh the data contained in DRAM cells of all rows with the appropriate row ID's in all of the banks in the DRAM device.

With the advent of higher capacity DRAM devices, there are more cells to refresh. Thus, to properly refresh all DRAM cells in a higher capacity DRAM device, either the refresh operations need to be performed more frequently or more

cells need to be refreshed with each refresh command. To simplify memory controller design, the choice made by DRAM device manufacturers and memory controller designers is to keep the frequency of refresh operations the same, but refresh more DRAM cells for each refresh operation for the higher capacity DRAM devices. However, one issue associated with the action of refreshing more DRAM devices for each refresh operation in the higher capacity DRAM devices is that larger electrical currents may be drawn by the higher capacity DRAM devices for each refresh operation.

As the foregoing illustrates, what is needed in the art are new techniques for refreshing multiple memory devices in a memory system. In particular, higher capacity DRAM devices that must refresh a large number of DRAM cells for each refresh command.

SUMMARY OF THE INVENTION

One embodiment sets forth an interface circuit configured to manage refresh command sequences. The interface circuit includes a system interface adapted to receive a refresh command from a memory controller, clock frequency detection circuitry configured to determine the timing for issuing staggered refresh commands to two or more memory devices coupled to the interface circuit based on the refresh command received from the memory controller, and at least two refresh command sequence outputs configured to generate the staggered refresh commands for the two or more memory devices.

BRIEF DESCRIPTION OF THE DRAWINGS

So that the manner in which the above recited features can be understood in detail, a more particular description of the invention, briefly summarized above, may be had by reference to embodiments, some of which are illustrated in the appended drawings. It is to be noted, however, that the appended drawings illustrate only typical embodiments of this invention and are therefore not to be considered limiting of its scope, for the invention may admit to other equally effective embodiments.

FIG. 1A illustrates a multiple memory device system, according to one embodiment;

FIG. 1B illustrates a memory stack, according to one embodiment;

FIG. 1C illustrates a multiple memory device system, according to one embodiment that includes both an intelligent register and a intelligent buffer;

FIG. 2 illustrates a multiple memory device system, according to another embodiment;

FIG. 3 illustrates an idealized current draw as a function of time for a refresh cycle of a single memory device that executes two internal refresh cycles for each external refresh command, according to one embodiment;

FIG. 4A illustrates current draw as a function of time for two refresh cycles, started independently and staggered by a time period of half of the period of a single refresh cycle, according to another embodiment;

FIG. 4B illustrates voltage droop as a function of a stagger offset for two refresh cycles, according to one embodiment;

FIG. 5 illustrates the start and finish times of eight independent refresh cycles, according to one embodiment;

FIG. 6 illustrates a configuration of eight memory devices refreshed by two independently controlled refresh cycles starting at times t_{S71} and t_{S72} , respectively, according to one embodiment;

3

FIG. 7 illustrates a configuration of eight memory devices refreshed by four independently controlled refresh cycles starting at times t_{ST1} , t_{ST2} , t_{ST3} and t_{ST4} , respectively, according to another embodiment;

FIG. 8 illustrates a configuration of sixteen memory devices refreshed by eight independently controlled refresh cycles t_{ST1} , t_{ST2} , t_{ST3} and t_{ST4} , t_{ST5} , t_{ST6} , t_{ST7} and t_{ST8} , respectively, according to one embodiment;

FIG. 9 illustrates the octal configuration of the memory devices of FIG. 8 implemented within the multiple memory device system of FIG. 1A, according to one embodiment;

FIG. 10A is a flowchart of method steps for configuring, calculating, and generating the timing and assertion of two or more refresh commands, according to one embodiment;

FIG. 10B depicts a series of operations for calculating refresh stagger times for a given configuration.

FIG. 11 is a flowchart of method steps for configuring, calculating, and generating the timing and assertion of two or more refresh commands continuously and asynchronously, according to one embodiment;

FIG. 12 illustrates the interface circuit of FIG. 1A with refresh command outputs adapted to connect to a plurality of memory devices, such as the memory devices of FIG. 1A, according to one embodiment;

FIG. 13 is an exemplary illustration of a 72-bit ECC DIMM based upon industry-standard DRAM devices arranged vertically into stacks and horizontally into an array of stacks, according to one embodiment; and

FIG. 14 is a conceptual illustration of a computer platform including an interface circuit.

DETAILED DESCRIPTION

Illustrative information will now be set forth regarding various optional architectures and features of different embodiments with which the foregoing frameworks may or may not be implemented, per the desires of the user. It should be strongly noted that the following information is set forth for illustrative purposes and should not be construed as limiting in any manner. Any of the following features may be optionally incorporated with or without the other features described.

FIG. 1A illustrates a multiple memory device system 100, according to one embodiment. As shown, the multiple memory device system 100 includes, without limitation, a system device 106 coupled to an interface circuit 102, which is, in turn, coupled to a plurality of physical memory devices 104A-N. The memory devices 104A-N may be any type of memory devices. For example, in various embodiments, one or more of the memory devices 104A, 104B, 104N may include a monolithic memory device. For instance, such monolithic memory device may take the form of dynamic random access memory (DRAM). Such DRAM may take any form including, but not limited to synchronous (SDRAM), double data rate synchronous (DDR DRAM, DDR2 DRAM, DDR3 DRAM, etc.), quad data rate (QDR DRAM), direct Rambus (DRDRAM), fast page mode (FPM DRAM), video (VDRAM), extended data out (EDO DRAM), burst EDO (BEDO DRAM), multibank (MDRAM), synchronous graphics (SGRAM), and/or any other type of DRAM. Of course, one or more of the memory devices 104A, 104B, 104N may include other types of memory such as magnetic random access memory (MRAM), intelligent random access memory (IRAM), distributed network architecture (DNA) memory, window random access memory (WRAM), flash memory (e.g. NAND, NOR, or others, etc.), pseudostatic random access memory (PSRAM), wetware memory, and/or

4

any other type of memory device that meets the above definition. In some embodiments, each of the memory devices 104A-N is a separate memory chip. For example, each may be a DDR2 DRAM.

In some embodiments, the any of the memory devices 104A-N may itself be a group of memory devices, or may be a group in the physical orientation of a stack. For example, FIG. 1B shows a memory device 130 which is comprised of a group of DRAM memory devices 132A-132N all electrically interconnected to each other and an intelligent buffer 133. In alternative embodiments, the intelligent buffer 133 may include the functionality of interface circuit 102. Further, the memory device 130 may be included in a DIMM (dual in-line memory module) or other type of memory module.

The memory devices 1032A-N may be any type of memory devices. Furthermore, in some embodiments, the memory devices 104A-N may be symmetrical, meaning each has the same capacity, type, speed, etc., while in other embodiments they may be asymmetrical. For ease of illustration only, three such memory devices are shown, 104A, 104B, and 104N, but actual embodiments may use any plural number of memory devices. As will be discussed below, the memory devices 104A-N may optionally be coupled to a memory module (not shown), such as a DIMM.

The system device 106 may be any type of system capable of requesting and/or initiating a process that results in an access of the memory devices 104A-N. The system device 106 may include a memory controller (not shown) through which the system device 106 accesses the memory devices 104A-N.

The interface circuit 102 may include any circuit or logic capable of directly or indirectly communicating with the memory devices 104A-N, such as, for example, an interface circuit advanced memory buffer (AMB) chip or the like. The interface circuit 102 interfaces a plurality of signals 108 between the system device 106 and the memory devices 104A-N. The signals 108 may include, for example, data signals, address signals, control signals, clock signals, and the like. In some embodiments, all of the signals 108 communicated between the system device 106 and the memory devices 104A-N are communicated via the interface circuit 102. In other embodiments, some other signals, shown as signals 110, are communicated directly between the system device 106 (or some component thereof, such as a memory controller or an AMB) and the memory devices 104A-N, without passing through the interface circuit 102. In some embodiments, the majority of signals are communicated via the interface circuit 102, such that $L > M$.

As will be explained in greater detail below, the interface circuit 102 presents to the system device 106 an interface to emulate memory devices which differ in some aspect from the physical memory devices 104A-N that are actually present within system 100. The terms “emulating,” “emulated,” “emulation,” and the like are used herein to signify any type of emulation, simulation, disguising, transforming, converting, and the like, that results in at least one characteristic of the memory devices 104A-N appearing to the system device 106 to be different than the actual, physical characteristic of the memory devices 104A-N. For example, the interface circuit 102 may tell the system device 106 that the number of emulated memory devices is different than the actual number of physical memory devices 104A-N. In various embodiments, the emulated characteristic may be electrical in nature, physical in nature, logical in nature, pertaining to a protocol, etc. An example of an emulated electrical characteristic might be a signal or a voltage level. An example of an emulated physical characteristic might be a number of

5

pins or wires, a number of signals, or a memory capacity. An example of an emulated protocol characteristic might be timing, or a specific protocol such as DDR3.

In the case of an emulated signal, such signal may be an address signal, a data signal, or a control signal associated with an activate operation, pre-charge operation, write operation, mode register set operation, refresh operation, etc. The interface circuit 102 may emulate the number of signals, type of signals, duration of signal assertion, and so forth. In addition, the interface circuit 102 may combine multiple signals to emulate another signal.

The interface circuit 102 may present to the system device 106 an emulated interface, for example, a DDR3 memory device, while the physical memory devices 104A-N are, in fact, DDR2 memory devices. The interface circuit 102 may emulate an interface to one version of a protocol, such as DDR2 with 3-3-3 latency timing, while the physical memory chips 104A-N are built to another version of the protocol, such as DDR with 5-5-5 latency timing. The interface circuit 102 may emulate an interface to a memory having a first capacity that is different than the actual combined capacity of the physical memory devices 104A-N.

An emulated timing signal may relate to a chip enable or other refresh signal. Alternatively, an emulated timing signal may relate to the latency of, for example, a column address strobe latency (t_{CAS}), a row address to column address latency (t_{RCD}), a row precharge latency (t_{RP}), an activate to precharge latency (t_{RAS}), and so forth.

The interface circuit 102 may be operable to receive a signal 107 from the system device 106 and communicate the signal 107 to one or more of the memory devices 104A-N after a delay (which may be hidden from the system device 106). In one embodiment, such a delay may be fixed, while in other embodiments, the delay may be variable. If variable, the delay may depend on e.g. a function of the current signal or a previous signal, a combination of signals, or the like. The delay may include a cumulative delay associated with any one or more of the signals. The delay may result in a time shift of the signal 107 forward or backward in time with respect to other signals. Different delays may be applied to different signals. The interface circuit 102 may similarly be operable to receive the signal 108 from one of the memory devices 104A-N and communicate the signal 108 to the system device 106 after a delay.

The interface circuit 102 may take the form of, or incorporate, or be incorporated into, a register, an AMB, a buffer, or the like, and may comply with JEDEC standards, and may have forwarding, storing, and/or buffering capabilities.

In one embodiment, the interface circuit 102 may perform multiple operations when a single operation is commanded by the system device 106, where the timing and sequence of the multiple operations are performed by the interface circuit 102 to the one or more of the memory devices without the knowledge of the system device 106. One such operation is a refresh operation. In the situation where the refresh operations are issued simultaneously, a large parallel load is presented to the power supply. To alleviate this load, multiple refresh operations could be staggered in time, thus reducing instantaneous load on the power supply. In various embodiments, the multiple memory device system 100 shown in FIG. 1A may include multiple memory devices 104A-N capable of being independently refreshed by the interface circuit 102. The interface circuit 102 may identify one or more of the memory devices 104A-N which are capable of being refreshed independently, and perform the refresh operation on those memory devices. In yet another embodiment, the multiple memory device system 100 shown in FIG. 1A

6

includes the memory devices 104A-N which may be physically oriented in a stack, with each of the memory devices 104A-N capable of read/write a single bit. For example, to implement an eight-bit wide memory in a stack, eight one-bit wide memory devices 104A-N could be arranged in a stack of eight memory devices. In such a case, it may be desirable to control the refresh cycles of each of the memory devices 104A-N independently.

The interface circuit 102 may include one or more devices which together perform the emulation and related operations. In various embodiments, the interface circuit may be coupled or packaged with the memory devices 104A-N, or with the system device 106 or a component thereof, or separately. In one embodiment, the memory devices and the interface circuit are coupled to a DIMM. In alternative embodiments, the memory devices 104 and/or the interface circuit 102 may be coupled to a motherboard or some other circuit board within a computing device.

FIG. 1C illustrates a multiple memory device system, according to one embodiment. As shown, the multiple memory device system includes, without limitation, a host system device coupled to an host interface circuit, also known as an intelligent register circuit 102, which is, in turn, coupled to a plurality of intelligent buffer circuits 107A-107D, memory devices which is, in turn, coupled to a plurality of physical memory devices 104A-N.

FIG. 2 illustrates a multiple memory device system 200, according to another embodiment. As shown, the multiple memory device system 200 includes, without limitation, a system device 204 which communicates address, control, and clock signals 208 and data signals 210 with a memory subsystem 201. The memory subsystem 201 includes an interface circuit 202, which presents the system device 204 with an emulated interface to emulated memory, and a plurality of physical memory devices, which are shown as DRAM 06A-D. In one embodiment, the DRAM devices 206A-D are stacked, and the interface circuit 202 is electrically disposed between the DRAM devices 206A-D and the system device 204. Although the embodiments described here show the stack consisting of multiple DRAM circuits, a stack may refer to any collection of memory devices (e.g., DRAM circuits, flash memory devices, or combinations of memory device technologies, etc.).

The interface circuit 202 may buffer signals between the system device 204 and the DRAM devices 206A-D, both electrically and logically. For example, the interface circuit 202 may present to the system device 204 an emulated interface to present the memory as though the memory comprised a smaller number of larger capacity DRAM devices, although, in actuality, the memory subsystem 201 includes a larger number of smaller capacity DRAM devices 206A-D. In another embodiment, the interface circuit 202 presents to the system device 204 an emulated interface to present the memory as though the memory were a smaller (or larger) number of larger capacity DRAM devices having more configured (or fewer configured) ranks, although, in actuality, the physical memory is configured to present a specified number of ranks. Although the FIG. 2 shows four DRAM devices 206A-D, this is done for ease of illustration only. In other embodiments, other numbers of DRAM devices may be used.

As also shown in FIG. 2, the interface circuit 202 is coupled to send address, control, and clock signals 208 to the DRAM devices 206A-D via one or more buses. In the embodiment shown, each of the DRAM devices 206A-D has its own, dedicated data path for sending and receiving data signals 210 to and from the interface circuit 202. Also, in the embodiment

shown, the DRAM devices 206A-D are physically arranged on a single side of the interface circuit 202.

In one embodiment, the interface circuit 202 may be a part of the stack of the DRAM devices 206A-D. In other embodiments, the interface circuit 202 may be the bottom-most chip in the stack or otherwise disposed in or on the stack, or may be separate from the stack.

In some embodiments, the interface circuit 202 may perform operations whose relative timing and ordering are executed without the knowledge of the system device 204. One such operation is a refresh operation. The interface circuit 202 may identify one or more of the DRAM devices 206A-D that should be refreshed concurrently when a single refresh operation is issued by the system device 204 and perform the refresh operation on those DRAM devices. The methods and apparatuses capable of performing refresh operations on a plurality of memory devices are described later herein.

In general, it is desirable to manage the application of refresh operations such that the current draw and voltage levels remain within acceptable limits. Such limits may depend on the number and type of the memory devices being refreshed, physical design characteristics, and the characteristics of the system device (e.g., system devices 106, 204.)

FIG. 3 illustrates an idealized current draw as a function of time for a refresh cycle of a single memory device that executes two internal refresh cycles for each external refresh command, according to one embodiment. The single memory device may be, for example, one of the memory devices 104A-N described in FIG. 1A or one of the DRAM devices described in FIG. 2.

FIG. 3 also shows several time periods, in particular, t_{RAS} , and t_{RC} . There is relatively less current draw during the 35 ns period between 40 ns and 75 ns as compared with the 35 ns period between 5 ns and 40 ns. Thus, in the specific case of managing refresh cycles independently for two memory devices (or independently for two banks), the instantaneous current draw can be minimized by staggering the beginning of the refresh cycles of the individual memory devices. In such an embodiment, the peak current draw for two independent, staggered refresh cycles of the two memory devices is reduced by starting the second refresh cycle at about 30 ns. However, in practical (non-idealized) systems, the optimal start time for a second or any subsequent refresh cycle may be a function of time as well as a function of many variables other than time.

FIG. 4A illustrates current draw as a function of time for two refresh cycles 410 and 420, started independently and staggered by a time period of half of the period of a single refresh cycle.

FIG. 4B illustrates voltage droop on the VDD voltage supply from the nominal voltage of 1.8 volt as a function of a stagger offset for two refresh cycles, according to one embodiment. "Stagger offset" is defined herein as the difference between the starting times of the first and second refresh cycles.

A curve of the voltage droop on the VDD voltage supply from the nominal voltage of 1.8 volt as a function of the stagger offset as shown in FIG. 4B can be generated from simulation models of the interconnect components and the interconnect itself, or can be dynamically calculated from measurements. Three distinct regions become evident in this curve:

A: A local minimum in the voltage droop on the VDD voltage supply from the nominal voltage of 1.8 volt results when the refreshes are staggered by an offset such that the increasing current transient from one

refresh event counters the decreasing current transient from another refresh event. The positive slew rate from one refresh produces destructive interference with the negative slew rate from another refresh, thus reducing the effective load.

B: The best case, namely when the droop is minimum, occurs when the current draw profiles have almost zero overlap.

C: Once the waveforms are separated in time so that the refresh cycles do not overlap additional stagger spacing does not offer significant additional relief to the power delivery system. Consequently, thereafter, the level of voltage droop on the VDD supply voltage remains nearly constant.

As can be seen from a simple inspection, the optimal time to begin the second refresh cycle is at the point of minimum voltage droop (highest voltage), point B, which in this example is at about 110 ns. Persons skilled in the art will understand that the values used in the calculations resulting in the curve of FIG. 4B are for illustrative purposes only, and that a large number of other curves with different points of minimum voltage droop are possible, depending on the characteristics of the memory device, and the electrical characteristics of the physical design of the memory subsystem.

FIG. 5 illustrates the start and finish times of eight independent refresh cycles, according to one embodiment of the present application. The optimization of the start times of successive independent refresh cycles may be accomplished by circuit simulation (e.g., SPICE™ or H-SPICE as sold by Cadence Design Systems) or with logic-oriented timing analysis tools (e.g. Verilog™ as sold by Cadence Design Systems). Alternatively, the start times of the independent refresh cycles may be optimized dynamically through implementation of a dynamic parameter extraction capability. For example, the interface circuit 202 may contain a clock frequency detection circuit that the interface circuit 202 can use to determine the optimal timing for the independent refresh cycles. In the example of FIG. 5, the first independently controlled duple of cycles 510 and 511 begins at time zero. The next independently controlled duple of cycles, cycles 520 and 521, begins approximately at time 25 nS, and the next duple at approximately 37 nSec. In this example, current draw is reduced inasmuch as each next duple of refresh cycles does not begin until such time as the peak current draw of the previous duple has passed. This simplified regime is for illustrative purposes, and one skilled in the art will recognize that other regimes would emerge depending on the characteristic shape of the current draw during a refresh cycle.

In some embodiments, multiple instances of a memory device may be organized to form memory words that are longer than a single instance of the aforementioned memory device. In such a case, it may be convenient to control the independent refresh cycles of the multiple instances of the memory device that form such a memory word with multiple independently controlled memory refresh commands, with a separate refresh command sequence corresponding to each different instance of the memory device.

FIG. 6 illustrates a configuration of eight memory devices refreshed by two independently controlled refresh cycles starting at times t_{S71} and t_{S72} , respectively, according to one embodiment. The motivation for the refresh schedule is to minimize voltage droop while completing all refresh operations with the allotted time window, as per JEDEC specifications.

As shown, the eight memory devices are organized into two DRAM stacks, and each DRAM stack is driven by two independently controllable refresh command sequences. The

9

memory devices labeled R0B01[7:4], R0B01[3:0], R1B45[7:4], and R1B45[3:0] are refreshed by refresh cycle t_{ST1} , while the remaining memory devices are refreshed by the refresh cycle t_{ST2} .

FIG. 7 illustrates a configuration of eight memory devices refreshed by four independently controlled refresh cycles starting at t_{ST1} , t_{ST2} , t_{ST3} and t_{ST4} , respectively, according to another embodiment. Such a configuration is referred to herein as a “quad configuration,” and the stagger offsets in this configuration are referred to as “quad-stagger.” The quad-stagger allows for four independent stagger times distributed over eight devices, thus spreading out the total current draw and lowering large slews that may result from simultaneous activation of refresh cycles in all eight DRAM devices.

FIG. 8 illustrates a configuration of sixteen memory devices refreshed by eight independently controlled refresh cycles, according to yet another embodiment. Such a configuration is referred to herein as an “octal configuration.” The motivation for this stagger schedule is the same as for the previously mentioned dual and quad configurations, however in the octal configuration it is not possible to complete all refresh operation on all eight memories within the window unless the operations are bunched up more closely than in the quad or dual cases.

FIG. 9 illustrates the octal configuration of the memory devices of FIG. 8 implemented within the multiple memory device system 100 of FIG. 1A, according to one embodiment. As previously described, the system device 106 is connected to the interface circuit 102, which, in turn, is connected to the memory devices 104A-N. As shown in FIG. 9, there are four independently controllable refresh command sequence outputs of block 930. Outputs of R0 are independently controllable refresh command sequences. Also, outputs of R1 are independently controllable refresh command sequences. The blocks 930, 940, implement their respective functionalities using a combination of logic gates, transistors, finite state machines, programmable logic or any technique capable of operating on or delaying logic or analog signals.

The techniques and exemplary embodiments for how to independently control refresh command sequences to a plurality of memory devices using an interface circuit have now been disclosed. The following describes various techniques for calculating the timing of assertions of the refresh command sequences.

FIG. 10A is a flowchart of method steps for configuring, calculating, and generating the timing and assertion of two or more refresh command sequences, according to one embodiment. Although the method is described with respect to the system of FIG. 1A, persons skilled in the art will understand that any system configured to perform the method steps, in any order, is within the scope of the claims. As shown in FIG. 10A, the method includes the steps of analyzing the connectivity of the refresh command sequences between the memory devices 104A-N and the interface circuit 102 outputs, calculating the timing of each of the independently controlled refresh command sequences, and asserting each of the refresh command sequences at the calculated time. In exemplary embodiments, one or more of the steps of FIG. 10A are performed in the logic embedded in the interface circuit 102. In another embodiment one or more of the steps of FIG. 10A are performed in the logic embedded in the interface circuit 102 while any remaining steps of FIG. 10A are performed in the intelligent buffer 133.

In one embodiment, analyzing the connectivity of the refresh command sequences between the memory devices 104A-N and the interface circuit 102 outputs is performed statically, prior to applying power to the system device 106.

10

Any number of characteristics of the system device 106, motherboard, trace-length, capacitive loading, memory type, interface circuit output buffers, or other physical design characteristics, may be used in an analysis or simulation in order to analyze or optimize the timing of the plurality of independently controllable refresh command sequences.

In another embodiment, analyzing the connectivity of the refresh command sequences between the memory devices 104A-N and the interface circuit 102 outputs is performed dynamically, after applying power to the system device 106. Any number of characteristics of the system device 106, motherboard, trace-length, capacitive loading, memory type, interface circuit output buffers, or other physical design characteristics, may be used in an analysis or simulation in order to analyze or optimize the timing of the plurality of independently controllable refresh command sequences.

In some embodiments of the multiple memory device system of FIG. 1A, the physical design can have a significant impact on the current draw, voltage droop, and staggering of the multiple independently controlled refresh command sequences. A designer of a DIMM, motherboard, or system would seek to minimize spikes in current draw, the resulting voltage droop on the VDD voltage supply, and still meet the required refresh cycle time. Some rules and guidelines for the physical design of the trace lengths and capacitance for the signals 108, and for the packaging of the memory circuits 104A-104N as related to refresh staggering include:

- Reduce the inductance between intelligent buffer 133 and each memory device 132A-N, between intelligent buffer 133 and the intelligent register 102.

- Increase decoupling capacitance between VDD and VSS at all levels of the PDS: PCB, BGA, substrate, wirebond, RDL and die.

- Separate the spikes in current draw by staggering the refresh times between multiple memory devices.

In another embodiment, configuring the connectivity of the refresh command sequences between the memory devices 104A-N and the interface circuit 102 outputs is performed periodically at times after application of power to the system device 106. Dynamic configuration uses a measurement unit (e.g., element 1202 of FIG. 12) that is capable of performing a series of analog and logic tests on one or more of various pins of the interface circuit 102 such that actual characteristics of the pin is measured and stored for use in refresh scheduling calculations. Examples of such characteristics include, but are not limited to timing of response at first detected voltage change, timing of response where detected voltage change crosses the logic `_1`/logic `_0` threshold value, timing of response at peak detected voltage change, duration and amplitude of response ring, operating frequency of the interface circuit and operating frequency of the DRAM devices etc.

FIG. 10B shows steps of a method to be performed periodically at some time after application of power to the system device 106. The steps include determining the connectivity characteristics of the affecting communication of the refresh commands, determining operating conditions, including one or more temperatures, determining the configuration of the memory (e.g. size, number of ranks, memory word organization, etc.), calculating the refresh timing for initialization, and calculating refresh timing for the operation phase. Similarly to the method of 10A, the method of 10B may be applied repeatedly, beginning at any step, in an autonomous fashion or based on any technically feasible event, such as a power-on reset event or the receipt of a time-multiplexed or other signal, a logical combination of signals, a combination of signals and

11

stored state, a command or a packet from any component of the host system, including the memory controller.

In embodiments where one or more temperatures are measured, the calculation of the refresh timing considers not only the measured temperatures, but also the manufacturer's specifications of the DRAMs

FIG. 11 is a flowchart of method steps for analysing, calculating, and generating the timing and assertion of two or more refresh command sequences continuously and asynchronously, according to one embodiment. Although the method is described with respect to the systems of FIGS. 1A, 1B, 1C, and FIG. 12, persons skilled in the art will understand that any system configured to implement the method steps in any order, is within the scope of the claims. As shown in FIG. 11, the method includes the steps of continuously and asynchronously analysing the connectivity affecting the assertion of refresh commands between the memory devices 104A-N and the interface circuit 102 outputs, continuously and asynchronously calculating the timing of each of the independently controlled refresh command sequences, and continuously and asynchronously scheduling the assertion of each of the refresh command sequences at the calculated time. In one embodiment, the method steps of FIG. 11 may be implemented in hardware. Those skilled in the art will recognize that physical characteristics such as capacitance, resistance, inductance and temperature may vary slightly with time and during operation, and such variations may affect scheduling of the refresh commands. Moreover, during operation, the assertion of refresh commands is intended to continue on a schedule that is not in violation of any schedule required by the DRAM manufacturer, therefore the step of calculating timing of refresh command sequences and may operate concurrently with the step of asserting refresh command sequences.

FIG. 12 illustrates the interface circuit 102 of FIG. 1A with refresh command sequence outputs 1201 adapted to connect to a plurality of memory devices, such as the memory devices 104A-N of FIG. 1A, according to one embodiment. In this embodiment, each of a measurement unit 1202, a calculation unit 1204, and a scheduler 1206 is configured to operate continuously and asynchronously.

The measurement unit 1202 is configured to generate signals 1205 and to sample analog values of inputs 1203 either autonomously at some time after power-on or upon receiving a command from the system device 106. The measurement unit 1202 also is operable to determine the configuration of the memory devices 104A-N (not shown). The configuration determination and measurements are communicated to the calculation unit 1204. The calculation unit 1204 analyses the measurements received from the measurement unit 1202 and calculates the optimized timing for staggering the refresh command sequences, as previously described herein.

Understanding the use of the disclosed techniques for managing refresh commands, there are many apparent embodiments based upon industry-standard configurations of DRAM devices.

FIG. 13 is an exemplary illustration of a 72-bit ECC (error-correcting code) DIMM based upon industry-standard DRAM devices 1310 arranged vertically into stacks 1320 and horizontally into an array of stacks, according to one embodiment. As shown, the stacks of DRAM devices 1320 are organized into an array of stacks of sixteen 4-bit wide DRAM devices 1310 resulting in a 72-bit wide DIMM. Persons skilled in the art will understand that many configurations of the ECC DIMM of FIG. 13 may be possible and envisioned. A few of the exemplary configurations are further described in the following paragraphs.

12

In another embodiment, the configuration contains N DRAM devices, each of capacity M that—in concert with the interface circuit(s) 1470—emulates one DRAM device, each of capacity N*M. In a system with a system device 1420 designed to interface with a DRAM device of capacity N*M, the system device will allow for a longer refresh cycle time than it would allow to each DRAM device of capacity M. In this configuration, when a refresh command is issued by the system device to the interface circuit, the interface circuit will stagger N numbers of refresh cycles to the N numbers of DRAM devices. In one optional feature, the interface circuit may use a user-programmable setting or a self calibrated frequency detection circuit to compute the optimal stagger spacing between each of the N numbers of refresh cycles to each of the N numbers of DRAM devices. The result of the computation is minimized voltage droop on the power delivery network and functional correctness in that the entire sequence of N staggered refresh events are completed within the refresh cycle time expected by the system device. For example, a configuration may contain 4 DRAM devices, each 1 gigabit in capacity that an interface circuit may use to emulate one DRAM device that is 4 gigabit in capacity. In a JEDEC compliant DDR2 memory system, the defined refresh cycle time for the 4 gigabit device is 327.5 nanoseconds, and the defined refresh cycle time for the 1 gigabit device is 127.5 nanoseconds. In this specific example, the interface circuit may stagger refresh commands to each of the 1 gigabit DRAM devices with spacing that is carefully selected based on the operating characteristics of the system, such as temperature, frequency, and voltage levels, while still ensuring that the entire sequence is complete within the 327.5 ns expected by the memory controller.

In another embodiment, the configuration contains 2*N DRAM devices, each of capacity M that—in concert with the interface circuit(s) 1470—emulates two DRAM devices, each of capacity N*M. In a system with a system device 1420 designed to interface with a DRAM device of capacity N*M, the system device will allow for a longer refresh cycle time than it would allow to each DRAM device of capacity M. In this configuration, when a refresh command is issued by the system device to the interface circuit to refresh one of the two emulated DRAM devices, the interface circuit will stagger N numbers of refresh cycles to the N numbers of DRAM devices. In one optional feature when the system device issues the refresh command to the interface circuit to refresh both of the emulated DRAM devices, the interface circuit will stagger 2*N numbers of refresh cycles to the 2*N numbers of DRAM devices to minimize voltage droop on the power delivery network, while ensuring that the entire sequence completes within the allowed refresh cycle time of the single emulated DRAM device of capacity N*M.

As can be understood from the above discussion of the several disclosed configurations of the embodiments of FIG. 13, there exist at least as many refresh command sequence spacing possibilities as there are possible configurations of DRAM memory devices on a DIMM.

The response of a memory device to one or more time-domain pulses can be represented in the frequency domain as a spectrograph. Similarly, the power delivery system of a motherboard has a natural frequency domain response. In one embodiment, the frequency domain response of the power delivery system is measured, and the timing of refresh command sequence for a DIMM configuration is optimized to match the natural frequency response of the power delivery subsystem. That is, the frequency domain characteristics between the power delivery system and the memory device on the DIMM are anti-correlated such that the energy of the

13

pulse stream of refresh command sequences spread the energy of the pulse stream out over a broad spectral range. Accordingly one embodiment of a method for optimizing memory refresh command sequences in a DIMM on a motherboard is to measure and plot the frequency domain response of the motherboard power delivery system, measure and plot the frequency domain response of the memory devices, superimpose the two frequency domain plots and define a refresh command sequence pulse train which frequency domain response, when superimposed on the aforementioned plots results in a flatter frequency domain response.

FIG. 14 is a conceptual illustration of a computer platform 1400 configured to implement one or more aspects of the embodiments. As an option, the contents of FIG. 14 may be implemented in the context of the architecture and/or environment of the figures previously described herein. Of course, however, such contents may be implemented in any desired environment.

As shown, the computer platform 1400 includes, without limitation, a system device 1420 (e.g., a motherboard), interface circuit(s) 1470, and memory module(s) 1480 that include physical memory devices 1481 (e.g., physical memory devices, such as the memory devices 104A-N shown in FIG. 1A). In one embodiment, the memory module(s) 1480 may include DIMMs. The physical memory devices 1481 are connected directly to the system 1420 by way of one or more sockets.

In one embodiment, the system device 1420 includes a memory controller 1421 designed to the specifics of various standards, in particular the standard defining the interfaces to JEDEC-compliant semiconductor memory (e.g., DRAM, SDRAM, DDR2, DDR3, etc.). The specifications of these standards address physical interconnection and logical capabilities. FIG. 14 depicts the system device 1420 further including logic for retrieval and storage of external memory attribute expectations 1422, memory interaction attributes 1423, a data processing engine 1424, various mechanisms to facilitate a user interface 1425, and the system basic Input/Output System (BIOS) 1426.

In various embodiments, the system device 1420 may include a system BIOS program capable of interrogating the physical memory module 1480 (e.g., DIMMs) as a mechanism to retrieve and store memory attributes. Furthermore, in external memory embodiments, JEDEC-compliant DIMMs include an EEPROM device known as a Serial Presence Detect (SPD) 1482 where the DIMM's memory attributes are stored. It is through the interaction of the system BIOS 1426 with the SPD 1482 and the interaction of the system BIOS 1426 with the physical attributes of the physical memory devices 1481 that the various memory attribute expectations and memory interaction attributes become known to the system device 1420. Also optionally included on the memory module(s) 1480 are an address register logic 1483 (e.g. JEDEC standard register, register, etc.) and data buffer(s) and logic 1484.

In various embodiments, the compute platform 1400 includes one or more interface circuits 1470, electrically disposed between the system device 1420 and the physical memory devices 1481. The interface circuits 1470 may be physically separate from the DIMM, may be placed on the memory module(s) 1480, or may be part of the system device 1420 (e.g., integrated into the memory controller 1421, etc.)

Some characteristics of the interface circuit(s) 1470, in accordance with an optional embodiment, includes several system-facing interfaces such as, for example, a system address signal interface 1471, a system control signal interface 1472, a system clock signal interface 1473, and a system

14

data signal interface 1474. Similarly, the interface circuit(s) 1470 may include several memory-facing interfaces such as, for example, a memory address signal interface 1475, a memory control signal interface 1476, a memory clock signal interface 1477, and a memory data signal interface 1478.

In additional embodiments, an additional characteristic of the interface circuit(s) 1470 is the optional presence of one or more sub-functions of emulation logic 1430. The emulation logic 1430 is configured to receive and optionally store electrical signals (e.g., logic levels, commands, signals, protocol sequences, communications) from or through the system-facing interfaces 1471-1474 and to process those signals. In particular, the emulation logic 1430 may contain one or more sub functions (e.g., power management logic 1432 and delay management logic 1433) configured to manage refresh command sequencing with the physical memory devices 1481.

Aspects of embodiments of the invention can be implemented in hardware or software or both, with the software being delivered as a program product for use with a computer system. The program(s) of the program product defines functions of the embodiments (including the methods described herein) and can be contained on a variety of computer-readable storage media. Illustrative computer-readable storage media include, but are not limited to: (i) non-writable storage media (e.g., read-only memory devices within a computer such as CD-ROM disks readable by a CD-ROM drive) on which information is permanently stored; and (ii) writable storage media (e.g., floppy disks within a diskette drive or hard-disk drive) on which alterable information is stored. Such computer-readable storage media, when carrying computer-readable instructions that direct the functions disclosed herein, are yet further embodiments.

While the foregoing is directed to exemplary embodiments, other and further embodiments may be devised without departing from the basic scope thereof.

We claim:

1. A memory module comprising:

2*N dynamic random access memory (DRAM) devices each having a capacity of M, wherein the 2*N DRAM devices comprising:

a first group of N DRAM devices; and

a second group of N DRAM devices, wherein each of the N DRAM devices in the first group shares a distinct refresh control signal with a respective DRAM device in the second group;

emulation logic configured to emulate an interface protocol of two emulated DRAM devices each having a capacity of N*M, wherein a first of the two emulated DRAM devices includes the N DRAM devices from the first group, and a second of the two emulated DRAM devices includes the N DRAM devices from the second group;

an interface circuit configured to receive from a memory controller a refresh command for the two emulated DRAM devices, the interface circuit including:

a calculation unit configured to determine offset timings for N independently controlled staggered refresh cycles, wherein exactly one DRAM device from the first group and one DRAM device from the second group are refreshed in each of the independently controlled staggered refresh cycles, the offset timings providing timings of each of the independently controlled staggered refresh cycles; and

a scheduler configured to order independently controlled staggered refresh commands directed to the

15

2*N DRAM devices in the first and the second groups based on the offset timings determined by the calculation unit.

2. The memory module of claim 1, wherein the interface circuit further comprises:

a measurement unit configured to perform analog signal measurements and to determine a configuration of DRAM devices;

wherein the calculation unit is configured to determine the independently controlled staggered refresh cycles based on measurements received from the measurement unit and the refresh command received from the memory controller.

3. The memory module of claim 2, wherein the measurement unit is further configured to perform a series of analog measurements to determine analog pin characteristics of DRAM devices.

4. The memory module of claim 2, wherein the measurement unit is further configured to perform a series of analog measurements to determine timing responses at selected logic threshold levels.

5. The memory module of claim 2, wherein the measurement unit is further configured to perform a series of analog measurements to determine a timing response at a peak detected voltage change, a duration and a response ring.

6. The memory module of claim 2, wherein the measurement unit is further configured to perform a series of measurements to determine an operating temperature of each of the DRAM devices.

7. The memory module of claim 1, wherein the calculation unit is configured to determine the offset timings for two independently controlled staggered refresh cycles for four DRAM devices coupled to the interface circuit, wherein the two independently controlled staggered refresh cycles are staggered by an amount of time equal to approximately half a single refresh cycle associated with the refresh command received from the memory controller, and wherein each of the two independently controlled staggered refresh cycles refreshes a DRAM device in the first group and a DRAM device in the second group.

8. The memory module of claim 1, wherein the calculation unit is configured to determine the offset timings for four independently controlled staggered refresh cycles for eight DRAM devices coupled to the interface circuit, wherein the four independently controlled staggered refresh cycles are staggered by an amount of time equal to approximately a quarter of a single refresh cycle associated with the refresh command received from the memory controller, and wherein each of the four independently controlled staggered refresh cycles refreshes a DRAM device in the first group and a DRAM device in the second group.

9. The memory module of claim 1, wherein the calculation unit is configured to determine the offset timings for eight independently controlled staggered refresh cycles for sixteen DRAM devices coupled to the interface circuit, wherein the eight independently controlled staggered refresh cycles are staggered by an amount of time equal to approximately an eighth of a single refresh cycle associated with the refresh command received from the memory controller and wherein each of the eight independently controlled staggered refresh cycles refreshes a DRAM device in the first group and a DRAM device in the second.

10. The memory module of claim 1, wherein the calculation unit is configured to dynamically determine, at a time subsequent to applying power to the dynamic random access

16

memory devices, the offset timings for the independently controlled staggered refresh cycles that minimize instantaneous power supply load.

11. The memory module of claim 1, wherein the interface circuit further comprises a memory address signal interface, a memory control signal interface, a memory clock signal interface, and a memory data signal interface.

12. The memory module of claim 1, wherein each of the independently controlled staggered refresh cycles is transmitted to exactly two DRAM devices in a group.

13. The memory module of claim 12, wherein the interface circuit is integrated within one of the first group or second group.

14. The memory module of claim 13, wherein the interface circuit comprises an intelligent buffer chip.

15. The memory module of claim 14, wherein the memory module is a dual in-line memory module.

16. The memory module of claim 1, wherein the independently controlled staggered refresh cycles or the scheduling are performed asynchronously.

17. The memory module of claim 16, wherein the memory module is a dual in-line memory module.

18. The memory module of claim 1, wherein a time difference between the timings of each of the N independently controlled staggered refresh cycles differs for each of the independently controlled staggered refresh cycles.

19. A memory module comprising:

2*N dynamic random access memory (DRAM) devices each having a capacity of M, wherein the 2*N DRAM devices comprise:

a first group of N DRAM devices; and

a second group of N DRAM devices, wherein each of the N DRAM devices in the first group shares a distinct refresh control signal with a respective DRAM device in the second group; and

an interface circuit comprising:

emulation logic configured to emulate an interface protocol of two emulated DRAM devices each having a capacity of N*M, wherein a first of the two emulated DRAM devices includes the N DRAM devices from the first group, and a second of the two emulated DRAM devices includes the N DRAM devices from the second group;

a calculation unit configured to determine offset timings for N independently controlled staggered refresh cycles, wherein exactly one DRAM device from the first group and one DRAM device from the second group are refreshed in each of the independently controlled staggered refresh cycles, the offset timings providing timings of each of the independently controlled staggered refresh cycles; and

a scheduler configured to order independently controlled staggered refresh commands directed to the 2*N DRAM devices based on the offset timings determined by the calculation unit.

20. The memory module of claim 19, wherein the interface circuit further comprises:

a measurement unit configured to perform analog signal measurements and to determine a configuration of DRAM devices;

wherein the calculation unit is configured to determine the independently controlled staggered refresh cycles based on measurements received from the measurement unit and the refresh command received from the memory controller.

21. The memory module of claim 19, wherein the calculation unit is configured to dynamically determine, at a time

17

subsequent to applying power to the dynamic random access memory devices, the offset timings for the independently controlled staggered refresh cycles that minimize instantaneous power supply load.

- 22. A sub-system comprising:
 - a printed circuit board;
 - a memory module comprising:
 - 2*N dynamic random access memory (DRAM) devices each having a capacity of M, wherein the 2*N DRAM devices comprise:
 - a first group of N DRAM devices; and
 - a second group of N DRAM devices, wherein each of the N DRAM devices in the first group shares a distinct refresh control signal with a respective DRAM device in the second group; and
 - an interface circuit comprising:
 - emulation logic configured to emulate an interface protocol of two emulated DRAM devices each having a capacity of N*M, wherein a first of the two emulated DRAM devices includes the N DRAM devices from the first group, and a second of the two emulated DRAM devices includes the N DRAM devices from the second group;
 - a calculation unit configured to determine offset timings for N independently controlled staggered refresh cycles, wherein exactly one DRAM device from the first group and one DRAM device from the second group are refreshed in each of the independently con-

18

- trolled staggered refresh cycles, the offset timings providing timings of each of the independently controlled staggered refresh cycles; and
- a scheduler configured to order independently controlled staggered refresh commands directed to the 2*N DRAM devices based on the offset timings determined by the calculation unit,
 - wherein the memory module and the interface circuit are mounted to the printed circuit board, and the memory module is electrically coupled to the interface circuit.
- 23. The sub-system of claim 22, wherein the interface circuit further comprises:
 - a measurement unit configured to perform analog signal measurements and to determine a configuration of DRAM devices;
 - wherein the calculation unit is configured to determine the independently controlled staggered refresh cycles based on measurements received from the measurement unit and the refresh command received from the memory controller.
- 24. The sub-system of claim 22, wherein the calculation unit is configured to dynamically determine, at a time subsequent to applying power to the dynamic random access memory devices, the offset timings for the independently controlled staggered refresh cycles that minimize instantaneous power supply load.

* * * * *

UNITED STATES PATENT AND TRADEMARK OFFICE
CERTIFICATE OF CORRECTION

PATENT NO. : 8,566,516 B2
APPLICATION NO. : 11/929631
DATED : October 22, 2013
INVENTOR(S) : Keith R. Schakel et al.

Page 1 of 1

It is certified that error appears in the above-identified patent and that said Letters Patent is hereby corrected as shown below:

In the Specification:

Column 1, line 18, after “matter” please insert -- of --; and

In the Claims:

Column 15, line 64, Claim 9, please delete “second.” and insert therefor -- second group. --.

Signed and Sealed this
Twenty-fifth Day of February, 2014

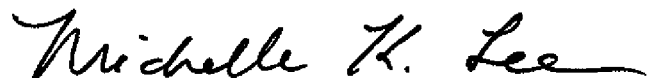

Michelle K. Lee
Deputy Director of the United States Patent and Trademark Office

UNITED STATES PATENT AND TRADEMARK OFFICE
CERTIFICATE OF CORRECTION

PATENT NO. : 8,566,516 B2
APPLICATION NO. : 11/929631
DATED : October 22, 2013
INVENTOR(S) : Schakel et al.

Page 1 of 1

It is certified that error appears in the above-identified patent and that said Letters Patent is hereby corrected as shown below:

On the Title Page:

The first or sole Notice should read --

Subject to any disclaimer, the term of this patent is extended or adjusted under 35 U.S.C. 154(b) by 534 days.

Signed and Sealed this
Twenty-third Day of May, 2017

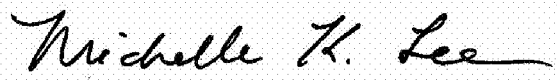

Michelle K. Lee
Director of the United States Patent and Trademark Office