

(12) **United States Patent**
Lee et al.

(10) **Patent No.:** **US 10,268,608 B2**
(45) **Date of Patent:** ***Apr. 23, 2019**

(54) **MEMORY MODULE WITH TIMING-CONTROLLED DATA PATHS IN DISTRIBUTED DATA BUFFERS**

(71) Applicant: **Netlist, Inc.**, Irvine, CA (US)

(72) Inventors: **Hyun Lee**, Ladera Ranch, CA (US);
Jayesh R. Bhakta, Cerritos, CA (US)

(73) Assignee: **NETLIST, INC.**, Irvine, CA (US)

(*) Notice: Subject to any disclaimer, the term of this patent is extended or adjusted under 35 U.S.C. 154(b) by 0 days.

This patent is subject to a terminal disclaimer.

(21) Appl. No.: **15/820,076**

(22) Filed: **Nov. 21, 2017**

(65) **Prior Publication Data**
US 2018/0095908 A1 Apr. 5, 2018

Related U.S. Application Data

(63) Continuation of application No. 15/426,064, filed on Feb. 7, 2017, now Pat. No. 9,824,035, which is a (Continued)

(51) **Int. Cl.**
G06F 3/00 (2006.01)
G06F 12/00 (2006.01)
(Continued)

(52) **U.S. Cl.**
CPC **G06F 13/1673** (2013.01); **G06F 1/10** (2013.01); **G06F 3/0613** (2013.01);
(Continued)

(58) **Field of Classification Search**
None
See application file for complete search history.

(56) **References Cited**

U.S. PATENT DOCUMENTS

4,218,740 A 8/1980 Bennett et al.
4,249,253 A 2/1981 Gentili et al.
(Continued)

FOREIGN PATENT DOCUMENTS

EP 1816570 A2 8/2007
JP 09237492 9/1997
(Continued)

OTHER PUBLICATIONS

US 6,832,284 B1, 12/2004, Perego et al. (withdrawn)
(Continued)

Primary Examiner — Michael Sun
(74) *Attorney, Agent, or Firm* — Morgan, Lewis & Bockius LLP

(57) **ABSTRACT**

A memory module is operable in a memory system with a memory controller. The memory module comprises memory devices, a module control circuit, and a plurality of buffer circuits coupled between respective sets of data/strobe signal lines in a data bus and respective sets of the memory devices. Each respective buffer circuit includes a data path corresponding to each data signal line in the corresponding set of data/strobe signal lines, and a command processing circuit configured to decode module control signals from the module control circuit and to control the data path in accordance with the module control signals. The data path corresponding to the each data signal line includes at least one tristate buffer controlled by the command processing circuit and a delay circuit configured to delay a signal through the data path by an amount determined by the command processing circuit in response to at least one of the module control signals.

12 Claims, 26 Drawing Sheets

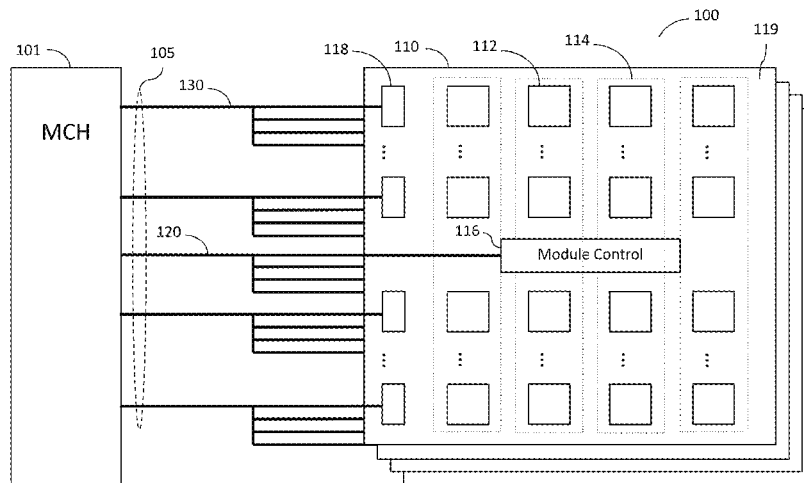

Related U.S. Application Data

continuation of application No. 14/846,993, filed on Sep. 7, 2015, now Pat. No. 9,563,587, which is a continuation of application No. 13/952,599, filed on Jul. 27, 2013, now Pat. No. 9,128,632.

(60) Provisional application No. 61/676,883, filed on Jul. 27, 2012.

(51) **Int. Cl.**

- G06F 13/00** (2006.01)
- G06F 13/16** (2006.01)
- G06F 3/06** (2006.01)
- GI1C 16/00** (2006.01)
- GI1C 5/04** (2006.01)
- GI1C 7/10** (2006.01)
- G06F 1/10** (2006.01)
- G06F 13/28** (2006.01)
- G06F 13/40** (2006.01)
- GI1C 8/18** (2006.01)
- GI1C 29/02** (2006.01)
- GI1C 8/12** (2006.01)
- GI1C 7/20** (2006.01)
- GI1C 29/04** (2006.01)

(52) **U.S. Cl.**

- CPC **G06F 3/0647** (2013.01); **G06F 3/0656** (2013.01); **G06F 3/0659** (2013.01); **G06F 3/0683** (2013.01); **G06F 13/1642** (2013.01); **G06F 13/28** (2013.01); **G06F 13/4027** (2013.01); **GI1C 5/04** (2013.01); **GI1C 7/1006** (2013.01); **GI1C 7/1066** (2013.01); **GI1C 7/1093** (2013.01); **GI1C 8/18** (2013.01); **GI1C 16/00** (2013.01); **GI1C 29/023** (2013.01); **GI1C 29/028** (2013.01); **H05K 999/99** (2013.01); **GI1C 7/109** (2013.01); **GI1C 7/20** (2013.01); **GI1C 8/12** (2013.01); **GI1C 2029/0407** (2013.01)

(56)

References Cited

U.S. PATENT DOCUMENTS

4,368,515	A	1/1983	Nielsen
4,392,212	A	7/1983	Miyasaka et al.
4,571,676	A	2/1986	Mantellina et al.
4,592,011	A	5/1986	Mantellina et al.
4,633,429	A	12/1986	Lewandowski et al.
4,670,748	A	6/1987	Williams
4,706,214	A	11/1987	Kassai
4,739,473	A	4/1988	Ng
4,866,603	A	9/1989	Chiba
4,958,322	A	9/1990	Kosugi et al.
4,961,172	A	10/1990	Shubat et al.
4,961,204	A	10/1990	Tanaka et al.
4,980,850	A	12/1990	Morgan
5,060,188	A	10/1991	Zulian et al.
5,247,643	A	9/1993	Shottan
5,272,664	A	12/1993	Alexander et al.
5,313,624	A	5/1994	Harriman
5,345,412	A	9/1994	Shiratsuchi
5,357,478	A	10/1994	Kikuda et al.
5,388,072	A	2/1995	Matick et al.
5,388,240	A	2/1995	Olderdissen et al.
5,392,252	A	2/1995	Rimpo et al.
5,426,753	A	6/1995	Moon
5,463,590	A	10/1995	Watanabe
5,483,497	A	1/1996	Mochizuki et al.
5,485,589	A	1/1996	Kocis et al.
5,495,435	A	2/1996	Sugahara
5,513,135	A	4/1996	Dell et al.
5,532,954	A	7/1996	Bechtolsheim et al.

5,537,584	A	7/1996	Miyai et al.
5,541,448	A	7/1996	Carpenter
5,572,691	A	11/1996	Koudmani
5,581,498	A	12/1996	Ludwig et al.
5,590,071	A	12/1996	Kolor et al.
5,602,999	A	2/1997	Hyatt
5,617,559	A	4/1997	Le et al.
5,630,096	A	5/1997	Zuravleff
5,638,534	A	6/1997	Mote, Jr.
5,649,159	A	7/1997	Le et al.
5,655,113	A	8/1997	Leung
5,655,153	A	8/1997	Sandorfi
5,699,542	A	12/1997	Mehta et al.
5,702,984	A	12/1997	Bertin et al.
5,703,826	A	12/1997	Hush et al.
5,717,851	A	2/1998	Yishay et al.
5,724,604	A	3/1998	Moyer
5,745,914	A	4/1998	Connolly et al.
5,729,716	A	5/1998	Lee et al.
5,764,590	A	6/1998	Iwamoto et al.
5,784,705	A	7/1998	Leung
5,802,395	A	9/1998	Connolly et al.
5,802,541	A	9/1998	Reed
5,805,520	A	9/1998	Anglada et al.
5,822,251	A	10/1998	Bruce et al.
5,905,401	A	5/1999	Sher
RE36,229	E	6/1999	Cady
5,909,388	A	6/1999	Mueller
5,926,827	A	7/1999	Dell et al.
5,926,839	A	7/1999	Katayama
5,953,215	A	9/1999	Karabatsos
5,953,280	A	9/1999	Watsui
5,958,025	A	9/1999	Sonobe
5,959,930	A	9/1999	Sakurai
5,963,464	A	10/1999	Dell et al.
5,966,736	A	10/1999	Gittinger et al.
5,973,392	A	10/1999	Senba et al.
5,974,493	A	10/1999	Okumura et al.
6,011,710	A	1/2000	Wieggers
6,018,787	A	1/2000	Ip
6,044,032	A	3/2000	Li
6,061,754	A	5/2000	Cepulis
6,070,217	A	5/2000	Connolly et al.
6,070,227	A	5/2000	Rokicki
6,097,652	A	8/2000	Roh
6,108,745	A	8/2000	Gupta et al.
6,115,278	A	9/2000	Deneroff et al.
6,134,638	A	10/2000	Olarig et al.
6,141,245	A	10/2000	Bertin
6,151,271	A	11/2000	Lee
6,154,418	A	11/2000	Li
6,154,419	A	11/2000	Shakkarwar
6,173,357	B1	1/2001	Ju
6,185,654	B1	2/2001	Van Doren
6,188,641	B1	2/2001	Uchida
6,205,516	B1	3/2001	Usami
6,209,074	B1	3/2001	Dell et al.
6,223,650	B1	5/2001	Johnson
6,226,709	B1	5/2001	Goodwin et al.
6,226,736	B1	5/2001	Niot
6,233,650	B1	5/2001	Johnson et al.
6,247,088	B1	6/2001	Seo et al.
6,260,127	B1	7/2001	Olarig et al.
6,262,938	B1	7/2001	Lee
6,317,352	B1	11/2001	Halbert et al.
6,349,051	B1	2/2002	Klein
6,381,140	B1	4/2002	Liao
6,400,637	B1	6/2002	Akamatsu et al.
6,408,356	B1	6/2002	Dell
6,414,868	B1	7/2002	Wong et al.
6,415,374	B1	7/2002	Faue et al.
6,438,062	B1	8/2002	Curtis
6,446,158	B1	9/2002	Karabatsos
6,446,184	B2	9/2002	Dell et al.
6,453,381	B1	9/2002	Yuan et al.
6,470,417	B1	10/2002	Kolor et al.
6,480,439	B2	11/2002	Tokutome et al.
6,487,102	B1	11/2002	Halbert et al.
6,502,161	B1	12/2002	Perego et al.

(56)

References Cited

U.S. PATENT DOCUMENTS

6,518,794 B2	2/2003	Coteus et al.	7,167,967 B2	1/2007	Bungo et al.	
6,526,473 B1	2/2003	Kim	7,181,591 B2	2/2007	Tsai	
6,530,007 B2	3/2003	Olarig et al.	7,191,302 B2	3/2007	Usami	
6,530,033 B1	3/2003	Raynham et al.	7,200,021 B2	4/2007	Radhuram	
6,546,476 B1	4/2003	Gillingham	7,225,303 B2	5/2007	Choi	
6,553,449 B1	4/2003	Dodd et al.	7,227,910 B2	6/2007	Lipka	
6,553,450 B1	4/2003	Dodd et al.	7,254,036 B2	8/2007	Pauley et al.	
6,618,320 B2	9/2003	Hasegawa et al.	7,266,639 B2	9/2007	Radhuram	
6,618,791 B1	9/2003	Dodd et al.	7,272,709 B2	9/2007	Zitlaw et al.	
6,621,496 B1	9/2003	Ryan	7,281,079 B2	10/2007	Bains et al.	
6,625,081 B2	9/2003	Roohparvar et al.	7,286,436 B2	10/2007	Bhakta et al.	
6,625,687 B1	9/2003	Halbert et al.	7,289,386 B2	10/2007	Bhakta et al.	
6,636,446 B2	10/2003	Lee	7,334,150 B2	2/2008	Ruckerbauer et al.	
6,636,935 B1	10/2003	Ware et al.	7,346,750 B2	3/2008	Ishikawa	
6,646,949 B1	11/2003	Ellis et al.	7,356,639 B2	4/2008	Perego et al.	
6,658,509 B1	12/2003	Bonella et al.	7,370,238 B2	5/2008	Billick et al.	
6,674,684 B1	1/2004	Shen	7,379,361 B2	5/2008	Co et al.	
6,681,301 B1	1/2004	Mehta et al.	7,437,591 B1	10/2008	Wong	
6,683,372 B1	1/2004	Wong et al.	7,461,182 B2	12/2008	Fukushima et al.	
6,697,888 B1	2/2004	Halbert et al.	7,464,225 B2	12/2008	Tsern	
6,704,910 B2	3/2004	Hong	7,471,538 B2	12/2008	Hofstra	
6,705,877 B1	3/2004	Li et al.	7,532,537 B2	5/2009	Solomon et al.	
6,717,855 B2	4/2004	Underwood	7,619,912 B2	11/2009	Bhakta et al.	
6,717,885 B2	4/2004	Lai	7,636,274 B2	12/2009	Solomon et al.	
6,721,843 B1	4/2004	Estakhri	7,730,254 B2	6/2010	Risse	
6,721,860 B2	4/2004	Klein	7,864,627 B2	1/2011	Bhakta et al.	
6,738,880 B2	5/2004	Lai et al.	7,865,674 B2	1/2011	Gower et al.	
6,742,098 B1	5/2004	Halbert et al.	7,881,150 B2	2/2011	Solomon et al.	
6,747,887 B2	6/2004	Halbert et al.	7,884,619 B1*	2/2011	Chong	G01R 31/3016 324/601
6,754,746 B1	6/2004	Leung et al.	7,916,574 B1	3/2011	Solomon et al.	
6,754,797 B2	6/2004	Wu et al.	7,990,746 B2	8/2011	Rajan	
6,785,189 B2	8/2004	Jacobs et al.	8,001,434 B1	8/2011	Lee et al.	
6,788,592 B2	9/2004	Nakata et al.	8,081,536 B1	12/2011	Solomon et al.	
6,799,252 B1	9/2004	Bauman	8,089,795 B2	1/2012	Rajan	
6,807,125 B2	10/2004	Coteus et al.	8,130,560 B1	3/2012	Rajan et al.	
6,807,650 B2	10/2004	Lamb et al.	8,189,328 B2	5/2012	Kanapathipillai	
6,813,196 B2	11/2004	Park et al.	8,214,616 B2*	7/2012	Ware	G06F 13/1684 711/104
6,832,303 B2	12/2004	Tanaka	8,233,303 B2	7/2012	Best	
6,834,014 B2	12/2004	Yoo et al.	8,244,971 B2	8/2012	Rajan	
6,854,042 B1	2/2005	Karabatsos	8,250,295 B2	8/2012	Amidi et al.	
6,880,094 B2	4/2005	La Berge	8,335,894 B1	12/2012	Rajan	
6,889,304 B2	5/2005	Perego et al.	8,417,870 B2	4/2013	Lee et al.	
6,912,615 B2	6/2005	Nicolai	8,516,185 B2	8/2013	Lee et al.	
6,912,628 B2	6/2005	Wicki et al.	8,516,188 B1	8/2013	Solomon et al.	
6,925,028 B2	8/2005	Hosokawa et al.	8,565,033 B1	10/2013	Manochararajah et al.	
6,944,694 B2	9/2005	Pax	8,689,064 B1	4/2014	Lee et al.	
6,948,084 B1	9/2005	Manapat et al.	8,756,364 B1	6/2014	Bhakta et al.	
6,950,366 B1	9/2005	Lapidus et al.	8,782,350 B2	7/2014	Lee et al.	
6,954,281 B2	10/2005	Fukuda et al.	8,856,464 B2	10/2014	Karamcheti	
6,961,281 B2	11/2005	Wong et al.	8,949,519 B2*	2/2015	Rajan	G11C 5/02 365/189.2
6,981,089 B2	12/2005	Dodd et al.	2001/0008006 A1	7/2001	Klein	
6,982,892 B2	1/2006	Lee et al.	2002/0038405 A1	3/2002	Leddige	
6,982,893 B2	1/2006	Jakobs	2002/0039323 A1*	4/2002	Tokutome	G11C 7/1066 365/233.12
6,990,043 B2	1/2006	Kuroda et al.	2002/0048195 A1	4/2002	Klein	
6,996,686 B2	2/2006	Doblar et al.	2002/0112119 A1	8/2002	Halbert et al.	
7,007,130 B1	2/2006	Holman	2003/0070052 A1	4/2003	Lai	
7,007,175 B2	2/2006	Chang et al.	2004/0098528 A1	5/2004	Janzen	
7,024,518 B2	4/2006	Halbert et al.	2004/0105292 A1	6/2004	Matsui	
7,046,538 B2	5/2006	Kinsley et al.	2005/0010737 A1	1/2005	Ware et al.	
7,047,361 B2	5/2006	Chong et al.	2005/0257109 A1	11/2005	Averbui	
7,054,179 B2	5/2006	Cogdill et al.	2005/0281096 A1	12/2005	Bhakta et al.	
7,065,626 B2	6/2006	Schumacher et al.	2006/0077731 A1*	4/2006	Ware	G11C 5/04 365/194
7,072,231 B2	7/2006	Pax	2006/0117152 A1	6/2006	Amidi et al.	
7,073,041 B2	7/2006	Dwyer et al.	2006/0179206 A1	8/2006	Brittain et al.	
7,078,793 B2	7/2006	Ruckerbauer et al.	2006/0233012 A1	10/2006	Sekiguchi et al.	
7,093,066 B2	8/2006	Klein	2006/0259711 A1	11/2006	Oh	
7,120,727 B2	10/2006	Lee et al.	2006/0262586 A1	11/2006	Solomon et al.	
7,124,260 B2	10/2006	La Berge et al.	2006/0267172 A1	11/2006	Nguyen et al.	
7,127,584 B1	10/2006	Thompson et al.	2006/0277355 A1	12/2006	Ellsberry et al.	
7,130,308 B2	10/2006	Haddock et al.	2007/0058409 A1	3/2007	Ruckerbauer	
7,130,952 B2	10/2006	Nanki et al.	2007/0064462 A1	3/2007	Matsui	
7,133,960 B1	11/2006	Thompson et al.	2007/0070669 A1	3/2007	Tsern	
7,133,972 B2	11/2006	Jeddeloh	2007/0217559 A1*	9/2007	Stott	G11C 7/1051 375/355
7,142,461 B2	11/2006	Janzen				
7,149,841 B2	12/2006	La Berge				

(56) **References Cited**

U.S. PATENT DOCUMENTS

2007/0293094	A1	12/2007	Aekins	
2008/0025137	A1	1/2008	Rajan et al.	
2008/0037412	A1*	2/2008	Geile	G06F 17/14 370/208
2008/0046631	A1	2/2008	Takaku et al.	
2008/0104352	A1	5/2008	Talbot	
2008/0162790	A1	7/2008	Im	
2009/0103387	A1	4/2009	Shau	
2009/0198924	A1	8/2009	Shaeffer et al.	
2009/0248969	A1	10/2009	Wu et al.	
2009/0296503	A1	12/2009	Chu	
2010/0070690	A1	3/2010	Amer et al.	
2010/0091540	A1	4/2010	Bhakta et al.	
2010/0125681	A1	5/2010	Patel	
2010/0228891	A1	9/2010	Talbot	
2010/0271092	A1*	10/2010	Zerbe	G06F 13/4243 327/161
2011/0016250	A1	1/2011	Lee et al.	
2011/0016269	A1	1/2011	Lee et al.	
2011/0085408	A1	4/2011	Solomon	
2011/0090749	A1	4/2011	Bhakta et al.	
2011/0125966	A1	5/2011	Amidi et al.	
2012/0256639	A1*	10/2012	Pausini	G01R 31/31709 324/613
2014/0029370	A1*	1/2014	Koshizuka	G11C 7/1051 365/233.13

FOREIGN PATENT DOCUMENTS

JP	10-092169	10/1998
JP	2000285674	10/2000
JP	2000311485	10/2000
JP	2002184176	6/2002
JP	2003007963	1/2003
JP	2008046989	2/2008

OTHER PUBLICATIONS

Non-Final Office Action, U.S. Appl. No. 13/412,243, dated Jan. 2, 2014, 20 pages.
 Non-final office action, U.S. Appl. No. 13/288,850, dated Oct. 11, 2013, 24 pages.
 Non-final office action, U.S. Appl. No. 13/411,344, dated Dec. 31, 2013, 28 pages.
 Non-final office action, U.S. Appl. No. 13/473,413, dated Nov. 17, 2011, 46 pages.
 Response to non-final office action dated Oct. 14, 2013 for U.S. Appl. No. 13/288,850, filed Jan. 13, 2014, 15 pages.
 Response to non-final office action dated Dec. 31, 2013 for U.S. Appl. No. 13/411,344, filed Mar. 31, 2014, 12 pages.
 Patent Owner's Response to Office Action dated Nov. 13, 2012 for Reexamination Control Nos. 95/000,578; 95/000,579, and 95/001,339, filed Jan. 14, 2013, 96 pages.
 Patent Owner's Response to Office Action dated Dec. 19, 2012 for Reexamination Control No. 95/001,758, filed Mar. 19, 2013, 61 pages.
 Patent Owner's Response to Office Action dated Sep. 26, 2013 for Reexamination Control No. 95/001,758, filed Nov. 26, 2013, 85 pages.
 Third Party Requester's Comments after Non-Final Action dated Sep. 26, 2013 for Reexamination Control No. 95/001,758, filed Dec. 26, 2013.
 Patent Owner's Appeal Brief for Reexamination Control Nos. 95/000,546 and 95/000,577, filed Oct. 2, 2013, 46 pages.
 Patent Trial and Appeal Board Decision on Appeal for Reexamination Control No. 95/001/337, mailed Jan. 16, 2014, 30 pages.
 Patent Trial and Appeal Board Decision on Appeal for Reexamination Control No. 95/001/381, mailed Jan. 16, 2014, 24 pages.
 Action Closing Prosecution mailed Mar. 27, 2014 for Reexamination Control No. 95/001,758, filed Sep. 14, 2011, 40 pages.

Action Closing Prosecution mailed Mar. 27, 2014 for Reexamination Control No. 95/001,339, filed Jun. 8, 2010, 106 pages.
 Notice of Allowance, U.S. Appl. No. 12/504,131, dated Feb. 12, 2013, 52 pgs.
 Response to Non-Final Office Action dated Jan. 2, 2014, filed Apr. 2, 2004, for U.S. Appl. No. 13/287,042, filed Nov. 1, 2011, 12 pages.
 Non-Final Action Closing Prosecution mailed Sep. 1, 2010, for Control No. 95/001,339, filed Apr. 10, 2010, 17 pages.
 Non-Final Action Closing Prosecution mailed Jun. 21, 2011, for Control No. 95/001,381, filed Jun. 9, 2010, 34 pages.
 Non-Final Action Closing Prosecution mailed Mar. 12, 2012, for Control No. 95/001,337, filed Apr. 19, 2010, 33 pages.
 Non-Final Action mailed Aug. 27, 2010, for Control No. 95/000,546, filed May 11, 2010, 16 pages.
 Non-Final Action mailed Sep. 8, 2010, for Control No. 95/001,381, filed Jun. 9, 2010, 17 pages.
 Non-Final Action mailed Apr. 4, 2011, for Control No. 95/001,339, filed Apr. 20, 2010, 61 pages. (merged with 95/000,578 and 95/000,579).
 Non-Final Action mailed Jun. 15, 2011, for Control No. 95/001,381, filed Jun. 9, 2010, 33 pages.
 Non-Final Action mailed Sep. 27, 2011, for Control No. 95/001,337, filed Apr. 19, 2010, 19 pages.
 Non-Final Action mailed Oct. 4, 2011, for Control No. 95/001,339, filed Apr. 20, 2010, 77 pages. (merged with 95/000,578 and 95/000,579).
 Non-Final Action mailed Oct. 14, 2011, for Control No. 95/001,339, filed Apr. 30, 2010, 99 pages. (merged with 95/000,578 and 95/000,579).
 Non-Final Office Action dated Nov. 16, 2011, for U.S. Appl. No. 95/001,758 filed Sep. 14, 2011, 25 pages.
 Reexam Appl. No. 95/000,546 for U.S. Pat. No. 7,289,386, filed May 11, 2010, Netlist, Inc., Entire File History.
 Reexam Appl. No. 95/000,577 for U.S. Pat. No. 7,289,386, filed Oct. 20, 2010, Netlist, Inc., Entire File History.
 Reexam Appl. No. 95/000,578 for U.S. Pat. No. 7,619,912, filed Oct. 20, 2010, Netlist, Inc., Entire File History.
 Reexam Appl. No. 95/000,579 for U.S. Pat. No. 7,619,912, filed Oct. 21, 2010, Netlist, Inc., Entire File History.
 Reexam App. No. 95/001,337 for U.S. Pat. No. 7,636,274, filed Jun. 4, 2010, Netlist, Inc., Entire File History.
 Reexam Appl. No. 95/001,381 for U.S. Pat. No. 7,532,537, filed Jun. 9, 2010, Netlist, Inc., Entire File History.
 Reexam Appl. No. 95/001,338; for U.S. Pat. No. 7,532,537, filed Apr. 19, 2010, Netlist, Inc., Entire File History.
 Reexam Appl. No. 95/001,758 for U.S. Pat. No. 7,864,627, filed Sep. 15, 2010, Netlist, Inc., Entire File History.
 Reexam Appl. No. 95/001,339 for U.S. Pat. No. 7,619,912, filed Jun. 8, 2010 Netlist, Inc., Entire File History.
 Reexam Appl. No. 95/002,399 for U.S. Pat. No. 8,250,295, filed Sep. 15, 2010, Netlist, Inc., Entire File History.
 U.S. Appl. No. 11/075,395, filed Mar. 7, 2005 Netlist Inc., Entire Prosecution History.
 U.S. Appl. No. 11/173,175, filed Jul. 1, 2005 Netlist, Inc., Entire Prosecution History.
 U.S. Appl. No. 11/862,931, filed Sep. 27, 2007 Netlist, Inc., Entire Prosecution History.
 U.S. Appl. No. 12/577,682, filed Oct. 12, 2009, Netlist, Inc., Entire Prosecution History.
 U.S. Appl. No. 12/954,492, filed Nov. 24, 2010, Netlist, Inc., Entire Prosecution History.
 U.S. Appl. No. 12/912,623, filed Oct. 26, 2010, Netlist, Inc., Entire Prosecution History.
 U.S. Appl. No. 11/335,875, filed Jan. 19, 2006, Netlist, Inc., Entire Prosecution History.
 U.S. Appl. No. 12/408,652, filed Mar. 20, 2009, Netlist, Inc., Entire Prosecution History.
 U.S. Appl. No. 12/629,827, filed Dec. 2, 2009, Netlist Inc., Entire Prosecution History.
 U.S. Appl. No. 12/955,711, filed Nov. 29, 2010, Netlist, Inc., Entire Prosecution History.
 U.S. Appl. No. 12/981,380, filed Dec. 29, 2010, Netlist Inc., Entire Prosecution History.
 U.S. Appl. No. 13/154,172, filed Jun. 6, 2011, Netlist, Inc., Entire Prosecution History.

(56)

References Cited

OTHER PUBLICATIONS

U.S. Appl. No. 13/287,042, filed Nov. 1, 2011, Netlist, Inc., Entire Prosecution History.

U.S. Appl. No. 13/473,413, filed May 16, 2012, Netlist, Inc., Entire Prosecution History.

U.S. Appl. No. 13/032,470, filed Feb. 22, 2011, Netlist Inc., Entire Prosecution History.

U.S. Appl. No. 13/288,081, filed Nov. 1, 2011, Netlist, Inc., Entire Prosecution History.

U.S. Appl. No. 13/971,231, filed Aug. 20, 2013, Netlist, Inc., Entire Prosecution History.

U.S. Appl. No. 12/422,853, filed Apr. 13, 2009, Netlist, Inc., Entire Prosecution History.

U.S. Appl. No. 13/412,243, filed Mar. 5, 2012, Netlist, Inc., Entire Prosecution History.

U.S. Appl. No. 12/422,925, filed Apr. 13, 2009, Netlist, Inc., Entire Prosecution History.

U.S. Appl. No. 13/183,253, filed Jul. 14, 2011, Netlist, Inc., Entire Prosecution History.

U.S. Appl. No. 13/745,790, filed Jan. 19, 2013, Netlist, Inc., Entire Prosecution History.

U.S. Appl. No. 14/229,844, filed Mar. 29, 2014, Netlist, Inc., Entire Prosecution History.

U.S. Appl. No. 12/504,131, filed Jul. 16, 2009, Netlist, Inc., Entire Prosecution History.

U.S. Appl. No. 12/761,179, filed Apr. 15, 2010, Netlist, Inc., Entire Prosecution History.

U.S. Appl. No. 13/288,850, filed Nov. 3, 2011, Netlist, Inc., Entire Prosecution History.

U.S. Appl. No. 13/411,344, filed Mar. 2, 2012, Netlist, Inc., Entire Prosecution History.

U.S. Appl. No. 13/952,599, filed Jul. 27, 2013, Netlist, Inc., Entire Prosecution History.

U.S. Appl. No. 13/411,344, filed Mar. 2, 2011, Lee, Entire Prosecution.

U.S. Appl. No. 13/970,606, filed Aug. 20, 20, Netlist, Entire Prosecution.

U.S. Appl. No. 13/971,231, filed Aug. 20, 20, Netlist, Entire Prosecution.

U.S. Appl. No. 14/229,844, Mar. 29, 20, Netlist, Entire Prosecution.

U.S. Appl. No. 14/324,990, filed Jul. 7, 2011, Netlist, Entire Prosecution.

U.S. Appl. No. 14/337,168, filed Jul. 21, 20, Netlist, Entire Prosecution.

International Search Report and Written Opinion, PCT/US2010/040826, Sep. 27.

Written Opinion of the International Preliminary Examining Authority, PCT/US2010/040826, dated Oct. 24, 2011.

International Preliminary Report on Patentability, PCT/US2010/040826, dated Nov. 28.

International Search Report and Written Opinion, PCT/US2011/059209, dated Jan. 30, 2013.

Notice of Allowance dated Feb. 12, 2013, for U.S. Appl. No. 12/504,131, filed Jul. 16, 2009, 52 pages.

Non-Final Office Action dated Sep. 13, 2012, for U.S. Appl. No. 12/761,179, filed Apr. 15, 2010, 20 pages.

Response to Non-Final Office Action dated Sep. 13, 2012, for U.S. Appl. No. 12/761,179, filed Mar. 13, 2013, 16 pages.

Notice of Allowance dated Jul. 11, 2013, for U.S. Appl. No. 12/761,179 filed Apr. 15, 2010, 37 pages.

Inter Partes Review Case No. IPR2014-01029, Petition for Inter Partes Review of U.S. Pat. No. 8,516,185, filed on Jun. 24, 2014.

Inter Partes Review Case No. IPR2014-01029, Exhibit 1008 to Petition for Inter Partes Review, "Declaration of Charles J. Neuhauser, Ph.D. under 37 C.F.R. § 1.68," filed on Jun.

Inter Partes Review Case No. IPR2014-01029, Patent Owner's Preliminary Response pursuant to 37 C.F.R. § 42.107, filed on Oct. 17, 2014.

Inter Partes Review Case No. IPR2014-01029, Decision Denying Institution of Inter Partes Review 37 C.F.R. § 42.108, issued Dec. 16, 2014.

Inter Partes Review Case No. IPR2014-01369, Corrected Petition for Inter Partes Review of Claims 1-19 of U.S. Pat. No. 8,516,185, filed on Sep. 22, 2014.

Inter Partes Review Case No. IPR2014-01369, Exhibit 1008 to Corrected Petition for Inter Partes Review, "Declaration of Dr. Nader Bagherzadeh under 37 C.F.R. § 1.68," filed on Sep. 22, 2014.

Inter Partes Review Case No. IPR2014-01369, Exhibit 1013 to Corrected Petition for Inter Partes Review, "Webster's II New College Dictionary," filed on Sep. 22, 2014.

Inter Partes Review Case No. IPR2014-01369, Exhibit 1014 to Corrected Petition for Inter Partes Review, "Standard Dictionary of Electrical and Electronics Terms," IEEE 1988, filed on Sep. 22, 2014.

Inter Partes Review of U.S. Pat. No. 7,881,150, IPR Case No. IPR2014-00882, Corrected Petition for Inter Partes Review of U.S. Pat. No. 7,881,150, filed on Jul. 8.

Inter Partes Review of U.S. Pat. No. 7,881,150, IPR Case No. IPR2014-00882, Exhibit 1007 to Petition for Inter Partes Review, "Declaration of Dr. Srinivasan Jagannathan," filed on Jun. 22, 2014.

Inter Partes Review of U.S. Pat. No. 7,881,150, IPR Case No. IPR2014-00882, Patent Owner's Preliminary Response Pursuant to 37 C.F.R. § 42.107, filed Oct. 7, 2014.

Inter Partes Review of U.S. Pat. No. 7,881,150, IPR Case No. IPR2014-00882, Decision—Institution of Inter Partes Review 37 C.F.R. § 42.108, issued Dec. 16.

Inter Partes Review of U.S. Pat. No. 8,081,536, IPR Case No. IPR2014-00883, Corrected Petition for Inter Partes Review of U.S. Pat. No. 8,081,536, filed on Jul. 8.

Inter Partes Review of U.S. Pat. No. 8,081,536, IPR Case No. IPR2014-00883, Exhibit 1011 to Petition for Inter Partes Review, "Declaration of Dr. Srinivasan Jagannathan," filed on Jun. 21, 2014.

Inter Partes Review of U.S. Pat. No. 8,081,536, IPR Case No. IPR2014-00883, Patent Owner's Preliminary Response Pursuant to 37 C.F.R. § 42.107, filed Oct. 7, 2014.

Inter Partes Review of U.S. Pat. No. 8,081,536, IPR Case No. IPR2014-00883, Decision—Institution of Inter Partes Review 37 C.F.R. § 42.108, issued Dec. 16.

Inter Partes Review of U.S. Pat. No. 7,881,150, IPR Case No. IPR2014-01011, Corrected Petition for Inter Partes Review of U.S. Pat. No. 7,881,150, filed on Jul. 8.

Inter Partes Review of U.S. Pat. No. 7,881,150, IPR Case No. IPR2014-01011, Exhibit 1007 to Petition for Inter Partes Review, "Declaration of Dr. Srinivasan Jagannathan," filed on Jun. 22, 2014.

Inter Partes Review of U.S. Pat. No. 7,881,150, IPR Case No. IPR2014-01011, Patent Owner's Preliminary Response Pursuant to 37 C.F.R. § 42.107, filed Oct. 7, 2014.

Inter Partes Review of U.S. Pat. No. 7,881,150, IPR Case No. IPR2014-01011, Decision—Institution of Inter Partes Review 37 C.F.R. § 42.108, issued Dec. 16.

Inter Partes Review of U.S. Pat. No. 7,881,150, IPR Case No. IPR2014-01011, Exhibit 3001 to Decision—Institution of Inter Partes Review, Excerpts from IEEE Dictionary, issued Dec. 16, 2014.

Inter Partes Review of U.S. Pat. No. 7,881,150, IPR Case No. IPR2014-01011, Exhibit 3002 to Decision—Institution of Inter Partes Review, Excerpts from IEEE Dictionary, issued Dec. 16, 2014.

Inter Partes Review of U.S. Pat. No. 7,881,150, IPR Case No. IPR2014-01011, Exhibit 3003 to Decision—Institution of Inter Partes Review, Excerpts from Oxford English Dictionary, issued Dec. 16, 2014.

Inter Partes Review of U.S. Pat. No. 7,881,150, IPR Case No. IPR2014-01011, Exhibit 3004 to Decision—Institution of Inter Partes Review, Excerpts from Oxford English Dictionary, issued Dec. 16, 2014.

McCluskey, Edward J., Logic Design Principles with Emphasis on Testable Semicustom Circuits, Prentice Hall, 1986, pp. 104-107 and 119-120.

U.S. District Court Northern District of California, Case No. 4:13-CV-05889-YGR, *Netlist, Inc. v. Smart Storage Systems, Inc.*,

(56)

References Cited

OTHER PUBLICATIONS

- and *Diablo Technologies, Inc.*, Smart Storage Systems, Inc.'s Invalidity Contentions, dated Jun. 6, 2014.
- U.S. District Court Northern District of California, Case No. 4:13-CV-05889-YGR, *Netlist, Inc. v. Smart Storage Systems, Inc., and Diablo Technologies, Inc.*, Exhibits E.1-E.7 to "Smart Storage Systems, Inc.'s Invalidity Contentions," dated Jun. 6, 2014.
- U.S. District Court Northern District of California, Case No. 4:13-CV-05889-YGR, *Netlist, Inc. v. Smart Storage Systems, Inc., and Diablo Technologies, Inc.*, Exhibits F.1-F.5 to "Smart Storage Systems, Inc.'s Invalidity Contentions," dated Jun. 6, 2014.
- U.S. District Court Northern District of California, Case No. 4:13-CV-05889-YGR, *Netlist, Inc. v. Smart Storage Systems, Inc., and Diablo Technologies, Inc.*, Exhibits G.1-G.6 to "Smart Storage Systems, Inc.'s Invalidity Contentions," dated Jun. 6, 2014.
- U.S. District Court Northern District of California, Case No. 4:13-CV-05889-YGR, *Netlist, Inc. v. Smart Storage Systems, Inc., and Diablo Technologies, Inc.*, Exhibit H to "Smart Storage Systems, Inc.'s Invalidity Contentions," dated Jun. 6, 2014.
- U.S. District Court Northern District of California, Case No. 4:13-CV-05889-YGR, *Netlist, Inc. v. Smart Storage Systems, Inc., and Diablo Technologies, Inc.*, Diablo Technologies, Inc.'s Invalidity Contentions, dated Jun. 6, 2014.
- U.S. District Court Northern District of California, Case No. 4:13-CV-05889-YGR, *Netlist, Inc. v. Smart Storage Systems, Inc., and Diablo Technologies, Inc.*, Exhibits D-1 to D6 to "Diablo Technologies, Inc.'s Invalidity Contentions," dated Jun. 6, 2014.
- U.S. District Court Northern District of California, Case No. 4:13-CV-05889-YGR, *Netlist, Inc. v. Smart Storage Systems, Inc., and Diablo Technologies, Inc.*, Exhibits F-1 to F-5 to "Diablo Technologies, Inc.'s Invalidity Contentions," dated Jun. 6, 2014.
- U.S. District Court Northern District of California, Case No. 4:13-CV-05889-YGR, *Netlist, Inc. v. Smart Storage Systems, Inc., and Diablo Technologies, Inc.*, Exhibits G-1 to G-6 to "Diablo Technologies, Inc.'s Invalidity Contentions," dated Jun. 6, 2014.
- U.S. District Court Northern District of California, Case No. 4:13-CV-05889-YGR, *Netlist, Inc. v. Smart Storage Systems, Inc., and Diablo Technologies, Inc.*, Exhibit H to "Diablo Technologies, Inc.'s Invalidity Contentions," dated Jun. 6, 2014.
- Altera, ACEX iK, Programmable Logic Device Family, Data Sheet, May 2003, Ver 3.4.
- Horowitz, "The Art of Electronics," Cambridge Univ. Press, 1989, selected pages.
- Huang et al, "An Efficient Parallel Transparent BIST Method for Multiple Embedded Memory Buffers," VLSI Design 2011, p. 379.
- Jacob, Bruce L.; "Synchronous DRAM Architectures, Organizations, and Alternative Technologies". University of Maryland, Dec. 10, 2002.
- JEDEC Standard No. 21-C Section 4.5.7, 168 Pin Registered SDRAM DIMM Family, Release 7, Oct., 2001.
- JEDEC 21-C, Section 4.6.1, 278 Pin Buffered SDRAM DIMM Family, Jun. 1997.
- JEDEC Standard No. 21-C Section 4.1.2.5, Appendix E, "Specific PD's for Synchronous DRAM (SDRAM)," pp. 1-25, May 2003.
- JEDEC Standard, "Fully Buffered DIMM (FBDIMM): DFX Design for Validation and Test," JESD82- 28, Feb. 2008.
- Anonymous. (Dec. 1996). "Applications Note: Understanding DRAM Operation," IBM, 10 pages.
- Behrens, S. "HP Printer Memory Explained", The ZonkPage, Last Updated Jan. 21, 2004. Accessed Feb. 10, 2013, Retrieved from the Internet: URL.
- Non-final office action, U.S. Appl. No. 13/411,344, Jul. 7, 2014, 19 pages.
- Non-Final Office Action, U.S. Appl. No. 13/412,243, Jan. 2, 2014, 20 pages.
- Non-final office action, U.S. Appl. No. 13/288,850, Oct. 11, 2013, 24 pages.
- Non-final office action, U.S. Appl. No. 13/411,344, Dec. 31, 2013, 28.
- Non-final office action, U.S. Appl. No. 13/473,413, Nov. 17, 2011, 46.
- Response to non-final office action dated Oct. 11, 2013 for U.S. Appl. No. 13/288,850, filed Jan. 13, 2014, 15 pages.
- Notice of Allowance, U.S. Appl. No. 12/504,131, dated Feb. 12, 2013, 52 pages.
- Non-Final Office Action, dated Jan. 2, 2014, for U.S. Appl. No. 13/287,042, filed Nov. 1, 2011, 42 pages.
- Office Action dated Apr. 2, 2014, for Japanese Patent Application No. 2012-520662 and English translation thereof 7 pages.
- Miles J. Murdocca et al., "Principles of Computer Architecture", Prentice Hall, 2000, pp. 249-251.
- Intel® 6400/6402 Advanced Memory Buffer Datasheet, published Oct. 2006.
- Micron "Synchronous DRAM Module MT18LSDT472," 1998, Micron Technology, Inc., 17 pages.
- PC133 SDRAM Registered DIMM Design Specification, Revision 1.1, Aug. 1999, 62 pages.
- Micron DOR SDRAM DIMM Module 256MB. 512 MB. Mar. 2002. 26 pages.
- Reese, "Introduction to LogicSynthesis using Verilog HDL," Morgan & Claypool Publishers, 2006. pp. 1-28.
- 64 & 72 Pin Zip/Simm Sram Module, JEDEC, Standard No. 21-C, www.jedec.com/download/search/4 sub --04 sub --01.pdf Jun. 1997 pp.
- Distributed Memory Mapping. IP.com. IPCOM000014788D. 2000.
- Intel Corporation, 66/100 MHz PC SDRAM 64-Bit Non-ECC/Parity 144 Pin Unbuffered SO-DIMM Specification. Revision 1.0. Feb. 1999.
- Intel Corporation, PC SDRAM Registered DIMM Design Support Document, Revision 1.2, Oct. 1998.
- JEDEC "JEDEC Standard: Double Data Rate (DOR) SDRAM Specification", JESD79C Mar. 2003.
- JEDEC Standard No. 21-C, 4.20-2-168 Pin, PC133 SDRAM Registered Design Specification, Revision 1.4, Release 1.4, Feb. 2002.
- JEDEC Standard No. 21-C, DOR SDRAM PC2100 and PC1600 DOR SDRAM Registered DIMM Design Specification. Revision 1.3 Release 1b. Jan. 2002.
- Jedec Standard, "Definition of the SSTV16859 2.5 V 13-Bit to 26-Bit SSTL.sub.--2 Registered Buffer for Stacked DOR DIMM Applications," JFSD82-4B May 2003.
- Jin et al. "Embedded Memory in System-On-Chip Design: Architecture and Prototype Implementation." CCECE. 2003. pp. 141-146.
- Jin et al. "Prototype Implementation and Evaluation of a Multibank Embedded Memory Architecture in Programmable Logic," IEEE, 2003, pp. 13-16.
- Lee et al. "A banked-promotion translation lookaside buffer system," Journal of Systems Architecture. vol. 47. 2002. pp. 1065-1078.
- Lee et al. "An on-chip cache compression technique to reduce decompression overhead and design complexity," Journal of Systems Architecture, vol. 46, 2000, pp. 1365-1382.
- Micron "DOR SDRAM RDIMM, MT36VD0F12872-1GB, MT36V0DF25672-2GB," 2002 Micron Technology, Inc. 20 pages.
- Sunaga et al. "Continuous RAS Access Method in Multiple-bank DRAM Chip," IP.com, IPCOM000123375D, 1998.
- Takai et al. "250 Mbyte/s Synchronous DRAM Using a 3-Stage-Pipelined Architecture," IEEE Journal of Solid-State Circuits, vol. 29, No. 4, p. 426-431, dated Apr. 1994.
- Toal et al. "A 32-Bit SoPC Implementation of a PS." Proceedings of the Eighth IEEE International Symposium on Computers and Communications, 2003, pp. 1530-1546.
- Tudruj, Marek. "Dynamically reconfigurable heterogenous multi-processor systems with transputer-controlled communication," Journal of Systems Architecture, vol. 43, 1997, pp. 27-32.
- JEDEC Standard JESD79D, "Double Data Rate (DOR) SDRAM Specification," published Jan. 2004 (Feb. 2004).
- PC2100 and PC1600 DOR SDRAM Registered DIMM Design Specification JEDEC, Standard No. 21-C, Revision 1.3, Jan. 2002, pp. 4.20.4-1.
- Notice of Allowance, U.S. Appl. No. 13/970,606, filed Aug. 20, 2013, dated Jun. 27, 2016.

(56)

References Cited

OTHER PUBLICATIONS

Non-Final Office Action, U.S. Appl. No. 13/970,606, filed Aug. 20, 2013, dated Nov. 23, 2015.

Response to Non-Final Office Action, U.S. Appl. No. 13/970,606, filed Aug. 20, 2013, dated Mar. 23, 2016.

* cited by examiner

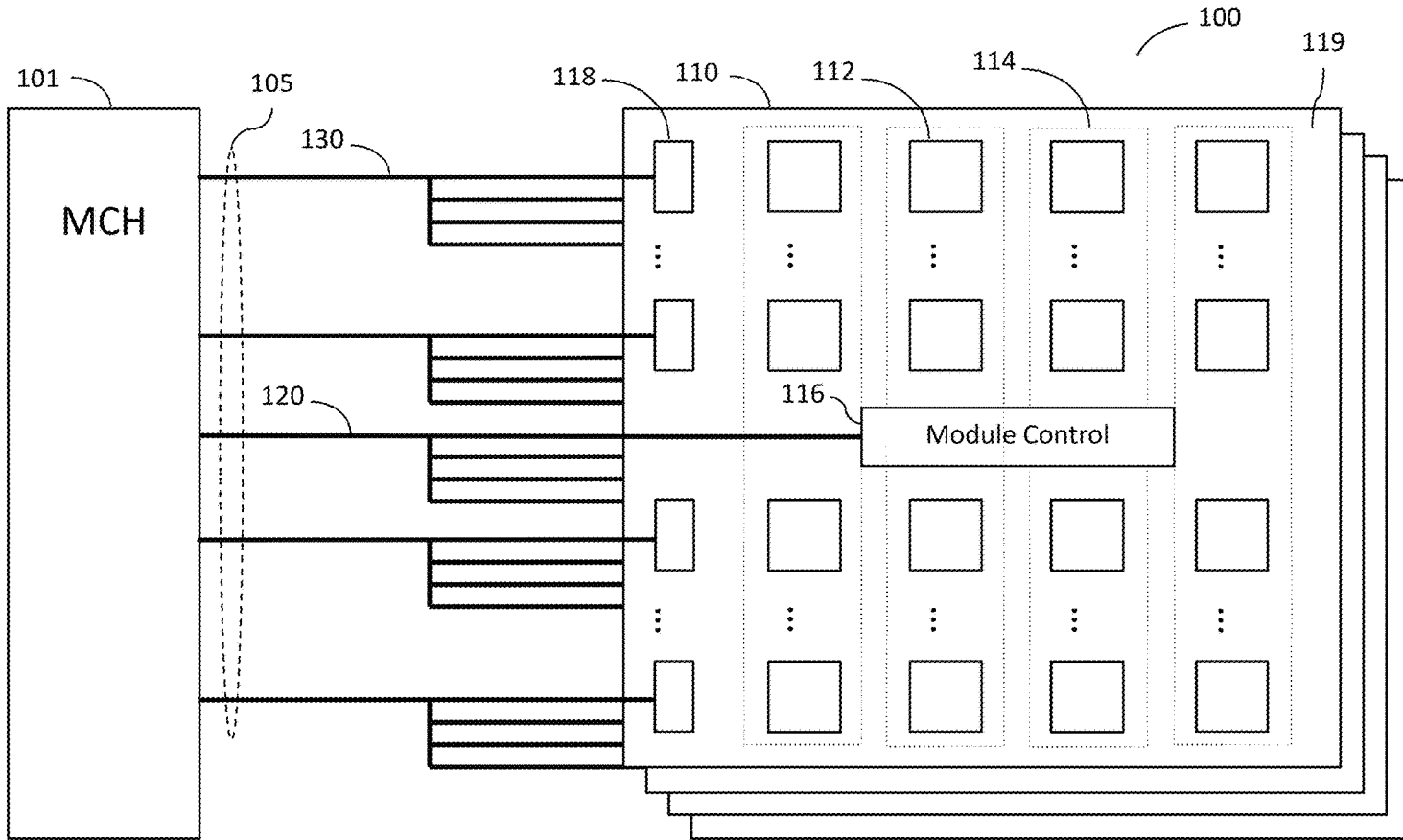

FIG. 1

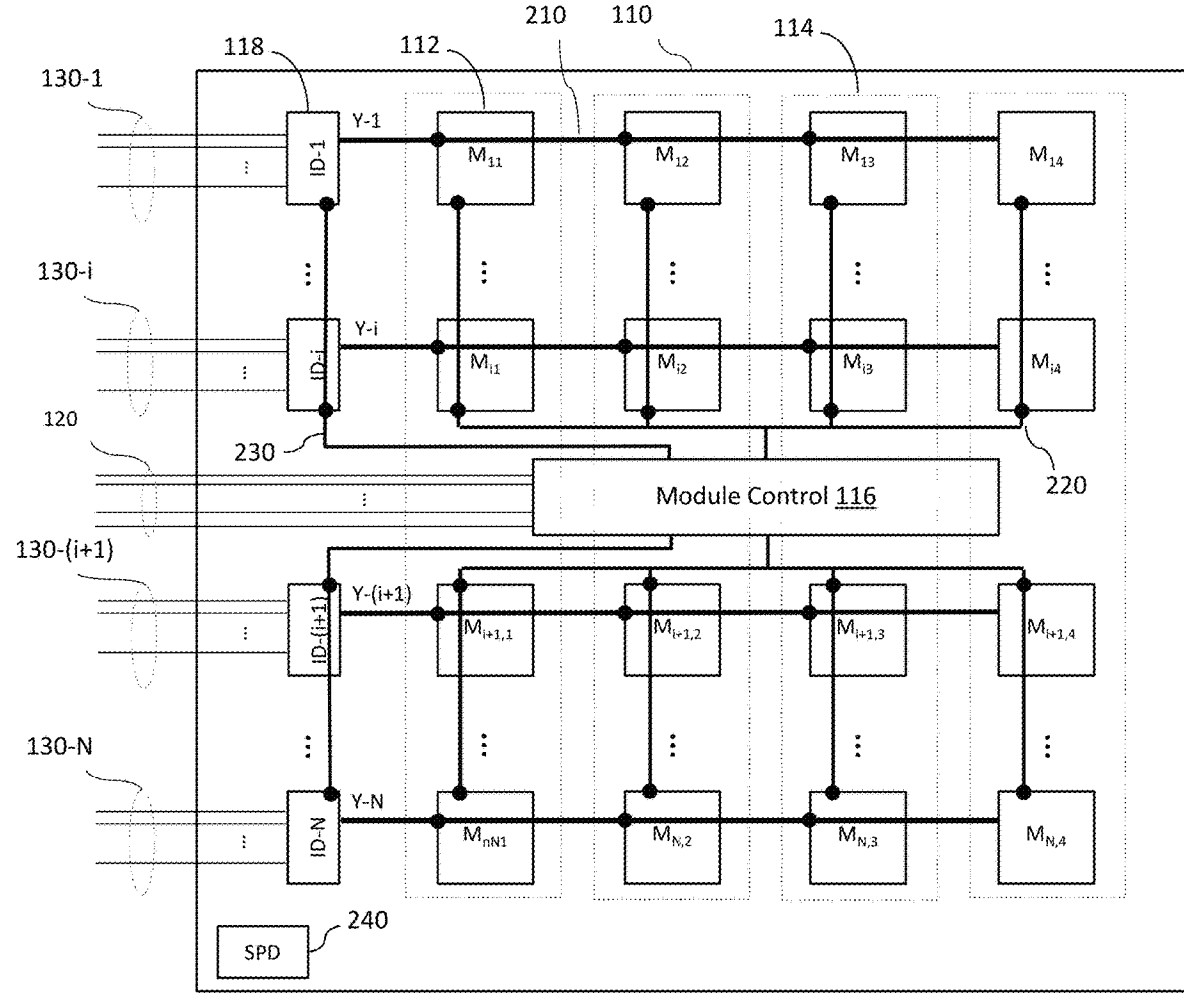

FIG. 2A

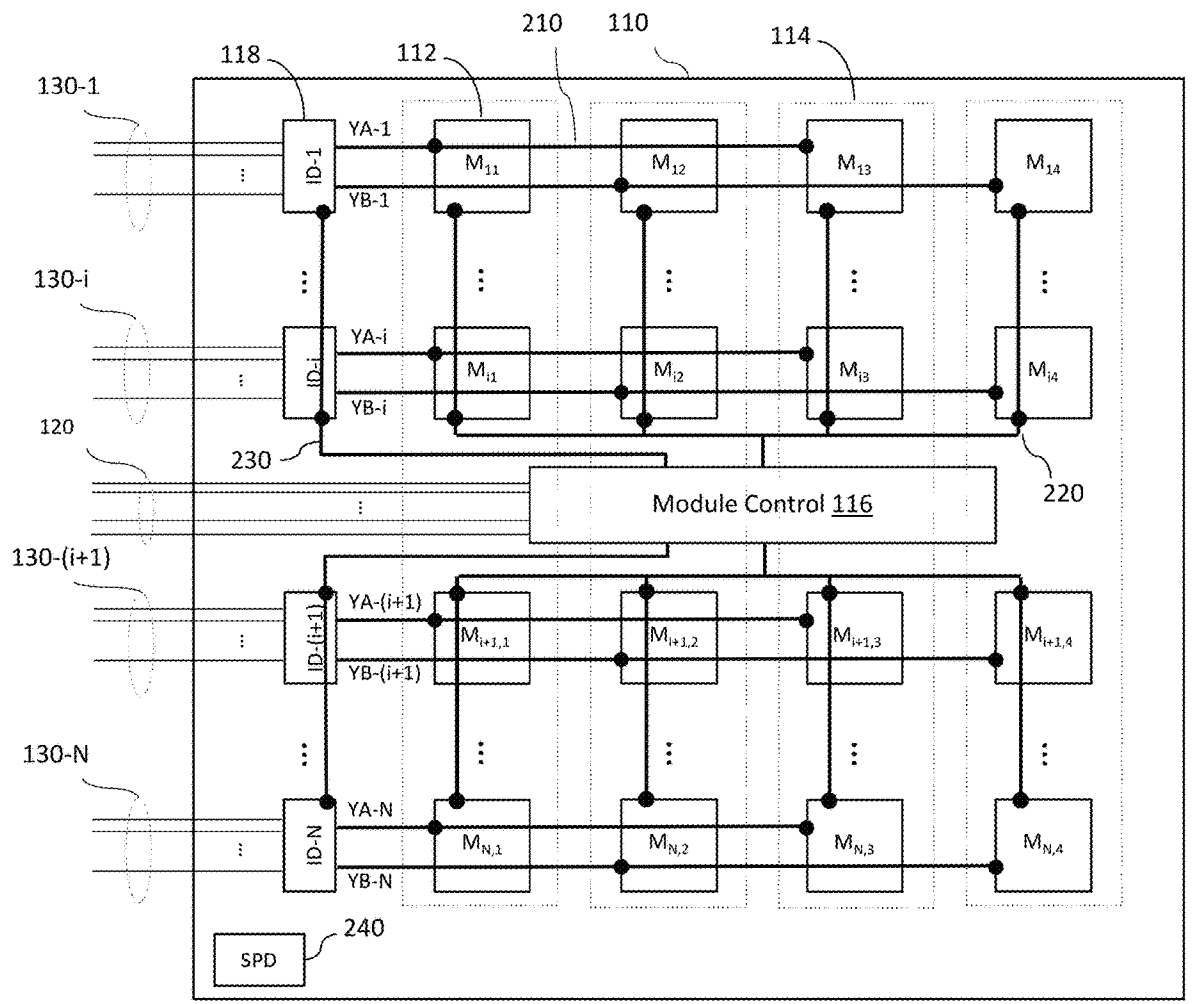

FIG. 2B

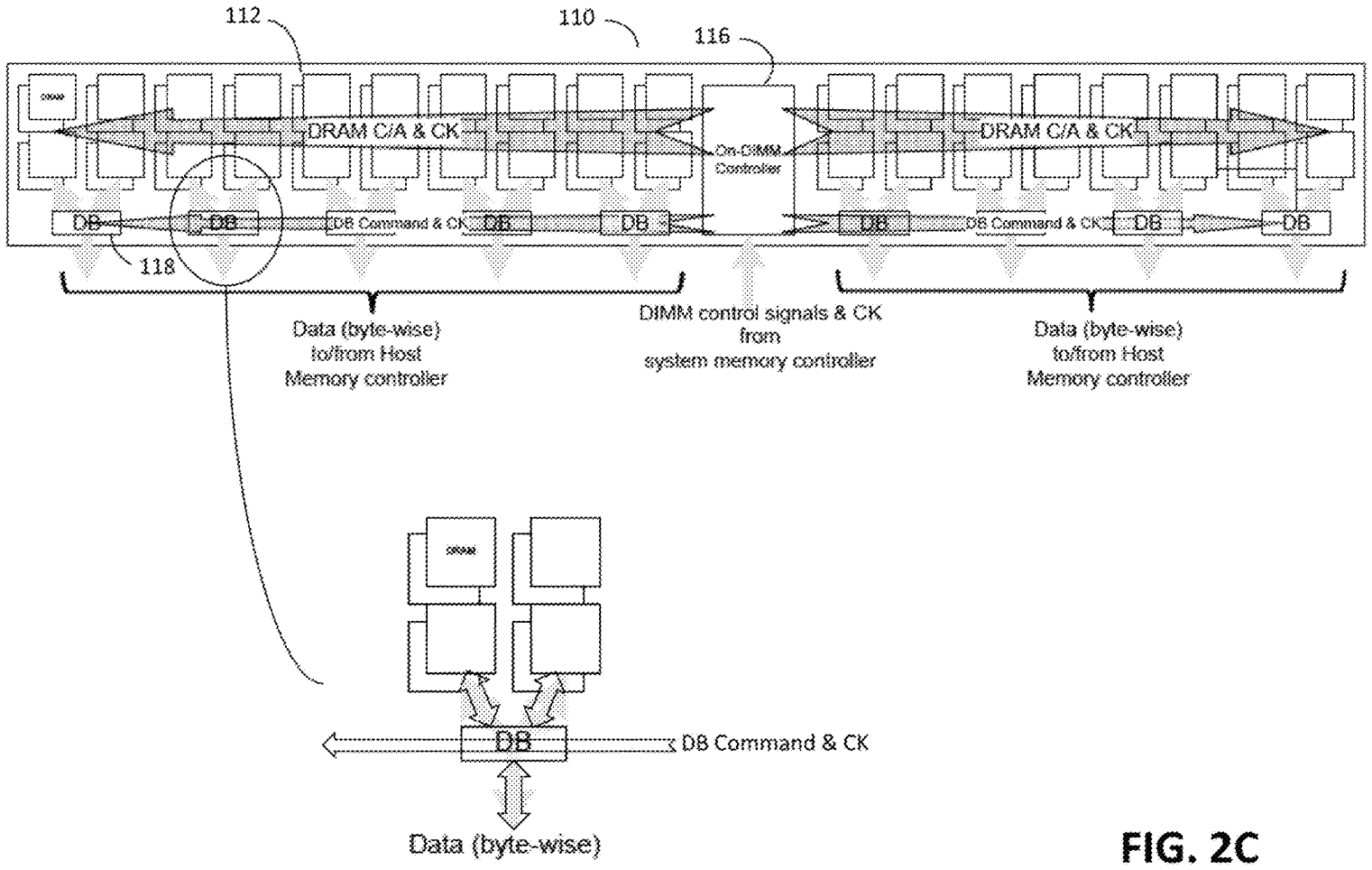

FIG. 2C

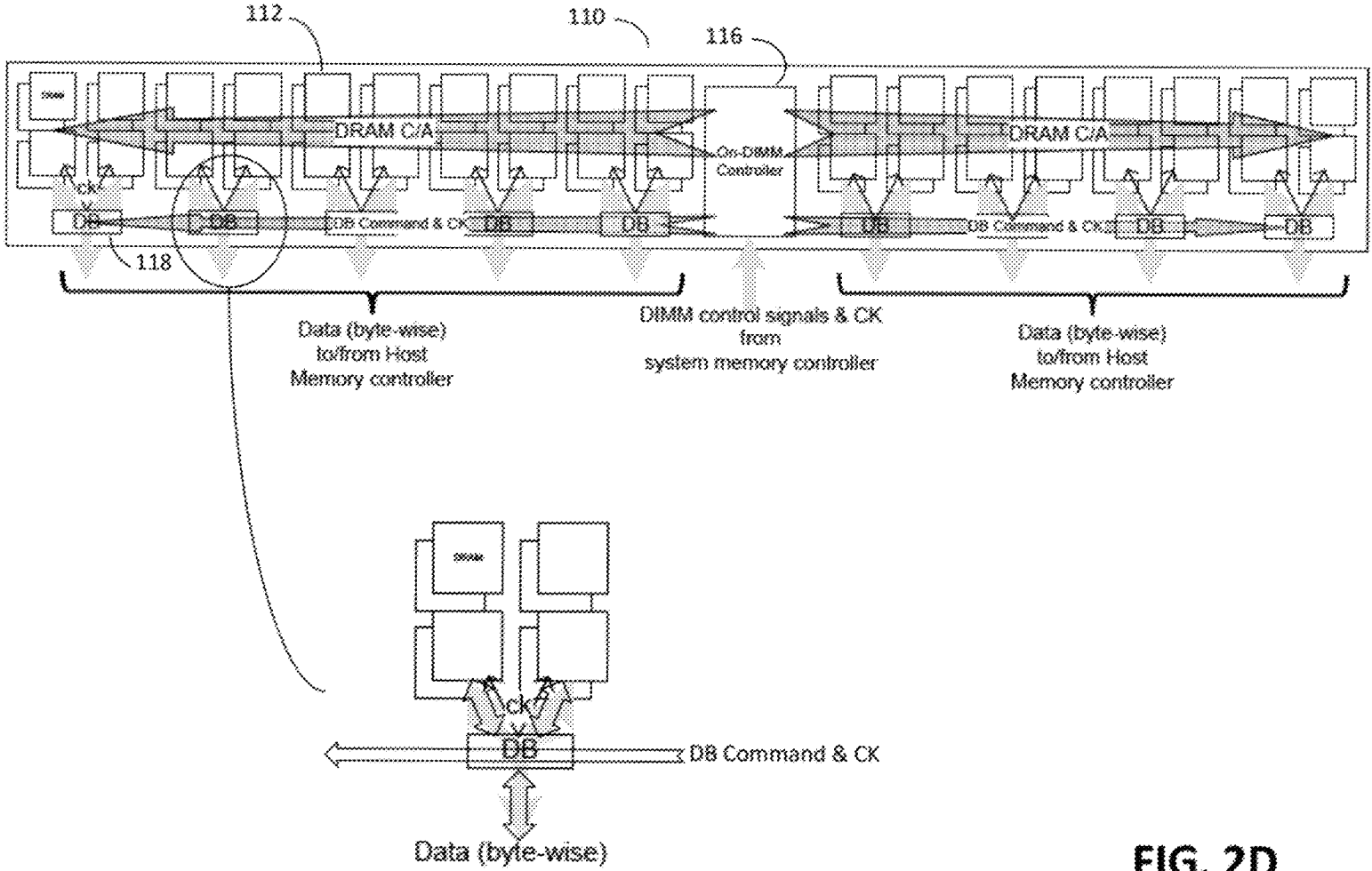

FIG. 2D

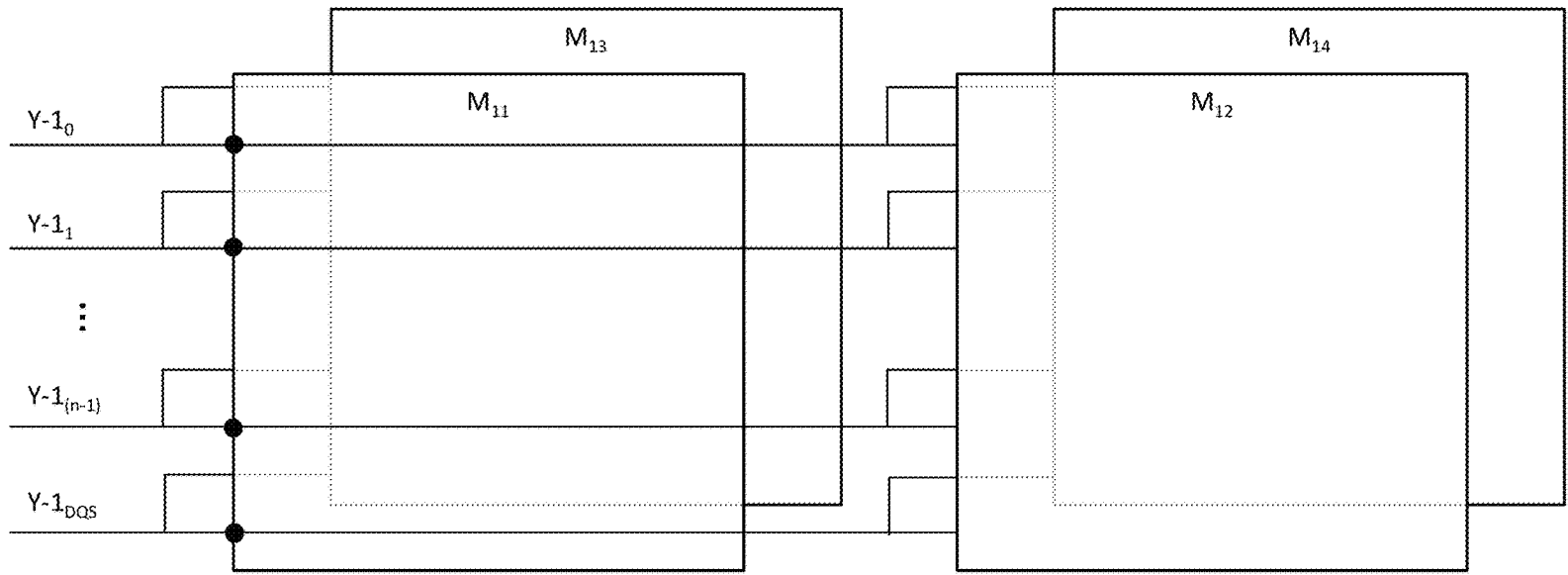

FIG. 4A

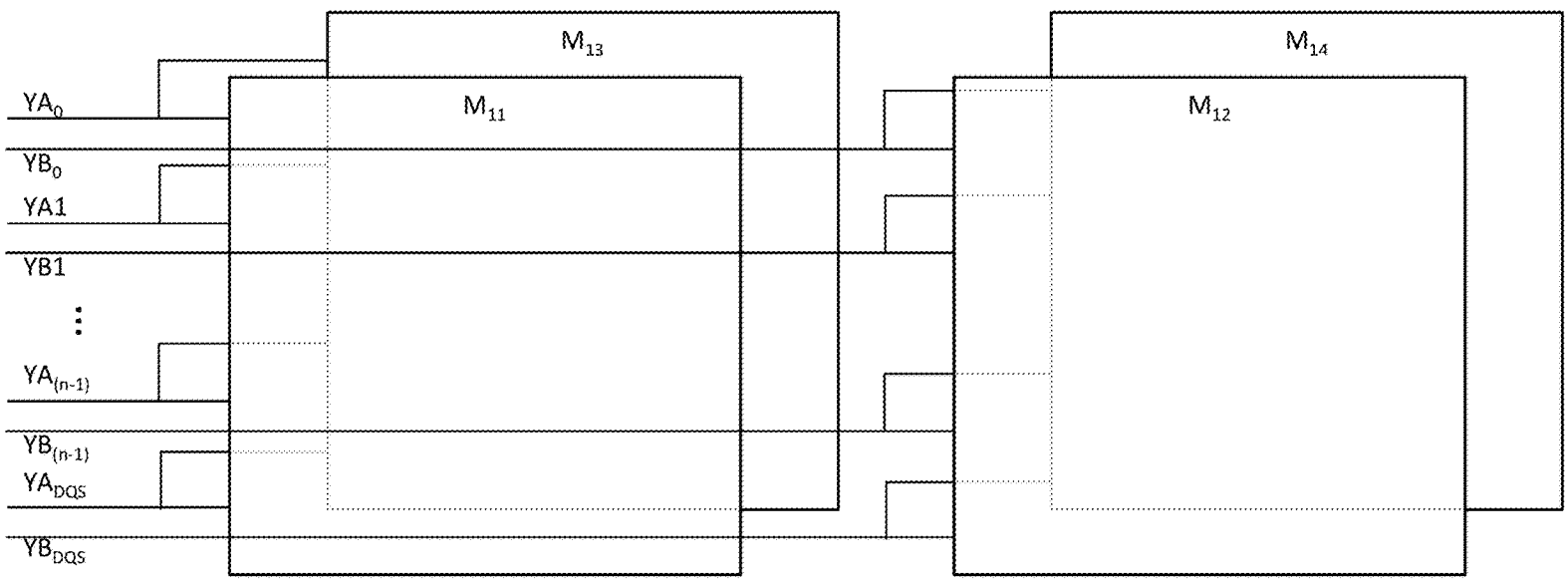

FIG. 4B

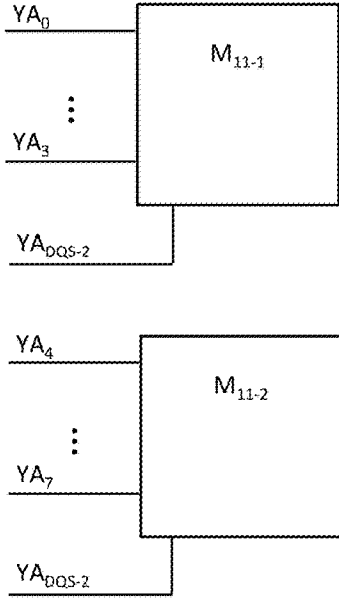

FIG. 5A

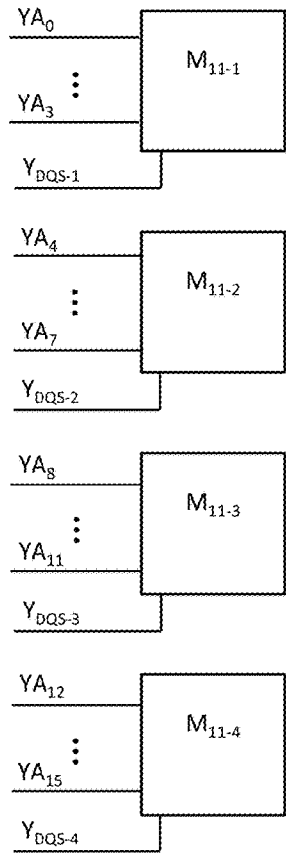

FIG. 5B

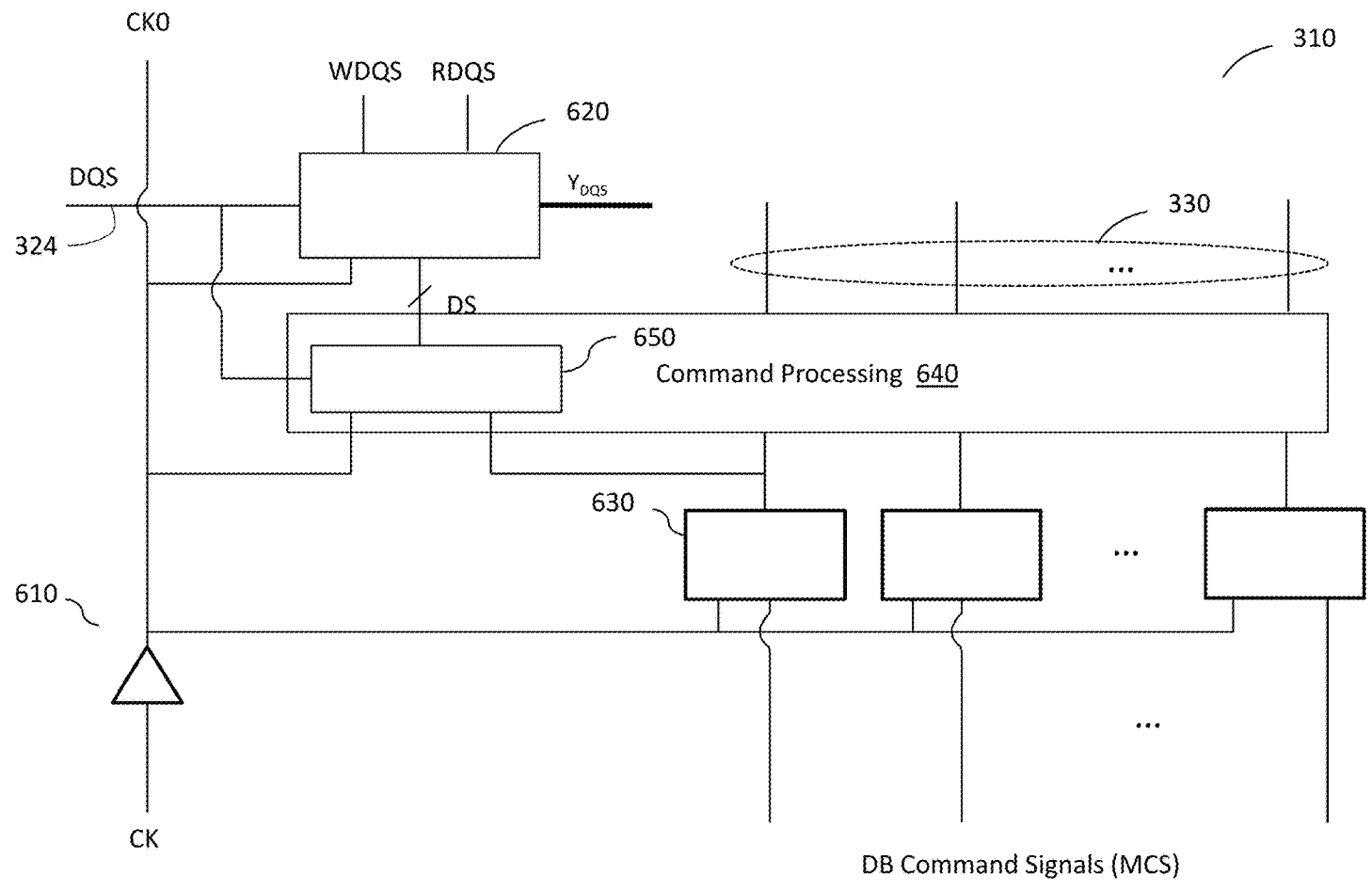

FIG. 6

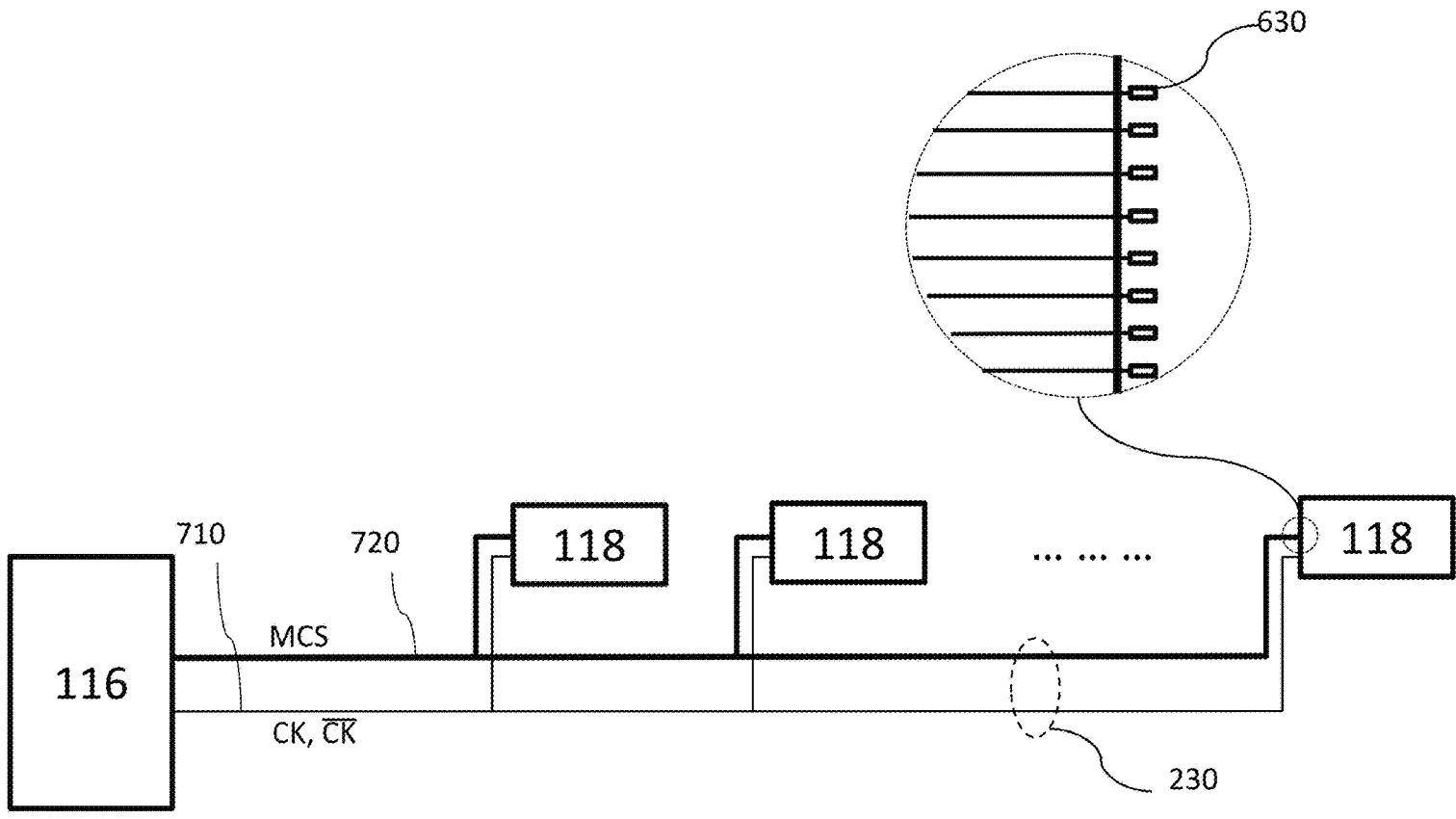

FIG. 7

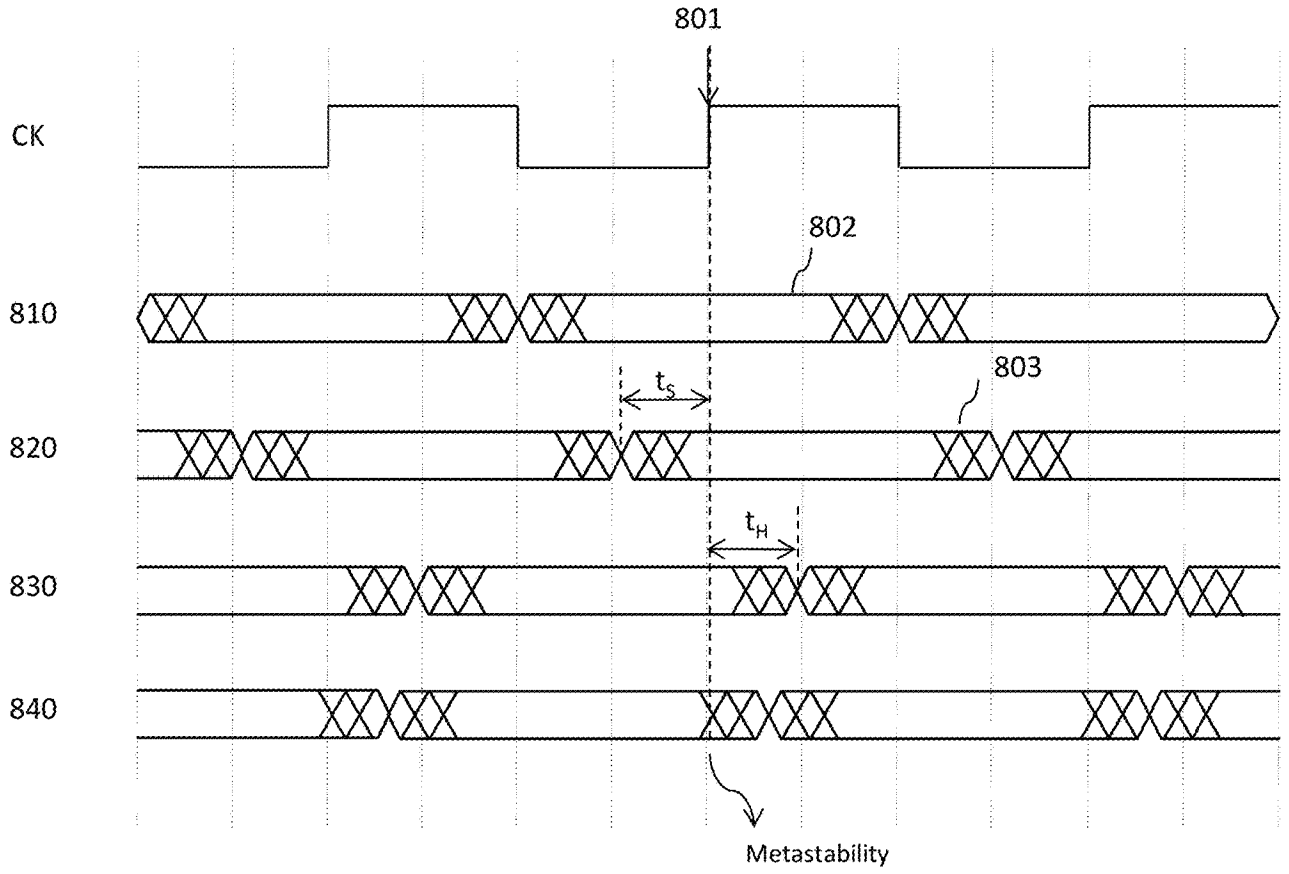

FIG. 8

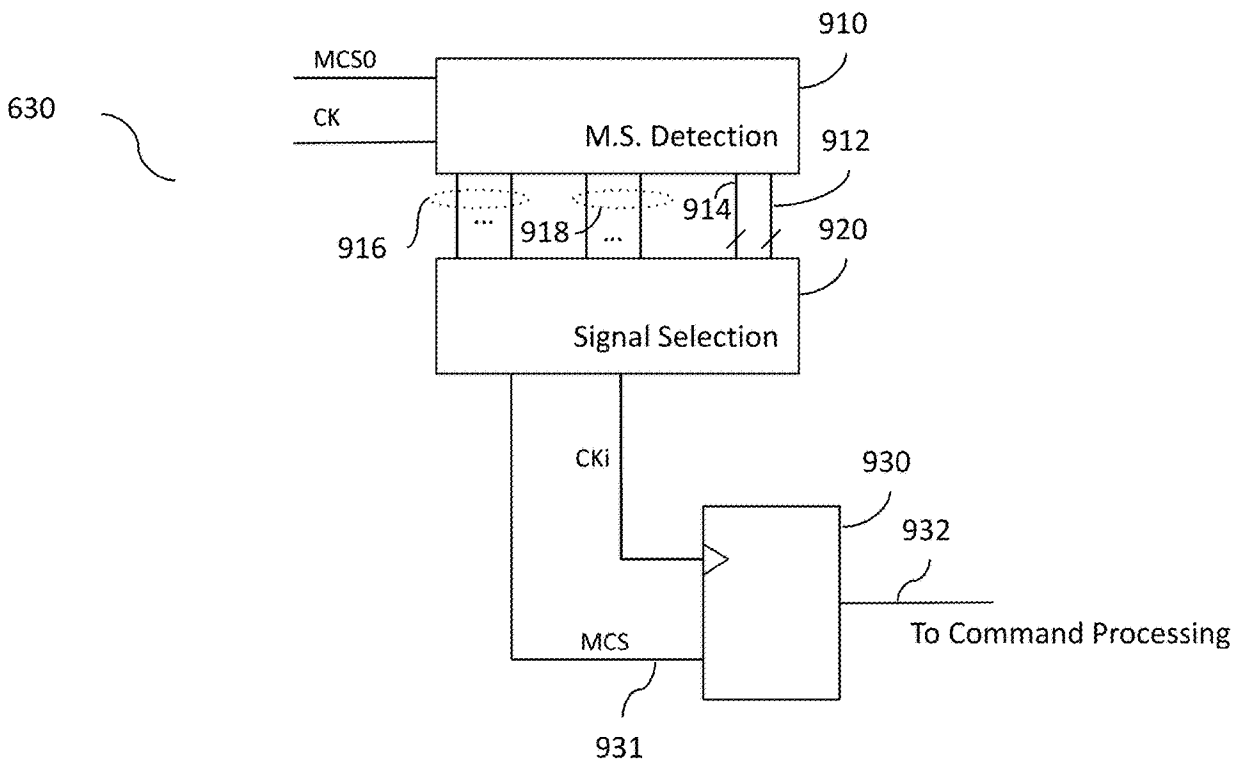

FIG. 9

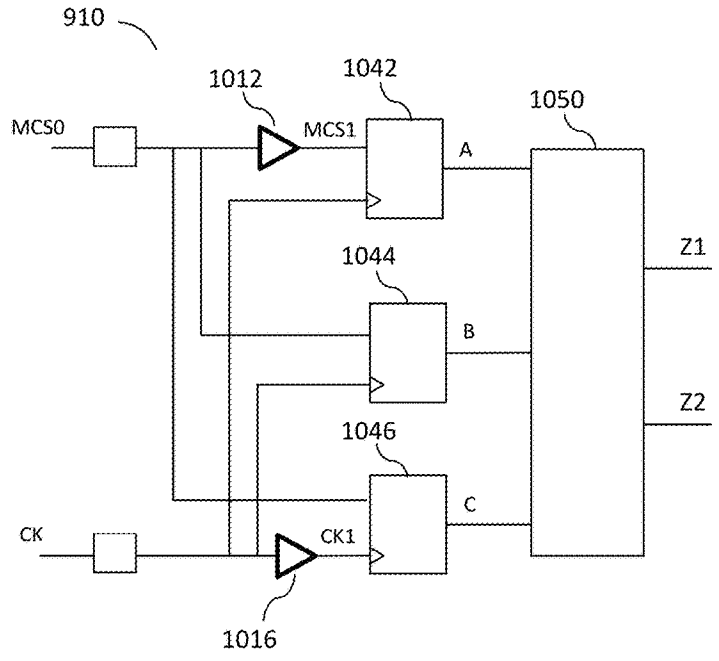

FIG. 10A

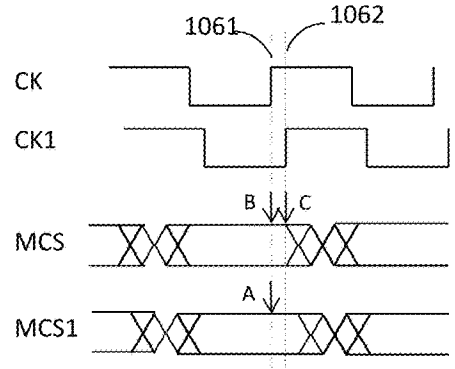

FIG. 10B

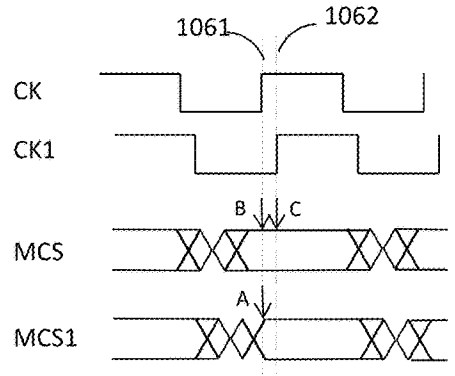

FIG. 10C

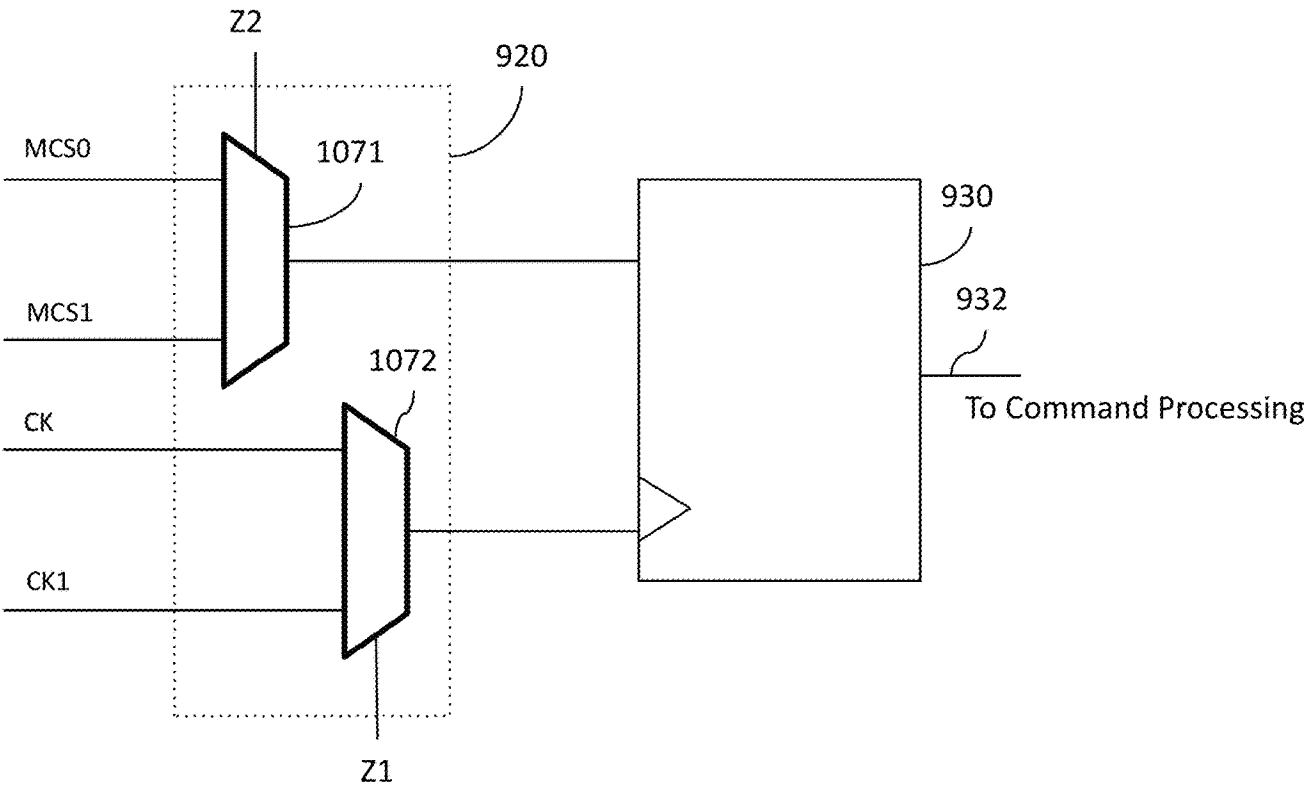

FIG. 10D

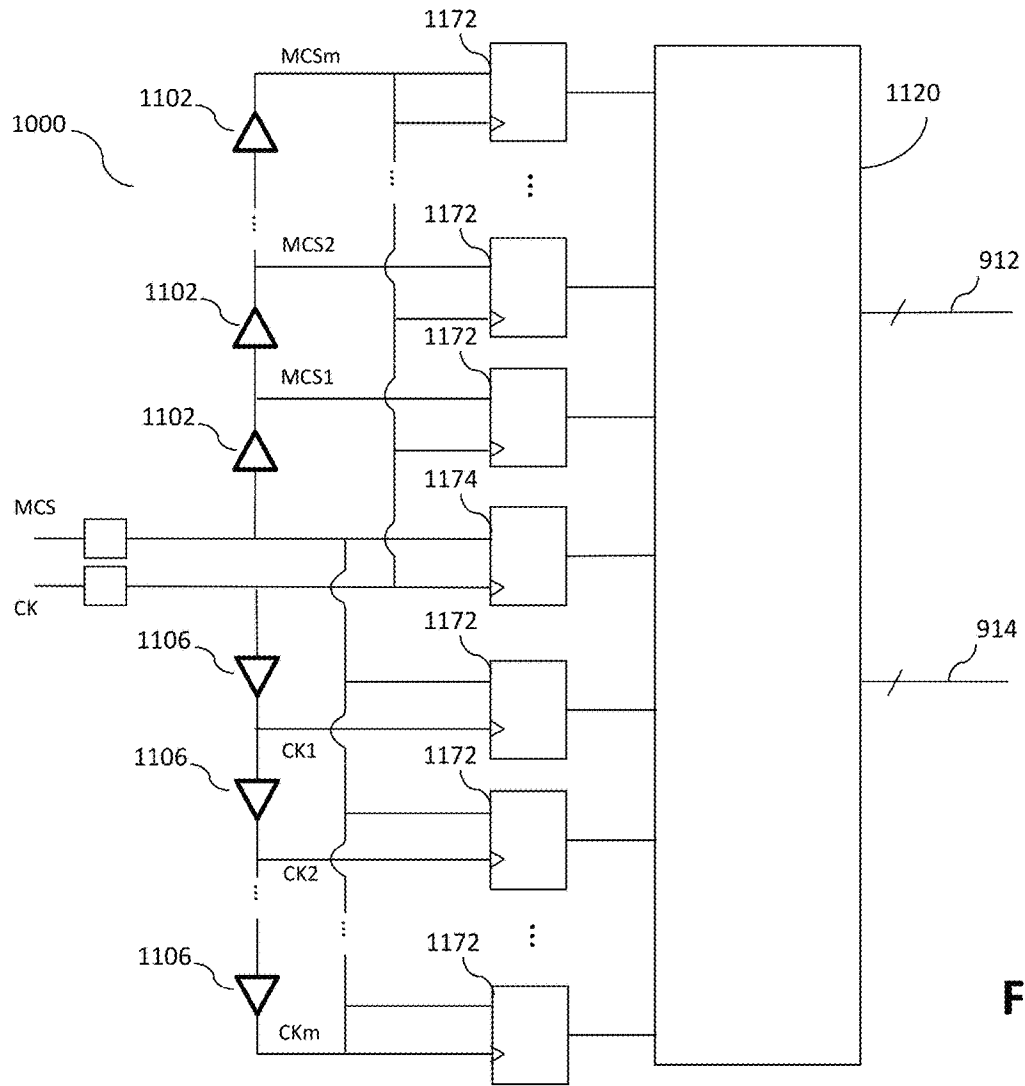

FIG. 11A

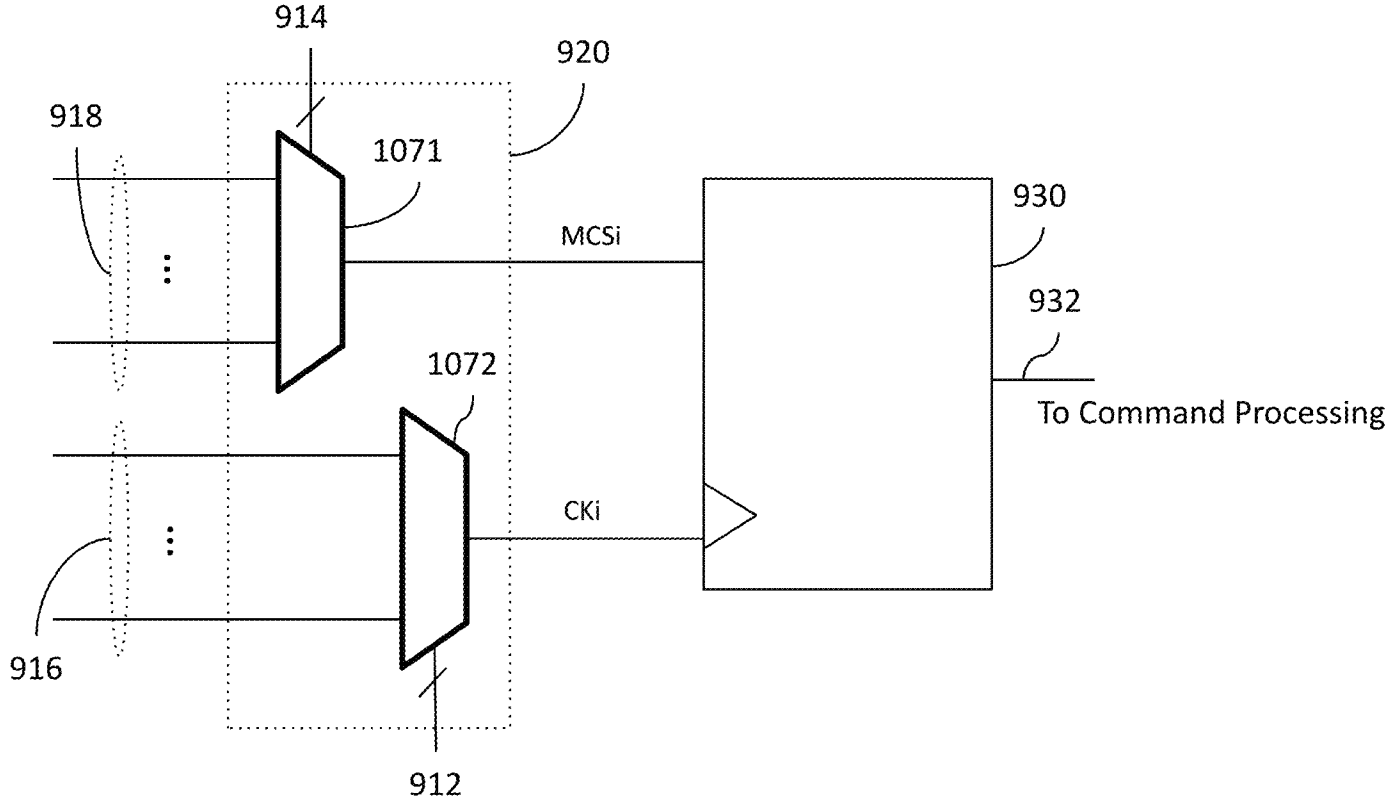

FIG. 11B

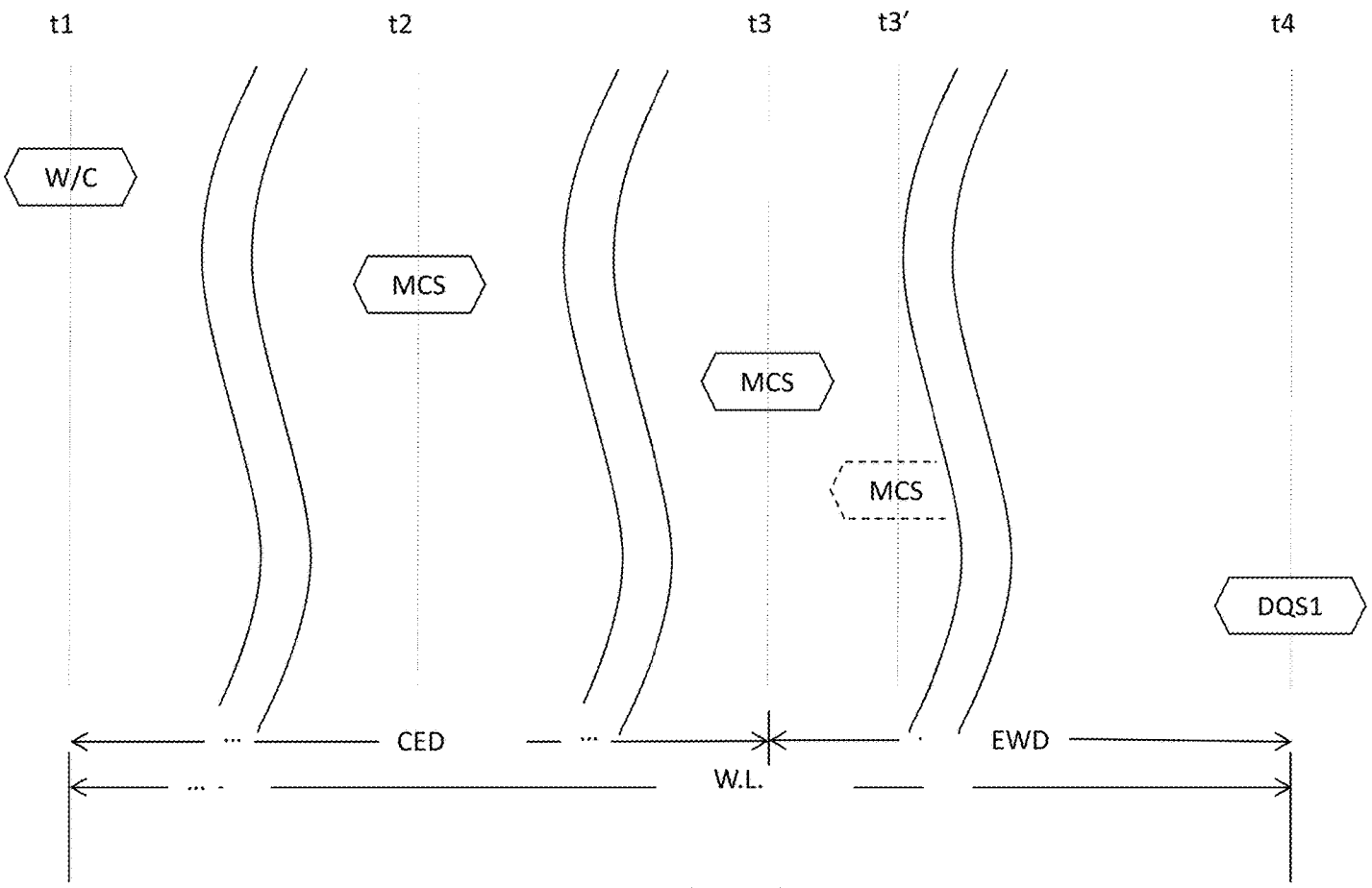

FIG. 12A

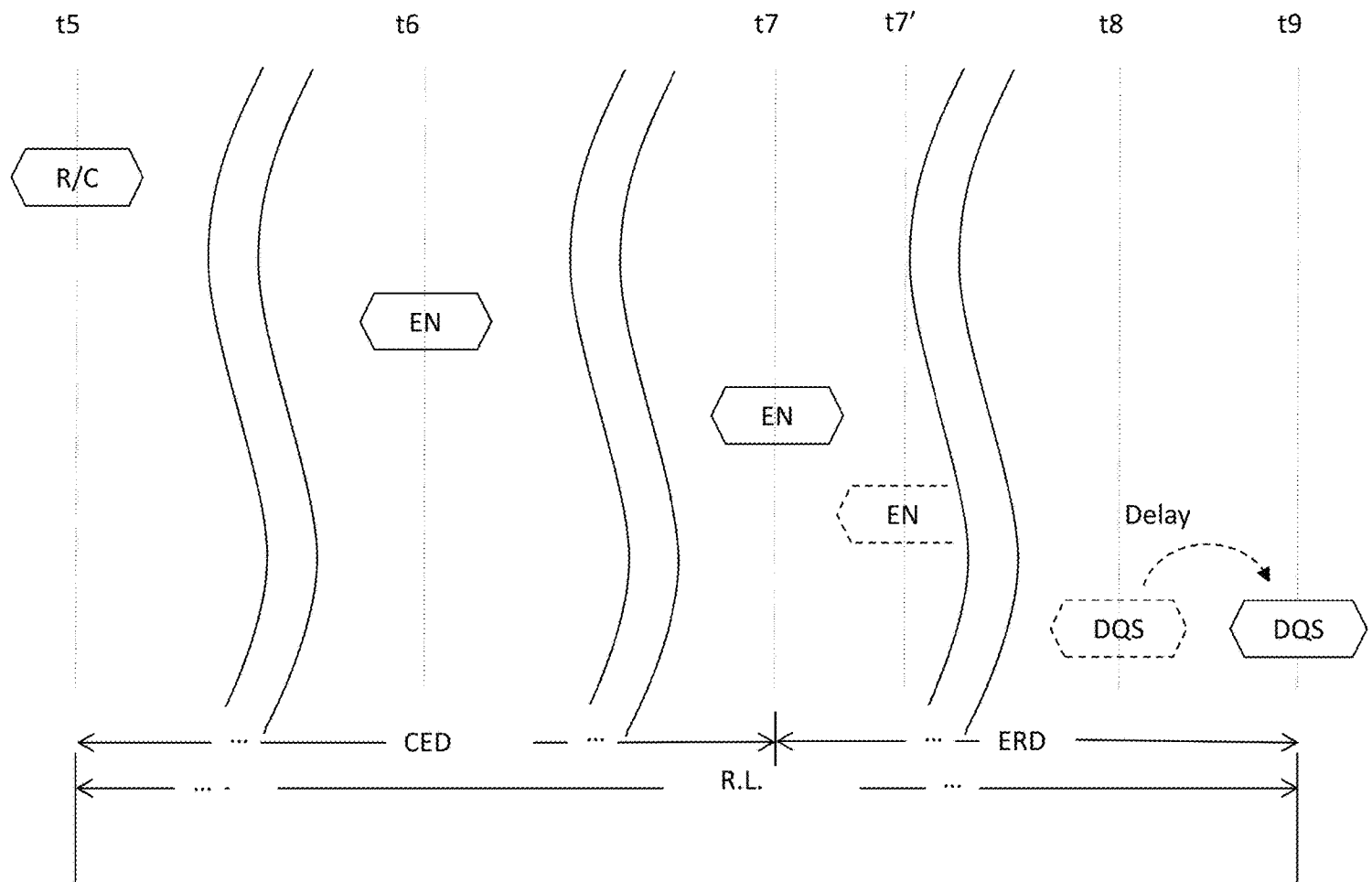

FIG. 12B

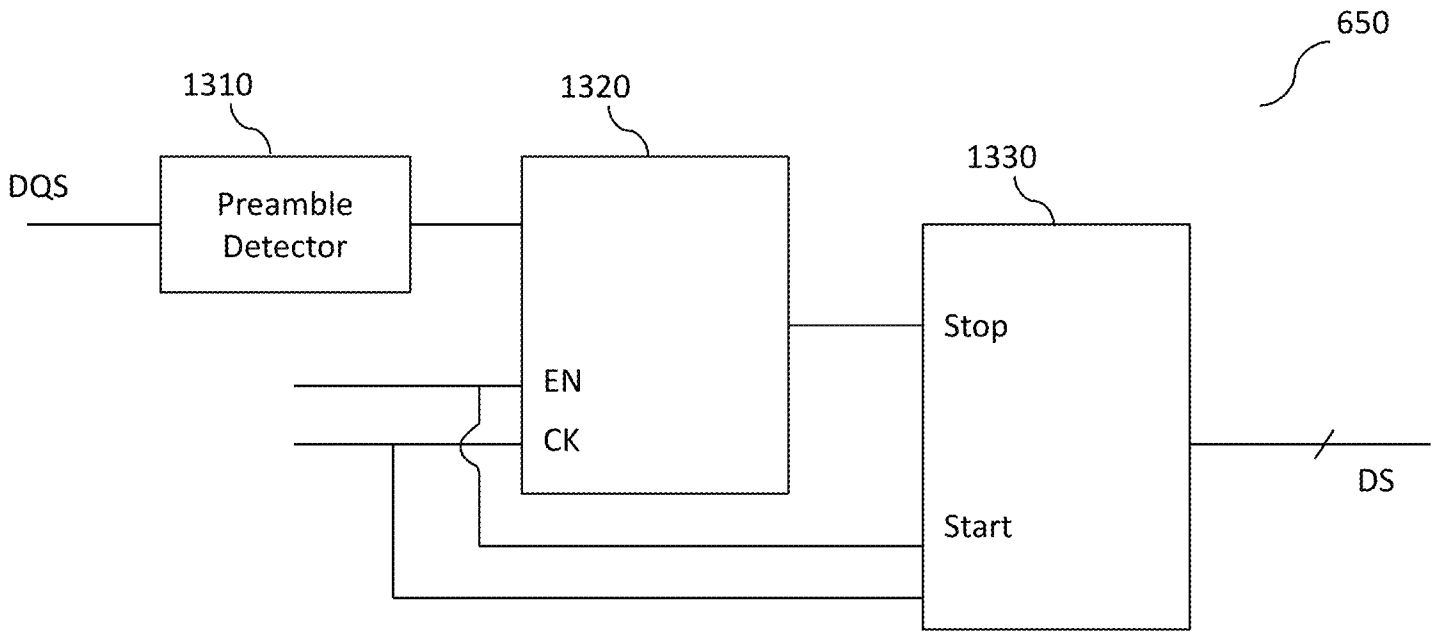

FIG. 13

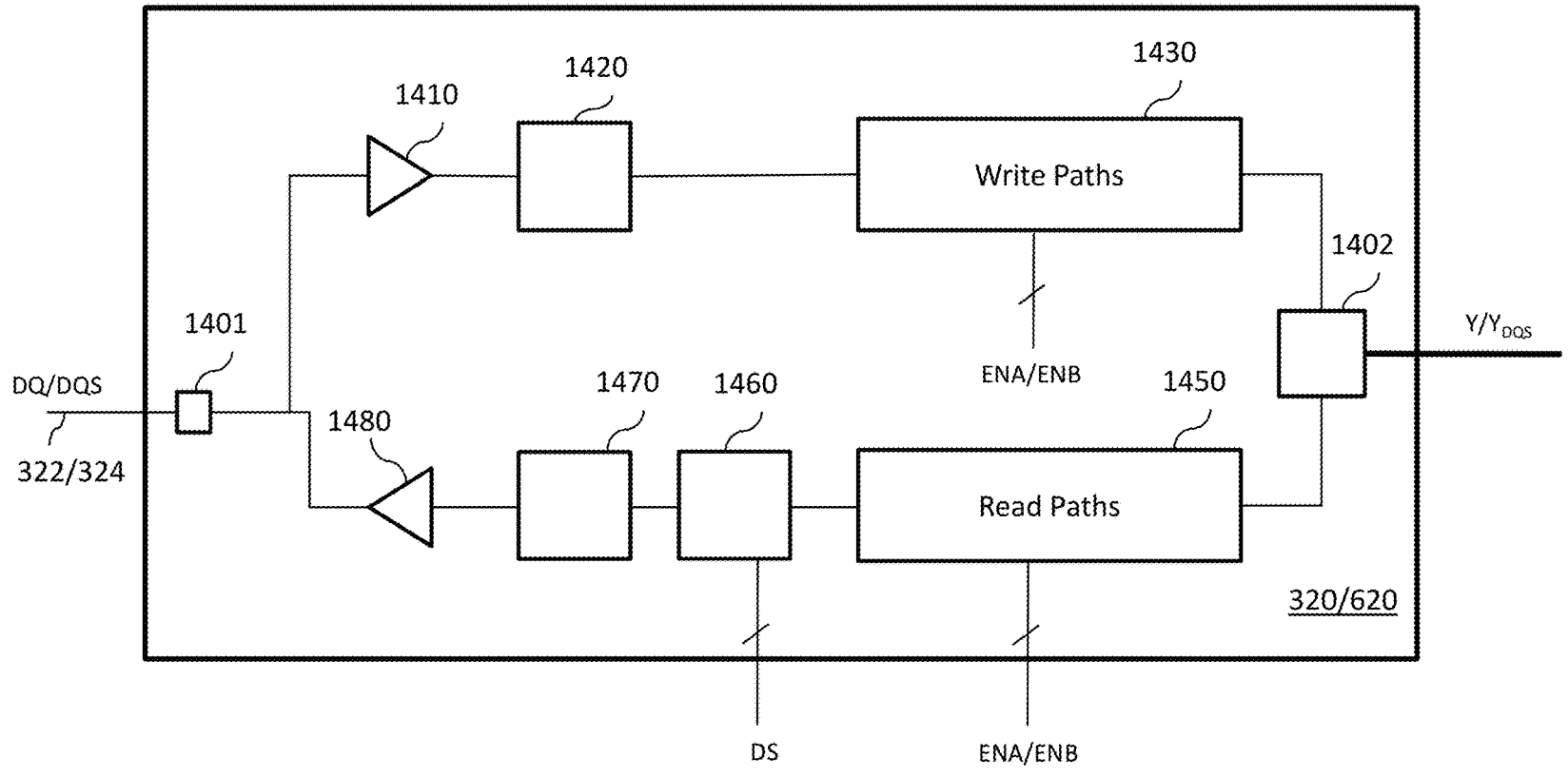

FIG. 14

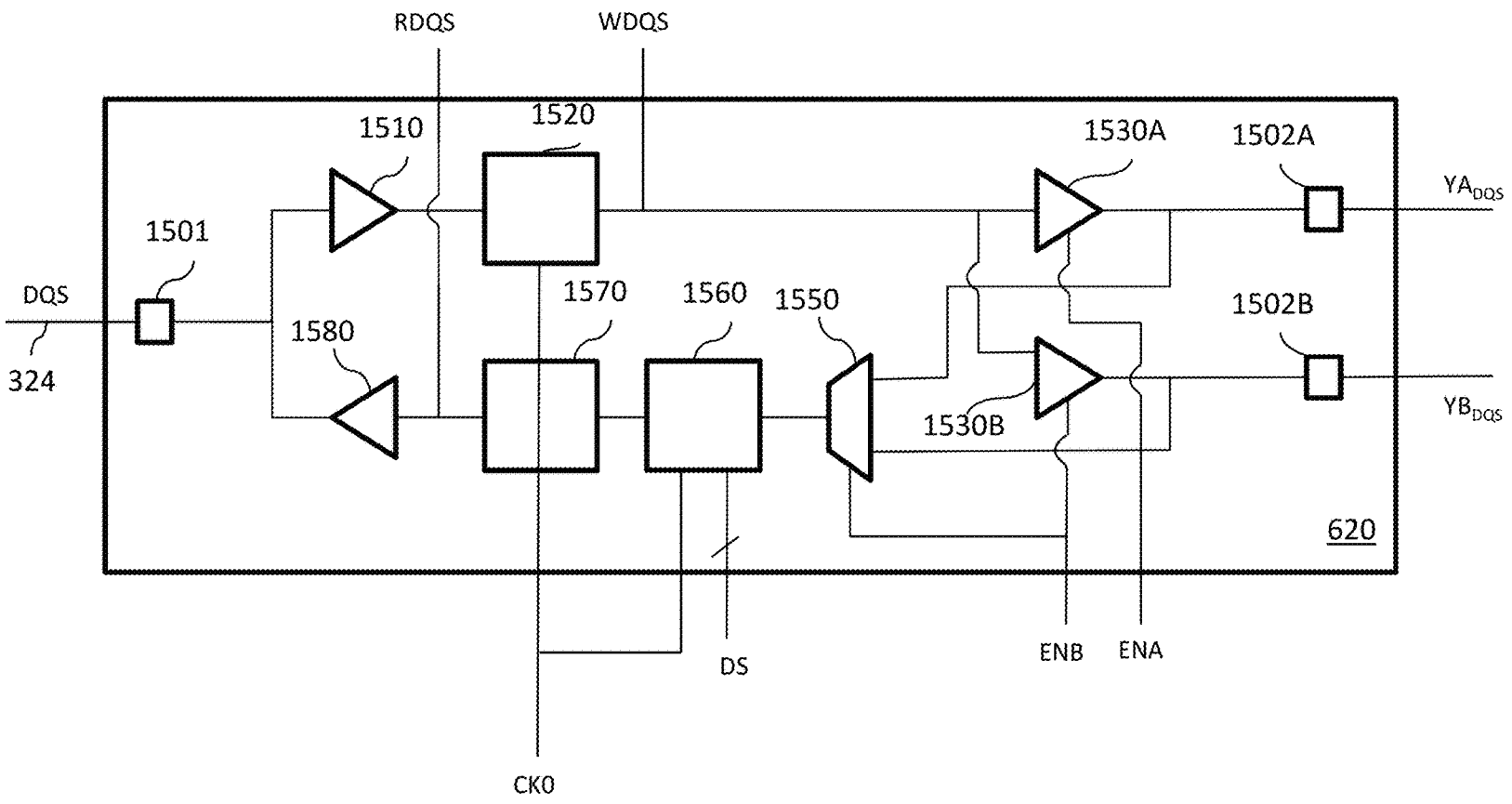

FIG. 15

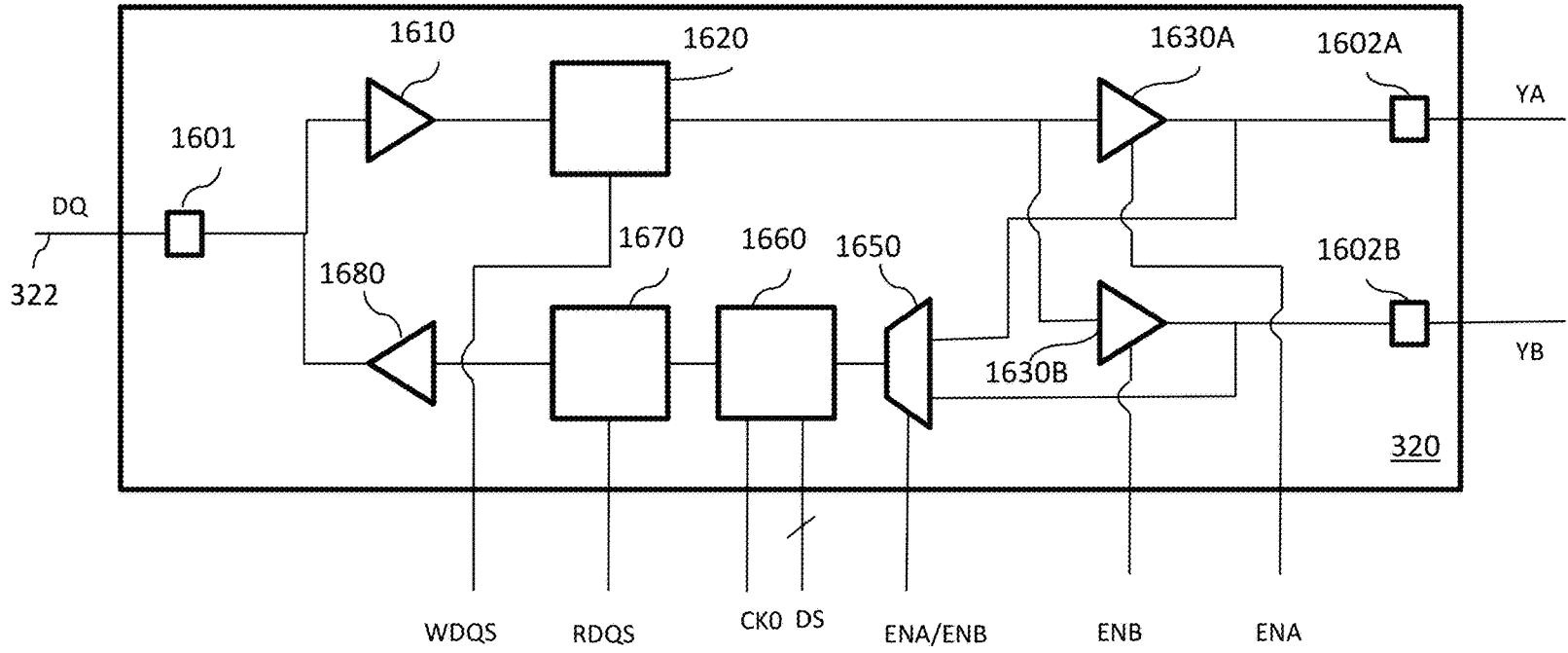

FIG. 16

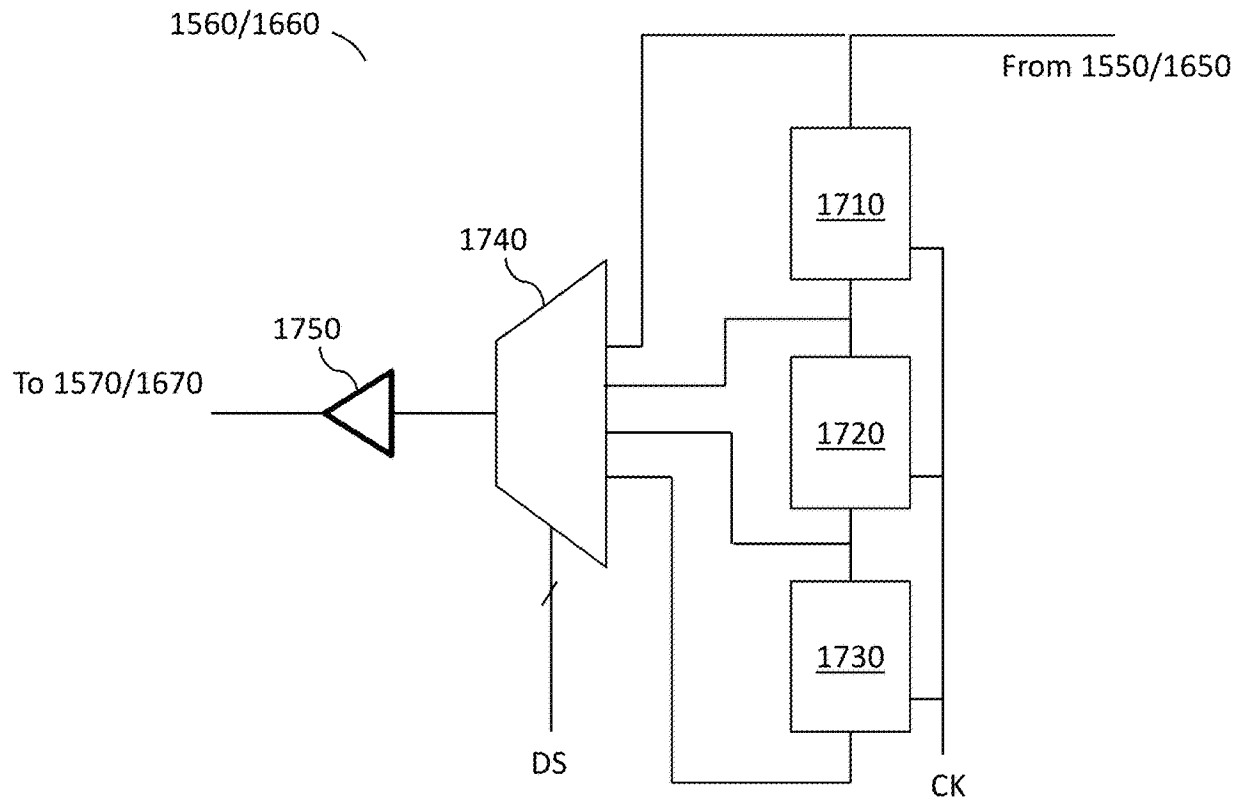

FIG. 17

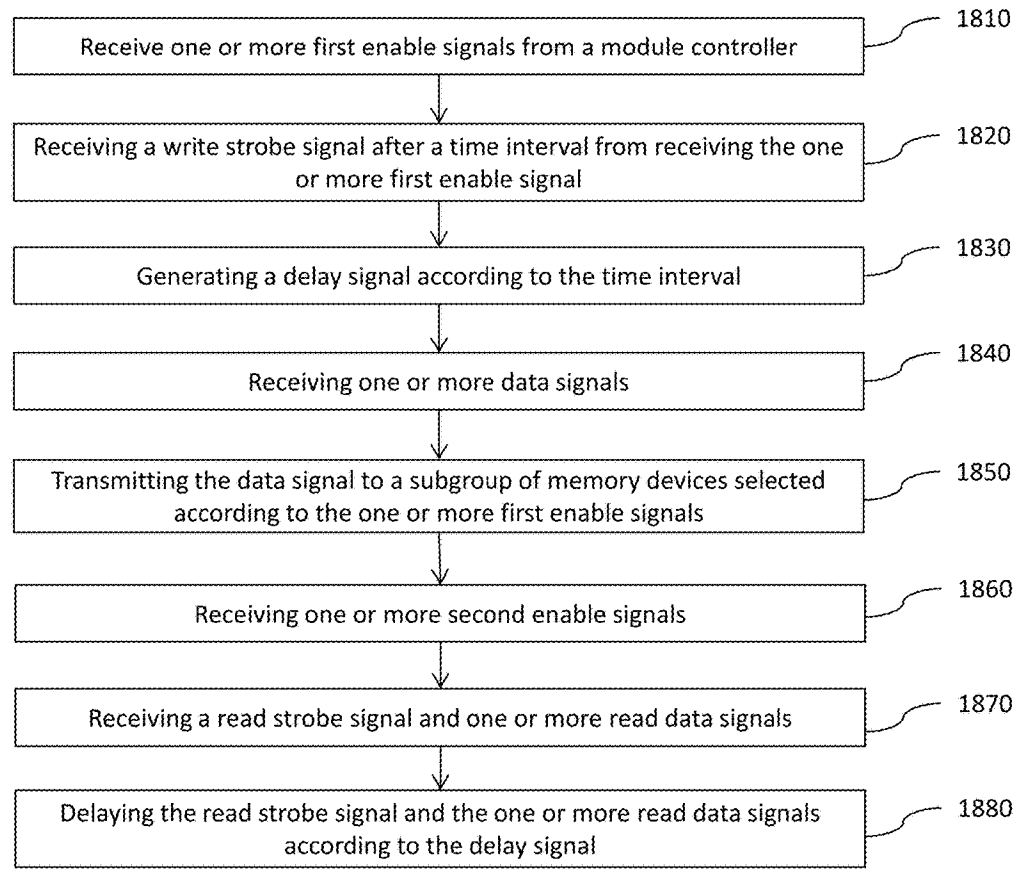

FIG. 18

**MEMORY MODULE WITH
TIMING-CONTROLLED DATA PATHS IN
DISTRIBUTED DATA BUFFERS**

CLAIM OF PRIORITY

The present application is a continuation of U.S. patent application Ser. No. 15/426,064, to be issued as U.S. Pat. No. 9,824,035, which is a continuation of U.S. patent application Ser. No. 14/846,993, now U.S. Pat. No. 9,563,587, which is a continuation of U.S. patent application Ser. No. 13/952,599, filed Jul. 27, 2013, issued as U.S. Pat. No. 9,128,632, which claims priority to U.S. Provisional Pat. Appl. No. 61/676,883, filed on Jul. 27, 2012. Each of the above applications is incorporated herein by reference in its entirety.

CROSS REFERENCE TO RELATED
APPLICATIONS

The present application is related to commonly-owned U.S. patent application Ser. No. 14/715,486, filed on May 18, 2015; U.S. patent application Ser. No. 13/970,606, filed on Aug. 20, 2013; U.S. patent application Ser. No. 12/504,131, filed on Jul. 16, 2009, now U.S. Pat. No. 8,417,870; U.S. patent application Ser. No. 12/761,179, filed on Apr. 15, 2010, now U.S. Pat. No. 8,516,185; U.S. patent application Ser. No. 13/287,042, filed on Nov. 1, 2011, now U.S. Pat. No. 8,756,364; and U.S. patent application Ser. No. 13/287,081, filed on Nov. 1, 2011, now U.S. Pat. No. 8,516,188; each of which is incorporated herein by reference in its entirety.

FIELD

The disclosure herein is related generally to memory modules, and more particularly to multi-rank memory modules and methods of operation.

BACKGROUND

With recent advancement of information technology and widespread use of the Internet to store and process information, more and more demands are placed on the acquisition, processing, storage and dissemination of vocal, pictorial, textual and numerical information by microelectronics-based combination of computing and communication means. In a typical computer or server system, memory modules are used to store data or information. A memory module usually includes multiple memory devices, such as dynamic random access memory devices (DRAM) or synchronous dynamic random access memory devices (SDRAM), packaged individually or in groups, and/or mounted on a printed circuit board (PCB). A processor or a memory controller accesses the memory module via a memory bus, which, for a single-in-line memory module (SIMM), can have a 32-bit wide data path, or for a dual-in-line memory module (DIMM), can have a 64-bit wide data path.

The memory devices of a memory module are generally organized in ranks, with each rank of memory devices generally having a bit width. For example, a memory module in which each rank of the memory module is 64 bits wide is described as having an "x64" or "by 64" organization. Similarly, a memory module having 72-bit-wide ranks is described as having an "x72" or "by 72" organization.

The memory capacity or memory density of a memory module increases with the number of memory devices on the memory module. The number of memory devices of a memory module can be increased by increasing the number of memory devices per rank or by increasing the number of ranks.

In certain conventional memory modules, the ranks are selected or activated by control signals from a processor or memory controller during operation. Examples of such control signals include, but are not limited to, rank-select signals, also called chip-select signals. Most computer and server systems support a limited number of ranks per memory module, which limits the memory density of the memory modules that can be used in these computer and server systems.

For memory devices in such as a memory module to be properly accessed, distribution of control signals and a control clock signal in the memory module is subject to strict constraints. In some conventional memory modules, control wires are routed so there is an equal length to each memory component, in order to eliminate variation of the timing of the control signals and the control clock signal between different memory devices in the memory modules. The balancing of the length of the wires to each memory devices compromises system performance, limits the number of memory devices, and complicates their connections.

In some conventional memory systems, the memory controllers include leveling mechanisms for write and/or read operations to compensate for unbalanced wire lengths and memory device loading on the memory module. As memory operating speed and memory density continue to increase, however, such leveling mechanisms are also insufficient to insure proper timing of the control and/or data signals received and/or transmitted by the memory modules.

BRIEF DESCRIPTION OF THE DRAWINGS

FIG. 1 is a diagram illustrating a memory system including at least one memory module according to one embodiment.

FIGS. 2A-2D are each a diagrams illustrating interactions among components in a a memory module according to certain embodiments.

FIG. 3 is a diagram illustrating one of a plurality of data buffers in a memory module according to one embodiment.

FIGS. 4A-4B are each a diagram illustrating data and data strobe signal lines coupled to memory devices in a memory module according to certain embodiments.

FIGS. 5A-5B are diagrams illustrating different numbers of memory devices that can be coupled to each data buffer in a memory module according to certain embodiments.

FIG. 6 is a diagram illustrating a control circuit in a data buffer according to certain embodiments.

FIG. 7 is a diagram illustrating control signals from a module control device to a plurality of data buffers in a memory module according to certain embodiments.

FIG. 8 is a timing diagram illustrating alignment of module control signals with respect to module clock signals.

FIG. 9 is a diagram illustrating a metastability detection circuit and signal adjustment circuit in a data buffer according to certain embodiments.

FIGS. 10A-10C are diagrams illustrating a metastability detection circuit according to certain embodiments.

FIG. 10D is a diagram illustrating a signal adjustment circuit according to certain embodiments.

FIGS. 11A-11B are diagrams illustrating a metastability detection circuit and signal adjustment circuit, respectively, according to certain embodiments.

FIGS. 12A-12B are a timing diagrams illustrating a write operation and a read operation, respectively, performed by a memory module according to one embodiment.

FIG. 13 is a diagram illustrating a delay control circuit in a data buffer according to certain embodiments.

FIG. 14 is a diagram illustrating a DQ or DQS routing circuit in a data buffer according to an embodiment.

FIG. 15 is a diagram illustrating a DQS routing circuit having a delay circuit in a data buffer according to an embodiment.

FIG. 16 is a diagram illustrating a DQ routing circuit having a delay circuit in a data buffer according to an embodiment.

FIG. 17 is a diagram illustrating a delay circuit in a DQ or DQS routing circuit according to an embodiment.

FIG. 18 is a flowchart illustrating a method for data edge alignment according to embodiments.

FIG. 19 is a diagram illustrating a control circuit in a data buffer according to certain embodiments.

DESCRIPTION OF EMBODIMENTS

A memory module according to one embodiment includes memory devices organized in groups, a module control device, and data buffers (DB). The data buffers are sometimes referred to herein as buffer circuits, isolation devices (I.D.) or load reduction devices. The memory module is operable to perform memory operations in response to memory commands (e.g., read, write, refresh, precharge, etc.), each of which is represented by a set of control/address (C/A) signals transmitted by the memory controller to the memory module. The C/A signals may include, for example, a row address strobe signal (/RAS), a column address strobe signal (/CAS), a write enable signal (/WE), an output enable signal (/OE), one or more chip select signals, row/column address signals, and bank address signals. The memory controller may also transmit a system clock signal to the memory module. In one embodiment, the C/A signals and the system clock signal are received by the module control device, which generates a set of module command signals and a set of module control signals in response to each memory command from the memory controller. The module command signals are transmitted by the module control device to the memory devices via module C/A signal lines, and the module control signals (referred sometimes herein as module control signals) are transmitted by the module control device to the buffer circuits via module control signal lines.

The buffer circuits are associated with respective groups of memory devices and are distributed across the memory module at positions corresponding to the respective groups of memory devices. Thus, during certain high speed operations, each module control signal may arrive at different buffer circuits at different points of time across more than one clock cycle of the system clock. Also, each buffer circuit associated with a respective group of memory devices is in the data paths between the respective group of memory devices and the memory controller. Thus, the memory controller does not have direct control of the memory devices. In one embodiment, each group of memory devices include at least two subgroups, each subgroup including at least one memory device. Each buffer circuit is configured to select a subgroup in the respective group of memory devices to communicate data with the memory controller in response to the module control signals. Thus, the memory

module can have more ranks of memory devices than what is supported by the memory controller.

In one embodiment, each buffer circuit includes metastability detection circuits to detect metastability condition in the module control signals and signal adjustment circuits to adjust the module control signals and/or a module clock signal to mitigate any metastability condition in the module control signals.

Further, in one embodiment, each buffer circuit includes signal alignment circuits that determine, during a write operation, a time interval between a time when one or more module control signals are received from the module control circuit and a time when a strobe or data signal is received from the memory controller. This time interval is used during a subsequent read operation to time transmission of read data to the memory controller, such that the read data arrives at the memory controller within a time limit in accordance with a read latency parameter associated with the memory system.

FIG. 1 shows a system 100 including a memory controller (MCH) 101 and one or more memory modules 110 coupled to the MCH by a memory bus 105, according to one embodiment. As shown, the memory bus includes C/A signal lines 120 and groups of system data/strobe signal lines 130. Also as shown, each memory module 110 has a plurality of memory devices 112 organized in a plurality of ranks 114. Each memory module 110 further includes a module control circuit (module controller or module control device) 116 coupled to the MCH 101 via the C/A signal lines 120, and a plurality of buffer circuits or isolation devices 118 coupled to the MCH 101 via respective groups of system data/strobe signal lines 130. In one embodiment, the memory devices 112, the module control circuit 116 and the isolation devices 118 can be mounted on a same side or different sides of a printed circuit board (module board) 119.

In the context of the present description, a rank refers to a set of memory devices that are selectable by a same chip select signal from the memory controller. The number of ranks of memory devices in a memory module 110 may vary. For example, as shown, each memory module 110 may include four ranks of memory devices 112. In another embodiment, the memory module 110 may include 2 ranks of memory devices. In yet another embodiment, the memory module may include six or more ranks of memory devices 112.

In the context of the present description, a memory controller refers to any device capable of sending instructions or commands, or otherwise controlling the memory devices 112. Additionally, in the context of the present description, a memory bus refers to any component, connection, or groups of components and/or connections, used to provide electrical communication between a memory module and a memory controller. For example, in various embodiments, the memory bus 105 may include printed circuit board (PCB) transmission lines, module connectors, component packages, sockets, and/or any other components or connections that provide connections for signal transmission.

Furthermore, the memory devices 112 may include any type of memory devices. For example, in one embodiment, the memory devices 112 may include dynamic random access memory (DRAM) devices. Additionally, in one embodiment, each memory module 110 may include a dual in-line memory module (DIMM).

Referring to FIG. 2A, which illustrates one memory module 110 according to an embodiment, the module control device 116 receives system memory commands repre-

sented by a set of system control/address (C/A) signals from the MCH 101 via signal lines 120 and generates module command signals and module control signals based on memory commands from the system. The module control device 116 also received a system clock MCK and generates a module clock signal CK in response to the system clock signal MCK. The MCK signal may include a pair of complementary clock signals, MCK and $\overline{\text{MCK}}$, and the module clock signal may include a pair of complementary clock signals CK and $\overline{\text{CK}}$.

Examples of the system C/A signals include, but are not limited to, Chip Select (or /CS) signal, which is used to select a rank of memory devices to be accessed during a memory (read or write) operation; Row Address Strobe (or /RAS) signal, which is used mostly to latch a row address and to initiate a memory cycle; Column Address Strobe (or /CAS) signal, which is used mostly to latch a column address and to initiate a read or write operation; address signals, including bank address signals and row/column address signals, which are used to select a memory location on a memory device or chip; Write Enable (or /WE) signal, which is used to specify a read operation or a write operation, Output Enable (or /OE) signal, which is used to prevent data from appearing at the output until needed during a read operation, and the system clock signal MCK.

Examples of module command signals include, but are not limited to module /CS signals, which can be derived from the system /CS signals and one or more other system C/A signals, such as one or more bank address signals and/or one or more row/column address signals; a module /RAS signal, which can be, for example, a registered version of the system /RAS signal; a module /CAS signal, which can be, for example, a registered version of the system /CAS signal; module address signals, which can be, for example, registered versions of some or all of the address signals; a module /WE signal, which can be, for example, a registered version of the system /WE signal; a module /OE signal, which can be, for example a registered version of the system /OE signal. In certain embodiments, the module command signals may also include the module clock signal CK.

Examples of module control signals include, but are not limited to a mode signal (MODE), which specifies a mode of operation (e.g., test mode or operating mode) for the isolation devices 118; one or more enable signals, which are used by an isolation device to select one or more subgroups of memory devices to communicate data with the memory controller; and one or more ODT signals, which are used by the isolation devices to set up on-die termination for the data/strobe signals. In one embodiment, the module control signals are transmitted to the isolation devices 118 via respective module control signal lines 230. Alternatively, the module control signals can be packetized before being transmitted to the isolation devices 118 via the module control signal lines and decoded/processed at the isolation devices.

Module control device 116 transmits the module command signals to the memory devices 112 via module C/A signal lines 220. The memory devices 112 operate in response to the module command signals to receive write data or output read data as if the module command signals were from a memory controller. The module control device transmits the module control signals together with the module clock signal CK to the isolation devices 118 via module control signal lines 230. As shown in FIG. 2, at least some of the memory devices in a same rank share a same set of

module C/A signal lines 220, and at least some of the isolation devices 118 share a same set of module control signal lines 230.

As shown in FIGS. 2A and 2B, each rank 114 includes N memory devices, where N is an integer larger than one. For example, a first rank includes memory devices $M_{1,1}, \dots, M_{1,N}$, a second rank includes memory devices $M_{2,1}, \dots, M_{2,N}$, and so on. In one embodiment, the memory devices 112 are also organized in groups or sets, with each group corresponding to a respective group of system data/strobe signal lines 130 and including at least one memory device from each rank. For example, memory devices $M_{1,1}, M_{1,2}, M_{1,3}$, and $M_{1,4}$ form a first group of memory devices, memory devices $M_{1,1}, M_{1,2}, M_{1,3}$, and $M_{1,4}$ form an i^{th} group of memory devices, and so on.

As shown, the isolation devices 118 are associated with respective groups of memory devices and are coupled between respective groups of system data/strobe signal lines 130 and the respective groups of memory devices. For example, isolation device ID-1 among the isolation devices 118 is associated with the first group of memory devices $M_{1,1}, M_{1,2}, M_{1,3}$, and $M_{1,4}$ and is coupled between the group of system data/strobe signal lines 130-1 and the first group of memory devices, isolation devices ID- i among the isolation devices 118 is associated with the i^{th} group of memory devices $M_{i,1}, M_{i,2}, M_{i,3}$, and $M_{i,4}$ and is coupled between the group of system data/strobe signal lines 130- i and the i^{th} group of memory devices, and so on.

In one embodiment, each group or sets of memory devices are coupled to the associated isolation device 118 via a set of module data/strobe lines 210. Each group or set of memory devices is organized in subgroups or subsets, with each subgroup or subset including at least one memory device. The subgroups in a group of memory devices may be coupled to the associated isolation device 118 via a same set of module data/strobe lines 210 (as shown in FIG. 2A) or via respective subsets of module data/strobe lines 210 (as shown in FIG. 2B). For example, as shown in FIG. 2B, in the first group of memory devices, memory devices $M_{1,1}$ and/or $M_{1,3}$ form a first subgroup, and memory devices $M_{1,2}$ and/or $M_{1,4}$ form a second subgroup; in the i^{th} group of memory devices, memory devices $M_{i,1}$ and/or $M_{i,3}$ form a first subgroup, and memory devices $M_{i,2}$ and/or $M_{i,4}$ form a second subgroup; and so on. The first subgroup of at least one memory device in each group of memory devices is coupled to the associated isolation device 118 via an associated first subset of module data/strobe lines YA, and the second subgroup of at least one memory device in each group of memory devices is coupled to the associated isolation device via an associated second subset of module data/strobe lines YB, as shown. For example, memory devices $M_{1,1}$ and/or $M_{1,3}$ form the first subgroup are/is coupled to the isolation device ID-1 via the corresponding first subset of module data/strobe lines YA-1, and memory devices $M_{1,2}$ and/or $M_{1,4}$ form the second subgroup are/is coupled to the isolation device ID-1 via the corresponding second subset of module data/strobe lines YA-2.

In one embodiment, the isolation devices 118 are in the data paths between the MCH 101 and the memory module 110 and include data buffers between the MCH 101 and the respective groups of memory devices. In one embodiment, each isolation device 118 is configured to select a subgroup in the respective group of memory devices to communicate data with the MCH 101 in response to the module control signals, such that the memory module can include more ranks than what is supported by the MCH 101. Further, each

isolation devices **118** is configured to isolate unselected subgroup(s) of memory devices from the MCH **101** during write operations, so that the MCH sees a load on each data line that is less than a load associated with the respective group of memory devices. In one embodiment, the MCH

sees only a load associated with one memory device on each data/strobe signal line during write operations. In one embodiment, the isolation devices **118** are distributed across the memory module **110** or the module board **119** in positions corresponding to the respective groups of memory devices. For example, isolation device ID-1 is disposed in a first position corresponding to the first group of memory devices M_{11} , M_{12} , M_{13} , and M_{14} , and isolation device ID- i is disposed in an i^{th} position separate from the first position and corresponding to the i^{th} group of memory devices M_{i1} , M_{i2} , M_{i3} , and M_{i4} . In one embodiment, the first position is between the first group of memory devices and an edge **201** of the module board **119** where connections (not shown) to the data/strobe signal lines **130** are placed, and i^{th} position is between the i^{th} group of memory devices and the edge **201** of the module board **119**. In one embodiment, the isolation devices **118** are distributed along the edge **201** of the memory module **110**. In one embodiment, each isolation device **118** is a separate integrated circuit device packaged either by itself or together with at least some of the respective group of memory devices. In one embodiment, the module data/strobe signal lines **210**, the module C/A signal lines **220**, and the module control signal lines **230** include signal traces formed on and/or in the module board **119**.

As an option, memory module **110** may further include a serial-presence detect (SPD) device **240**, which may include electrically erasable programmable read-only memory (EEPROM) for storing data that characterize various attributes of the memory module **110**. Examples of such data include a number of row addresses, a number of column addresses, a data width of the memory devices, a number of ranks on the memory module **110**, a memory density per rank, a number of memory device on the memory module **110**, and a memory density per memory device, etc. A basic input/output system (BIOS) of system **100** can be informed of these attributes of the memory module **110** by reading from the SPD **240** and can use such data to configure the MCH **101** properly for maximum reliability and performance.

In certain embodiments, the SPD **240** and/or the control circuit **116** store module configuration information, such as: memory space translation code, memory address mapping function code, input and output signals timing control information for the control circuit **116**, input and output signals electrical and logical level control information for the control circuit **116**, etc. In certain embodiments, the SPD **240** contains a system view of the module **110** which can be different from an actual physical construction of the module **110**. For example, the SPD **240** stores at least one memory operation parameter that is different from a corresponding memory operation parameter in a system memory controller setting. The SPD **240** may also store at least on data buffer operation parameter that is different from a corresponding parameter in the system memory controller setting.

Thus, in certain embodiment, in the memory module **110**, C/A signals representing a memory command are received and buffered by the module control circuit **116**, so that the MCH sees only the module control circuit **116** as far as the C/A signals are concerned. Write data and strobe signals from the controller are received and buffered by the isolation devices **118** before being transmitted to the memory devices **112** by the isolation devices **118**. On the other hand, read data and strobe signals from the memory devices are

received and buffered by the isolation devices before being transmitted to the MCH via the system data/strobe signal lines **130**. Thus, MCH **101** does not directly operate or control the memory devices **112**. As far as data/strobe signals are concerned, the MCH **101** mainly sees the isolation devices **118**, and the system **100** depends on the isolation devices **118** to properly time the transmission of the read data and strobe signals to the MCH **101**.

In certain embodiments, the memory module **110** is a dual in-line memory module (DIMM) and the memory devices are double data rate (DDR) dynamic random access memory devices (DRAM). In certain embodiments, the control circuit **116** includes a DDR register, and logic for memory space translation between a system memory domain and a module level physical memory domain. Such translation may produce address mapping, proper interface timing for the control signals to the module level physical memory domain, and a proper interface electrical and logical level for the control signals to the module level physical memory domain.

As shown in FIG. 2C, in certain embodiments, the control circuit **116** transmits registered C/A and clock signals to the memory devices **112**, and transmits module control signals and a registered clock signal (or module clock signal) to the isolation devices **118**, in a fly-by configuration. As the speed of memory operations increase, issues can arise with respect to signal alignment for input, output delay variation due process, voltage and temperature (PVT) variations, synchronization with system memory controller interface, and phase drift accumulation during operation, etc. Electrical interface calibration drift during operation due to charge build up and timing interface calibration drift during operation due to environment change can also create issues.

For example, load reduction mechanism in the isolation devices **118** would provide a single data bus interface to the respective set of memory devices, which is hidden from the system memory controller **101**. Thus, a long sequence of interface timing training may be required due to limited controllability of the system memory controller **101** over the interface between the memory devices **112** and the associated isolation devices **118**. Furthermore, interface signal alignment-drift after the initial training would not be easily detected by the system memory controller **101**, which may cause silent system failure.

Moreover, clock skew amongst the memory devices **112** and the associated isolation devices **118** due to the distributed architecture of the memory module **110** can cause synchronization issues. As the speed of memory operation increase, data period can become very close to the signal propagation delay time. Thus, such issues cannot simply be addressed by pipelining the data paths, as variation of the signal propagation time through I/Os becomes a very significant portion of a data period.

To address at least some of the above issues, in certain embodiments, as shown in FIG. 2D, the control circuit **116** transmits registered C/A signals to the memory devices **112**, and transmits the module control signals and the module clock signal to the data buffers **118**, in a fly-by arrangement. The memory devices **112** do not receive the module clock signal from the control circuit **116**. Instead, each data buffer **118** regenerates the clock that is used by the respective set of memory devices **112**. Each Data buffer **118** is thus responsible for providing a correct data timing interface between the respective set of memory devices **112** and the system memory controller **101**. Each data buffer **118** is also

responsible for providing the correct control signal timing between the control circuit 116 and the respective set of memory devices 112.

Thus, the memory module 110 in FIG. 2D allows a locally synchronized operation for each respective set of memory devices 112, which can correspond to a nibble or a byte of a DDR data bus between the memory module 110 and the system memory controller 101. Also, signal interface between each data buffer 118 and the respective set of memory devices 112 can be synchronized. In one embodiment, each data buffer 118 has a set of configurable operations, including, for example: programmable phase relationship between the clock it receives and the clock it regenerates, programmable phase adjustment for the data and data-strobe signals coupled to the memory devices 112, programmable phase adjustment for the data and data-strobe signals coupled to the system memory controller 101, programmable phase adjustment related to at least one control signal that is coupled to the control circuit 116. The locally synchronized operation also makes it easier for each data buffer 118 to perform self-testing of the associated set of memory devices 112, independent of the self-testing of other sets of memory devices performed by the other data buffers, as disclosed in commonly-owned U.S. Pat. No. 8,001,434, entitled "Memory Board with Self-Testing Capability," which is incorporated herein by reference in its entirety.

In certain embodiments, operations of the isolation devices 118 are controlled by the module control signals from the module control circuit 116, which generates the module control signals according to the C/A signals received from the MCH. Thus, the module control signals need to be properly received by the isolation devices 118 to insure their proper operation. In one embodiment, the module control signals are transmitted together with the module clock signal CK, which is also generated by the module control circuit 116 based on the system clock signal MCK. The isolation circuits 118 buffers the module clock signal, which is used to time the sampling of the module control signals. Since the isolation devices 118 are distributed across the memory module, the module control signal lines 230 can stretch across the memory module 110, over a distance of several centimeters. As the module control signals travel over such a distance, they can become misaligned with the module clock signal, resulting in metastability in the received module control signals. Therefore, in one embodiment, the isolation circuits 118 includes metastability detection circuits to detect metastability condition in the module control signals and signal adjustment circuits to adjust the module control signals and/or the module clock signal to mitigate any metastability condition in the module control signals, as explained in further detail below.

Because the isolation devices 118 are distributed across the memory module 110, during high speed operations, it may take more than one clock cycle time of the system clock MCK for the module control signals to travel along the module control signals lines 230 from the module control device 116 to the farthest positioned isolation devices 118, such as isolation device ID-1 and isolation device ID-(n-1) in the exemplary configuration shown in FIG. 2. In other words, a same set of module control signals may reach different isolation devices 118 at different times across more than one clock cycle of the system clock. For example, when the clock frequency of the system clock is higher than 800 MHz, the clock cycle time is less than about 1.2 ns. With a signal travel speed of about 70 ps per centimeter of signal line, a module control signal would travel about 15 cm during one clock cycle. When the clock frequency increases

to 1600 MHz, a module control signal would travel less than 8 cm during one clock cycle. Thus, a module control signal line can have multiple module control signals on the line at the same time, i.e., before one module control signal reaches an end of the signal line, another module control signal appear on the signal line.

With the isolation devices 118 receiving module control signals at different times across more than one clock cycle, the module control signals alone are not sufficient to time the transmission of read data signals to the MCH 101 from the isolation devices 118. In one embodiment, each isolation devices includes signal alignment circuits that determine, during a write operation, a time interval between a time when one or more module control signals are received from the module control circuit 116 and a time when a write strobe or write data signal is received from the MCH 101. This time interval is used during a subsequent read operation to time the transmission of read data to the MCH 101, such that the read data follows a read command by a read latency value associated with the system 100, as explained in more detail below.

More illustrative information will now be set forth regarding various optional configurations, architectures, and features with which the foregoing framework may or may not be implemented, per the desires of the user. It should be strongly noted that the following information is set forth for illustrative purposes and should not be construed as limiting in any manner. Any of the following features may be optionally incorporated with or without the exclusion of other features described.

In one embodiment, as shown in FIG. 3, each group of signal lines 130 include a set of n data (DQ) signal lines 322 each for transmitting one of a set of data signals $DQ_0, DQ_1, \dots, DQ_{n-1}$, and at least one strobe (DQS) signal line 324 for transmitting at least one strobe signal DQS. Each set of module data/strobe lines Y include a set of n module data signal lines Y_0, Y_1, \dots, Y_{n-1} and at least one module strobe signal line Y_{DQS} . When the subsets of memory devices are coupled to the associated isolation device 118 via respective subsets of memory devices, each set of module data/strobe lines Y may include multiple subsets of module data/strobe lines, such as the subsets of module data/strobe lines YA and YB shown in FIG. 2B. Each subset of module data/strobe lines YA include a set of n first module data lines YA_0, YA_1, \dots, YA_n , and at least one first module strobe signal line YA_{DQS} ; and each subset of module data/strobe lines YB include a set of n second module data lines YB_0, YB_1, \dots, YB_n , and at least one second module strobe signal line YB_{DQS} .

Each isolation device 118 includes a set of DQ routing circuits 320 coupled on one side to respective ones of the set of n DQ signal lines 322, and on another side to respective ones of the respective set of n module data lines, or respective ones of the respective subsets of module data lines, such as the first module data lines YA_0, YA_1, \dots, YA_n , and the second module data lines YB_0, YB_1, \dots, YB_n . Each isolation device 118 further includes an ID control circuit 310 coupled on one side to the at least one DQS signal line 324, on another side to the one or more module strobe signal lines Y_{DQS} , or the first module strobe signal line YA_{DQS} and second module strobe signal line YB_{DQS} . The ID control circuit 310 also receives the module clock signal CK and the module control signals via the module control signal lines 230, and outputs ID control signals 330 to the DQ routing circuits 320, including, for example, one or more enable signals ENA and/or ENB, and some or all of the other received, decoded, and/or otherwise processed module con-

trol signals, a delay signal DS, a read DQS signal RDQS, a write DQS signal WDQS, and a buffer clock signal CK0. Each DQ routing circuit 320 is configured to enable data communication between the respective DQ signal line 322 with a selected subgroup of one or more memory devices in response to the module control signals, as explained in more detail below.

In certain embodiments, the ID control circuit 310 also provides a delay signal DS, which is used by the DQ routing circuits 320 to align read data output by the isolation device 118 with read data output by the other isolation devices 118, as explained in further detail below. In certain embodiments, the ID control circuit 310 regenerates a clock signal from the module clock signal CK, which can have a programmable delay from the module clock signal. The regenerated clock signal is used as the clock signal CK0 and a clock signal CKM that is provided to the corresponding set of memory devices, as explained in more detail below.

The memory devices 112 are coupled to the isolation devices 118 via a same set of module data/strobe signal lines or different subsets of module data/strobe signal lines. For example, as shown in FIG. 4A, memory devices M_{11} , M_{12} , M_{13} , and M_{14} in the first group of memory devices can be coupled to the isolation device ID-1 via a same set of module data lines $Y-1_0$, $Y-1_1$, . . . , $Y-1_{n-1}$ and module strobe line $Y-1_{DQS}$. In such embodiment, a subgroup in the group of memory devices can be selected by the isolation devices to communicated data with the MCH based on the phases of the data/strobe signals, which can be different with respect to different subgroups of memory devices.

Alternatively, as shown in FIG. 4B, memory devices M_{11} and M_{13} , which form a subgroup in the first group of memory devices, are coupled to the isolation device ID-1 via the module data lines $YA-1_0$, $YA-1_1$, . . . , $YA-1_n$ and module strobe line $YA-1_{DQS}$ and memory devices M_{12} and M_{14} , which form another subgroup in the first group of memory devices, are coupled to the isolation device ID-1 via the module data lines $YB-1_0$, $YB-1_1$, . . . , $YB-1_n$ and module strobe line $YB-1_{DQS}$. Memory devices coupled to the same isolation devices can be disposed on a same side or different sides of the memory board 119. Memory devices coupled to the same isolation devices may be placed side by side, on opposite sides of the module boards 119, or stacked over each other, and/or over the associated isolation device.

Multiple memory devices having a data width that is less than a data width of the isolation devices 118 may be used in place of one of the memory devices 112, which has the same data width as that of the isolation devices. For example, as shown in FIG. 5A, two memory devices M_{11-1} and M_{11-2} may be used in place of the memory device M_{11} . Each of the two memory devices M_{11-1} and M_{11-2} has a data width of 4, and together they act like a memory device M_{11} of a data width of 8. Thus, memory device M_{11-1} is coupled to the isolation device ID-1 via module data lines $YA-1_0$, . . . , $YA-1_3$ and module strobe line $YA-1_{DQS-1}$ while memory circuit M_{11-2} is coupled to the isolation device ID-1 via module data lines $YA-1_4$, . . . , $YA-1_7$ and module strobe line $YA-1_{DQS-2}$.

In another embodiment, as shown in FIG. 5B, four memory devices M_{11-1} to M_{11-4} may be used as the memory device M_{11} . Each of the four memory devices M_{11-1} to M_{11-4} has a data width of 4, and together they act like a memory device M_{11} of a data width of 16. Thus, memory device M_{11-1} is coupled to the isolation device ID-1 via module data lines $YA-1_0$, . . . , $YA-1_3$ and module strobe line $YA-1_{DQS-1}$ while memory device M_{11-2} is coupled to the isolation

device ID-1 via module data lines $YA-1_4$, . . . , $YA-1_7$ and module strobe line $YA-1_{DQS-2}$, and so on.

FIG. 6 illustrates the ID control circuit 310 in an isolation device 118. As shown, the ID control circuit 310 includes a clock buffer 610 to receive the module clock signal CK from the module control device 116, and to output a module clock signal CK0. The ID control circuit 310 further includes a strobe routing circuit 620 that are coupled on one side to the corresponding system DQS signal line 324 and on another side to the corresponding module DQS signal lines YA_{DQS} and YB_{DQS} . The ID control circuit 310 further includes a receiver circuit 630 with respect to each of at least some of the module control signals (MCS) to receive a respective one of the module control signals. The ID control circuit 310 further includes a command processing circuit 640 that provides the received, decoded, and/or otherwise processed module control signals 330 to the DQ routing circuits 320 and the strobe routing circuit 620 either directly or after further processing, if needed. The received/decoded/processed module control signals may include, for example, one or more enable signals ENA and/or ENB that are used by the DQ routing circuits 320 and the strobe routing circuit 620 to selectively enabling data communication between the MCH 101 and one of the subgroups in the respective group of memory devices, with which the isolation device is associated.

The strobe routing circuit 620 also buffers strobe signals received from either the MCH 101 or the memory devices 112, and output either a write strobe WDQS or read strobe RDQS to the DQ routing circuits 320. In one embodiment, the ID control circuit 310 further includes a delay control circuit 650 that receives one of the module control signals and either a data signal or a strobe signal and determines a delay amount to be used by the DQ routing circuit 320 and the strobe routing circuit 620. The delay amount is provided to the DQ routing circuit 320 and the strobe routing circuit in a delay signal DS.

In a receiver circuit 630, the respective MCS is received in accordance with the module clock signal CK0. In one embodiment, receiver circuit 630 samples the respective MCS using rising (or falling) edges of the module clock CK0. Since the isolation devices 118 are distributed across the memory module 110 at positions corresponding to the respective groups of memory devices, the module control signal lines 230 that carry the MCS to the isolation devices can stretch over a distance of more than 10 centimeters, as shown in FIG. 7. As the MCS and CK0 travel along their respective module control signal lines 710 and 720, they can become misaligned with each other when they reach the input pins 730 of an isolation device 118.

For example, a module control signal, like the MCS 810 shown in FIG. 8, can be perfectly aligned with the module clock signal CK, with a rising edge 801 of the module clock signal CK being at a center of a data eye 802, when the MCS signal and the clock signal leave the module control circuit 116. When the module control signal and the module clock signal reach an isolation device, however, their alignment can become shifted like the MCS 820 with respect to the CK signal, i.e., the rising edge 801 of the clock signal is near a left edge of a data eye of the MCS 820, barely providing enough set up time for proper sampling of the module control signal. Or, the module control signal, like the MCS 830, can be shifted with respect to the module clock signal such that a rising edge 801 of the clock signal is near a right edge of a data eye of the MCS, barely providing enough hold time for proper sampling of the module control signal. Or, ever worse, the module control signal, like the MCS 840,

can be so shifted with respect to the module clock signal such that a rising edge 801 of the clock signal falls in the glitches 803 at the edge of a data eye of the MCS, meaning that the sampled results could be metastable.

In one embodiment, as shown in FIG. 9, a receiver circuit 630 includes a metastability detection circuit (MDC) 910 to determine a metastability condition in a corresponding module control signal MCS0. In one embodiment, the MDC 910 generates at least one delayed version of the module clock signal CK and at least one delayed version of the corresponding MCS0. The MDC 910 also generates one or more metastability indicators and outputs the one or more metastability indicators via lines 912 and/or 914.

The receiver circuit 630 further includes a signal selection circuit 920 that receives the module clock CK and the at least one delayed version of the module clock via signal lines 916. The signal selection circuit 920 also receives the corresponding MCS and the at least one delayed version of the corresponding MCS via signal lines 918. The signal selection circuit 920 selects a clock signal CK_i from among the module clock CK and the at least one delayed version of the module clock based on one or more of the metastability indicators. The signal selection circuit 920 may also select an MCS signal MCS_i from among the corresponding MCS and the at least one delayed version of the corresponding MCS based on at least one other metastability indicator.

The receiver circuit 630 further includes a sampler or register circuit 930 that samples the selected module control signal MCS_i according to the selected clock signal CK_i and outputs the sampled signal as the received module control signal, which is provided to the command processing circuit 640 for further processing (if needed) before being provided to the DQ routing circuits 320 and DQS routing circuit 620.

FIG. 10A illustrates an MDC 910 according to one embodiment. As shown, the MDC 910 includes a delay circuit 1012 that generates a delayed version MCS1 of the corresponding MCS0 by adding a predetermined amount of delay (e.g., 10 ps) to MCS0. MDC 910 also includes a delay circuit 1016 that generates a delayed version CK1 of the clock signal CK0 by adding a predetermined amount of delay to CK0. In one embodiment, CK1 is delayed from CK0 by about 1/10th of a clock cycle, e.g., 50-70 ps for an operating frequency of about 1600 MHz. The MDC 910 further includes a sampler circuit 1042 that samples MCS1 according to CK0 and outputs a sampled result A, a sampler circuit 1044 that samples MCS0 according to CK0 and outputs a sampled result B, and a sampler circuit 1046 that samples MCS0 according to CK1 and outputs a sampled result C. The MDC 910 further includes a logic circuit (e.g., a majority decision circuit) that generates metastability indicators Z1 and Z2 based on the sampled results A, B, and C.

In one embodiment, Z1 is the result of a logic operation (e.g., an XNOR operation) on the sampled result, e.g., $Z1 = \overline{A \oplus B}$, and Z2 is the result of another logic operation on the sampled results, e.g., $Z2 = B \oplus \overline{C}$. Thus, as shown in FIG. 10B and Table 1 below, when a metastability condition of insufficient hold time occurs, i.e., a rising clock edge 1061 of CK0 is close to the right side of a data eye where glitches at the edges of the data eyes can make C unpredictable, A and B can be in agreement (i.e., Z1 is true) while B and C are likely not in agreement (i.e., Z2 is false). FIG. 10C illustrates a metastability condition when there is insufficient set-up time. As shown in FIG. 10C and Table 1 below, a rising clock edge 1061 of CK0 is close to the left side of a data eye where glitches at the edges of the data eyes can make A unpredictable. Thus, A and B can be in disagreement so

Z1 is false while B and C can be in agreement so Z2 is true. Not shown in the figures is the situation that all A, B, and C are in agreement, meaning that both the rising clock edge 1061 of CK0 and the rising clock edge 1062 of CK1 are near the middle of an MCS0 data eye so there is no metastability issues and both Z1 and Z2 are true, as shown in Table 1.

FIG. 10D illustrates a signal selection circuit 920 according to an embodiment. As shown, in one embodiment, the signal selection circuit 920 includes a first multiplexor 1071 that selects between CK0 and CK1 based on the metastability indicator Z1, and a second multiplexor 1072 that selects between MCS0 and MCS1 based on the metastability indicator Z2. Thus, as shown in Table 1, where a metastability condition of insufficient hold time occurs, Z1=1 and Z2=0, and MCS1 is output from multiplexor 1071 while CK0 is output from multiplexor 1072. Sampler 930 thus samples MCS1 according to the rising edges of CK0. Thus, more hold time is provided to mitigate the metastability condition since MCS1 is shifted from MCS0 toward the right.

On the other hand, where a metastability condition of insufficient set-up time occurs, Z1=0 and Z2=1, and CK1 is output from multiplexor 1071 while MCS0 is output from multiplexor 1072. Sampler 930 thus samples MCS0 according to the rising edges of CK1. Since CK1 is shifted from CK0 toward the right, more set-up time is provided to mitigate the metastability condition.

TABLE 1

Metastability Detection and Signal Selection								
Sampler Output			MS Indicators			Signal Selection		
A	B	C	Z1	Z2	MS Condition	CK	MCS	
D1	D1	D2	1	0	insufficient hold time	CK0	MCS1	
D1	D2	D2	0	1	insufficient set-up time	CK1	MCS0	
D1	D1	D1	1	1	no metastability	CK0	MCS0	

In the case when no metastability is detected, Z1=1 and Z2=1, and CK0 is output from multiplexor 1071 while MCS0 is output from multiplexor 1072. So, the unshifted module control signal is sampled according to the unshifted module clock signal.

FIGS. 10A-10D illustrate a relatively simple implementation of the metastability detection circuit (MDC) 910 where only three different sample points are provided to detect metastability condition in the module control signal. In general, the MDC 910 may generate more delayed versions of the module clock signal CK0 and/or the corresponding module control signal MCS0, and may include more sampler circuits to sample any additional delayed versions of the module control signal according to either the module clock signal or one of the delayed versions of the module clock signal. For example, as shown in FIG. 11A, the MDC 910 can include a plurality of delay circuits 1102 that generate m delayed versions of MCS0, e.g., MCS1, MCS2, . . . MCSm, and m delayed versions of CK0, e.g., CK1, CK2, . . . , CKm. The MDC 910 can include sampler circuits 1104 that sample MCS0 according to CK0, CK1, . . . , CKm, respectively, and sampler circuits 1104 that sample MCS0, MCS1, MCS2, . . . MCSm according to CK0, respectively. The outputs of the samplers 1104 are provided to a logic circuit 1120, which determines a metastability condition in MCK0 based on the sampler outputs using, for

example, a majority decision logic. The logic circuit **1120** outputs a first metastability indicator on line(s) **912** and a second metastability indicator on line(s) **914**.

FIG. **11B** illustrates a signal selection circuit **920** according to an embodiment. As shown, in one embodiment, the signal selection circuit **920** includes a first multiplexor **1171** that selects between **CK0**, **CK1**, . . . , **CKm** based on the metastability indicator provided on line(s) **912**, and a second multiplexor **1172** that selects between **MCS0**, **MCS1**, . . . , **MCSm** based on the metastability indicator provided on line(s) **914**, such that the rising edges of the selected clock signal, e.g., **Cki**, are close to the middle of the respective data eyes in the selected module control signal, e.g., **MCSi**. The selected signals **MCSi** and **Cki** are provided to the sampler **930**, which samples **MCSi** according to the rising edges of **CKi**.

As stated above, in certain embodiments, since the isolation devices **118** are in the data paths between the MCH **101** and the respective groups of memory devices **112**, the MCH **101** does not have direct control of the memory devices **112**. Thus, conventional read/write leveling techniques are not sufficient for managing read/write data timing. In one embodiment, the isolation devices **118** includes signal alignment mechanism to time the transmission of read data signals based on timing information derived from a prior write operation, as discussed further below.

FIG. **12A** is a timing diagram for a write operation according to one embodiment. As shown, after a write command **W/C** associated with the write operation is received by the module control circuit **116** at time **t1**, the module control circuit **116** outputs one or more enable signals **EN** at time **t2** in response to the write commands. The one or more enable signals are received by an isolation device **118** at time **t3'**, which afterwards receives one or more strobe signal **DQS** from the MCH **101** at time **t4**. Note that the same enable signal may be received by another isolation device **118** at time **t3'**, which can be in a different cycle of the system clock **MCK** from the cycle which **t3** is in. The time interval between **t4** and **t1** is consistent with a write latency **W.L.** associated with the system **100**, and is controllable by the MCH **101** and knowable to the isolation device **118**. The time interval between **t4** and **t3**, referred to hereafter as an enable-to-write data delay **EWD**, can be determined by the isolation device **118** since both these signals are received by the isolation device. Based on such determination, the isolation device **118** can have knowledge of the time interval between **t3** and **t1**, referred to hereafter as a command-to-enable delay **CED**, which can be used by the isolation device **118** to properly time transmission of read data to the MCH, as explained further below.

FIG. **12B** is a timing diagram for a read operation according to one embodiment. As shown, after a read command **R/C** associated with the read operation is received by the module control circuit **116** at time **t5**, the module control circuit **116** outputs one or more enable signals **EN** at time **t6** in response to the read commands. The one or more enable signals are received by an isolation device **118** at time **t7**, which afterwards receives at time **t8** read data signals (not shown) and one or more strobe signal **DQS** from the respective group of memory devices. Note that the same enable signal may be received by another isolation device **118** at time **t3'**, which can be in a different cycle of the system clock **MCK** from the cycle which **t3** is in. Thus, the enable signals alone cannot be used to time the transmission of the read signals by the isolation devices **118**.

With knowledge of the time interval between **t7** and **t5**, which should be about the same as the time interval between

t3 and **t1**, i.e., the command-to-enable delay **CED**, in certain embodiments, the isolation device can add a proper amount of delay to the read data signals and the one or more **DQS** signal such that the read data signals and the one or more **DQS** signal are transmitted at time **t9** by the isolation device to the MCH **101** via the respective group of data/strobe signal lines **130**, with the time interval between **t9** and **t5** being consistent with a read latency **R.L.** associated with the system **100**.

The time interval between **t4** and **t3**, i.e., the enable to write data delay **EWD**, is determined by the delay control circuit **650** in the ID control circuit **310**, as shown in FIG. **6**. According to one embodiment, as shown in FIG. **13**, the delay control circuit **650** includes a preamble detector **1310** to detect a write preamble in the **DQS**, a flip-flop circuit **1320** having an enable input **EN** receiving one of the module control signals and a clock input **CK** receiving the buffered module clock signal **CK0**, and a counter circuit **1330** having a Start input receiving the one of the module control signals, a Stop input receiving an output of the flip-flop circuit **1320**. Thus, the output of the counter circuit, i.e., the delay signal **DS**, would indicate a time interval from when the write preamble is detected and when the one of the module control signal is received.

FIG. **14** illustrates a **DQ** or **DQS** routing circuit **320** or **620** according to an embodiment. As shown, the **DQ/DQS** routing circuit **320/620** includes a **DQ/DQS** pin **1401** that is coupled to the corresponding **DQ/DQS** signal line **322/324**, a set of one or more **DQS** pins **1402** that is coupled to a corresponding module **DQ/DQS** line(s) **Y/Y_{DQS}**, or **YA/YA_{DQS}** and **YB/YB_{DQS}**. The **DQ/DQS** routing circuit **320/620** further includes a write strobe buffer **1410** that buffers write data/strobe, and a write data/strobe receiver **1420** that samples the write data/strobe. The **DQ/DQS** routing circuit **320/620** further includes a plurality of write paths **1430** that are selectable or can be selectively enabled by one or more of the module control signals, such as the enable signals **ENA** and **ENB**.

The **DQS** routing circuit further includes a plurality of read paths **1450** that are selectable by the one or more of the module control signals. Output from the selected read path is delayed in a delay circuit **1460** by an amount controlled by the delay signal **DS**, and sampled by a sampler circuit **1470**. The sampled read data/strobe is transmitted by transmitter **1480** onto the corresponding data/strobe signal line **322/324** via the **DQ/DQS** pin **1401**.

FIG. **15** illustrates a **DQS** routing circuit **620** according to an embodiment. As shown, the **DQS** routing circuit **620** includes a first **DQS** pin **1501** that is coupled to a corresponding **DQS** signal line **324**, a second **DQS** pin **1502A** that is coupled to a corresponding module **DQS** line **YA_{DQS}**, a third **DQS** pin **1502B** that is coupled to a corresponding module **DQS** line **YB_{DQS}**. The **DQS** routing circuit **620** further includes a first write strobe path coupled between the first **DQS** pin **1501** and the second **DQS** pin **1502A** and a second write strobe path coupled between the first **DQS** pin **1501** and the third **DQS** pin **1502B**. The first write strobe path includes a write strobe buffer **1510** that buffers a write strobe, a write strobe receiver **1520** that samples the write strobe according to the buffered module signal **CK0**. The sampled write strobe is provided to the **DQ** routing circuits **320** as the write strobe **WDQS**. The first write strobe path further includes a first write strobe transmitter **1530A** that transmits the write strobe to one or more memory devices **112** coupled to the module strobe line **YA_{DQS}**. The second write strobe path includes the write strobe buffer **1510**, the write strobe receiver **1520**, and a second write strobe trans-

17

mitter **1530B** that transmits the write strobe to one or more memory devices **112** coupled to the module strobe line YB_{DQS} . The first and second write strobe transmitters, **1530A** and **1530B**, are controlled by two enable signals, ENA and ENB, respectively, such that the first write strobe path and the second write strobe path can be selectively enabled/disabled by the enable signals, ENA and ENB.

The DQS routing circuit further includes a read strobe path coupled between the first DQS pin **1501** and a selected one of the second and third DQS pins **1502A** and **1502B**. In the read strobe path, a select circuit **1550** (e.g., a multiplexor) selects either a read strobe signal received via DQS pin **1502A** or a read strobe signal received via DQS pin **1502B** based on one or both of the enable signals ENA or ENB. The selected read strobe signal is delayed in a delay circuit **1560** by an amount controlled by the delay signal DS, and sampled by a sampler circuit **1570** according to the buffered module clock signal CK0. The sampled read strobe is provided to the DQ routing circuits **320** as the read strobe RDQS and is transmitted by transmitter **1580** onto the corresponding strobe signal line **324** via the first DQS pin **1501**.

FIG. **16** illustrates a DQ routing circuit **320** according to an embodiment. As shown, the DQ routing circuit **320** includes a first DQ pin **1601** that is coupled to a corresponding DQ signal line **130**, a second DQ pin **1602A** that is coupled to a corresponding module DQ line YA_{DQ} , a third DQ pin **1602B** that is coupled to a corresponding module DQ line YB_{DQ} . The DQ routing circuit **320** further includes a first write data path coupled between the first DQ pin **1601** and the second DQ pin **1602A** and a second write data path coupled between the first DQ pin **1601** and the third DQ pin **1602B**. The first write data path includes a write data buffer **1610**, a write data receiver **1620** that samples write data according to the write strobe WDQS from the DQS routing circuit **620**, and a first write data transmitter **1630A** that transmits the write data to one or more memory devices **112** coupled to the module data line YA_{DQ} . The second write data path includes the write data buffer **1610**, the write data receiver **1620**, and a second write data transmitter **1630B** that transmits the write data to one or more memory devices **112** coupled to the module data line YB_{DQ} . The first and second write data transmitters, **1530A** and **1530B**, are controlled by two enable signals, ENA and ENB, respectively. Thus, the first write data path and the second write data path can be selectively enabled/disabled by the enable signals, ENA and ENB.

The DQ routing circuit further includes a read data path coupled between the first DQ pin **1601** and a selected one of the second and third DQ pins **1602A** and **1602B**. In the read data path, a select circuit **1650** (e.g., a multiplexor) selects either a read data signal received via DQ pin **1602A** or a read data signal received via DQ pin **1602B** based on one or both of the enable signals ENA or ENB. The selected read data signal is delayed in a delay circuit **1660** by an amount controlled by the delay signal DS. The delayed read data signal is then sampled by a receiver circuit **1670** according to the read strobe RDQS from the DQS routing circuit **620**, and transmitted by transmitter **1680** onto the corresponding data signal line **130** via the first DQ pin **1601**.

FIG. **17** illustrate a delay circuit **1560** or **1660** according to an embodiment. As shown, the delay circuit **1560** or **1660** includes a plurality of delay stages, such as delay stages **1710**, **1720**, and **1730**, each delaying a read data or read strobe signal from the select circuit **1550/1650** by a predetermined amount. The delay circuit **1560** or **1660** further includes a select circuit **1740** (e.g., a multiplexor) that

18

selects from among the read data or read strobe signal and the outputs from the delay stages according to the delay signal DS. The output of the select circuit **1740**, is provided to the sampler circuit **1570** or **1670**, either directly or after being buffered by a buffer circuit **1750**.

Thus, as shown in FIG. **18**, in one embodiment, a memory module **110** operates in the memory system **100** according to a method **1800**. In the method, during a write operation, one or more module control signals are received by an isolation device **118** from a module control circuit or module controller **116** (**1810**). The module controller **116** generates the one or more module control signals in response to C/A signals representing a write command from the MCH **101**. The one or more module control signals are used to control the isolation device **118**. For example, the one or more module control signals may include one or more first enable signals to enable a write path to allow write data be communicated to a selected subgroup of memory devices among the group of memory devices coupled to the isolation device **118**. After a time interval from receiving the one or more first enable signals, write data DQ and write strobe DQS are received by the isolation device **118** from the MCH **101** (**1820**). In one embodiment, upon receiving the one or more first enable signal, a counter is started, which is stopped when the write data DQ or write strobe DQS is received. Thus, a time interval EWD between receiving the one or more first enable signals and receiving the write strobe signal DQS is recorded.

Since the time interval between the arrival of the command signals from the MCH **101** and the arrival of the write data/strobe signal DQ/DQS from the MCH **101** is a set according to a write latency parameter associated with the system **100**, the time interval EWD can be used to ascertain a time interval CED between the time when a command signal is received by the memory module **110** and the time when the one or more enable signals are received by the isolation device **118**. The time interval CED can be used by the isolation device **118** to properly time the transmission of read data to the MCH **101**, as described above and explained further below.

As shown in FIG. **18**, a delay signal DS is generated according to the time interval EWD (**1830**). Concurrent to receiving the write strobe signal DQS, the isolation device **118** also receives a set of write data signals DQ (**1840**). The received write data signals are transmitted to the subgroup of memory devices (**1850**), which are selected from the group of memory devices coupled to the isolation device **118** by the one or more first enable signals.

During a read operation, another set of module control signals including, for example, one or more second enable signals, are received by the isolation device **118** from the module controller **116** (**1860**). The one or more second enable signals are generated by the module controller **116** in response to read command signals received from the MCH **101**, and are used by the isolation device **118** to select a subgroup of memory devices from which to receive read data. Afterwards, a read strobe signal DQS and a set of read data signal DQ are received from the selected subgroup of memory devices (**1870**). To properly time the transmission of the DQS and DQ signals to the MCH **101**, the DQS and DQ signals are adjusted (e.g., delayed) according to the delay signal DS, such that the DQS and DQ signals follow a read command by a time interval consistent with a read latency parameter associated with the system **100**.

In certain embodiments, especially the embodiments shown in FIG. **2D**, the delay circuits **1560** and **1660** shown in FIGS. **15** and **16** are not needed to provide alignment of

the read data. As shown in FIG. 19, the ID control circuit 310 includes a clock regeneration circuit 1920 that regenerates the clock signal CK received from the control circuit 116, according to the delay signal DS. The regenerated clock signals CK0 and CKM each includes a proper amount of delay as compared to the clock signal CK. The clock CK0 is provided to the strobe routing circuit 620 so that the strobe signals are properly timed to result in proper data alignment. The regenerated clock signal CKM is provided to the respective set of memory devices so that the respective data buffer 118 and the respective set of memory devices are locally synchronized.

We claim:

1. A memory module operable to communicate with a memory controller via a memory bus, the memory bus including signal lines, the signal lines including a set of control/address signal lines and a plurality of sets of data/strobe signal lines, the memory module comprising:

- a module board having edge connections for coupling to respective signal lines in the memory bus;
- a module control device mounted on the module board and configured to receive system command signals for memory operations via the set of control/address signal lines and to output module command signals and module control signals in response to the system command signals, the module control device being further configured to receive a system clock signal and output a module clock signal; and

memory devices mounted on the module board and configured to receive the module command signals and the module clock signal, and to perform the memory operations in response to the module command signals, the memory devices including a plurality of sets of memory devices corresponding to respective sets of the plurality of sets of data/strobe signal lines; and

a plurality of buffer circuits corresponding to respective sets of the plurality of sets of data/strobe signal lines, wherein each respective buffer circuit of the plurality of buffer circuits is mounted on the module board, coupled between a respective set of data/strobe signal lines and a respective set of memory devices, and configured to receive the module control signals and the module clock signal, the each respective buffer circuit including a data path corresponding to each data signal line in the respective set of data/strobe signal lines, and a command processing circuit configured to decode the module control signals and to control the data path in accordance with the module control signals and the module clock signal, wherein the data path corresponding to the each data signal line includes at least one tristate buffer controlled by the command processing circuit and a delay circuit configured to delay a signal through the data path by an amount determined by the command processing circuit in response to at least one of the module control signals.

2. The memory module of claim 1, wherein the memory operations include a first memory operation and a second memory operation subsequent to the first memory operation, wherein the command signals include a first set of command signals for the first memory operation and a second set of command signals for the second memory operation, wherein the module control signals include a first set of module control signals output by the module control device in response to the first set of command signals and a second set of module control signals output by the module control device in response to the second set of command signals,

wherein the at least one of the module control signals include at least one of the first set of module control signals, and wherein the signal through the data path is a signal associated with the second memory operation.

3. The memory module of claim 2, wherein the memory devices are arranged in a plurality of ranks and the respective set of memory devices include at least one memory device from each of the plurality of ranks, wherein the module command signals include a first set of module command signals output by the module control device in response to the first set of command signals and a second set of module command signals output by the module control device in response to the second set of command signals, and wherein the second set of module command signals include chip select signals that select the at least one memory device in the respective set of memory devices from one of the plurality of ranks to perform the second memory operation.

4. The memory module of claim 1, wherein each of the plurality of buffer circuits has a data width of 1 byte, and wherein each of the memory devices has a data width of 1 byte.

5. The memory module of claim 1, wherein each of the plurality of buffer circuits has a data width of 1 byte, and wherein each of the memory devices has a data width of 4 bits.

6. The memory module of claim 1, wherein the each respective buffer circuit further includes a receiver circuit for each of the module control signals, the receiver circuit including a metastability detection circuit configured to determine a metastability condition in the each of the module control signals with respect to the module clock signal.

7. The memory module of claim 6, wherein each of the plurality of buffer circuits has a data width of 1 byte, and wherein each of the memory devices has a data width of 1 byte.

8. The memory module of claim 6, wherein each of the plurality of buffer circuits has a data width of 1 byte, and wherein each of the memory devices has a data width of 4 bits.

9. The memory module of claim 1, wherein the each respective buffer circuit further includes a clock regeneration circuit configured to generate a local clock signal having a programmable phase relationship with the module clock signal, wherein the each respective buffer circuit is further configured to output the local clock signal to the respective set of memory devices.

10. The memory module of claim 9, wherein the each respective buffer circuit includes a first data path for transmitting a strobe signal associated with the second memory operation and a second data path for transmitting a first data signal associated with the second memory operation, the first data path including a sampler that samples the strobe signal in accordance with the local clock signal, and the second data path including a sampler that samples the first data signal in accordance with the sampled strobe signal.

11. The memory module of claim 10, wherein each of the plurality of buffer circuits has a data width of 1 byte, and wherein each of the memory devices has a data width of 1 byte.

12. The memory module of claim 10, wherein each of the plurality of buffer circuits has a data width of 1 byte, and wherein each of the memory devices has a data width of 4 bits.

* * * * *