



US011268776B1

(12) **United States Patent**
Noonan

(10) **Patent No.:** **US 11,268,776 B1**
(45) **Date of Patent:** **Mar. 8, 2022**

- (54) **EXPANSION CHAMBER ASSEMBLY AND A METHOD OF MANUFACTURING THE SAME**
- (71) Applicant: **F.M. Products Inc**, Boise, ID (US)
- (72) Inventor: **Paul T. Noonan**, Boise, ID (US)
- (73) Assignee: **F.M. Products Inc**, Boise, ID (US)
- (*) Notice: Subject to any disclaimer, the term of this patent is extended or adjusted under 35 U.S.C. 154(b) by 0 days.
- (21) Appl. No.: **15/987,833**
- (22) Filed: **May 23, 2018**

Related U.S. Application Data

- (60) Provisional application No. 62/510,707, filed on May 24, 2017.
- (51) **Int. Cl.**
F41A 21/30 (2006.01)
F41A 21/28 (2006.01)
- (52) **U.S. Cl.**
CPC *F41A 21/30* (2013.01); *F41A 21/28* (2013.01)
- (58) **Field of Classification Search**
CPC *F41A 21/30*; *F41A 21/28*
USPC 89/14.4
See application file for complete search history.

(56) **References Cited**

U.S. PATENT DOCUMENTS

- 4,307,652 A * 12/1981 Witt *F41A 21/36*
89/14.3
- 8,025,003 B1 * 9/2011 Saur *F41A 21/24*
89/14.05

- 8,261,651 B2 * 9/2012 Casas Salva *F41G 1/02*
89/14.4
- 8,939,057 B1 * 1/2015 Edsall *F41A 21/30*
181/223
- 8,997,621 B1 * 4/2015 Dater *F41A 21/325*
89/14.3
- 9,102,010 B2 * 8/2015 Wilson *F41A 21/30*
- 9,500,427 B1 * 11/2016 Larue *F41A 21/30*
- 9,658,010 B1 * 5/2017 Oglesby *F41A 13/12*
- 9,677,839 B1 * 6/2017 Phoenix *F41A 21/30*
- 9,982,959 B2 * 5/2018 Washburn, III *F41A 21/30*
- 10,107,581 B2 * 10/2018 Garst *F41A 21/30*
- 10,126,084 B1 * 11/2018 Oglesby *F41A 21/30*
- 10,234,230 B1 * 3/2019 Oglesby *F41A 21/325*
- 10,337,819 B1 * 7/2019 Stark *F41A 21/30*
- 10,502,513 B2 * 12/2019 Ellison *F41A 21/30*
- 2003/0010187 A1 * 1/2003 Muirhead *F41A 21/24*
89/14.1
- 2003/0145718 A1 * 8/2003 Hausken *F41A 21/30*
89/14.4
- 2011/0186377 A1 * 8/2011 Kline *F41A 21/30*
181/223
- 2012/0011757 A1 * 1/2012 Yost *F41A 21/40*
42/79
- 2012/0152649 A1 * 6/2012 Larue *F41A 21/30*
181/223

(Continued)

Primary Examiner — Michelle Clement

(57) **ABSTRACT**

A expansion chamber assembly for a firearm is disclosed. The expansion chamber contains an outer tube containing a front end and a rear end, a front cap coupled with the outer tube at the front end, a rear cap coupled with the outer tube at the rear end, an inner tube retained within the outer tube by the front cap and the rear cap, wherein the inner cap contains one or more through apertures to allow expanding gasses to move from the inner tube into the outer tube, and one or more exit apertures to allow expending gases to exit the expansion chamber assembly.

10 Claims, 29 Drawing Sheets

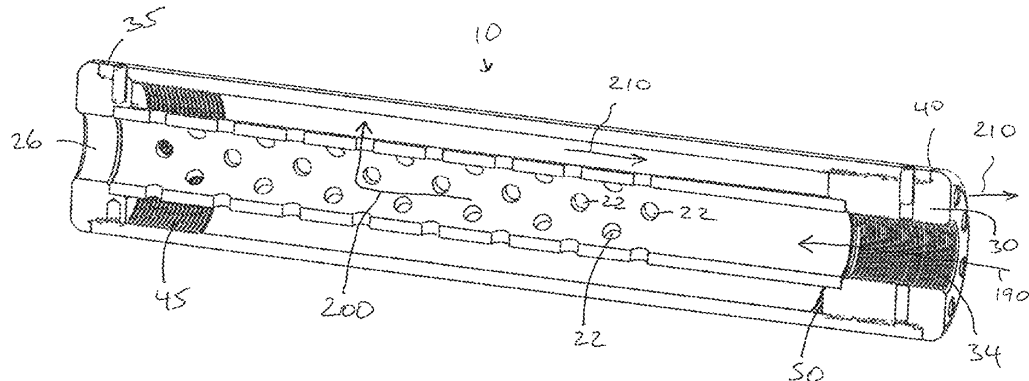

(56)	References Cited					
	U.S. PATENT DOCUMENTS					
2013/0180797	A1 *	7/2013	Dueck	F41A 21/34	2015/0377577 A1 * 12/2015 Pappas
					181/223 F41A 21/34
2013/0319790	A1 *	12/2013	Bladen	F41A 21/30	89/14.2
					181/223	2016/0010935 A1 * 1/2016 Clarke
2014/0059913	A1 *	3/2014	Diamond	F41C 27/00 F41A 21/34
					42/90	89/14.4
2014/0224574	A1 *	8/2014	Latka	F41A 21/30	2016/0018179 A1 * 1/2016 Morris
					181/223 F41A 21/30
2014/0231168	A1 *	8/2014	Dueck	F41A 21/34	181/223
					181/223	2016/0054086 A1 * 2/2016 Westlake
2014/0262605	A1 *	9/2014	Washburn, III	F41A 21/30 F41A 21/30
					181/223	89/14.4
2015/0001001	A1 *	1/2015	Wilson	F41A 21/30	2016/0061551 A1 * 3/2016 Petersen
					181/223 F41A 21/28
2015/0090105	A1 *	4/2015	Pace	F41A 21/30	89/14.4
					89/14.4	2016/0123689 A1 * 5/2016 Maeda
2015/0136519	A1 *	5/2015	Moore	F41A 21/30 F41A 21/30
					181/223	89/14.3
2015/0241159	A1 *	8/2015	Michal	F41A 21/30	2016/0161203 A1 * 6/2016 Wilson
					89/14.4 F41A 21/30
2015/0260472	A1 *	9/2015	Smith	F41A 21/30	2016/0209149 A1 * 7/2016 Fischer
					89/14.2 F41A 21/30
2015/0285575	A1 *	10/2015	Selafani	F41A 21/30	2017/0199002 A1 * 7/2017 Hwang
					181/223 F41A 21/325
2015/0308776	A1 *	10/2015	Smith	F41A 21/34	2018/0031346 A1 * 2/2018 Washburn, III
					89/14.2 F41A 21/30
2015/0354422	A1 *	12/2015	Liskey	F41A 21/30	2018/0038663 A1 * 2/2018 Larue
					89/14.4 F41A 3/66
						2018/0058789 A1 * 3/2018 Dorne
					 F41A 21/30
						2018/0252489 A1 * 9/2018 Parker
					 F41A 21/30
						2018/0321008 A1 * 11/2018 Barney
					 F41A 21/30
						2019/0017767 A1 * 1/2019 Griffis
					 F41A 21/30
						2019/0017768 A1 * 1/2019 Thomas
					 F41A 21/30
						2019/0033030 A1 * 1/2019 Belykov
					 F41A 21/30
						2020/0072571 A1 * 3/2020 Washburn, III
					 F41A 21/30
						2020/0141679 A1 * 5/2020 Garst
					 F41A 21/30
						2020/0166304 A1 * 5/2020 Martin
					 F41A 21/28
						2020/0173751 A1 * 6/2020 Dorne
					 F41A 21/30
						2020/0232740 A1 * 7/2020 Honigmann
					 F41A 21/30

* cited by examiner

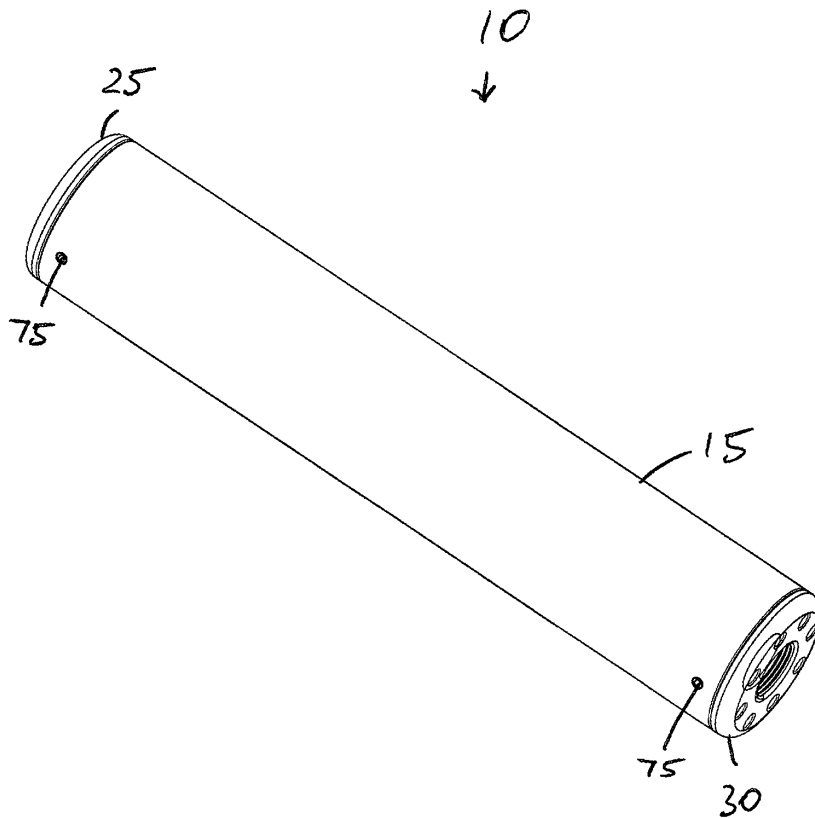

Figure 1a

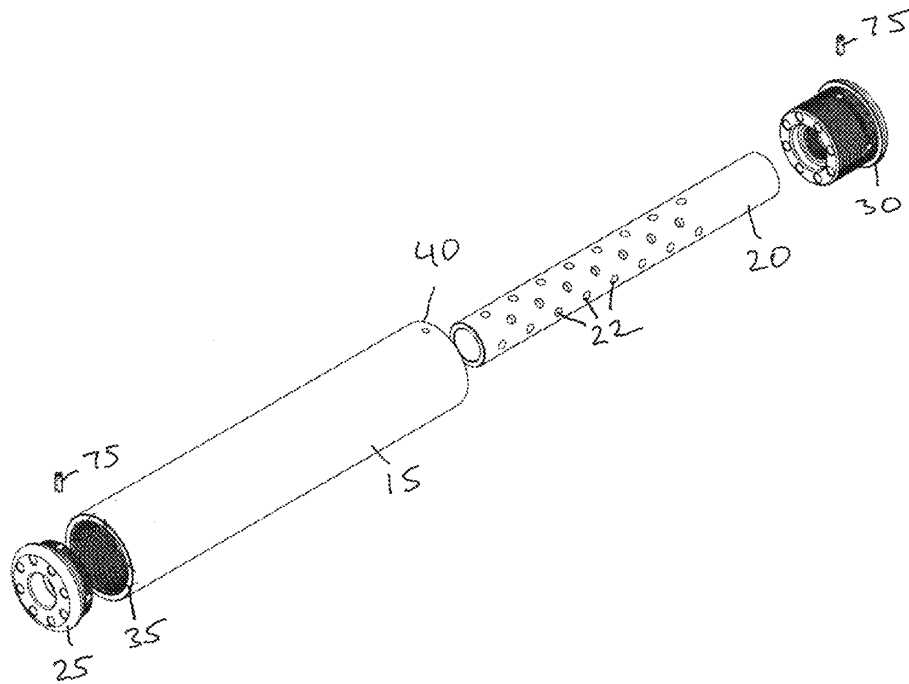

Figure 1b

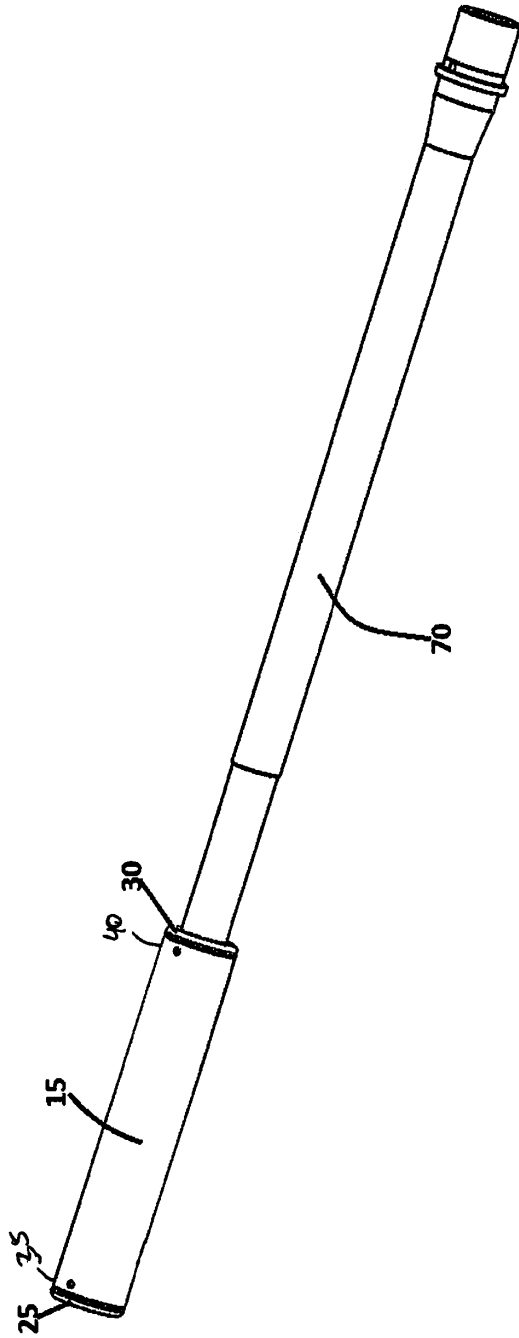

Figure 2

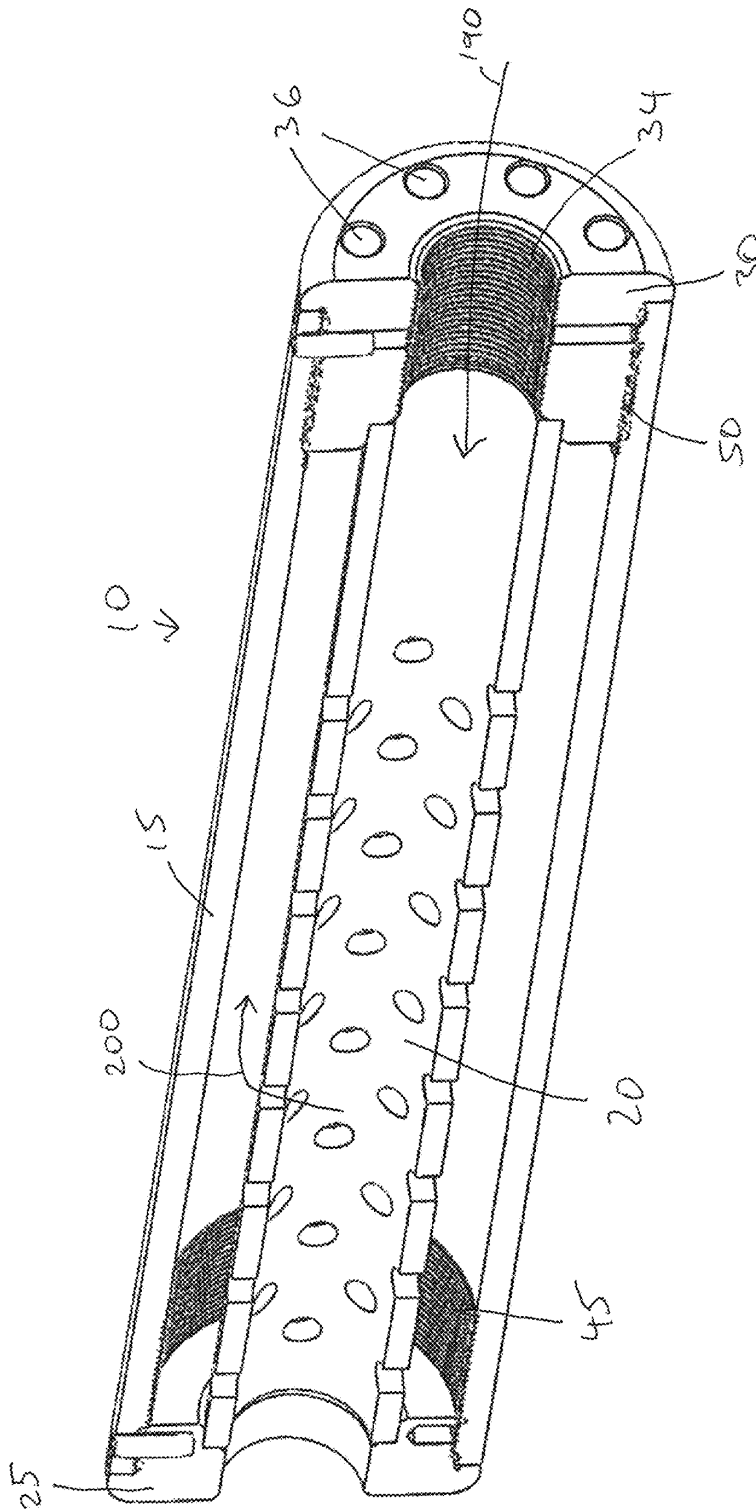

Figure 3b

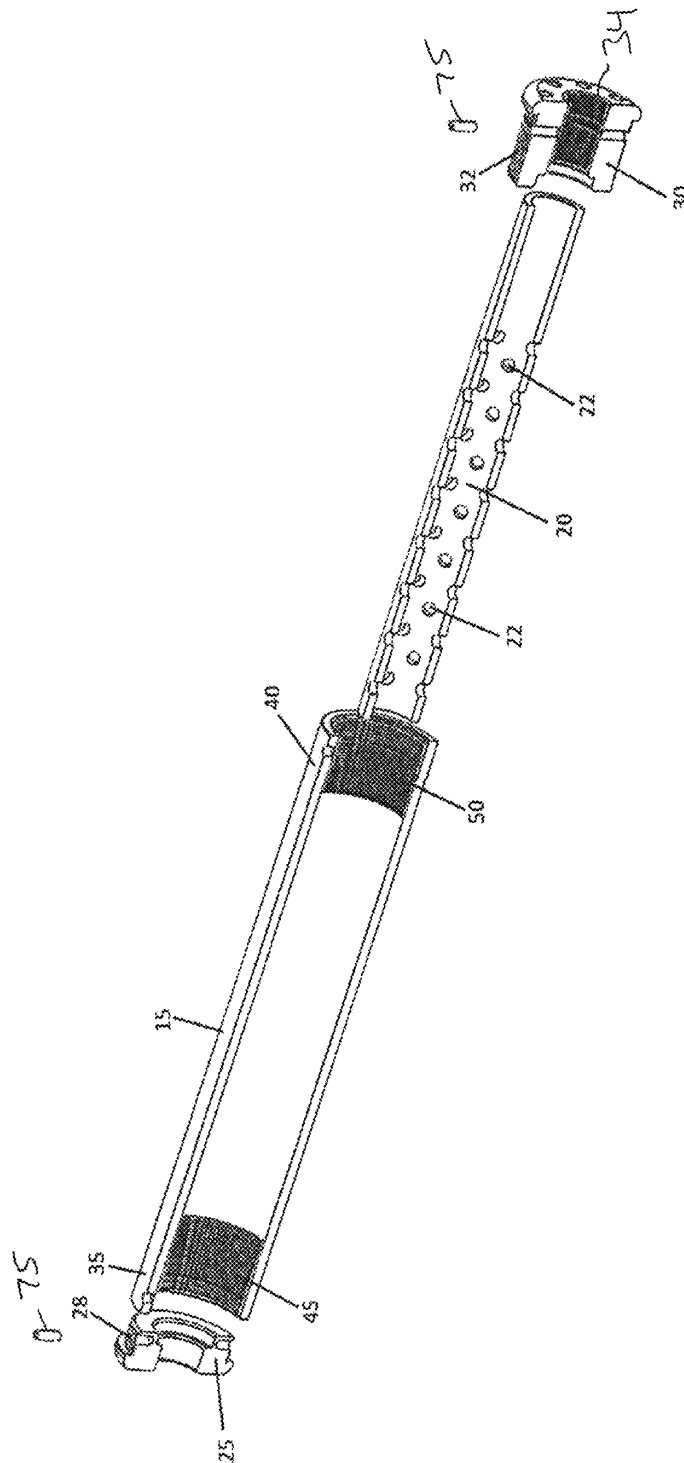

Figure 3c

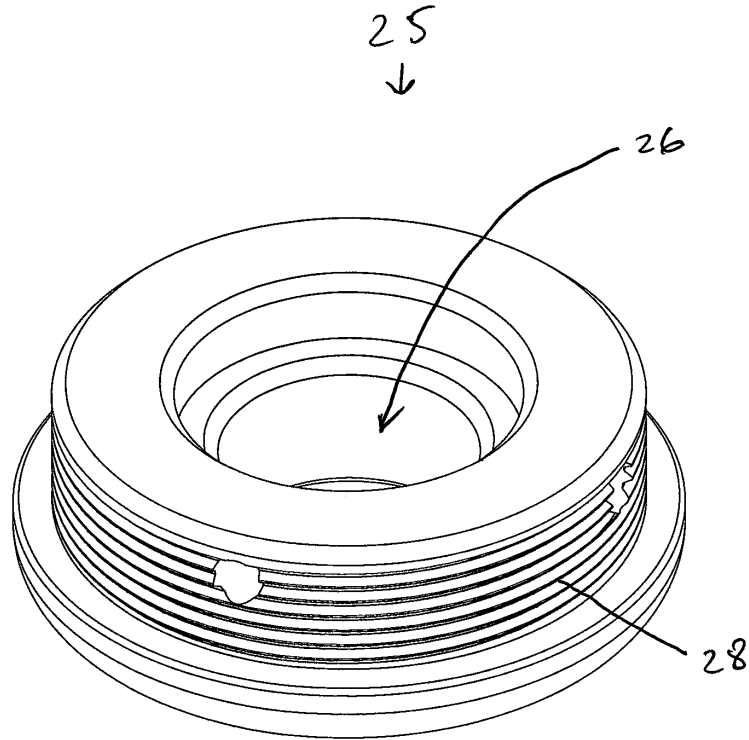

Figure 4a

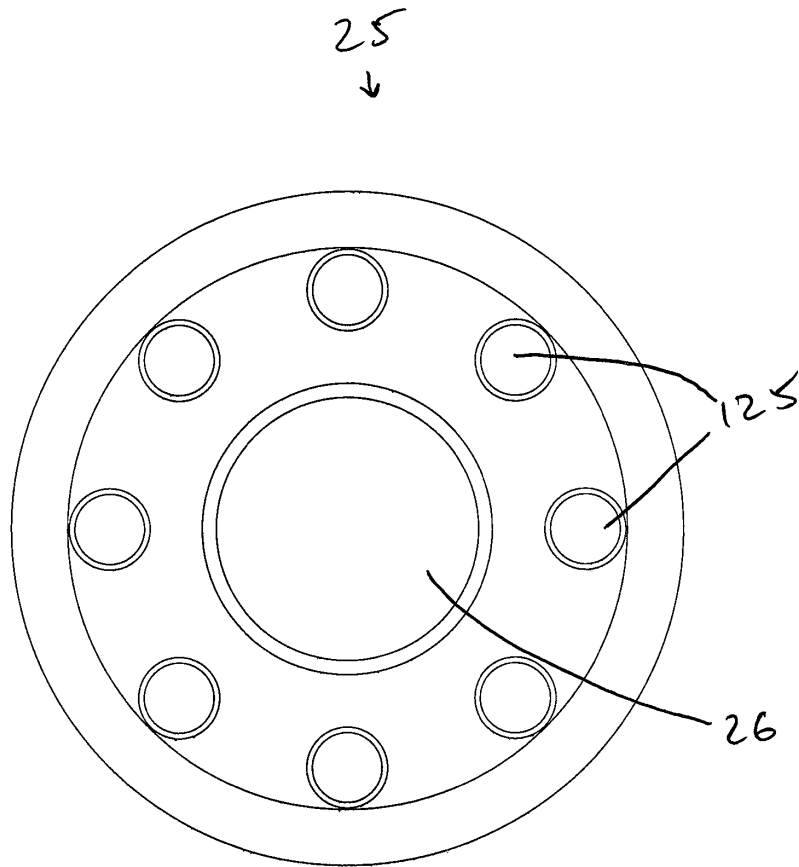

Figure 4b

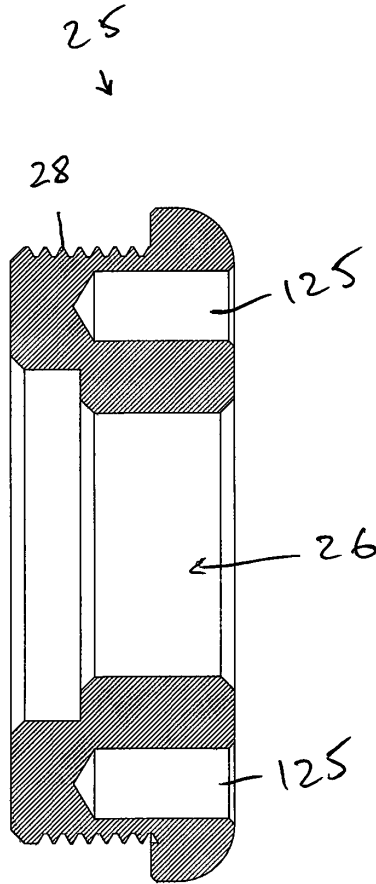

Figure 4c

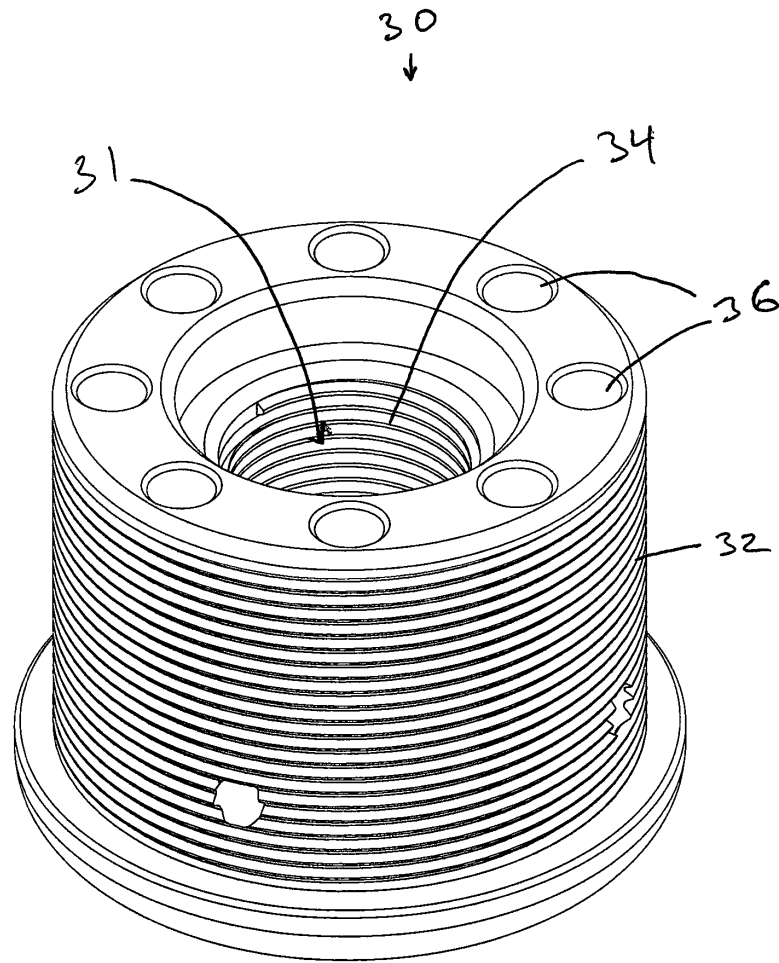

Figure 5a

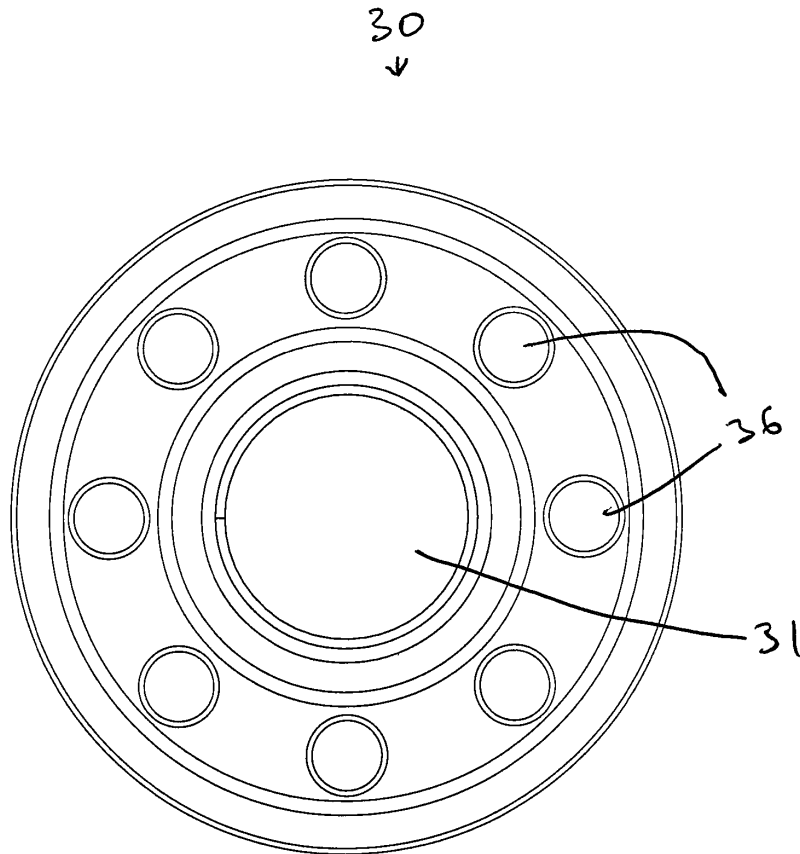

Figure 5b

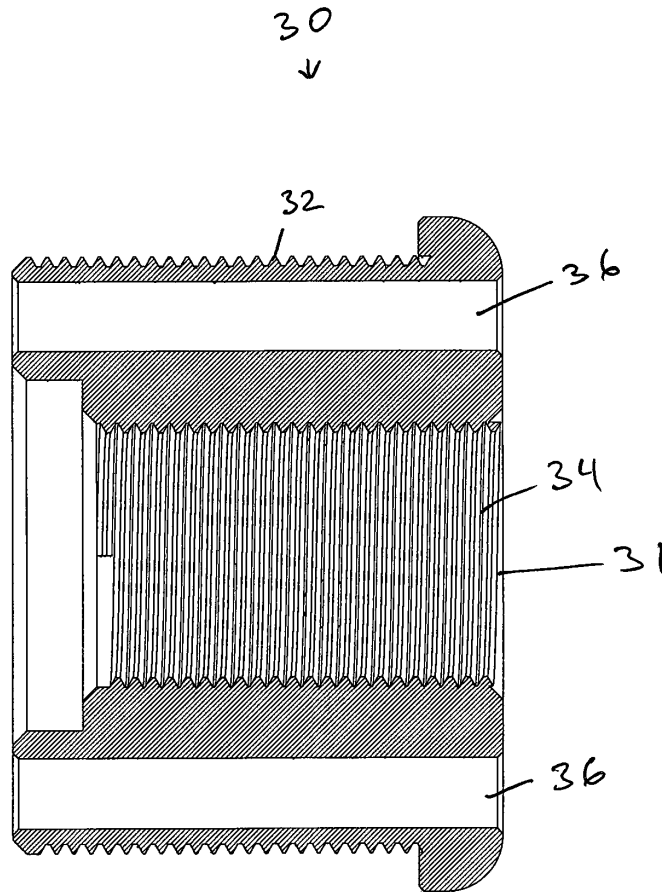

Figure 5c

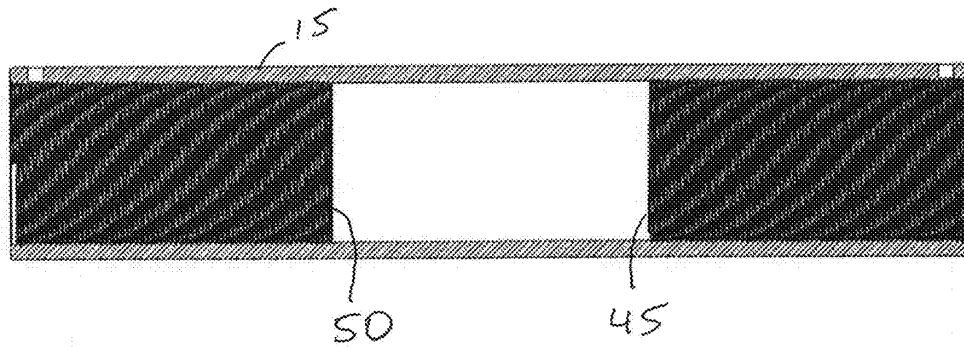

Figure 6a

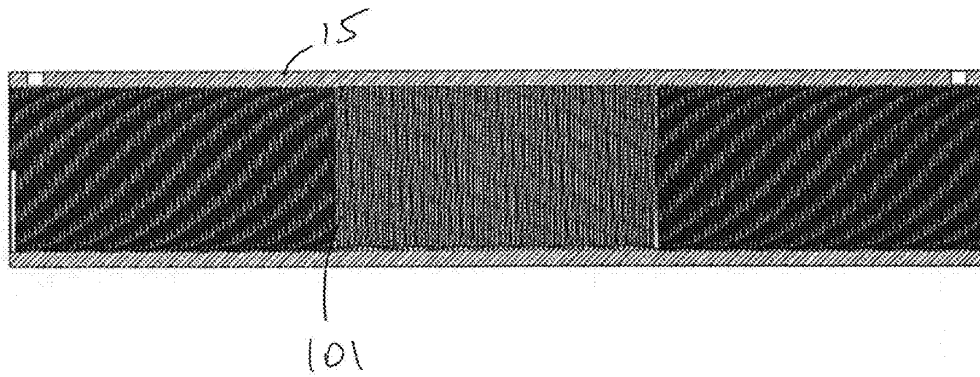

Figure 6b

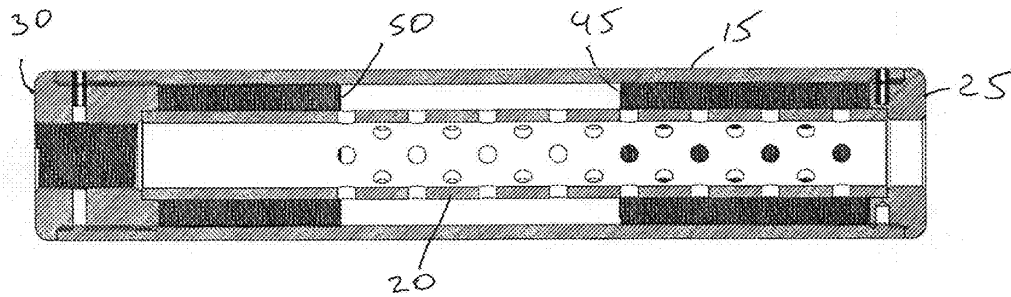

Figure 7a

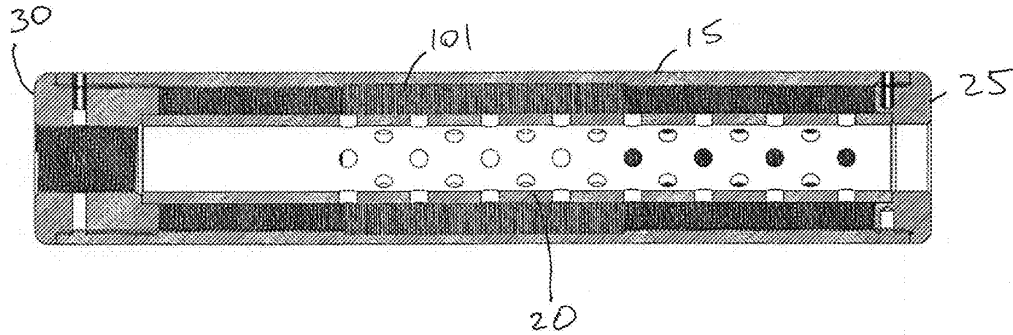

Figure 7b

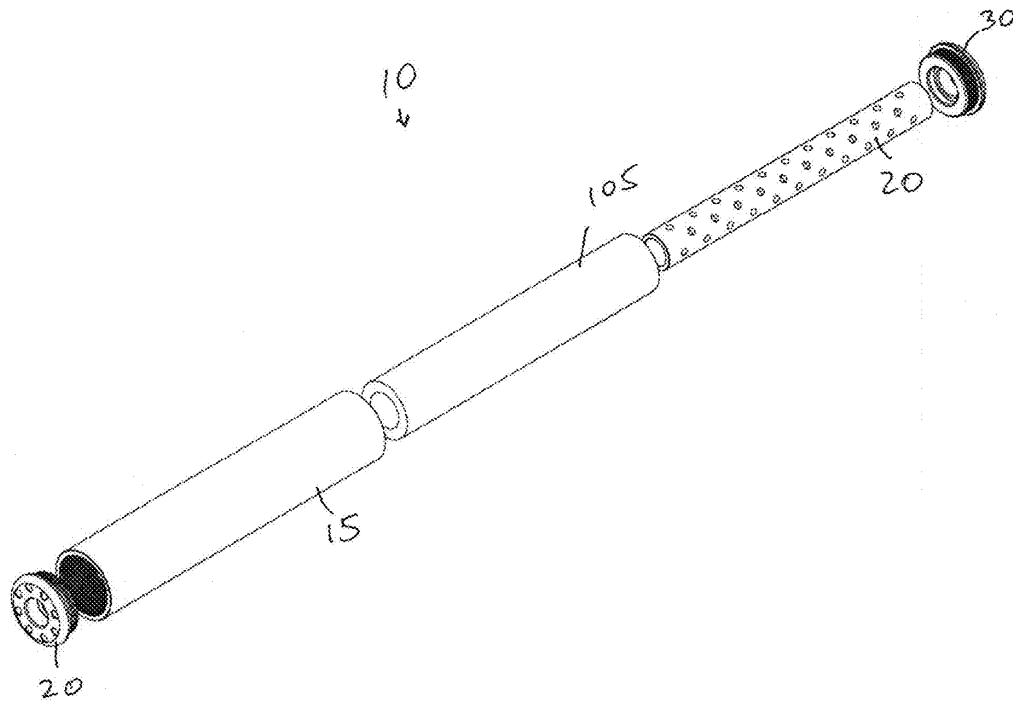

Figure 8a

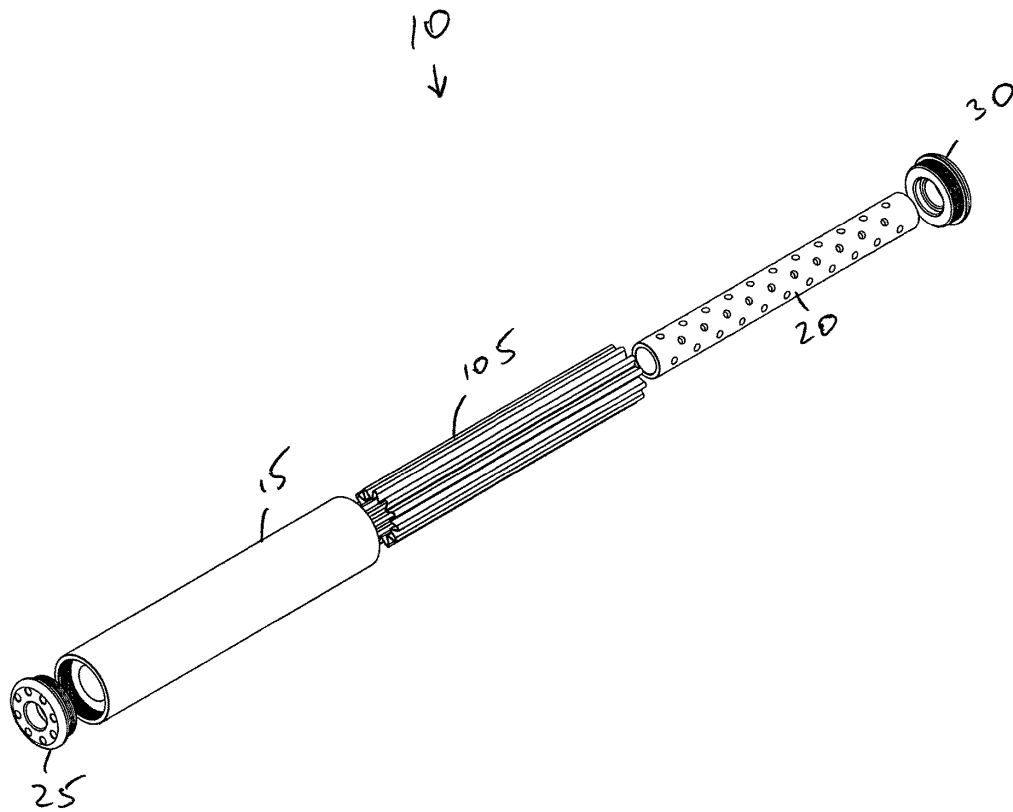

Figure 8b

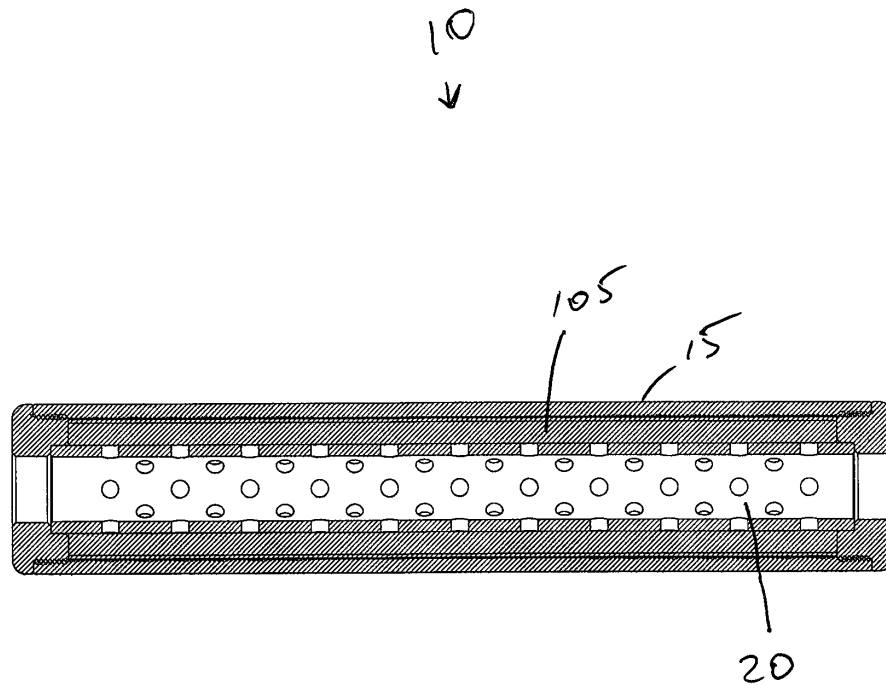

Figure 9

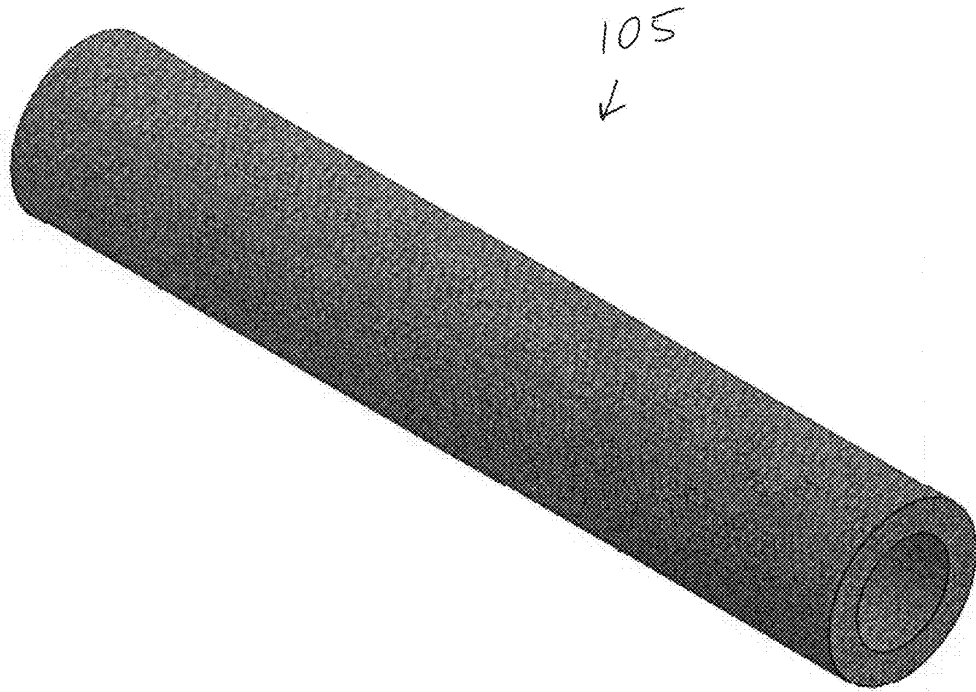

Figure 10a

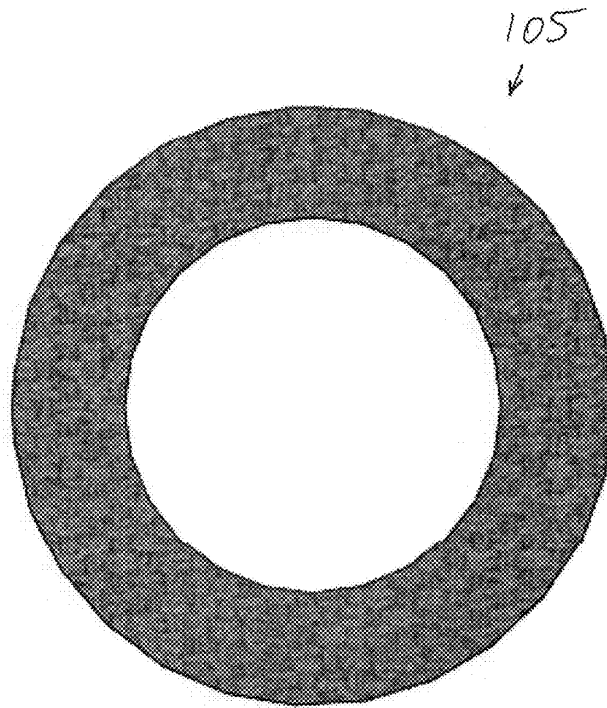

Figure 10b

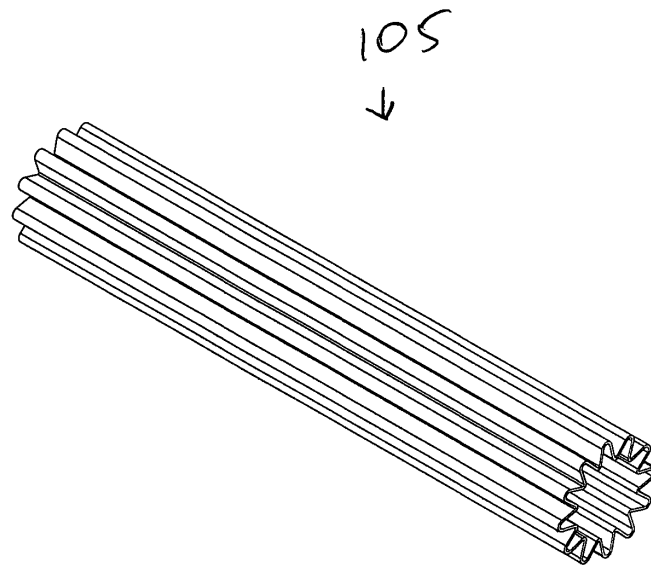

Figure 11a

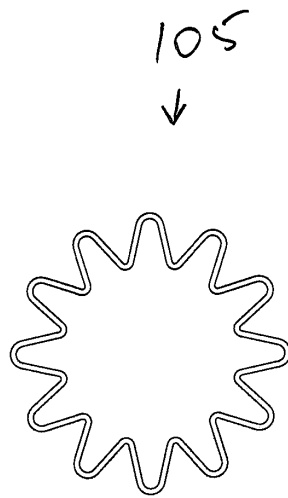

Figure 11b

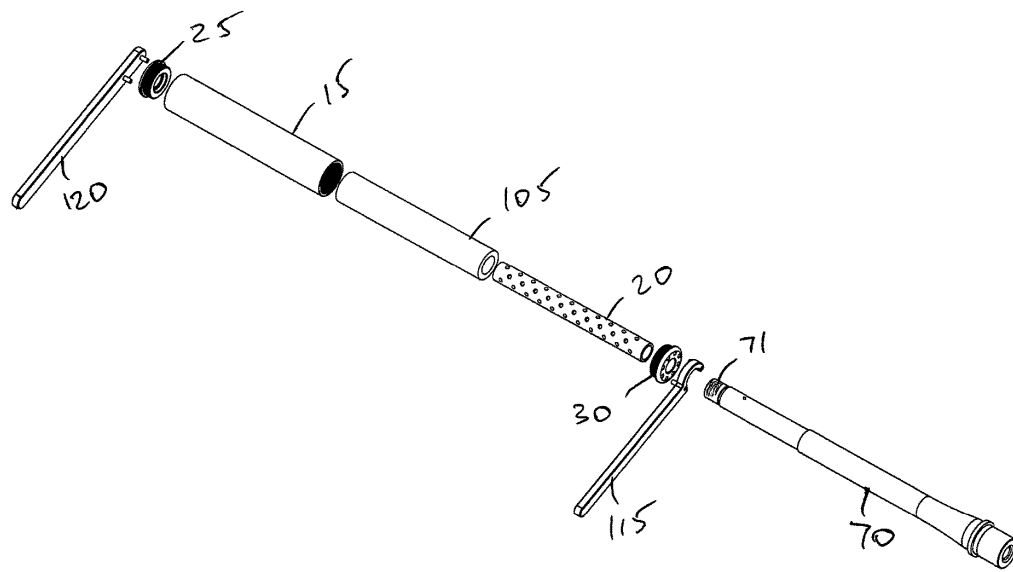

Figure 12 a

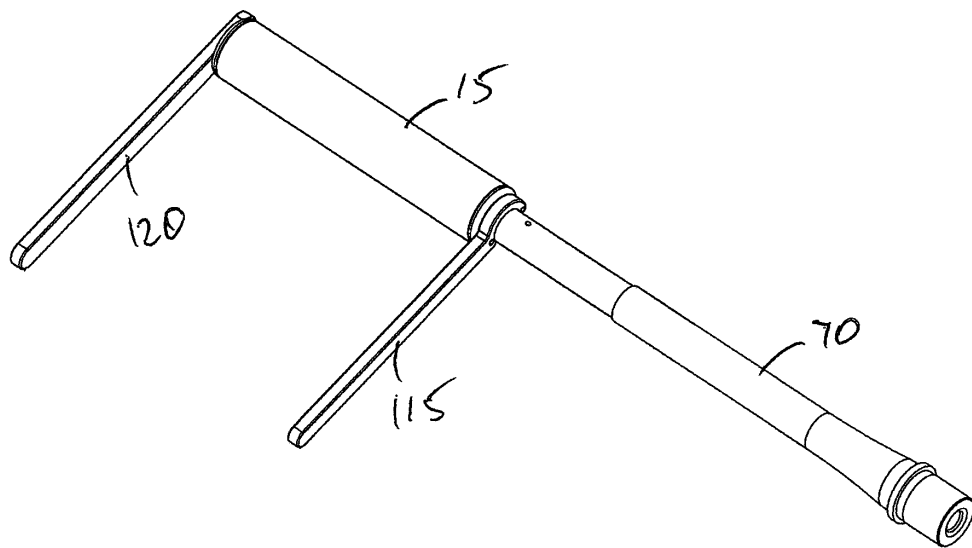

Figure 12 B

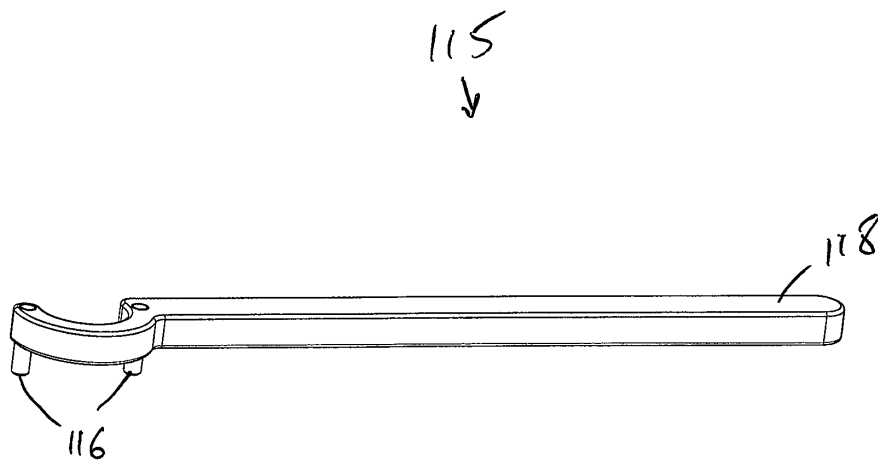

Figure 13a

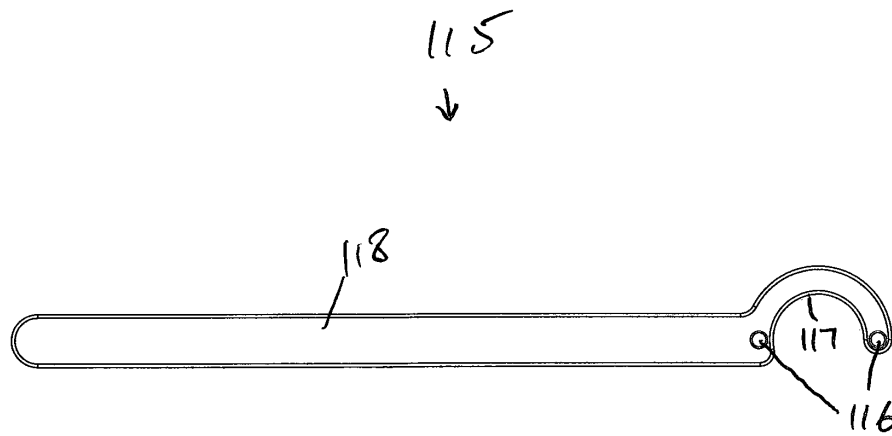

Figure 13b

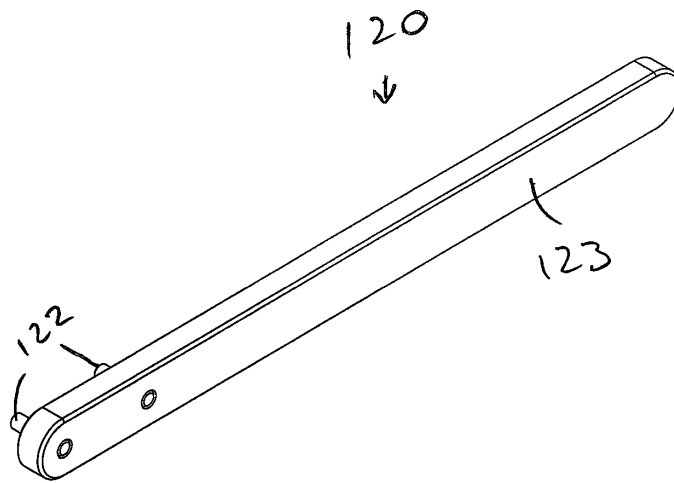

Figure 14a

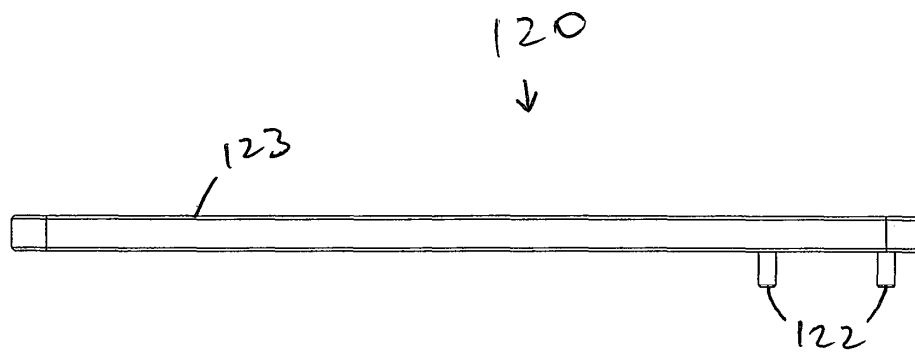

Figure 14B

EXPANSION CHAMBER ASSEMBLY AND A METHOD OF MANUFACTURING THE SAME

CROSS REFERENCE TO RELATED APPLICATIONS

This application claims the benefit of U.S. Provisional Application No. 62/510,707, filed on May 24, 2017, which is incorporated herein by reference in its entirety.

FIELD

The present invention relates to a firearm. More particularly, the present invention relates to an expansion chamber assembly for a firearm.

BACKGROUND

Firing a bullet from a firearm creates a loud noise. The firearm silencers known in the art have various baffles and intermediate spacers that attempt to decrease the noise level created by the firearm when firing a bullet. These silencers are heavy, use lots of different types of parts and/or are difficult to assemble thereby making them expensive to manufacture and quite costly for ultimate consumers. In addition, many prior art silencers do not significantly reduce muzzle flash and/or recoil generated by the firearm when firing the bullet. Therefore, a need exists for a way to reduce noise levels, flash and/or recoil when firing a firearm.

BRIEF DESCRIPTION OF THE FIGURES

FIG. 1*a* depicts expansion chamber assembly according to some embodiments presently disclosed.
 FIG. 1*b* depicts an exploded view of the expansion chamber assembly shown in FIG. 1*a*.
 FIG. 2 depicts the expansion chamber assembly shown in FIG. 1*a* coupled with a barrel of a firearm.
 FIG. 3*a* depicts a cut away view of the expansion chamber assembly shown in FIG. 1*a*.
 FIG. 3*b* depicts another cut away view of the expansion chamber assembly shown in FIG. 1*a*.
 FIG. 3*c* depicts a cut away, exploded view of the expansion chamber assembly shown in FIG. 1*a*.
 FIG. 4*a* depicts a perspective view of the front cap according to some embodiments presently disclosed.
 FIG. 4*b* depicts a top view of the front cap shown in FIG. 4*a*.
 FIG. 4*c* depicts a side, cut away view of the front cap shown in FIG. 4*a*.
 FIG. 5*a* depicts a perspective view of the rear cap according to some embodiments presently disclosed.
 FIG. 5*b* depicts a top view of the rear cap shown in FIG. 5*a*.
 FIG. 5*c* depicts a side, cut away view of the rear cap shown in FIG. 5*a*.
 FIG. 6*a* depicts a side, cut away view of the outer tube according to some embodiments presently disclosed.
 FIG. 6*b* depicts another side, cut away view of the outer tube according to some embodiments presently disclosed.
 FIG. 7*a* depicts a side, cut away view of the expansion chamber assembly according to some embodiments presently disclosed.
 FIG. 7*b* depicts another side, cut away view of the expansion chamber assembly according to some embodiments presently disclosed.

FIG. 8*a* depicts an exploded view of the expansion chamber assembly according to some embodiments presently disclosed.
 FIG. 8*b* depicts another exploded view of the expansion chamber assembly according to some embodiments presently disclosed.
 FIG. 9 depicts a side, cut away view of the expansion chamber assembly according to some embodiments presently disclosed.
 FIG. 10*a* depicts a perspective view of a sound absorbing material according to some embodiments presently disclosed.
 FIG. 10*b* depicts a front view of the sound absorbing material shown in FIG. 10*a*.
 FIG. 11*a* depicts a perspective view of another sound absorbing material according to some embodiments presently disclosed.
 FIG. 11*b* depicts a front view of the sound absorbing material shown in FIG. 11*a*.
 FIG. 12*a* depicts an exploded view of the expansion chamber assembly according to some embodiments presently disclosed.
 FIG. 12*b* depicts an assembled view of the expansion chamber shown in FIG. 12*a*.
 FIG. 13*a* depicts a perspective view of a tool according to some embodiments presently disclosed.
 FIG. 13*b* depicts a top view of the tool shown in FIG. 13*a*.
 FIG. 14*a* depicts a perspective view of another tool according to some embodiments presently disclosed.
 FIG. 14*b* depicts a side view of the tool shown in FIG. 14*a*.

In the following description, like reference numbers are used to identify like elements. Furthermore, the drawings are intended to illustrate major features of exemplary embodiments in a diagrammatic manner. The drawings are not intended to depict every feature of every implementation nor relative dimensions of the depicted elements, and are not drawn to scale.

DETAILED DESCRIPTION

In the following description, like reference numbers are used to identify like elements. Furthermore, the drawings are intended to illustrate major features of exemplary embodiments in a diagrammatic manner. The drawings are not intended to depict every feature of every implementation nor relative dimensions of the depicted elements, and are not drawn to scale.

In the following description, numerous specific details are set forth to clearly describe various specific embodiments disclosed herein. One skilled in the art, however, will understand that the presently claimed invention may be practiced without all of the specific details discussed below. In other instances, well known features have not been described so as not to obscure the invention.

Referring to FIGS. 1*a-b*, an expansion chamber assembly 10 is shown according to some embodiments presently disclosed. According to some embodiments, the expansion chamber assembly 10 comprises an outer tube 15, an inner tube 20, a front cap 25, and a rear cap 30. According to some embodiments, the expansion chamber assembly 10 is coupled with an exit end of a barrel 70 (shown in FIG. 2) from a firearm. Although the barrel 70 is shown as a rifle barrel, it is to be understood that the expansion chamber assembly 10 can be coupled with a rifle barrel or a handgun barrel. It is to be further understood that the expansion chamber assembly 10 is removably coupled with the barrel

3

70 or the expansion chamber assembly 10 integral with the barrel 70. According to some embodiments, the expansion chamber assembly 10 is welded with the exit end of the barrel 70. According to some embodiments, the expansion chamber assembly 10 may be pinned with the exit end of the barrel 70.

According to some embodiments, the outer tube 15 comprises a first diameter and the inner tube 20 comprises a second diameter, wherein the first diameter is larger than the second diameter. According to some embodiments, the outer tube 15 has a diameter sufficient to accommodate the inner tube 20. According to some embodiments, the outer tube 15 and the inner tube 20 are hollow cylinders wherein the outer tube 15 has a diameter sufficient to accommodate the inner tube 20.

According to some embodiments, the inner tube 20 is retained inside the outer tube 15 with the front cap 25 and the rear cap 30 as shown in FIGS. 3a-b. According to some embodiments, the front cap 25 and/or the rear cap 30 are coupled with the outer tube 15. According to some embodiments, the front cap 25 and/or the rear cap 30 are removably coupled with the outer tube 15. According to some embodiments, the front cap 25 and/or the rear cap 30 are welded with the outer tube 15. According to some embodiments, the front cap 25 and/or the rear cap 30 are coupled with the outer tube 15 by one or more fasteners 75. According to some embodiments, the fasteners 75 are a pin, a screw, a set screw, a full dog point set screw, or a dogleg set screw.

According to some embodiments, the front cap 25 comprises a through aperture 26 (as shown in FIGS. 4a-c) and an outer thread 28 (as shown in FIGS. 4a and 4c). According to some embodiments, the rear cap 30 comprises a through aperture 31 (as shown in FIGS. 5a-c) and an outer thread 32 (as shown in FIGS. 5a and 5c). According to some embodiments, the outer tube 15 comprises a front end 35 and a rear end 40 (shown in FIG. 1b). The front end 35 may comprise an inner screw threads 45 (shown in cutaway FIGS. 3a-c) configured to accommodate and/or engage the outer thread 28 of the front cap 25. The rear end 40 may comprise an inner screw threads 50 (shown in cutaway FIGS. 3a-c) configured to accommodate and/or engage the outer thread 32 of the rear cap 30. According to some embodiments, the inner tube 20 is retained inside the outer tube 15 by screwing the front cap 25 in the front end 35 and screwing the rear cap 30 in the rear end 40. According to some embodiments, the inner tube 20 is sandwiched inside the outer tube 15 between the front cap 25 and the rear cap 30.

According to some embodiments, the front cap 25 comprises a through aperture 26 (as shown in FIGS. 4a-c) with an inner thread (not shown). According to some embodiments, the rear cap 30 comprises a through aperture 31 (as shown in FIGS. 5a-c) with an inner thread (not shown). According to some embodiments, the outer tube 15 comprises a front end 35 and a rear end 40 (shown in FIG. 1b). The front end 35 may comprise an outer screw threads (not shown) configured to accommodate and/or engage the inner thread of the front cap 25. The rear end 40 may comprise an outer screw threads (not shown) configured to accommodate and/or engage the inner thread of the rear cap 30. According to some embodiments, the inner tube 20 is sandwiched inside the outer tube 15 between the front cap 25 and the rear cap 30.

According to some embodiments, at least a portion of the through aperture 31 of the rear cap 30 comprises an inner thread 34 (shown in FIGS. 5a and 5c) configured to accommodate and/or engage at least a portion of an outer thread 71 (shown in FIG. 12a) on the exit end of the barrel 70.

4

According to some embodiments, the entire through aperture 31 of the rear cap 30 comprises an inner thread 34 (shown in FIGS. 5a and 5c) configured to accommodate at least a portion of an outer thread 71 (shown in FIG. 12a) on the exit end of the barrel 70.

According to some embodiments, a bullet, fired from a firearm, travels through the firearm's barrel 70, through the aperture 31, through the inner tube 20, and through the aperture 26 of the expansion chamber assembly 10. Similar to the bullet, the expanding gasses formed by the firing of the bullet also travel through the firearm's barrel 70 and into the expansion chamber assembly 10 as shown by arrow 190 in FIGS. 3a-b.

According to some embodiments, at least a portion of the expanding gasses exit with the bullet through the aperture 26 of the front cap 25 of the expansion chamber assembly 10. According to some embodiments, the inner tube 20 comprises one or more through apertures 22 to allow at least another portion of the expanding gasses to enter the outer tube 15 as shown by the arrow 200 in FIGS. 3a-b. According to some embodiments, the through apertures 22 are round, rectangular, oval, circular or any other geometric shape.

According to some embodiments, the expanding gasses located between the outer tube 15 and the inner tube 20 may exit the expansion chamber assembly 10 through one or more exit through apertures (not shown) in the outer tube 15. According to some embodiments, the expanding gasses located between the outer tube 15 and the inner tube 20 may exit the expansion chamber assembly 10 through one or more exit through apertures 36 in the rear cap 30 as shown by arrow 210 in FIG. 3a. According to some embodiments, the expanding gasses located between the outer tube 15 and the inner tube 20 may exit the expansion chamber assembly 10 through one or more exit apertures (not shown) in the front cap 25. According to some embodiments, one or more exit through apertures 36 are in communication with the space between the outer tube 15 and the inner tube 20.

According to some embodiments, the inner screw threads 45 extend into the outer tube 15 (as shown in FIGS. 6a and 7a) and are positioned to interact with the expanding gasses located between the outer tube 15 and the inner tube 20. According to some embodiments, the inner screw threads 50 extend into the outer tube 15 (as shown in FIGS. 6a and 7a) and are positioned to interact with the expanding gasses located between the outer tube 15 and the inner tube 20. According to some embodiments, the inner screw threads 45 and the inner screw thread 50 are the same inner screw thread 101 that spans the entire length of the outer tube 15 (as shown in FIGS. 6b and 7b) and positioned to interact with the expanding gasses located between the outer tube 15 and the inner tube 20. According to some embodiments, the inner screw threads 45, the inner screw threads 50 and/or the inner screw threads 101 are positioned to interact with the expanding gasses located between the outer tube 15 and the inner tube 20 and configured to minimize the sound generated by the bullet fired from the firearm.

According to some embodiments, the expansion chamber assembly 10 reduces recoil of the firearm by allowing a portion of the expanding gasses to exit through the apertures 36 located in the rear cap 30. According to some embodiments, the expansion chamber assembly 10 reduces recoil of the firearm by allowing a portion of the expanding gasses to exit the expansion chamber assembly 10 in a direction opposite a direction of travel of the bullet being fired from the firearm.

According to some embodiments, the through apertures 36 are 0.125 inches in diameter. According to some embodi-

5

ments, the through apertures 36 are round, rectangular, oval, circular or any other geometric shape. According to some embodiments, the rear cap 30 comprises eight (8) through apertures 36. According to some embodiments, the rear cap 30 comprises eight (8) through apertures 36 evenly spaced around the perimeter of the rear cap 30. According to some embodiments, the through apertures 36 are evenly spaced around the perimeter of the rear cap 30.

According to some embodiments presently disclosed, the expansion chamber assembly 10 is configured to decelerate and cool at least a portion of the expanding gasses thereby reducing the noise and/or flash created when the bullet is fired from the firearm.

According to some embodiments presently disclosed, the expansion chamber assembly 10 comprises one or more sound absorbing materials 105 (as shown in FIGS. 8a-b) configured to further reduce the noise created when the bullet is fired from the firearm. The sound absorbing materials 105 may be hollow cylinders wherein the outer tube 15 has a diameter sufficient to accommodate the sound absorbing materials 105 and the inner tube 20 (as shown in FIG. 9). The sound absorbing materials 105 may be hollow cylinders with a diameter sufficient to accommodate the inner tube 20 (as shown in FIG. 9).

According to some embodiments presently disclosed, the absorbing materials 105 comprises a round cross section as shown in FIG. 10a-b. According to some embodiments presently disclosed, the sound absorbing materials 105 comprises a star shaped cross section as shown in FIG. 11a-b. According to some embodiments presently disclosed, the sound absorbing materials 105 is a flat, rectangular piece of material that can be rolled into a cylinder. According to some embodiments presently disclosed, the sound absorbing materials 105 is a flat, rectangular piece of material that can be rolled around the inner tube 20.

According to some embodiments presently disclosed, the sound absorbing materials 105 comprises muffler packing material, oil filter packing material, fiberglass material, steel mesh material, steel wool material, foam material, and/or any other type of sound reducing materials.

Referring to FIGS. 12a-b, a tool 115 may be used to couple the rear cap 30 with the outer tube 15 and/or to couple the expansion chamber assembly 10 with the barrel 70. Referring to FIGS. 13a-b, the tool 115 comprises two or more protrusions 116 positioned and shaped to mate with two or more through apertures 36. The rear cap 30 may be coupled with the outer tube 15 by inserting the two or more protrusions 116 into the apertures 36 and rotating the rear cap 30 about the outer tube 15 so as to engage the inner screw threads 50 with the outer thread 32 of the rear cap 30. The rear cap 30 may be coupled with the barrel 70 by inserting the two or more protrusions 116 into the apertures 36 and rotating the rear cap 30 about the barrel 70 so as to engage the inner screw threads 34 of the rear cap 30 with the barrel 70's outer thread 71. According to some embodiments, the tool 115 comprises a substantially semi-circular portion 117 to accommodate the barrel 70. According to some embodiments, the tool 115 comprises a handle 118 to allow a user to operate the tool 115.

Referring to FIGS. 12a-b, a tool 120 may be used to couple the front cap 25 with the outer tube 15. Referring to FIGS. 14a-b, the tool 120 comprises two or more protrusions 122 positioned and shaped to mate with two or more apertures 125 (shown in FIGS. 4b-c) in the front cap 25. The front cap 25 may be coupled with the outer tube 15 by inserting the two or more protrusions 122 into the apertures 125 and rotating the front cap 25 about the outer tube 15 so

6

as to engage the inner screw threads 45 with the outer thread 28 of the front cap 25. According to some embodiments, the tool 120 comprises a handle 123 to allow a user to operate the tool 120.

According to some embodiments, the threads described above are continuous. According to some embodiments, the one or more threads described above are V-Thread, Square Thread, Buttress Thread, Reverse Buttress Thread or a combination of two or more of these threads.

While several illustrative embodiments of the invention have been shown and described, numerous variations and alternative embodiments will occur to those skilled in the art. Such variations and alternative embodiments are contemplated, and can be made without departing from the scope of the invention as defined in the appended claims.

As used in this specification and the appended claims, the singular forms "a," "an," and "the" include plural referents unless the content clearly dictates otherwise. The term "plurality" includes two or more referents unless the content clearly dictates otherwise. Unless defined otherwise, all technical and scientific terms used herein have the same meaning as commonly understood by one of ordinary skill in the art to which the disclosure pertains.

What is claimed is:

1. A expansion chamber assembly for a firearm, the expansion chamber assembly comprising:
 - an outer tube comprising a front end and a rear end;
 - a front cap coupled with the outer tube at the front end;
 - a rear cap coupled with the outer tube at the rear end, wherein the rear cap comprises an inner thread configured to engage at least a portion of an outer thread on an exit end of a barrel; and
 - an inner tube removably retained within the outer tube by the front cap and the rear cap, wherein the inner tube comprises one or more through apertures to allow a portion of expanding gasses to move from the inner tube into the outer tube;
 wherein the portion of expanding gases move from the inner tube into the outer tube through one or more through apertures;
 - wherein the portion of expanding gasses move from the outer tube to outside the expansion chamber assembly directly through one or more exit apertures located in the rear cap.
2. The expansion chamber assembly of claim 1 further comprising a sound absorbing materials positioned between the inner tube and the outer tube.
3. The expansion chamber assembly of claim 1, wherein the one or more through apertures allow expanding gasses to move from the inner tube directly into the outer tube.
4. A expansion chamber assembly for a firearm, the expansion chamber assembly comprising:
 - an outer tube comprising a front end and a rear end;
 - a front cap coupled with the outer tube at the front end;
 - a rear cap coupled with the outer tube at the rear end; and
 - an inner tube removably retained within the outer tube by the front cap and the rear cap, wherein the inner tube is positioned between the front cap and the rear cap;
 wherein the rear cap comprises a first through aperture to allow expanding gasses to move from a barrel into the inner tube;
 - wherein the inner tube comprises one or more through apertures to allow a portion of the expanding gasses to move from the inner tube into the outer tube; and
 - wherein the rear cap comprises one or more exit apertures to allow the portion of the expanding gases to exit the expansion chamber assembly.

5. The expansion chamber assembly of claim 4, wherein expanding gasses moving from the barrel into the inner tube travel in a direction that is opposite to the portion of the expanding gases that exit the expansion chamber assembly through the one or more exit apertures.

6. The expansion chamber assembly of claim 4, wherein the portion of the expanding gases exit the expansion chamber assembly adjacent to where the expanding gasses move from the barrel into the inner tube.

7. The expansion chamber assembly of claim 1, wherein the rear cap comprises an outer thread for removably coupling with an inner thread of the outer tube.

8. The expansion chamber assembly of claim 4, wherein the rear cap comprises an outer thread for removably coupling with an inner thread of the outer tube.

9. The expansion chamber assembly of claim 1, wherein the front cap comprises an outer thread for removably coupling with an inner thread of the outer tube.

10. The expansion chamber assembly of claim 4, wherein the front cap comprises an outer thread for removably coupling with an inner thread of the outer tube.

* * * * *