

IN THE UNITED STATES PATENT AND TRADEMARK OFFICE

BEFORE THE PATENT TRIAL AND APPEAL BOARD

SAMSUNG ELECTRONICS CO., LTD.,
SAMSUNG ELECTRONICS AMERICA, INC.

Petitioners,

v.

MASSIVELY BROADBAND LLC.

Patent Owner.

Case No. IPR2025-01595

U.S. Patent No. 8,923,754

**PETITION FOR *INTER PARTES* REVIEW
OF U.S. PATENT NO. 8,923,754**

TABLE OF CONTENTS

	<u>Page</u>
I. INTRODUCTION	1
II. MANDATORY NOTICES.....	1
A. Real Party-in-Interest (37 C.F.R. § 42.8(b)(1))	1
B. Related Matters (37 C.F.R. § 42.8(b)(2)).....	1
1. Related Patent Office Proceedings.....	1
2. Related Litigation.....	1
C. Lead and Backup Counsel and Service Information (37 C.F.R. §§ 42.8(b)(3)-(4)).....	2
D. Payment of Fees (37 C.F.R. § 42.15(a))	3
E. Requirements For <i>Inter Partes</i> Review (37 C.F.R. §§ 42.101(A)-(C), 42.104(A), and 42.018).....	3
III. STATEMENT OF RELIEF REQUESTED AND IDENTIFICATION OF CHALLENGE (37 C.F.R. § 42.104(B)).....	4
IV. BACKGROUND	4
A. '754 Patent	4
1. Earliest Priority Date.....	4
2. Specification	4
3. Prosecution History.....	7
B. Asserted Prior Art	9
1. Ganz (EX1005).....	9
2. Larrick (EX1007).....	10
3. Engels (EX1008).....	12
4. Perlman (EX1011)	13
V. PERSON OF ORDINARY SKILL.....	13
VI. CLAIM CONSTRUCTION.....	13
VII. GROUND 1: GANZ IN COMBINATION WITH LARRICK RENDERS CLAIMS 1-6, 8-13, 15, AND 20-26 OBVIOUS	14
A. Overview and Motivation to Combine	14
B. Limitation-By-Limitation Analysis	20
1. Claim 1	20

2.	Claim 2: The broadband wireless repeater or relay of claim 1 wherein said controller performs a).....	34
3.	Claim 3: The broadband wireless repeater or relay of claim 1 wherein said at least one receiver or transceiver for receiving signals or data and said at least one transmitter or transceiver for transmitting signals or data operate in half duplex.....	34
4.	Claim 4: The broadband wireless repeater or relay of claim 1 wherein said at least one receiver or transceiver for receiving signals or data and said at least one transmitter or transceiver for transmitting signals or data operate in full duplex.....	35
5.	Claim 5: The broadband wireless repeater or relay of claim 1 wherein said at least one receiver or transceiver for receiving signals or data and said at least one transmitter or transceiver for transmitting signals or data operate in simplex.....	36
6.	Claim 6: The broadband wireless repeater or relay of claim 1 wherein said repeater or relay is configured such that when in a network which includes one or more devices which can transmit or receive at an instantaneous or overall occupied bandwidth of 100 MHz or more or have a data transmission rate of 100 Megabits per second or more at least one of said one or more devices has a higher data rate than if said repeater or relay was not present in said network.....	36
7.	Claim 8: The broadband wireless repeater or relay of claim 1 wherein said repeater or relay is configured such that when in a network which includes one or more devices which can transmit or receive at an instantaneous or overall occupied bandwidth of 100 MHz or more or have a data transmission rate of 100 Megabits per second or more at least one of said one or more devices have higher quality of transmission or reception than if said repeater or relay was not present in said network.....	37
8.	Claim 9: The broadband wireless repeater or relay of claim 1 wherein said repeater or relay is configured such that when in a network which includes one or more devices which can transmit or receive at an instantaneous or overall occupied bandwidth of 100 MHz or more or have a data transmission rate of 100 Megabits per second or more at least one of said one or more devices has less interference than if said repeater or relay was not present in said network.....	38
9.	Claim 10: The broadband wireless repeater or relay of claim 1 wherein said repeater or relay is configured such that when in one or more wireless networks which includes one or more devices which can transmit at an instantaneous or overall occupied bandwidth of 100 MHz or more or have a data transmission rate of	

100 Megabits per second or more at least one of said one or more wireless networks has an improved ability to control its capacity than if said repeater or relay was not present in said one or more wireless networks.....39

10. Claim 11: The broadband wireless repeater or relay of claim 1 wherein said signals or data received by said receiver or transceiver for receiving signals or data, or signals or data transmitted by said transmitter or transceiver for transmitting signals or data, or signals or data controlled by said controller include modified, stored, or delayed signals or data.....40

11. Claim 12: The broadband wireless repeater or relay of claim 1 wherein said controller is configured to cause said at least one transmitter or transceiver for transmitting signals or data to transmit modified received data or transmissions to one or more devices at an instantaneous or overall occupied bandwidth of 100 MHz or more or have a data transmission rate of 100 Megabits per second or more.....42

12. Claim 13: The broadband wireless repeater or relay of claim 1 wherein said controller is configured to identify one or more devices in said one or more wireless networks.....42

13. Claim 15: The broadband wireless repeater or relay of claim 1 wherein said controller is self-configurable.....43

14. Claim 20: The broadband wireless repeater or relay of claim 1 wherein said controller performs b).....43

15. Claim 21: The broadband wireless repeater or relay of claim 1 wherein said repeater or relay is configured to be integrated with or in communication with a device selected from the group consisting of a television, a telephone, a cellphone, a computer, a camera, a video system, a monitor, a power plug, a wall outlet, a watch, a cable modem, a vehicle or other moving platform, a game console, and an ultrawideband transceiver or device.....43

16. Claim 22: The broadband wireless repeater or relay of claim 1 wherein one or more of said receiver or transceiver for signal or data reception, said transmitter or transceiver for signal or data transmission, and said controller is embedded in one or more integrated circuit chips.....45

17. Claim 23: The broadband wireless repeater or relay of claim 1 wherein said controller performs c).....46

18. Claim 24: The broadband wireless repeater or relay of claim 1 wherein in c) includes one or more of: i) bandwidth or delay provisioning of repeated or relayed transmissions, ii) application prioritization, iii) prioritizing, delaying or altering of data

	transmissions, traffic, or bandwidth, and iv) monitoring or measuring traffic from one or more devices, users or networks.....	47
19.	Claim 25: The broadband wireless repeater or relay of claim 1 wherein said broadband wireless repeater or relay is configured or configurable for monitoring or measuring traffic passed through, received by or transmitted by said broadband wireless repeater or relay.....	48
20.	Claim 26: The broadband wireless repeater or relay of claim 1 wherein said broadband wireless repeater or relay is configured or configurable to modify at least some received signals or data from one or more devices, users or networks and transmit modified or delayed signals or data to at least one device, network or user via wireless communication.....	49
VIII.	GROUND 2: GANZ AND LARRICK IN COMBINATION WITH ENGELS RENDERS CLAIMS 14 AND 19 OBVIOUS.....	50
A.	Overview and Motivation to Combine	50
B.	Limitation-By-Limitation Analysis	52
1.	Claim 14: The broadband wireless repeater or relay of claim 1 wherein said repeater or relay employs MIMO or adaptive antenna technology.....	52
2.	Claim 19: The broadband wireless repeater or relay of claim 1 wherein at least one of said receiver or transceiver for signal or data reception, at least one of said transmitter or transceiver for signal or data transmission, or said controller is configured for operation in at least one of said one or more wireless networks selected from the group consisting of: a cellular network, an enterprise network, a wireless local area network, or a wireless personal area network.	52
IX.	GROUND 3: GANZ AND LARRICK IN COMBINATION WITH PERLMAN RENDERS CLAIMS 7 AND 15-18 OBVIOUS	53
A.	Overview and Motivation to Combine	53
B.	Limitation-By-Limitation Analysis	54
1.	Claim 7: The broadband wireless repeater or relay of claim 1 wherein said repeater or relay is configured such that when in a network which includes one or more devices which can transmit or receive at an instantaneous or overall occupied bandwidth of 10 MHz or more or have a data transmission rate of 100 Megabits per second or more at least one of said one or more devices has a greater coverage distance than if said repeater or relay was not present in said network.	54

2.	Claim 15: The broadband wireless repeater or relay of claim 1 wherein said controller is self-configurable.....	55
3.	Claim 16: The broadband wireless repeater or relay of claim 1 wherein at least one of said receiver or transceiver for signal or data reception, at least one of said transmitter or transceiver for signal or data transmission, or said controller is configured for operation in at least one of said one or more wireless networks in a moving platform environment.	57
4.	Claim 17: The broadband wireless repeater or relay of claim 1 wherein at least one of said receiver or transceiver for signal or data reception, at least one of said transmitter or transceiver for signal or data transmission, or said controller is configured for operation in at least one of said one or more wireless networks in an indoor environment.	58
5.	Claim 18: The broadband wireless repeater or relay of claim 1 wherein at least one of said receiver or transceiver for signal or data reception, at least one of said transmitter or transceiver for signal or data transmission, or said controller is configured for operation in at least one of said one or more wireless networks in an outdoor environment.	59
X.	CONCLUSION.....	60

EXHIBIT LIST

Exhibit	Description
EX1001	U.S. Patent 8,923,754 (“’754 Patent”)
EX1002	Declaration of Mark Mahon, Ph.D.
EX1003	Intentionally Omitted
EX1004	File History of U.S. Patent 8,923,754
EX1005	U.S. Patent 6,584,080 (“Ganz”)
EX1006	Intentionally Omitted
EX1007	U.S. Patent 7,209,523 (“Larrick”)
EX1008	Patent Cooperation Treaty Patent Application WO 03/058850 (“Engels”)
EX1009	Intentionally Omitted
EX1010	Intentionally Omitted
EX1011	U.S. Patent Application Pub. No. 2004/0160928 (“Perlman”)
EX1012	Intentionally Omitted
EX1013	Curriculum Vitae of Mark Mahon Ph.D.

LIST OF CHALLENGED CLAIMS

Claim	
1[pre]	A broadband wireless repeater or relay, comprising:
1[a]	at least one receiver or transceiver for signal or data reception from one or more devices;
1[b]	at least one transmitter or transceiver for signal or data transmission to one or more devices,
1[c]	wherein the transceiver for signal or data reception and the transceiver for signal or data transmission may be the same or different; and
1[d]	a controller that is configured or configurable for operation in one or more wireless networks, said controller communicating with said at least one receiver or transceiver for signal or data reception and said at least one transmitter or transceiver for signal or data transmission,
1[e]	wherein at least one of said receiver or transceiver for signal or data reception and said transmitter or transceiver for signal or data transmission either or both transmit and receive at an instantaneous or overall occupied bandwidth of 100 MHz or more or have a data transmission rate of 100 Megabits per second or more,
1[f]	wherein said controller is configured or configurable to perform or for performing a plurality of: a) ignore or filter out at least some signal or data transmissions from one or more undesired transmitters, users, networks, data sources, or noise sources; b) instruct one or more devices or networks to ignore or disregard at least some signal or data transmissions of one or more undesired transmitters, undesired users, undesired networks, or noise sources; and c) network provisioning or monitoring.
2	The broadband wireless repeater or relay of claim 1 wherein said controller performs a).
3	The broadband wireless repeater or relay of claim 1 wherein said at least one receiver or transceiver for receiving signals or data and said at least one transmitter or transceiver for transmitting signals or data operate in half duplex.
4	The broadband wireless repeater or relay of claim 1 wherein said at least one receiver or transceiver for receiving signals or data and said at least one transmitter or transceiver for transmitting signals or data operate in full duplex.
5	The broadband wireless repeater or relay of claim 1 wherein said at least one receiver or transceiver for receiving signals or data and said at least one transmitter or transceiver for transmitting signals or data operate in simplex.
6	The broadband wireless repeater or relay of claim 1 wherein said repeater or relay is configured such that when in a network which includes one or more devices which can transmit or receive at an instantaneous or overall occupied bandwidth of 100 MHz or more or have a data transmission rate of 100 Megabits per second or more at least one of said one or more devices has a higher data rate than if said repeater or relay was not present in said network.
7	The broadband wireless repeater or relay of claim 1 wherein said repeater or relay is configured such that when in a network which includes one or more devices

Claim	
	which can transmit or receive at an instantaneous or overall occupied bandwidth of 100 MHz or more or have a data transmission rate of 100 Megabits per second or more at least one of said one or more devices has a greater coverage distance than if said repeater or relay was not present in said network.
8	The broadband wireless repeater or relay of claim 1 wherein said repeater or relay is configured such that when in a network which includes one or more devices which can transmit or receive at an instantaneous or overall occupied bandwidth of 100 MHz or more or have a data transmission rate of 100 Megabits per second or more at least one of said one or more devices have higher quality of transmission or reception than if said repeater or relay was not present in said network.
9	The broadband wireless repeater or relay of claim 1 wherein said repeater or relay is configured such that when in a network which includes one or more devices which can transmit or receive at an instantaneous or overall occupied bandwidth of 100 MHz or more or have a data transmission rate of 100 Megabits per second or more at least one of said one or more devices has less interference than if said repeater or relay was not present in said network.
10	The broadband wireless repeater or relay of claim 1 wherein said repeater or relay is configured such that when in one or more wireless networks which includes one or more devices which can transmit at an instantaneous or overall occupied bandwidth of 100 MHz or more or have a data transmission rate of 100 Megabits per second or more at least one of said one or more wireless networks has an improved ability to control its capacity than if said repeater or relay was not present in said one or more wireless networks.
11	The broadband wireless repeater or relay of claim 1 wherein said signals or data received by said receiver or transceiver for receiving signals or data, or signals or data transmitted by said transmitter or transceiver for transmitting signals or data, or signals or data controlled by said controller include modified, stored, or delayed signals or data.
12	The broadband wireless repeater or relay of claim 1 wherein said controller is configured to cause said at least one transmitter or transceiver for transmitting signals or data to transmit modified received data or transmissions to one or more devices at an instantaneous or overall occupied bandwidth of 100 MHz or more or have a data transmission rate of 100 Megabits per second or more.
13	The broadband wireless repeater or relay of claim 1 wherein said controller is configured to identify one or more devices in said one or more wireless networks.
14	The broadband wireless repeater or relay of claim 1 wherein said repeater or relay employs MIMO or adaptive antenna technology.
15	The broadband wireless repeater or relay of claim 1 wherein said controller is self-configurable.
16	The broadband wireless repeater or relay of claim 1 wherein at least one of said receiver or transceiver for signal or data reception, at least one of said transmitter or transceiver for signal or data transmission, or said controller is configured for operation in at least one of said one or more wireless networks in a moving platform environment.

Claim	
17	The broadband wireless repeater or relay of claim 1 wherein at least one of said receiver or transceiver for signal or data reception, at least one of said transmitter or transceiver for signal or data transmission, or said controller is configured for operation in at least one of said one or more wireless networks in an indoor environment.
18	The broadband wireless repeater or relay of claim 1 wherein at least one of said receiver or transceiver for signal or data reception, at least one of said transmitter or transceiver for signal or data transmission, or said controller is configured for operation in at least one of said one or more wireless networks in an outdoor environment.
19	The broadband wireless repeater or relay of claim 1 wherein at least one of said receiver or transceiver for signal or data reception, at least one of said transmitter or transceiver for signal or data transmission, or said controller is configured for operation in at least one of said one or more wireless networks selected from the group consisting of: a cellular network, an enterprise network, a wireless local area network, or a wireless personal area network.
20	The broadband wireless repeater or relay of claim 1 wherein said controller performs b).
21	The broadband wireless repeater or relay of claim 1 wherein said repeater or relay is configured to be integrated with or in communication with a device selected from the group consisting of a television, a telephone, a cellphone, a computer, a camera, a video system, a monitor, a power plug, a wall outlet, a watch, a cable modem, a vehicle or other moving platform, a game console, and an ultrawideband transceiver or device.
22	The broadband wireless repeater or relay of claim 1 wherein one or more of said receiver or transceiver for signal or data reception, said transmitter or transceiver for signal or data transmission, and said controller is embedded in one or more integrated circuit chips.
23	The broadband wireless repeater or relay of claim 1 wherein said controller performs c).
24	The broadband wireless repeater or relay of claim 1 wherein in c) includes one or more of: i) bandwidth or delay provisioning of repeated or relayed transmissions, ii) application prioritization, iii) prioritizing, delaying or altering of data transmissions, traffic, or bandwidth, and iv) monitoring or measuring traffic from one or more devices, users or networks.
25	The broadband wireless repeater or relay of claim 1 wherein said broadband wireless repeater or relay is configured or configurable for monitoring or measuring traffic passed through, received by or transmitted by said broadband wireless repeater or relay.
26	The broadband wireless repeater or relay of claim 1 wherein said broadband wireless repeater or relay is configured or configurable to modify at least some received signals or data from one or more devices, users or networks and transmit modified or delayed signals or data to at least one device, network or user via wireless communication.

I. INTRODUCTION

Petitioners Samsung Electronics Co., Ltd. and Samsung Electronics America, LLC (“Petitioner”) request *Inter Partes* Review of claims 1-26 of U.S. Patent No. 8,923,754 (“’754 patent”) assigned to Massively Broadband LLC. (“Patent Owner”.) The ’754 patent is directed to “[a]n ultrawideband radio transceiver/repeater [that] provides a low cost infrastructure solution that merges wireless and wired network devices.” (EX1001, Abstract.) As demonstrated below, transceiver/repeater devices using wide frequency bandwidths was ubiquitous in the prior art, and the ’754 patent claims no non-obvious features or implementation.

II. MANDATORY NOTICES

A. Real Party-in-Interest (37 C.F.R. § 42.8(b)(1))

The real parties-in-interest for Petitioner are Samsung Electronics Co., Ltd. and Samsung Electronics America, Inc.

B. Related Matters (37 C.F.R. § 42.8(b)(2))

1. Related Patent Office Proceedings

The ’754 patent is in the same family as U.S. Patent Nos. 7,676,194, 9,667,337, 10,797,783, and 10,224,999. Petitioner has filed IPR petitions against the ’999 patent (IPR2025-01594).

2. Related Litigation

Patent Owner is currently asserting the ’754 patent against Petitioner in

Massively Broadband LLC. v Samsung Electronics Co., Ltd. and Samsung Electronics America, Inc., Case No. 2:25-cv-00608-JRG (E.D. Tex.)

C. Lead and Backup Counsel and Service Information (37 C.F.R. §§ 42.8(b)(3)-(4))

Electronic service may be made on the email addresses identified below and in the accompanying Power of Attorney. Petitioner consents to electronic service at the email addresses listed in the table below and at:

qe-samsung-mbl-ipr@quinnemanuel.com

LEAD COUNSEL	BACK-UP COUNSEL
<p>James M. Glass (Reg. No. 46,729) jimglass@quinnemanuel.com QUINN EMANUEL URQUHART & SULLIVAN, LLP 295 5th Avenue, 9th Floor New York, NY 10010 Tel: (212) 849-7000</p>	<p>John McKee (Reg. No. 65,926) johnmckee@quinnemanuel.com Matthew Robson (<i>pro hac vice</i> forthcoming) matthewrobson@quinnemanuel.com Ron Hagiz (<i>pro hac vice</i> forthcoming) ronhagiz@quinnemanuel.com QUINN EMANUEL URQUHART & SULLIVAN, LLP 295 5th Avenue, 9th Floor New York, NY 10016 Tel: (212) 849-7000'</p> <p>Benjamin Kleinman Reg. No. 66,856 benjaminkleinman@quinnemanuel.com QUINN EMANUEL URQUHART & SULLIVAN, LLP 50 California Street, 22nd Floor San Francisco, CA 94111</p>

	<p>Tel: (415) 875-6600 Fax: (415) 875-6700</p> <p>Quincy Lu (Reg. No. 76,954) quincylu@quinnemanuel.com Jared Kneitel (Reg. No. 51,178) jaredkneitel@quinnemanuel.com QUINN EMANUEL URQUHART & SULLIVAN, LLP 1109 First Avenue, Suite 210 Seattle, WA 98101 Tel: (206) 905-7000</p> <p>Sandy Shen (<i>pro hac vice</i> forthcoming) sandyshen@quinnemanuel.com QUINN EMANUEL URQUHART & SULLIVAN, LLP 1300 I Street NW, Suite 900 Washington, D.C. 20005 Tel: (202) 538-8000</p>
--	--

D. Payment of Fees (37 C.F.R. § 42.15(a))

The Office is authorized to charge the fee required for this Petition (and any additional fees) to Deposit Account No. 50-5708.

E. Requirements For *Inter Partes* Review (37 C.F.R. §§ 42.101(A)-(C), 42.104(A), and 42.018)

Petitioner certifies that the '754 patent is available for *inter partes* review, that Petitioner is not barred or estopped from challenging the '754 claims on the grounds

identified herein, and that the prohibitions of 35 U.S.C. §§ 315(a)-(b) are inapplicable.

III. STATEMENT OF RELIEF REQUESTED AND IDENTIFICATION OF CHALLENGE (37 C.F.R. § 42.104(B))

Petitioner respectfully requests that *inter partes* review of claims 1-26 (“Challenged Claims) on the following grounds:

Ground	Basis	References	Claims
1	§103	Ganz in view of Larrick	1-6, 8-13, 15, and 20-26
2	§103	Ganz and Larrick in further view of Engels	14 and 19
3	§103	Ganz and Larrick in further view of Perlman	7 and 15-18

IV. BACKGROUND

A. '754 Patent

1. Earliest Priority Date

The '754 patent is a pre-AIA patent whose earliest priority date is August 22, 2003 via U.S. Provisional Application Nos. 60/498,324 and 60/496,913 (EX1002, ¶40.)

2. Specification

The '754 patent relates to an ultrawideband radio transceiver/repeater that merges wired and wireless network devices while providing connection to the plant,

flexible repeater capabilities, network security, and traffic flow control for wired and wireless connectivity of devices or networks. (EX1001, Abstract; EX1002, ¶41.)

The ultrawideband repeater described in the '754 patent “serves to ‘repeat’ data signals coming from one or many devices so that other devices, located farther away from the ‘source’ will be able to access the internet, Cable TV, Satellite source, phone/DSL line, or other broadband ‘plant’ source via the repeater.” (EX1001, 6:43-48; EX1002, ¶42.)

The patent describes that “[u]ltrawideband technologies are about to become mainstream, and are described in” various patent applications and publications. (EX1001, 2:5-10; EX1002, ¶43.) The patent also describes that “[t]he IEEE 802.15.3 standards bodies have been developing Physical (PHY) and MAC layer standards for dynamic channel selection and repeater service for UWB, which falls under the general IEEE 802.15.3 standards body.” (EX1001, 2:12-16.) The patent contends that “the presently proposed 802.15.3 standard[] is not adequate to provide one or more of sufficient security, proper traffic filtering, bandwidth provisioning, network management features, or flexibility of networks that can be installed or controlled easily by a consumer. That is to say, the current repeater operation contemplated by 802.15.3 and proposed UWB devices is based on the assumption that a single chip can perform necessary repeater functions, but this functionality alone will not be adequate for the rapid emergence of UWB and the onslaught of wireless data that is

certain to occur.” (*Id.*, 2:37-47; EX1002, ¶43.)

In addition, the patent describes that “IEEE 802.15.3a, the Ultrawideband Physical Layer standard committee, is working on creating a standard that may either be Multiband OFDM transmission (MBOA), with 500 MHz channels, or a Direct Sequence Spread Spectrum impulse radio standard that has broader channel bandwidths (UWB Forum).” (*Id.*, 2:47-53.) Moreover, *the patent describes that UWB chips capable of 100 megabits per second were already commercially available* (*id.*, 2:64-3:4) and that mesh networking will provide efficient network paths that allow very high data rates across the internet (*id.*, 3:1-4; EX1002, ¶44.)

Repeaters are “well known in the art, and they have been manufactured for decades in the cellular and PCS industries, and more recently, ... for the IEEE 802.11a/b marketplace [and] for IEEE 802.11g wireless LAN WiFi standard.” (EX1001, 3:20-26; EX1002, ¶45.)

Contrary to the FCC defining ultrawideband as larger than 500 MHz,¹ the patent defines “ultrawideband” as “any type of electromagnetic signals that have an instantaneous or overall occupied bandwidth of 100 MHz or more and that are used to communicate or to position-locate between 2 or more devices. Such wide

¹ FCC, First Report and Order 02-48. February 2002. The FCC published this formal definition in April 2002, prior to the earliest priority date of the patents.

bandwidths ... generally implies a proportionally higher noise floor power level, which requires UWB devices generally to be physically closer in distant to each other in order to obtain a sufficiently strong signal to noise ratio (SNR).... Thus, repeaters will become necessary to connect devices over greater distances than the range of a single UWB device.” (EX1001, 3:61-4:11; EX1002, ¶46.)

In connection with FIG. 2, the ultrawideband repeater is stated to require careful signal processing that is able to null out noise and interference across the very wide bandwidth used by UWB such as noise from an undesired transmitter or attacker. (EX1001, 9:5-9; EX1002, ¶47.)

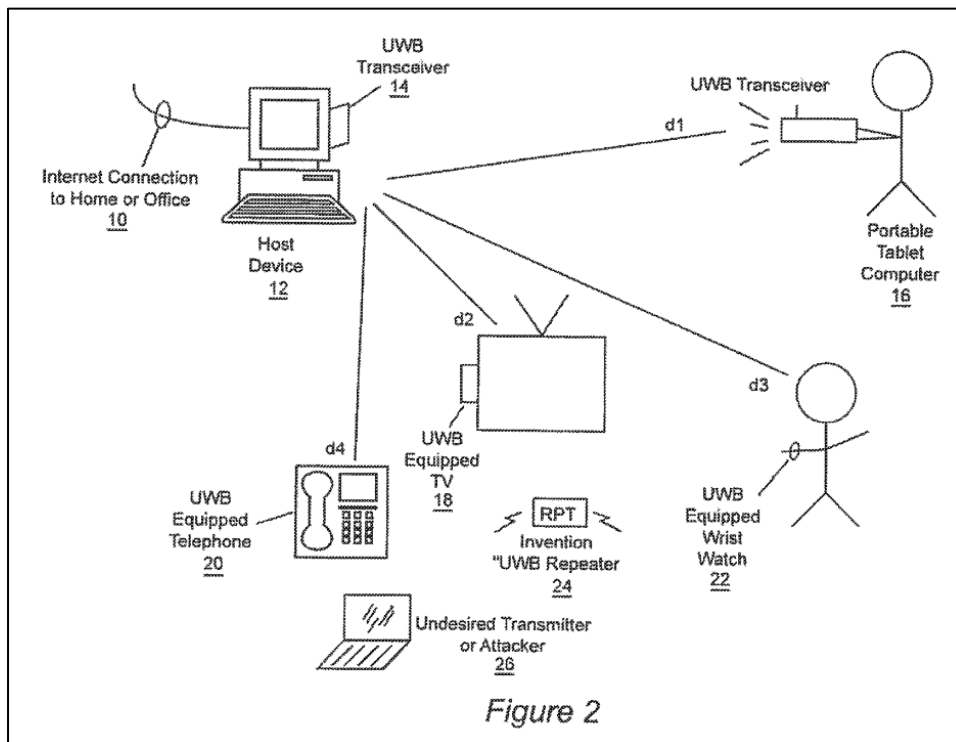

3. Prosecution History

The '754 patent was filed on November 14, 2012 as application 13/088,963,

and claims priority to provisional applications 60/498,324 and 60/496,913. (EX1002, ¶¶48-52.)

On April 9, 2014 an office action issued rejecting pending claims 45, 46, 58, 61, 62, 63, and 65 under 35 U.S.C. 103(a) as being obvious over U.S. Patent Application Publication 2006/0063484 (“Proctor”) in view of U.S. Patent No. 6,952,456 (“Aiello”) and further in view of U.S. Patent No. 5,012,211 (“Young”). (EX1004, April 9, 2014 Office Action.)

Proctor teaches a broadband wireless relay containing a controller configurable for operation in wireless networks and to receive transmissions of one or more UWB devices. (*Id.*) Aiello teaches “wherein said one or more ultrawideband devices either or both transmit and receive electromagnetic signals that have an instantaneous or overall occupied bandwidth of 100 MHz or more or have a data transmission rate of 100 Megabits per second or more.” (*Id.*) Young teaches the use of a low loss bandpass filter to perform filtering and network monitoring. (*Id.*)

On August 7, 2014, the Applicant filed a request for reconsideration, arguing failures of each of the Proctor/Aiello/Young references to disclose the claimed inventions. (EX1004, August 7, 2014 Applicant Remarks.) Applicant argued that Proctor “differs markedly” from the claimed invention, as it “pertains to a repeater having frequency translation.” (*Id.*) According to Applicant, Proctor “filters undesired analog signals in the course of signal processing,” and “does no

controlling.” (*Id.*) Thus, Applicant argued that Proctor “only contemplates frequency translation” and that Proctor “does not perform any function similar to ignoring or filtering out or modifying or delaying signals or data transmissions; instructing at least some networks or devices to ignore or disregard some signals or data; application prioritization; prioritization, delay or altering of data transmissions, traffic, or bandwidth; or monitoring traffic, devices or networks.” (*Id.*) Applicant argued that Aiello and Young also fail to disclose the requisite type of controlling functions, summarizing that “the claimed invention is not a jammer, it is not a mechanical filter, etc. Rather, the claimed invention is specifically designed to repeat or relay. Hence, even if one of ordinary skill in the art were to have full knowledge of Proctor, Aiello, and Young...the combination would not produce or make obvious the claimed invention.” (*Id.*)

The claims were then allowed. (EX1004, August 14, 2014 Notice of Allowance.)

B. Asserted Prior Art

1. Ganz (EX1005)

U.S. 6,584,080 (“Ganz”), “*Wireless Burstable Communications Repeater*,” was filed on January 14, 1999, and was published on June 24, 2003. It is prior art under pre-AIA § 102(a) and § 102(b). (EX1002, ¶¶53-55.)

Ganz discloses “[a] wireless high speed data communication system having a

host radio station connected to a source of data. The host radio station transmits data to a radio repeater that is within a line of sight. The communication system may include numerous repeaters each of which is configured to communicate with each other within a line of sight.” (EX1005, Abstract; emphasis added.)

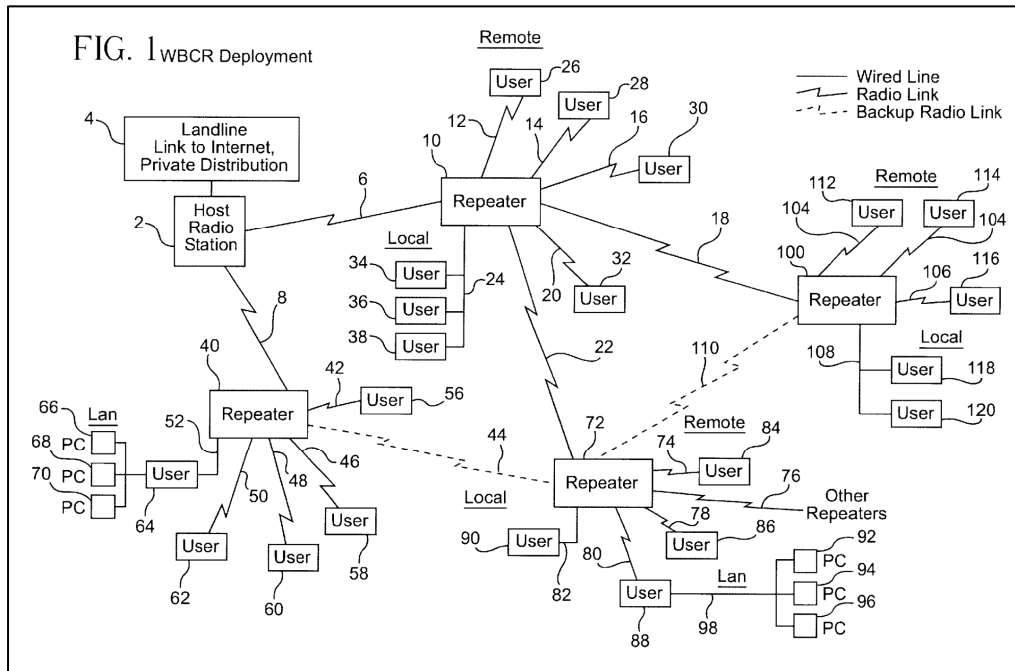

Ganz was not before the examiner during prosecution of the '754 patent.

2. Larrick (EX1007)

U.S. 7,209,523, “*Ultra-wideband Receiver and Transmitter*,” was filed on February 17, 1999, and was published on April 24, 2007. It is prior art under pre-AIA § 102(a). (EX1002, ¶¶56-60.)

Larrick discloses “[a] waveform-adaptive ultra-wideband (UWB) transmitter and noise-tracking UWB receiver for use in communications, object detection and

radar applications.... The UWB transmitter exhibits well defined and controllable spectral characteristics. The UWB transmitter is capable of extremely high pulse repetition frequencies (PRFs) and *data rates in the hundreds of megabits per second* or more, frequency agility on a pulse-to-pulse basis allowing frequency hopping if desired, and extensibility from below HF to millimeter wave frequencies.” (EX1007, Abstract)

In one described embodiment and as shown in FIG. 12B, “[a]n UWB transmitter using a low-level impulse generator and microwave bandpass filter was constructed which generated an L-band UWB signal at a center frequency of 1.5 GHz, *with a 3 dB down bandwidth of 400 MHz.*” (EX1007, 10:61-64.)

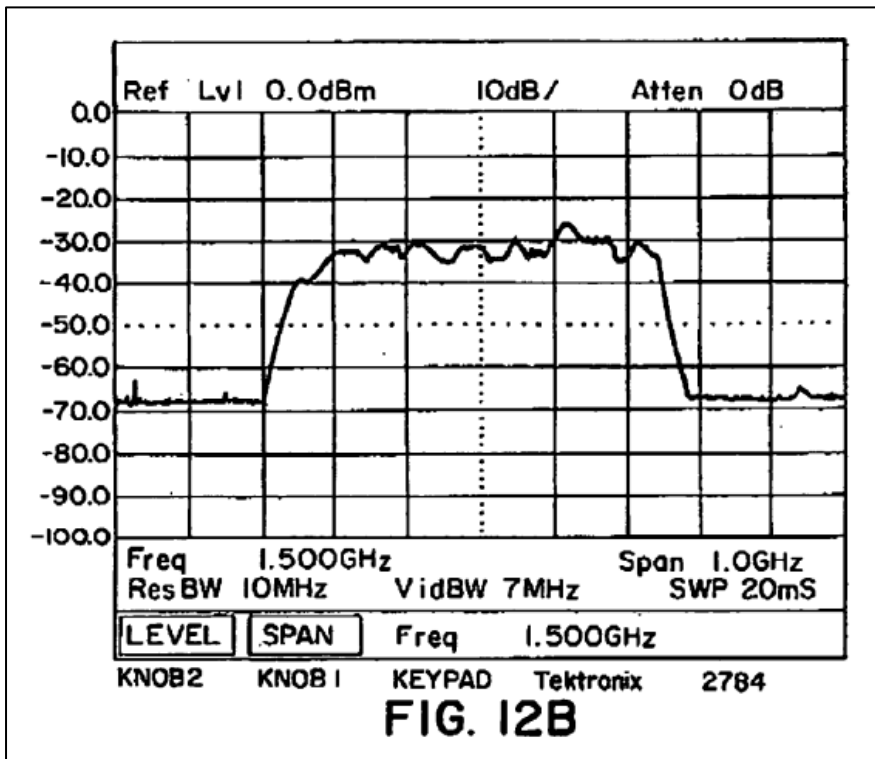
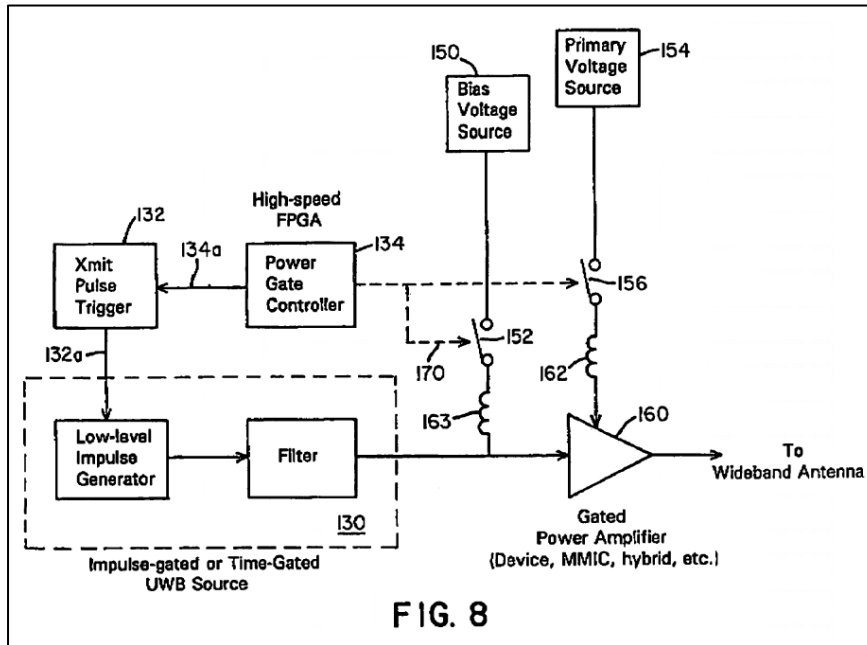

FIG. 8 shows the use of an amplifier 160 that amplifies the output of UWB source 130. (EX1007, 11:36-12:9.)



Larrick was not before the examiner during prosecution of the '754 patent.

3. Engels (EX1008)

Patent Cooperation Treaty Application WO 03/058850 (“Engels”) was filed on January 6, 2003 and published on July 17, 2003. It is prior art under pre-AIA § 102(a). (EX1002, ¶¶61-63.)

Engels discloses “a wireless radio telecommunications system, an indoor-outdoor coupling device for coupling between a telecommunications network, such as a wireless or cable network and an indoor wireless network, especially a LAN, and a method for providing improved communications between the inside and outside of a building.” (EX1008, 1:5-8.)

Engels was not before the examiner during prosecution of the '754 patent.

4. Perlman (EX1011)

U.S. Patent Application Pub. No. 2004/0160928 (“Perlman”) was filed on May 9, 2003. It is prior art under pre-AIA § 102(e). (EX1002, ¶¶64-66.)

Perlman discloses “[a] network for wireless transmission of data” which “includes a source access point, a destination device and a plurality of wireless repeaters that provide a transmission link between the source access point and the destination device. .” (EX1011, Abstract.)

Perlman was not before the examiner during prosecution of the '754 patent.

V. PERSON OF ORDINARY SKILL

A person of ordinary skill in the art as of the asserted priority date (“POSITA”) had at least a Bachelor of Science in electrical engineering or a similar field and at least two years of practical experience in the field of wireless communication applications. More education can supplement for less practical experience, and vice versa. (EX1002, ¶¶67-68.)

Petitioner’s expert, Dr. Mahon, met this level by the priority date. (EX1002, ¶¶67-68.)

VI. CLAIM CONSTRUCTION

No express constructions are required to find the '754 patent claims invalid. As relevant, Petitioner addresses the plain meaning of certain terms in the analysis

for the presented Grounds. (EX1002, ¶¶69-70.) The challenged claims have not been construed in other proceedings.

VII. GROUND 1: Ganz in Combination with Larrick Renders Claims 1-6, 8-13, 15, and 20-26 Obvious²

A. Overview and Motivation to Combine

As discussed in more detail below, Ganz teaches a wireless networking device that receives wireless data, processes that wireless data, and transmits wireless data. Ganz uses a wireless burstable communications repeater. (EX1005, Abstract.) Larrick similarly teaches a wireless networking device that contains an ultra-wideband transmitter and receiver, with data rates of at least 100 megabits per second and bandwidth between 100 and 500 MHz. (EX1002, ¶71.)

A POSITA would have been motivated to incorporate the teachings of Larrick to improve the Ganz system by allowing it to transmit and receive data using wider frequency bands and at higher data speeds. (EX1002, ¶71.) Ganz teaches a wireless repeater system for wirelessly receiving and transmitting data, and Larrick provides additional detail on how to use ultra-wide band frequency bandwidths and data speeds to wirelessly transfer data. (EX1002, ¶71.) The teachings of Ganz are

² Unless noted otherwise, all emphases in quotes and annotations to figures from prior art references are added.

complementary to Larrick, and a POSITA would have recognized that Larrick's teachings could be easily implemented into Ganz without technical challenge and with a reasonable expectation of success. (EX1002, ¶71.)

Ganz addresses wireless burstable communications repeaters for creating network infrastructures while Larrick discloses an ultra-wideband (UWB) transmitter and receiver system with controllable spectral characteristics. Ganz, which discloses efficient spectrum utilization in a shared wireless environment, would benefit from Larrick's waveform-adaptive UWB transmitter which provides "well defined and controllable spectral characteristics." (EX1007, Abstract.) These technologies address different aspects of wireless communication that could naturally work together including Larrick's use of wider frequency bandwidths than those disclosed in Ganz. (EX1002, ¶72.)

The "wireless high speed data communication system" of Ganz (EX1005, Abstract), would benefit from Larrick's UWB technology which enables even faster data speeds such as "extremely high pulse repetition frequencies (PRFs) and data rates in the hundreds of megabits per second" (EX1007, Abstract; EX1002, ¶73.).

Larrick's UWB technology, which offers waveform adaptation that could improve signal propagation in challenging environments, would be beneficial to Ganz which addresses communication problems where "extended coverage areas are desired and line-of-sight conditions do not exist." (EX1005, 1:62-63; EX1002, ¶74.)

Like Ganz, Larrick arises in the field of wireless communication networks and is addressed to increasing transmitting information wirelessly. (EX1007, Abstract; EX1002, ¶74.)

Enhanced Modulation Techniques

The combination would particularly benefit from the complementary modulation approaches described in both patents. Larrick introduces sophisticated UWB signal generation methods that would significantly enhance the Ganz system:

- Larrick’s “waveform-adaptive” approach provides precise control over UWB signal characteristics through an “impulse-gated oscillator” that allows “precise control of radiated frequency” governed by “the choice of oscillator which has a known stable frequency.” (EX1007, 5:62-65.)
- Larrick supports advanced modulation including phase modulation where “oscillator phase may also be controlled to generate an additional phase modulation.” (EX1007, 5:67-6:1.)
- Larrick enables “frequency agility on a pulse-by-pulse basis allowing frequency hopping if desired” (EX1007, Abstract), which would enhance the frequency hopping capabilities already present in Ganz’ system where “three different hopping sequence sets are established with twenty-six (26) hopping sequences per set.” (EX1005, 7:21-23.)
- Larrick describes a “time-gated oscillator” approach using high-speed

switches to create “a sub-nanosecond microwave burst” with controllable bandwidth. (EX1007, 15:1-9.)

These advanced modulation capabilities would pair effectively with Ganz’ network protocols, particularly the “burstable packet multi access/collision avoidance (BPMA/CA) protocol” (EX1005, 5:16-17) that Ganz uses to improve network efficiency. (EX1002, ¶77.)

Multi-User Capability and Spectral Efficiency

Ganz identifies inefficient spectrum utilization in conventional systems due to "polling" which leads to "time slots [going] unused when a polled radio has no data to transfer.” (EX1005, 1:58-60; EX1002, ¶79.) Combining this with Larrick’s ability to control “center frequency and bandwidth” (EX1007, 6:14-15) on a “pulse-by-pulse basis” (EX1007, 5:52) would create an advanced multiple access scheme where:

- Different users could be assigned different UWB center frequencies, enhancing Ganz’ ability to support “multiple segments to be installed in a common geographical area without interfering with each other.” (EX1005, 8:17-18.)
- The network could dynamically allocate bandwidth based on user requirements, improving on Ganz’ goal of providing “high communication speeds” in a “multi-user (access) environment.” (EX1005, 2:41-42.)

- Larrick’s “well defined and controllable spectral characteristics” (EX1007, Abstract) would enhance Ganz’ ability to segment networks where “data bandwidth can be increased beyond 1.5 Mb/s for higher data transfer rate.” (EX1005, 8:39-40; EX1002, ¶79.)

Link Quality Assessment and Power Efficiency

Ganz describes sophisticated link testing where “control packets” with “sequence numbers” allow the system to “know whether packets were lost either on the way to the destination, or on the way back to the source node” (EX1005, 12:28-31). This capability would pair effectively with Larrick’s adaptable UWB parameters to create a system that could dynamically adjust transmission parameters based on link quality. (EX1002, ¶81.)

Additionally, Larrick’s “gated power amplifier” with “the unique feature of high power efficiency as the power amplifier is only turned on for approximately the duration of the UWB pulse” (EX1007, 6:42-45) would be particularly valuable in Ganz’ repeater network, especially for remote installations. (EX1002, ¶82.)

Data Rate Advancement and Industry Trends

At the time of the ‘999 patent, a significant industry trend was toward higher data rates in wireless communication systems. Ganz’ system specifically aims to overcome the “reduction of throughput by a factor of two” that occurs in half-duplex systems (EX1005, 1:19-20) and discusses achieving “information throughput in

each segment is preferably at least 1.5 Mb/s, equal to a full dedicated T-1 line rate.” (EX1005, 8:24-26.) However, Ganz acknowledges bandwidth limitations within specific frequency bands, noting that “with an 11-bit modulation sequence, a transmission is spread over a 20 MHz bandwidth.” (EX1005, 8:26-27; EX1002, ¶84.)

Larrick directly addresses these limitations by providing technology that enables “data rates in the hundreds of megabits per second or more” (EX1007, Abstract) and explicitly states that prior UWB systems had limitations that prevented higher data rates. (*E.g.*, EX1007, 5:41-44.) Larrick’s UWB system operates with bandwidths substantially greater than those mentioned in Ganz, with examples showing bandwidths of “400 MHz” (EX1007, 10:63-64) and “over 2 GHz.” (EX1007, 15:41-42; EX1002, ¶85.)

These significant improvements in data rate capabilities – from Ganz’ 1.5 Mb/s to Larrick’s “hundreds of megabits per second” – represent precisely the kind of technological advancement that would motivate a POSITA to combine these references. The substantially increased bandwidth of Larrick’s UWB system (400 MHz and greater compared to Ganz’ 20 MHz) would directly enable these higher data rates. (EX1002, ¶86.)

The combination of Ganz and Larrick would have a reasonable expectation of success. Larrick provides technical details for its ultra-wideband transmitter and

receivers, explaining how they can operate at higher bandwidths and data rates. It would have been well-within the skill of an ordinary artisan to implement Larrick's teachings into Ganz' repeater systems. (EX1002, ¶87.)

In the analysis below, the combined prior art system will be referred to as Ganz/Larrick.

B. Limitation-By-Limitation Analysis

1. Claim 1

- a) **1[pre] A broadband wireless repeater or relay, comprising:**

To the extent the preamble is limiting, Ganz discloses this limitation. (EX1002, ¶¶89-91.) Ganz's invention "relates generally to a radio communications repeater, and more particularly relates to a radio communications repeater system for high-speed data communication which enables multiple users to access a common geographically distributed radio channel. (EX1005, 1:7-12). Ganz further explains that "[t]he radio/data link element circuits" within its wireless burstable communications repeater (WBCR) "can incorporate an IEEE 802.11 specification, the disclosure of which is incorporated herein by reference, which calls for two different physical layer implementations: frequency hopping spread spectrum (FHSS) and direct sequence spread spectrum (DSSS)." (EX1005, 7:12-16; EX1002, ¶89.)

To the extent PO argues that 1[pre] is not disclosed by Ganz, it is likewise expressly disclosed by Larrick, and a POSITA would have been motivated to modify Ganz's system to include Larrick's teachings for the reasons discussed in Section VII.A. Larrick discloses "[a] waveform-adaptive ultra-wideband (UWB) transmitter and noise-tracking UWB receiver for use in communications, object detection and radar applications." Larrick also claims "[a] communication system utilizing an ultra-wideband (UWB) transmitter" (EX1007, 24:52-53) and "[a] method of communicating data by transmitting and detecting an ultra wideband UWB pulse." (*id.*, 27:17-18). A POSITA would understand that "wideband" is *broadband*. (EX1002, ¶90.)

Thus, as further discussed in the below limitations, Ganz/Larrick discloses a broadband wireless repeater or relay. (EX1002, ¶91.)

b) 1[a] at least one receiver or transceiver for signal or data reception from one or more devices;

Ganz/Larrick discloses this limitation. (EX1002, ¶¶92-96.)

Ganz discloses a wireless burstable communications repeater (WBCR) that includes a first transceiver circuit 132 and a second transceiver circuit 140. (EX1005, 3:64-4:21.) A block diagram of a WBCR functional architecture is illustrated in FIG. 2 including the first and second transceiver circuits. (EX1005, 3:64-4:21; EX1002, ¶93.)

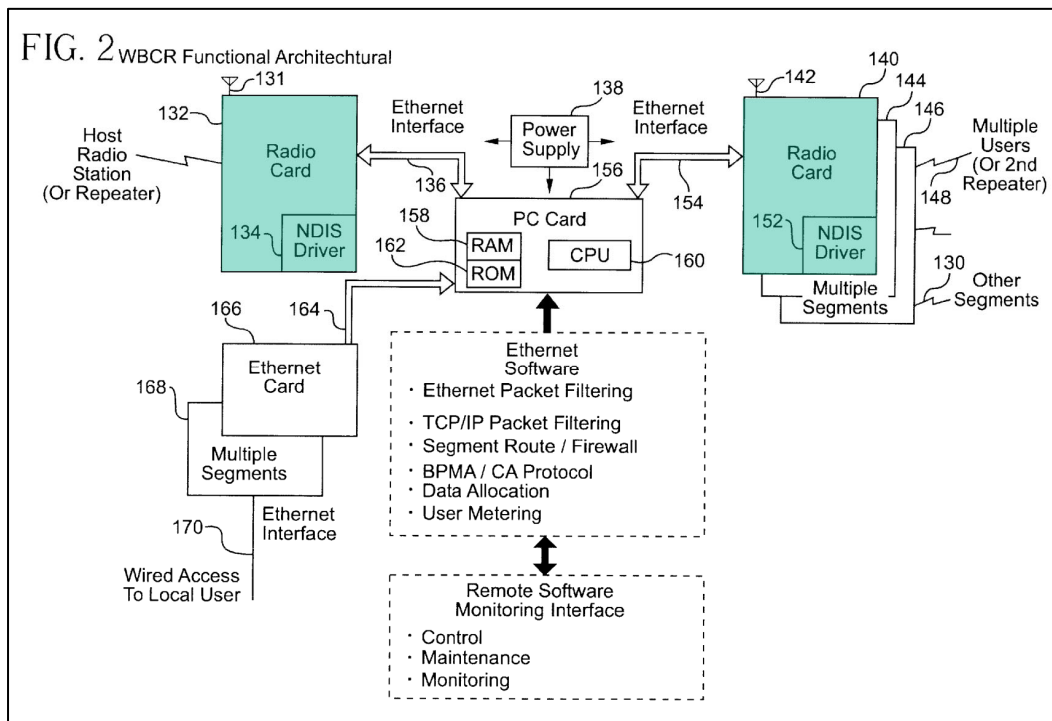

Ganz describes that “[t]he WBCR functions, such that the data packets coming from the user side, are *received* by the second radio transceiver circuit 140.” (EX1005, 4:22-24.) Further, the second radio transceiver circuit 140 “provides multiple radio frequency access to remotely distributed users and/or other WBCRs.” (EX1005, 4:9:12; EX1002, ¶94.)

Additionally, Ganz explains that the first radio transceiver circuit 132 “provides the radio frequency link to a host radio station and, optionally, to one or more repeaters.” (EX1005, 4:8-12.) During a full data stream transfer, data packets can be “*receiv[ed]*...from the host radio station” by the first radio transceiver circuit 132 before being “transmitted to the user” via the second radio transceiver circuit 140. (EX1005, 4:30-35; EX1002, ¶95.)

Thus, Ganz discloses at least one transceiver for signal or data reception from one or more devices. (EX1002, ¶96.)

c) **1[b] at least one transmitter or transceiver for signal or data transmission to one or more devices,**

Ganz/Larrick-discloses this limitation. (EX1002, ¶¶97-101.)

As described above, Ganz discloses a wireless burstable communications repeater (WBCR) containing at least two transceivers shown in FIG. 2. (EX1005, 3:64-4:21; EX1002, ¶98.)

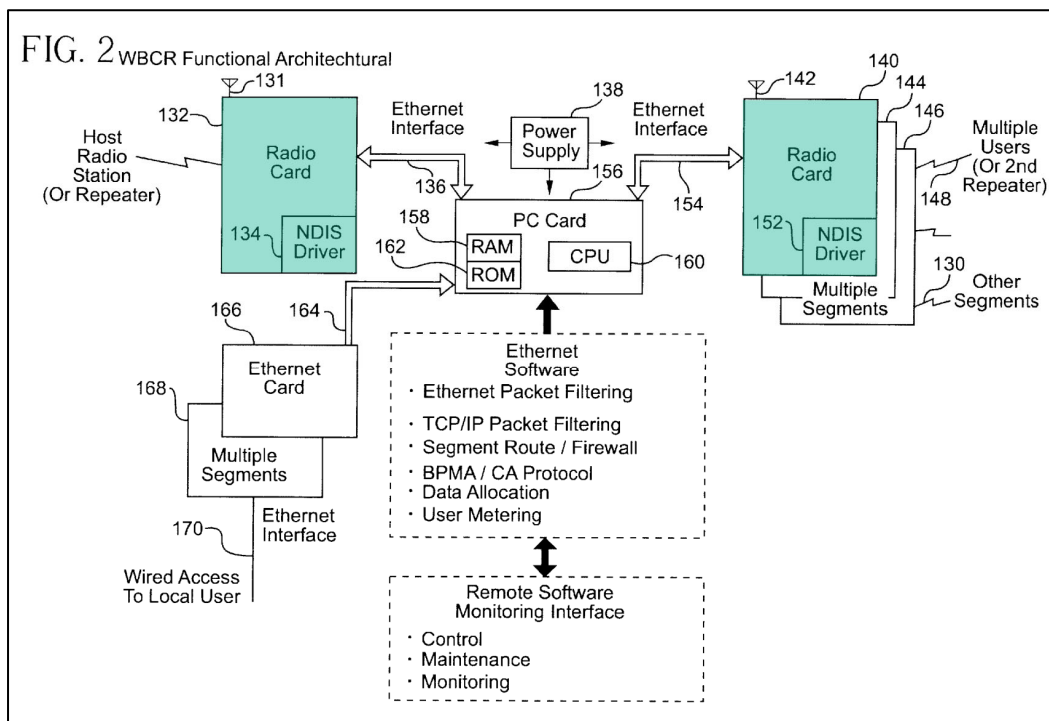

Ganz explains that the first radio transceiver circuit 132 “provides the radio frequency link to a host radio station and, optionally, to one or more repeaters.” (EX1005, 4:8-12; EX1002, ¶99.) During a full data stream transfer, data packets can

be “receiv[ed]...from the host radio station” by the first radio transceiver circuit 132 before being “*transmitted* to the user” via the second radio transceiver circuit 140. (EX1005, 4:30-35; EX1002, ¶99.)

Additionally, Ganz describes that “[t]he WBCR functions, such that the data packets coming from the user side, are received by the second radio transceiver circuit 140... before being *retransmitted* by the radio transceiver circuit” to the host radio station. (EX1005, 4:22-26.) Further, the second radio transceiver circuit 140 “provides multiple radio frequency access to remotely distributed users and/or other WBCRs.” (EX1005, 4:9:12; EX1002, ¶100.)

Thus, Ganz discloses at least one transceiver for signal or data transmission from one or more devices. (EX1002, ¶101.)

d) 1[c] wherein the transceiver for signal or data reception and the transceiver for signal or data transmission may be the same or different; and

Ganz/Larrick discloses this limitation. (EX1002, ¶¶102-103.) According to Ganz, “[t]he radio transceiver circuit 132, provides the radio frequency link to a host radio station and, optionally, to one or more repeaters. The second radio transceiver circuit 140, provides multiple radio frequency access to remotely distributed users and/or other WBCRs.” (EX1005, 4:8-21.) Thus, Ganz discloses multiple transceivers that may perform both signal or data transmission and reception, and thereby discloses wherein the transceiver for signal or data reception and the

transceiver for signal or data transmission may be different or the same. (EX1002, ¶103.)

- e) **1[d] a controller that is configured or configurable for operation in one or more wireless networks, said controller communicating with said at least one receiver or transceiver for signal or data reception and said at least one transmitter or transceiver for signal or data transmission,**

Ganz/Larrick discloses this limitation. (EX1002, ¶¶104-106.)

Ganz discloses a wireless burstable communications repeater (WBCR) containing a “computer circuit 156” that “*performs the controlling functions* within the WBCR and includes the processor **160** (e.g., 486 CPU or equivalent), the RAM circuit **158** and the ROM circuit **162.**” (EX1005, 4:15-21; EX1002, ¶105.)

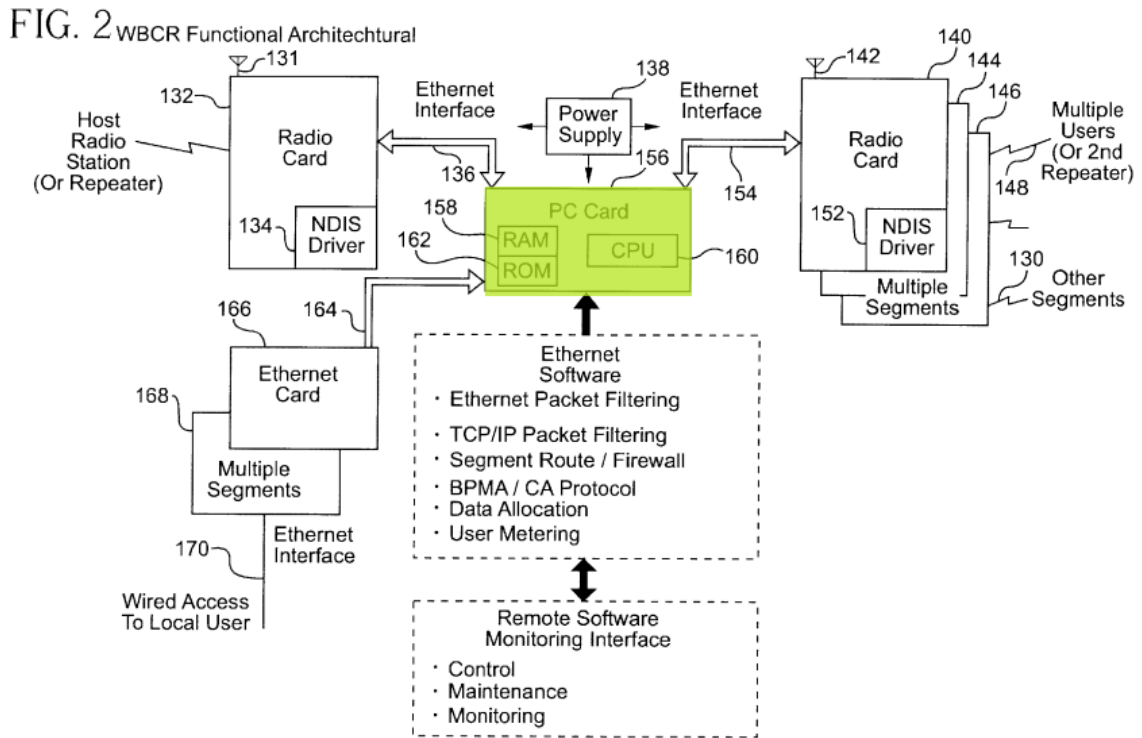

As is evident in FIG. 2 above, the computer circuit communicates with each transceiver circuit 132 and 140. (EX1002, ¶106.) Such communications are performed with an “NDIS [network device interface specification] driver 134, 152, which provides the Ethernet transceiver 136, 154, to the computer circuit 156.” (EX1005, 4:13-15; EX1002, ¶106.)

- f) **1[e] wherein at least one of said receiver or transceiver for signal or data reception and said transmitter or transceiver for signal or data transmission either or both transmit and receive at an instantaneous or overall occupied bandwidth of 100 MHz or more or have a data transmission rate of 100 Megabits per second or more,**

Ganz/Larrick-discloses this limitation. (EX1002, ¶¶107-114.)

Ganz discloses a wireless burstable communications repeater (WBCR). A block diagram of a WBCR functional architecture is illustrated in FIG. 2 including a radio transceiver circuit 132 and a second radio transceiver circuit 140. (EX1005, 3:64-4:21; EX1002, ¶108.)

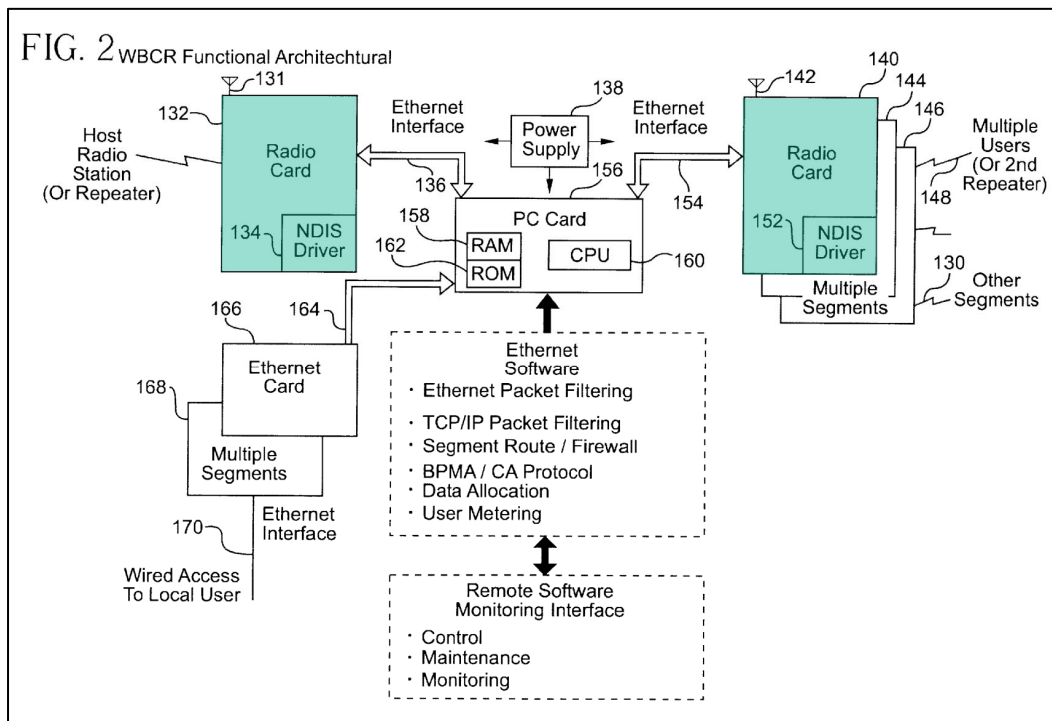

Ganz does not expressly disclose that the transceivers are configured for transmitting and receiving at an instantaneous or overall occupied bandwidth of 100 MHz. However, Larrick discloses a transceiver using the claimed bandwidth and as discussed above, a POSITA would have been motivated to combine Ganz and Larrick. (EX1002, ¶109.)

Larrick “relates to the field of ultra-wideband communication systems. More particularly, [Larrick] relates to the controlled transmission and reception of ultra-wideband electromagnetic pulses.” (EX1007, 1:21-24) Larrick discloses “UWB transmitters which generate UWB signals having controllable spectral characteristics.” (*Id.*, 9:21-23.) “[U]nlike direct high-power impulse excitation of an antenna as in conventional UWB transmitters, low-level impulse excitation

of bandpass filter 102 provides complete control over all aspects of the spectral emissions of the UWB transmitter. This is because the spectral emissions are determined exactly by the characteristics of bandpass filter 102, for instance by the center frequency, bandwidth, out of band rejection and skirt responses.” (*Id.*, 11:26-35; EX1002, ¶110.)

In one described embodiment and as shown in FIG. 12A, “[a]n UWB transmitter using a low-level impulse generator and microwave bandpass filter was constructed which generated an L-band UWB signal at a center frequency of 1.5 GHz, *with a 3 dB bandwidth of 400 MHz.*” (EX1007, 10:61-64; EX1002, ¶111.)

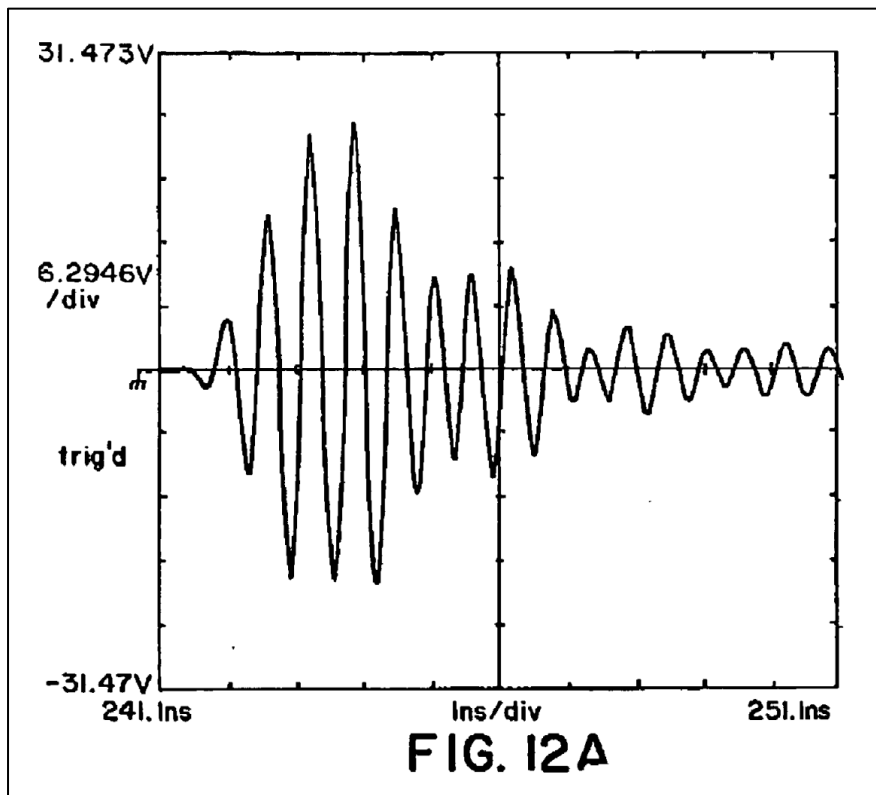

FIG. 12B shows the frequency spectrum of the UWB signal shown in

FIG. 12A. “The particular filters used were L-band bandpass filters, with a center frequency of 1.5 GHz, a 1 dB bandwidth of 400 MHz, a 3 dB bandwidth of 500 MHz, rejection at 1 GHz of greater than 30 dB down.” (EX1007, 10:65-11:4; EX1002, ¶112.)

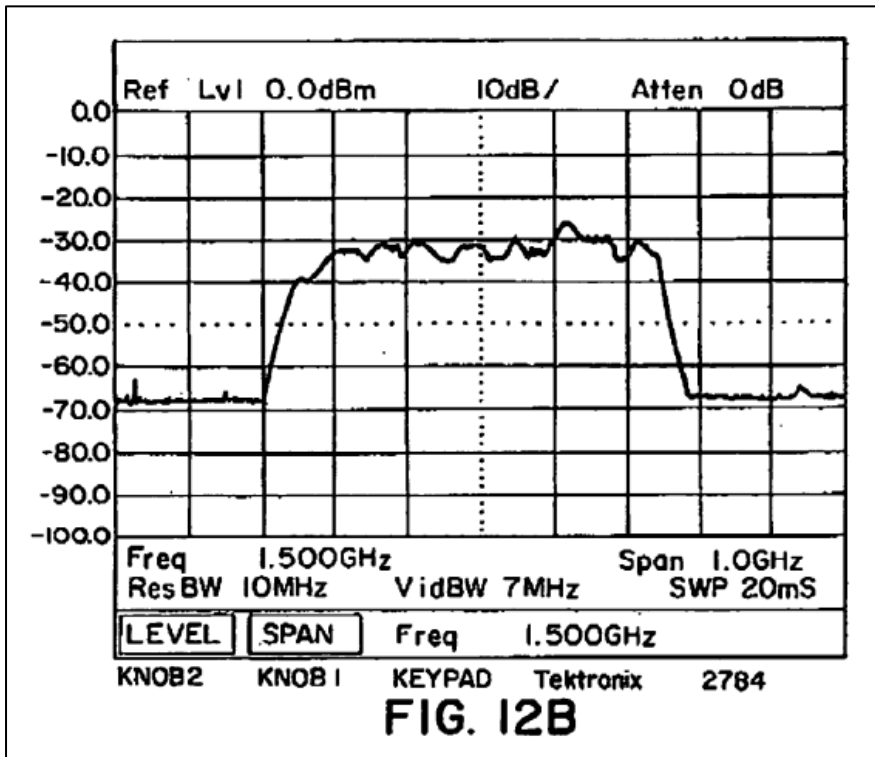
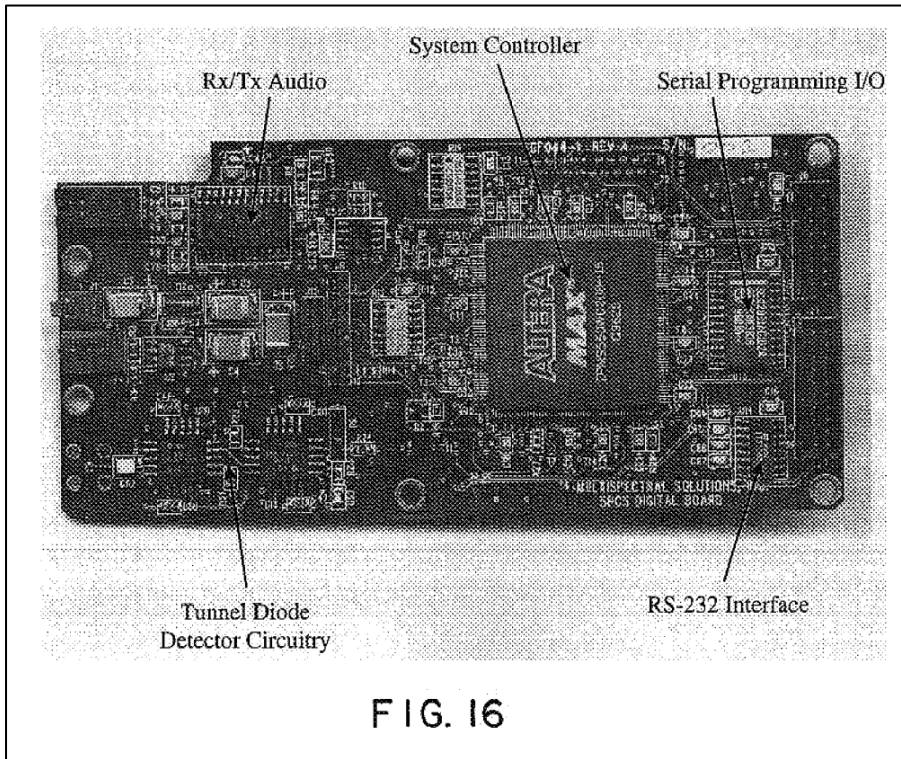

FIG. 16, “a photograph of a circuit board of a transceiver utilizing the present invention” (*id.*; 9:7-8), “shows the UWB receiver imbedded in a full duplex, voice/data ultra wideband transceiver. The RF section of this particular unit (lower left hand side) is wideband from a few MHz to beyond 4 GHz. Tunnel diodes with adequate response characteristics to 26 GHz and beyond are currently available, and thus *the UWB receiver can readily accommodate a wide variety of center*

frequencies between a few MHz upwards toward 26 GHz.” (Id.; 21:54-61)

(EX1002, ¶¶113-114.)



A POSITA would have understood that the ultra-wideband transmitter on the same circuit board as the ultra-wideband receiver would be designed or calibrated to transmit transmissions to the ultra-wideband receiver of the transceiver. Larrick describes and shows the calibration of the receiver. (EX1007, FIG. 15 and 19:35-21:12) In the object detection applications described in Larrick, it would be advantageous if not required that the transmitter have the same frequency bandwidth as the receiver. (EX1002, ¶114.) Larrick discloses a transceiver with the claimed data rates and as discussed above, a POSITA would have been motivated to combine

Ganz and Larrick. In particular, Larrick discloses that its ultra-wideband transceiver is capable of “data rates in the *hundreds of megabits per second* or more, frequency agility on a pulse-to-pulse basis allowing frequency hopping if desired, and extensibility from below HF to millimeter wave frequencies.” (EX1007, Abstract; EX1002, ¶114.)

- g) **1[f] wherein said controller is configured or configurable to perform or for performing a plurality of: a) ignore or filter out at least some signal or data transmissions from one or more undesired transmitters, users, networks, data sources, or noise sources; b) instruct one or more devices or networks to ignore or disregard at least some signal or data transmissions of one or more undesired transmitters, undesired users, undesired networks, or noise sources; and c) network provisioning or monitoring.**

Ganz/Larrick discloses this limitation. (EX1002, ¶¶115-120.)

“a) ignore or filter out at least some signal or data transmissions from one or more undesired transmitters, users, networks, data sources, or noise sources”

Ganz discloses that its WBCR includes a “firewall circuit 222,” which can “read IP addresses and protect the gates and authorize access by users,” and also “be programmed to pass through what ever services are required by the user without interference.” (EX1005, 10:33-42; EX1002, ¶116.) As was known with firewalls, they “can also block traffic from the Internet to the internal network, but permit internal users to communicate with the Internet.” (EX1005, 10:33-42; *see also* 13:2-

4 (“The firewall 268, drops packets that don’t meet its rules for valid traffic.”) A POSITA would have understand that, in other words, a firewall processes received data packets by inspecting their origin (*e.g.* Internet vs. internal) or the targeted service and blocking or allowing the data packet. (EX1002, ¶116.)

Ganz also discloses that the WBCR performs “IP filtering,” which “allows for certain data packets to be blocked, *processed* according to QoS policies and used to assess and sort according to traffic load on each WBCR radio segment.” (EX1005, 11:45-48.) IP filtering also “automatically drops (destroys) incorrectly formed packets or those which the system has been programmed to reject.” (*Id.*, 12:70-13:2; EX1002, ¶117.)

Thus, a POSITA would understand that the controller in Ganz’s WBCR is configurable to “ignore or filter out at least some signal or data transmissions,” from undesired transmitters, users, networks, data sources, or noise sources. (EX1002, ¶¶116-118.)

“b) instruct one or more devices or networks to ignore or disregard at least some signal or data transmissions of one or more undesired transmitters, undesired users, undesired networks, or noise sources”

As discussed above, Ganz discloses ignoring or filtering out at least some signal or data transmissions of undesired transmitters, users, networks, data sources, or noise sources. (EX1002, ¶119.) Given that Ganz explains that its WBCR is configured to “*communicate with at least one end user* by either a direct electrical

connection or a wireless connection” (EX1005, 2:46-50.), it would have been obvious to a POSITA that Ganz’s WBCR could also perform the function of “instruct[ing] one or more devices or networks to ignore or disregard at least some signal or data transmissions.” (EX1002, ¶119.) Ganz already discloses that its WBCR has information on “undesired” signal or data transmissions, as a well as means of communicating that information. Thus, a POSITA would have known that modifying Ganz’s WBCR to communicate information on “undesired” signal or data transmissions, thereby “instructing” end user devices to ignore or disregard those signal or data transmissions, could be done without technical challenge and with a reasonable expectation of success. (EX1002, ¶119.)

“c) network provisioning or monitoring”

Ganz describes software controlled radio/data communications that perform ***“[m]onitoring and control of the WBCR.”*** (EX1005, 5:47-48; EX1002, ¶120.) As such, “[t]hroughput speeds and data packet drop rates can be measured periodically and corrective steps taken to adjust the radio parameters remotely.” (EX1005, 5:51-54.) “The controlling functions implemented as part of the BPMA/CA protocol provide for remote dynamic load balancing among the users, and individually enhancing or reducing the allowable user packet size requests, thereby ensuring efficient network utilization for all users.” (EX1005, 5:54-58.) Additionally, “[b]asic maintenance functions are performed remotely as well, such as adding new users

and user ID's, and updating user priority codes.” (EX1005, 5:58-61). Thus, a POSITA would understand that Ganz discloses that its controller performs network provisioning or monitoring. (EX1002, ¶120.)

2. Claim 2: The broadband wireless repeater or relay of claim 1 wherein said controller performs a).

For the reasons discussed above in limitation 1[f], Ganz/Larrick discloses this limitation. (EX1002, ¶121.)

3. Claim 3: The broadband wireless repeater or relay of claim 1 wherein said at least one receiver or transceiver for receiving signals or data and said at least one transmitter or transceiver for transmitting signals or data operate in half duplex.

Ganz/Larrick discloses this limitation. (EX1002, ¶¶122-123.) Ganz describes that “the present invention [] provide[s] a radio communications repeater which is capable of full data rate transfers in *half-duplex systems*.” (EX1005, 2:17-19.)

To the extent PO argues that claim 3 is not disclosed by Ganz, it is likewise expressly disclosed by Larrick, and a POSITA would have been motivated to modify Ganz’s system to include Larrick’s teachings for the reasons discussed in Section VII.A. (EX1002, ¶123.) Larrick discloses that its UWB transceiver has “high speed operation [that] enables full duplex or two-way transmission and reception of stereo quality voice, video imagery and other data rate critical applications.” (EX1007, 17:2-5.) A POSITA would understand that Larrick is describing that its UWB

transceivers can operate in either full duplex or half-duplex, as “two-way transmission and reception” is contrasted with “full duplex” and therefore indicates the transmission/reception is not performed simultaneously (*i.e.* half-duplex). (EX1002, ¶123.) To the extent PO argues otherwise, a POSITA would have found that in the Ganz/Larrick combination, it would be obvious for receiving and transmitting of signals to operate in half-duplex, as disclosed in Ganz. A POSITA would be motivated to operate in half-duplex as half-duplex requires cheaper and simpler hardware, as it does not require self-interference cancellation. This is a particular concern for full-duplex UWB transceivers where there is a potential for the transmitter to overwhelm the receiver given the large bandwidth. (EX1002, ¶123.)

4. **Claim 4: The broadband wireless repeater or relay of claim 1 wherein said at least one receiver or transceiver for receiving signals or data and said at least one transmitter or transceiver for transmitting signals or data operate in full duplex.**

Ganz/Larrick discloses this limitation. (EX1002, ¶¶124-125.) Ganz describes a communication system comprising “a plurality of wireless communication repeaters wherein *each repeater is adapted for two way wireless full-duplex communication* with at least one of the host radio station and another repeater within a line-of-sight of the repeater to enable communication between the host radio station and repeaters beyond a line-of-sight of the host radio station.” (EX1005,

13:15-20; *see also, id.*, 14:33-38 and 15:41-58.) To the extent PO argues that claim 4 is not disclosed by Ganz, it is likewise expressly disclosed by Larrick, and a POSITA would have been motivated to modify Ganz's system to include Larrick's teachings for the reasons discussed in Section VII.A. (EX1002, ¶125.) Larrick discloses that its UWB transceiver has "high speed operation [that] enables *full duplex or two-way transmission and reception* of stereo quality voice, video imagery and other data rate critical applications." (EX1007, 17:2-5; EX1002, ¶125.)

5. **Claim 5: The broadband wireless repeater or relay of claim 1 wherein said at least one receiver or transceiver for receiving signals or data and said at least one transmitter or transceiver for transmitting signals or data operate in simplex.**

Ganz/Larrick discloses this limitation. (EX1002, ¶¶126-127.) Ganz discloses a transceiver operating in both half-duplex and full-duplex. *See* claims 3, 4 above. A POSITA would understand that a system containing transceivers that operate in half-duplex and full-duplex would be easily modifiable to operate in simplex, as it would require transmission of information in only a single direction rather than in two directions. (EX1002, ¶127.)

6. **Claim 6: The broadband wireless repeater or relay of claim 1 wherein said repeater or relay is configured such that when in a network which includes one or more devices which can transmit or receive at an instantaneous or overall occupied bandwidth of 100 MHz or more or have a data transmission rate of 100 Megabits per second or more at least one of said one or more devices has a higher data rate**

than if said repeater or relay was not present in said network.

Ganz/Larrick discloses this limitation. (EX1002, ¶¶128-130.) Ganz discloses software that performs “monitoring and control” of its WBCR that periodically measures “throughput speeds and data packet drop rates” in the system. (EX1005, 5:47-54.) The software can then perform “controlling functions” that provides for “remote dynamic load balancing among the users, and individually enhancing or reducing the allowable user packet size requests, thereby ensuring efficient network utilization for all users.” (EX1005, 5:55-61.) A POSITA would understand that this “load balancing” and “efficient network utilization” results in higher data rates for one or more devices within the network. (EX1002, ¶129.)

Ganz does not expressly disclose that its transmitter/receiver is configured for receiving wireless data through signals that have an occupied bandwidth of 100MHz or more. However, Larrick discloses a receiver using the claimed bandwidth and as discussed above, a POSITA would have been motivated to combine Ganz and Larrick. *See* claim 1[e] above. (EX1002, ¶130.)

7. **Claim 8: The broadband wireless repeater or relay of claim 1 wherein said repeater or relay is configured such that when in a network which includes one or more devices which can transmit or receive at an instantaneous or overall occupied bandwidth of 100 MHz or more or have a data transmission rate of 100 Megabits per second or more at least one of said one or more devices have higher quality of**

transmission or reception than if said repeater or relay was not present in said network.

Ganz/Larrick discloses this limitation. (EX1002, ¶¶131-133.) Ganz explains that its quality of service (QoS) software module “includes bandwidth management functions that provide traffic control of the WBCR, allowing improved network performance while enforcing traffic flows and other network policies.” (EX1005, 10:52-54.) The QoS module uses “prioritization of data,” in order to “distinguish between time-sensitive traffic and non-time sensitive traffic and to give the former higher priority.” (EX1005, 11:5-7.) For example, “[t]he successful deployment of real-time applications such as voice and video may require that the WBCR provide a specific QoS for different applications.” (EX1005, 11:14-17.) Thus, Ganz discloses that its WBCR optimizes the quality of transmission or reception to user devices, and said devices have a higher quality of transmission or reception than if the WBCR was not present in the network. (EX1002, ¶132.)

Ganz does not expressly disclose that its transmitter/receiver is configured for receiving wireless data through signals that have an occupied bandwidth of 100MHz or more. However, Larrick discloses a receiver using the claimed bandwidth and as discussed above, a POSITA would have been motivated to combine Ganz and Larrick. *See* claim 1[e] above. (EX1002, ¶133.)

8. Claim 9: The broadband wireless repeater or relay of claim 1 wherein said repeater or relay is configured such that

when in a network which includes one or more devices which can transmit or receive at an instantaneous or overall occupied bandwidth of 100 MHz or more or have a data transmission rate of 100 Megabits per second or more at least one of said one or more devices has less interference than if said repeater or relay was not present in said network.

Ganz/Larrick discloses this limitation. (EX1002, ¶¶134-135.) Ganz discloses that its WCBR contains a “radio/data link element,” which “preferably employs spread spectrum transmission, either using frequency hopping or direct sequence coding schemes,” which “*decreases the chances of radio frequency jamming/interference, detection and interception of radio frequencies and provides for the capability of encryption.*” (EX1005, 7:6-11; EX1002, ¶134.)

Ganz does not expressly disclose that its transmitter/receiver is configured for receiving wireless data through signals that have an occupied bandwidth of 100MHz or more. However, Larrick discloses a receiver using the claimed bandwidth and as discussed above, a POSITA would have been motivated to combine Ganz and Larrick. *See* claim 1[e] above. (EX1002, ¶135.)

- 9. Claim 10: The broadband wireless repeater or relay of claim 1 wherein said repeater or relay is configured such that when in one or more wireless networks which includes one or more devices which can transmit at an instantaneous or overall occupied bandwidth of 100 MHz or more or have a data transmission rate of 100 Megabits per second or more at least one of said one or more wireless networks has an improved ability to control its capacity than if said**

repeater or relay was not present in said one or more wireless networks.

Ganz/Larrick discloses this limitation. (EX1002, ¶¶136-137.) Ganz explains that “[t]he WBCR may also be segregated into multiple tiers or layers when a segment on a user end approaches capacity.” (EX1005, 5:33-34.) Thus, “[i]f there is a high volume of users that significantly exceed a 2-5% loading factor, separate segments may be dedicated to the users.” (EX1005, 5:34-37.) Depending on the specific application, segregation can be accomplished at the radio datalink level by: “(1) assigning another spread spectrum chip code to that link, thereby providing isolation from other radios on the network; (2) operating a new segment on a different radio frequency; and (3) attaching directionally controlled antennas to the radios, thereby providing for spatial diversity.” (EX1005, 5:40-46.) Thus, a POSITA would understand that a network implementing Ganz’s WBCR would have an improved ability to control its capacity. (EX1002, ¶136.)

Ganz does not expressly disclose that its transmitter/receiver is configured for receiving wireless data through signals that have an occupied bandwidth of 100MHz or more. However, Larrick discloses a receiver using the claimed bandwidth and as discussed above, a POSITA would have been motivated to combine Ganz and Larrick. *See* claim 1[e] above. (EX1002, ¶137.)

10. Claim 11: The broadband wireless repeater or relay of claim 1 wherein said signals or data received by said

receiver or transceiver for receiving signals or data, or signals or data transmitted by said transmitter or transceiver for transmitting signals or data, or signals or data controlled by said controller include modified, stored, or delayed signals or data.

Ganz/Larrick discloses this limitation. (EX1002, ¶¶138-139.) Ganz discloses a “computer circuit 156” that contains the “processor 160,” the “RAM circuit 158,” and the “ROM circuit 162.” When information is received by the WBCR, “the data packets coming from the user side, are received by the second radio transceiver circuit 140 and then *temporarily buffered in the RAM circuit 158* before being retransmitted by the radio transceiver circuit 4 to the host radio station.” (EX1005, 4:22-26, FIG. 2; EX1002, ¶138.)

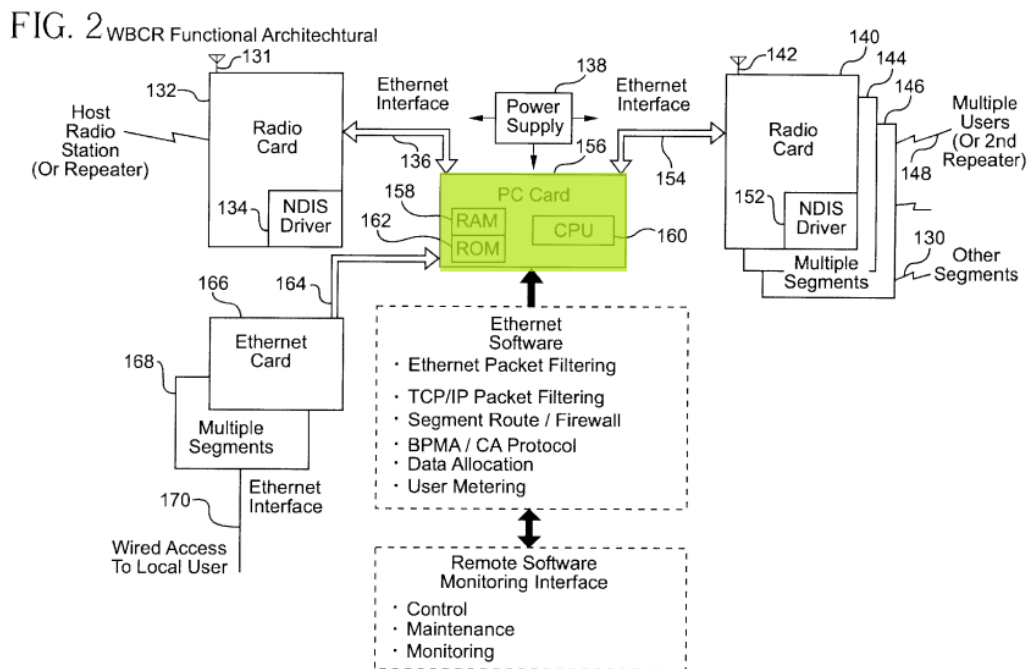

Ganz further discloses a “cache” within its software modules, which keeps

“popular” data locally, thereby “reduc[ing] the overall requirements for remote backbone bandwidth.” Further, (EX1005, 11:52-64.) Further, “[t]he WBCR can communicate cache information with its neighbors via the RFC 2186 internet cache protocol, thus a distributed object cache can flow throughout the local network instead of being limited to a single node.” *Id.* Thus, a POSITA would understand that Ganz discloses controlling modified, stored, or delayed signals or data. (EX1002, ¶139.)

11. **Claim 12: The broadband wireless repeater or relay of claim 1 wherein said controller is configured to cause said at least one transmitter or transceiver for transmitting signals or data to transmit modified received data or transmissions to one or more devices at an instantaneous or overall occupied bandwidth of 100 MHz or more or have a data transmission rate of 100 Megabits per second or more.**

Ganz/Larrick discloses this limitation. (EX1002, ¶140.) *See* claim limitation 1[e] above.

12. **Claim 13: The broadband wireless repeater or relay of claim 1 wherein said controller is configured to identify one or more devices in said one or more wireless networks.**

Ganz/Larrick discloses this limitation. (EX1002, ¶141.) Ganz describes, as part of its capacity management processes, that “[t]he WBCR may also be segregated into multiple tiers or layers when a segment on a user end approaches capacity.” (EX1005, 5:33-46.) This is accomplished with the use of “additional radio transceiver circuits on the user side of the WBCR, *each with its own unique*

IP address, Ethernet and radio ID code.” (*Id.*) Ganz further describes that basic maintenance functions for ensuring efficient network utilization can be performed remotely, such as “adding new users and *user ID’s*, and updating user priority codes.” (EX1005, 5:58-60.) Thus, Ganz describes that its WBCR is able to identify one or more devices in the network. (EX1002, ¶141.)

13. Claim 15: The broadband wireless repeater or relay of claim 1 wherein said controller is self-configurable.

Ganz/Larrick discloses this limitation. (EX1002, ¶142.) Ganz describes its “dynamic host configuration protocol (DHCP) circuit,” which “allows users to take a personal computer (PC) or a workstation and plug it into a DHCP enabled network.” (EX1005, 10:24-27.) This provides “all the necessary addresses, masks, default gateways, etc., allocated to them automatically *without any end user intervention*. The DHCP simplifies the administration of IP addresses for local networks.” (EX1005, 10:27-31.) Thus, Ganz describes that its invention is self-configurable. (EX1002, ¶142.)

14. Claim 20: The broadband wireless repeater or relay of claim 1 wherein said controller performs b).

For the reasons discussed above in limitation 1[f], Ganz/Larrick discloses this limitation. (EX1002, ¶143.)

15. Claim 21: The broadband wireless repeater or relay of claim 1 wherein said repeater or relay is configured to be integrated with or in communication with a device selected

from the group consisting of a television, a telephone, a cellphone, a computer, a camera, a video system, a monitor, a power plug, a wall outlet, a watch, a cable modem, a vehicle or other moving platform, a game console, and an ultrawideband transceiver or device.

Ganz/Larrick discloses this limitation. (EX1002, ¶¶144-145.) Ganz describes that “[t]he management software 230, provides for remote administration. Remote administration of the WBCR is possible by a high level encryption scheme and secure ports. Security keys are generated on a regular time period (e.g. every 60 minutes) to ensure that no key is active long enough to be broken. Initial keys are exchanged by an encrypted password, so that no passwords appear in clear-text on any network.” (EX1005, 11:65-12:5; EX1002, ¶144.).

A POSITA would understand that “management software” which “provides for remote administration” would include an interface accessible from a remote computer. (EX1002, ¶145.) A POSITA would understand that in order to provide remote administration, the management software would provide an interface for the remote administrator to perform the administrative tasks. (EX1002, ¶145.) Such an interface would be accessible from a remote computer. (EX1002, ¶145.)

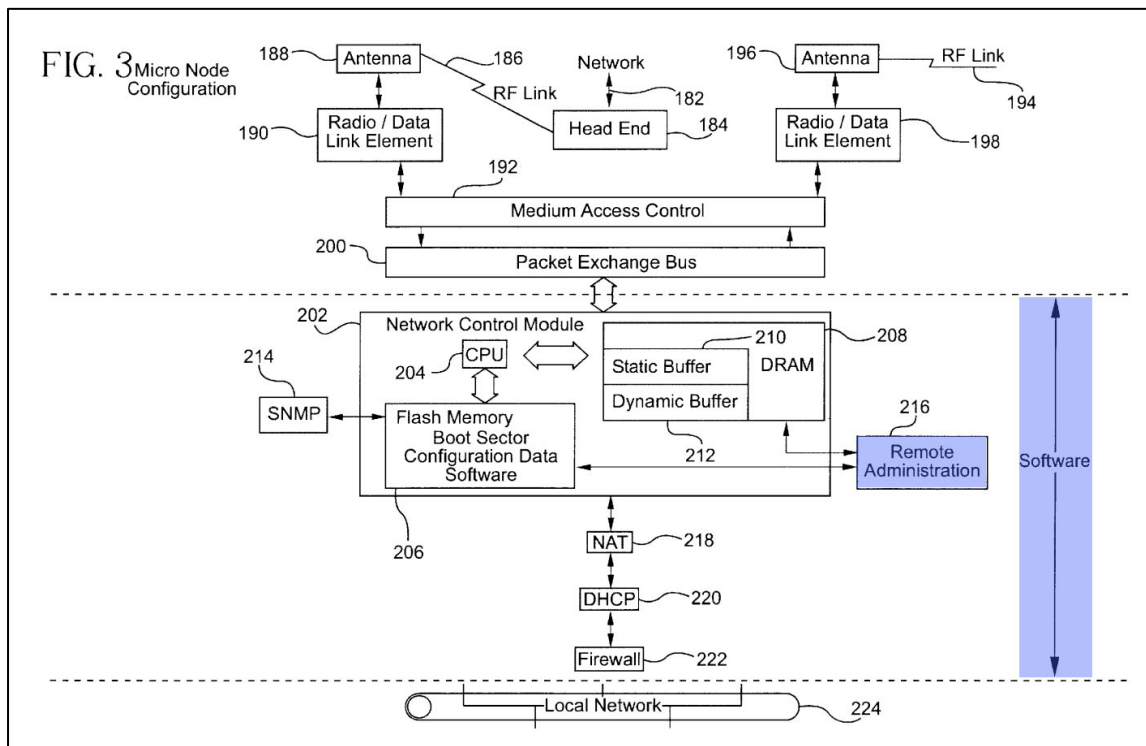

16. **Claim 22: The broadband wireless repeater or relay of claim 1 wherein one or more of said receiver or transceiver for signal or data reception, said transmitter or transceiver for signal or data transmission, and said controller is embedded in one or more integrated circuit chips.**

Ganz/Larrick discloses this limitation. (EX1002, ¶¶146-147.) Larrick’s FIG. 16, which is “a photograph of a circuit board of a transceiver utilizing the present invention” (EX1007; 9:7-8) “shows the UWB receiver imbedded in a full duplex, voice/data ultra wideband transceiver. The RF section of this particular unit (lower left hand side) is wideband from a few MHz to beyond 4 GHz. Tunnel diodes with adequate response characteristics to 26 GHz and beyond are currently available, and thus the UWB receiver can readily accommodate a wide variety of center

frequencies between a few MHz upwards toward 26 GHz.” (*Id.*; 21:54-61; EX1002, ¶146.)

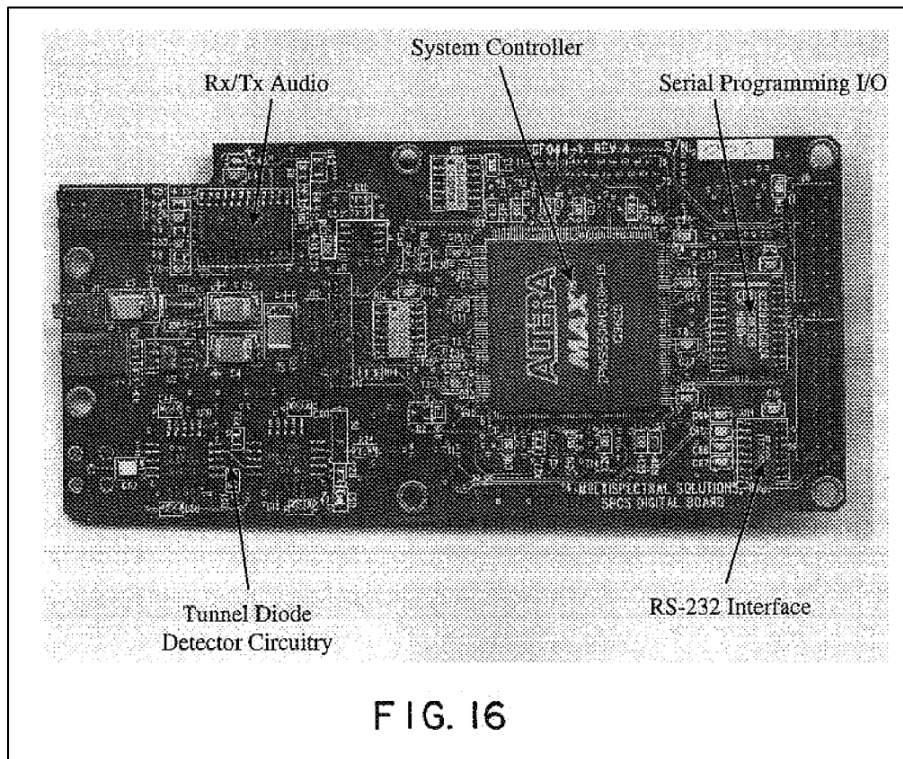

Thus, Larrick discloses that its controller is embedded in an integrated circuit chip. (EX1002, ¶147.)

17. Claim 23: The broadband wireless repeater or relay of claim 1 wherein said controller performs c).

Ganz/Larrick discloses this limitation. (EX1002, ¶148.) Ganz describes software controlled radio/data communications that perform “*[m]onitoring and control of the WBCR.*” (EX1005, 5:47-48.) As such, “[t]hroughput speeds and data packet drop rates can be measured periodically and corrective steps taken to adjust the radio parameters remotely.” (EX1005, 5:51-54.) “The controlling functions

implemented as part of the BPMA/CA protocol provide for remote dynamic load balancing among the users, and individually enhancing or reducing the allowable user packet size requests, thereby ensuring efficient network utilization for all users.” (EX1005, 5:54-58.) Additionally, “[b]asic maintenance functions are performed remotely as well, such as adding new users and user ID's, and updating user priority codes.” (EX1005, 5:58-61). Thus, a POSITA would understand that Ganz discloses that its controller performs network provisioning or monitoring. (EX1002, ¶148.)

- 18. Claim 24: The broadband wireless repeater or relay of claim 1 wherein in c) includes one or more of: i) bandwidth or delay provisioning of repeated or relayed transmissions, ii) application prioritization, iii) prioritizing, delaying or altering of data transmissions, traffic, or bandwidth, and iv) monitoring or measuring traffic from one or more devices, users or networks.**

Ganz/Larrick discloses this limitation. (EX1002, ¶¶149-151.)

For example, Ganz discloses QoS software that “includes bandwidth management functions that provide traffic control of the WBCR, allowing improved network performance while enforcing traffic flows and other network policies.” (EX1005, 10:52-54.) These QoS functions include prioritization, which “provides the WBCR with the flexibility to distinguish between time-sensitive traffic and non-time sensitive traffic and to give the former higher priority. A typical prioritization scheme assigns an administratively defined priority to each packet and then forwards

the packet to a high, medium, or low priority queue.” (EX1005, 11:5-9; EX1002, ¶150.)

Additionally, Ganz describes the software function of “load balancing” to “ensure efficiency of data transfer in the WBCR.” (EX1005, 12:12-21.) According to Ganz, “[t]he total bandwidth available to any single WBCR is limited only by the number of connections it has to other segments of the network. Since each individual link has an available bandwidth that is typically smaller than the backbone connectivity for the network as a whole, *a load balancing mechanism is used for optimizing the total system throughput.* This allows the creation of bandwidth on demand, *by routing excess traffic through links that would otherwise be underutilized.*” (EX1005, 12:12-21; EX1002, ¶151.)

19. Claim 25: The broadband wireless repeater or relay of claim 1 wherein said broadband wireless repeater or relay is configured or configurable for monitoring or measuring traffic passed through, received by or transmitted by said broadband wireless repeater or relay.

Ganz/Larrick discloses this limitation. (EX1002, ¶152.) Ganz describes software controlled radio/data communications that perform “*[m]onitoring and control of the WBCR.*” (EX1005, 5:47-48.) As such, “[t]hroughput speeds and data packet drop rates can be measured periodically and corrective steps taken to adjust the radio parameters remotely.” (EX1005, 5:51-54.) “The controlling functions implemented as part of the BPMA/CA protocol provide for remote dynamic load

balancing among the users, and individually enhancing or reducing the allowable user packet size requests, thereby ensuring efficient network utilization for all users.” (EX1005, 5:54-58.) Additionally, “[b]asic maintenance functions are performed remotely as well, such as adding new users and user ID's, and updating user priority codes.” (EX1005, 5:58-61.) Thus, a POSITA would understand that Ganz discloses that its WBCR is configurable for monitoring or measuring traffic that passes through it. (EX1002, ¶152.)

20. Claim 26: The broadband wireless repeater or relay of claim 1 wherein said broadband wireless repeater or relay is configured or configurable to modify at least some received signals or data from one or more devices, users or networks and transmit modified or delayed signals or data to at least one device, network or user via wireless communication.

Ganz/Larrick discloses this limitation. (EX1002, ¶¶153-154.) Ganz discloses sending modified or delayed signals or data as discussed above for Claim 11. (EX1002, ¶¶153-154.)

Additionally, Ganz discloses that these signals can be sent wirelessly. (EX1002, ¶154.) For example, Ganz is directed to a “wireless high speed data communication system,” in which a host radio station transmits data to a wireless communication repeater, which communicates with at least one end user. “The host radio station transmits and receives data to and from at least one wireless communication repeater within line of sight of the host radio station,” thus

communicating wirelessly, and “[t]he repeater is configured to communicate with at least one end user by *either a direct electrical connection or a wireless connection.*” (EX1005, 2:46-50.) Thus, Ganz discloses sending modified or delayed signals or data via wireless communication. (EX1002, ¶154.)

VIII. Ground 2: Ganz and Larrick in Combination with Engels Renders Claims 14 and 19 Obvious

A. Overview and Motivation to Combine

Engels teaches various conventional antenna technologies that were well-known, including MIMO, beamforming, adaptable, and directional antennas. (EX1002, ¶155.)

A POSITA would have been motivated to incorporate the teachings of Engels to improve the Ganz system (along with its combination with Larrick) because of the utility of MIMO, beamforming, adaptable, and directional antennas. (EX1002, ¶156.) Such technologies were conventional and well-known by the time of the ’754 patent, and a POSITA would have known and been motivated by their utility. (EX1002, ¶156.) It was known that MIMO could minimize errors, optimize data speed, and improve bandwidth and capacity by allowing data to travel over multiple signals at the same time. In particular, MIMO would transmit multiple signals along multiple paths, allowing better SNR performance in challenging conditions. (EX1002, ¶156.)

Beamforming is a signal processing technique used in wireless communications (Wi-Fi, 5G, radar, sonar, etc.) that focuses a signal in a specific direction instead of broadcasting it equally in all directions. (EX1002, ¶157.) Beamforming uses adaptable and steerable antennas. (EX1002, ¶157.) A POSITA would have been motivated to use beamforming as it allows for improved signal strength by directing energy to an intended receiver. (EX1002, ¶157.) This increases range and reduces dead zones, as well as allowing for higher data rates and reduction in interference. Moreover, beamforming allows multiple users to share the same frequency band simultaneously by steering beams in different directions (multi-user MIMO in 5G and Wi-Fi 6/7). Beamforming also increases energy efficiency by concentrating power where it's needed reduces overall wasted transmission energy. (EX1002, ¶157.)

A POSITA would have had a reasonable expectation of success combining Ganz-Larrick with Engels. (EX1002, ¶158.) MIMO and beamforming were well-known and conventional technologies. (EX1002, ¶158.) A POSITA would have been well aware of such methods and the conventional ways of implementing such standard technologies. Implementation would have been well-within the skill of an ordinary artisan. (EX1002, ¶158.)

B. Limitation-By-Limitation Analysis

- 1. Claim 14: The broadband wireless repeater or relay of claim 1 wherein said repeater or relay employs MIMO or adaptive antenna technology.**

Engles teaches that “the usage of *multiple antenna techniques* with antenna means (10) may result in a communication with antenna's at multiple outdoor nodes located at different locations.” (EX1008, 13:11-13; EX1002, ¶159.) These techniques, which are “particularly useful for providing redundancy in the outdoor connection,” include “beamforming, spatial division multiple access (SDMA), *multiple input multiple output (MIMO) systems.*” (EX1008, 13:13-15.) Engels therefore discloses that its network device could be configured for using MIMO antenna technology. (EX1002, ¶159.)

- 2. Claim 19: The broadband wireless repeater or relay of claim 1 wherein at least one of said receiver or transceiver for signal or data reception, at least one of said transmitter or transceiver for signal or data transmission, or said controller is configured for operation in at least one of said one or more wireless networks selected from the group consisting of: a cellular network, an enterprise network, a wireless local area network, or a wireless personal area network.**

Engels discloses that its teachings “relate[] to communication between indoor and outdoor environments, especially making use of wireless radio telecommunication networks” which include known cellular technologies such as “CDMA, FDMA, TDMA ...” (EX1008, 7:12-16; EX1002, ¶160.)

IX. Ground 3: Ganz and Larrick in Combination with Perlman Renders Claims 7 and 15-18 Obvious

A. Overview and Motivation to Combine

Perlman teaches various conventional repeater techniques that were well-known, including using repeaters to increase the coverage distance of the network, to obtain coverage in indoor, outdoor, and moving environments, and to make a repeater self-configurable. (EX1002, ¶161.)

A POSITA would have been motivated to incorporate the teachings of Perlman to improve the Ganz system (along with its combination with Larrick). (EX1002, ¶162.) Both Ganz and Perlman address repeater systems that aimed to address known limitations and problems of wireless technologies at the time. A POSITA would have sought to further improve Ganz by applying the teachings of Perlman because of the utility of increasing the coverage distance of the network, obtaining coverage in indoor, outdoor, and moving environments, and making a repeater self-configurable. (EX1002, ¶162.) Such technologies were conventional and well-known by the time of the '754 patent, and a POSITA would have known and been motivated by their utility. (EX1002, ¶162.)

It was a well-known problem that transmission of high-bandwidth data could be degraded by “structural obstacles,” “human traffic,” “conflicting devices,” as well as “distance between the access point and the mobile terminal or other device.”

(EX1011, [0006]; EX1002, ¶163.) The concept of using wireless repeaters to extend coverage throughout a building similarly existed at the time. (EX1011, [0008]; EX1002, ¶163.) Perlman applies these concepts in its teachings towards a system that utilizes wireless repeaters to solve these problems, increasing the network coverage distance and making it useful in moving, indoor, and outdoor environments. (EX1002, ¶163.) Perlman similarly applies known concepts of making its repeaters self-configurable to provide convenience to the user, negating the need to manually configure each repeater. (EX1002, ¶163.)

A POSITA would have had a reasonable expectation of success combining Ganz-Larrick with Perlman. (EX1002, ¶164.) Perlman utilizes a combination of known techniques to improve the performance of known repeater technologies. A POSITA would have been well aware of such methods and the conventional ways of implementing such standard technologies. (EX1002, ¶164.) Implementation would have been well-within the skill of an ordinary artisan. (EX1002, ¶164.)

B. Limitation-By-Limitation Analysis

- 1. Claim 7: The broadband wireless repeater or relay of claim 1 wherein said repeater or relay is configured such that when in a network which includes one or more devices which can transmit or receive at an instantaneous or overall occupied bandwidth of 100 MHz or more or have a data transmission rate of 100 Megabits per second or more at least one of said one or more devices has a greater coverage**

distance than if said repeater or relay was not present in said network.

Perlman discloses this claim. (EX1002, ¶¶165-166.) For example, Perlman identifies the problem of degradation of high-bandwidth data transmissions “by the physical distance between the access point and the mobile terminal or other device.” (EX1011, [0006]; EX1002, ¶165.) To address this, Perlman’s system “achieves *full range coverage in the home without bandwidth loss* by utilizing a different channel for each data packet hop. This feature allows repeater data packets to overlap in time...” (EX1011, [0059]; EX1002, ¶165.) Thus, Perlman teaches use of a repeater that is configured such that when in a network at least one of said one or more devices has a greater coverage distance than if the repeater was not present in said network. (EX1002, ¶165.)

Perlman does not expressly disclose that its transmitter/receiver is configured for receiving wireless data through signals that have an occupied bandwidth of 100MHz or more. However, Larrick discloses a receiver using the claimed bandwidth and as discussed above, a POSITA would have been motivated to combine Perlman and Ganz/Larrick. *See* claim 1[e] above. (EX1002, ¶166.)

2. Claim 15: The broadband wireless repeater or relay of claim 1 wherein said controller is self-configurable.

Perlman discloses a wireless network architecture that is self-configurable. (EX1002, ¶¶167-168.) For example, Perlman describes that “[t]he *self-configuring*

feature of the present invention is also apparent...” (EX1011, [0086]; EX1002, ¶167.) This is done by “a processor in the source access point” that “executes a program or algorithm that determines an optimal set of frequency channels allocated for use by each access point or repeater.” (EX1011, [0086].) Optimal sets of channels are ones that “do not include over-lapping channels,” “avoid[] channels used by other interfering devices in the same locality,” and “maximize[] channel re-use.” (*Id.*) Further, once a set of the channels has been chosen for use by the access points, “modulated power can be reduced to the minimum needed to achieve maximum bandwidth across each link so as to reduce signal reflections.” (*Id.*) Further, Perlman describes that its wireless network “may also adapt to changes to the network by reconfiguring the channel assignments, such as when new repeaters are added, existing ones removed, or when the network experiences disturbances caused by other interfering devices (e.g., from a neighboring network).” (*Id.*; EX1002, ¶168.)

Perlman further describes an “adaptation process” similar to the self-configuration process described above, where “all of the different possible combinations of channels may be tried until the network identifies an optimal combination that works to overcome the channel conflict without creating any new conflicts.” (EX1011, [0094].) In doing so, “[t]he adaptation process may rely upon an algorithm that does not attempt to change or move channels which have already been established.” (*Id.*) Thus, “regardless of the origin of a channel conflict”

Perlman's disclosed network "adapts to the disturbance by *reconfiguring itself* to optimize performance." (*Id.*; EX1002, ¶168.)

3. Claim 16: The broadband wireless repeater or relay of claim 1 wherein at least one of said receiver or transceiver for signal or data reception, at least one of said transmitter or transceiver for signal or data transmission, or said controller is configured for operation in at least one of said one or more wireless networks in a moving platform environment.

Perlman discloses this claim. (EX1002, ¶¶169-170.) Perlman describes that its invention has the ability to "provide connectivity to any user who happens to be within the range of the wireless network." (EX1011, [0106].) For example, if "a wireless repeater or access point is mounted near a window or on the rooftop of a building," a user with a laptop computer that is within range could connect to the Internet. (*Id.*) Thus, Perlman explains that its invention "provides ever greater mobility by allowing portable computer users to take media content with them." (*Id.*) A POSITA would understand that Perlman thereby allows operation of its network in a moving platform environment, whereby users on mobile or portable devices can connect to the network from different locations. (EX1002, ¶¶169-170.)

Perlman does not expressly disclose that its transmitter/receiver is configured for receiving wireless data through signals that have an occupied bandwidth of 100MHz or more. However, Larrick discloses a receiver using the claimed bandwidth and as discussed above, a POSITA would have been motivated to

combine Perlman and Ganz/Larrick. See claim 1[e] above. (EX1002, ¶170.)

4. **Claim 17: The broadband wireless repeater or relay of claim 1 wherein at least one of said receiver or transceiver for signal or data reception, at least one of said transmitter or transceiver for signal or data transmission, or said controller is configured for operation in at least one of said one or more wireless networks in an indoor environment.**

Perlman discloses this claim. (EX1002, ¶¶171-172.) Perlman describes many applications of its network in indoor environments. For example, FIG. 19 is “a floor plan showing two simultaneous wireless networks operating *in a building* 84 to increase bandwidth.” (EX1011, [0098]; EX1002, ¶171.)

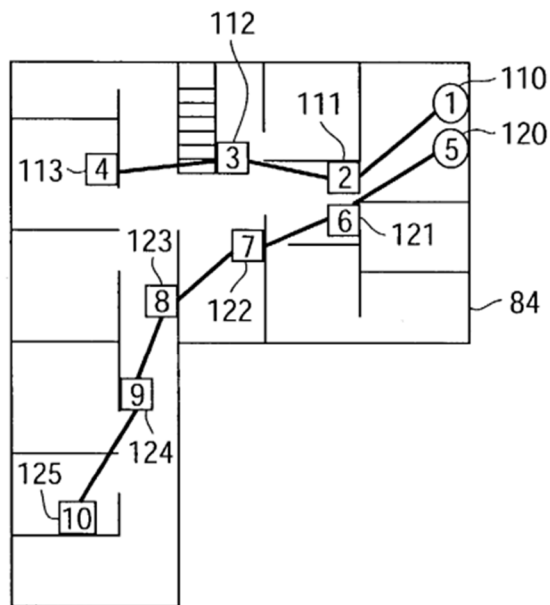

FIG. 19

Perlman does not expressly disclose that its transmitter/receiver is configured for receiving wireless data through signals that have an occupied bandwidth of

100MHz or more. However, Larrick discloses a receiver using the claimed bandwidth and as discussed above, a POSITA would have been motivated to combine Perlman and Ganz/Larrick. *See* claim 1[e] above. (EX1002, ¶172.)

5. Claim 18: The broadband wireless repeater or relay of claim 1 wherein at least one of said receiver or transceiver for signal or data reception, at least one of said transmitter or transceiver for signal or data transmission, or said controller is configured for operation in at least one of said one or more wireless networks in an outdoor environment.

Perlman discloses this claim. (EX1002, ¶¶173-174.) Perlman describes that its invention has the ability to “provide connectivity to any user who happens to be within the range of the wireless network.” (EX1011, [0106]; EX1002, ¶173.) For example, if “a wireless repeater or access point is mounted near a window or on the rooftop of a building, *the outdoor range of the wireless network may be extended to a nearby park or other buildings* (e.g., a café or coffeehouse).” (*Id.*) A user with a laptop computer that is within range could thereby connect to the Internet outdoors. (*Id.*)

Perlman does not expressly disclose that its transmitter/receiver is configured for receiving wireless data through signals that have an occupied bandwidth of 100MHz or more. However, Larrick discloses a receiver using the claimed bandwidth and as discussed above, a POSITA would have been motivated to combine Perlman and Ganz/Larrick. *See* claim 1[e] above. (EX1002, ¶174.)

X. CONCLUSION

For at least the foregoing reasons, this Petition should be instituted.

Respectfully submitted,

Date: September 29, 2025

/s/ James M. Glass

James M. Glass (Reg. No. 46729)
QUINN EMANUEL URQUHART &
SULLIVAN LLP
295 5th Avenue, 9th Floor
New York, NY 10016
Email: jimglass@quinnemanuel.com
Phone: 212-849-7142
Fax: 212-849-7100

CERTIFICATION UNDER 37 C.F.R. § 42.24

Under the provisions of 37 C.F.R. § 42.24, the undersigned hereby certifies that the word count for the foregoing Petition for *inter partes* review (excluding the table of contents, table of authorities, mandatory notices, certificate of service or word count, and appendix of exhibits or claim listing) totals 10,500 words, which is within the word limit allowed under 37 C.F.R. § 42.24(a)(i.)

Date: September 29, 2025

/s/ James M. Glass

James M. Glass (Reg. No. 46729)
QUINN EMANUEL URQUHART &
SULLIVAN LLP
295 5th Avenue, 9th Floor
New York, NY 10016
Email: jimglass@quinnemanuel.com
Phone: 212-849-7142
Fax: 212-849-7100

CERTIFICATE OF SERVICE

Pursuant to 37 C.F.R. §§ 42.6(e), 42.105(a), the undersigned hereby certifies service on the PO of a copy of this Petition and its respective exhibits at the official correspondence address for the attorneys of record for the '754 patent as shown in USPTO PAIR via FedEx:

30743 - WC&F IP
11491 SUNSET HILLS ROAD, SUITE 340
RESTON, VA 20190
UNITED STATES

Courtesy copies were also sent via FedEx and electronic mail to Patent

Owner's counsel of record in the related district court proceeding:

Patrick J. McElhinny
K&L Gates LLP
210 Sixth Avenue
Pittsburgh, Pennsylvania 15222
Email: patrick.mcelhinny@klgates.com

Mark Knedeisen
Email: mark.knedeisen@klgates.com

Christopher Verdini
Email: christopher.verdini@klgates.com

Anna Shabalov
Email: anna.shabalov@klgates.com

Rachel Ellenberger
Email: rachel.ellenberger@klgates.com

Andrea L. Fair
MILLER FAIR HENRY PLLC

1507 Bill Owens Parkway
Longview, Texas 75604
E-mail: andrea@millerfairhenry.com

Date: September 30, 2025

/s/ James M. Glass

James M. Glass (Reg. No. 46,729)
QUINN EMANUEL URQUHART &
SULLIVAN LLP
295 5th Avenue, 9th Floor
New York, NY 10016
Email: jimglass@quinnemanuel.com
Phone: 212-849-7142
Fax: 212-849-7100