

UNITED STATES PATENT AND TRADEMARK OFFICE

BEFORE THE PATENT TRIAL AND APPEAL BOARD

SAMSUNG ELECTRONICS CO., LTD.,
SAMSUNG ELECTRONICS AMERICA, INC.
Petitioner,

v.

MASSIVELY BROADBAND, LLC,
Patent Owner.

CASE: IPR2025-01595
U.S. PATENT NO. 8,923,754

PATENT OWNER'S PRELIMINARY RESPONSE

TABLE OF CONTENTS

	Page
I. INTRODUCTION	1
II. STATEMENT OF THE PRECISE RELIEF REQUESTED.....	3
III. BACKGROUND	3
A. Summary of the '754 Patent.....	3
B. Priority Date	5
C. Level of Ordinary Skill.....	5
D. Claim Construction.....	6
E. The Petition's Asserted Grounds.....	6
1. Grounds Asserted in the Petition	6
2. Summary of the Asserted Grounds' Prior Art	7
IV. THE PETITION FAILS TO ESTABLISH A REASONABLE LIKELIHOOD OF SUCCESS ON A SINGLE CLAIM	9
A. Petitioner Fails to Articulate Its Obviousness Grounds with Particularity. 11	
1. The Petition Does Not Assert a Coherent Theory for Combining Ganz and Larrick.....	12
2. The Petition Does Not Articulate a Coherent Obviousness Theory for Ground 1	14
3. The Petition Fails to Articulate Any Motivation to Combine With Particularity.....	19
4. Grounds 2 and 3 Fail for the Same Lack of Particularity as Ground 1....	20
B. Petitioner's Motivation to Combine Ganz and Larrick Lacks Rational Underpinning	20
C. Petitioner's Expert Declaration Does Not Cure the Deficiencies in the Petition	23
V. CONCLUSION.....	26

TABLE OF AUTHORITIES

	Page(s)
Cases	
<i>Arendi S.A.R.L. v. Apple, Inc.</i> , 832 F.3d 1355 (Fed. Cir. 2016)	10
<i>Cisco Systems, Inc. v. C-Cation Techs., LLC</i> , IPR2014-00454, Paper 12 (PTAB Aug. 29, 2014).....	23
<i>Dish Network L.L.C. v. TQ Beta, LLC</i> , IPR2015-01791, Paper 30 (PTAB Jan. 30, 2017)	9
<i>Harmonic Inc. v. Avid Tech., Inc.</i> , 815 F.3d 1356 (Fed. Cir. 2016)	<i>passim</i>
<i>Hunting Titan, Inc. v. DynaEnergetics Europe GmbH</i> , PGR2020-00080, Paper 7 (PTAB Feb. 12, 2021)	9
<i>Innogenetics, N.V. v. Abbott Lab 'ys.</i> , 512 F.3d 1363 (Fed. Cir. 2008)	19, 21
<i>InTouch Techs., Inc. v. VGO Commc 'ns, Inc.</i> , 751 F.3d 1327 (Fed. Cir. 2014)	10
<i>In re Kahn</i> , 441 F.3d 977 (Fed. Cir. 2006)	20
<i>KSR Int'l Co. v. Teleflex, Inc.</i> , 550 U.S. 398 (2007).....	9, 20, 21
<i>In re Magnum Oil Tools Int'l, Ltd.</i> , 829 F.3d 1364 (Fed. Cir. 2016)	26
<i>Netflix, Inc. v. DivX, LLC</i> , 84 F.4th 1371 (Fed. Cir. 2023)	14
<i>In re Nuvasive, Inc.</i> , 842 F.3d 1376 (Fed. Cir. 2016)	10

Procter & Gamble Co. v. Teva Pharm. USA, Inc.,
566 F.3d 989 (Fed. Cir. 2009)10

Redline Detection, LLC v. Star Envirotech, Inc.,
811 F.3d 435 (Fed. Cir. 2015)26

In re Rouffet,
149 F.3d 1350 (Fed. Cir. 1998)20

TQ Delta, LLC v. CISCO Sys., Inc.,
942 F.3d 1352 (Fed. Cir. 2019)2, 21, 22

Upjohn Co. v. Mova Pharm. Corp.,
225 F.3d 1306 (Fed. Cir. 2000)23

Virtek Vision Int’l ULC v. Assembly Guidance Sys., Inc.,
97 F.4th 882 (Fed. Cir. 2024)2

Statutes

35 U.S.C. § 312(a)(3).....*passim*

Other Authorities

37 C.F.R. § 42.65(a).....23, 25

37 C.F.R. § 42.104(b)(4).....1, 9, 11, 22

37 C.F.R. § 42.107(a).....1

TABLE OF EXHIBITS

Exhibit No.	Description
2001	Complaint for Patent Infringement, Dkt. 1, <i>MASSIVELY BROADBAND LLC v. Samsung Elecs. Co. Ltd.</i> , No. 2:25-cv-00608-JRG (E.D. Tex. June 6, 2025)
2002	Quitclaim Assignment from Theodore S. Rappaport to MASSIVELY BROADBAND LLC, Dec. 31, 2024
2003	Texas A&M Hagler Institute for Advanced Study, Dr. Theodore (Ted) S. Rappaport, Class of 2024-25, hias.tamu.edu/fellow/dr-theodore-ted-s-rappaport/ (retrieved Oct. 22, 2025)
2004	Transcript of Pioneer Award Presentation, 2022 Brooklyn 6G Wireless Summit, April 27, 2022, available at ieeetv.ieee.org/channels/communications/pioneer-award-tom-wheeler-2022-b6gs-virtual
2005	National Academy for Engineering, Dr. Theodore S. Rappaport, www.nae.edu/250163/Dr-Theodore-Scott-Rappaport (retrieved Oct. 20, 2025)
2006	“NYU Professor Theodore S. Rappaport named to Wireless Hall of Fame,” July 25, 2019, www.prnewswire.com/news-releases/nyu-professor-theodore-s-rappaport-named-to-wireless-hall-of-fame-300891117.html (retrieved Oct. 20, 2025)
2007	“WNCG Awarded NSF Industry Collaboration Center,” Feb. 2, 2011, www.ece.utexas.edu/news/wncg-awarded-nsf-industry-collaboration-center (retrieved Oct. 20, 2025)
2008	“InterDigital Joins NYU WIRELESS as an Industrial Affiliate,” Oct. 8, 2012, engineering.nyu.edu/news/interdigital-joins-nyu-wireless-industrial-affiliate (retrieved Oct. 20, 2025)

Exhibit No.	Description
2009	“Samsung Research America Joins NYU WIRELESS Industrial Affiliate Program,” Jan. 30, 2019, wireless.engineering.nyu.edu/samsung-research-america-joins-nyu-wireless-industrial-affiliate-program/ (retrieved Oct. 20, 2025)
2010	Defendants’ Answer to Plaintiff’s Complaint, Dkt. 16, <i>MASSIVELY BROADBAND LLC v. Samsung Elecs. Co. Ltd.</i> , No. 2:25-cv-00608-JRG (E.D. Tex. Sept. 29, 2025)
2011	PTAB Trial Statistics, 2025 End of Year Outcome Roundup, Patent Trial and Appeal Board, Fiscal Year 2025, available at www.uspto.gov/sites/default/files/documents/Trial_StatsFY25_Q4.pdf (last accessed Nov. 6, 2025)
2012	U.S. Patent 8,244,266
2013	T.S. Rappaport et al., “Millimeter Wave Mobile Communications for 5G Cellular: It Will Work!” IEEE Access, May 10, 2013, pp. 335-349.
2014	S. Hur et al., “Proposal on Millimeter-Wave Channel Modeling for 5G Cellular System,” IEEE J. Selected Topics Signal Processing, vol. 10, no. 3, April 2016, pp. 454-469.
2015	T.S. Rappaport et al., “Smart Antennas Could Open Up New Spectrum For 5G,” IEEE Spectrum, Aug. 28, 2014, spectrum.ieee.org/smart-antennas-could-open-up-new-spectrum-for-5g (retrieved Oct. 21, 2025)
2016	K. Haneda et al., “Indoor 5G 3GPP-like channel models for office and shopping mall environments,” 2016 IEEE International Conference on Communications Workshops (ICC), Kuala Lumpur, Malaysia, 2016, pp. 694-99

Exhibit No.	Description
2017	K. Haneda et al., “5G 3GPP-Like Channel Models for Outdoor Urban Microcellular and Macrocellular Environments,” 2016 IEEE 83rd Vehicular Technology Conference (VTC Spring), Nanjing, China, 2016, pp. 1-7
2018	First Amended Docket Control Order, Dkt. 25, <i>MASSIVELY BROADBAND LLC v. Samsung Elecs. Co.</i> , No. 2:25-cv-00608-JRG (E.D. Tex. Oct. 20, 2025)
2019	Lex Machina trial statistics for District Judge James Rodney Gilstrap, from Jan. 1, 2022 to Oct. 22, 2025.
2020	Defendants’ First Set of Interrogatories to Plaintiff, Oct. 21, 2025, <i>MASSIVELY BROADBAND LLC v. Samsung Elecs. Co.</i> , No. 2:25-cv-00608-JRG (E.D. Tex.)
2021	Oct. 21, 2025 Discovery Letter from Samsung, <i>MASSIVELY BROADBAND LLC v. Samsung Elecs. Co.</i> , No. 2:25-cv-00608-JRG (E.D. Tex.)
2022	Redline comparison of Petition’s text for Ground 1, Overview and Motivation to Combine and Limitation-by-Limitation Analysis of Claim 1 to corresponding text of Dr. Mahon’s declaration (Ex. 1002)
2023	Excerpts from T. Rappaport et al., <u>Millimeter Wave Wireless Communications</u> , Pearson Education, Inc., 2015
2024	U.S. Patent No. 11,863,340
2025	Declaration of Theodore S. Rappaport
2026	<i>MASSIVELY BROADBAND LLC v. Samsung Elecs. Co.</i> , No. 2:25-cv-00608-JRG, Dkt. 7 (E.D. Tex. June 25, 2025)
2027	<i>MASSIVELY BROADBAND LLC v. Samsung Elecs. Co.</i> , No. 2:25-cv-00608-JRG, Dkt. 24 (E.D. Tex. Oct. 15, 2025)

Exhibit No.	Description
2028	<i>MASSIVELY BROADBAND LLC v. Samsung Elecs. Co.</i> , No. 2:25-cv-00608-JRG, Dkt. 29 (E.D. Tex. Oct. 29, 2025)
2029	Samsung’s P.R. 3-3 and 3-4 Invalidation Contentions, Nov. 12, 2025, <i>MASSIVELY BROADBAND LLC v. Samsung Elecs. Co.</i> , No. 2:25-cv-00608-JRG (E.D. Tex.)
2030	Oct. 31, 2025 Discovery Letter from MBB, <i>MASSIVELY BROADBAND LLC v. Samsung Elecs. Co.</i> , No. 2:25-cv-00608-JRG (E.D. Tex.)
2031	Plaintiff’s First Set of Common Interrogatories to Defendants, Oct. 31, 2025, <i>MASSIVELY BROADBAND LLC v. Samsung Elecs. Co.</i> , No. 2:25-cv-00608-JRG (E.D. Tex.)
2032	’754 Patent Infringement Contentions, <i>Massively Broadband LLC v Samsung Electronics Co., Ltd., AND Samsung Electronics America, Inc.</i> , Case No. 2:25-cv-00698
2033	U.S. Patent No. 7,676,194
2034	RESERVED
2035	U.S. Patent No. 9,667,337
2036	U.S. Patent No. 10,224,999
2037	U.S. Patent No. 10,797,783
2038	U.S. Patent No. 8,350,763
2039	U.S. Patent No. 8,593,358
2040	U.S. Patent No. 11,063,625
2041	U.S. Patent No. 11,876,548
2042	U.S. Patent No. 8,224,794

Exhibit No.	Description
2043	U.S. Patent No. 8,515,925
2044	U.S. Patent No. 8,725,700
2045	Samsung's Notice of Subpoena <i>Duces Tecum</i> and <i>Ad Testificandum</i> to Apple Inc., Nov. 11, 2025, <i>MASSIVELY BROADBAND LLC v. Samsung Elecs. Co. Ltd. et al.</i> , No. 2:25-cv-00608-JRG (E.D. Tex.) (without Ex. C, Protective Order)
2046	Samsung's Notice of Subpoena <i>Duces Tecum</i> and <i>Ad Testificandum</i> to Blackberry Corp., Nov. 11, 2025, <i>MASSIVELY BROADBAND LLC v. Samsung Elecs. Co. Ltd. et al.</i> , No. 2:25-cv-00608-JRG (E.D. Tex.) (without Ex. C, Protective Order)
2047	Samsung's Notice of Subpoena <i>Duces Tecum</i> and <i>Ad Testificandum</i> to D-Link System Inc., Nov. 11, 2025, <i>MASSIVELY BROADBAND LLC v. Samsung Elecs. Co. Ltd. et al.</i> , No. 2:25-cv-00608-JRG (E.D. Tex.) (without Ex. C, Protective Order)
2048	Samsung's Notice of Subpoena <i>Duces Tecum</i> and <i>Ad Testificandum</i> to Netgear, Inc., Nov. 11, 2025, <i>MASSIVELY BROADBAND LLC v. Samsung Elecs. Co. Ltd. et al.</i> , No. 2:25-cv-00608-JRG (E.D. Tex.) (without Ex. C, Protective Order)
2049	Samsung's Notice of Subpoena <i>Duces Tecum</i> and <i>Ad Testificandum</i> to Ruckus Wireless LLC, Nov. 11, 2025, <i>MASSIVELY BROADBAND LLC v. Samsung Elecs. Co. Ltd. et al.</i> , No. 2:25-cv-00608-JRG (E.D. Tex.) (without Ex. C, Protective Order)
2050	Samsung's Notice of Subpoena <i>Duces Tecum</i> and <i>Ad Testificandum</i> to Sierra Wireless, Nov. 11, 2025, <i>MASSIVELY BROADBAND LLC v. Samsung Elecs. Co. Ltd. et al.</i> , No. 2:25-cv-00608-JRG (E.D. Tex.) (without Ex. C, Protective Order)

Exhibit No.	Description
2051	Samsung's Notice of Subpoena <i>Duces Tecum</i> and <i>Ad Testificandum</i> to Digital Envoy Inc., Nov. 12, 2025, <i>MASSIVELY BROADBAND LLC v. Samsung Elecs. Co. Ltd. et al.</i> , No. 2:25-cv-00608-JRG (E.D. Tex.) (without Ex. C, Protective Order)
2052	Samsung's Notice of Subpoena <i>Duces Tecum</i> and <i>Ad Testificandum</i> to Hewlett Packard Enterprise Co., Nov. 12, 2025, <i>MASSIVELY BROADBAND LLC v. Samsung Elecs. Co. Ltd. et al.</i> , No. 2:25-cv-000608-JRG (E.D. Tex.) (without Ex. C, Protective Order)
2053	Samsung's Notice of Subpoena <i>Duces Tecum</i> and <i>Ad Testificandum</i> to SOTI US Inc., Nov. 12, 2025, <i>MASSIVELY BROADBAND LLC v. Samsung Elecs. Co. Ltd. et al.</i> , No. 2:25-cv-00608-JRG (E.D. Tex.) (without Ex. C, Protective Order)
2054	Samsung's Notice of Subpoena <i>Duces Tecum</i> and <i>Ad Testificandum</i> to Green Dot, Corp., Nov. 12, 2025, <i>MASSIVELY BROADBAND LLC v. Samsung Elecs. Co. Ltd. et al.</i> , No. 2:25-cv-00608-JRG (E.D. Tex.) (without Ex. C, Protective Order)
2055	Samsung's Notice of Subpoena <i>Duces Tecum</i> and <i>Ad Testificandum</i> to HP Inc., Nov. 12, 2025, <i>MASSIVELY BROADBAND LLC v. Samsung Elecs. Co. Ltd. et al.</i> , No. 2:25-cv-00608-JRG (E.D. Tex.) (without Ex. C, Protective Order)
2056	Samsung's Notice of Subpoena <i>Duces Tecum</i> and <i>Ad Testificandum</i> to Open Mobile Alliance, Nov. 12, 2025, <i>MASSIVELY BROADBAND LLC v. Samsung Elecs. Co. Ltd. et al.</i> , No. 2:25-cv-00608-JRG (E.D. Tex.) (without Ex. C, Protective Order)
2057	Samsung's Notice of Subpoena <i>Duces Tecum</i> and <i>Ad Testificandum</i> to Omnissa, LLC, Nov. 12, 2025, <i>MASSIVELY BROADBAND LLC v. Samsung Elecs. Co. Ltd. et al.</i> , No. 2:25-cv-00608-JRG (E.D. Tex.) (without Ex. C, Protective Order)

Exhibit No.	Description
2058	Samsung's Notice of Subpoena <i>Duces Tecum</i> and <i>Ad Testificandum</i> to Verve Group, Inc., Nov. 12, 2025, <i>MASSIVELY BROADBAND LLC v. Samsung Elecs. Co. Ltd. et al.</i> , No. 2:25-cv-00608-JRG (E.D. Tex.) (without Ex. C, Protective Order)
2059	Samsung's Notice of Subpoena <i>Duces Tecum</i> and <i>Ad Testificandum</i> to Linksys USA, Inc., Nov. 12, 2025, <i>MASSIVELY BROADBAND LLC v. Samsung Elecs. Co. Ltd. et al.</i> , No. 2:25-cv-00608-JRG (E.D. Tex.) (without Ex. C, Protective Order)
2060	Samsung's Notice of Subpoena <i>Duces Tecum</i> and <i>Ad Testificandum</i> to Nokia of America Corp., Nov. 12, 2025, <i>MASSIVELY BROADBAND LLC v. Samsung Elecs. Co. Ltd. et al.</i> , No. 2:25-cv-00608-JRG (E.D. Tex.) (without Ex. C, Protective Order)
2061	Samsung's Notice of Subpoena <i>Duces Tecum</i> and <i>Ad Testificandum</i> to Cisco Systems, Inc., Nov. 12, 2025, <i>MASSIVELY BROADBAND LLC v. Samsung Elecs. Co. Ltd. et al.</i> , No. 2:25-cv-00608-JRG (E.D. Tex.) (without Ex. C, Protective Order)
2062	Samsung's Notice of Second Subpoena <i>Duces Tecum</i> and <i>Ad Testificandum</i> to Netgear, Inc., Nov. 17, 2025, <i>MASSIVELY BROADBAND LLC v. Samsung Elecs. Co. Ltd. et al.</i> , No. 2:25-cv-00608-JRG (E.D. Tex.) (without Ex. C, Protective Order)
2063	Samsung's Notice of Subpoena <i>Duces Tecum</i> and <i>Ad Testificandum</i> to SageNet LLC, Nov. 21, 2025, <i>MASSIVELY BROADBAND LLC v. Samsung Elecs. Co. Ltd. et al.</i> , No. 2:25-cv-00608-JRG (E.D. Tex.) (without Ex. C, Protective Order)
2064	Jan. 10, 2011 Office Action for Serial No. 11/977,603
2065	Patent No. 8,600,295
2066	April 19, 2019 Office Action for Serial No. 15/898,316
2067	U.S. Patent 10,523,258

I. INTRODUCTION

MASSIVELY BROADBAND LLC, (“Patent Owner”) submits this Patent Owner Preliminary Response pursuant to 37 C.F.R. § 42.107(a) to the *Inter Partes* Review petition (“Petition” or “Pet.”) filed by Samsung Electronics Co., Ltd. and Samsung Electronics America, LLC (“Petitioner”) for all twenty-six (26) claims (the “Challenged Claims”) of U.S. Patent 8,923,754 (the “’754 Patent”). The Board should deny the Petition because the Petition fundamentally fails to explain the motivation for the key combination of references upon which all asserted grounds in the Petition are based and, in fact, does not even explain with the requisite particularity how those references would be combined.

Specifically, Petitioner challenges the ’754 patent on obviousness grounds that all depend on a single asserted combination of prior-art references—Ganz and Larrick—sometimes in further view of additional references. Thus, the viability of every asserted ground turns on whether the Petition adequately explains what is being combined from Ganz and Larrick, how those features are combined to meet the claim limitations, and why a person of ordinary skill in the art (“POSITA”) would have been motivated to make that specific combination.

At the institution stage, Petitioner bears the burden to present its case for unpatentability expressly in the Petition, and to do so with particularity. 35 U.S.C. § 312(a)(3); 37 C.F.R. § 42.104(b)(4). Where obviousness is based on a

combination of references, that burden requires more than conclusory characterizations or high-level assertions of compatibility or benefit. *See Harmonic Inc. v. Avid Tech., Inc.*, 815 F.3d 1356, 1363-64 (Fed. Cir. 2016); *Virtek Vision Int'l ULC v. Assembly Guidance Sys., Inc.*, 97 F.4th 882, 886 (Fed. Cir. 2024). The petition must articulate a coherent, reference-specific theory explaining how the prior art is combined and why a POSITA would have been motivated to combine the prior art, supported by reasoned analysis rather than post hoc reliance on asserted results. *See TQ Delta, LLC v. CISCO Sys., Inc.*, 942 F.3d 1352, 1359 (Fed. Cir. 2019).

As set forth below, Petitioner fails to satisfy these requirements in multiple, independent respects. **First**, the Petition does not articulate its asserted obviousness grounds with the particularity required by § 312(a)(3) because it never explains—at a component or architectural level—how the teachings of Ganz and Larrick are purportedly integrated. Instead, the Petition asserts a combination at such a high level of abstraction that it is difficult to discern the actual combination of components of Ganz and Larrick. The Petition relies on ambiguous labels such as “teachings” and asserted outcomes, leaving the Board and Patent Owner to speculate about the specifics of any suggested combination. Pet., at 14, 15, 20. **Second**, even assuming that the Petition describes the suggested combination with particularity (which it did not), the Petition fails to provide a reasoned motivation to combine,

supported by rational underpinnings. As discussed below, the Petition instead relies upon generalized performance goals and circular, result-oriented reasoning. Standing alone, both Petitioner's lack of particularity for its theory of obviousness as well as its failure to supply a reasoned explanation for a motivation to combine Ganz and Larrick independently warrant denial of institution. *Third*, Petitioner's Expert Declaration does not cure those two fatal defects, as it merely parrots the Petition's conclusory assertions without supplying the missing and vital technical analysis.

Because the Petition does not meet Petitioner's statutory burden to establish a reasonable likelihood of prevailing on its obviousness challenges, the Board should deny institution.

II. STATEMENT OF THE PRECISE RELIEF REQUESTED

Patent Owner requests that the Board deny institution of the Petition with respect to all of the Challenged Claims and all asserted grounds. A full statement of the reasons for the relief requested is set forth in Sections III and IV of this Preliminary Response.

III. BACKGROUND

A. Summary of the '754 Patent

The '754 Patent describes an ultra-wideband (UWB) repeater designed for wireless networks that employs broadband communication techniques. Ex. 1001,

15:2-20. The UWB repeater and the associated network architecture allow for greater bandwidth and data rates compared to existing wireless repeater devices. Ex. 1001, 7:11-22. The UWB repeater includes one or more transceivers and a controller that together perform functions such as traffic monitoring, data screening, traffic prioritization, and selective forwarding to improve system throughput and reduce interference. Ex. 1001, 15:2-12, 17:44-56, 21:14-25. Figure 2 shows an example UWB network comprising a UWB repeater 24 in communication with a plurality of wireless devices. Ex. 1001, Fig. 2.

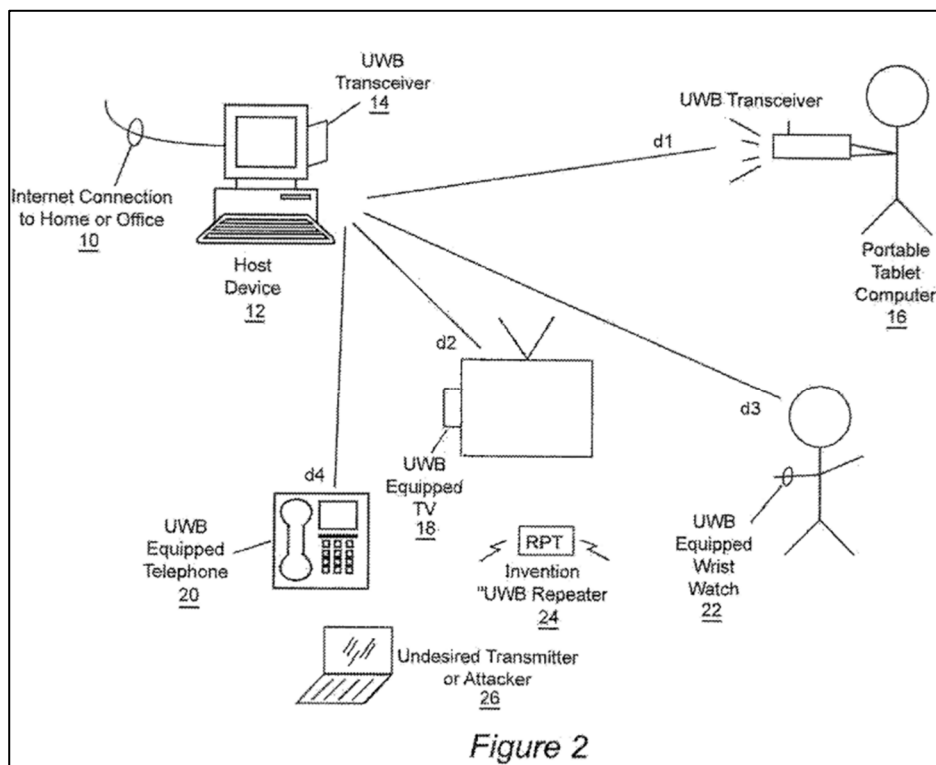

The '754 Patent further describes network operations of the repeater that control multiple frequencies and baseband signals to adapt to traffic conditions. Ex.1001,

13:10-12, 14:55-15:12. The repeater can analyze network conditions, classify or filter data, and route or repeat transmissions based on parameters such as channel quality (e.g., QoS), user priority, or service type. Ex. 1001, 15:2-12, 17:44-56, 18:14-22. This functionality depends on coordinated operations between the repeater's transceivers and controller, which manage data flow according to the operational instructions, and allows for improved network performance. Ex. 1001, 15:2-20.

B. Priority Date

The '754 Patent application was filed on November 14, 2014. Ex. 1001, field code (22). It claims priority via a series of continuations to non-provisional Application No. 10/919,515, filed August 17, 2004, now Patent 7,676,194. *Id.*, field code 63. Patent 7,676,194 in turn claims priority to two provisional applications, filed on August 22, 2003, and August 28, 2003. *Id.*, field code (60).

The pre-AIA provisions of 35 U.S.C. §§ 102, 103 apply. *See* Pub. L. No. 112-29, § 3(n)(1), 125 Stat. 284, 293 (2011).

C. Level of Ordinary Skill

For purposes of this Preliminary Response, Patent Owner accepts the skill level proposed by Petitioner for a POSITA. Petitioner's proposed POSITA is a person having "at least a Bachelor of Science in electrical engineering or a similar field and at least two years of practical experience in the field of wireless

communication applications,” where “[m]ore education can supplement for less practical experience, and vice versa.” Pet. at 13. Patent Owner reserves the right to address or refine the level of ordinary skill at a later stage of this proceeding or in any parallel litigation, should it become relevant.

D. Claim Construction

Patent Owner agrees with Petitioner that, for the purposes of this Preliminary Response, all claim terms should be given their plain and ordinary meaning as understood by a POSITA in the context of the '754 Patent and its prosecution history. Pet., 13-14.

To the extent any dispute exists regarding the meaning of a claim term, it does not provide a basis for institution. The Petition fails under the claim terms' plain and ordinary meanings, and Patent Owner reserves the right to address claim construction post-institution if necessary.

E. The Petition's Asserted Grounds

1. Grounds Asserted in the Petition

Petitioner asserts that the Challenged Claims are unpatentable under the following asserted grounds:

Ground	Basis	References	Claims
1	§103	Ganz in view of Larrick	1-6, 8-13, 15, and 20-26

Ground	Basis	References	Claims
2	§103	Ganz and Larrick in further view of Engels	14 and 19
3	§103	Ganz and Larrick in further view of Perlman	7 and 15-18

Petitioner asserts only one ground for each claim, except for claim 15, for which there are two grounds (Grounds 1 and 3).

2. Summary of the Asserted Grounds' Prior Art

a. Ganz

Ganz describes a repeater system configured for a multi-access network with a large number of users (e.g., typically greater than 20). Ex. 1005, 5:21-24. Each radio segment in the network can be encoded using its own addressing code based on a spread spectrum modulation technique. The unique modulation codes allow radios using the same code to listen to each other, while other radios operating with different codes in the same frequency band are completely transparent. Ex. 1005, 8:9-23. Ganz describes an 11-bit modulation code that corresponds to 2,048 possible codes for 2,048 possible radio segments. Ex. 1005, 8:24-32. Communications within each radio segment are spread over a 20 MHz channel, enabling the repeater to route packets among independently coded segments while maintaining security and minimizing interference. *Id.* This 11-bit modulation code enables each radio

segment to operate at a data throughput rate “preferably at least 1.5 Mb/s” or equal to the full throughput rate of a dedicated T-1 line. *Id.*

b. Larrick

Larrick discloses a UWB transmitter and receiver designed for various applications including radar, object detection, and communication applications. Ex. 1007, Abstract. Larrick describes different transmitter architectures that generate impulse-based UWB waveforms using low-level impulse generators, bandpass filters, and either an impulse-gated oscillator (Fig. 1) or a time-gated oscillator (Fig. 3). Ex. 1007, 9:36-45, 13:6-13; Figs. 1 and 3.

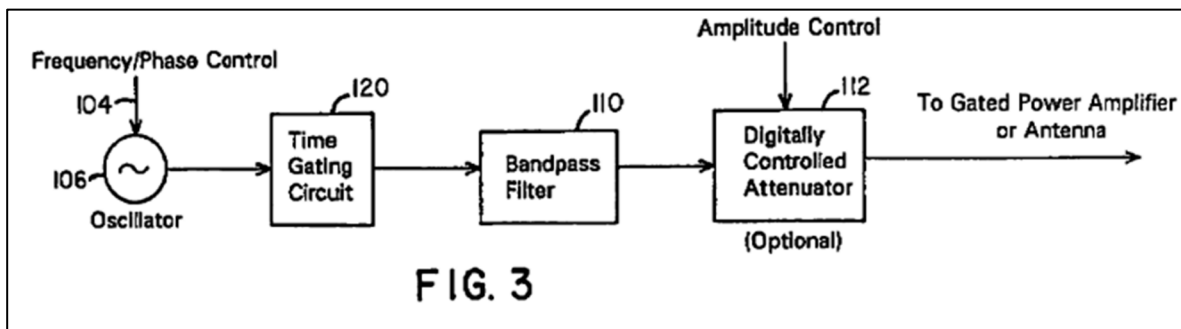
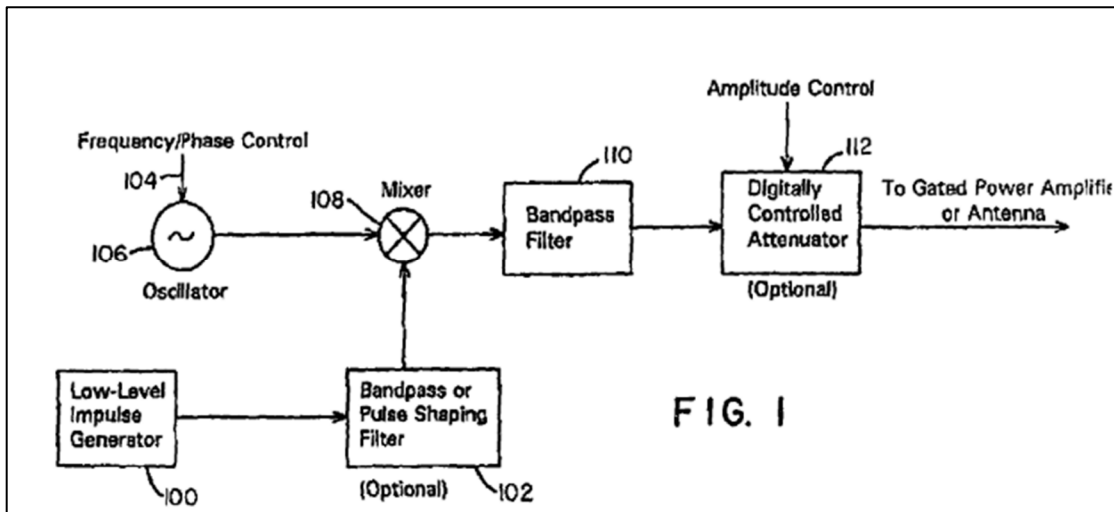

Larrick further describes a UWB receiver that improves upon conventional constant false alarm rate (CFAR) UWB receivers that require continuous updates to “the detector bias point, resulting in reduced detector sensitivity in the presence of in-band jamming (i.e., receiver back-off), and extremely slow response times because of the need to constantly recalculate the false alarm rate.” Ex. 1007, 6:52-65. Unlike conventional CFAR-based receivers, Larrick’s receiver adjusts the attenuation of the incoming UWB signals, rather than adjusting the detector bias point. *Id.*

IV. THE PETITION FAILS TO ESTABLISH A REASONABLE LIKELIHOOD OF SUCCESS ON A SINGLE CLAIM

To justify institution of an *inter partes* review, a petition must identify with particularity the evidence and reasoning supporting each asserted ground of unpatentability. 35 U.S.C. § 312(a)(3); 37 C.F.R. § 42.104(b)(4). Where a petitioner asserts obviousness based on a combination of references, the petition must articulate a reasoned motivation to combine the references, supported by rationale underpinnings. *KSR Int'l Co, v. Teleflex, Inc.*, 550 U.S. 398, 418 (2007); *Dish Network L.L.C. v. TQ Beta, LLC*, IPR2015-01791, Paper 30, 19 (PTAB Jan. 30, 2017) (petitioner failed to show that the claims were unpatentable because it failed to provide an articulated reasoning with some rational underpinning for combining the references). Conclusory assertions, general design goals, or unsupported labels such as “simple substitution” or “obvious to try” do not constitute reasoned

explanations. *See e.g., Hunting Titan, Inc. v. DynaEnergetics Europe GmbH*, PGR2020-00080, Paper 7, 11-12 (PTAB Feb. 12, 2021) (petitioner’s reliance “on generalized statements that such [obviousness] combinations would, for instance, be ‘predictable,’ ‘simple substitution,’ application of ‘known techniques,’ and ‘obvious to try’” insufficient to meet burden to justify institution); *Arendi S.A.R.L. v. Apple, Inc.*, 832 F.3d 1355, 1362 (Fed. Cir. 2016) (“references to ‘common sense’ . . . cannot be used as a wholesale substitute for reasoned analysis and evidentiary support”); *In re Nuvasive, Inc.*, 842 F.3d 1376, 1383 (Fed. Cir. 2016) (conclusory statements alone insufficiently articulate a motivation to combine).

Among other things, a petitioner must explain why and how a POSITA would have combined the references in the manner asserted, with a reasonable expectation of success. *See Procter & Gamble Co. v. Teva Pharm. USA, Inc.*, 566 F.3d 989, 994 (Fed. Cir. 2009) (party asserting obviousness must demonstrate that a skilled artisan would have been motivated to combine the teachings of the prior art references to achieve the claimed invention, and that the skilled artisan would have had a reasonable expectation of success in doing so). Expert testimony may support such a showing, but only if it provides independent technical reasoning and does more than merely repeat the Petition’s conclusions. *See InTouch Techs., Inc. v. VGO Commc’ns, Inc.*, 751 F.3d 1327, 1349-52 (Fed. Cir. 2014) (reversing finding of obviousness where expert “failed to provide the necessary ‘articulated reasoning

with some rational underpinning’ to support a conclusion of invalidity based on these combinations”).

As set forth below, the Petition fails to meet these requirements in multiple, independent respects.

A. Petitioner Fails to Articulate Its Obviousness Grounds with Particularity

To institute *inter partes* review, a petition must identify “with particularity” the evidence and reasoning supporting each asserted ground of unpatentability. 35 U.S.C. § 312(a)(3); 37 C.F.R. § 42.104(b)(4). Where, as here, a petitioner asserts obviousness based on a combination of references, the petition must articulate—not merely imply—what aspects of the references are combined, how they are combined, and why a POSITA would have been motivated to make that specific combination. *Harmonic*, 815 F.3d at 1363–64.

The Petition does not satisfy the particularity requirement imposed by statute and Federal Circuit precedent. As explained below, the Petition never articulates a coherent, component-level or protocol-layer theory for combining Ganz and Larrick with particularity, nor does it articulate a legally sufficient motivation to combine. Each of those two deficiencies independently require denial of institution and are apparent from the face of the Petition itself.

1. The Petition Does Not Assert a Coherent Theory for Combining Ganz and Larrick

The Ganz-Larrick combination, either alone or in further view of additional references, forms part of every ground asserted in the Petition. Pet., 4. Accordingly, Petitioner’s articulation of why and how Ganz and Larrick are combined is foundational to all asserted obviousness challenges.

Petitioner’s stated logic for combining the references is that Ganz discloses a wireless repeater system, and Larrick discloses UWB transmission techniques that are allegedly “complementary” to Ganz. Pet., 14. According to Petitioner, a POSITA would have recognized that “Larrick’s teachings could be easily implemented into Ganz without technical challenge.” *Id.*, 15; Ex. 1002 ¶71.

In describing the asserted combination, Petitioner refers generally to “Larrick’s UWB technology,” “adaptable UWB parameters,” and “well-defined and controllable spectral characteristics” disclosed in Larrick. Pet., 14–20; Ex. 1002, ¶¶72-87. Petitioner asserts that incorporating these features into Ganz would increase transmission bandwidth from approximately 20 MHz to approximately 400 MHz and increase data rates from approximately 1.5 Mb/s to hundreds of megabits per second. Pet., 19; Ex. 1002, ¶¶84-86.

Petitioner, however, does not describe the asserted combination at a component or architectural level. The Petition does not identify which transmitter,

receiver, controller, or signal-processing elements disclosed in Larrick are incorporated into Ganz's repeater system, nor does the Petition describe how any such elements would interface with or modify Ganz's existing architecture. For example, Ganz points out that two physical layers have been developed in the context of IEEE 802.11 (Wi-Fi) networks at the time, frequency-hopping spread-spectrum (FHSS) and direct-sequence spread spectrum (DSSS). Ex. 1005, 7:1-7:51. Neither the Petition nor Petitioner's expert, however, articulates how Larrick's UWB transmitter would integrate or replace Ganz' physical (PHY) layer. Petitioner and its expert also fail to address how a POSITA would integrate Larrick's UWB transmitter with Ganz' medium-access control (MAC) layer. Petitioner, therefore, fails to specify which elements would be modified or substituted to achieve the performance results described by Larrick. Instead, the Petition characterizes the asserted combination in terms of the performance outcomes that the combination would purportedly achieve, without describing the underlying structural or operational changes required to realize the asserted bandwidth and data throughput performance. Pet., 14-20; Ex. 1002, ¶¶72-87.

Indeed, rather than describing the underlying combination of specific elements, Petitioner simply changes the subject, turning to a discussion of receiver calibration and object-detection applications without articulating any connection between these concepts and the claimed bandwidth or data-rate requirements of the

Challenged Claims. Pet., 30. Petitioner likewise fails to explain specifically how any signal-processing structures of Larrick would be incorporated into Ganz to account for the asserted and substantial increase in transmission bandwidth—from 20 MHz in Ganz to 400 MHz in Larrick. Pet., 28-29. In the absence of a reasoned, component-level explanation, the Petition relies on conclusory assertions and never describes any specific feature of Larrick that would be used to modify Ganz in the manner required by the Challenged Claims. Instead, Petitioner resorts to the vague and legally insufficient assertion that Ganz and Larrick are “complementary.” Pet., 15–16. As a result, Petitioner’s obviousness combinations amount to legal conclusions unsupported by reasoned technical analysis and do not justify institution.

2. The Petition Does Not Articulate a Coherent Obviousness Theory for Ground 1

A petitioner bears the burden of clearly explaining *how* the asserted prior-art references are combined to render the challenged claims unpatentable. *Harmonic*, 815 F.3d at 1363. Neither the Board nor the Patent Owner is required to infer, reconstruct, or “decode” an unarticulated theory of obviousness. *Netflix, Inc. v. DivX, LLC*, 84 F.4th 1371, 1377 (Fed. Cir. 2023).

Here, Petitioner never identifies specific elements of Larrick that could be incorporated into specified portions of Ganz’s repeater architecture. Instead,

Petitioner improperly relies on vague and generic phrases, such as “Larrick’s UWB technology,” “adaptable UWB parameters,” and “well-defined and controllable spectral characteristics,” without tying those phrases to any disclosed structure, circuitry, or signal-processing operation. Pet. 14–20. For example, Petitioner asserts that:

The teachings of Ganz are complementary to Larrick, and a POSITA would have recognized that Larrick’s teachings could be easily implemented into Ganz without technical challenge.

Pet. 14–15 (citing Ex. 1002 ¶71). But Petitioner never identifies what those “teachings” are, what components could implement such “teachings,” or how they would be integrated into Ganz. Nor does Petitioner explain whether Petitioner contends that Larrick’s transmitter, receiver, or both would be incorporated into Ganz, or how such components would interface with Ganz’s existing transceivers and controller.

The Federal Circuit has repeatedly rejected this type of results-oriented and component-free analysis. In *ActiveVideo Networks, Inc. v. Verizon Commc’ns, Inc.*, the court held that expert testimony is insufficient where it failed to explain “how specific references could be combined, which combination(s) of elements would yield a predictable result, or how any specific combination would operate or read on the asserted claims.” 694 F.3d 1312, 1327 (Fed. Cir. 2012). The Petition here suffers

from precisely the same defects that the Federal Circuit identified in *ActiveVideo Networks*.

The Petition’s lack of particularity is evident from its own language. The examples below illustrate statements in the Petition that are asserted without any accompanying explanation of what elements are combined, how they are combined, or how the asserted results are achieved. The following non-exhaustive examples illustrate that the Petition relies on conclusory characterizations and asserted outcomes without explaining what is combined, how it is combined, and why.

Petition Statement	What the Petition Does Not Explain
“The <i>teachings of Ganz are complementary to Larrick</i> , and a POSITA would have recognized that <i>Larrick’s teachings could be easily implemented</i> into Ganz <i>without technical challenge</i> .” Pet., 14-15 (emphasis added).	<ul style="list-style-type: none">• Fails to explain how teachings are complementary or what is meant by complementary;• Fails to explain why the teaching could be easily implemented, or what specific elements are being implemented/combined;• Fails to explain why the unidentified combination of elements could be implemented/combined without technical challenges.

Petition Statement	What the Petition Does Not Explain
<p>“These technologies address different aspects of wireless communication that <i>could naturally work together</i> including Larrick’s use of wider frequency bandwidths than those disclosed in Ganz.” Pet., 15 (emphasis added).</p>	<ul style="list-style-type: none"> • Fails to explain how Ganz and Larrick could work together to produce the claimed data rate or bandwidth.
<p>“These significant improvements in data rate capabilities – from Ganz’ 1.5 Mb/s to Larrick’s ‘hundreds of megabits per second’ – <i>represent precisely the kind of technological advancement that would motivate a POSITA to combine these references.</i>” Pet., 19 (emphasis added).</p>	<ul style="list-style-type: none"> • Fails to identify the specific technological advancements • Fails to explain how or why a POSITA would look to incorporate these unknown technological advancements into Ganz
<p>“Larrick’s ‘gated power amplifier’ with ‘the unique feature of high power efficiency as the power amplifier is only turned on for approximately the duration of the UWB pulse’ (EX1007, 6:42-45) <i>would be particularly valuable</i> in Ganz’ repeater network.” Pet., 18 (emphasis added).</p>	<ul style="list-style-type: none"> • Fails to explain why a POSITA would consider technologies that address power efficiency, in view of the claimed invention

Petition Statement	What the Petition Does Not Explain
<p>“‘wireless high speed data communication system’ of Ganz (EX1005, Abstract), <i>would benefit</i> from Larrick’s UWB technology.” Pet., 15 (emphasis added).</p>	<ul style="list-style-type: none"> • Fails to identify the specific “UWB technology,” how it is combined with Ganz, or how Ganz would benefit
<p>“Larrick introduces sophisticated UWB signal generation methods that <i>would significantly enhance</i> the Ganz system.” Pet., 16 (emphasis added).</p>	<ul style="list-style-type: none"> • Fails to identify the specific “sophisticated UWB signal generation method,” how it is combined with Ganz, or how Ganz would be “significantly enhanced”
<p>“The combination <i>would particularly benefit</i> from the complementary modulation approaches described in both patents.” Pet., 16 (emphasis added).</p>	<ul style="list-style-type: none"> • Fails to identify what the “complementary modulation approaches” are, or why they would “particularly benefit”

The examples in the table above demonstrate that, throughout the Petition, Petitioner relies on generalized characterizations and asserted performance outcomes without articulating what elements are combined, how they are combined, or why a POSITA would have been motivated to make the specific Ganz–Larrick combination, as asserted. As a result, the Petition fails to articulate its obviousness grounds with the particularity required by 35 U.S.C. § 312(a)(3) and institution

should be denied.

3. The Petition Fails to Articulate Any Motivation to Combine With Particularity

The lack of a particular description of the proposed Ganz and Larrick combination likewise defeats Petitioner’s asserted motivation to combine. A motivation to combine must be directed to a specific combination of specific references, not to a desired outcome or performance goal. *See Innogenetics, N.V. v. Abbott Lab ’ys.*, 512 F.3d 1363, 1373 (Fed. Cir. 2008) (“knowledge of a problem and motivation to solve it are entirely different from motivation to combine particular references to reach the particular claimed method”); *ActiveVideo*, 694 F.3d at 1327.

Here, Petitioner identifies a general desire to increase bandwidth and data rate, but never explains why a POSITA would have selected Larrick in particular, or why a POSITA would have modified Ganz in the specific manner required by the Challenged Claims. Pet. 14–20; Ex. 1002, ¶¶71-87. Instead, Petitioner relies on the magnitude of Larrick’s reported performance metrics as the alleged motivation, coupled with conclusory assertions that the teachings are “complementary” and “easily implemented.” Pet., 15; Ex. 1002, ¶71.

Petitioner’s stated rationale, to combine Larrick’s results, is improperly circular and insufficient under governing authorities. *See Innogenetics*, 512 F.3d at 1373; *ActiveVideo*, 694 F.3d at 1327. A generalized desire for improved performance

does not explain why a POSITA would combine Larrick and Ganz in any specific way. Nor is Petitioner allowed to rely on the generalized improved results of the combination as proof of both the motivation for and obviousness of the proposed combination. *ActiveVideo*, 694 F.3d at 1328 (an asserted motivation to make a system “better” or “more efficient” is insufficient because it is “generic and bears no relation to any specific combination of prior art elements”).

Because Petitioner never articulates what is actually being combined from Ganz and Larrick, or how such a combination would be implemented, the Petition necessarily fails to articulate a legally sufficient motivation to combine and cannot justify institution.

4. Grounds 2 and 3 Fail for the Same Lack of Particularity as Ground 1

Grounds 2 and 3 rely on the same underlying combination of Ganz and Larrick and merely add Engels or Perlman for additional limitations. Because Petitioner fails to articulate with particularity how Ganz and Larrick are combined in the first instance, Grounds 2 and 3 necessarily fail as well and cannot support institution. *See Harmonic*, 815 F.3d at 1363–64.

B. Petitioner’s Motivation to Combine Ganz and Larrick Lacks Rational Underpinning

Even assuming, for the sake of argument, that Petitioner does describe a specific combination of Ganz and Larrick (which Petitioner does not), institution

should still be denied because Petitioner independently fails to establish a reasoned motivation to combine supported by rational underpinning, as required by *KSR*. 550 U.S. at 418. A petitioner must do more than identify a generalized goal or desired outcome; it must explain why a POSITA would have selected the particular references and combined them in the specific manner required by the claims. *In re Kahn*, 441 F.3d 977, 987–88 (Fed. Cir. 2006); *In re Rouffet*, 149 F.3d 1350, 1355–59 (Fed. Cir. 1998).

Petitioner purports to identify multiple “categories” of motivations to combine Ganz and Larrick—such as modulation techniques, spectral efficiency, power considerations, and industry trends—but Petitioner’s analysis ultimately reduces to a single, generalized rationale: that a POSITA would have sought to increase transmission bandwidth and data throughput. Pet., 14–20. That vague and generalized rationale is legally insufficient. “[K]nowledge of a problem and motivation to solve it are entirely different from motivation to combine particular references to reach the claimed invention.” *Innogenetics*, 512 F.3d at 1373. A generalized desire for improved performance does not explain why a POSITA would have selected Larrick in particular, nor why the POSITA would have modified Ganz in the manner required by the claims.

Rather than articulating a reference-specific rationale grounded in the teachings of the prior art, Petitioner relies on the magnitude of the performance

metrics reported in Larrick itself—such as “hundreds of megabits per second” data rates and “400 MHz” bandwidth—as the asserted motivation for the combination. Pet., 15, 19. That reasoning is circular. It uses the purported results of Larrick as both the motivation for the combination and the justification for the assertion that it would be obvious to combine Larrick with Ganz, without identifying any technological principle that would have led a POSITA to combine Ganz and Larrick in the first place. Such result-oriented reasoning is insufficient under *KSR* and reflects impermissible hindsight. *Innogenetics*, 512 F.3d at 1373; *TQ Delta*, 942 F.3d at 1361.

Petitioner’s reliance on asserted ancillary “benefits,” such as alleged advantages of power amplifiers or secondary features, does not supply the missing rational underpinning. Unsupported assertions of secondary advantages, untethered to a reference-specific motivation to arrive at the claimed invention, do not establish why a POSITA would have made the proposed combination. *TQ Delta*, 942 F.3d at 1359, 1362.

In short, even accepting Petitioner’s asserted combination at face value, the Petition fails to articulate a reasoned motivation to combine Ganz and Larrick. Because Petitioner relies on generalized performance goals and post hoc reliance on purported results, rather than a reference-specific rationale grounded in the prior art, the Petition does not establish a reasonable likelihood of prevailing on any of the

asserted grounds of obviousness and so *inter partes* review should not be instituted.

C. Petitioner’s Expert Declaration Does Not Cure the Deficiencies in the Petition

A petitioner bears the burden to demonstrate unpatentability in the petition itself, with particularity. 37 C.F.R. § 42.104(b)(4). That burden cannot be shifted to the Patent Owner or the Board, nor satisfied through conclusory assertions or arguments developed outside the Petition. *Harmonic*, 815 F.3d at 1363–64. Accordingly, where—as explained above—the Petition fails to articulate its obviousness grounds with particularity and fails to provide a reasoned motivation to combine supported by rational underpinning, those defects cannot be cured by an expert declaration. *See Consolidated Trial Practice Guide November 2019*, pp. 35-36 (“parties that incorporate expert testimony by reference in their petitions, motions, or replies without providing explanation of such testimony risk having the testimony not considered by the Board”); *Cisco Systems, Inc. v. C-Cation Techs., LLC*, IPR2014-00454, Paper 12 at 9 (PTAB Aug. 29, 2014) (informative) (the “practice of citing the Declaration to support conclusory statements that are not otherwise supported in the Petition also amounts to incorporation by reference” and such declarations are not considered).

Further, expert testimony must provide independent technical analysis and may not simply restate attorney argument. 37 C.F.R. § 42.65(a); *Upjohn Co. v. Mova*

Pharm. Corp., 225 F.3d 1306, 1311 (Fed. Cir. 2000). In *Xerox Corp. v. Bytemark, Inc.*, the Board accorded an expert declaration little to no weight where it merely reproduced the petition’s assertions verbatim, without supplying the missing analysis. IPR2022-00624, Paper 9 at 20–21 (PTAB Aug. 24, 2022) (precedential). The situation is very much the same here.

The declaration of Dr. Mahon closely tracks the Petition’s assertions and adds no independent technical reasoning addressing the deficiencies identified above. *Compare* Pet., 4–59 with Ex. 1002, ¶¶ 40–174. Aside from a brief, generalized discussion of internet backbone infrastructure (Ex. 1002, ¶ 115), the declaration does not provide any analysis explaining the asserted combination or supplying a reasoned motivation to combine grounded in the teachings of the prior art.

The following non-exhaustive examples illustrate that Dr. Mahon’s declaration merely reproduces the Petition’s assertions verbatim, without providing the independent technical analysis required to cure the Petition’s defects:

Petition	Expert Declaration
“The teachings of Ganz are complementary to Larrick, and a POSITA would have recognized that Larrick’s teachings could be easily implemented into Ganz without	“The teachings of Ganz are complementary to Larrick, and a POSITA would have recognized that Larrick’s teachings could be easily implemented into Ganz without

Petition	Expert Declaration
<p>technical challenge and with a reasonable expectation of success. (EX1002, ¶71.)” Pet., 14-15.</p>	<p>technical challenge and with a reasonable expectation of success.” Ex. 1002, ¶71.</p>
<p>“These significant improvements in data rate capabilities – from Ganz’ 1.5 Mb/s to Larrick’s “hundreds of megabits per second” – represent precisely the kind of technological advancement that would motivate a POSITA to combine these references. The substantially increased bandwidth of Larrick’s UWB system (400 MHz and greater compared to Ganz’ 20 MHz) would directly enable these higher data rates. (EX1002, ¶86.)” Pet., 19.</p>	<p>“These significant improvements in data rate capabilities – from Ganz’ 1.5 Mb/s to Larrick’s “hundreds of megabits per second” – represent precisely the kind of technological advancement that would motivate a POSITA to combine these references. The substantially increased bandwidth of Larrick’s UWB system (400 MHz and greater compared to Ganz’ 20 MHz) would directly enable these higher data rates.” Ex. 1002, ¶86.</p>
<p>“In the object detection applications described in Larrick, it would be advantageous if not required that the transmitter have the same frequency bandwidth as the receiver. (EX1002, ¶114.)” Pet., 30.</p>	<p>“In the object detection applications described in Larrick, it would be advantageous if not required that the transmitter have the same frequency bandwidth as the receiver.” Ex. 1002, ¶114.</p>

As in *Xerox*, such verbatim repetition of attorney argument does not constitute

independent expert analysis and cannot cure deficiencies in the Petition. See *Xerox*, Paper 9 at 20–21; 37 C.F.R. § 42.65(a).

Nor could Petitioner cure these deficiencies through reply briefing or supplemental expert testimony. A petitioner may not use later-filed arguments or evidence to remedy defects in the original petition. *Redline Detection, LLC v. Star Envirotech, Inc.*, 811 F.3d 435, 440–44 (Fed. Cir. 2015); *In re Magnum Oil Tools Int'l, Ltd.*, 829 F.3d 1364, 1375–77 (Fed. Cir. 2016). Institution must be based on the Petition as filed, not on arguments or analysis developed after the fact.

Because the Petition fails to articulate its obviousness grounds with particularity and fails to provide a reasoned motivation to combine supported by rational underpinning—and because the expert declaration does not cure those defects—Petitioner has not met its burden to establish a reasonable likelihood of success. Institution should therefore be denied.

V. CONCLUSION

For the reasons set forth above, the *inter partes* review should not be instituted.

Dated: January 6, 2026

Respectfully submitted,

By: /Patrick J. McElhinny/
Patrick J. McElhinny
Reg. No. 46,320
K&L Gates Center, 210 Sixth Avenue
Pittsburgh, Pennsylvania 15222
Tel.: (412) 355-6334
patrick.mcelhinny@klgates.com

Counsel for Patent Owner

**CERTIFICATE OF COMPLIANCE WITH TYPE-VOLUME
LIMITATION, TYPEFACE REQUIREMENTS, AND TYPE STYLE
REQUIREMENTS**

1. This Patent Owner Preliminary Response complies with the type-volume limitation of 14,000 words, comprising 5,092 words, as counted using the Microsoft Word software that was used to prepare this paper, excluding the parts exempted by 37 C.F.R. § 42.24(a), (b).

2. This Patent Owner Preliminary Response complies with the general format requirements of 37 C.F.R. § 42.6(a) and has been prepared using Microsoft Word 2016 in 14-point Times New Roman.

Date: January 6, 2026

By: /Mark G. Knedeisen/
Mark G. Knedeisen (Reg. No. 42,747)
K&L Gates Center, 210 Sixth Avenue
Pittsburgh, Pennsylvania 15222
Tel.: (412) 355-6342
mark.knedeisen@klgates.com

CERTIFICATION OF SERVICE

I hereby certify that on January 6, 2026, I caused a true and correct copy of the foregoing to be served on the following counsel for Petitioners by electronic mail to the following email address:

James M. Glass
jimglass@quinnemanuel.com
QUINN EMANUEL URQUHART
& SULLIVAN, LLP
295 5th Avenue, 9th Floor
New York, New York 10016

John McKee
johnmckee@quinnemanuel.com
Matthew Robson
matthewrobson@quinnemanuel.com
Ron Hagiz
ronhagiz@quinnemanuel.com
QUINN EMANUEL URQUHART
& SULLIVAN, LLP
295 5th Avenue, 9th Floor
New York, New York 10016

Quincy Lu
quincylu@quinnemanuel.com
QUINN EMANUEL URQUHART
& SULLIVAN, LLP
1109 First Avenue, Suite 210
Seattle, WA 98101

Benjamin Kleinman
benjaminkleinman@quinnemanuel.com
QUINN EMANUEL URQUHART
& SULLIVAN, LLP
50 California Street, 22nd Floor
San Francisco, CA 94111

Sandy Shen
sandyshen@quinnemanuel.com
QUINN EMANUEL URQUHART
& SULLIVAN, LLP
1300 I Street NW, Suite 900
Washington, D.C. 20005

qe-samsung-mbl-ipr@quinnemanuel.com

By: /Mark G. Knedeisen/
Mark G. Knedeisen (Reg. No. 42,747)
K&L Gates Center, 210 Sixth Avenue

Pittsburgh, Pennsylvania 15222
Tel.: (412) 355-6342
mark.knedeisen@klgates.com