

UNITED STATES PATENT AND TRADEMARK OFFICE

---

BEFORE THE PATENT TRIAL AND APPEAL BOARD

---

APPLE INC.,  
Petitioner,

v.

OMNI MEDSCI, INC.,  
Patent Owner.

Patent No. 9,885,698

---

*Inter Partes* Review No. IPR2019-00915

---

**Petition for *Inter Partes* Review of  
U.S. Patent No. 9,885,698**

**Table of Contents**

**I. Introduction .....1**

**II. Certifications; Grounds.....2**

**A. Petitioner May Contest the '698 Patent (§ 42.104(a)) .....2**

**B. Identification of Claims Being Challenged (§ 42.104(b)) .....3**

**C. Fee for *Inter Partes* Review (§ 42.15(a)).....3**

**D. Service on Patent Owner (§ 42.105) .....3**

**III. Background Technology .....4**

**A. Photoplethysmography .....4**

**B. Prevailing Industry Trends Before 2012 .....6**

**IV. The '698 Patent .....11**

**A. Illustrative Claim .....11**

**B. The '698 Patent and Its Prosecution .....11**

**C. The '698 Patent Is Subject to AIA .....12**

**D. Person of Ordinary Skill in the Art .....16**

**V. Claim Construction.....16**

**VI. Detailed Explanation Why the '698 Patent Claims Are Unpatentable ..20**

**A. Lisogurski and Carlson Render Obvious Claims 1-3 and 5 .....20**

        1. Overview of Lisogurski .....20

        2. Overview of Carlson .....22

        3. A Skilled Person Would Have Modified Lisogurski to Incorporate Elements Shown in Carlson .....23

        4. Theoretical Distinctions Between Lisogurski and Claims 1-3, and 5 .....26

        5. Independent Claim 1 .....27

            a) Preamble .....27

            b) “a measurement device...” .....28

- c) “the measurement device comprising one or more lenses configured to receive and to deliver a portion of the input optical beam to tissue, wherein the tissue reflects at least a portion of the input optical beam delivered to the tissue” .....31
- d) “the measurement device further comprising a receiver, wherein the receiver includes a plurality of spatially separated detectors” .....36
- e) wherein at least one analog to digital converter is coupled to the spatially separated detectors and is configured to generate at least a first data signal from the first signal and at least a second data signal from the second signal44
- f) the measurement device configured to improve a signal-to-noise ratio of the input optical beam reflected from the tissue by differencing the first data signal and the second data signal to generate an output signal representing at least in part a non-invasive measurement on blood contained within the tissue .....45
- g) wherein the modulating at least one of the LEDs has a modulation frequency, and wherein the receiver is configured to use a lock-in technique that detects the modulation frequency .....47
- 6. Claim 2 .....51
- 7. Claim 3 .....53
  - a) “the light source is configured to further improve the signal-to-noise ratio...” .....53
  - b) “...by increasing the light intensity relative to the initial light intensity from at least one of the LEDs” .....57
  - c) “wherein the receiver is configured to be synchronized to at least one of the LEDs” .....58
- 8. Claim 5 .....59
- B. Lisogurski, Carlson, and Hanna Render Obvious Claims 1-3, 5 .62**
  - 1. Overview of Hanna .....62
  - 2. A Skilled Person Would Have Combined Lisogurski and Carlson With Hanna.....64

- 3. Lisogurski, Carlson, and Hanna Render Obvious Claims 1-3 and 5 .....66
- C. Lisogurski, Carlson, and Rulkov, with or without Hanna, Render Obvious Claim 5.....67**
  - 1. Overview of Rulkov.....67
  - 2. A Skilled Person Would Have Modified Lisogurski and Carlson to Incorporate Elements Shown in Rulkov .....67
  - 3. Claim 5 .....69
- D. No Secondary Considerations Exist.....71**
- VII. Conclusion .....72**
- Claim Appendix .....1**

**TABLE OF AUTHORITIES**

<b>Cases</b>	<b>Page(s)</b>
<i>Droplets, Inc. v. E*TRADE Bank</i> , 887 F.3d 1309 (Fed. Cir. 2018).....	14
<i>Hologic, Inc. v. Smith &amp; Nephew, Inc.</i> , 884 F.3d 1357 (Fed. Cir. 2018).....	12
<i>Kennametal, Inc. v. Ingersoll Cutting Tool Co.</i> , 780 F. 3d 1376 (Fed. Cir. 2015).....	60
<i>Lockwood v. American Airlines</i> , 107 F.3d 1565 (1997).....	13
<i>In re Petering</i> , 301 F.2d 676 (CCPA 1962) .....	60
<i>Sinorgchem Co., Shandong v. Int’l Trade Comm’n</i> , 511 F.3d 1132 (Fed. Cir. 2007).....	18
 <b>Statutes</b>	
35 U.S.C. § 102 .....	20, 22, 62, 67
35 U.S.C. § 103 .....	3
35 U.S.C. § 111 .....	15
35 U.S.C. § 112 .....	12, 13, 14
35 U.S.C. § 119 .....	12
35 U.S.C. §122 .....	15
35 U.S.C. § 315(b).....	3
Pub. L. 112-29, §3(n).....	12
 <b>Other Authorities</b>	
37 C.F.R. 1.215.....	15
37 C.F.R. § 1.57(d).....	14

37 CFR § 42.15(a) .....3  
M.P.E.P. 903.04.....15  
M.P.E.P. 1121 .....15  
M.P.E.P. 2159.02.....12

**Exhibit List**

<b>Exhibit #</b>	<b>Reference Name</b>
1001	U.S. Patent No. 9,885,698 (“the ’698 Patent”)
1002	U.S. Patent No. 9,885,698 File History
1003	Declaration of Brian W. Anthony, PhD
1004	Proof of Service of Summons in Omni MedSci, Inc. v. Apple Inc., No. 2:18-cv-134 (E.D. Tex.)
1005	U.S. Patent Publication No. 2012/0197093 (“Valencell-093”)
1006	U.S. Patent Publication No. 2010/0217099 (“Valencell-099”)
1007	U.S. Patent No. 6,505,133 (“Hanna”)
1008	U.S. Patent No. 5,746,206 (“Mannheimer”)
1009	U.S. Patent Publication No. 2005/0049468 (“Carlson”)
1010	U.S. Patent No. 9,596,990 (“Park”)
1011	U.S. Patent No. 9,241,676 (“Lisogurski”)
1012	RESERVED
1013	RESERVED
1014	U.S. Patent No. 8,172,761 (“Rulkov”)
1015	U.S. Provisional Application No. 61/747,487
1016	U.S. Provisional Application No. 61/747,472
1017	Provisional Application No. 61/747,477
1018	Provisional Application No. 61/754,698
1019	“The Biomedical Engineering Handbook,” by Joseph D. Bronzino (1995) (“BE Handbook”)
1020	M. Krantz, et al., The mobile fitness coach: Towards individualized skill assessment using personalized mobile devices, Pervasive and Mobile Computing (June 2012)

<b>Exhibit #</b>	<b>Reference Name</b>
1021	Patel, et al., A review of wearable sensors and systems with application rehabilitation, Journal of Neuroengineering & Rehabilitation 2012 9:21
1022	ScienceDirect Report on M. Krantz, et al., The mobile fitness coach: Towards individualized skill assessment using personalized mobile devices, Pervasive and Mobile Computing (2012), available at <a href="https://www.sciencedirect.com/science/article/pii/S1574119212000673?via%3Dihub">https://www.sciencedirect.com/science/article/pii/S1574119212000673?via%3Dihub</a>
1023	"The Usage of Tablets in the HealthCare Industry," by Rauf Adil, available at <a href="https://www.healthcareitnews.com/blog/usage-tablets-healthcare-industry">https://www.healthcareitnews.com/blog/usage-tablets-healthcare-industry</a> (Aug. 2, 2012)
1024	A. More, Bluetooth Low Energy: Wireless Connectivity for Medical Monitoring, Journal of Diabetes Science & Technology (Mar. 2010)
1026	Buttussi, Fabio, Chittaro, Luca, MOPET: A context-aware and user-adaptive wearable system for fitness training (2008)
1027	P. Baum, et al., Strategic Intelligence Monitor on Personal Health Systems, Phase 2: Market Developments - Remote Patient Monitoring and Treatment, Telecare, Fitness/Wellnes and mHealth, JRC Scientific and Policy Reports of European Commission (2013)
1027	P. Baum, et al., Strategic Intelligence Monitor on Personal Health Systems, Phase 2: Market Developments - Remote Patient Monitoring and Treatment, Telecare, Fitness/Wellnes and mHealth, JRC Scientific and Policy Reports of European Commission (2013)
1028	Compendium of Chemical Terminology Gold Book Version 2.3.3, February 24, 2014
1029	M. Swan, Senior Mania! The Internet of Things, Wearable Computing, Objective Metrics, and the Quantified Self 2.0, Journal of Sensor and Actuator Networks (2012)
1030	Merriam-Webster's Collegiate Dictionary, Eleventh Edition
1031	U.S. Patent Publication No. 2012/0041767 ("Hoffman")
1032	U.S. Patent No. 7,278,966 ("Hjelt")
1033	Lister et al., Optical properties of human skin (Journal of Biomedical Optics 2012)

<b>Exhibit #</b>	<b>Reference Name</b>
1034	Bashkatov et al., Optical properties of human skin, subcutaneous and mucous tissues in the wavelength range from 400 to 2000 nm, <i>Journal of Physics D: Applied Physics</i> (2005)
1035	E.F. Schubert, <i>Light-Emitting Diodes</i> (Cambridge Univ. Press, 2nd ed. reprinted 2014)
1035	E.F. Schubert, <i>Light-Emitting Diodes</i> (Cambridge Univ. Press, 2nd ed. reprinted 2014)
1036	Barolet, Daniel, <i>Light-Emitting Diodes (LEDs) in Dermatology</i> (Seminars in Cutaneous Medicine and Surgery 2008)
1037	RESERVED
1038	RESERVED
1039	Omni MedSci Inc.'s Opening Claim Construction Brief, No. 2:18-cv-134-RWS (filed December 20, 2018)
1040	Apple Inc.'s Preliminary Claim Constructions and Extrinsic Evidence Pursuant to Patent Local Rule 4-2, No. 2:18-cv-134-RWS (filed November 1, 2018)
1041	Exhibit E from , Excerpts from the American Heritage Dictionary, 5th Edition, filed January 14, 2019, No. 2:18-cv-134-RWS
1042	Exhibit O, Excerpts from the American Heritage Dictionary, 5th Edition. Filed January 14, 2019. No. 2:18-cv-134-RWS
1043	Amended Joint Claim Construction and Prehearing Statement. Filed January 11, 2019. No. 2:18-cv-134-RWS
1044	Claim Construction Markman Hearing Transcript, February 6, 2019. No. 2:18-cv-134-RWS
1045	Omni Preliminary Proposed Claim Constructions Pursuant to P.R. 4-2. Served on November 1, 2018. Case No. 2:18-cv-134-RWS
1046	Exhibit G, Excerpts from Merriam-Webster's Collegiate Dictionary, Eleventh Edition, No. 2:18-cv-134-RWS
1047	Exhibit N, Excerpts from Merriam-Webster's Collegiate Dictionary, Eleventh Edition, No. 2:18-cv-134-RWS
1048	U.S. Patent No. 6,044,283 ("Fein")
1049	U.S. Patent No. 5,774,213 ("Trebino")
1050	U.S. Patent No. 5,855,550 ("Lai")
1051	U.S. Patent No. 6,898,451 ("Wuori")

<b>Exhibit #</b>	<b>Reference Name</b>
1052	U.S. Patent No. 4,972,331 (“Chance”)
1053	Curriculum Vitae of Brian W. Anthony, PhD
1054	Dr. Mohammed Islam, Faculty Profile, University of Michigan, College of Engineering (available at <a href="https://islam.engin.umich.edu">https://islam.engin.umich.edu</a> )
1055	Technology Transfer Policy, University of Michigan (available at <a href="https://techtransfer.umich.edu/for-inventors/policies/technology-transfer-policy/">https://techtransfer.umich.edu/for-inventors/policies/technology-transfer-policy/</a> )
1056	Bylaws of the University of Michigan Board of Regents, (available at <a href="http://www.regents.umich.edu/bylaws/bylawsrevised_09-18.pdf">http://www.regents.umich.edu/bylaws/bylawsrevised_09-18.pdf</a> )

**Petitioner's Mandatory Notices**

**A. Real Party in Interest (§42.8(b)(1))**

The real party in interest of this petition pursuant to § 42.8(b)(1) is Apple Inc. (“Apple”) located at One Infinite Loop, Cupertino, CA 95014.

**B. Other Proceedings (§42.8(b)(2))**

**1. Patents and Applications**

U.S. Patent No. 9,885,698 (“’698 patent”) is related to following issued patents or pending applications:

- U.S. Patent No. 9,494,567
- U.S. Appl. No. 15/888,052
- U.S. Appl. No. 16/029,611

**2. Related Litigation**

The ’698 patent has been asserted in the following litigations:

- *Omni MedSci, Inc. v. Apple Inc.*, Action No. 2-18-cv-00134-RWS  
(pending);
- *Omni MedSci, Inc. v. Apple Inc.*, Action No. 2-18-cv-00429-RWS  
(pending).

**3. Patent Office Proceedings**

The ’698 patent is subject IPR2019-00912 filed by Apple.

**C. Lead and Backup Lead Counsel (§42.8(b)(3))**

Lead Counsel is: Jeffrey P. Kushan (Reg. No. 43,401), jkushan@sidley.com, (202) 736-8914. Back-Up Lead Counsel are: Ching-Lee Fukuda (Reg. No. 44,334), clfukuda@sidley.com, (212) 839-7364; Kathi Cover (Reg. No. 37,803), kcover@sidley.com, (202) 736-8377; and Thomas A. Broughan III (Reg. No. 66,001), tbroughan@sidley.com, (202) 736-8314.

**D. Service Information (§42.8(b)(4))**

Service on Petitioner may be made by e-mail (iprnotices@sidley.com), mail or hand delivery to: Sidley Austin LLP, 1501 K Street, N.W., Washington, D.C. 20005. The fax number for lead and backup lead counsel is (202) 736-8711.

**I. Introduction**

Health monitoring systems based on optical sensors, which measure physiological parameters of a user based on how light interacts with the user's tissue and blood, have been ubiquitous for decades. Once found only in hospitals and doctor's offices, these systems are now mainstream consumer devices. Over time, they evolved to become smaller, digital, wireless, and Internet-connected, an evolution driven by several market trends and forces. One sought to meet the needs and convenience of users for such devices to be wearable, unobtrusive and mobile. Another addressed the need to integrate these devices into a digital data processing environment based on real-time collection and delivery of user data. A third responded to consumer demand for personal health and fitness monitoring devices.

Contested claims 1-3 and 5 of the '698 Patent do not recite anything inventive. Rather, they cobble together what a well-known textbook describes as the "basic building blocks" of optical sensors (Ex.1019 ("BE Handbook"), 765), and combine them in a routine and predictable manner. The claimed systems combine these conventional and common components, including multiple light emitting diodes (LEDs) that generate light at least in the near-infrared range, lenses for directing the light to the skin, a receiver, and standard signal processing techniques.

For example, U.S. 9,241,676 (“Lisogurski”) describes an optical monitor with an LED-based sensor that measures heart rate and various blood constituents. Lisogurski describes various signal processing techniques to extract accurate physiological information from a detected signal in a noisy environment, including modulating the LEDs and techniques for removing ambient light. Other prior art, such as Carlson (Ex.1009), describes conventional techniques used in such optical monitors—such as the use of lenses and the lock-in technique—that a skilled person would have found obvious to use in the analogous devices described in Lisogurski.

The combined teachings of these references describe every element of claims 1-3 and 5, and render those claims unpatentable. Petitioner therefore respectfully requests that trial be instituted and that these claims be cancelled.

## **II. Certifications; Grounds**

### **A. Petitioner May Contest the '698 Patent (§ 42.104(a))**

Petitioner certifies that the '698 patent is available for *inter partes* review (IPR). Petitioner also certifies it is not barred or estopped from requesting IPR of the claims of the '698 patent. Neither Petitioner, nor any party in privity with Petitioner, has filed a civil action challenging the validity of any claim of the '698 patent. The '698 patent has not been the subject of a prior IPR by Petitioner or a privity of Petitioner.

Petitioner also certifies this IPR petition is timely as it was filed less than one year after April 10, 2018, the date Petitioner was first served with a complaint alleging infringement of a claim of the '698 patent. *See* 35 U.S.C. § 315(b); Ex.1004.

**B. Identification of Claims Being Challenged (§ 42.104(b))**

Claims 1-3 and 5 are unpatentable based on the following grounds.

(i) **Claims 1-3 and 5** are obvious under 35 U.S.C. § 103 based on U.S. Patent No. 9,241,676 (“Lisogurski”) (Ex. 1005) and U.S. Patent Pub. 2005/0049468 (“Carlson”) (Ex.1009).

(ii) **Claims 1-3 and 5** are obvious based on Lisogurski, Carlson, and U.S. Patent No. 6,505,133 (“Hanna”) (Ex.1007).

(iii) **Claim 5** is rendered obvious based on Lisogurski, Carlson, and U.S. Patent No. 8,172,761 (Rulkov) (Ex.1014), with or without Hanna.

**C. Fee for *Inter Partes* Review (§ 42.15(a))**

The Director is authorized to charge the fee specified by 37 CFR § 42.15(a) to Deposit Account No. 50-1597.

**D. Service on Patent Owner (§ 42.105)**

Omni MedSci, Inc. is identified as the patent owner of record in the assignment records for the '698 Patent. The named inventor of '698 patent, Dr. Islam, has been a member of the faculty of the University of Michigan since 1992. Ex.1054. Based on the University of Michigan Bylaw 3.10 and Technology

Transfer Policy, the University of Michigan is the owner of the '698 patent.

Ex.1055, Ex.1056 at 21-22. Dr. Islam has also purported to assign the patent to Omni MedSci. *Id.* Petitioner has thus served this petition on both the University of Michigan and Omni MedSci.

### **III. Background Technology**

#### **A. Photoplethysmography**

Optical health monitors use a sensing technique called photoplethysmography (“PPG”) that has been known and used for decades in medical monitoring systems. Ex.1003, ¶37; Ex.1019, 769-76, 1346-55. PPG works by shining light through a person’s tissue and measuring the light that is either reflected back or transmitted through the tissue. Ex.1019, 766. Different components of blood and tissue absorb and reflect different wavelengths of light. Ex.1003, ¶38. By measuring how much light is absorbed and its changes over time, a device can calculate the components of the blood and tissue. Ex.1003, ¶38.

For example, hemoglobin (the substance in blood that carries oxygen to cells) reflects more red light when it is oxygenated and absorbs more red light when it is deoxygenated. Ex.1019, 769; *see* Ex.1003, ¶39. Hemoglobin, however, reflects the same amount of infrared (IR) light whether oxygenated or deoxygenated. Ex.1019, 769. If a device measures the absorbed red and IR light multiple times per second, the device can determine: (i) the ratio of oxygenated to

deoxygenated hemoglobin (oxygen saturation), and (ii) how the volume of blood in the tissue changes over time, allowing detection of a person's pulse. Ex.1019, 769, 771; Ex.1003, ¶39.

PPG is an optical technique that uses conventional optical components. Ex.1003, ¶40. The 1995 BE Handbook explains that the “basic building blocks” of optical sensor systems include lenses, mirrors, filters, beam splitters, light sources, fiber optics, and detectors. Ex.1019, 765. As illustrated in the figure below, light is directed through a lens and onto a sample. Ex.1019, 765. The light reflects back from the sample, is filtered, and sensed by a photodetector. *Id.*; Ex.1003, ¶¶41-43. The photodetector outputs a signal proportionate to the measured light intensity, and then analog-to-digital conversion and signal processing are performed to extract data. Ex.1019, 766. To improve the signal-to-noise ratio, the light source is typically modulated, and the detector uses “synchronized lock-in amplifier detection” to isolate signals that occur at the modulation frequency. Ex.1019, 764, 766. This allows the detector to reduce the noise in the detected signal. Ex.1003, ¶¶44-45.

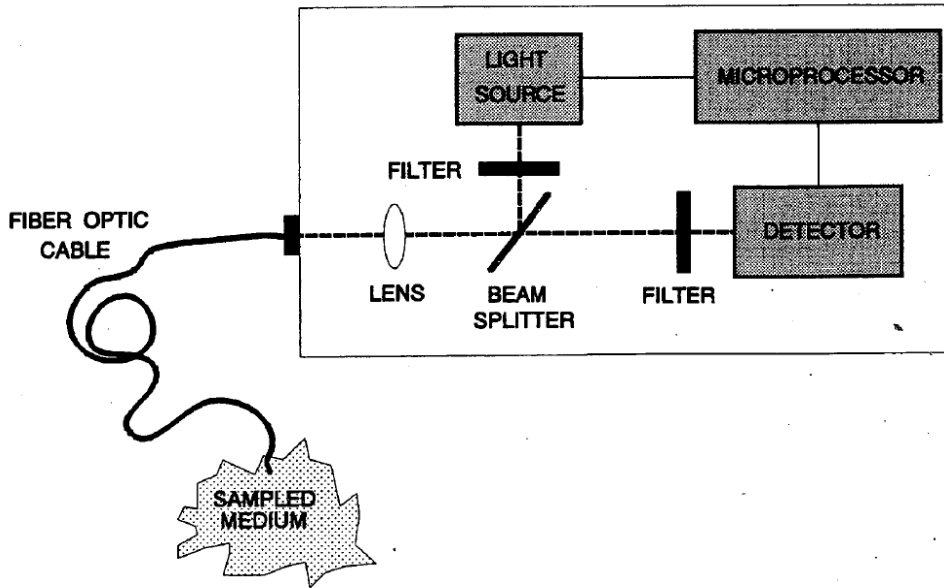

FIGURE 52.1 General diagram representing the basic building blocks of an optical instrument for optical sensor applications.

Portable devices conventionally use light emitting diodes (LEDs) as the light source because LEDs are small and have low power requirements. Ex.1019, 765; Ex.1003, ¶40.

### **B. Prevailing Industry Trends Before 2012**

From 2000 to 2012, several market trends and needs drove the medical device industry to develop wearable, mobile sensor devices that could wirelessly communicate user data to remote devices. Ex.1003, ¶48.

One trend responded to the challenge of providing medical care for patients in their homes or in locations where there was not easy access to a physician. This drove development of wireless monitoring technologies that could be worn by the

patient and used to transmit data to a remote physician or care provider. Ex.1021, 2; Ex.1024, 462; Ex.1027, 15-31; *see* Ex.1003, ¶¶48, 52-53.

Another trend was to bring heart rate sensing devices based on pulsoximetry to the consumer market for personal fitness tracking and other uses. Ex.1003, ¶¶49-50. As a June 2012 review observed:

A multitude of commercial health devices and sensors, such as oximeters and heart rate monitors, formerly reserved for professional use, are now available and can be connected to smartphones. GPS watches, pedometers and heart rate monitors...

Ex.1020, 3; *see also* Ex.1009, [0004] (“Pulsoximetry measuring devices are also used in sports for control and survey of athletes.”); Ex.1029, 221 (“Wristband sensors are a predecessor to smartwatches and remain a successful product category on their own...”); Ex.1005, [0003] (“There is growing market demand for personal health... monitors, for example, for gauging overall health, fitness, metabolism, and vital status during exercise, athletic training...”); Ex.1027, 33, 35.

A third trend sought to take advantage of the miniaturization of electronics and communication technology, which led to the development of smaller, wearable monitoring systems for mobile health and fitness applications. Ex.1021, 3; Ex.1022, 1 *see* Ex.1003, ¶¶51-52.

A fourth trend in the medical industry was to use apps and smartphones to not only deliver care to patients but to give individuals access to health data for

fitness or health issues. This drove integration of miniaturized, network-connected monitoring devices with smartphones and similar devices. Ex.1027, 9-10, 40-49; Ex.1023, 1-2 (“Doctors and nurses were the early adopters of tablets”); Ex.1021, 4; *see* Ex.1023, 5 (One of “the biggest usage of tablets stems from... [p]atient monitoring and data collection..., includ[ing] using the Bluetooth enabled sensor devices and Wi-Fi+ Bluetooth enabled interfaces to patient monitoring devices, to medical instruments that can transmit information to the tablet when in the vicinity.”); Ex.1027, 41; *see* Ex.1003, ¶¶51-52. It also led to the prevalent use of cloud-based data transfer and storage of data. Ex.1003, ¶52.

These market trends provided a strong motivation to skilled persons to integrate medical optical sensing techniques into miniaturized wearable consumer devices that communicate wirelessly with smart devices and remote services. Ex.1003, ¶¶49-50. They also led to a proliferation of products using a distributed architecture supporting personal health, sports, and mobile monitoring systems. Ex.1003, ¶53.

One example of this architecture was described in Patel 2012 (Ex. 1021):

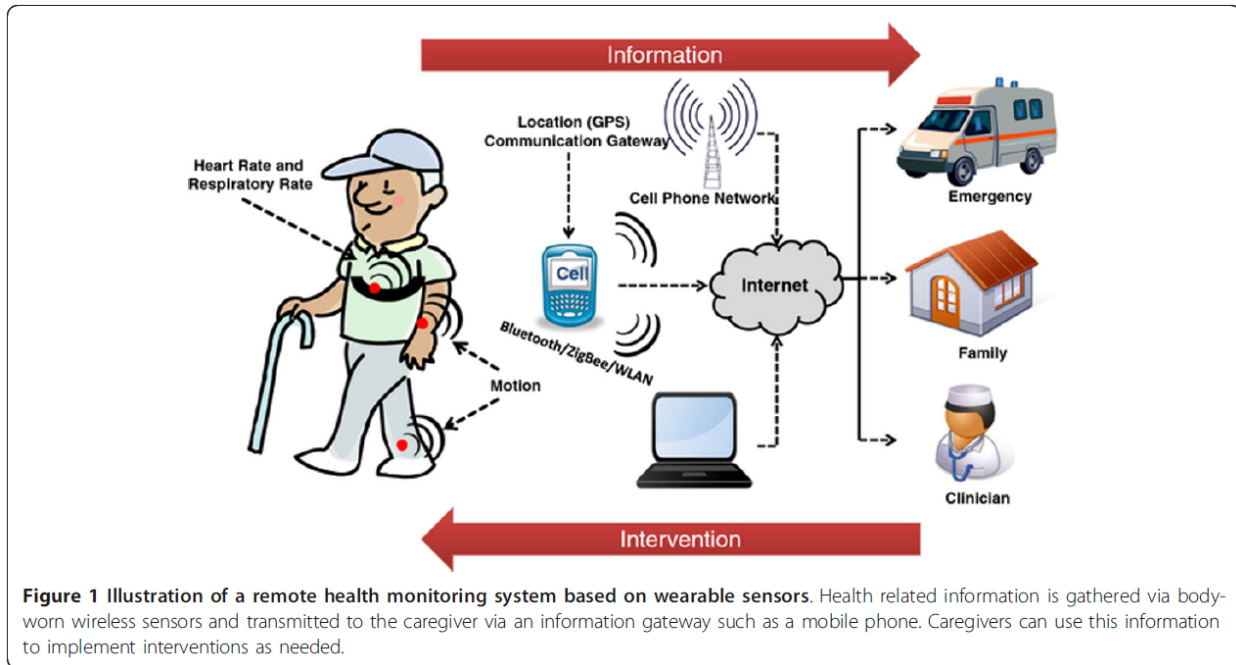

Ex.1021, 2. As this figure illustrates, data from wearable sensors is transmitted to a cell phone, which in turn transmits the data, along with GPS information, to remote devices used by a clinician or maintained by an emergency responder. The data are also shown being transmitted to and stored in the cloud. Ex.1021, 2, 4.

A 2010 publication described a similar architecture in which “medical data can be sent from a wireless monitor to a cell phone or PC and from there to a remote physician.” Ex.1024, 459. As depicted, it comprised three network-interconnected components: (i) the “sensor” device on the person that collected physiological data, (ii) a host device such as a smartphone, tablet, or computer that wirelessly captured and transmitted the physiological data, and (iii) a remote web service accessible over the Internet. Ex.1024, 460; Ex.1003, ¶54.

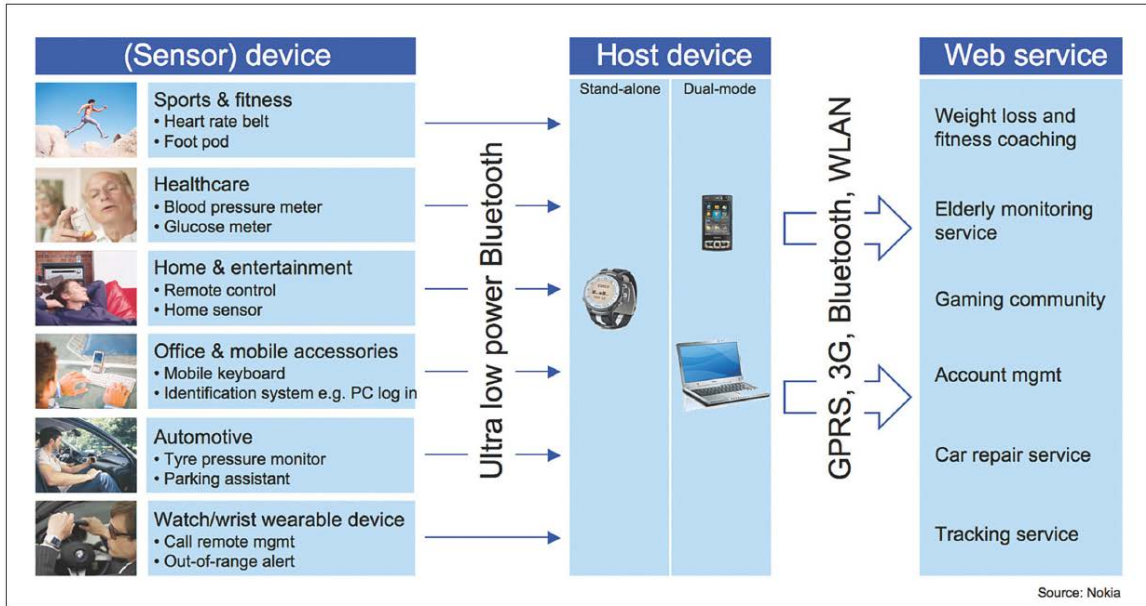
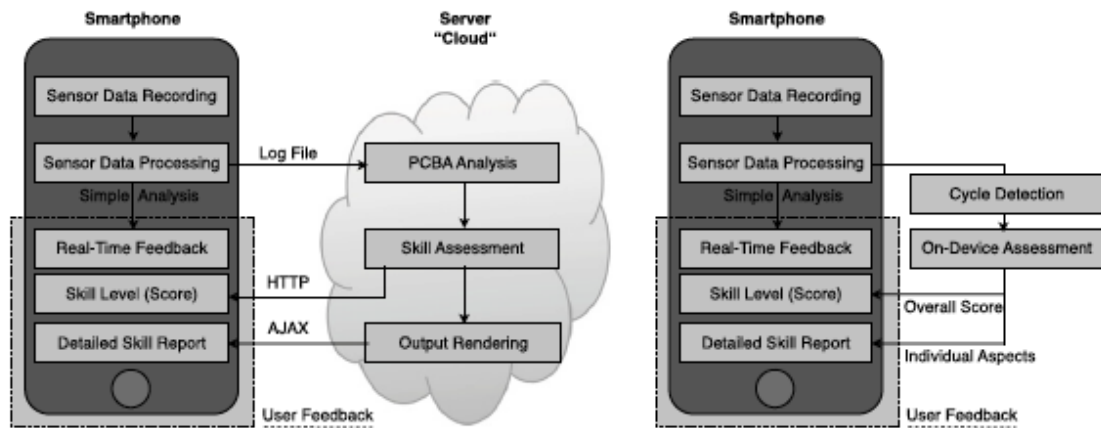

Figure 2. Bluetooth low energy will extend interoperable wireless connectivity to coin-cell-powered wireless sensors in health care, fitness, and related sectors. WLAN, wireless local area network; GPRS, general packet radio service.

Other articles from around 2012 similarly envisioned use of “cloud” based services to support this interconnected scheme. Ex.1003, ¶155. A 2012 article illustrated a cloud-based architecture implemented as a fitness app as follows:



(a) Iteration 1: the smartphone records sensor data during exercising, which are processed by a server after the training to generate skill assessment.

(b) Iteration 2: data is processed on the phone for real-time feedback as well as sophisticated feedback addressing individual aspects after the execution.

Fig. 3. Iterations of the GymSkill application.

Ex.1020, 7. In this example, a smartphone records and processes sensor data, then sends the data to a cloud server for further processing, and then the cloud server returns processed data back to the smartphone for display to the user. Ex.1020, 6-7, 12. This same article specifically recognized this type of system could be used with heart rate monitors and optical sensors.

**IV. The '698 Patent**

**A. Illustrative Claim**

Independent claim 1 defines a wearable device comprising a number of well-known components of optical sensing systems. Claim 1, the only challenged independent claim and is reproduced in the attached claim appendix.

**B. The '698 Patent and Its Prosecution**

The '698 Patent issued from U.S. Application No. 15/212,549, which claims benefit or priority to a series of earlier filed applications (shown below):

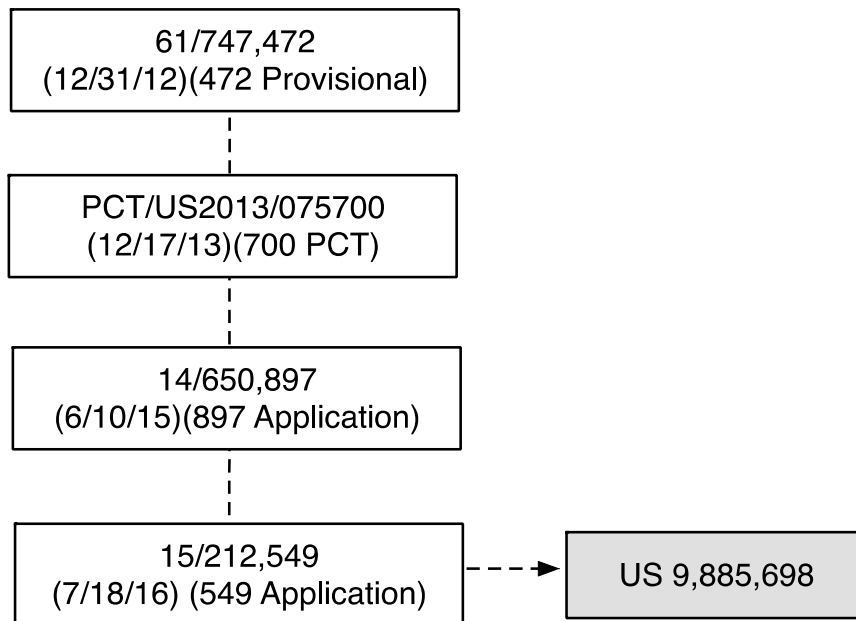

The '549 Application, like the '897 Application and the '700 PCT, claim the benefit of a single application—U.S. Provisional Application No. 61/747,472 (the '472 Provisional). Ex.1001, 1:9-23; Ex.1002, 11.

The '549 application and its two predecessors also state they are “related to” a series of provisional applications, including, *inter alia*, 61/747,477 ('477 provisional) and 61/747,485 ('485 provisional). Ex.1002, 11. None of those provisionals was made the basis of a priority claim under 35 U.S.C. § 119(e).

### **C. The '698 Patent Is Subject to AIA**

Claims 1-3 and 5 of the '698 Patent are not entitled to priority to the '472 provisional filed on December 31, 2012. As the '698 patent has no other basis for an effective filing date prior to March 16, 2013, it is subject to the first-to-file provisions of the AIA.<sup>1</sup>

To be entitled to priority to an earlier filed application, the claimed subject matter must be supported in the manner required by 35 U.S.C. § 112 by the disclosure of the earlier application. *Hologic, Inc. v. Smith & Nephew, Inc.*, 884 F.3d 1357, 1361 (Fed. Cir. 2018). Among other things, the earlier application's disclosure must establish the inventors had possession of the invention *as it is later claimed*—it is not sufficient if the earlier disclosure simply makes the claimed

---

<sup>1</sup> Pub. L. 112-29, §3(n); *see* MPEP 2159.02.

invention obvious. *Lockwood v. American Airlines*, 107 F.3d 1565, 1572 (1997) (“One shows that one is ‘in possession’ of the invention by describing the invention, with all its claimed limitations, not that which makes it obvious.”).

Here, the ’472 provisional does not demonstrate possession of a wearable device defined by claims 1-3 and 5 having a measurement device comprising a receiver that:

- is configured to use a lock-in technique; and
- has multiple spatially separated detectors that: (i) capture a first signal while the LEDs are off, (ii) capture a second signal when at least one of the LEDs is on, and (iii) improve the signal-to-noise ratio of the reflected input optical beam by differencing the first and second signals.

No passages in the ’472 provisional provide written description support for these “lock-in” or “differencing” elements of claims 1-3 and 5. This can be appreciated by observing that passages in the ’698 patent concerning these elements are absent in the ’472 provisional. *See, e.g.*, Ex.1001, 14:36-38, 14:40-44, 21:51-55 (“lock-in”); *id.*, 14:44-51 (“differencing” signals); Ex.1003, ¶31. Because the ’472 provisional does not provide written description support for the claims as required by § 112 as of its filing date, claims 1-3 and 5 may not properly claim priority to the ’472 provisional.

Importantly, the '549 application itself did not contain these passages when it was filed. Ex.1002, 56. Instead, the '549 specification was amended on May 4, 2017 to add ¶ 0077-1 and later, on June 8, 2017 to add ¶ 0103-1. Both additions added for the first time text to the specification concerning the “lock-in” and “differencing” elements of claims 1-3 and 5. Ex.1002, 528, 545-546. In each case, Patent Owner justified the additions as proper amendments because the added text was found in the earlier-filed '477 and '485 provisionals that Patent Owner contended had been “incorporated by reference.”

Notably, applicant cannot rely on provisional applications that were incorporated by reference, but to which priority was not claimed, to provide written description support for the claims. Any such disclosure is “essential material” that may only be incorporated by reference via “a U.S. patent or U.S. patent application *publication*... which ‘does not itself incorporate such essential material by reference.’” 37 C.F.R. § 1.57(d);<sup>2</sup> *Droplets, Inc. v. E\*TRADE Bank*, 887 F.3d 1309, 1319 (Fed. Cir. 2018) (claim amendments can transform nonessential material into essential material, causing a § 112 violation). A

---

<sup>2</sup> All emphases added unless otherwise noted.

provisional application cannot be a “U.S. patent application publication” specified in Rule 57(d) because it is never published.<sup>3</sup>

Patent Owner may contend the added material is not “essential material.” Plainly it is—it corresponds to specific claim elements, and is the only text in the ‘698 Patent corresponding to these elements.

Regardless, Patent Owner may not rely on disclosures in the ‘477 or ‘485 provisionals *for any purpose* before the date on which they were incorporated by reference into the disclosure of an application to which the ‘698 Patent makes a valid claim of benefit or priority. The earliest date when this occurred was December 17, 2013, when applicant filed its PCT application.<sup>4</sup>

---

<sup>3</sup> A “patent application publication” is a non-provisional application filed under 35 U.S.C. §111(a) that has been published pursuant to 35 U.S.C. §122(b). A provisional patent application cannot be a patent application publication because it is filed under 35 U.S.C. §111(b) and is expressly excluded from publication under §122(b). *See* 35 U.S.C. §§122(b)(1), (b)(2)(A)(iii); 37 C.F.R. 1.215; M.P.E.P. 1121 (defining contents of a “patent application publication”); M.P.E.P. 903.04.

<sup>4</sup> Petitioner reserves its right to dispute any assertion by Patent Owner that the claims are entitled to priority earlier than December 17, 2013.

**D. Person of Ordinary Skill in the Art**

A person of ordinary skill in the art (“skilled person”) would have a good working knowledge of optical sensing techniques and their applications, and familiarity with optical system design and signal processing techniques. That knowledge would have been gained via an undergraduate education in engineering (electrical, mechanical, biomedical or optical) or a related field of study, along with relevant experience studying or developing physiological monitoring devices (e.g., non-invasive optical biosensors) in industry or academia. Ex.1003, ¶35. This description is approximate; varying combinations of education and practical experience also would be sufficient. *Id.*

Apple’s positions regarding how a skilled person would have understood the ’698 Patent claims and the prior art are supported by the testimony of Brian Anthony, Ph. D., an expert in optical sensing devices with over 20 years of experience. *Id.*, ¶¶1-9, 36.

**V. Claim Construction**

The parties in related district court litigation agreed that the claim language should be given its plain and ordinary meaning, except for three terms. The parties offered alternative constructions for these terms, and the Court provided a

preliminary construction of each disputed term. *See* Ex.1043 (the parties' claim constructions), Ex.1045 (preliminary claim construction).<sup>5</sup>

To avoid any dispute linked to claim scope, the grounds in this petition demonstrate the claims are unpatentable using the narrowest construction for each disputed claim term.<sup>6</sup> For "beam," that is Apple's proposed construction of "photons or light transmitted to a particular location in space." For "one or more lenses," the narrowest construction is Apple's proposed construction of "one or more transparent surfaces used to collimate (make parallel) or focus rays of light." For "modulating at least one of the LEDs," the narrowest construction is the district court's preliminary construction of "varying the amplitude, frequency, or phase of the light produced by at least one of the LEDs to include information." As explained below, these constructions are faithful to the patentee's lexicography, the specification, and the extrinsic evidence.

---

<sup>5</sup> The district court has not yet provided a final claim construction order, which is expected to issue in the next few months. Petitioner will file the final claim construction as an exhibit when the order issues.

<sup>6</sup> If Patent Owner contends that special constructions should be used that are different from those it has advanced in the co-pending litigation, Petitioner may request leave to file a reply to such assertions.

**A. “Beam”**

The claim term “*beam*” is expressly defined in the specification: “As used throughout this disclosure, the terms ‘optical light’ and or ‘optical beam’ and or ‘light beam’ refer to photons or light transmitted to a particular location in space.” Ex.1001, 9:29-31. This definition should be adopted verbatim as the patentee’s chosen lexicography. *Sinorgchem Co., Shandong v. Int’l Trade Comm’n*, 511 F.3d 1132, 1136 (Fed. Cir. 2007) (patentee who acts as his own lexicographer is bound by his definition). The definition is also consistent with extrinsic evidence reflecting that a skilled artisan would understand a “beam” to mean “a collection of nearly parallel rays.” Ex.1047 at 106; *see also* Ex.1042 at 1. Such a collection of nearly parallel rays would necessarily travel to a particular location in space, as opposed to scattering in different directions. *See* Ex.1001, 10:42-47 (distinguishing a beam from “stray light from a reflection or scattering”), 24:12-14 (directing an array of beams), and 6:18-22 (delivering a beam to a sample). The district court’s preliminary construction recognized that a beam does not include randomly directed light.

Therefore, “*beam*” should be construed to mean “photons or light transmitted to a particular location in space.”

**B. “One or more lenses”**

The only type of lens described by the '698 Patent is one that will “collimate or focus the light.” Ex.1001, 20:57-58, 21:22-24, 23:40-42. Consistent with this, the claims specify the lenses are “configured to receive and to deliver a portion of the input optical beam to tissue.” To perform these claimed functions, the lens must be transparent so that the received light can pass through the lens and travel to the tissue. And, in order to deliver the received beam the lens must collimate or focus the beam, rather than scatter the beam. These defining characteristics of the claimed lens are consistent with the dictionary definition of a lens:

a piece of transparent material (as glass) that has two opposite regular surfaces either both curved or one curved and the other plane and that is used either singly or combined in an optical instrument for forming an image by focusing rays of light.

Ex.1046 at 712; Ex.1041 at 481 (“[a] piece of glass or other transparent material”).

Therefore “*one or more lenses*” should be construed to mean “one or more transparent surfaces used to collimate (make parallel) or focus rays of light.”

**C. “Modulating at least one of the LEDs”**

The district court did not adopt either party’s proposed construction for “*modulating*” and instead proposed the following preliminary construction: “varying the amplitude, frequency, or phase of the light produced by at least one of the LEDs to include information.” This construction adopts definitional language in the '698 Patent stating that beams “may be modulated or unmodulated, *which*

*also means that they may or may not contain information.”* Ex.1001, 9:32-34. It also is consistent with extrinsic evidence relied on by both parties, including a dictionary definition both parties employed:

To vary the amplitude, frequency, or phase of (carrier wave or a light wave) for the transmission of information (as by radio).

Ex.1046, 798; *see also* Ex.1039, 14-15 (describing modulation in the context of AM and FM radio used to transmit audio information).

At the Markman hearing, Petitioner urged the Court to revise its preliminary construction to delete “amplitude” because the specification and claims distinguish modulating from varying the amplitude of the signal. Ex.1044, 21:16-22:1.

Petitioner observes that whether “amplitude” is included in the construction of modulating ultimately has no consequence in this proceeding as the prior art renders the claims unpatentable even under this narrower construction. For simplicity, Petitioner proposes that the Board use the district court’s preliminary construction in this proceeding, with the express reservation that Petitioner may argue the narrow construction in district court.

## **VI. Detailed Explanation Why the ’698 Patent Claims Are Unpatentable**

### **A. Lisogurski and Carlson Render Obvious Claims 1-3 and 5**

#### **1. Overview of Lisogurski**

Lisogurski was filed on May 31, 2012, and issued on January 26, 2016. It is prior art under 35 U.S.C. § 102(a) and (d) (AIA) or § 102(e) (pre-AIA).

Lisogurski describes a portable physiological monitoring system that uses a wearable optical sensor to measure a person's pulse rate and oxygen saturation (*e.g.*, a pulse oximetry system). Ex.1011, 3:66-4:8. The system includes a sensor, a monitor, and remote devices such as a server. Ex.1011, 11:28-32, 15:43-48; Ex.1003, ¶72. The sensor can be worn in various locations, such as on a fingertip or wrist, Ex.1011, 4:6-8, 4:15-20, is battery powered, and can wirelessly communicate with the monitor, Ex.1011, 17:55-58; Ex.1003, ¶73. The sensor can include several light emitting diodes (LEDs) and photodetectors. Ex.1011, 17:37-45, 10:48-64, 11:9-13.

The system regulates a light drive signal, which is the electric current that is applied to the LEDs. Ex.1011, 11:38-41, 11:50-54, 12:3-9; Ex.1003, ¶75. For a particular LED, the emitted light intensity increases as a higher current is applied. Ex.1011, 12:3-9, 12:16-22, 7:13-16, 7:24-31. Lisogurski teaches that the LEDs can be modulated. Ex.1011, 4:48-54, 8:4-8, 8:27-35, 16:25-32. Depending on various conditions, the device can change the modulation parameters and the light drive cycle. Ex.1011, 1:60-61, 1:67-2:3. The drive cycle parameters that can be controlled include “light intensity, duty cycle, [and] light source firing rate.” Ex.1011, 1:60-61, 1:67-2:3; *see id.*, 1:19-21, 5:48-54, 25:53-55. Lisogurski explains that varying the drive cycle parameters can increase the signal-to-noise

ratio of the device when interference is encountered. Ex.1011, 5:55-6:6, 9:46-52, 27:44-49; Ex.1003, ¶77.

The modulated light emitted by the LEDs is passed into a person's tissue and the light reflected back is detected by a photodetector. Ex.1011, 4:7-11, 10:48-56, 11:13-20; Ex.1003, ¶76. The detector "convert[s] the intensity of the received light into an electrical signal." Ex.1011, 11:14-16. Lisogurski teaches that the sensor can send the detected signal directly to the monitor or it can pre-process the signal first. Ex.1011, 11:20-27. It also shows that the sensor can be connected to the monitor with a wire or cable, or it can be "wirelessly connected to [the] monitor." Ex.1011, 17:54-59, Fig. 3. Either way, the device applies signal processing techniques to the detected signal to isolate the signal from the reflected light. Ex.1011, 7:16-21, 12:48-49; *see generally id.*, 13:7-14:55 (describing various signal processing).

## 2. Overview of Carlson

Carlson is a U.S. Patent Application published on March 3, 2005, and is prior art under 35 U.S.C. § 102(a) and (b) (AIA and pre-AIA). Carlson describes a wearable pulse oximeter that can be worn on the ear, finger, toe or "other parts of the human body." Ex.1009, [0052], [0075]; Ex.1003, ¶80. The device uses a conventional sensor known in "the state of the art" that emits optical wavelengths in the red (*e.g.*, 660 nm) and infrared (*e.g.*, 800 to 1000 nm) ranges, and it detects

light that has been transmitted or reflected. Ex.1009, [0003], [0050], [0052]. The device is mobile and can wirelessly transmit data to a doctor or hospital. Ex.1009, [0072], [0077]-[0078]; Ex.1003, ¶80.

Carlson's objective is to describe techniques for "increasing the technical performance of pulsoximetry in terms of quality and robustness of the measurement signal versus environmental disturbances and energy consumption." Ex.1009, [0002]; *see* Ex.1003, ¶81. Carlson notes that while known sensors can be used in telemedicine, athletics, and other mobile applications, these standard sensors "suffer from signal instability and insufficient robustness versus environmental disturbances." Ex.1009, [0004]. Carlson therefore has the objective "to define optical and/or electronic means for increasing the Signal-to-Noise ratio (S/N)... of a pulsoximeter sensor for robust application of pulsoximetry in telemedicine and near patient testing applications in rough (optical) environmental conditions, e.g. at changing light influences, such as sunlight, shadow, artificial light, etc." Ex.1009, [0010]. These observations in Carlson provide a direct motivation to a skilled person to incorporate its techniques, features and other improvements into other pulsoximetry devices. Ex. 1003, ¶85.

### **3. A Skilled Person Would Have Modified Lisogurski to Incorporate Elements Shown in Carlson**

A skilled person would have considered the systems described in Lisogurski in conjunction with those described in Carlson, as both concern analogous

miniaturized wireless puloximetry devices having the same applications (*e.g.*, mobile monitoring of pulse and other physiological characteristics of a person).

Ex.1003, ¶86.

Lisogurski describes a PPG system that is designed to optimize power consumption. Ex.1011, 1:4-6, 3:50-53. Its system allows “for increased battery life” and “[for] increased portability.” Ex.1011, 1:16-18. As an example, Lisogurski explains that its techniques could improve oximeters by reducing power requirements, allowing for smaller devices or longer life. Ex.1011, 4:63-67. Lisogurski describes these improvements in a system that includes a wearable sensor, *e.g.*, one worn on a wrist. Ex.1011, 4:15-20, 17:51-58. Lisogurski teaches several techniques for increasing the signal-to-noise ratio of measured signals while minimizing power consumption. Ex.1011, 9:46-52. As Dr. Anthony explains, these teachings would motivate a skilled person to look for other techniques for achieving the same objectives, particularly those used with wearable sensors. Ex.1003, ¶¶83-86. A skilled person would do that as part of the ordinary design process he or she follows to improve the operation of a device; they naturally would look to complementary designs and techniques in analogous systems. Ex.1003, ¶84.

That would have led the skilled person to Carlson, which describes techniques for improving pulse oximetry devices by improving both signal

measurement and energy consumption. Ex.1009, [0002]; Ex.1003, ¶85. Carlson teaches techniques and structures for increasing the signal-to-noise ratio of the optical sensing performed by such devices, even where optical conditions of the environment are changing. Ex.1009, [0010]. Carlson indicates its techniques are energy efficient and can be used in battery-powered devices, such as those worn on an earlobe or finger. Ex.1009, [0048], [0052]. Carlson describes incorporating its techniques in devices used for hospital patients, for mobile monitoring and telemedicine, and for sports applications to monitor athletes. Ex.1009, [0004].

Lisogurski and Carlson thus describe analogous systems with common applications and utility; both describe techniques for improving the power consumption of portable and wearable optical sensing devices while improving their performance and utility. Ex.1003, ¶86. The skilled person would have considered the references together when implementing a system based on Lisogurski's teachings. Ex.1003, ¶86.

Moreover, as explained in §III.B, above, by 2012, there was a general trend in the industry to create wearable devices that can be used in mobile monitoring situations or for sports and personal fitness applications. Ex.1003, ¶¶48-56. Thus, the skilled person considering Lisogurski would have had reason to look to references describing techniques for creating or improving wearable devices for

these mobile health and consumer applications, such as Carlson. Ex.1003, ¶¶87-88.

The skilled person also would have been motivated to include specific features from Carlson in Lisogurski's system, for the reasons set forth below.

#### **4. Theoretical Distinctions Between Lisogurski and Claims 1-3, and 5**

As explained below, Lisogurski describes systems having nearly all of the elements of the systems as they are defined by the contested claims. Patent Owner may, however, contend that certain distinctions exist between those claims and the systems described in Lisogurski. For independent claim 1 (from which all the other claims depend), these theoretical distinctions include whether Lisogurski discloses:

- “lenses”;
- use of a “lock-in technique”;
- use of “modulation” under the district court's construction;
- that its sensor alone includes every component of the measurement device in the claims (e.g., that the claims require the photodetectors and the circuitry that controls them to be physically integrated into a single component).

One other theoretical distinction is with respect to dependent claim 5, which specifies that a wearable device interact with a smart phone or tablet.

Each of these supposed distinctions would be inconsequential to patentability, as a skilled person would have considered each to have been an obvious variation of the systems being described in Lisogurski at the time of the invention. That is because each represents a conventional, logical and predictable design alternative to what is depicted in Lisogurski based on the guidance in Lisogurski, especially when considered with Carlson's teachings. Consequently, independent claim 1, as well as claims 2-3, and 5 would have been obvious to a skilled person based on Lisogurski in view of Carlson.

## **5. Independent Claim 1**

### **a) Preamble**

The claim 1 preamble specifies "*a wearable device.*"

Lisogurski teaches a sensor that may be worn on various portions of a person's body, including "a fingertip... earlobe..., the wrist... and around or in front of the ear." Ex.1011, 4:6-20. The sensor is battery-powered and "may be wirelessly connected to [a] monitor." Ex.1011, 17:55-59 ("Sensor unit 312 may be powered by an internal power source, e.g., a battery..."). Thus, the sensor is a "*wearable device.*"

**b) “a measurement device...”****(1) “...for measuring one or more physiological parameters...”**

Lisogurski explains that its sensor is part of “an optical physiological monitoring system” that “may be used to *determine physiological parameters* such as blood oxygen saturation, hemoglobin, blood pressure, pulse rate, other suitable parameters, or any combination thereof.” Ex.1011, 1:10-25<sup>7</sup>; *id.*, 3:43-46; *see also id.*, 3:61-4:5, 4:22-25, 15:30-35. Thus, the sensor is a device “*for measuring... physiological parameters.*”

**(2) “...including a light source comprising a plurality of light emitting diodes (LEDs)..., the measurement device configured to generate, by modulating at least one of the LEDs having an initial light intensity, an input optical beam having one or more optical wavelengths, wherein at least a portion of the one or more optical wavelengths is a near-infrared wavelength between 700 nanometers and 2500 nanometers”**

Lisogurski describes a wearable sensor that can include a light source comprising multiple LEDs (“*a plurality of ... light emitting diodes...*”). Ex.1011, 17:42-45 (“In an embodiment, sensor unit may include multiple light sources and detectors.”), 10:48-49, 10:58-64 (“light source 130 may include any number of light sources with any suitable characteristics”); Fig. 1 (130); Fig. 3 (316).

---

<sup>7</sup> All emphases are added unless otherwise noted.

Lisogurski indicates that each of the LEDs is configured to output a different optical wavelength. Ex.1011, 7:38-8:3 (“the first light source may be a[n]... infrared (IR) LED while the one or more additional light sources may be... red LEDs”). The light source may include any number of LEDs, such as multiple IR LEDs and multiple red LEDs. Ex.1011, 10:58-63, 17:37-45, 19:25-31; Ex.1003, ¶¶94-95.

Lisogurski further explains that the LEDs are “configured to emit photonic signals having one or more wavelengths of light (e.g., Red and IR) into a subject’s tissue” (“*an input optical beam with one or more wavelengths*”). *Id.* 10:49-52; *see id.*, 4:42-45. The LEDs are configured to direct the light “into a subject’s tissue,” (Ex.1011, 10:49-52), and thus, they create light “transmitted to a particular location in space” as required by the term “*beam.*” Ex.1003, ¶97. It also explains that “the IR wavelength may be between about 800 nm and about 1000 nm” (“*at least a portion of the one or more wavelengths is a near-infrared wavelength between 700 nanometers and 2500 nanometers*”). *Id.*, 10:56-58.

Lisogurski explains that the LEDs have an initial brightness level (“*an initial light intensity*”) that the system may adjust. 5:67-6:6 (“the system may reduce emitter brightness... the system may increase the emitter brightness.”).

Each of the LEDs may be modulated. Ex.1011, 7:38-40 (“the system may *modulate* multiple light sources using *a plurality of modulation techniques*”)),

5:2-7, 5:48-61 (“drive cycle *modulation*’... will refer to a relatively *higher frequency modulation technique*...”), 5:25-47 (cardiac cycle “modulation [is] aligned with pulses of the heart”), 6:31-38 (“the system may use *various cardiac cycle modulation schemes*... [including by] using a periodic waveform... [that] may be substantially related to the cardiac pulse rate”), 8:16-44; Ex.1003, ¶96.

Lisogurski explains that light drive circuitry controls the modulation, and can alter the LED light drive parameters, such as “drive current or light brightness, duty cycle, [and] *firing rate*” amongst others. Ex.1011, 27:44-52; *id.*, 2:1-2 (“light source firing rate”), 8:29-35, 25:49-55. Lisogurski explains that the firing rate or frequency of the LEDs can change over time, and can, for example, be correlated to the sampling rate of an analog-to-digital converter. Ex.1011, 33:47-49 (“sampling rate modulation may be correlated with light drive signal modulation”); *see also, id.*, 11:43-46; 11:52-55. Lisogurski explains “the time between ‘on’ periods [for an LED] may be the length of time of ‘off’ period 220 of FIG. 2A... [D]ecreasing the duration of the ‘off’ periods (i.e., *increasing the emitter firing rate*) relates to an increased sampling rate.” Ex.1011, 35:27-31. Thus, Lisogurski teaches that the LED firing rate or frequency can change. Ex.1003, ¶98. Thus, Lisogurski teaches varying the frequency of the LEDs, as required by Apple’s district court construction of “*modulation*.”

Lisogurski explains that its “system may *modulate* multiple light sources using *a plurality of modulation techniques*.” Ex.1011, 7:38-40. For example, Lisogurski discloses that one such technique is code division multiplexing (CDM). Ex.1011, 6:19-24. In CDM, each channel has a unique code and that code is embedded into the signal for that channel. Ex.1003, ¶¶100, 45. The skilled person would have understood that use of CDM would embed information in the signal in the form of a unique code for each LED or channel of light. Ex.1003, ¶100. Thus, Lisogurski teaches embedding information in the signal as required by the district court’s preliminary construction of “*modulation*.”

Thus, Lisogurski describes this element of claim 1.

- c) **“the measurement device comprising one or more lenses configured to receive and to deliver a portion of the input optical beam to tissue, wherein the tissue reflects at least a portion of the input optical beam delivered to the tissue”**

Lisogurski teaches using conventional red and infrared LEDs to emit an output optical beam, Ex.1011, 10:53-56, 7:38-8:3, and that each sensor can include multiple LEDs of each wavelength, Ex.1011, 19:25-31. A person of ordinary skill would have known that a conventional LED is comprised of a light emitting semiconductor that creates the light, and that the semiconductor typically is encapsulated in glass or another medium. Ex.1003, ¶¶110-11. The encapsulant can be used to protect the semiconductor, but it also commonly is shaped as a lens

to focus the light emitted by the LED. Ex.1003, ¶¶46, 111. Thus, a person of ordinary skill would understand that each LED includes a lens. Ex.1003, 113.

As Dr. Anthony explains, the POSA would have known there are three types of LEDs: (i) LEDs with no encapsulant, (ii) LEDs with an optically inert encapsulant, and (iii) LEDs with an encapsulant that acts as a lens. Ex.1003, ¶112; *see* Ex. 1035, 97-98, 191-99, 266-67. The lens helps direct more of the light produced by the LED outward toward the tissue (and thus “transmit[] [the light] to a particular location in space”), increasing its efficiency, which is important in a mobile, battery-powered device. Ex.1003, ¶113. The skilled person would have found it obvious to select an LED that uses an encapsulant that functions as a lens, as this was a common configuration. Ex.1003, ¶113. In this configuration, each of Lisogurski’s LEDs would emit a portion of an “*input optical beam*,” which would be captured by that LED’s encapsulant lens and focused on the tissue. Ex.1003, ¶114.

Thus, Lisogurski describes “*one or more lenses configured to receive and to deliver a portion of the input optical beam to tissue.*”

As noted above (§VI.A.4), Omni may contend that Lisogurski does not disclose lenses. Even if that distinction were accepted, it would be inconsequential, because the skilled person would have found it obvious to include

that element in Lisogurski based on that person's knowledge as well as on Carlson. Ex.1003, ¶¶116-17.

As described in §III.A, above, a skilled person considering Lisogurski would have known that a lens is a “basic building block” of an optical sensor (Ex.1019, 765) and that lenses commonly were part of such sensors. Ex. 1003, ¶115. That person also would have found it obvious to include a separate lens for each LED in Lisogurski's sensor, given that lenses were standard components of optical sensors. Ex.1003, ¶115. Thus, to the extent Lisogurski's LEDs do not suggest the use of lenses (“transparent surfaces used to collimate (make parallel) or focus rays of light” per Apple's construction), using a lens for each LED would have been obvious based on a POSA's knowledge. Ex.1003, ¶116.

Carlson independently identifies the benefits of using lenses within optical sensing devices of the type described in Lisogurski. Carlson teaches use of a plurality of lenses – it calls for use of “at least one beam shaping optical element to direct the emitted light” towards a sample (Ex.1009, [0013]) and that the beam shaping element can be “diffractive or refractive lenses, to direct the emitted optical radiation of, e.g., the LED light source into the human... tissue.” Ex.1009, [0013], [0014], [0024], [0062]. A “refractive lens” is one that focuses rays of light, and thus, it meets Apple's construction of “*lens*.” Ex.1003, ¶118. Figure 4 shows two lenses 21 receiving light beams 8 emitted by LEDs 15 (“*receive... a portion of*

*the input optical beam*”) and delivering light bundles or beams 12 to ear tissue 2 (“*deliver a portion of the input optical beam to tissue*”). Ex.1009, [0054], [0062].

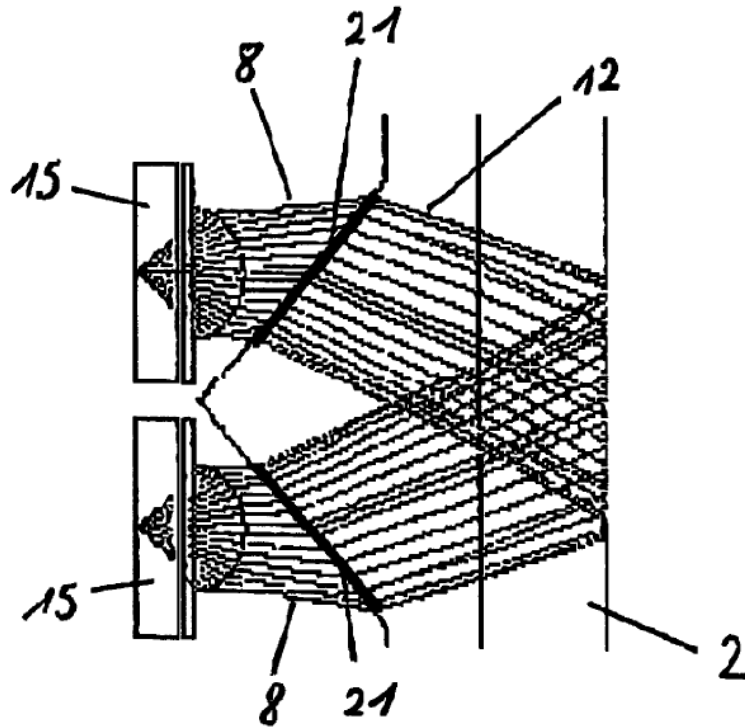

Figure 4

Ex.1009, Fig.4; *id.*, [0054] (“in Fig. 4, using the beam shaping optics 21, the two initial light beams 8 are guided in the form of bundled beams 12”). Thus, as the figure shows, the light within each beam is “transmitted to a particular location in space” and meets Apple’s construction of the term “*beam.*” Ex.1003, ¶¶118-19.

A skilled person would have considered it obvious to include a plurality of lenses as described in the Carlson device in Lisogurski’s sensor for the reason Carlson identifies—to focus the light emitted by each of the LEDs onto a person’s skin. Ex.1003, ¶120. Carlson identifies a benefit of doing so—lenses increase the

optical signal power without increasing the actual power used by the system.

Ex.1009, [0014] (“The basic idea... is to use *a beam-shaping element, such as e.g., ... lenses*..., in order to increase the optical signal power..., thus increasing the Signal/Noise ... ratio.”); *id.*, [0010].

The skilled person also would have been motivated to include lenses in the Lisogurski device. Ex.1003, ¶119. One of Lisogurski’s objectives is to improve the power consumption efficiency of optical sensing devices, including by improving the signal-to-noise ratio of the measured optical signal. Ex.1011, 6:3-6, 9:49-60, 13:60-14:10, 14:40-55, 37:6-20; Ex.1003, ¶119. The skilled person would have recognized that adding lenses to Lisogurski as Carlson teaches would achieve that objective as they improve the signal-to-noise ratio without using additional power and complement operation of the Lisogurski system. Ex.1003, ¶119. The skilled person also would have known that lenses are one of the “basic building blocks” of optical sensors, (Ex.1019, 765) and would be able to integrate them into Lisogurski with routine effort (Ex.1003, ¶120). *See* §III.A, above. A skilled person thus would consider adding lenses to Lisogurski’s sensor to be a predictable arrangement of known elements, with each performing the same function it was known to perform and yielding what one would expect from the arrangement. Ex.1003, ¶¶120-21.

Thus, Lisogurski and Carlson render obvious “*one or more lenses configured to receive and to deliver a portion of the input optical beam to tissue.*”

In either configuration that includes lenses, the tissue reflects at least a portion of the emitted light back to a photodetector. Lisogurski explains that the detectors receive “the light that is reflected by or has traveled through the subject’s tissue.” Ex.1011, 17:40-42; 11:12-20 (“In operation, *light may enter detector 140 after passing through the subject's tissue... The light intensity may be directly related to the... reflectance of light in the tissue.*”).

Thus, Lisogurski and Carlson render obvious “*wherein the tissue reflects at least a portion of the input optical beam delivered to the tissue.*” Ex.1003, ¶122.

**d) “the measurement device further comprising a receiver, wherein the receiver includes a plurality of spatially separated detectors”**

Lisogurski’s sensor includes “[o]ne or more detector 318... for detecting the light that is reflected by or has traveled through the subject’s tissue.” Ex.1011, 17:40-42; *see also id.*, 11:9-10; Fig. 1 (140); Fig. 3 (318). The sensor “may include multiple light sources and detectors, which may be spaced apart.” Ex.1011, 17:43-45. Each detector “converts the intensity of the received light into an electrical signal.” Ex.1011, 11:14-16; 11:20-22; Figs. 1, 3. Thus, Lisogurski teaches “*a plurality of spatially separated detectors.*” Lisogurski also teaches that

“[a]fter converting the received light to an electrical signal, detector 140 may send the detection signal to monitor 104.” Ex.1011, 11:20-22.

The detector described in Lisogurski is connected to front end processing circuitry (together, “a receiver”), which “may receive a detection signal from detector 140 and provide one or more processed signals to back end processing circuitry 170.” Ex.1011, 12:42-45; Ex.1003, ¶¶123-25. The detectors generate electrical signals that are received by the front end processing circuitry, and those signals are passed between the components of the circuitry. Ex.1011, 13:6-60.

These components are depicted in Figure 1 (annotations added) of Lisogurski:

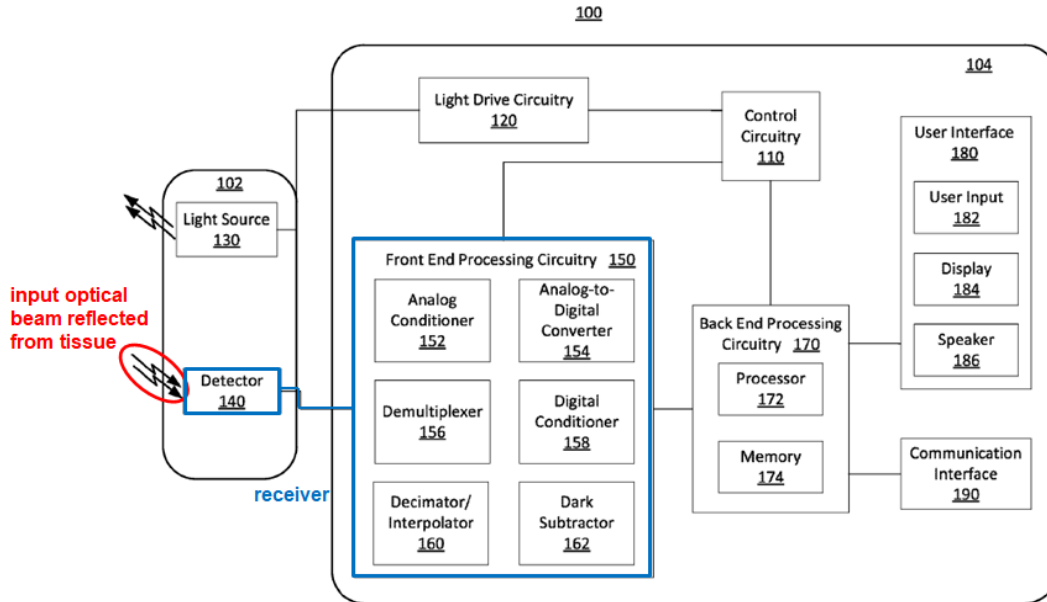

FIG. 1

Ex.1003, ¶125. Lisogurski thus describes “a receiver, wherein the receiver includes a plurality of spatially separated detectors.”

As noted above (§VI.A.4), Omni may argue that Lisogurski does not teach this element because the front end processing circuitry is depicted in monitor 104 which is separate from wearable sensor 102 that contains the detectors. To the extent it is found that the claims require the front end processing circuitry and detectors to be in the same device and that such configuration is not shown Lisogurski, the skilled person would have considered it to have been obvious based on Lisogurski's own teachings. Ex.1003, ¶¶126-27.

Lisogurski teaches an embodiment where the sensor is a separate, battery-powered device that is wirelessly connected to the monitor. Ex.1011, 17:55-59, 18:23-25; *see also id.*, 18:16-31, 17:32-35. It also explains that the sensor can “preprocess” the electrical signal before transmitting the signal to the monitor. Ex.1011, 11:20-27. While this wireless configuration is not depicted in Lisogurski's figures (as Lisogurski itself notes, Ex.1011, 17:55-59), the skilled person would have considered it obvious to configure the system to work that way based on the functional relationship between these elements. Ex.1003, ¶¶127-28.

As Dr. Anthony explains, the skilled person would have found it obvious to design the wireless sensor to include the front end processing circuitry so that the sensor could process the detected signal and wirelessly transmit it to the monitor. Ex.1003, ¶¶128-29. That person would have understood that the analog signal output from the detector would need to be converted to digital form for efficient

wireless transmission. *Id.* Thus, that person would have found it obvious to include the front end processing circuitry, which performs analog-to-digital conversion and other initial processing of the signal, in the sensor where the signal is captured. *Id.* The necessary circuitry is small and power efficient, and could easily be integrated into the wearable sensor without affecting the sensor's operation. *Id.* This is also consistent with the indication in Lisogurski that “[i]n some embodiments the functionality of some of the components may be combined in a single component... [or] the functionality of some of the components of monitor 104... may be divided over multiple components.” Ex.1011, 16:2-9; Ex.1003, ¶130.

Finally, a skilled person would have found a motivation to combine these elements into the sensor component based on general trends in the industry in 2012, which would encourage inclusion of additional features into wearable devices to improve their operation in mobile monitoring systems or for sports and personal fitness applications. Ex.1003, ¶131; *see* §III.B, above.

**(1) “the detectors configured to... capture light while the LEDs are off and convert the captured light into a first signal”**

Lisogurski teaches a “dark subtraction” technique for “removing ambient and background signals.” Ex.1011, 13:60, 6:7-10; Ex.1003, ¶132; *see generally*, Ex.1011, 6:7-19, 13:60-14:10, 16:33-54 (describing dark subtraction process).

Using this technique, the detectors measure the light when the LEDs are on and when the LEDs are off to remove “dark current” or ambient light from the signal. Ex.1011, 12:59-13:6 (“The peaks of detector current waveform 214 may be synchronous with light ‘on’ periods... The valleys... may be synchronous with periods of time during which no light is being emitted by the light source... [D]ark current 222 may be removed...”).

Lisogurski explains that “the system [may] turn[] on a first light source, followed by a ‘dark’ period, followed by a second light source, followed by a ‘dark’ period.” Ex.1011, 6:12-15. “The system may measure the ambient light detected by the detector during the ‘dark’ period and then subtract this ambient contribution from the signals received during the first and second ‘on’ periods.” Ex.1011, 6:16-19; Ex.1003, ¶133.

The detectors and front end processing circuitry measure a “dark signal” by “determining the amount of dark signal during [each] ‘off’ period 220”—in other words, it measures the light received by the detectors while the LEDs are off. Ex.1011, 13:67-14:6; Ex.1003, ¶134. To determine the dark signal, each detector “converts the intensity of the received light into an electrical signal.” Ex.1011, 11:14-16; *see* Ex.1011, 13:35-41. The dark signal 222 (also called dark current 222) is measured during dark period 220, and is depicted in Figures 2A and 2B, annotated below:

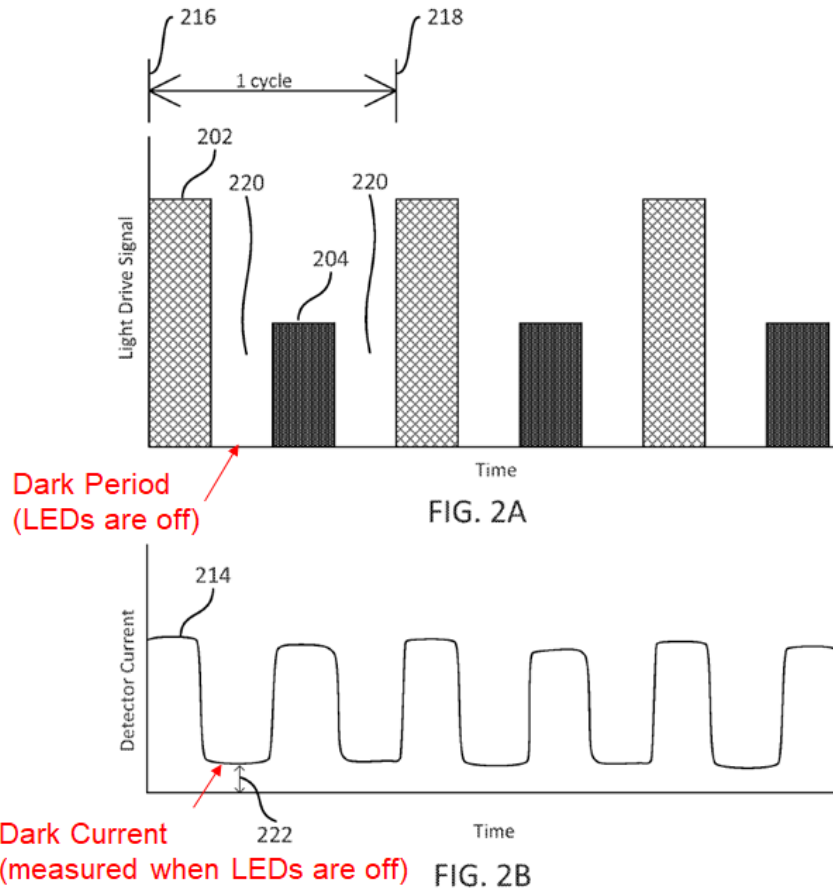

Ex.1003, ¶134; Ex.1011, Figs. 2A (current used to illuminate the LEDs) & 2B (the current output by the detector), 12:64-13:6; *see id.*, 13:67-14:6 (“in reference to FIG. 2A, a detection signal peak corresponding to red ‘on’ period 202 may be adjusted by determining the amount of dark signal during the ‘off’ period 220 preceding red ‘on’ period 202”). The front end processing circuitry uses the current measured when the LEDs are off to generate a “dark signal.” Ex.1011, 13:35-41 (“Demultiplexer 156 may operate on detector current waveform 214 of FIG. 2B to generate... a *first dark signal* (e.g., corresponding to the dark component that occurs immediately after the Red component), and a *second dark*

*signal* (e.g., corresponding to the dark component that occurs immediately after the IR component).”); Ex.1003, ¶135.

Therefore, Lisogurski teaches detectors configured to capture light during a dark period (“*while the LEDs are off*”) and to convert that to a dark signal (“*first signal*”). Ex.1003, ¶136.

**(2) “the detectors configured to... capture light while at least one of the LEDs is on and convert the captured light into a second signal, the captured light including at least a portion of the input optical beam reflected from the tissue”**

In the dark signal subtraction process, Lisogurski’s detectors and front end processing circuitry also measure the signal while at least one LED is on such that they capture a portion of the optical beam reflected from tissue. Ex.1003, ¶137.

As explained above with respect to the previous element, “the system [may] turn[] on a first light source, followed by a ‘dark’ period, followed by a second light source, followed by a ‘dark’ period.” Ex.1011, 6:12-15. “The system may measure the ambient light detected by the detector during the ‘dark’ period and then subtract this ambient contribution from *the signals received during the first and second ‘on’ periods.*” Ex.1011, 6:16-19; *see* Ex.1003, ¶138.

The system will measure a red signal, Ex.1011, 13:67-14:2 (“a detection signal peak corresponding to red ‘on’ period 202”) and an IR signal, Ex.1011, 16:52-53 (“the levels received during... IR ‘on’ period 278.”). *See* Ex.1011,

11:14-16 (each detector “convert[s] the intensity of the received light into an electrical signal”), 13:35-41 (“Demultiplexer 156 may operate on detector current waveform 214 of FIG. 2B to generate *a Red signal* [and] *an IR signal...*”);

Ex.1003, ¶139. This is depicted in Figures 2A and 2B, annotated below:

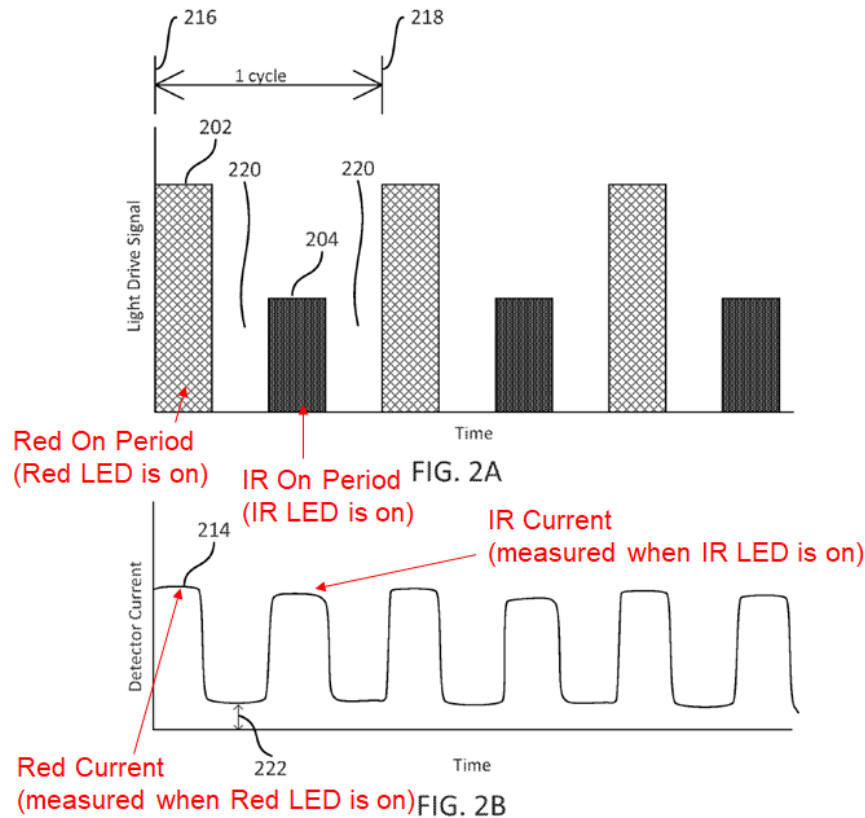

Ex.1003, ¶139; Ex.1011, Figs. 2A & 2B, 12:52-13:6.

The light received by the detectors includes “the light that is reflected by or has traveled through the subject’s tissue.” Ex.1011, 17:40-42; 11:12-20 (“[L]ight may enter detector 140 after passing through the subject's tissue. Detector 140 may convert the intensity of the received light into an electrical signal. *The light intensity may be directly related to the absorbance and/or reflectance of light in*

*the tissue.*”). This includes the IR light (“*input optical beam reflected from the tissue*”) emitted by the LEDs. Ex.1011, 17:8-10 (“the levels received during... IR ‘on’ period 278.”), 13:35-41.

Therefore, Lisogurski describes detectors configured to capturing light when one of the IR LEDs is on (“*while at least one of the LEDs is on*”) and converting that to an electrical signal (“*second signal*”). Ex.1003, ¶139.

- e) **wherein at least one analog to digital converter is coupled to the spatially separated detectors and is configured to generate at least a first data signal from the first signal and at least a second data signal from the second signal**

Lisogurski’s system includes an analog-to-digital converter. Ex.1011, 13:21-27, 13:27-30 (“Analog-to-signal converter 154 may be any suitable type of analog-to-digital converter...”). As shown in annotated Figure 1 below, the analog-to-digital converter is part of the front end processing circuitry that is connected to the detectors. As explained above, the detectors and front end processing circuitry together are the “*receiver*”. The detectors generate electrical signals that are received by the front end processing circuitry, and those signals are passed between the components of the circuitry. Ex.1011, 13:6-60.

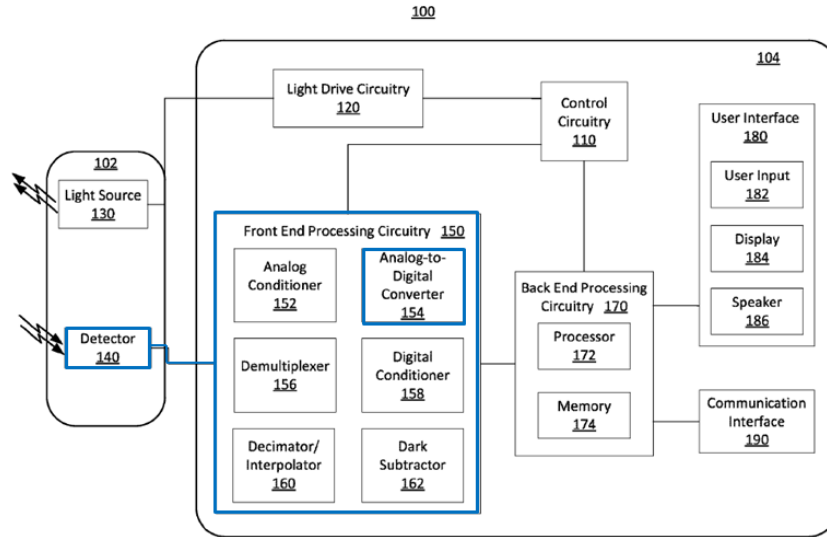

FIG. 1

Ex.1003, ¶140; Ex.1011, Fig. 1, 13:7-12.

Lisogurski explains that “Dark subtractor 162 may operate on the digital signal.” Ex.1011, 13:60; *see* Ex.1011, 11:43-46, 33:65-34:13; *id.*, 13:35-41 (“Demultiplexer 156 may operate on detector current waveform 214 of FIG. 2B to generate *a Red signal* [and] *an IR signal...*”). A skilled person would understand that this means the analog-to-digital converter converts the dark signal (“*first signal*”) and the IR signals (“*second signal*”) into digital form (a “*first data signal*” and a “*second data signal,*” respectively). Ex.1003, ¶141.

- f) **the measurement device configured to improve a signal-to-noise ratio of the input optical beam reflected from the tissue by differencing the first data signal and the second data signal to generate an output signal representing at least in part a non-**

**invasive measurement on blood contained within the tissue**

Lisogurski discloses that “[d]ark subtractor 162 may operate on the digital signal.” Ex.1011, 13:60; *see* Ex.1011, 11:43-46, 33:65-34:13; *id.*, 13:35-41. A POSA would understand that this means the analog-to-digital converter converts the dark signal (“*first signal*”) and the IR signals “*second signal*”) into digital form (a “*first data signal*” and a “*second data signal*,” respectively) before the dark subtractor operates on the signals. Ex.1003, ¶142. Lisogurski describes the ambient light in the signal as noise. Ex.1011, 14:46-55 (discussing “ambient light noise” in the analog signals).

Lisogurski explains that the dark signal subtractor subtracts the digital dark signal from the digital IR signals to generate an “adjusted... IR signal[]” (“*output signal*”):

[D]ark subtractor 162 *may subtract dark values from the Red and IR components to generate adjusted Red and IR signals*. For example, dark subtractor 162 *may determine a subtraction amount from the dark signal* portion of the detection signal and subtract it from the peak portion of the detection signal in order to reduce the effect of the dark signal on the peak.... *The dark signal amount determined in this manner may be subtracted from the detector peak corresponding to red “on” period 202.*

Ex.1011, 13:60-14:10; *see* Ex.1011, 16:51-54 (“The system may subtract the background or dark level from the levels received during red ‘on’ portion 274 and

IR ‘on’ period 278.”). Thus, Lisogurski teaches subtracting (“*differencing*”) the dark signal (“*first data signal*”) from the IR signal (“*second data signal*”); Ex.1003, ¶143.

Because the dark signal subtraction process removes noise (ambient light) from the IR signal (“*second data signal*”), a POSA would have understood that it increases the signal-to-noise ratio. Ex.1003, ¶144. The signal-to-noise ratio is calculated by dividing the signal power by the noise power:  $\frac{S}{N}$ . Ex.1003, ¶144. Decreasing the noise necessarily increases the signal-to-noise ratio. *Id.*

The adjusted IR signal (“*output signal*”) represents “*a non-invasive measurement on blood contained in the tissue.*” Lisogurski uses these signals to “determine one or more physiological parameters.” Ex.1011, 14:60-64; *see id.*, 1:22-25, 1:48-52. For example, Lisogurski may use the adjusted IR signals to determine “blood constituent concentration,” such as blood oxygen saturation of hemoglobin, as well as physiological parameters such as heart rate, blood pressure, and other parameters. Ex.1011, 4:36-59, 8:4-8, 11:20-25. A determination of “blood constituent concentration” such as the blood oxygen saturation of hemoglobin is “*a non-invasive measurement on blood contained in the tissue.*” Ex.1003, ¶145.

- g) wherein the modulating at least one of the LEDs has a modulation frequency, and wherein the receiver is**

**configured to use a lock-in technique that detects the modulation frequency**

Lisogurski teaches that the front end processing circuitry is synchronized with the light drive circuitry that controls LED modulation. Ex.1011, 11:41-46 (“front end processing circuitry 150 may... operate *synchronously* with light drive circuitry 120. For example, front end processing circuitry 150 may *synchronize* the operation of an analog-to-digital converter and a demultiplexer with the light drive signal based on the timing control signals.”). Thus, the front end processing circuitry and the detector (“*receiver*”) are synchronized to the light drive signal. Ex.1003, ¶146.

Lisogurski describes providing the same timing signals to the light drive circuitry that controls the LEDs and the front end processing circuitry that controls the detectors to synchronize their operation, but Lisogurski does not explicitly describe the type of synchronization technique that it uses. Ex.1003, ¶147. Synchronization techniques were well-known in the art, and a POSA would have found it obvious to look to other references for details on how to select or implement that technique. *Id.*

It was well-known that a lock-in technique is one way of synchronizing a detector with a light source, and that this technique had the benefit of improving the signal-to-noise ratio. Ex.1003, ¶¶147-48; Ex.1019, 766 (“synchronized lock-in amplifier detection” allows for “improved selectivity and enhanced signal-to-noise

ratio”). Carlson teaches a technique for using lock-in amplification to synchronize a detector with a light source by using. Ex.1009, [0020]. Carlson explains that lock-in techniques are well-known in the art. Ex.1009, [0065].

Carlson describes its lock-in technique, explaining that the LED light source is modulated at a particular frequency, and the detector implements band pass filters to remove signals outside of a narrow band (*e.g.*, +/- 5 Hz) around the modulation frequency (“ $f_0$ ” in Carlson). Ex.1009, [0020], [0069] (as shown in “FIG. 9, it is possible to arrange a filter band pass... shown in form of the dashed line 51. As a result, we end up... only showing any measurements in the range of  $f_0-5$  Hz to  $f_0+5$  Hz.”), Fig. 9; *see* Ex.1003, ¶148. This process increases signal-to-noise ratio and removes noise from the signal. As Carlson explains:

The basic idea of using AC-Coupling or Lock-In Amplification (synchronous detection), is to temporarily modulate the amplitude of the optical radiation of, *e.g.*, the LED at a carrier frequency  $f_c$  in order to shift the power spectrum of the pulsoximeter signals into a higher frequency range where environmental optical radiation is unlikely and electronic band pass filtering is technologically less stringent. Thus, the pulsoximeter signals are readily discriminated from electronic and parasitic contributions of environmental optical radiation outside the frequency range of, *e.g.*  $f_c \pm 5$  Hz, increasing significantly the S/N (Signal/Noise)- and S/B ratio.

Ex.1009, at [0020]; *see id.*, [0027], [0065]; Ex.1003, ¶148.

The skilled person would have had reason to implement Lisogurski's synchronization functionality using a lock-in technique as described by Carlson. Ex.1003, ¶150. Lisogurski teaches the benefits of removing noise from the signal, Ex.1011, 6:7-29, 14:50-55, and lock-in detection was a known way of doing so, Ex.1019, 766 (lock-in detection allows "improved selectivity and enhanced signal-to-noise ratio"). Ex.1003, ¶150. The skilled person would have recognized that lock-in techniques are commonly used with optical sensors, (Ex.1019, 766), and that incorporating that technique into Lisogurski's sensor was a predictable arrangement of known elements, with each performing the same function it was known to perform and yielding what one would expect from the arrangement. Ex.1003, ¶151.

The Lisogurski front end processing circuitry is provided with the timing signals that are used to control the modulation of the LEDs, and consequently, can detect the frequency and phase of the LED pulses. Ex.1003, ¶152. The skilled person would have found it obvious to use lock-in detection on the signal picked up by the photodetectors to isolate the modulation frequency. Ex.1003, ¶153.

Carlson's lock-in technique—which uses bandpass filtering to remove noise from frequencies outside of the modulation frequency—is consistent with how that

technique is described in the '698 specification.<sup>8</sup> Ex.1001, 13:36-44 (“the techniques from lock-in detection may be used, where narrow band filtering around the modulation frequency may be used to reject noise outside the modulation frequency”), 21:51-55 (“Using a lock-in type technique (e.g., detecting at the same frequency as the pulsed light source and also possibly phase locked to the same signal), the detection system may be able to reject background or spurious signals and increase the signal-to-noise ratio of the measurement.”). Thus, Lisogurski and Carlson render this element obvious.

## 6. Claim 2

Claim 2 depends from claim 1 and specifies “*wherein the plurality of LEDs and the plurality of spatially separated detectors are mounted on a common structure, and wherein the plurality of LEDs are coupled electrically to a power supply.*”

---

<sup>8</sup> While the parties originally proposed different claim constructions for “lock-in,” they agreed before the Markman hearing to the district court’s preliminary claim construction, which states: “plain and ordinary meaning. The ‘lock-in technique’ is not any technique that ‘lessens noise outside the modulation frequency.’” Ex.1043, 6. This petition uses the plain and ordinary meaning, as agreed to by the parties.

As explained in §VI.A.5.b)(2) and §VI.A.5.e), Lisogurski’s sensor includes a plurality of LEDs and a plurality of spatially separated detectors. Ex.1011, 17:43-45 (“sensor unit 312 may include multiple light sources and detectors, which may be spaced apart”).

Lisogurski explains that the LEDs and detectors are part of a single sensor, and depicts a sensor as a structure that includes both.

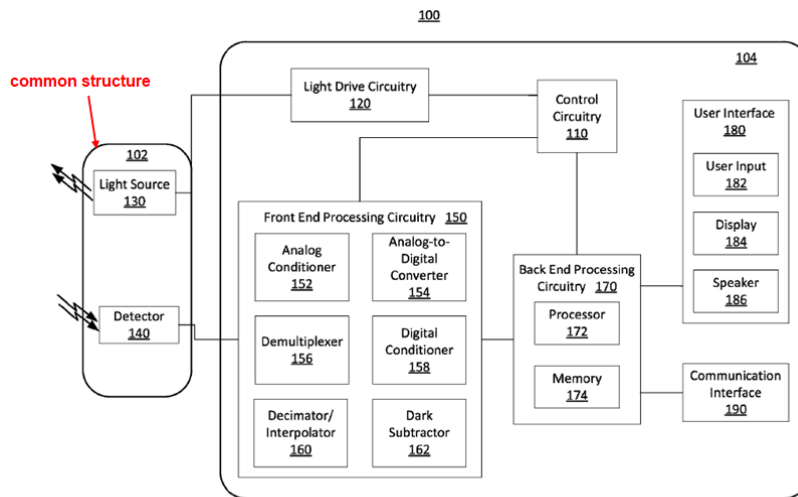

FIG. 1

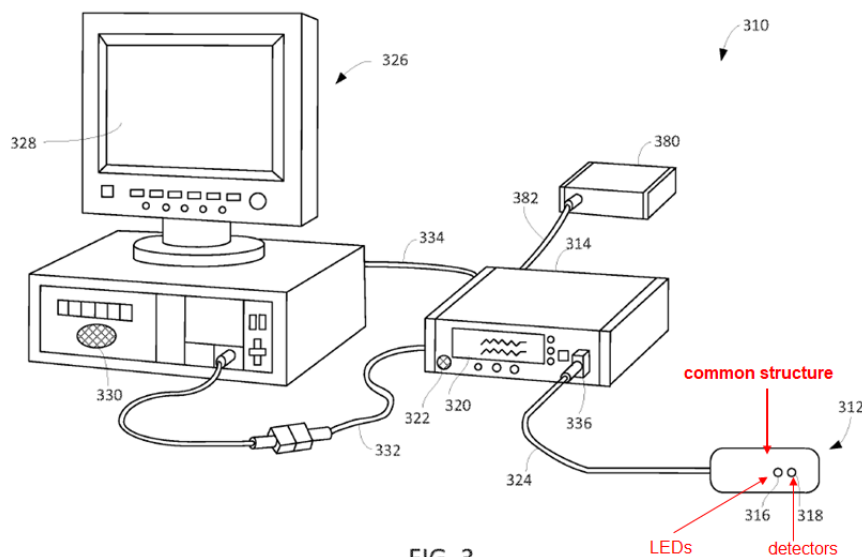

FIG. 3

A POSA would have understood that the LEDs and detectors were mounted on the sensor itself, and thus, they are mounted on a common structure. Ex.1003, ¶154.

Lisogurski teaches that its sensor is wireless and powered by an internal battery. Ex.1011, 17:55-56 (“Sensor unit 312 may be powered by... a battery”). A POSA would have understood that each of the LEDs are powered by the sensor’s battery, and therefore, each is electrically coupled to it (“*the plurality of LEDs are coupled electrically to a power supply*”). Ex.1003, ¶155.

### 7. Claim 3

Claim 3 depends from claim 1 and specifies “*wherein the light source is configured to further improve the signal-to-noise ratio of the input beam reflected from the tissue by increasing the light intensity relative to the initial light intensity from at least one of the LEDs, and wherein the receiver is configured to be synchronized to at least one of the LEDs.*”

a) **“the light source is configured to further improve the signal-to-noise ratio...”**

Lisogurski teaches that the light source is in the wearable sensor 102. Ex.1011, 10:48-49. It teaches alteration of the light drive parameters of the LEDs in response to “the level of noise, ambient light, [or] other suitable reasons,” and that “increas[ing] the brightness of the light sources in response to [increased level of background] noise to improve the signal-to-noise ratio.” Ex.1011, 9:46-52; *id.*,

5:55-6:6 (discussing modulation techniques and “conventional servo algorithms” for adjusting the light emitted by the LEDs), 1:67-2:3. It also explains that changes to the light drive parameters can be used to mitigate the effects of noise, motion, or ambient light, for example, to thereby increase the signal-to-noise ratio. Ex.1011, 5:59; 9:46-52, 9:57-60, 14:49-55; Ex.1003, ¶¶157-58.

Lisogurski also explains that signal modulation techniques are controlled by control circuitry and light drive circuitry, which generate a light drive signal for activating and controlling the sensor’s light sources. Ex.1011, 1:44-46, 11:38-41, 11:50-54. It identifies the light drive signal “[p]arameters that may be varied include light intensity, firing rate, duty cycle, other suitable parameters, or any combination thereof.” Ex.1011, 1:19-21. These light drive parameters correspond to brightness (light intensity), frequency (firing rate), and pulse width which is the duration of each pulse of light (duty cycle). Ex.1003, ¶159.

Lisogurski thus teaches that “*the light source [is] configured to increase signal-to-noise ratio*” by varying light drive parameters.

This circuitry is depicted in Figure 1 (annotations added) of Lisogurski:

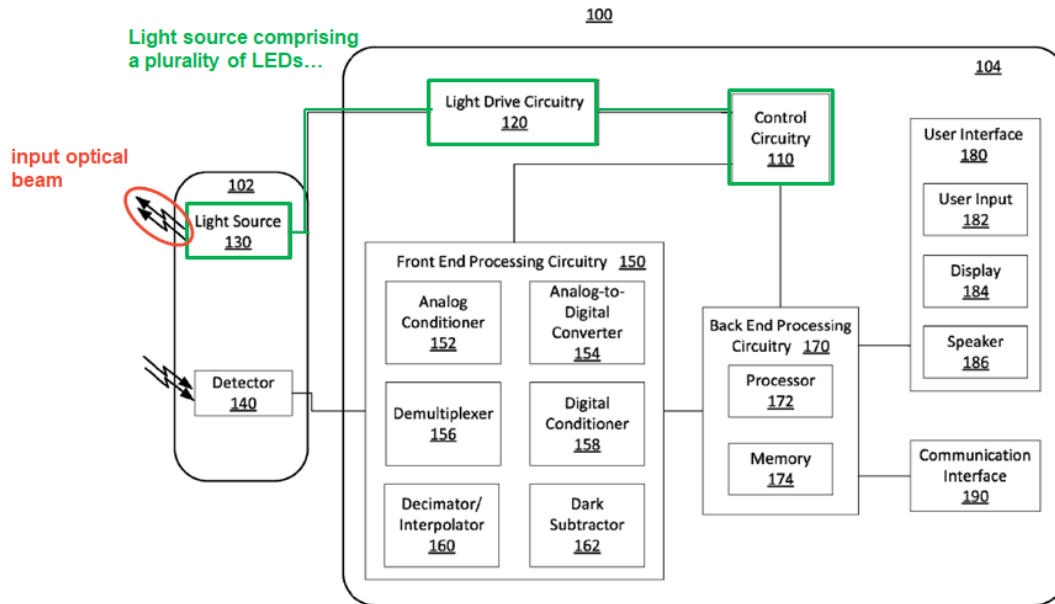

FIG. 1

Ex.1003, ¶166. As noted above (§VI.A.4), Patent Owner may contend that Lisogurski does not teach this element because the control and light drive circuitry that control the LEDs is depicted in monitor 104, which is separate from the wearable sensor 102 that contains the LEDs. To the extent the claims could be considered to require the control and light drive circuitry and the LEDs to be in the same device, that configuration of Lisogurski would have been obvious. Ex.1003, ¶¶167-68.

Lisogurski teaches a wireless embodiment, where the sensor containing the LEDs and detectors can be battery-powered and can wirelessly communicate with the monitor. Ex.1011, 17:55-59. Lisogurski teaches the control circuitry directs the light drive circuitry to generate the light drive signal, which is the electric current provided to the LEDs that turns them on and determines their brightness.

Ex.1011, 11:38-41, 11:50-54, 25:52-55; Ex.1003, ¶169. Because these circuits work together to output the electric current that is applied to the LEDs, the skilled person would have understood that this circuitry would need to be in the same device as the LEDs (the sensor), or at least that it was obvious to include the circuitry there. Ex.1003, ¶169; Ex.1011, 11:38-41, 11:50-54, 25:52-55.

Lisogurski teaches both a wired embodiment and a wireless embodiment, where the sensor containing the LEDs is battery-powered and separate from the monitor. Ex.1011, 17:55-59, 18:23-25; *see also id.*, 18:16-31, 17:32-35. The skilled person would have understood that in the wireless embodiment (which Lisogurski notes is not depicted in figures, Ex.1011, 17:55-59), the light drive and control circuitry would be in the wireless sensor so they could apply current to the LEDs. Ex.1003, ¶¶168-69. Lisogurski also expressly teaches dividing or combining discrete elements into one component, stating: “[i]n some embodiments the functionality of some of the components may be combined in a single component... [or] the functionality of some of the components of monitor 104... may be divided over multiple components.” Ex.1011, 16:2-9. The skilled person would have recognized this guidance to apply to configuration of the LEDs and the light drive and control circuitry, as those elements work together. Ex.1003, ¶¶169-70.

A skilled person also would have recognized that adding this additional circuitry to the sensor would not have negatively affected the operation of the device. Ex.1003, ¶170. Moreover, the necessary circuitry is small and power efficient, and could easily be integrated into the wearable sensor. *Id.* The skilled person would have had a motivation to do so from general trends in the industry in 2012, including those favoring integration of multiple features and capabilities in wearable devices to improve their operation in mobile monitoring systems or for sports and personal fitness applications. Ex.1003, ¶171; *see* §III.B, above.

Consequently, an ordinary artisan would have found it obvious to modify the illustrated implementation of Lisogurski in Figure 1 to combine the light drive and control circuitry into a wireless sensor containing the LEDs. Ex.1003, ¶¶167-71.

**b) “...by increasing the light intensity relative to the initial light intensity from at least one of the LEDs”**

Lisogurski teaches increasing the signal-to-noise ratio by increasing the “brightness” of a light source, which is the light intensity of that light source (“*increasing a light intensity*”). Ex.1003, ¶¶163-65. For example, Lisogurski explains that the sensor may receive “an increased level of background noise in the signal due to patient motion. The system may *increase the brightness of the light sources* in response to the noise *to improve the signal-to-noise ratio.*” Ex.1011, 9:46-52; *see id.*, 37:6-22, 6:3-6 (describing increasing SNR by increasing brightness).

c) **“wherein the receiver is configured to be synchronized to at least one of the LEDs”**

As explained in §VI.A.5.d) above, the detectors and front end processing circuitry together are “*a receiver.*” Ex.1011, 12:42-44; Fig. 1.

Lisogurski explains that the front end processing circuitry is synchronized with the light drive circuitry that controls the modulation of the LEDs. Ex.1011, 11:41-46 (“front end processing circuitry 150 may... operate *synchronously* with light drive circuitry 120. For example, front end processing circuitry 150 may *synchronize* the operation of an analog-to-digital converter and a demultiplexer with the light drive signal based on the timing control signals.”).

As explained in §VI.A.5.g) above, the skilled person would have found it obvious to implement Lisogurki’s synchronization process using Carlson’s lock-in technique. Carlson explains that its lock-in technique provides for “synchronous detection” by modulating the LED at a particular frequency and then using filters on the detection side to filter other frequencies out of the signal. Ex.1009, [0065], [0020]; *see* Ex.1003, ¶173.

Thus, the front end processing circuitry and the detector (“*receiver*”) are “*synchronized*” to the light drive signal (“*at least one of the LEDs*”). Ex.1003, ¶¶172-73.

Lisogurski describes another way that the front end processing circuitry and the detector (“*receiver*”) are “*synchronized*” to the light drive signal (“*at least one*

*of the LEDs*”). Ex.1003, ¶172. Lisogurksi describes embodiments where the firing rate of an LED is correlated to the sampling rate of an analog-to-digital converter in the detector. Ex.1011, 33:47-49 (“In some embodiments, sampling rate modulation may be correlated with light drive signal modulation.”); *see also* 2:1-2, 27:44-52 (LED firing rate can be modulated), 35:27-31 (“increasing the emitter firing rate... correlates to an increased sampling rate”). Lisogurski teaches an embodiment where the measurements taken by the receiver have a one-to-one correlation, with one sample taken per on period. Ex.1011, 35:17-19.<sup>9</sup> A POSA would have understood that in this embodiment, the LEDs and the receiver are synchronized. Ex.1003, ¶174.

## 8. Claim 5

Claim 5 depends from claim 1 and specifies “*wherein the wearable device is configured to communicate with a smart phone or tablet, the smart phone or tablet comprising a wireless receiver, a wireless transmitter, a display, a voice input module, a speaker, and a touch screen, the smart phone or tablet configured to receive and to process at least a portion of the output signal, wherein the smart*

---

<sup>9</sup> Lisogurski discloses different embodiments where there is not a one-to-one correlation, and instead multiple samples are taken per on period and then averaged. Ex.1011, 35:19-23.

*phone or tablet is configured to store and display the processed output signal, wherein at least a portion of the processed output signal is configured to be transmitted over a wireless transmission link.”*

Lisogurski describes a monitor that includes back end processing circuitry, a user interface, and a display that allows a user to see the monitored person’s physiological parameters and to configure the operation of the system. Ex.1011, 15:19-42; Ex.1003, ¶176.

A POSA reading Lisogurski’s disclosure that the monitor can be a portable, battery powered computing system that includes a touchscreen, Ex.1011, 1:16-18 (portable), 15:20-23 (touch screen), 18:65-66 (battery powered), would have recognized that there were a finite number of options for what that device could be. That person would have immediately envisioned that that both a tablet computer and a smartphone were such devices. Ex.1003, ¶177; *see Kennametal, Inc. v. Ingersoll Cutting Tool Co.*, 780 F. 3d 1376, 1381 (Fed. Cir. 2015) (a reference can anticipate a claim even if it “d[oes] not expressly spell out” all the limitations arranged or combined as in the claim, if a person of skill in the art, reading the reference, would “at once envisage” the claimed arrangement or combination); *see In re Petering*, 301 F.2d 676 (CCPA 1962). Other possible devices are a laptop or a custom made device. Ex.1003, ¶177. As explained in §IV.B, above, it was well-known by 2012 that tablets and smartphones could be used in mobile sensor

systems, and there was a general trend in the industry to develop such devices.

Ex.1003, ¶¶48-56. Thus, a POSA would have considered it obvious to implement Lisogurski's monitor as a tablet or smart phone. Ex.1003, ¶177.

Lisogurski describes the monitor as including the additional elements of the claim. Ex.1003, ¶178. The back end processing circuitry is coupled to the user interface, which may include “any type of user input device such as a keyboard, a mouse, *a touch screen, buttons*, switches, *a microphone*, a joy stick, a touch pad, or any other suitable input device.” Ex.1011, 15:20-23 (emphases added); Fig. 1. The user interface also includes a *display* and a *speaker*. Ex.1011, 15:19-20; Fig 1. The back end processing circuitry is connected to a communication interface that “may include one or more *receivers* [or] *transmitters*” each of which “may be configured to allow ...*wireless* communication.” Ex.1011, 15:49-56 (emphases added).

Thus, Lisogurski's monitor includes “*a wireless receiver, a wireless transmitter, a display, a voice input module, a speaker, and a touch screen.*”

The back end processing circuitry in the monitor includes a processor that receives and processes the output signal from the front end processing circuitry (“*configured to receive and process at least a portion of the output signal*”).

Ex.1011, 14:60-64. “For example, processor 172 may determine one or more

physiological parameters based on the received physiological signals.” Ex.1011, 14:62-64; Ex.1003, ¶179.

Lisogurski explains that the monitor displays the calculated physiological parameters (“*processed output signal*”), Ex.1011, 17:59-18:5, and can store a history of those parameters, Ex.1011, 15:5-16, 27:31-36, 33:23-27. Thus, the monitor “*store[s] and display[s] the processed output signal.*” Ex.1003, ¶¶179-80.

The calculated physiological parameters also can be wirelessly transmitted to other devices, Ex.1011, 15:43-48, 15:53-57, 18:49-53, 18:58-65, including a server or website, Ex.1011, 20:55-60, 26:55-60, and another monitor, Ex.1011, 18:58-65. Thus, Lisogurski shows that “*at least a portion of the processed output signal is configured to be transmitted over a wireless transmission link.*” Ex.1003, ¶¶181-82.

## **B. Lisogurski, Carlson, and Hanna Render Obvious Claims 1-3, 5**

### **1. Overview of Hanna**

Hanna is a patent that issued on January 7, 2003. It is prior art under 35 U.S. § 102(a) (AIA) and 35 U.S. § 102(a) and (b) (pre-AIA). Hanna describes a pulse oximeter, shown below, that can be worn on a user’s ear or finger to measure oxygen saturation or other constituents of the user’s blood:

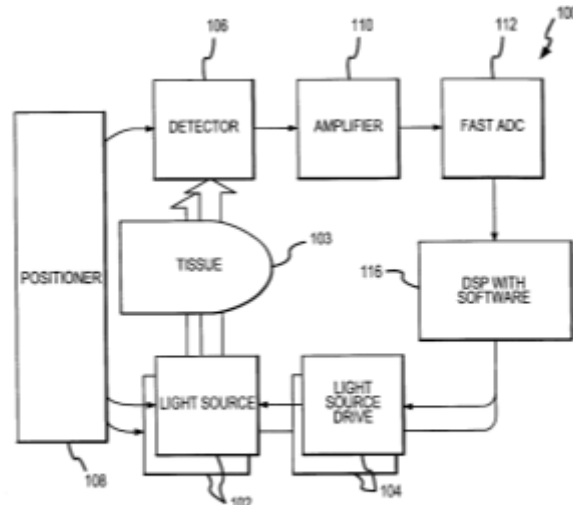

FIG. 1

Ex.1007, Fig. 1, 1:25-39. The sensor has multiple emitters 102, which can be a red LED and an infrared LED. Ex.1007, 4:34-43. The signals from these light sources “are modulated using different code sequences.” Ex.1007, 4:43-51, Fig. 2-4, 6:13-8:25 (describing encoded signals). The modulated light is applied to the user’s tissue 103, and the transmitted or reflected light is detected by one or more detectors 106. *Id.*, 4:67-5:18, 8:26-33, 1:48-49. The purpose of encoding the light is to “allow the contribution of each source to the detector output to be determined.” Ex.1007, 1:49-51, 2:23-29. Modulating the signals using the codes creates signals that are non-periodic, which also allows the detector to discriminate between noise sources that are periodic in nature and the modulated signal, because the modulated light generated by each emitter includes a unique code that is not found in noise. Ex.1007, 2:29-31, 2:59-62, 4:51-54.

As Hanna describes, each code is identifying information that is included in a modulated emitter signal. Ex.1007, 6:13-8:25; Ex.1003, ¶¶183-84. Thus, Hanna teaches modulating light to include information, as required by the district court's preliminary claim construction. Ex.1003, ¶¶183-84.

## **2. A Skilled Person Would Have Combined Lisogurski and Carlson With Hanna**

A skilled person would have found it obvious to include Hanna's coding technique in the Lisogurski device to increase the detectability of the signals of interest in the presence of noise. Ex.1003, ¶¶185-86. Lisogurski teaches use of multiple LEDs, Ex.1011, 19:25-31, and that multiple modulation techniques can be used, Ex.1011, 7:38-40, and including Hanna's technique would have allowed the detector to efficiently determine the signal contribution from each LED. Ex.1003, ¶188.

A skilled person following his or her ordinary design processes would consider and evaluate known techniques and structures used in analogous systems such as Hanna that could improve performance. Ex.1003, ¶189. Improving performance by making signals of interest more detectable in the presence of noise is a specific objective of Hanna's coding technique. Ex.1007, 2:3-31. Hanna explains that use of its non-periodic codes provides a specific benefit when in the presence of periodic noise sources as compared to time division multiplexed signals (as used in Lisogurski). Ex.1007, 2:59-62, 4:51-54; Ex.1003, ¶189. Like

Hanna, Lisogurski recognizes the desirability of removing noise from a signal of interest. Ex.1011, 6:7-19, 14:50-55. A skilled person would have turned to the coding technique described by Hanna as a known way of accomplishing this objective. Ex.1003, ¶¶189-90. Thus, a skilled person would have been motivated to include the Hanna technique in the Lisogurski device in order to obtain the performance benefits described by Hanna. Ex.1003, ¶¶190-91.

The skilled person also would have recognized that incorporating Hanna's coding technique into the Lisogurski sensor would involve combining familiar elements according to known methods, yielding predictable results. Ex.1003, ¶192. Both Lisogurski and Hanna describe optical sensors that use multiple emitters, which were common and well-known components of these types of devices. Ex.1003, ¶193; Ex.1019, 765. Modulating light to convey information was also a well-known technique, both in the context of optical sensors and in many other contexts.<sup>10</sup> Ex.1003, ¶194. Lisogurski teaches using modulation, and a skilled person would have been able to reasonably predict that incorporating Hanna's known modulating technique into the Lisogurski device would be to make

---

<sup>10</sup> The '698 specification provides no explanation of how or why a signal would be modulated to include information (*see* Ex.1001, 9:32-34), presumably because this was well known at the time.

it easier to distinguish signals of interest from noise and to thereby improve performance. Ex.1003, ¶¶192-93.

Hanna, Lisogurski, and Carlson also describe analogous optical sensors. Like Lisogurski and Carlson, Hanna describes use of its techniques in devices used in the medical or health care fields. Ex.1007, 1:24-26. Hanna also describes devices that can be worn, for example, on an earlobe or finger. Ex.1007, 1:39. Lisogurski, Carlson, and Hanna, all in the field of optical sensing technology, thus describe analogous systems with common applications and utility, and all describe techniques for improving the performance of measurement devices that include an optical sensor by removing noise. Ex.1003, ¶¶193, 195. The skilled person would have considered the references together when implementing a system based on the teachings of Lisogurski. Ex.1003, ¶195.

### **3. Lisogurski, Carlson, and Hanna Render Obvious Claims 1-3 and 5**

As explained above, Lisogurski and Carlson render all the elements of Claims 1-3 and 5 obvious. To the extent Lisogurski and Carlson do not teach modulating an LED to create a beam that contains information, configuring Lisogurski to do so would have been obvious based on Hanna, as described above. Ex.1003, ¶196.

Thus, claims 1-3 and 5 would have been obvious based on Lisogurski and Carlson in combination with Hanna.

**C. Lisogurski, Carlson, and Rulkov, with or without Hanna, Render Obvious Claim 5**

**1. Overview of Rulkov**

Rulkov is a U.S. Patent filed on October 4, 2011, and issued on May 8, 2012. It is prior art under 35 U.S.C. § 102(a) and § 102(d) (AIA) or § 102(e) (pre-AIA).

Rulkov describes a monitoring device that includes an optical sensor and is worn on a subject's wrist. Ex.1014, 4:41-44, 5:4-9, Figs. 1, 26, 27. The monitoring device can include a pulse oximeter that measure the user's heart rate and oxygen saturation. Ex.1014, 1:51-52, 6:56-60. The monitoring device can communicate with a smartphone such as an iPhone. Ex.1014, 1:42-45, 5:48-52, 13:43-54. Rulkov shows that the smartphone can process, store, and display the data collected by the monitoring device. Ex.1014, 6:43-45, 14:21-25, 17:6-26, Figs. 25, 26, 28.

**2. A Skilled Person Would Have Modified Lisogurski and Carlson to Incorporate Elements Shown in Rulkov**

A skilled person would have considered making modifications to the systems described in Lisogurski and Carlson based on the teaching in Rulkov.

Lisogurski describes a PPG system that is designed to optimize power consumption and improve the portability of measurement systems. Ex.1011, 1:4-6, 1:16-18, 3:50-53, 4:63-67. Lisogurski describes these improvements in a system that includes a wearable sensor, *e.g.*, one worn on a wrist, that wirelessly

communicates with a monitoring device. Ex.1011, 4:15-20, 17:51-58. Carlson also teaches techniques for improving the operation of wearable sensor systems, such as those used in hospitals, mobile monitoring, and by athletes. Ex.1009, [0002], [0004], [0048].

A person of ordinary skill reading Lisogurski and Carlson would have looked to other references that disclosed techniques for improving the operation of portable optical sensing systems, particularly those with wearable sensors. Ex.1003, ¶201. It was part of the ordinary design process to look for ways to improve the operation of a device by looking to complementary designs and techniques. Ex.1003, ¶201.

The skilled person would have looked to Rulkov, which is a reference that describes techniques for improving the functionality of a wearable optical sensor for sports applications. Ex.1014, 15:30-32, Figs. 26-28.

Lisogurski, Carlson, and Rulkov are analogous references, each describing techniques for improving the operation of portable and wearable optical sensing devices. Ex.1003, ¶¶201-03; Ex.1014, 2:44-46, 2:57-62, 14:21-35. The skilled person would have considered the references together when implementing a system based on Lisogurski's teachings. Ex.1003, ¶203.

As explained in §IV.B, above, by 2012, there was a general trend in the industry to create wearable devices, to allow the device to be used in mobile

monitoring systems or to allow the device to be used for sports and personal fitness applications. Ex.1003, ¶204. Thus, the skilled person would have had reason to look to analogous references to create wearable devices that performed better in mobile and consumer applications. *Id.* The skilled person would have been motivated to include features from Rulkov in Lisogurski's system. Ex.1003, ¶205. These features, and more specific reasons for combining them, are described in the analyses below.

### 3. Claim 5

Claim 5 depends from claim 1 and specifies “*wherein the wearable device is configured to communicate with a smart phone or tablet...*”

As explained above, Lisogurski teaches a monitor that is a portable, battery powered computing system that includes a touchscreen. Ex.1011, 15:20-23, 18:65-66. As explained in §VI.A.8 above, the monitor teaches or at least renders obvious all of the elements of claim 5.

Patent Owner may contend that Lisogurski does not teach a smartphone or tablet. Even if that argument were accepted, Lisogurski and Carlson in view of Rulkov also render that element obvious. Ex.1003, ¶¶207-08.

A POSA reading Lisogurski would understand that the back end processing, user interface, and communications interface functionality of the monitor were just standard features of conventional computing systems—processing data, providing

a user interface using a display and other standard components, and providing for communications among computing devices. Ex.1003, ¶208. Choosing to implement the monitor using a smartphone would have been a logical design choice given that industry trends were pushing development to sensors that communicate with mobile devices. Ex.1003, ¶¶208-09, 211. Such a design would have had known benefits, including improved mobility and portability. Ex.1003, ¶¶208, 211. Designing the sensor to work with a smartphone, which were widely used, would have allowed for quick development of the sensor, leveraging existing technology. *Id.*

Lisogurski explains the monitor is used calculate, display, and store physiologic parameters. Ex.1011, 17:59-18:5. The skilled person would have understood that these functions of the monitor could be implemented on a smartphone as taught by Rulkov. Ex.1003, ¶¶209-10, 212-13. Rulkov shows that a smartphone such as an iPhone runs an app that collects data from the wearable monitoring device, processes it, and displays it to a user. Ex.1014, Figs. 26-28. For example, Rulkov shows the smart phone can process the sensor data to calculate heart rate, display current heart rate and heart rate history, and store information. Ex.1014, Figs. 26-28, 14:15-25, 15:6-13. A smartphone such as an iPhone includes the input, display, and communications elements included in Lisogurski's monitor. Ex.1011, 15:19-20 (display and a speaker), 15:20-23 (input

devices such as a touchscreen, a microphone, and buttons), 15:49-56 (wireless receivers and transmitters); Fig. 1; *see* Ex.1003, ¶¶209-10, 212-13.

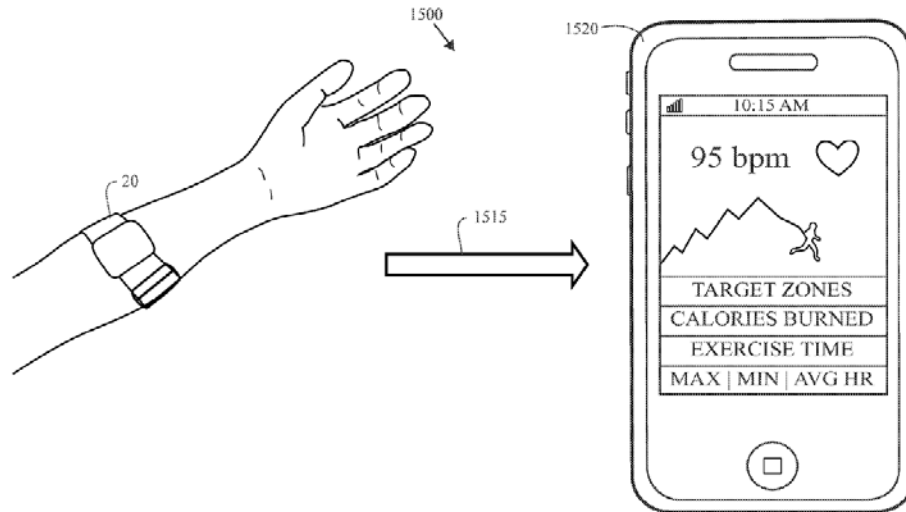

FIG. 26

A POSA would have understood that a smartphone as described in Rulkov is compatible with Lisogurski's wireless sensor, and that the smartphone could be used as a monitor in that configuration. Ex.1011, 14:64-15:3, 18:28-31; Ex.1003, ¶¶209-10, 212-13. Lisogurski's monitor, as implemented on a smartphone as taught by Rulkov, meets all of the elements of claim 5. Ex.1003, ¶213.

#### **D. No Secondary Considerations Exist**

As described above, Lisogurski and Carlson alone or further in view of Rulkov teaches systems that render *prima facie* obvious the challenged claims of the '698 patent. No secondary indicia of non-obviousness exist having a nexus to the putative "invention" of the '698 patent contrary to that conclusion. Apple

reserves its right to respond to any assertion of secondary indicia of non-obviousness advanced by Patent Owner.

**VII. Conclusion**

Petitioner respectfully submits that the evidence presented in this Petition establishes a reasonable likelihood that Petitioner will prevail in establishing the challenged claims are unpatentable, and requests that Trial be instituted.

Dated: April 10, 2019

Respectfully Submitted,

Ching-Lee Fukuda  
Reg. No. 44,334  
Sidley Austin LLP  
787 Seventh Avenue  
New York, NY 10019  
clfukuda@sidley.com  
(212) 839-7364

/Jeffrey P. Kushan/  
Jeffrey P. Kushan  
Registration No. 43,401  
Sidley Austin LLP  
1501 K Street NW  
Washington, DC 20005  
jkushan@sidley.com  
(202) 736-8914

*Lead Counsel for Petitioner*

Thomas A. Broughan III  
Reg. No. 66,001  
Kathi Cover  
Reg. No. 37,803  
Sidley Austin LLP  
1501 K Street NW  
Washington, DC 20005  
tbroughan@sidley.com  
kcover@sidley.com  
(202) 736-8314

*Backup Lead Counsel for Petitioner*



**Claim Appendix**

1. A wearable device, comprising:
  - [1.a] a measurement device including a light source comprising a plurality of light emitting diodes (LEDs) for measuring one or more physiological parameters, the measurement device configured to generate, by modulating at least one of the LEDs having an initial light intensity, an input optical beam having one or more optical wavelengths, wherein at least a portion of the one or more optical wavelengths is a near-infrared wavelength between 700 nanometers and 2500 nanometers;
  - [1.b] the measurement device comprising one or more lenses configured to receive and to deliver a portion of the input optical beam to tissue, wherein the tissue reflects at least a portion of the input optical beam delivered to the tissue;
  - [1.c] the measurement device further comprising a receiver, wherein the receiver includes a plurality of spatially separated detectors, the detectors configured to:
    - [1.c.i] capture light while the LEDs are off and convert the captured light into a first signal; and
    - [1.c.ii] capture light while at least one of the LEDs is on and convert the captured light into a second signal, the captured light including at least a portion of the input optical beam reflected from the tissue;
  - [1.d] wherein at least one analog to digital converter is coupled to the spatially separated detectors and is configured to generate at least a first data signal from the first signal and at least a second data signal from the second signal;

- [1.e] the measurement device configured to improve a signal-to-noise ratio of the input optical beam reflected from the tissue by differencing the first data signal and the second data signal to generate an output signal representing at least in part a non-invasive measurement on blood contained within the tissue; and
- [1.f] wherein the modulating at least one of the LEDs has a modulation frequency, and wherein the receiver is configured to use a lock-in technique that detects the modulation frequency.
2. The wearable device of claim 1, wherein the plurality of LEDs and the plurality of spatially separated detectors are mounted on a common structure, and wherein the plurality of LEDs are coupled electrically to a power supply.
  3. The wearable device of claim 1, wherein the light source is configured to further improve the signal-to-noise ratio of the input beam reflected from the tissue by increasing the light intensity relative to the initial light intensity from at least one of the LEDs, and wherein the receiver is configured to be synchronized to at least one of the LEDs.
  5. The wearable device of claim 1, wherein the wearable device is configured to communicate with a smart phone or tablet, the smart phone or tablet comprising a wireless receiver, a wireless transmitter, a display, a voice input module, a speaker, and a touch screen, the smart phone or tablet configured to receive and to process at least a portion of the output signal, wherein

the smart phone or tablet is configured to store and display the processed output signal, wherein at least a portion of the processed output signal is configured to be transmitted over a wireless transmission link.

**CERTIFICATE OF COMPLIANCE**

I hereby certify that this brief complies with the type-volume limitations of 37 C.F.R. § 42.24, because it contains 13,818 words (as determined by the Microsoft Word word-processing system used to prepare the brief), excluding the parts of the brief exempted by 37 C.F.R. § 42.24.

Dated: April 10, 2019

Respectfully Submitted,

/Jeffrey P. Kushan/  
Jeffrey P. Kushan  
Reg. No. 43,401  
SIDLEY AUSTIN LLP  
1501 K Street NW  
Washington, DC 20005  
*Attorney for Petitioner*

**CERTIFICATE OF SERVICE**

I hereby certify that on the 10th day of April, 2019, copies of this Petition for *Inter Partes* Review, Attachments and Exhibits will be served in its entirety by U.S. mail on the following counsel of record for Patent Owner:

David Bir  
Brooks, Kushman P.C./Cheetah  
Omni MedSci  
1000 Town Center  
Twenty Second Floor  
Southfield, MI 48075

Dr. Mohammed N. Islam  
Omni MedSci, Inc.  
1718 Newport Creek Drive,  
Ann Arbor, Michigan 48103

Honigman LLP  
c/o Sarah Waidelich  
315 E Eisenhower Pkwy  
Ann Arbor, MI 48108

Regents of Michigan  
Office of Technology Transfer  
c/o Richard Brandon  
1600 Huron Pkwy, Building 520,  
2nd Floor  
Ann Arbor, MI 48109-2590

Thomas A. Lewry  
John S. LeRoy  
Robert C. Tuttle  
John M. Halan  
Christopher C. Smith  
Brooks, Kushman P.C./Cheetah  
Omni MedSci  
1000 Twon Center  
Twenty Second Floor  
Southfield, MI 48075

I further certify that on the 10th day of April, 2019, copies of this Petition for *Inter Partes* Review, Attachments and Exhibits have been served in its entirety by U.S. mail on the following counsel of record for Patent Owner:

T. John Ward, Jr.  
Claire Abernathy Henry  
WARD, SMITH & HILL, PLLC  
P.O. Box 1231  
Longview, Texas 75606

Dated: April 10, 2019

Respectfully submitted,

/Jeffrey P. Kushan/  
Jeffrey P. Kushan  
Reg. No. 43,401  
*Attorney for Petitioner*