



US012109384B2

(12) **United States Patent**
Merritt et al.

(10) **Patent No.:** **US 12,109,384 B2**

(45) **Date of Patent:** **Oct. 8, 2024**

(54) **HEMOSTASIS VALVES AND METHODS OF USE**

(71) Applicant: **Inari Medical, Inc.**, Irvine, CA (US)

(72) Inventors: **Benjamin E. Merritt**, San Clemente, CA (US); **John C. Thress**, Capistrano Beach, CA (US); **Paul Lubock**, Monarch Beach, CA (US)

(73) Assignee: **Inari Medical, Inc.**, Irvine, CA (US)

(*) Notice: Subject to any disclaimer, the term of this patent is extended or adjusted under 35 U.S.C. 154(b) by 0 days.

(21) Appl. No.: **18/598,482**

(22) Filed: **Mar. 7, 2024**

(65) **Prior Publication Data**

US 2024/0207593 A1 Jun. 27, 2024

Related U.S. Application Data

(63) Continuation of application No. 18/515,079, filed on Nov. 20, 2023, which is a continuation of application (Continued)

(51) **Int. Cl.**

A61M 39/06 (2006.01)

A61B 17/3207 (2006.01)

(52) **U.S. Cl.**

CPC **A61M 39/0613** (2013.01); **A61B 17/3207** (2013.01); **A61M 2039/062** (2013.01); **A61M 2039/0673** (2013.01)

(58) **Field of Classification Search**

CPC **A61M 2039/062**; **A61M 2039/0673**; **A61M 39/0613**

See application file for complete search history.

(56) **References Cited**

U.S. PATENT DOCUMENTS

1,101,890 A 6/1914 Tunstead
2,784,717 A 3/1957 Thompson

(Continued)

FOREIGN PATENT DOCUMENTS

AU 2015210338 8/2015
CN 102186427 9/2011

(Continued)

OTHER PUBLICATIONS

Gibbs, et al., "Temporary Stent as a bail-out device during percutaneous transluminal coronary angioplasty: preliminary clinical experience," British Heart Journal, 1994, 71:372-377, Oct. 12, 1993, 6 pgs.

(Continued)

Primary Examiner — Quynh-Nhu H. Vu

(74) *Attorney, Agent, or Firm* — Perkins Coie LLP

(57)

ABSTRACT

Devices, systems, and methods for sealing medical devices, particularly during intravascular access, are disclosed herein. Some aspects relate to a hemostatic valve for sealing a wide range of medical devices, such as catheters, wires, embolectomy systems. The valve can include an elongate member having a first end, a second end, and a central lumen extending therebetween. A reinforcement structure extends along at least a portion of the elongate member and is coupled to the elongate member. A shell defining a first aperture and a second aperture may be included, which first and second apertures can be fluidly coupled by the elongate member. A tensioning mechanism is coupled to the shell and to the elongate member, the tensioning mechanism can be moveable between a first configuration wherein the tensioning mechanism is collapsed and the central lumen is sealed and a second configuration wherein the central lumen is open.

30 Claims, 10 Drawing Sheets

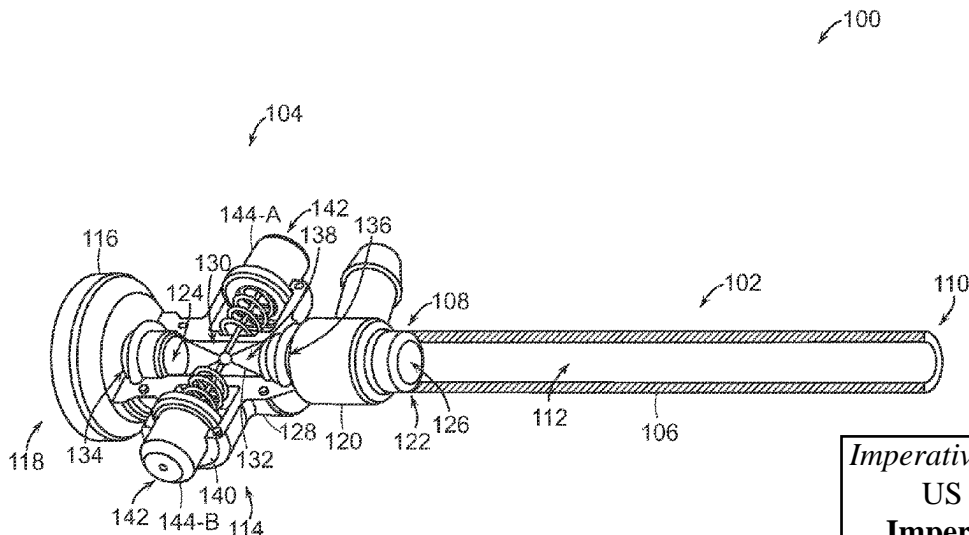

Imperative Care v. Inari Medical
US Patent 12,109,384
Imperative Care Ex. 1001

Related U.S. Application Data

No. 17/226,318, filed on Apr. 9, 2021, now Pat. No. 11,844,921, which is a continuation of application No. 16/117,519, filed on Aug. 30, 2018, now Pat. No. 11,000,682.

(60) Provisional application No. 62/554,931, filed on Sep. 6, 2017.

(56) **References Cited**

U.S. PATENT DOCUMENTS

2,846,179 A * 8/1958 Monckton F16K 7/04
222/507

2,955,592 A 10/1960 Maclean

3,088,363 A 5/1963 Sparks

3,197,173 A * 7/1965 Taubenheim F16K 7/04
24/527

3,383,131 A * 5/1968 Rosfelder E21B 25/06
251/74

3,416,531 A 12/1968 Edwards

3,435,826 A 4/1969 Fogarty

3,438,607 A 4/1969 Williams et al.

3,515,137 A 6/1970 Santomieri

3,661,144 A 5/1972 Jensen et al.

3,675,657 A * 7/1972 Gauthier A61B 17/132
606/203

3,785,380 A 1/1974 Brumfield

3,860,006 A 1/1975 Patel

3,863,624 A 2/1975 Gram

3,892,161 A 7/1975 Sokol

3,923,065 A 12/1975 Nozick et al.

4,030,503 A 6/1977 Clark, III

4,034,642 A 7/1977 Iannucci et al.

4,222,380 A 9/1980 Terayama

4,243,040 A 1/1981 Beecher

4,287,808 A 9/1981 Leonard et al.

4,324,262 A 4/1982 Hall

4,393,872 A 7/1983 Reznik et al.

4,401,107 A 8/1983 Harber et al.

4,469,100 A 9/1984 Hardwick

4,523,738 A 6/1985 Raftis et al.

4,551,862 A * 11/1985 Haber A61F 2/0036
600/491

4,604,094 A 8/1986 Shook

4,611,594 A 9/1986 Grayhack et al.

4,634,421 A 1/1987 Hegemann

4,643,184 A 2/1987 Mobin-Uddin

4,646,736 A 3/1987 Auth et al.

4,650,466 A 3/1987 Luther

4,705,518 A * 11/1987 Baker A61F 2/0036
128/899

4,776,337 A 10/1988 Palmaz

4,790,812 A 12/1988 Hawkins, Jr. et al.

4,863,440 A 9/1989 Chin et al.

4,870,953 A 10/1989 DonMichael et al.

4,883,458 A 11/1989 Shiber

4,886,062 A 12/1989 Wiktor

4,890,611 A 1/1990 Monfort et al.

4,898,575 A 2/1990 Fischell et al.

4,946,440 A 8/1990 Hall

4,960,259 A 10/1990 Sunnavader et al.

4,978,341 A 12/1990 Niederhauser

4,981,478 A 1/1991 Evard et al.

5,030,201 A 7/1991 Palestrant

5,059,178 A 10/1991 Ya

5,100,423 A 3/1992 Fearnot

5,127,626 A 7/1992 Hilal et al.

5,129,910 A 7/1992 Phan et al.

5,135,484 A 8/1992 Wright

5,154,724 A 10/1992 Andrews

5,158,533 A 10/1992 Strauss et al.

5,158,564 A 10/1992 Schnepf-Pesch et al.

5,192,274 A 3/1993 Bierman

5,192,286 A 3/1993 Phan et al.

5,192,290 A 3/1993 Hilal

5,197,485 A 3/1993 Grooters

5,234,403 A 8/1993 Yoda et al.

5,242,461 A 9/1993 Kortenbach et al.

5,244,619 A 9/1993 Burnham

5,323,514 A 6/1994 Masuda et al.

5,329,923 A 7/1994 Lundquist

5,360,417 A 11/1994 Gravener et al.

5,364,345 A 11/1994 Lowery et al.

5,376,101 A 12/1994 Green et al.

5,383,887 A 1/1995 Nadal

5,389,100 A 2/1995 Bacich et al.

5,391,152 A 2/1995 Patterson et al.

5,419,774 A 5/1995 Willard et al.

5,421,824 A 6/1995 Clement et al.

5,443,443 A 8/1995 Shiber

5,456,667 A 10/1995 Ham et al.

5,476,450 A 12/1995 Ruggio

5,484,418 A * 1/1996 Quiachon A61M 25/005
604/167.03

5,490,859 A 2/1996 Mische et al.

5,496,365 A 3/1996 Sgro

5,527,326 A 6/1996 Hermann et al.

5,549,626 A 8/1996 Miller et al.

5,591,137 A 1/1997 Stevens

5,639,276 A 6/1997 Weinstock et al.

5,653,684 A 8/1997 Laptewicz et al.

5,662,703 A 9/1997 Yurek et al.

5,746,758 A 5/1998 Nordgren et al.

5,749,858 A 5/1998 Cramer

5,769,816 A 6/1998 Barbut et al.

5,782,817 A 7/1998 Franzel et al.

5,800,457 A 9/1998 Gelbfish

5,827,229 A 10/1998 Auth et al.

5,846,251 A 12/1998 Hart

5,860,938 A 1/1999 Lafontaine et al.

5,873,866 A 2/1999 Kondo et al.

5,873,882 A 2/1999 Straub et al.

5,876,414 A 3/1999 Straub

5,895,406 A 4/1999 Gray et al.

5,908,435 A 6/1999 Samuels

5,911,710 A 6/1999 Barry et al.

5,911,728 A 6/1999 Sepetka et al.

5,911,733 A 6/1999 Parodi

5,911,754 A 6/1999 Kanesaka et al.

5,941,869 A 8/1999 Patterson et al.

5,947,985 A 9/1999 Imram

5,951,539 A 9/1999 Nita et al.

5,954,737 A 9/1999 Lee

5,971,938 A 10/1999 Hart et al.

5,971,958 A 10/1999 Zhang

5,972,019 A 10/1999 Engelson et al.

5,974,938 A 11/1999 Lloyd

5,989,233 A 11/1999 Yoon

5,993,483 A 11/1999 Gianotti

6,017,335 A 1/2000 Burnham

6,030,397 A 2/2000 Moneti et al.

6,059,745 A 5/2000 Gelbfish

6,059,814 A 5/2000 Ladd

6,066,158 A 5/2000 Engelson et al.

6,068,645 A 5/2000 Tu

6,126,635 A 10/2000 Simpson et al.

6,142,987 A 11/2000 Tsugita

6,146,396 A 11/2000 Konya et al.

6,146,403 A 11/2000 St. Germain

6,152,144 A 11/2000 Lesh et al.

6,152,946 A 11/2000 Broome et al.

6,156,055 A 12/2000 Ravenscroft

6,159,230 A 12/2000 Samuels

6,165,196 A 12/2000 Stack et al.

6,168,579 B1 1/2001 Tsugita

6,179,859 B1 1/2001 Bates et al.

6,221,006 B1 4/2001 Dubrul et al.

6,228,060 B1 5/2001 Howell

6,238,412 B1 5/2001 Dubrul et al.

6,245,078 B1 6/2001 Ouchi

6,245,089 B1 6/2001 Daniel et al.

6,254,571 B1 7/2001 Hart

6,258,115 B1 7/2001 Dubrul

6,264,663 B1 7/2001 Cano

(56)

References Cited

U.S. PATENT DOCUMENTS

6,306,163	B1	10/2001	Fitz	7,128,073	B1	10/2006	van der Burg et al.
6,322,572	B1	11/2001	Lee	7,152,605	B2	12/2006	Khairkhan et al.
6,350,271	B1	2/2002	Kurz et al.	7,179,273	B1	2/2007	Palmer et al.
6,361,545	B1	3/2002	Macoviak et al.	7,223,253	B2	5/2007	Hogendijk
6,364,895	B1	4/2002	Greenhalgh	7,232,432	B2	6/2007	Fulton, III et al.
6,368,339	B1	4/2002	Amplatz	7,244,243	B2	7/2007	Lary
6,383,205	B1	5/2002	Samson et al.	7,285,126	B2	10/2007	Sepetka et al.
6,402,771	B1	6/2002	Palmer et al.	7,300,458	B2	11/2007	Henkes et al.
6,413,235	B1	7/2002	Parodi	7,306,618	B2	12/2007	Demond et al.
6,423,032	B2	7/2002	Parodi	7,320,698	B2	1/2008	Eskuri
6,432,122	B1	8/2002	Gilson et al.	7,323,002	B2	1/2008	Johnson et al.
6,451,036	B1	9/2002	Heitzmann et al.	7,331,980	B2	2/2008	Dubrul et al.
6,458,103	B1	10/2002	Albert et al.	7,481,805	B2	1/2009	Magnusson
6,475,236	B1	11/2002	Roubin et al.	7,534,234	B2	5/2009	Fotjik
6,485,502	B2	11/2002	Don Michael	7,578,830	B2	8/2009	Kusleika et al.
6,508,782	B1	1/2003	Evans et al.	7,621,870	B2	11/2009	Berrada et al.
6,511,492	B1	1/2003	Rosenbluth et al.	7,674,247	B2	3/2010	Fotjik
6,514,273	B1	2/2003	Voss et al.	7,678,131	B2	3/2010	Muller
6,530,923	B1	3/2003	Dubrul et al.	7,691,121	B2	4/2010	Rosenbluth et al.
6,530,935	B2	3/2003	Wensel et al.	7,695,458	B2	4/2010	Belley et al.
6,540,722	B1	4/2003	Boyle et al.	7,713,282	B2	5/2010	Frazier et al.
6,544,276	B1	4/2003	Azizi	7,722,641	B2	5/2010	van der Burg et al.
6,544,278	B1	4/2003	Vrba et al.	7,763,010	B2	7/2010	Evans et al.
6,544,279	B1	4/2003	Hopkins et al.	7,766,934	B2	8/2010	Pal et al.
6,551,342	B1	4/2003	Shen et al.	7,775,501	B2	8/2010	Kees
6,564,828	B1	5/2003	Ishida	7,780,696	B2	8/2010	Daniel et al.
6,569,181	B1	5/2003	Burns	7,815,608	B2	10/2010	Schafersman et al.
6,575,995	B1	6/2003	Huter et al.	7,905,877	B1	3/2011	Oscar et al.
6,589,263	B1	7/2003	Hopkins et al.	7,905,896	B2	3/2011	Straub
6,589,264	B1	7/2003	Barbut et al.	7,938,809	B2	5/2011	Lampropoulos et al.
6,596,011	B2	7/2003	Johnson et al.	7,938,820	B2	5/2011	Webster et al.
6,602,271	B2	8/2003	Adams et al.	7,967,790	B2	6/2011	Whiting et al.
6,605,074	B2	8/2003	Zadno-azizi et al.	7,976,511	B2	7/2011	Fotjik
6,605,102	B1	8/2003	Mazzocchi et al.	7,993,302	B2	8/2011	Hebert et al.
6,610,077	B1	8/2003	Hancock et al.	7,993,363	B2	8/2011	Demond et al.
6,620,148	B1	9/2003	Tsugita	8,021,351	B2	9/2011	Boldenow et al.
6,620,179	B2	9/2003	Brook et al.	8,043,313	B2	10/2011	Krolik et al.
6,620,182	B1	9/2003	Khosravi et al.	8,052,640	B2	11/2011	Fiorella et al.
6,623,460	B1	9/2003	Heck	8,057,496	B2	11/2011	Fischer, Jr.
6,635,068	B1	10/2003	Dubrul et al.	8,057,497	B1	11/2011	Raju et al.
6,645,222	B1	11/2003	Parodi et al.	8,066,757	B2	11/2011	Ferrera et al.
6,660,013	B2	12/2003	Rabiner et al.	8,070,694	B2	12/2011	Galdonik et al.
6,660,014	B2	12/2003	Demarais et al.	8,070,769	B2	12/2011	Broome
6,663,650	B2	12/2003	Sepetka et al.	8,070,791	B2	12/2011	Ferrera et al.
6,692,504	B2	2/2004	Kurz et al.	8,075,510	B2	12/2011	Aklog et al.
6,699,260	B2	3/2004	Dubrul et al.	8,080,032	B2	12/2011	van der Burg et al.
6,702,830	B1	3/2004	Demarais et al.	8,088,140	B2	1/2012	Ferrera et al.
6,719,717	B1	4/2004	Johnson et al.	8,092,486	B2	1/2012	Berrada et al.
6,755,847	B2	6/2004	Eskuri	8,100,935	B2	1/2012	Rosenbluth et al.
6,767,353	B1	7/2004	Shiber	8,109,962	B2	2/2012	Pal
6,790,204	B2	9/2004	Zadno-azizi et al.	8,118,275	B2*	2/2012	Mialhe A61M 39/0613 251/294
6,800,080	B1	10/2004	Bates	8,118,829	B2	2/2012	Carrison et al.
6,818,006	B2	11/2004	Douk et al.	8,187,465	B2	5/2012	Nierich
6,824,545	B2	11/2004	Sepetka et al.	8,197,493	B2	6/2012	Ferrera et al.
6,824,550	B1	11/2004	Noriega et al.	8,246,641	B2	8/2012	Osborne et al.
6,824,553	B1	11/2004	Gene et al.	8,261,648	B1	9/2012	Marchand et al.
6,830,561	B2	12/2004	Jansen et al.	8,267,897	B2	9/2012	Wells
6,846,029	B1	1/2005	Ragner et al.	8,298,257	B2	10/2012	Sepetka et al.
6,902,540	B2	6/2005	Dorros et al.	8,317,748	B2	11/2012	Fiorella et al.
6,908,455	B2	6/2005	Hajianpour	8,337,450	B2	12/2012	Fotjik
6,939,361	B1	9/2005	Kleshinski	RE43,902	E	1/2013	Hopkins et al.
6,942,682	B2	9/2005	Vrba et al.	8,343,167	B2	1/2013	Henson
6,945,977	B2	9/2005	Demarais et al.	8,357,178	B2	1/2013	Grandfield et al.
6,960,189	B2	11/2005	Bates et al.	8,361,104	B2	1/2013	Jones et al.
6,960,222	B2	11/2005	Vo et al.	8,409,215	B2	4/2013	Sepetka et al.
7,004,931	B2	2/2006	Hogendijk	8,439,858	B2	5/2013	Huang et al.
7,004,954	B1	2/2006	Voss et al.	8,480,708	B2	7/2013	Kassab et al.
7,036,707	B2	5/2006	Aota et al.	8,486,105	B2	7/2013	Demond et al.
7,041,084	B2	5/2006	Fotjik	8,491,539	B2	7/2013	Fotjik
7,052,500	B2	5/2006	Bashiri et al.	8,512,352	B2	8/2013	Martin
7,056,328	B2	6/2006	Arnott	8,523,897	B2	9/2013	van der Burg et al.
7,063,707	B2	6/2006	Bose et al.	8,529,596	B2	9/2013	Grandfield et al.
7,069,835	B2	7/2006	Nishri et al.	8,535,283	B2	9/2013	Heaton et al.
7,094,249	B1	8/2006	Thomas et al.	8,535,334	B2	9/2013	Martin
7,122,034	B2	10/2006	Belhe et al.	8,535,343	B2	9/2013	van der Burg et al.
				8,545,526	B2	10/2013	Martin et al.
				8,568,432	B2	10/2013	Straub
				8,568,465	B2	10/2013	Freudenthal et al.

(56)

References Cited

U.S. PATENT DOCUMENTS

8,574,262 B2	11/2013	Ferrera et al.	9,700,332 B2	7/2017	Marchand et al.
8,579,915 B2	11/2013	French et al.	9,717,488 B2	8/2017	Kassab et al.
8,585,713 B2	11/2013	Ferrera et al.	9,717,514 B2	8/2017	Martin et al.
8,608,754 B2	12/2013	Wensel et al.	9,717,519 B2	8/2017	Rosenbluth et al.
8,632,584 B2	1/2014	Henkes et al.	9,744,024 B2	8/2017	Nguyen et al.
8,647,367 B2	2/2014	Kassab et al.	9,757,137 B2	9/2017	Krolik et al.
8,657,867 B2	2/2014	Dorn et al.	9,827,084 B2	11/2017	Bonnette et al.
8,696,622 B2	4/2014	Fiorella et al.	9,827,364 B2	11/2017	Peticca et al.
8,715,314 B1	5/2014	Janardhan et al.	9,844,386 B2	12/2017	Nguyen et al.
8,721,714 B2	5/2014	Kelley	9,844,387 B2	12/2017	Marchand et al.
8,753,322 B2	6/2014	Hu et al.	9,848,975 B2	12/2017	Hauser
8,771,289 B2	7/2014	Mohiuddin et al.	9,849,014 B2	12/2017	Kusleika
8,777,893 B2	7/2014	Malewicz	9,884,387 B2	2/2018	Plha
8,784,441 B2	7/2014	Rosenbluth et al.	9,962,178 B2	5/2018	Greenhalgh et al.
8,784,442 B2	7/2014	Jones et al.	9,980,813 B2*	5/2018	Eller F16K 7/06
8,784,469 B2	7/2014	Kassab	9,999,493 B2	6/2018	Nguyen et al.
8,795,305 B2	8/2014	Martin et al.	10,004,531 B2	6/2018	Rosenbluth et al.
8,795,317 B2	8/2014	Grandfield et al.	10,010,335 B2	7/2018	Greenhalgh et al.
8,795,345 B2	8/2014	Grandfield et al.	10,016,266 B2	7/2018	Hauser
8,801,748 B2	8/2014	Martin	10,028,759 B2	7/2018	Wallace et al.
8,808,259 B2	8/2014	Walton et al.	10,045,790 B2	8/2018	Cox et al.
8,814,927 B2	8/2014	Shin et al.	10,058,339 B2	8/2018	Galdonik et al.
8,820,207 B2	9/2014	Marchand et al.	10,098,651 B2	10/2018	Marchand et al.
8,826,791 B2	9/2014	Thompson et al.	10,130,385 B2	11/2018	Farhangnia et al.
8,828,044 B2	9/2014	Aggerholm et al.	10,183,159 B2*	1/2019	Nobles F16K 31/445
8,833,224 B2	9/2014	Thompson et al.	10,226,263 B2	3/2019	Look et al.
8,834,519 B2	9/2014	van der Burg et al.	10,238,406 B2	3/2019	Cox et al.
8,845,621 B2	9/2014	Fotjik	10,271,864 B2	4/2019	Greenhalgh et al.
8,852,205 B2	10/2014	Brady et al.	10,327,883 B2	6/2019	Yachia
8,852,226 B2	10/2014	Gilson et al.	10,335,186 B2	7/2019	Rosenbluth et al.
8,939,991 B2	1/2015	Krolik et al.	10,342,571 B2	7/2019	Marchand et al.
8,945,143 B2	2/2015	Ferrera et al.	10,349,960 B2	7/2019	Quick
8,945,172 B2	2/2015	Ferrera et al.	10,383,644 B2	8/2019	Molaei et al.
8,956,384 B2	2/2015	Berrada et al.	10,384,034 B2	8/2019	Carrison et al.
8,992,504 B2	3/2015	Castella et al.	10,426,644 B2	10/2019	Shrivastava et al.
9,005,172 B2	4/2015	Chung	10,456,151 B2	10/2019	Slee et al.
9,011,551 B2	4/2015	Oral et al.	10,456,555 B2	10/2019	Carrison et al.
9,028,401 B1	5/2015	Bacich et al.	10,478,535 B2	11/2019	Ogle
9,072,537 B2	7/2015	Grandfield et al.	10,485,952 B2	11/2019	Carrison et al.
9,078,682 B2	7/2015	Lenker et al.	10,524,811 B2	1/2020	Marchand et al.
9,101,382 B2	8/2015	Krolik et al.	10,531,883 B1	1/2020	Deville et al.
9,125,683 B2	9/2015	Farhangnia et al.	10,588,655 B2	3/2020	Rosenbluth et al.
9,126,016 B2	9/2015	Fulton	10,648,268 B2	5/2020	Jaffrey et al.
9,149,609 B2	10/2015	Ansel et al.	10,695,159 B2	6/2020	Hauser
9,155,552 B2	10/2015	Ulm, III	10,709,471 B2	7/2020	Rosenbluth et al.
9,161,766 B2	10/2015	Slee et al.	10,772,636 B2	9/2020	Kassab et al.
9,168,043 B2	10/2015	van der Burg et al.	10,799,331 B2	10/2020	Hauser
9,173,668 B2	11/2015	Ulm, III	10,912,577 B2	2/2021	Marchand et al.
9,186,487 B2	11/2015	Dubrul et al.	10,926,060 B2	2/2021	Stern et al.
9,204,887 B2	12/2015	Cully et al.	10,953,195 B2	3/2021	Jalgaonkar et al.
9,216,277 B2	12/2015	Myers	10,960,114 B2	3/2021	Goisis
9,241,669 B2	1/2016	Pugh et al.	10,967,111 B2	4/2021	Iida
9,358,037 B2	1/2016	Farhangnia et al.	10,994,063 B2	5/2021	Fisher et al.
9,259,237 B2	2/2016	Quick et al.	11,000,682 B2	5/2021	Merritt et al.
9,265,512 B2	2/2016	Carrison et al.	11,013,523 B2	5/2021	Arad Hadar
9,283,066 B2	3/2016	Hopkins et al.	11,058,445 B2	7/2021	Cox et al.
9,301,769 B2	4/2016	Brady et al.	11,058,451 B2	7/2021	Marchand et al.
9,351,747 B2	5/2016	Kugler et al.	11,065,019 B1	7/2021	Chou et al.
9,439,664 B2	9/2016	Sos	11,147,571 B2	10/2021	Cox et al.
9,439,751 B2	9/2016	White et al.	11,154,314 B2	10/2021	Quick
9,456,834 B2	10/2016	Folk	11,166,703 B2	11/2021	Kassab et al.
9,463,035 B1	10/2016	Greenhalgh et al.	11,185,664 B2	11/2021	Carrison et al.
9,463,036 B2	10/2016	Brady et al.	11,213,356 B2	1/2022	Tanner et al.
9,526,864 B2	12/2016	Quick	11,224,450 B2	1/2022	Chou et al.
9,526,865 B2	12/2016	Quick	11,224,721 B2	1/2022	Carrison et al.
9,532,792 B2	1/2017	Galdonik et al.	11,259,821 B2	3/2022	Buck et al.
9,566,073 B2	2/2017	Kassab et al.	11,266,825 B2	3/2022	Peter et al.
9,566,179 B2	2/2017	Andreas et al.	11,305,094 B2	4/2022	Carrison et al.
9,566,424 B2	2/2017	Pessin	11,337,714 B2	5/2022	Ferrera et al.
9,579,116 B1	2/2017	Nguyen et al.	11,383,064 B2	7/2022	Carrison et al.
9,581,942 B1	2/2017	Shippert	11,395,903 B2	7/2022	Carrison et al.
9,616,213 B2	4/2017	Furnish et al.	11,406,801 B2	8/2022	Fojtik et al.
9,636,206 B2	5/2017	Nguyen et al.	11,433,218 B2	9/2022	Quick et al.
9,643,035 B2	5/2017	Mastenbroek	11,439,799 B2	9/2022	Buck et al.
9,662,129 B2	5/2017	Galdonik et al.	11,457,936 B2	10/2022	Buck et al.
			11,529,158 B2	12/2022	Hauser
			11,554,005 B2	1/2023	Merritt et al.
			11,559,382 B2	1/2023	Merritt et al.
			11,576,691 B2	2/2023	Chou et al.

(56)

References Cited

U.S. PATENT DOCUMENTS

11,596,768 B2	3/2023	Stern et al.	2004/0039351 A1	2/2004	Barrett
11,607,483 B2	3/2023	Iida	2004/0039412 A1	2/2004	Isshiki et al.
11,642,209 B2	5/2023	Merritt et al.	2004/0068288 A1	4/2004	Palmer et al.
11,648,028 B2	5/2023	Rosenbluth et al.	2004/0073243 A1	4/2004	Sepetka et al.
11,697,011 B2	7/2023	Merritt et al.	2004/0098033 A1	5/2004	Leefflang et al.
11,697,012 B2	7/2023	Merritt et al.	2004/0102807 A1	5/2004	Kusleika et al.
11,744,691 B2	9/2023	Merritt et al.	2004/0122359 A1	6/2004	Wenz et al.
11,806,033 B2	11/2023	Marchand et al.	2004/0127936 A1	7/2004	Salahieh et al.
11,832,837 B2	12/2023	Hauser	2004/0133232 A1	7/2004	Rosenbluth et al.
11,832,838 B2	12/2023	Hauser	2004/0138525 A1	7/2004	Saadat et al.
11,833,023 B2	12/2023	Hauser	2004/0138692 A1	7/2004	Phung et al.
11,839,393 B2	12/2023	Hauser	2004/0167567 A1	8/2004	Cano et al.
11,844,921 B2	12/2023	Merritt et al.	2004/0199201 A1	10/2004	Kellett et al.
11,849,963 B2	12/2023	Quick	2004/0199202 A1	10/2004	Dubrul et al.
11,865,291 B2	1/2024	Merritt et al.	2004/0260344 A1	12/2004	Lyons et al.
11,890,180 B2	2/2024	Merritt et al.	2004/0267272 A1	12/2004	Henniges et al.
11,918,243 B2	3/2024	Marchand et al.	2005/0004534 A1	1/2005	Lockwood et al.
11,918,244 B2	3/2024	Marchand et al.	2005/0033172 A1	2/2005	Dubrul et al.
11,925,369 B2	3/2024	Hauser	2005/0038468 A1	2/2005	Panetta et al.
11,937,834 B2	3/2024	Dinh	2005/0054995 A1	3/2005	Barzell et al.
11,937,838 B2	3/2024	Cox et al.	2005/0055047 A1	3/2005	Greenhalgh
11,963,861 B2	4/2024	Strauss et al.	2005/0080398 A1	4/2005	Markel et al.
11,969,178 B2	4/2024	Hauser	2005/0085769 A1	4/2005	MacMahon et al.
11,969,331 B2	4/2024	Merritt et al.	2005/0085826 A1	4/2005	Nair et al.
11,969,332 B2	4/2024	Merritt et al.	2005/0085846 A1	4/2005	Carrison et al.
11,969,333 B2	4/2024	Merritt et al.	2005/0085849 A1	4/2005	Sepetka et al.
11,974,909 B2	5/2024	Merritt et al.	2005/0119668 A1	6/2005	Teague et al.
11,974,910 B2	5/2024	Merritt et al.	2005/0131387 A1	6/2005	Pursley
11,980,537 B2	5/2024	Merritt et al.	2005/0177132 A1	8/2005	Lentz et al.
11,986,382 B2	5/2024	Merritt et al.	2005/0187570 A1	8/2005	Nguyen et al.
11,998,436 B2	6/2024	Merritt et al.	2005/0203605 A1	9/2005	Dolan
12,016,580 B2	6/2024	Quick et al.	2005/0283165 A1	12/2005	Gadberry
2001/0004699 A1	6/2001	Gittings et al.	2005/0283166 A1	12/2005	Greenhalgh et al.
2001/0031981 A1	10/2001	Evans et al.	2005/0283186 A1	12/2005	Berrada et al.
2001/0041881 A1	11/2001	Sarge et al.	2006/0020286 A1	1/2006	Niermann
2001/0041909 A1	11/2001	Tsugita et al.	2006/0042786 A1	3/2006	West
2001/0049486 A1	12/2001	Evans et al.	2006/0047286 A1	3/2006	West
2001/0051810 A1	12/2001	Dubrul et al.	2006/0074401 A1	4/2006	Ross
2002/0022858 A1	2/2002	Demond et al.	2006/0089533 A1	4/2006	Ziegler et al.
2002/0022859 A1	2/2002	Hogendijk	2006/0100662 A1	5/2006	Daniel et al.
2002/0026211 A1	2/2002	Khosravi et al.	2006/0149219 A1	7/2006	Calderon
2002/0032455 A1	3/2002	Boock et al.	2006/0155305 A1	7/2006	Freudenthal et al.
2002/0049452 A1	4/2002	Kurz et al.	2006/0173525 A1	8/2006	Behl et al.
2002/0095161 A1	7/2002	Dhindsa	2006/0195137 A1	8/2006	Sepetka et al.
2002/0095171 A1	7/2002	Belef	2006/0200221 A1	9/2006	Malewicz
2002/0111648 A1	8/2002	Kusleika et al.	2006/0217664 A1	9/2006	Hattler et al.
2002/0120277 A1	8/2002	Hauschild et al.	2006/0224177 A1	10/2006	Finitis
2002/0147458 A1	10/2002	Hiblar et al.	2006/0229645 A1	10/2006	Bonnette et al.
2002/0151918 A1	10/2002	Lafontaine et al.	2006/0247500 A1	11/2006	Voegele et al.
2002/0156457 A1	10/2002	Fisher	2006/0253145 A1	11/2006	Lucas
2002/0161392 A1	10/2002	Dubrul	2006/0264905 A1	11/2006	Eskridge et al.
2002/0169474 A1	11/2002	Kusleika	2006/0276874 A1	12/2006	Wilson et al.
2002/0173819 A1	11/2002	Leefflang et al.	2006/0282111 A1	12/2006	Morsi
2002/0188276 A1	12/2002	Evans et al.	2006/0293696 A1	12/2006	Fahey et al.
2003/0004536 A1	1/2003	Boylan et al.	2007/0010787 A1	1/2007	Hackett et al.
2003/0023263 A1	1/2003	Krolik et al.	2007/0038225 A1	2/2007	Osborne
2003/0083693 A1	5/2003	Daniel et al.	2007/0093744 A1	4/2007	Elmaleh
2003/0100919 A1	5/2003	Hopkins et al.	2007/0112374 A1	5/2007	Paul, Jr. et al.
2003/0114875 A1	6/2003	Sjostrom	2007/0118165 A1	5/2007	DeMello et al.
2003/0116731 A1*	6/2003	Hartley	2007/0149996 A1	6/2007	Coughlin
		F16K 7/06	2007/0161963 A1	7/2007	Smalling
		251/297	2007/0179513 A1	8/2007	Deutsch
2003/0125663 A1	7/2003	Coleman et al.	2007/0191866 A1	8/2007	Palmer et al.
2003/0135151 A1	7/2003	Deng	2007/0198028 A1	8/2007	Miloslavski et al.
2003/0135230 A1	7/2003	Massey et al.	2007/0208361 A1	9/2007	Okushi et al.
2003/0135258 A1	7/2003	Andreas et al.	2007/0208367 A1	9/2007	Fiorella et al.
2003/0153873 A1	8/2003	Luther et al.	2007/0213753 A1	9/2007	Waller
2003/0153973 A1	8/2003	Soun et al.	2007/0213765 A1	9/2007	Adams et al.
2003/0168068 A1	9/2003	Poole et al.	2007/0233043 A1	10/2007	Dayton et al.
2003/0176884 A1	9/2003	Berrada et al.	2007/0255252 A1	11/2007	Mehta
2003/0191425 A1	10/2003	Rosenblatt et al.	2007/0288054 A1	12/2007	Tanaka et al.
2003/0191516 A1	10/2003	Weldon et al.	2008/0015541 A1	1/2008	Rosenbluth et al.
2003/0208224 A1	11/2003	Broome	2008/0087853 A1	4/2008	Kees
2003/0216774 A1	11/2003	Larson	2008/0088055 A1	4/2008	Ross
2003/0225379 A1	12/2003	Schaffer et al.	2008/0157017 A1	7/2008	Macatangay et al.
2004/0019310 A1	1/2004	Hogendijk	2008/0167678 A1	7/2008	Morsi
			2008/0183136 A1	7/2008	Lenker et al.
			2008/0228209 A1	9/2008	DeMello et al.
			2008/0234715 A1	9/2008	Pesce et al.

(56)

References Cited

U.S. PATENT DOCUMENTS

2008/0234722	A1	9/2008	Bonnette et al.	2012/0138832	A1	6/2012	Townsend
2008/0262528	A1	10/2008	Martin	2012/0143123	A1	6/2012	Agnew
2008/0269798	A1	10/2008	Ramzipoor et al.	2012/0143239	A1	6/2012	Aklog et al.
2008/0294096	A1	11/2008	Uber, III et al.	2012/0165919	A1	6/2012	Cox et al.
2008/0300466	A1	12/2008	Gresham	2012/0172918	A1	7/2012	Fifer et al.
2008/0312681	A1	12/2008	Ansel et al.	2012/0179181	A1	7/2012	Straub et al.
2009/0018566	A1	1/2009	Escudero et al.	2012/0197277	A1	8/2012	Stinis
2009/0054918	A1	2/2009	Henson	2012/0232655	A1	9/2012	Lorrison et al.
2009/0062841	A1	3/2009	Amplatz et al.	2012/0271105	A1	10/2012	Nakamura et al.
2009/0069828	A1	3/2009	Martin et al.	2012/0271231	A1	10/2012	Agrawal
2009/0076417	A1	3/2009	Jones	2012/0277788	A1	11/2012	Cattaneo
2009/0160112	A1	6/2009	Ostrovsky	2012/0310166	A1	12/2012	Huff
2009/0163846	A1	6/2009	Aklog et al.	2013/0030460	A1	1/2013	Marks et al.
2009/0182362	A1	7/2009	Thompson et al.	2013/0035628	A1	2/2013	Garrison et al.
2009/0192495	A1	7/2009	Ostrovsky et al.	2013/0046332	A1	2/2013	Jones et al.
2009/0281525	A1	11/2009	Harding et al.	2013/0066348	A1	3/2013	Fiorella et al.
2009/0292307	A1	11/2009	Razack	2013/0092012	A1	4/2013	Marchand et al.
2009/0299393	A1	12/2009	Martin et al.	2013/0096571	A1	4/2013	Massicotte et al.
2009/0312786	A1	12/2009	Trask et al.	2013/0102996	A1	4/2013	Strauss
2010/0016837	A1	1/2010	Howat	2013/0116708	A1	5/2013	Ziniti et al.
2010/0030256	A1	2/2010	Dubrul et al.	2013/0116721	A1	5/2013	Takagi et al.
2010/0042136	A1	2/2010	Berrada et al.	2013/0123705	A1	5/2013	Holm et al.
2010/0087844	A1	4/2010	Fischer, Jr.	2013/0126559	A1	5/2013	Cowan et al.
2010/0087850	A1	4/2010	Razack	2013/0144326	A1	6/2013	Brady et al.
2010/0094201	A1	4/2010	Mallaby	2013/0150793	A1	6/2013	Beissel et al.
2010/0106081	A1	4/2010	Brandeis	2013/0165871	A1	6/2013	Fiorella et al.
2010/0114017	A1	5/2010	Lenker et al.	2013/0184703	A1	7/2013	Shireman et al.
2010/0114113	A1	5/2010	Dubrul et al.	2013/0190701	A1	7/2013	Kim
2010/0121312	A1	5/2010	Gielenz et al.	2013/0197454	A1	8/2013	Shibata et al.
2010/0137846	A1	6/2010	Desai et al.	2013/0197567	A1	8/2013	Brady et al.
2010/0190156	A1	7/2010	Van Wordragen et al.	2013/0204297	A1	8/2013	Melsheimer et al.
2010/0204712	A1	8/2010	Mallaby	2013/0226196	A1	8/2013	Smith
2010/0217276	A1	8/2010	Garrison et al.	2013/0270161	A1	10/2013	Kumar et al.
2010/0249815	A1	9/2010	Jantzen et al.	2013/0281788	A1	10/2013	Garrison
2010/0268264	A1	10/2010	Bonnette et al.	2013/0289608	A1	10/2013	Tanaka et al.
2010/0318178	A1	12/2010	Rapaport et al.	2013/0317589	A1	11/2013	Martin et al.
2011/0009950	A1	1/2011	Grandfield et al.	2013/0345739	A1	12/2013	Brady et al.
2011/0034986	A1	2/2011	Chou et al.	2014/0005712	A1	1/2014	Martin
2011/0034987	A1	2/2011	Kennedy	2014/0005713	A1	1/2014	Bowman
2011/0054405	A1	3/2011	Whiting et al.	2014/0005715	A1	1/2014	Castella et al.
2011/0060212	A1	3/2011	Slee et al.	2014/0005717	A1	1/2014	Martin et al.
2011/0071503	A1	3/2011	Takagi et al.	2014/0025048	A1	1/2014	Ward
2011/0118817	A1	5/2011	Gunderson et al.	2014/0031856	A1	1/2014	Martin
2011/0125181	A1	5/2011	Brady et al.	2014/0046133	A1	2/2014	Nakamura et al.
2011/0144592	A1*	6/2011	Wong A61M 39/06 604/175	2014/0046243	A1	2/2014	Ray et al.
2011/0152823	A1	6/2011	Mohiuddin et al.	2014/0052161	A1	2/2014	Cully et al.
2011/0152889	A1	6/2011	Ashland	2014/0074144	A1	3/2014	Shrivastava et al.
2011/0152993	A1	6/2011	Marchand et al.	2014/0121672	A1	5/2014	Folk
2011/0160742	A1	6/2011	Ferrera et al.	2014/0155830	A1	6/2014	Bonnette et al.
2011/0160763	A1	6/2011	Ferrera et al.	2014/0155980	A1	6/2014	Turjman
2011/0190806	A1	8/2011	Wittens	2014/0163615	A1	6/2014	Gadlage et al.
2011/0196309	A1	8/2011	Wells	2014/0180055	A1	6/2014	Glynn et al.
2011/0196414	A1	8/2011	Porter et al.	2014/0180397	A1	6/2014	Gerberding et al.
2011/0213290	A1	9/2011	Chin et al.	2014/0155908	A1	7/2014	Rosenbluth et al.
2011/0213403	A1	9/2011	Aboytes	2014/0188127	A1	7/2014	Dubrul et al.
2011/0224707	A1	9/2011	Miloslavski et al.	2014/0188143	A1	7/2014	Martin et al.
2011/0245807	A1	10/2011	Sakata et al.	2014/0222070	A1	8/2014	Belson et al.
2011/0251629	A1	10/2011	Galdonik et al.	2014/0236219	A1	8/2014	Dubrul et al.
2011/0264132	A1	10/2011	Strauss et al.	2014/0243882	A1	8/2014	Ma
2011/0264133	A1	10/2011	Hanlon et al.	2014/0257253	A1	9/2014	Jemison
2011/0265681	A1	11/2011	Allen et al.	2014/0257363	A1	9/2014	Lippert
2011/0288529	A1	11/2011	Fulton	2014/0276403	A1	9/2014	Follmer et al.
2011/0288572	A1	11/2011	Martin	2014/0296868	A1	10/2014	Garrison et al.
2011/0309037	A1	12/2011	Lee	2014/0303658	A1	10/2014	Bonnette et al.
2011/0319917	A1	12/2011	Ferrera et al.	2014/0318354	A1	10/2014	Thompson et al.
2012/0059309	A1	3/2012	di Palma et al.	2014/0324091	A1	10/2014	Rosenbluth et al.
2012/0059356	A1	3/2012	di Palma et al.	2014/0330286	A1	11/2014	Wallace et al.
2012/0083824	A1	4/2012	Berrada et al.	2014/0336691	A1	11/2014	Jones et al.
2012/0083868	A1	4/2012	Shrivastava	2014/0343593	A1	11/2014	Chin et al.
2012/0089216	A1	4/2012	Rapaport et al.	2014/0364896	A1	12/2014	Consigny
2012/0095448	A1	4/2012	Kajii	2014/0371779	A1	12/2014	Vale et al.
2012/0101480	A1	4/2012	Ingle et al.	2015/0005781	A1	1/2015	Lund-Clausen et al.
2012/0101510	A1	4/2012	Lenker et al.	2015/0005792	A1	1/2015	Ahn
2012/0109109	A1	5/2012	Kaji	2015/0018859	A1	1/2015	Quick et al.
				2015/0018860	A1	1/2015	Quick
				2015/0018929	A1	1/2015	Martin et al.
				2015/0025555	A1	1/2015	Sos
				2015/0032144	A1	1/2015	Holloway
				2015/0059908	A1	3/2015	Mollen

(56)

References Cited

U.S. PATENT DOCUMENTS

2015/0088190	A1	3/2015	Jensen	2017/0303939	A1	10/2017	Greenhalgh et al.
2015/0127035	A1	5/2015	Trapp et al.	2017/0303942	A1	10/2017	Greenhalgh et al.
2015/0133990	A1	5/2015	Davidson	2017/0303947	A1	10/2017	Greenhalgh et al.
2015/0150672	A1	6/2015	Ma	2017/0303948	A1	10/2017	Wallace et al.
2015/0164523	A1	6/2015	Brady et al.	2017/0319221	A1	11/2017	Chu
2015/0164666	A1	6/2015	Johnson et al.	2017/0325839	A1	11/2017	Rosenbluth et al.
2015/0173782	A1	6/2015	Garrison et al.	2017/0340867	A1	11/2017	Accisano, II
2015/0190155	A1	7/2015	Ulm, III	2017/0348014	A1	12/2017	Wallace et al.
2015/0190156	A1	7/2015	Ulm, III	2018/0014840	A1	1/2018	Panian
2015/0196380	A1	7/2015	Berrada et al.	2018/0042623	A1	2/2018	Batiste
2015/0196744	A1	7/2015	Aboytes	2018/0042624	A1	2/2018	Greenhalgh et al.
2015/0209058	A1	7/2015	Ferrera et al.	2018/0042626	A1	2/2018	Greenhalgh et al.
2015/0209165	A1	7/2015	Grandfield et al.	2018/0055999	A1	3/2018	Bare et al.
2015/0238207	A1	8/2015	Cox et al.	2018/0064453	A1	3/2018	Garrison et al.
2015/0250578	A1	9/2015	Cook et al.	2018/0064454	A1	3/2018	Losordo et al.
2015/0265299	A1	9/2015	Cooper et al.	2018/0070968	A1	3/2018	Wallace et al.
2015/0305756	A1	10/2015	Rosenbluth	2018/0092652	A1	4/2018	Marchand et al.
2015/0305859	A1*	10/2015	Eller	2018/0104404	A1	4/2018	Ngo-Chu
			A61F 2/2469	2018/0105963	A1	4/2018	Quick
			623/1.24	2018/0125512	A1	5/2018	Nguyen et al.
2015/0352325	A1	12/2015	Quick	2018/0184912	A1	7/2018	Ai-Ali
2015/0360001	A1	12/2015	Quick	2018/0193043	A1	7/2018	Marchand et al.
2015/0366690	A1	12/2015	Lumauig	2018/0235742	A1	8/2018	Fields et al.
2015/0374391	A1	12/2015	Quick	2018/0236205	A1	8/2018	Krautkremer et al.
2016/0022293	A1	1/2016	Dubrul et al.	2018/0250498	A1	9/2018	Stern et al.
2016/0030708	A1	2/2016	Casiello et al.	2018/0256177	A1	9/2018	Cooper et al.
2016/0038267	A1	2/2016	Allen et al.	2018/0256178	A1	9/2018	Cox et al.
2016/0058540	A1	3/2016	Don Michael	2018/0296240	A1	10/2018	Rosenbluth et al.
2016/0074627	A1	3/2016	Cottone	2018/0344339	A1	12/2018	Cox et al.
2016/0106353	A1	4/2016	Schuetz et al.	2018/0361116	A1	12/2018	Quick et al.
2016/0106448	A1	4/2016	Brady et al.	2019/0000492	A1	1/2019	Casey et al.
2016/0106449	A1	4/2016	Brady et al.	2019/0015298	A1	1/2019	Beatty et al.
2016/0113663	A1	4/2016	Brady et al.	2019/0046219	A1	2/2019	Marchand et al.
2016/0113664	A1	4/2016	Brady et al.	2019/0070401	A1	3/2019	Merritt et al.
2016/0113665	A1	4/2016	Brady et al.	2019/0117244	A1	4/2019	Wallace et al.
2016/0113666	A1	4/2016	Quick	2019/0133622	A1	5/2019	Wallace et al.
2016/0128857	A1	5/2016	Kao	2019/0133623	A1	5/2019	Wallace et al.
2016/0135829	A1	5/2016	Holochwost et al.	2019/0133624	A1	5/2019	Wallace et al.
2016/0143721	A1	5/2016	Rosenbluth	2019/0133625	A1	5/2019	Wallace et al.
2016/0151605	A1	6/2016	Welch et al.	2019/0133626	A1	5/2019	Wallace et al.
2016/0192912	A1	7/2016	Kassab et al.	2019/0133627	A1	5/2019	Wallace et al.
2016/0206344	A1	7/2016	Bruzzo et al.	2019/0150959	A1	5/2019	Cox et al.
2016/0008014	A1	8/2016	Rosenbluth	2019/0216476	A1	7/2019	Barry et al.
2016/0220741	A1	8/2016	Garrison et al.	2019/0223893	A1	7/2019	Gilvary et al.
2016/0220795	A1	8/2016	Korkuch et al.	2019/0231373	A1	8/2019	Quick
2016/0228134	A1	8/2016	Martin et al.	2019/0239910	A1	8/2019	Brady et al.
2016/0262774	A1	9/2016	Honda	2019/0321071	A1	10/2019	Marchand et al.
2016/0262790	A1	9/2016	Rosenbluth et al.	2019/0328411	A1	10/2019	Vale et al.
2016/0287276	A1	10/2016	Cox et al.	2019/0336142	A1	11/2019	Torrie et al.
2016/0367285	A1	12/2016	Sos	2019/0336148	A1	11/2019	Greenhalgh et al.
2017/0014560	A1	1/2017	Minskoff et al.	2019/0365395	A1	12/2019	Tran et al.
2017/0021130	A1	1/2017	Dye	2019/0366036	A1	12/2019	Jalgaonkar et al.
2017/0037548	A1	2/2017	Lee	2019/0366049	A1	12/2019	Hannon et al.
2017/0042571	A1	2/2017	Levi	2020/0022711	A1	1/2020	Look et al.
2017/0049942	A1	2/2017	Conlan et al.	2020/0046368	A1	2/2020	Merritt et al.
2017/0056032	A1	3/2017	Look et al.	2020/0046940	A1	2/2020	Carrison et al.
2017/0058623	A1	3/2017	Jaffrey et al.	2020/0054861	A1	2/2020	Korkuch et al.
2017/0079672	A1	3/2017	Quick	2020/0078029	A1	3/2020	Hansen et al.
2017/0086864	A1	3/2017	Greenhalgh et al.	2020/0113412	A1	4/2020	Jensen
2017/0100142	A1	4/2017	Look et al.	2020/0121334	A1	4/2020	Galdonik et al.
2017/0105743	A1	4/2017	Vale et al.	2020/0129741	A1	4/2020	Kawwas et al.
2017/0105745	A1	4/2017	Rosenbluth et al.	2020/0324079	A1	10/2020	Jalgaonkar et al.
2017/0112514	A1	4/2017	Marchand et al.	2021/0022843	A1	1/2021	Hauser
2017/0113005	A1	4/2017	Linder et al.	2021/0038385	A1	2/2021	Popp et al.
2017/0143359	A1	5/2017	Nguyen et al.	2021/0113224	A1	4/2021	Dinh
2017/0143880	A1	5/2017	Luxon et al.	2021/0128182	A1	5/2021	Teigen et al.
2017/0143938	A1	5/2017	Ogle et al.	2021/0137667	A1	5/2021	Sonnette et al.
2017/0172591	A1	6/2017	Ulm, III	2021/0138194	A1	5/2021	Carrison et al.
2017/0112513	A1	7/2017	Marchand et al.	2021/0154433	A1	5/2021	Casey et al.
2017/0189041	A1	7/2017	Cox et al.	2021/0186541	A1	6/2021	Thress
2017/0196576	A1	7/2017	Long et al.	2021/0205577	A1	7/2021	Jalgaonkar et al.
2017/0233908	A1	8/2017	Kroczyński et al.	2021/0236148	A1	8/2021	Marchand et al.
2017/0238951	A1	8/2017	Yang et al.	2021/0290925	A1	9/2021	Merritt et al.
2017/0252057	A1	9/2017	Bonnette et al.	2021/0315598	A1	10/2021	Buck et al.
2017/0265878	A1	9/2017	Marchand et al.	2021/0316127	A1	10/2021	Buck et al.
2017/0281204	A1	10/2017	Garrison et al.	2021/0330344	A1	10/2021	Rosenbluth et al.
				2021/0378694	A1	12/2021	Thress et al.
				2021/0393278	A1	12/2021	O'Malley et al.
				2021/0404464	A1	12/2021	Patoskie

(56)

References Cited

U.S. PATENT DOCUMENTS

2022/0000505 A1 1/2022 Hauser
 2022/0000506 A1 1/2022 Hauser
 2022/0000507 A1 1/2022 Hauser
 2022/0015798 A1 1/2022 Marchand et al.
 2022/0022898 A1 1/2022 Cox et al.
 2022/0033888 A1 2/2022 Schnall-Levin et al.
 2022/0039815 A1 2/2022 Thress et al.
 2022/0125451 A1 4/2022 Hauser
 2022/0142638 A1 5/2022 Enright et al.
 2022/0151647 A1 5/2022 Dolendo et al.
 2022/0152355 A1 5/2022 Dolendo et al.
 2022/0160381 A1 5/2022 Hauser
 2022/0160382 A1 5/2022 Hauser
 2022/0160383 A1 5/2022 Hauser
 2022/0211400 A1 7/2022 Cox et al.
 2022/0211992 A1 7/2022 Merritt et al.
 2022/0240959 A1 8/2022 Quick
 2022/0296797 A1 9/2022 Chawla
 2022/0346800 A1 11/2022 Merritt et al.
 2022/0346813 A1 11/2022 Quick
 2022/0346814 A1 11/2022 Quick
 2022/0347455 A1 11/2022 Merritt et al.
 2022/0362512 A1 11/2022 Quick et al.
 2022/0370761 A1 11/2022 Chou et al.
 2023/0046775 A1 2/2023 Quick
 2023/0047682 A1 2/2023 Deaton et al.
 2023/0052964 A1 2/2023 Singh et al.
 2023/0059721 A1 2/2023 Chou et al.
 2023/0062809 A1 3/2023 Merritt et al.
 2023/0070120 A1 3/2023 Cox et al.
 2023/0122587 A1 4/2023 Chou et al.
 2023/0200970 A1 6/2023 Merritt et al.
 2023/0218310 A1 7/2023 Scheinblum et al.
 2023/0218313 A1 7/2023 Rosenbluth et al.
 2023/0218383 A1 7/2023 Merritt et al.
 2023/0233311 A1 7/2023 Merritt et al.
 2023/0240705 A1 8/2023 Rosenbluth et al.
 2023/0240706 A1 8/2023 Rosenbluth et al.
 2023/0241302 A1 8/2023 Merritt et al.
 2023/0248380 A1 8/2023 Long et al.
 2023/0248502 A1 8/2023 Buck et al.
 2023/0270991 A1 8/2023 Merritt et al.
 2023/0310137 A1 10/2023 Merritt et al.
 2023/0310138 A1 10/2023 Merritt et al.
 2023/0310751 A1 10/2023 Merritt et al.
 2023/0320834 A1 10/2023 Merritt et al.
 2023/0329734 A1 10/2023 Marchand et al.
 2023/0338130 A1 10/2023 Merritt et al.
 2023/0338131 A1 10/2023 Merritt et al.
 2023/0355256 A1 11/2023 Dinh
 2023/0355259 A1 11/2023 Marchand et al.
 2023/0355938 A1 11/2023 Merritt et al.
 2023/0363776 A1 11/2023 Quick
 2023/0363883 A1 11/2023 Merritt et al.
 2023/0389932 A1 12/2023 Ozenne et al.
 2023/0390045 A1 12/2023 Merritt et al.
 2024/0058113 A1 2/2024 Strauss et al.
 2024/0074771 A1 3/2024 Quick et al.
 2024/0082540 A1 3/2024 Brodt et al.
 2024/0157041 A1 5/2024 Zikry et al.
 2024/0198072 A1 6/2024 Merritt et al.

FOREIGN PATENT DOCUMENTS

CN 103764049 4/2014
 CN 103932756 7/2014
 CN 104068910 10/2014
 CN 106178227 12/2016
 CN 108348319 7/2018
 CN 110652645 1/2020
 CN 111281482 6/2020
 DE 102017004383 7/2018
 EP 1254634 11/2002
 EP 2394680 12/2011
 EP 1867290 2/2013

EP 2540328 10/2013
 EP 2942624 11/2015
 EP 2231256 5/2018
 EP 3583972 12/2019
 EP 3589348 1/2020
 EP 3620204 3/2020
 EP 3013404 4/2020
 EP 4137070 2/2023
 GB 1588072 4/1981
 GB 2498349 7/2013
 JP H6190049 7/1994
 JP H07323090 A 12/1995
 JP 2001522631 5/1999
 JP 2004097807 4/2004
 JP 2005-095242 6/2005
 JP 2005230132 9/2005
 JP 2005323702 11/2005
 JP 2006094876 4/2006
 JP 2007-222658 9/2007
 JP 2011526820 1/2010
 JP 05694718 4/2015
 WO WO1997017889 5/1997
 WO WO9833443 8/1998
 WO WO9838920 9/1998
 WO WO9839053 9/1998
 WO WO9851237 11/1998
 WO WO1999044542 9/1999
 WO WO0032118 6/2000
 WO WO2000053120 9/2000
 WO WO0202162 1/2002
 WO WO03015840 2/2003
 WO WO2004018916 3/2004
 WO WO2004093696 11/2004
 WO WO2005046736 5/2005
 WO WO2006029270 3/2006
 WO WO2006110186 10/2006
 WO WO2006124307 11/2006
 WO WO2007092820 8/2007
 WO WO2009082513 7/2009
 WO WO2009086482 7/2009
 WO WO2009155571 12/2009
 WO WO2010002549 1/2010
 WO WO2010010545 1/2010
 WO WO2010023671 3/2010
 WO WO2010049121 5/2010
 WO WO2010102307 9/2010
 WO WO2011032712 3/2011
 WO WO2011054531 5/2011
 WO WO2011073176 6/2011
 WO WO2012009675 1/2012
 WO WO2012011097 1/2012
 WO WO2012049652 4/2012
 WO WO2012065748 5/2012
 WO WO2012114633 8/2012
 WO WO2012120490 9/2012
 WO WO2012162437 11/2012
 WO WO2014047650 3/2014
 WO WO2014081892 5/2014
 WO WO2015006782 1/2015
 WO WO2015061365 4/2015
 WO WO2015121424 8/2015
 WO WO2015179329 11/2015
 WO WO2015189354 12/2015
 WO WO2015191646 12/2015
 WO WO2016014955 1/2016
 WO WO2017024258 2/2017
 WO WO2017058280 4/2017
 WO WO2017070702 4/2017
 WO WO2017106877 6/2017
 WO WO2017189535 11/2017
 WO WO2017189550 11/2017
 WO WO2017189591 11/2017
 WO WO2017189615 11/2017
 WO WO2017210487 12/2017
 WO WO2018049317 3/2018
 WO WO2018065092 4/2018
 WO WO2018080590 5/2018
 WO WO2018148174 8/2018
 WO WO2019010318 1/2019

(56)

References Cited

FOREIGN PATENT DOCUMENTS

WO	WO2019050765	3/2019
WO	WO2019064306	4/2019
WO	WO2019075444	4/2019
WO	WO2019094456	5/2019
WO	WO2019173475	9/2019
WO	WO2019222117	11/2019
WO	WO2019246240	12/2019
WO	WO2020036809	2/2020
WO	WO2021067134	4/2021
WO	WO2021076954	4/2021
WO	WO2021127202	6/2021
WO	WO2021248042	12/2021
WO	WO2022032173	2/2022
WO	WO2022103848	5/2022
WO	WO2022109021	5/2022
WO	WO2022109034	5/2022
WO	WO2023069874	4/2023
WO	WO2023137341	7/2023
WO	WO2023147353	8/2023
WO	WO2023154612	8/2023
WO	WO2023192925	10/2023
WO	WO2023215779	11/2023
WO	WO2024103036	5/2024

OTHER PUBLICATIONS

Gupta, S. et al., "Acute Pulmonary Embolism Advances in Treatment", JAPI, Association of Physicians India, Mar. 2008, vol. 56, 185-191.

International Search Report and Written Opinion for International App. No. PCT/US13/61470, mailed Jan. 17, 2014, 7 pages.

International Search Report and Written Opinion for International App. No. PCT/US2014/046567, mailed Nov. 3, 2014, 13 pages.

International Search Report and Written Opinion for International App. No. PCT/US2014/061645, mailed Jan. 23, 2015, 15 pages.

International Search Report for International App. No. PCT/US13/71101, mailed Mar. 31, 2014, 4 pages.

Konstantinides, S. et al., "Pulmonary embolism hotline 2012—Recent and expected trials", *Thrombosis and Haemostasis*, Jan. 9, 2013:33; 43-50.

Konstantinides, S. et al., "Pulmonary embolism: risk assessment and management", *European Society of Cardiology; European Heart Journal*, Sep. 7, 2012:33, 3014-3022.

Kucher, N. et al., "Percutaneous Catheter Thrombectomy Device for Acute Pulmonary Embolism: In Vitro and in Vivo Testing", *Circulation*, Sep. 2005:112:e28-e32.

Kucher, N., "Catheter Interventions in Massive Pulmonary Embolism", *Cardiology Rounds*, Mar. 2006 vol. 10, Issue 3, 6 pages.

Kucher, N. et al., "Management of Massive Pulmonary Embolism", *Radiology*, Sep. 2005:236:3 852-858.

Kucher, N. et al., "Randomized, Controlled Trial of Ultrasound-Assisted Catheter-Directed Thrombolysis for Acute Intermediate-Risk Pulmonary Embolism." *Circulation*, 2014, 129, p. 9 pages.

Kuo, W. et al., "Catheter-directed Therapy for the Treatment of Massive Pulmonary Embolism: Systematic Review and Meta-analysis of Modern Techniques", *Journal of Vascular and Interventional Radiology*, Nov. 2009:20:1431-1440.

Kuo, W. et al., "Catheter-Directed Embolectomy, Fragmentation, and Thrombolysis for the Treatment of Massive Pulmonary Embolism After Failure of Systemic Thrombolysis", *American College of CHEST Physicians* 2008: 134:250-254.

Kuo, W. MD, "Endovascular Therapy for Acute Pulmonary Embolism", *Continuing Medical Education Society of Interventional Radiology ("CME")*; *Journal of Vascular and Interventional Radiology*, Feb. 2012: 23:167-179.

Lee, L. et al., "Massive pulmonary embolism: review of management strategies with a focus on catheter-based techniques", *Expert Rev. Cardiovasc. Ther.* 8(6), 863-873 (2010).

Liu, S. et al., "Massive Pulmonary Embolism: Treatment with the Rotarex Thrombectomy System" *Cardiovascular Interventional Radiology*; 2011: 34:106-113.

Muller-Hulsbeck, S. et al. "Mechanical Thrombectomy of Major and Massive Pulmonary Embolism with Use of the Amplatz Thrombectomy Device", *Investigative Radiology*, Jun. 2001:36:6:317-322.

Reekers, J. et al., "Mechanical Thrombectomy for Early Treatment of Massive Pulmonary Embolism", *Cardiovascular and Interventional Radiology*, 2003: 26:246-250.

Schmitz-Rode et al., "New Mesh Basket for Percutaneous Removal of Wall-Adherent Thrombi in Dialysis Shunts," *Cardiovasc Intervent Radiol* 16:7-10 1993 4 pgs.

Schmitz-Rode et al., "Temporary Pulmonary Stent Placement as Emergency Treatment of Pulmonary Embolism," *Journal of the American College of Cardiology*, vol. 48, No. 4, 2006 (5 pgs.).

Schmitz-Rode, T. et al., "Massive Pulmonary Embolism: Percutaneous Emergency Treatment by Pigtail Rotation Catheter", *JACC Journal of the American College of Cardiology*, Aug. 2000:36:2:375-380.

Spiotta, A et al., "Evolution of thrombectomy approaches and devices for acute stroke: a technical review." *J NeuroIntervent Surg* 2015, 7, p. 7 pages.

Svilaas, T. et al., "Thrombus Aspiration During Primary Percutaneous Coronary Intervention." *The New England Journal of Medicine*, 2008, vol. 358, No. 6, 11 pages.

Tapson, V., "Acute Pulmonary Embolism", *The New England Journal of Medicine*, Mar. 6, 2008:358:2037-52.

The Penumbra Pivotal Stroke Trial Investigators, "The Penumbra Pivotal Stroke Trial: Safety and Effectiveness of a New Generation of Mechanical Devices for Clot Removal in Intracranial Large Vessel Occlusive Disease." *Stroke*, 2009, 40: p. 9 pages.

Truong et al., "Mechanical Thrombectomy of Iliocaval Thrombosis Using a Protective Expandable Sheath," *Cardiovasc Intervent Radiol* 27:254-258, 2004, 5 pgs.

Turk et al., "Adapt FAST study: a direct aspiration first pass technique for acute stroke thrombectomy." *J Neurointervent Surg*, vol. 6, 2014, 6 pages.

Uflacker, R., "Interventional Therapy for Pulmonary Embolism", *Journal of Vascular and Interventional Radiology*, Feb. 2001: 12:147-164.

Verma, R., MD et al. "Evaluation of a Newly Developed Percutaneous Thrombectomy Basket Device in Sheep With Central Pulmonary Embolisms", *Investigative Radiology*, Oct. 2006, 41, 729-734.

International Search Report and Written Opinion for International App. No. PCT/US2015/034987 filed Jun. 9, 2015, Applicant: Inceptus Medical, LLC, Date of Mailing: Sep. 17, 2015, 12 pages.

International Search Report and Written Opinion for International App. No. PCT/US2016/067628 filed Dec. 19, 2016, Applicant: Inari Medical, Inc., Date of Mailing: Apr. 10, 2017, 11 pages.

Goldhaber, S. et al. "Percutaneous Mechanical Thrombectomy for Acute Pulmonary Embolism—A Double-Edged Sword," *American College of CHEST Physicians*, Aug. 2007, 132:2, 363-372.

Goldhaber, S., "Advanced treatment strategies for acute pulmonary embolism, including thrombolysis and embolectomy," *Journal of Thrombosis and Haemostasis*, 2009: 7 (Suppl. 1): 322-327.

International Search Report and Written Opinion for International App. No. PCT/US2017/029696, Date of Filing: Apr. 26, 2017, Applicant: Inari Medical, Inc., Date of Mailing: Sep. 15, 2017, 19 pages.

International Search Report and Written Opinion for International App. No. PCT/US2016/058536, Date of Filing: Oct. 24, 2016, Applicant: Inari Medical, Inc., Date of Mailing: Mar. 13, 2017, 14 pages.

International Search Report and Written Opinion for International App. No. PCT/US2018/048786, Date of Filing: Aug. 30, 2018, Applicant: Inari Medical, Inc., Date of Mailing: Dec. 13, 2018, 12 pages.

International Search Report and Written Opinion for International App. No. PCT/US2018/055780, Date of Filing: Oct. 13, 2018, Applicant: Inceptus Medical LLC., Date of Mailing: Jan. 22, 2019, 8 pages.

(56)

References Cited

OTHER PUBLICATIONS

International Search Report and Written Opinion for International App. No. PCT/US2019/045794, Date of Filing: Aug. 8, 2019, Applicant: Inari Medical, Inc., Date of Mailing: Nov. 1, 2019, 17 pages.

International Search Report and Written Opinion for International App. No. PCT/US2020/056067, Date of Filing: Oct. 16, 2020, Applicant: Inari Medical, Inc., Date of Mailing: Jan. 22, 2021, 8 pages.

International Search Report and Written Opinion for International App. No. PCT/US2020/055645, Date of Filing: Dec. 17, 2020, Applicant: Inari Medical, Inc., Date of Mailing: Apr. 14, 2021, 12 pages.

Vorwerk, D. MD, et al., "Use of a Temporary Caval Filter to Assist Percutaneous Iliocaval Thrombectomy: Experimental Results." *SCVIR*, 1995, 4 pages.

Wikipedia; Embolectomy; retrieved from the internet: <https://en.wikipedia.org/wiki/Embolectomy>; 4 pgs.; retrieved/printed: Mar. 24, 2016.

O'Sullivan; Thrombolysis versus thrombectomy in acute deep vein thrombosis; *Interventional Cardiology*; 3(5); pp. 589-596; Oct. 2011.

Capture Vascular Systems; (company website); retrieved from the internet: <http://www.capturevascular.com>; 3 pgs.; retrieved/printed: Mar. 24, 2016.

Edwards Lifesciences; Fogarty® Occlusion Catheters (product brochure); retrieved from the internet: <http://web.archive.org/web/20150228193218/http://www.edwards.com/products/vascular/atraumaticocclusion/pages/occlusioncatheter.aspx; @2011>; 2 pgs.; retrieved/printed: Mar. 24, 2011.

Boston Scientific; Fetch(TM) 2 Aspiration Catheter (product information); retrieved from the internet: <http://www.bostonscientific.com/en-US/products/thrombectomy-systems/fetch2-aspiration-catheter.html>; 2 pgs.; retrieved/printed: Mar. 24, 2016.

Penumbra, Inc.; Indigo® System (product information); retrieved from the internet: <http://www.penumbrainc.com/peripheralpercutaneous-thromboembolectomy/indigo-system>; 7 pgs.; retrieved/printed: Mar. 24, 2016.

Youtube; Merci Retrieval System X Series Animation; uploaded Mar. 16, 2009 (product information); posted on May 7, 2009 by SSMDePAUL, time 1:09, retrieved from the internet: <https://www.youtube.com/watch?v=MGX7deuFkhc>; 3 pgs.; retrieved/printed: Mar. 24, 2016.

Covidien; Solitaire(TM) AS Neurovascular Remodeling Device (product information); retrieved from the internet: <http://www.ev3.net/neuro/intl/remodeling-devices/solitaire-ab.htm; @2015>; 2 pgs.; retrieved/printed: Mar. 24, 2016.

International Search Report and Written Opinion for International App. No. PCT/US21/35965, Date of Filing: Jun. 4, 2021, Applicant: Inari Medical, Inc., Date of Mailing: Sep. 28, 2021, 12 pages.

International Search Report and Written Opinion for International App. No. PCT/US21/45072 Date of Filing: Aug. 6, 2021, Applicant: Inari Medical, Inc., Date of Mailing: Jan. 20, 2022, 10 pages.

International Search Report and Written Opinion for International App. No. PCT/US21/58793; Date of Filing: Nov. 10, 2021, Applicant: Inari Medical, Inc., Date of Mailing: Mar. 16, 2022, 13 pages.

International Search Report and Written Opinion for International App. No. PCT/US21/59718; Date of Filing: Nov. 17, 2021, Applicant: Inari Medical, Inc., Date of Mailing: Mar. 22, 2022, 13 pages.

International Search Report and Written Opinion for International App. No. PCT/US21/59735; Date of Filing: Nov. 17, 2021, Applicant: Inari Medical, Inc., Date of Mailing: Mar. 22, 2022, 11 pages.

International Search Report and Written Opinion for International App. No. PCT/US23/60502; Date of Filing: Jan. 11, 2023, Applicant: Inari Medical, Inc., Date of Mailing: May 25, 2023, 9 pages.

International Search Report and Written Opinion for International App. No. PCT/US23/61256; Date of Filing: Jan. 25, 2023, Applicant: Inari Medical, Inc., Date of Mailing: Jun. 7, 2023, 8 pages.

Gross et al., "Dump the pump: manual aspiration thrombectomy (MAT) with a syringe is technically effective, expeditious, and cost-efficient," *J Neurointervent Surg*, 2018, 4 pages.

English translation of Japanese Office Action mailed Jun. 7, 2023 for Japanese Application No. 2021-507564, 7 pages.

European Office Action received for EP Application No. 16876941.2, Applicant: Inari Medical, Inc, Date of Mailing: Jul. 18, 2023, 6 pages.

International Search Report and Written Opinion for International App. No. PCT/US23/60927; Date of Filing: Jan. 19, 2023, Applicant: Inari Medical, Inc., Date of Mailing: Jul. 20, 2023, 12 pages.

Extended European Search Report issued for EP Application No. 20877370.5, Date of Mailing: Oct. 17, 2023, 11 pages.

International Search Report and Written Opinion for International App. No. PCT/US23/65128; Date of Filing: Mar. 30, 2023, Applicant: Inari Medical, Inc., Date of Mailing: Nov. 14, 2023, 14 pages.

International Search Report and Written Opinion for International App. No. PCT/US23/66538; Date of Filing: May 3, 2023, Applicant: Inari Medical, Inc., Date of Mailing: Jan. 4, 2024, 14 pages.

English translation of Japanese Office Action received for JP Application No. 2022-574456, Applicant: Inari Medical, Inc, Date of Mailing: Jan. 23, 2024, 12 pages.

Chinese First Office Action received for CN Application No. 201980067623.1, Applicant: Inari Medical, Inc., Date of Mailing: Jan. 31, 2024, 10 pages.

International Search Report and Written Opinion for International App. No. PCT/US23/73765; Date of Filing: Sep. 8, 2023, Applicant: Inari Medical, Inc., Date of Mailing: Feb. 28, 2024, 7 pages.

International Search Report and Written Opinion for International App. No. PCT/US23/69892; Date of Filing: Jul. 10, 2023, Applicant: Inari Medical, Inc., Date of Mailing: Feb. 29, 2024, 12 pages.

English translation of Japanese Office Action mailed Jan. 19, 2024 for Japanese Application No. 2022-160947, 8 pages.

International Search Report and Written Opinion for International App. No. PCT/US2024/010875; Applicant: Inari Medical, Inc., Date of Mailing: Apr. 26, 2024, 15 pages.

International Search Report and Written Opinion for International App. No. PCT/US2023/079428; Applicant: Inari Medical, Inc., Date of Mailing: May 29, 2024, 18 pages.

Extended European Search Report for European Application No. 21818772.2, Applicant: Inari Medical, Inc., Date of Mailing: May 10, 9 pages.

* cited by examiner

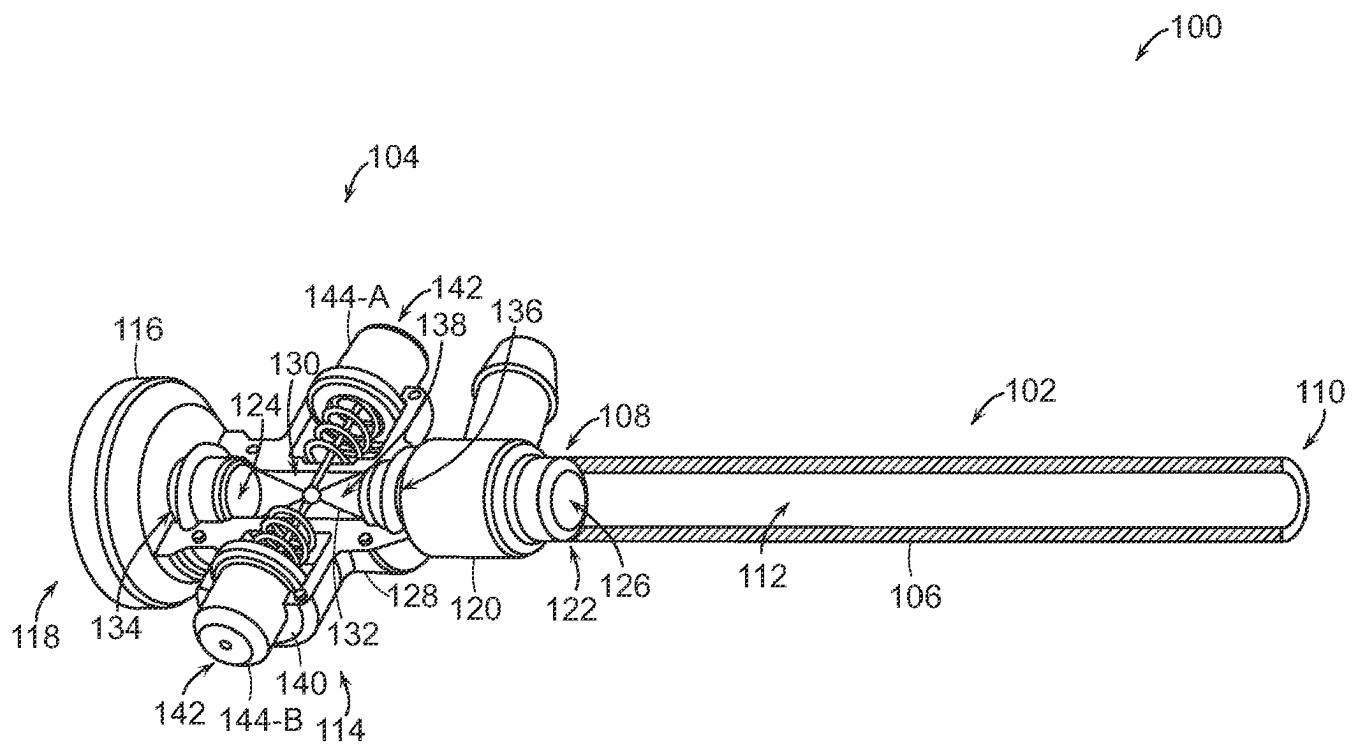

FIG. 1

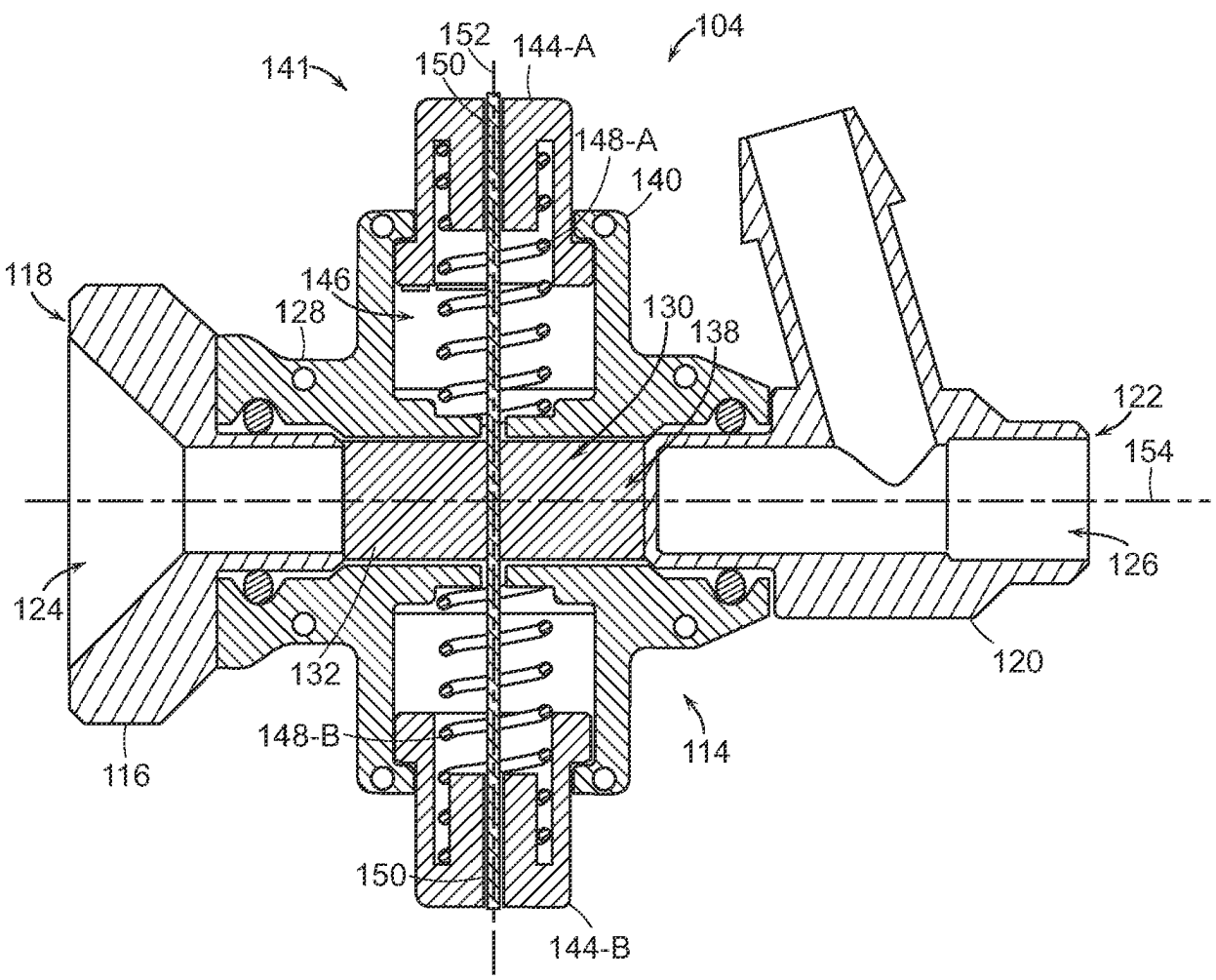

FIG. 2

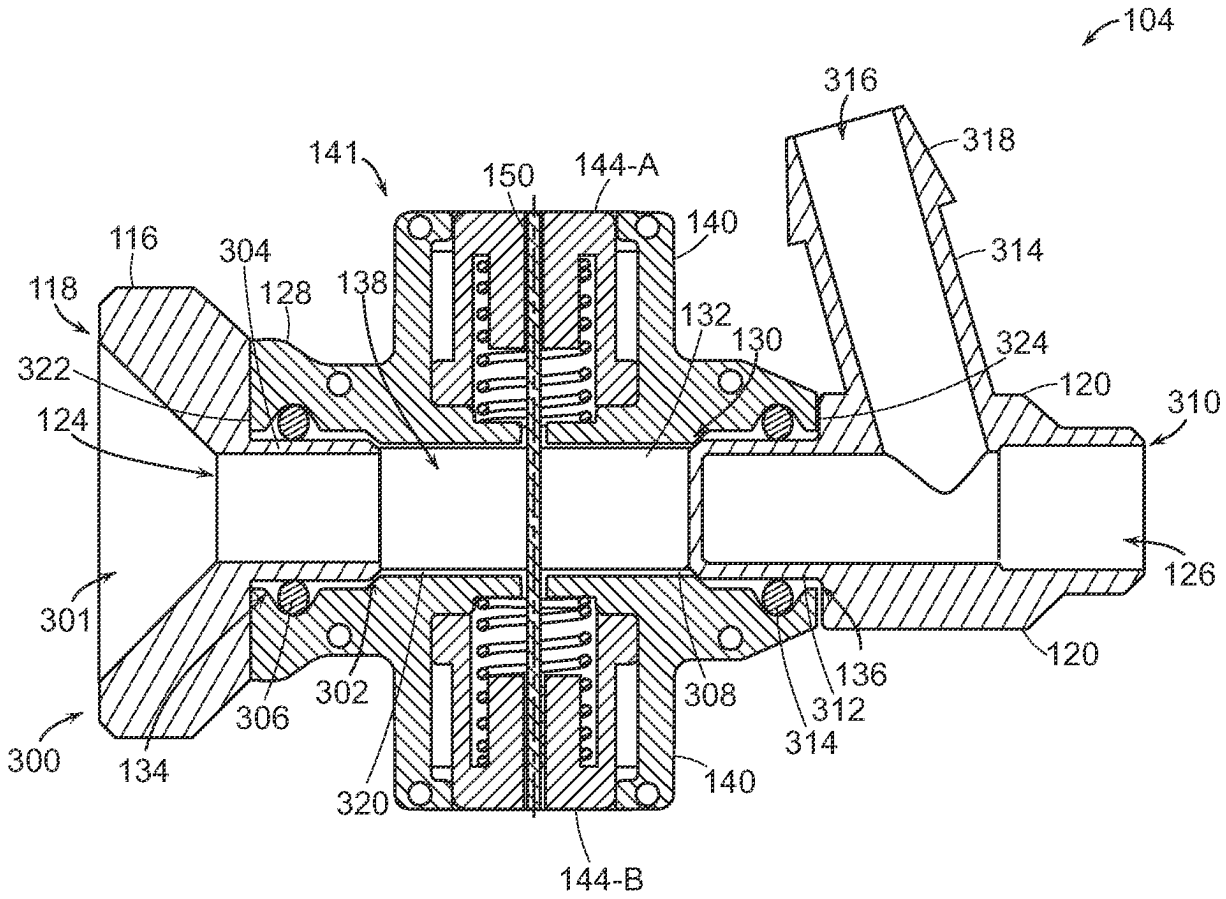

FIG. 3

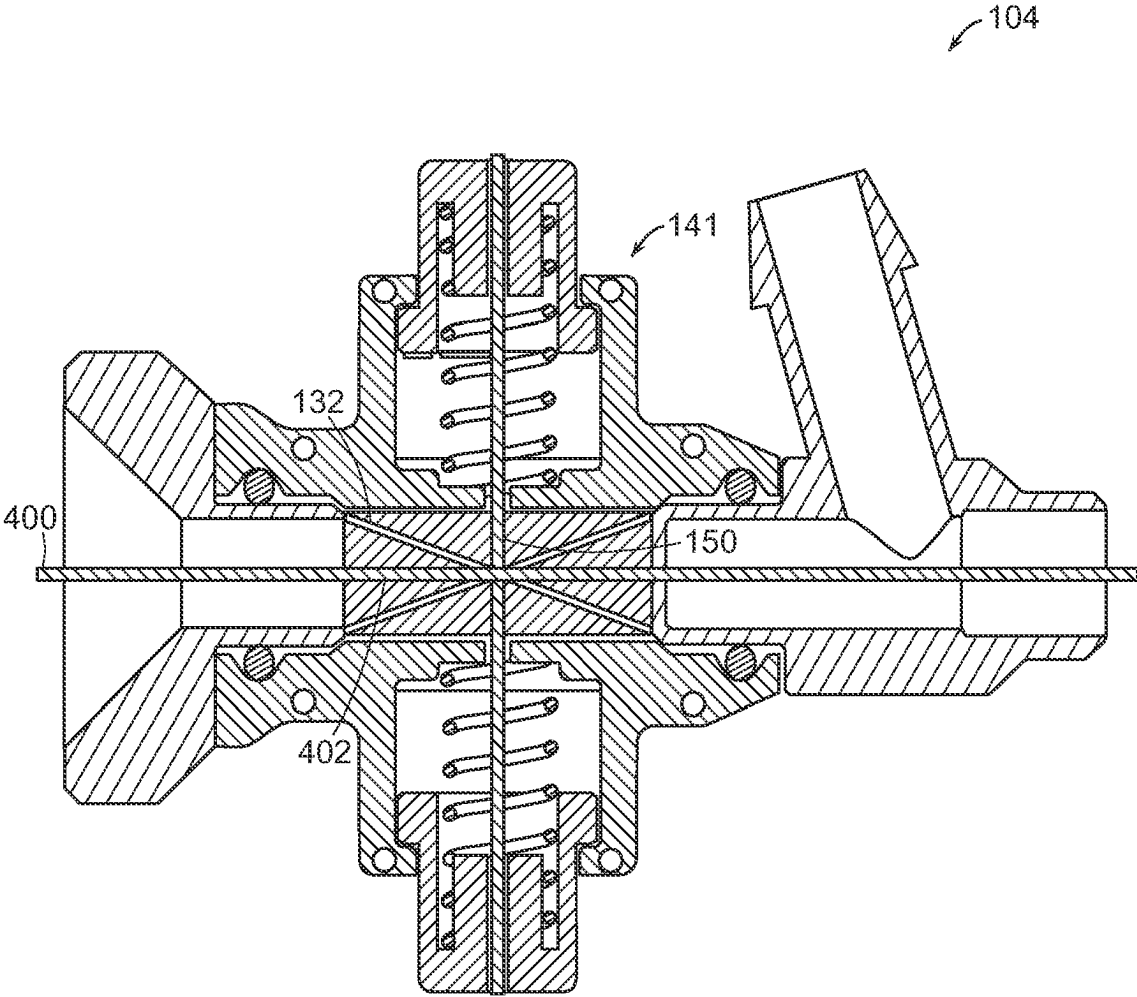

FIG. 4

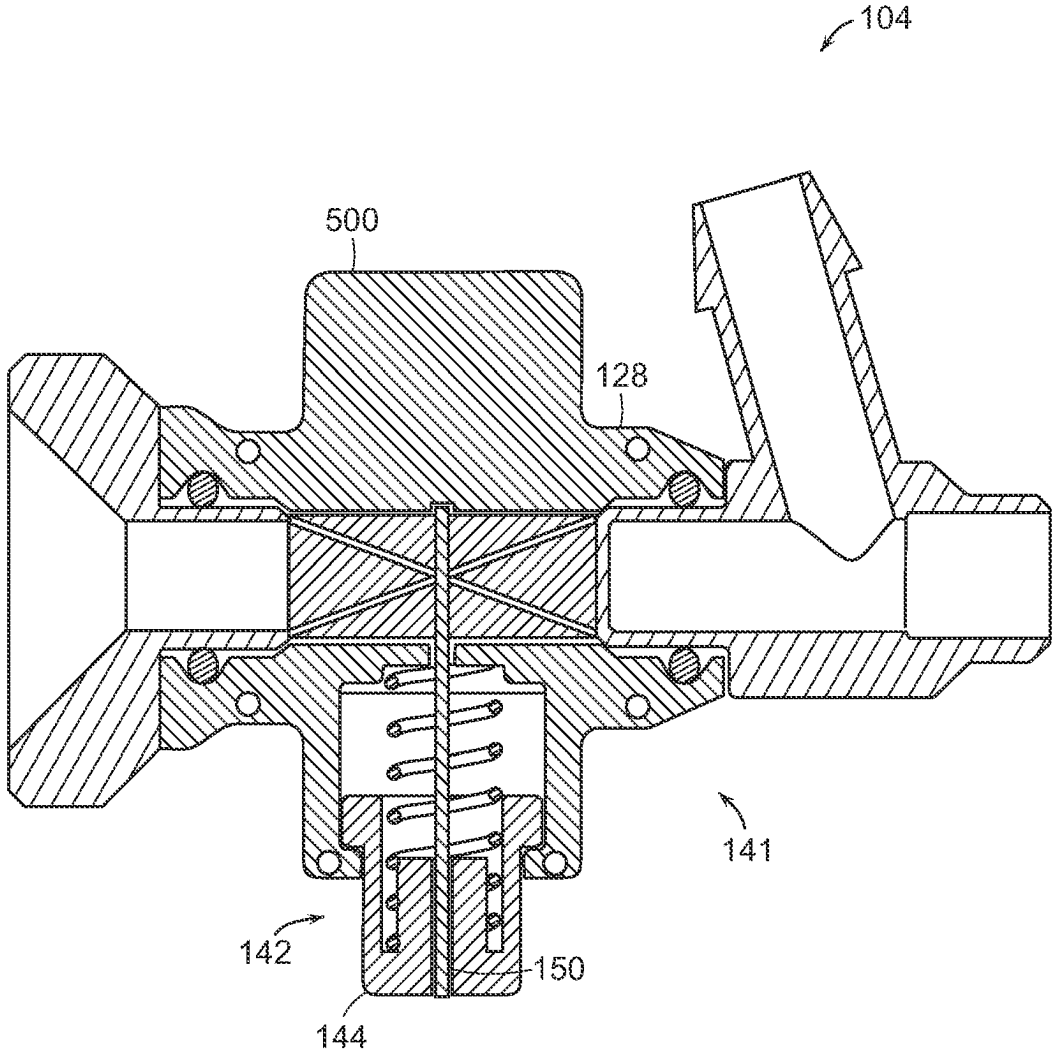

FIG. 5

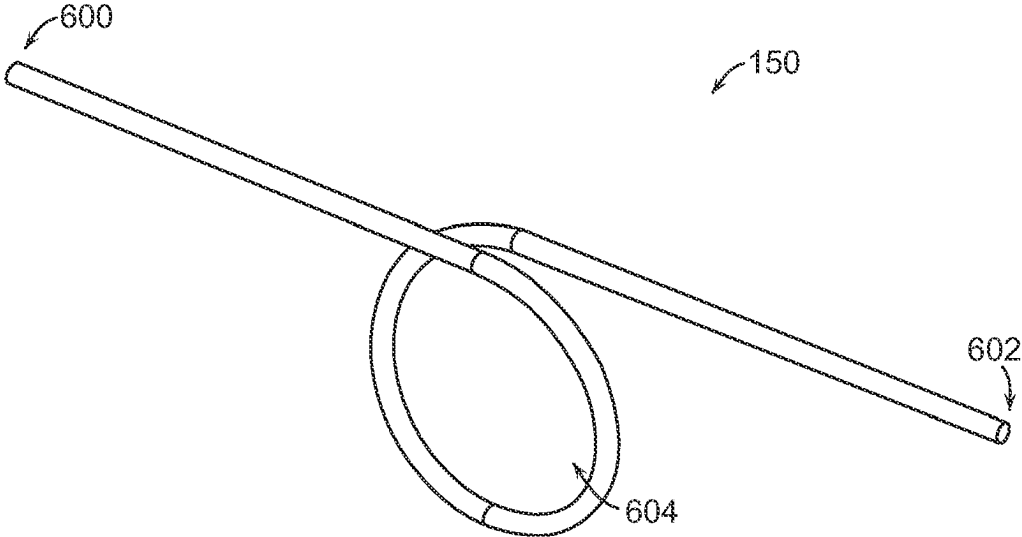

FIG. 6

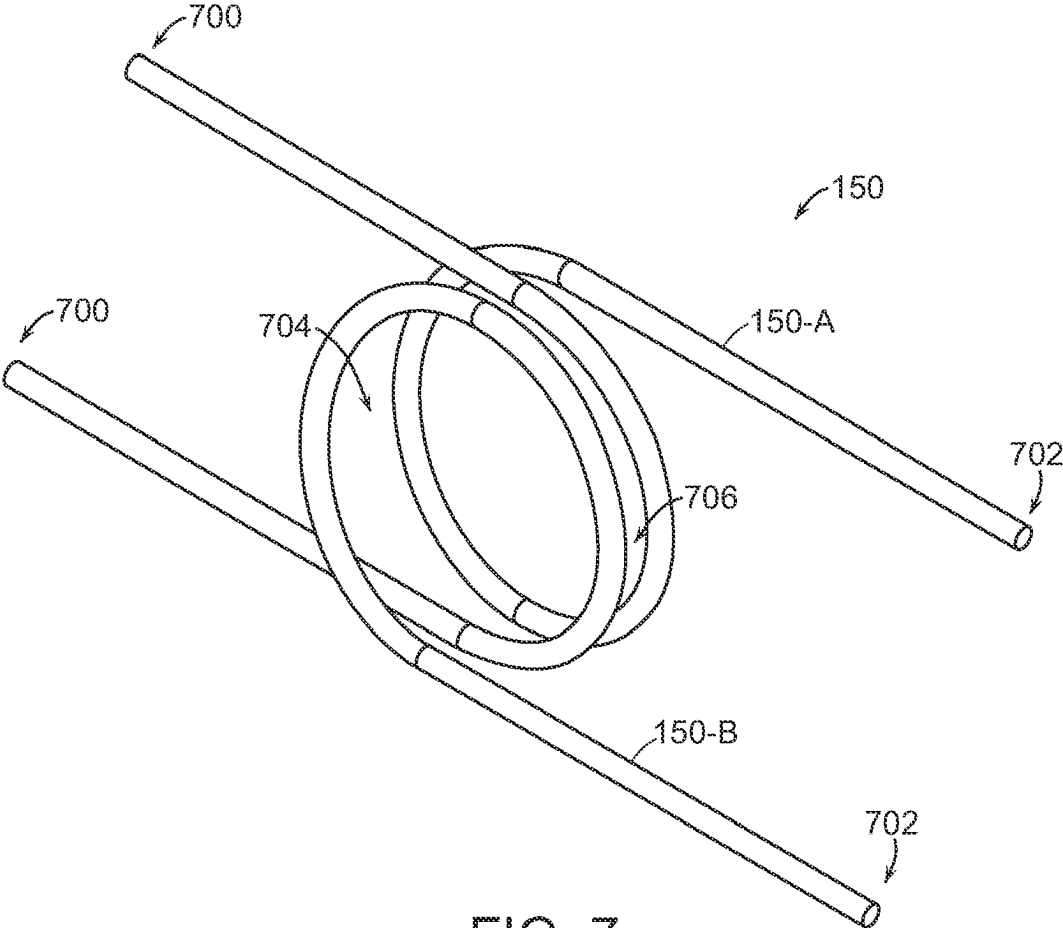

FIG. 7

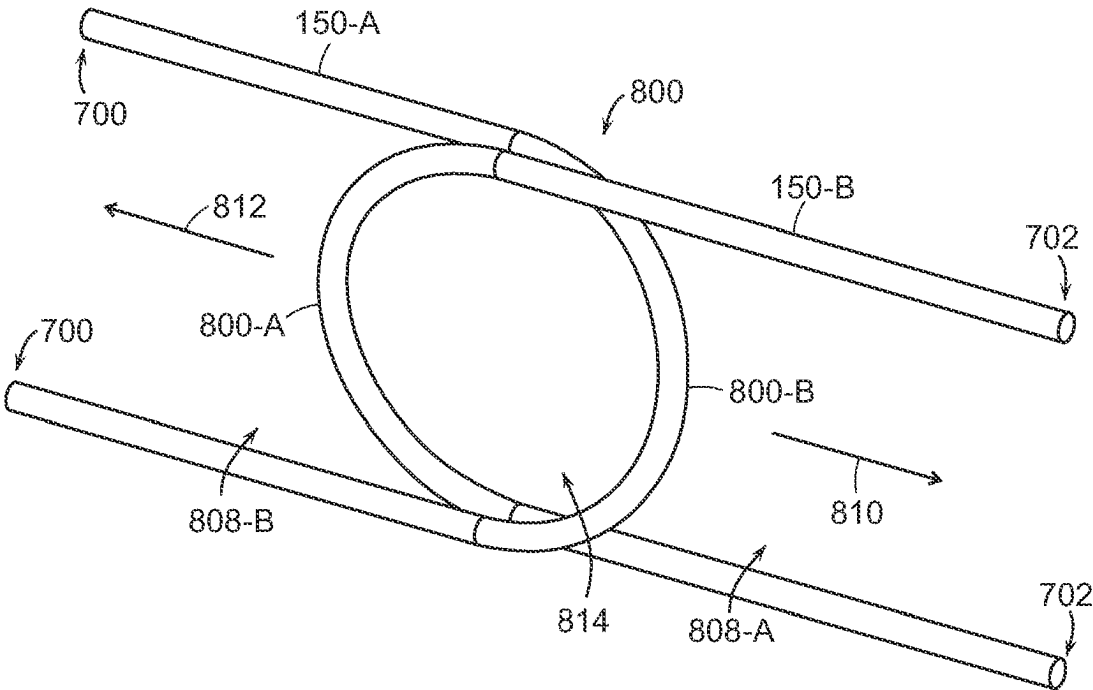

FIG. 8

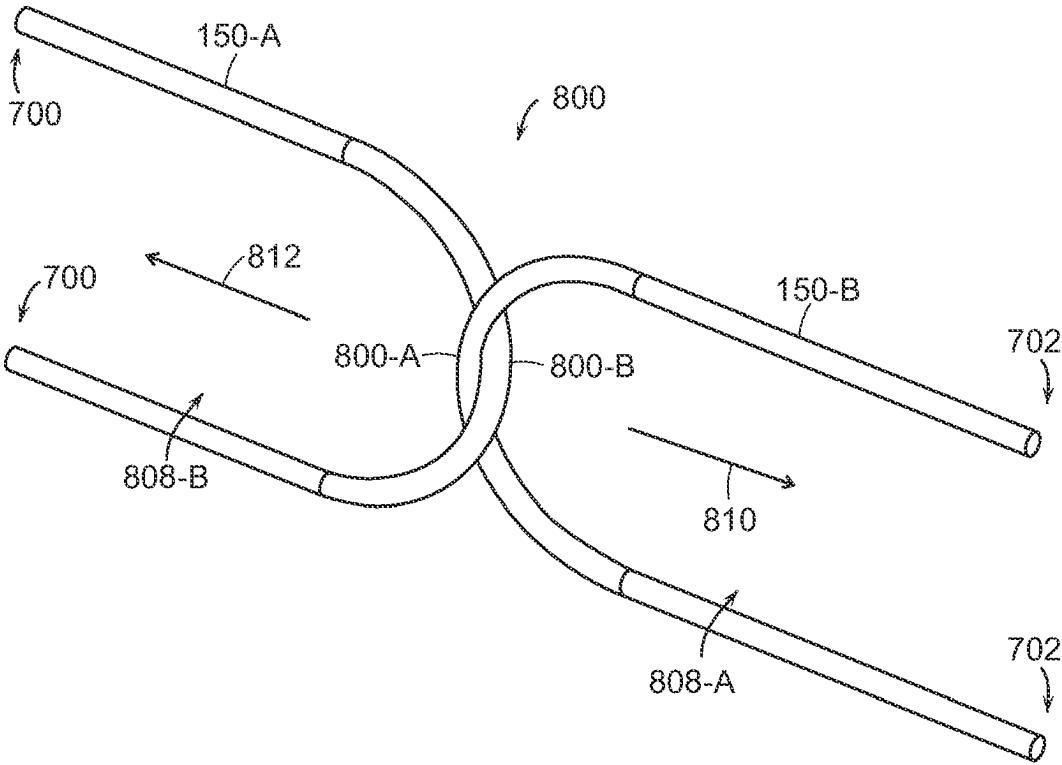

FIG. 9

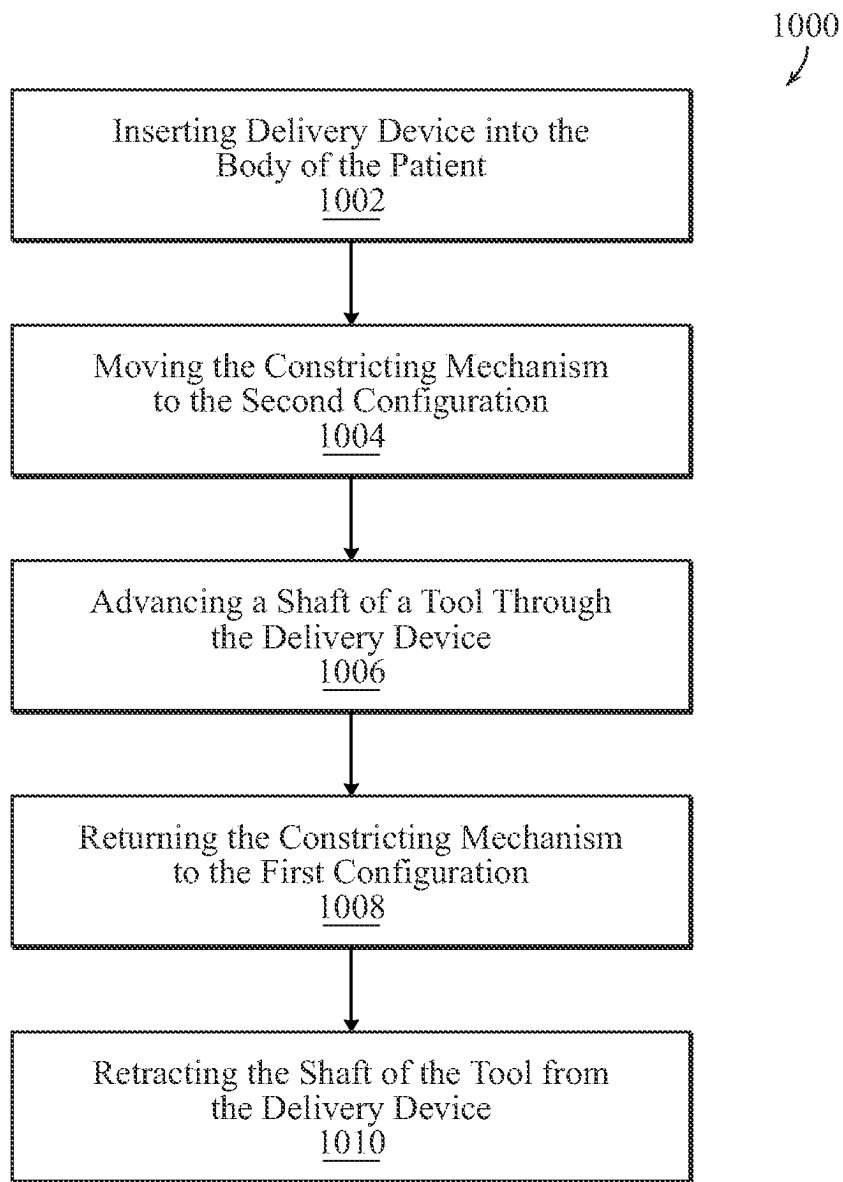

FIG. 10

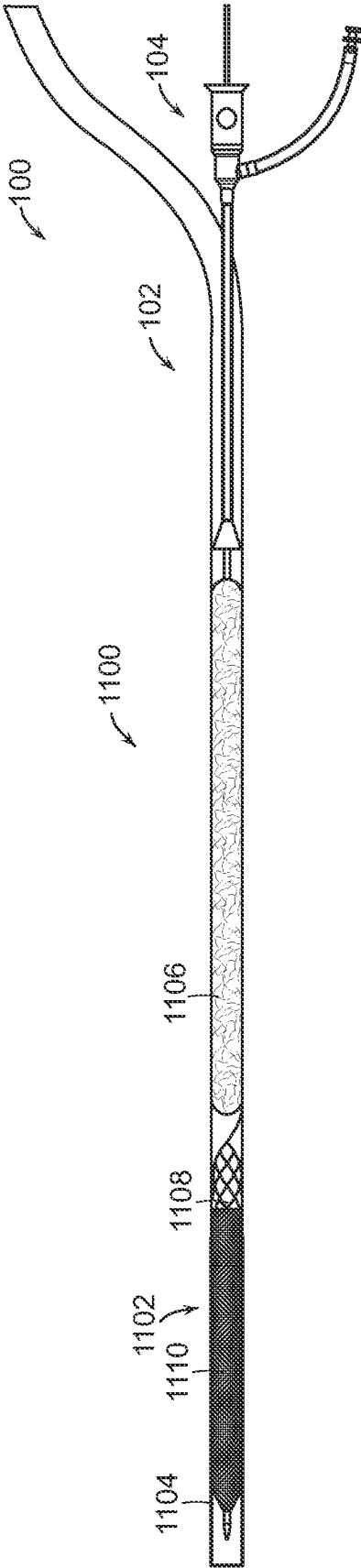

FIG. 11

HEMOSTASIS VALVES AND METHODS OF USE

CROSS-REFERENCE TO RELATED APPLICATIONS

This application is a continuation of U.S. patent application Ser. No. 18/515,079, filed on Nov. 20, 2023, titled “HEMOSTASIS VALVES AND METHODS OF USE,” which is a continuation of U.S. patent application Ser. No. 17/226,318, filed on Apr. 9, 2021, issued as U.S. Pat. No. 11,844,921, and titled “HEMOSTASIS VALVES AND METHODS OF USE,” which is a continuation of U.S. patent application Ser. No. 16/117,519, filed on Aug. 30, 2018, now issued as U.S. Pat. No. 11,000,682, and titled “HEMOSTASIS VALVES AND METHODS OF USE,” which claims the benefit of U.S. Provisional Patent Application No. 62/554,931, filed on Sep. 6, 2017, and titled “HEMOSTASIS VALVES AND METHODS OF USE,” each of which is incorporated by reference herein in its entirety.

BACKGROUND

During a surgical procedure, a portion of a patient’s body (e.g., vasculature) is accessed to allow for performance of a desired intervention or treatment. During such surgical procedures, it is desired to minimize patient blood loss, prevent delivery of air into the vasculature, and to maintain the sterility of the accessed portions or sites of the patient’s body so as to prevent issues such as infection. Further, the desire for improved patient outcomes has led to the development of hemostasis valves that facilitate minimally invasive surgery.

In minimally invasive surgery, small incisions are created through a blood vessel which one or several catheters are inserted. Each of these one or several catheters can define a lumen extending longitudinally through that catheter. These catheters are moved to a position proximate to tissue, nerves, or other body structures targeted by the surgery, and then tools for performing the procedure are inserted through the lumens of some or all of these catheters.

To minimize blood loss, prevent delivery of air into the vasculature, and to facilitate maintenance of sterility within the patient’s body (e.g., blood vessel), these catheters are equipped with hemostasis valves. These valves seal or selectively seal the lumens of the catheters. In many instances, these valves can seal the lumen of the catheter when a tool extends through the catheter, and specifically through the valve. Additionally the valves can seal the lumen when a tool is removed or does not extend through the catheter.

While such traditional hemostasis valves are greatly beneficial for intravascular access, they have some drawbacks. For example, some valves may not seal adequately for all interventional applications or tools, and/or the operation of some valves may be complicated for operator use. The drawbacks of such valve designs may in turn increase the complexity of any surgery performed therewith and/or reduce patient safety (e.g., bleeding, infection, and/or other detrimental complications). Accordingly, new and improved hemostasis valves and methods of use are desired.

SUMMARY

The following relates to valves, medical systems incorporating valves, and methods of using the same. The valve can include a tubular member that can be constricted,

collapsed, and/or sealed by one or several tensioning mechanisms. The tensioning mechanism can include at least one filament that extends around at least a portion of the tubular member. The filament can interact with the tubular member to constrict, collapse, and/or seal the tubular member via manipulation of the tensioning mechanism(s). A tool can be inserted through the valve to gain access to a patient’s body and specifically to gain access to a blood vessel. Through the use of the tensioning mechanism and filament to constrict, collapse, and/or seal the tubular member, the valve can seal around a wide range of tool sizes and shapes, as well as multiple tools of differing sizes simultaneously. Additionally, such a valve creates a robust seal that maintains its seal when a vacuum is applied such as occurs during aspiration.

Aspects of the present disclosure relate to a hemostatic valve for sealing a medical device. The hemostatic valve includes an elongate member having a first end, a second end, and a central lumen extending therebetween. In some embodiments, the elongate member is pliable. The hemostatic valve can include a reinforcement structure extending along at least a portion of the elongate member, such that the reinforcement structure is coupled to the elongate member. The hemostatic valve includes an active tensioning mechanism coupled to the elongate member. In some embodiments, the tensioning mechanism is moveable between a first configuration in which the central lumen is constricted and sealed and a second configuration in which the central lumen is open. Optionally, the valve may be manually adjusted by the user to intermediate positions between fully open and fully closed. Additionally, an instrument (e.g. catheter) may provide an intermediate position where the valve creates hemostasis without user adjustment.

In some embodiments, the elongate member can be a compliant polymer tube. In some embodiments, the tensioning mechanism can include at least one filament extending at least partially around the elongate member. In some embodiments, the reinforcement structure is positioned between the at least one filament and the elongate member. In some embodiments, the reinforcement structure can be a braided mesh. In some embodiments, the reinforcement structure is coupled to the elongate member at a position proximate to the first end of the elongate member and at a position proximate to the second end of the elongate member. In some embodiments, the reinforcement structure is not coupled to the elongate member at a position between the first end of the elongate member and the second end of the elongate member. In some embodiments, the central portion of the compliant polymer tube that is constrained or collapsed by the tensioning mechanism, and at least one filament, is not coupled to the reinforcement structure.

In some embodiments, the tensioning mechanism can include an actuator coupled to the at least one filament. In some embodiments there are two tensioning mechanisms coupled to the at least one filament that operate in opposite directions. In some embodiments the two tensioning mechanisms are attached to the same filament. In some embodiments the two tensioning mechanisms are attached to opposing filaments. In some embodiments, the actuator can be moveable to control movement of the at least one filament from a first position in which the central lumen is constricted and sealed to a second position in which the central lumen is open. In some embodiments, the at least one filament is in the first position when the tensioning mechanism is in the first configuration. In some embodiments, the actuator is biased towards the first position. In some embodiments, the actuator is biased toward the second position. In some embodiments, the actuator can be a manual actuator.

3

In some embodiments, the at least one filament forms a loop around the elongate member. In some embodiments, the at least one filament forms a bight around a portion of the elongate member. In some embodiments, the at least one filament can include a first filament and a second filament. In some embodiments, each of the first filament and the second filament are coupled to the same actuator. In some embodiments, each of the first filament and the second filament are coupled to different actuators. In some embodiments, the first filament and the second filament are moveable from the first position to the second position. In some embodiments, each of the first filament and the second filament form a loop around the elongate member. In some embodiments, the first filament forms a first bight around a first portion of the elongate member, and the second filament forms a second bight around a second portion of the elongate member. In some embodiments, the first bight extends through the second bight.

In some embodiments, the hemostatic valve can include a shell defining a first aperture and a second aperture. In some embodiments, the elongate member extends from the first aperture to the second aperture and fluidly couples the first aperture and the second aperture. In some embodiments, the tensioning mechanism is self-adjustable to seal around tools of different sizes extending through the hemostatic valve. In some embodiments, the central lumen can comprise a single lumen, and in some embodiments, the central lumen can comprise a plurality of lumens.

One aspect of the present disclosure relates to a delivery system for intravascular access of a blood vessel within a patient's body. The delivery system includes a catheter having a first end, a second end, and a catheter lumen extending therebetween and a hemostatic valve coupled to the first end of the catheter. The hemostatic valve includes a tubular member having a first end, a second end, and a central lumen extending therebetween. In some embodiments, the central lumen of the tubular member is fluidly coupled with the catheter lumen. The hemostatic valve includes an active tensioning mechanism coupled to the tubular member, the tensioning mechanism can be moveable between a first configuration in which the tensioning mechanism constricts on the central lumen and the central lumen is sealed and a second configuration in which the central lumen is open.

In some embodiments, the hemostatic valve further includes a reinforcement structure extending along at least a portion of the tubular member. In some embodiments, the reinforcement structure is located between the tensioning mechanism and the tubular member. In some embodiments, the reinforcement structure can be a braided mesh. In some embodiments, the reinforcement structure is coupled to the tubular member at a position proximate to the first end of the tubular member and at a position proximate to the second end of the tubular member. In some embodiments, the reinforcement structure is adhered to the tubular member at the first end of the tubular member and at the second end of the tubular member. In some embodiments, the reinforcement structure is uncoupled to the tubular member between the first end of the tubular member and the second end of the tubular member.

In some embodiments, the tensioning mechanism can include at least one filament extending at least partially around the tubular member. In some embodiments, the tensioning mechanism can include an actuator coupled to the at least one filament. In some embodiments, moving the tensioning mechanism from the first configuration to the second configuration can include moving the actuator and

4

the thereto coupled at least one filament from a first position to a second position. In some embodiments, the filament constricts and seals the central lumen of the tubular member when the filament is in the first position.

In some embodiments, the actuator can be a manual actuator. In some embodiments, the actuator can include a pair of opposing and depressable buttons, which buttons can be biased towards an undepressed position. In some embodiments, the central lumen is sealed when the buttons are in the undepressed position. In some embodiments, the filament can be a monofilament. In some embodiments, the filament can be at least one of: a polymer filament; or a metallic filament. In some embodiments, the catheter can include a thrombus extraction device.

One aspect of the present disclosure relates to a method of sealing a delivery device accessing a blood vessel of a patient. The method includes inserting the delivery device including a catheter and a hemostatic valve into the blood vessel of the patient. In some embodiments, the catheter can have a first end, a second end, and a catheter lumen extending therethrough. In some embodiments, the hemostatic valve can be coupled to the first end and can have a tubular member defining a central lumen fluidly coupled with the catheter lumen and a tensioning mechanism coupled with the tubular member. In some embodiments, the tensioning mechanism collapses and seals the central lumen in a first configuration and thereby seals access to the blood vessel. The method can include moving the tensioning mechanism of the hemostatic valve to a second configuration. In some embodiments, the central lumen is open and access to the blood vessel is unsealed when the tensioning mechanism is in the second configuration. The method can include advancing a shaft of a tool through the delivery device until a first end of the tool reaches a desired position within the blood vessel of the patient and a portion of the shaft is positioned within the central lumen of the tubular member. The method can include returning the tensioning mechanism of the hemostatic valve to the first configuration such that the tubular member collapses on the shaft of the tool and seals around the shaft of the tool.

In some embodiments, the method includes retracting the shaft of the tool from the delivery device. In some embodiments, the tensioning mechanism is maintained in the first configuration during and after the retracting of the shaft of the tool from the delivery device. In some embodiments, the tensioning mechanism is moved to the second configuration during the retracting of the shaft of the tool from the delivery device, and the tensioning mechanism is returned to the first configuration after the shaft of the tool is retracted from the delivery device.

In some embodiments, the tensioning mechanism can include at least one filament extending at least partially around the tubular member. In some embodiments, the at least one filament collapses the tubular member when the tensioning mechanism is in the first configuration. In some embodiments, the at least one filament circumferentially constricts the tubular member to collapse the tubular member when the tensioning mechanism is in the first configuration. In some embodiments, the hemostatic valve can include a reinforcement structure located between the at least one filament and the tubular member.

In some embodiments, the at least one filament forms a loop around the elongate member, and moving the tensioning mechanism from the second configuration to the first configuration reduces a size of the loop to thereby constrict the tubular member within the loop. In some embodiments, the filament forms at least one bight around a portion of the

5

elongate member. In some embodiments, the filament can include a first filament and a second filament. In some embodiments, the at least one bight can include a first bight oriented in a first direction and formed by the first filament and a second bight oriented in a second direction and formed by the second filament. In some embodiments, the first and second bights overlap to encircle a portion of the tubular member within a constricting area.

In some embodiments, moving the tensioning mechanism from the second configuration to the first configuration can include moving the first bight in the first direction and the second bight in the direction to reduce the size of the constricting area and collapse and seal the central lumen of the tubular member. In some embodiments, the tensioning mechanism can include an actuator. In some embodiments, moving the tensioning mechanism to the second configuration can include manipulating the actuator. In some embodiments, the method includes applying a vacuum to the delivery device and/or delivery system to aspirate material through the catheter. In some embodiments, the central lumen remains sealed during the aspiration. In some embodiments, the tool can include a thrombus extraction device.

BRIEF DESCRIPTION OF THE DRAWINGS

FIG. 1 is a perspective view of one embodiment of a delivery device.

FIG. 2 is a side-section view of one embodiment of a hemostasis valve in a first configuration.

FIG. 3 is a side-section view of one embodiment of the valve in a second configuration.

FIG. 4 is a side-section view of one embodiment of the valve in the first configuration and with a tool extending through the valve.

FIG. 5 is a side-section view of one embodiment of a single-button hemostasis valve in a first configuration.

FIG. 6 is a perspective view of a filament of a valve forming a loop.

FIG. 7 is a perspective view of two filaments of a valve, each of the filaments forming a loop.

FIG. 8 is a perspective view of two overlapping and interlocked bights in an open configuration.

FIG. 9 is a perspective view of two overlapping and interlocked bights in a closed configuration.

FIG. 10 is a flowchart illustrating one embodiment of a method for sealing a valve and/or catheter.

FIG. 11 is a side view of one embodiment of a thrombectomy system including the delivery device.

FIG. 12 is a side-section view of another embodiment of a hemostasis valve having two-piece caps.

DETAILED DESCRIPTION

The present disclosure relates to a valve that can be used as a hemostasis valve. This valve, also referred to herein as a garrote valve can seal with or without a tool extending through the valve. The garrote valve provides convenient, single-handed operation for a wide range of medical devices including catheters, wires, embolectomy systems, or the like. This single-handed operation of the garrote valve allows the user to easily and quickly swap different tools being used through the valve without compromising hemostasis and therefore simplifying the procedure. Combined with single-handed operation, the garrote valve provides robust sealing either with or without a tool extending through the valve. This robust sealing minimizes leakage in

6

applications with a pressure differential on different sides of the valve. This pressure differential can arise, for example, during the application of vacuum aspiration in a procedure. Even under such conditions, as well as under other conditions, the garrote valve maintains seal integrity and prevents leakage in one or both directions.

The garrote valve includes a tubular member. The tubular member is a flexible member that defines a central lumen, which can, in some embodiments, define a single lumen, and in some embodiments, defines a plurality of lumens. In some embodiments, each of the plurality of lumens can comprise the same size and shape, and in some embodiments, some or all of the plurality of lumens can comprise different sizes and shapes. In some embodiments, for example, the plurality of lumens can comprise a lumen sized and/or shaped to receive a guide wire and a lumen sized and/or shaped to receive a tool. The tubular member extends at least partially through a constricting mechanism. The constricting mechanism can be moved from a first configuration to a second configuration, and the constricting mechanism can collapse and/or seal the central lumen of the tubular member when the constricting mechanism is in the first configuration. The constricting mechanism creates the above-discussed robust seal of the tubular member and thus of the valve.

With reference now to FIG. 1, a perspective view of one embodiment of a delivery system 100, also referred to herein as a delivery device 100, is shown. The delivery system 100 can include a catheter 102 and a garrote valve 104, also referred to herein as valve 104. The catheter 102 can comprise a shaft 106, also referred to herein as an elongate sheath 106, having a proximal end 108, also referred to herein as a first end 108, that can connect to the valve 104 and a distal end 110, also referred to herein as a second end 110. The shaft 106 can define a catheter lumen 112 extending from the proximal end 108 of the shaft 106 to the distal end 110 of the shaft 106. The catheter 102 and specifically the shaft 106 can comprise a variety of shapes and sizes and can be made from a variety of materials. In some embodiments, the catheter 102 can be flexible and/or can be made from a biocompatible material. The elongate sheath 106 can have an outer diameter of at least 4 French, at least 6 French, at least 8 French, at least 10 French, at least 12 French, at least 14 French, at least 18 French, at least 20 French, at least 22 French, between 4 French and 30 French, between 8 French and 24 French, between 12 French and 20 French, and/or any other or intermediate size.

The valve 104 can include an outer shell 114. The outer shell 114 can comprise a variety of shapes and sizes and can be made from a variety of materials. In some embodiments, the outer shell 114 can be made from one or several polymers or composites. The outer shell 114 can include features that allow interaction with and/or control of the valve 104 to move the valve 104 between the first configuration and the second configuration.

The outer shell 114 can include a proximal cap 116 located at a proximal end 118 of the outer shell 114 and a distal cap 120 located at a distal end 122 of the shell 114. The proximal cap 116 can include and/or house a proximal aperture 124, also referred to herein as a proximal channel 124, a first channel 124, or a first aperture 124, that extends through the proximal cap 116, and the distal cap 120 can include and/or house a distal aperture 126, also referred to herein as a distal channel 126, a second channel 126, or second aperture 126, that extends through the distal cap 120. As seen in FIG. 1, the distal cap 120 connects to the shaft 106 of the catheter 102 at the distal end 122 of the valve 104.

The proximal cap 116 and the distal cap 120 are connected via a housing 128. The housing 128 can be a one-piece housing 128 or a multi-piece housing 128. In the embodiment depicted in FIG. 1, the housing comprises a two-piece housing 128. The housing 128 can be configured to receive and couple with each of the proximal cap 116 and the distal cap 120, and as seen in FIG. 1, the housing 128 is coupled with each of the proximal cap 116 and the distal cap 120 to secure the relative position of the proximal cap 116 and the distal cap 120 with respect to each other.

The housing 128 can define an interior channel 130 through which an elongate member 132, also referred to herein as a tubular member 132, a septum 132, or a tubular septum 132, can extend and connect the proximal cap 116 and the distal cap 120. The elongate member 132 can comprise a variety of shapes and sizes and can be made from a variety of materials. In some embodiments, the elongate member 132 can comprise a compliant tubular structure that can be, for example, a thin-walled compliant tubular structure. The thin-walled structure of the elongate member 132 can facilitate the collapse, and specifically the uniform collapse of the elongate member 132 and the sealing of the elongate member 132. In some embodiments, the elongate member 132 is an elastic, resilient material that may comprise a polymer including either a natural or synthetic polymer. In some embodiments, the elongate member can comprise an elastic, resilient material that may comprise silicone, urethane, ethylene-vinyl acetate, natural or synthetic rubber or other elastomers known in the art. In some embodiments, the elongate member 132 can comprise a silicone tube.

The elongate member 132 can comprise a proximal end 134, also referred to herein as a first end 134, that can couple to the proximal cap 116, and a distal end 136, also referred to herein as a second end 136, that can couple to the distal cap 120. The elongate member 132 can define a central lumen 138 that can extend from the first end 134 to the second end 136 of the elongate member 132. The elongate member 132 can be coupled to the proximal cap 116 such that the central lumen 138 is fluidly coupled with the proximal aperture 124 of the proximal cap 116, and the elongate member 132 can be coupled to the distal cap 120 such that the central lumen 138, as seen in FIG. 2 and in FIG. 3, is fluidly coupled with the distal aperture 126 of the distal cap 120.

The central lumen 138 of the elongate member 132 can be defined by a wall of the elongate member 132 that can have a thickness that is uniform along the length of the elongate member 132 between the first end 134 and the second end 136, or that is non-uniform along the length of the elongate member 132 between the first end 134 and the second end 136. In some embodiments, the wall can have a thickness that is approximately between 0.005 inches and 0.05 inches, and/or approximately between 0.010 inches and 0.030 inches. As used anywhere herein, "approximately" refers to a range of +/-10% of the value and/or range of values for which "approximately" is used.

In some embodiments, the elongate member 132 can be cylindrically shaped, and specifically can be circular-cylindrically shaped. In some embodiments, the elongate member 132 can be dog-bone shaped to facilitate, for example, connection to each of the proximal cap 116 and the distal cap 120. In some embodiments, the elongate member 132 can include one or several outward-extending protuberances that engage with all or portions of a constricting mechanism 141, also referred to herein as a tensioning mechanism 141, of the valve 104 to secure a position of all or portions of the

constricting mechanism 141 with respect to the elongate member 132. In some embodiments, the constricting mechanism 141 can be self-adjusting to seal around tools of different sizes extending through the valve 104.

The constricting mechanism 141 can, in some embodiments, collapse and seal the elongate member 132 via compression and/or constriction, and specifically via constriction with at least one filament 150. The constricting mechanism 141 can comprise: an actuator 142 which can be a manual actuator such as one or several buttons 144; and the at least one filament 150 that can extend at least partially around the elongate member 132. In some embodiments, the use of the constricting mechanism 141 can facilitate sealing of the valve around tools or instruments of a wide range of sizes and/or diameters, and particularly around tools or instruments that fit through the elongate member 132.

The housing 128 can further include one or several retention features 140. The one or several retention features 140 of the housing can engage with and retain all or portions of the constricting mechanism 141 of the valve 104. In some embodiments, the one or several retention features 140 of the housing 128 can retain the actuator 142 and/or can couple the actuator 142 to the housing 128. The actuator 142 can comprise any desired type of actuator including, for example, a manual actuator and/or an automated actuator such as, for example, an electromechanical actuator including a solenoid-based actuator. In some embodiments, the actuator can comprise one or several buttons 144, and specifically, as depicted in FIG. 1, the actuator 142 can comprise a first button 144-A and a second button 144-B. Alternatively, and as depicted in FIG. 5, the actuator 142 can comprise a single button 144. In such an embodiment, the filament 150 can be coupled to the single button 144 and to a portion of the housing 128 such as, for example, to grip portion 500 of the housing 128 such that the movement of the single button 144 causes the sealing and/or opening of the elongate member 132 and of the valve 104.

The actuator 142 can be biased towards a configuration such as, for example, biased towards the first configuration or biased towards the second configuration. As depicted in FIG. 2, which shows the constricting mechanism 141 in the first configuration, the actuator 142 can be biased towards the first configuration wherein the elongate member 132 is collapsed and/or sealed by a bias feature 146. In this first configuration, the buttons 144 can be in a first position, also referred to herein as an undepressed position. This bias feature 146 can, as shown in FIG. 2, include a first spring 148-A configured to bias the first button 144-A towards the first position corresponding to the first configuration of the constricting mechanism 141, and a second spring 148-B configured to bias the second button 144-B towards a first position corresponding to the first configuration of the constricting mechanism 141. One or both of the first spring 148-A and the second spring 148-B can comprise a tension spring, compression spring, a torsion spring, a coil spring, or any other desired type of spring.

In some embodiments, one or both of the first spring 148-A and the second spring 148-B can generate sufficient force so as to allow actuation of the actuator 142 with a single hand and so as to collapse and seal the elongate member 132 when the constricting mechanism 141 is in the first configuration. In some embodiments, one or both of the first spring 148-A and the second spring 148-B can generate a force of: at least 0.1 pounds, at least 0.2 pounds, at least 0.3 pounds, at least 0.4 pounds, at least 0.5 pounds, at least 0.6 pounds, at least 0.7 pounds, at least 0.8 pounds, at least 0.9 pounds, at least 1 pound, at least 1.5 pounds, at least 2

pounds, at least 3 pounds, at least 5 pounds, and/or at least 10 pounds and in some embodiments one or both of the first spring 148-A and the second spring 148-B can generate a force approximately between: 0.1 and 10 pounds, 0.1 and 5 pounds, 0.1 and 1.5 pounds, 0.2 and 1 pounds, and/or 0.4 and 0.8 pounds.

The constricting mechanism 141 can include at least one filament 150 that extends at least partially around the elongate member 132. In some embodiments, the at least one filament 150 can circumferentially constrict the elongate member 132 to collapse and seal the elongate member 132 when the constricting mechanism 141 is in the first configuration. The filament can be made from a variety of materials including, for example, a polymer, a synthetic, and/or a metal. In some embodiments, the filament 150 can be nylon, stainless steel, nitinol, silicone, or the like. In some embodiments, the filament can comprise a single strand such as, for example, a monofilament, and in some embodiments, the filament can comprise a plurality of strands that can be, for example, twisted, woven, grouped, and/or fused to form the filament. In some embodiments, the filament 150 can comprise one or several threads, lines, cords, rope, ribbon, flat wire, sheet, or tape.

The filament 150 can be coupled to the actuator 142 such that the filament 150 selectively constricts, collapses, and/or seals the elongate member 132, and specifically the central lumen 138 of the elongate member 132 based on the movement and/or position of the actuator 142. In some embodiments, the filament 150 can be connected to one or both of the buttons 144-A, 144-B such that the filament 150 collapses, constricts, and/or seals the elongate member 132 and specifically the central lumen 138 of the elongate member 132 when the buttons 144-A, 144-B are in the first position, and the filament 150 can be connected to one or both of the buttons 144-A, 144-B such that the elongate member 132 and specifically the central lumen 138 of the elongate member 132 is open and uncollapsed when the buttons 144-A, 144-B are in the second position. In some embodiments in which the actuator 142 comprises a single button 144, as depicted in FIG. 5, the filament 150 can be connected to the button 144 and to the housing 128 such that the filament 150 is tightened when the button 144 moves to the first position.

In some embodiments, the at least one filament 150 can extend along an axis 152 that can be perpendicular to a central axis 154 of the elongate member 132 and/or of the apertures 124, 126. In some embodiments, the axis 152 of the at least one filament 150 can intersect and be perpendicular to the central axis 154 of the elongate member 132 and/or of the apertures 124, 126. In some embodiments, the actuator 142, and specifically the buttons 144-A, 144-B can move along this axis 152 when moved from the first position to the second position.

In FIG. 3, an embodiment of the valve 104 with the constricting mechanism 141 in the second configuration is shown. As specifically shown, both of the first and second buttons 144-A, 144-B are in the second position, depressed into the retention features 140 of the housing 128. In this second position, the filament 150 is loosened, thereby allowing the expansion of the elongate member 132 and the unscaling of the central lumen 138 of the elongate member 132.

As further seen in FIG. 3, the proximal cap 116 has a proximal end 300 and a distal end 302. The proximal cap 116 can include a funnel portion 301 of the proximal aperture 124, which funnel portion 301 can facilitate insertion of a tool into the proximal aperture 124. The distal end 302 of the

proximal cap 116 can partially extend into the interior channel 130 of the housing 128. The proximal cap 116 can include a mating feature 304 that can mate with the proximal end 134 of the elongate member 132. In some embodiments, the proximal end 134 of the elongate member 132 can fit over the mating feature 304 of the proximal cap 116. The proximal end 134 of the elongate member 132 can be compressed between the mating feature 304 of the elongate member 132 and a portion of the interior channel 130 of the housing 128 into which the mating feature 304 is inserted to thereby secure the proximal end 134 of the elongate member 132 on the mating feature 304. In some embodiments, the proximal end 134 of the elongate member 132 can be further secured on the mating feature 304 by a proximal O-ring 306 that can be compressed between the housing 128 and the mating feature 304 of the proximal cap 116 to sealingly couple the elongate member 132 to the proximal cap 116.

The distal cap 120 has a proximal end 308 and a distal end 310. The distal cap can include a mating feature 312 located on the proximal end 308 of the distal cap 120, which mating feature 312 can mate with the distal end 136 of the elongate member 132. In some embodiments, the distal end 136 of the elongate member 132 can fit over the mating feature 312 of the distal cap 123. The distal end 136 of the elongate member 132 can be compressed between the mating feature 312 of the elongate member 132 and a portion of the interior channel 130 of the housing 128 into which the mating feature 312 is inserted to thereby secure the distal end 136 of the elongate member 132 on the mating feature 312. In some embodiments, the distal end 136 of the elongate member 132 can be further secured on the mating feature 312 by a distal O-ring 314 that can be compressed between the housing 128 and the mating feature 312 of the proximal cap 116 to sealingly couple the elongate member 132 to the distal cap 120.

The distal cap 120 can, in some embodiments, further include a side port barb 314 that can extend laterally away from the distal cap 120 and specifically away from the distal aperture 126 of the distal cap 120. The side port barb 314 can define a side port channel 316 that can extend through the side port barb 314 and fluidly connect to the distal aperture 126. In some embodiments, the side port barb 314 can include a securement feature 318 such as a barb that can secure coupling of a hose or tube to the side port barb 314.

In some embodiments, the side barb 314 can be used to apply a vacuum to the portions of the delivery device 100, and particularly to portions of the delivery device 100 that are distal of the axis 152 along which the elongate member 132 seals. This vacuum can be applied to aspirate a material through the delivery device 100, and specifically through the catheter 102 of the delivery device. This aspirated material can be a biological material including, for example, bodily fluids, multi-phase bodily materials that can include, for example, a fluidic portion and at least one solid portion, or the like.

In some embodiments, due to the narrowing shape of the elongate member 132 when the constricting mechanism 141 is in the first configuration, a vacuum applied to the portions of the delivery device 100 distal to the axis 152 draws the elongate member 132 towards the first configuration and can, in some embodiments, increase the strength, robustness, and/or strength of the seal of the valve 104. This attribute of the valve 104 can provide benefits over other valve designs in which a vacuum can compromise the seal of the valve, and thus the ability to draw a vacuum and aspirate can be limited.

11

In some embodiments, the valve **104** can further include a reinforcement structure **320** that can extend along all or portions of the elongate member **132**. The reinforcement structure **320** can facilitate the uniform collapse of the elongate member **132**, can prevent the at least one filament **150** from cutting through and/or tearing the elongate member **132**, and can assist in guiding one or several tools through the elongate member **132**. The reinforcement structure **320** can be tubular, can extend along and around the elongate member **132**, and can be positioned so as to be between the elongate member **132** and the at least one filament **150**.

The reinforcement structure **320** can include a proximal end **322** and a distal end **324**. In some embodiments, the reinforcement structure **320** extends along and around the elongate member **132**, and is positioned such that the proximal end **322** of the reinforcement structure **320** is proximate to the first end **134** of the elongate member **132** and the distal end **324** of the reinforcement structure **320** is proximate to the second end **136** of the elongate member **132**.

The reinforcement structure **320** can be coupled to the elongate member **132**. In some embodiments, the reinforcement structure **320** is coupled to the elongate member **132** along the length of the reinforcement structure **320**, and in some embodiments, the reinforcement structure **320** is coupled to the elongate member **132** and distinct positions along the length of the elongate member **132** and/or the reinforcement structure **320**. In one embodiment, for example, the reinforcement structure **320** can be coupled to the elongate member **132** at one or both of the proximal end **322** of the reinforcement structure **320** and the distal end **324** of the reinforcement structure **320** and/or at one or both of the first end **134** and the second end **136** of the elongate member **132**. In some embodiments, the reinforcement structure **320** can be coupled to the elongate member **132** via one or several other components of the valve **104**. In some embodiments, the reinforcement structure **320** can be coupled to the elongate member **132** via the compression of the reinforcement structure **320** and the elongate member **132** between the housing **128** and one or both of the proximal **116** and the distal **120**.

In some embodiments, the reinforcement structure **320** can be adhered to the elongate member **132** via, for example, an adhesive such as silicone adhesive. In some embodiments, the adhesive can be circumferentially applied to the reinforcement structure **320** and/or the elongate member **132** in an adhesive ring that can, for example, have a length approximately between: 0.010 inches and 0.5 inches; 0.02 and 0.4 inches; 0.050 inches and 0.0250 inches, or any other or intermediate range.

In one embodiment, each of the proximal end **322** and the distal end **324** of the reinforcement structure **320** can be adhered via an adhesive to the elongate member **132**. In such an embodiment, the reinforcement structure **320** may be uncoupled to the elongate member **132** at positions other than the coupling at one or both of the proximal end **322** and the distal end **324** of the reinforcement structure **320**, and thus the reinforcement structure **320** is uncoupled to the elongate member **132** at a position between the first end **134** and the second end **136** of the elongate member **132** and/or between the proximal end **322** and the distal end **324** of the reinforcement structure **320**.

The lack of coupling of the reinforcement structure **320** to the elongate member **132** can facilitate and improve the collapse of the elongate member **132** around a tool **400**, also referred to herein as instrument **400** or device **400**, inserted

12

through the valve **104** as shown in FIG. 4. The tool **400** can be any device inserted through the valve **104** including, for example, one or several additional catheters, lines, wires, grippers, punches, cutters, or the like. As seen in FIG. 4, the tool **400** is inserted through the valve **104** and specifically through the elongate member **132** of the valve. As shown, the constricting mechanism **141** is in the first configuration and the elongate member **132** and the central lumen **138** of the elongate member **132** is collapsed around the tool **400**, and specifically around a shaft **402** of the tool **400** to thereby seal the valve **104** around the tool **400** and specifically around the shaft **402** of the tool **400**. The constricting mechanism **141** can seal around tools **400** that fit through the elongate member **132**, regardless of the size of the tool **400**. Thus, the valve can be used with a wide variety of tools.

The reinforcement structure **320** can comprise a variety of designs, shapes, sizes, and materials. In some embodiments, the reinforcement structure **320** can be sized and shaped so as to receive elongate member **132** and to be positioned between the elongate member **132** and the at least one filament **150**. In some embodiments, the reinforcement structure **320** can be made from a material sufficiently strong to prevent the cutting of the at least one filament **150** through the elongate member **132**.

In some embodiments, the reinforcement structure can comprise a coil or a mesh sheath. The mesh sheath can, in some embodiments, comprise a braided mesh. The braided mesh can be made from any desired number of wires in any desired configuration. In some embodiments, the braided mesh can comprise a 4 wire braided mesh, an 8 wire braided mesh, a 12 wire braided mesh, a 16 wire braided mesh, a 20 wire braided mesh, a 24 wire braided mesh, a 32 wire braided mesh, a 48 wire braided mesh, a 64 wire braided mesh, a 72 wire braided mesh, an 80 wire braided mesh, a 96 wire braided mesh, or any other or intermediate braided mesh. In some embodiments, the braided mesh can comprise: a 1x1 configuration. In some embodiments, the wire in the braided mesh can be any desired material including, for example, a metal wire such as a nitinol wire or a stainless steel wire, a polymer wire, or a natural wire. In one embodiment, the braided mesh can comprise a 48 wire mesh in a 1x1 configuration made with a nitinol wire having a diameter of 0.003 inches.

With reference now to FIGS. 6 through 9, different embodiments and/or configurations of the filament **150** are shown. The filament **150** can comprise a single filament **150** having a first end **600** and a second end **602** as shown in FIG. 6. The filament **150**, and specifically which first and second ends **600**, **602** can be coupled to the actuator **142** to move the filament **150** between the first and second configurations or positions and/or from the first configuration or position to the second configuration or position. In some embodiments, both of the first end **600** and the second end **602** can be coupled to a single button **144**, in some embodiments, each of the first end **600** and the second end **602** can be coupled to different buttons **144**, and in some embodiments, one of the first end **600** and the second end **602** can be coupled to a button **144** and the other of the first end **600** and the second end **602** can be coupled to the housing **128** or other portion of the valve **104**.

In some embodiments, the filament **150** can comprise multiple filaments, and specifically, as shown in FIGS. 7 through 9, the filament **150** can comprise a first filament **150-A** and a second filament **150-B**. In embodiments in which the filament **150** comprises multiple filaments, each of the multiple filaments can have a first end **700** and a second end **702**. The first and second filaments **150-A**,

150-B can be coupled to the actuator 142. In such embodiments, the first and second ends 700, 702 can be coupled to the actuator 142 to move the filaments 150-A, 150-B between the first and second configurations and/or from the first configuration to the second configuration. In some 5
embodiments, both of the first end 700 and the second end 702 of one or more of the multiple filaments 150 can be coupled to a single button 144, in some embodiments, each of the first end 700 and the second end 702 of one or more of the multiple filaments 150 can be coupled to different 10
buttons 144, and in some embodiments, one of the first end 700 and the second end 702 of one or more of the multiple filaments 150 can be coupled to one button 144 and the other of the first end 700 and the second end 702 of those one or more filaments 150 can be coupled to the housing 128 or 15
other portion of the valve 104.

The filament 150 can be arranged in a variety of configurations. In some embodiments, the filament 150 can be configured to form a single loop 604 that can extend around the elongate member 132 and/or through which the elongate 20
member 132 can be received as shown in FIG. 6, and in some embodiments, the filament 150 can be configured to form multiple loops, and specifically a first loop 704 and a second loop 706 as shown in FIG. 7. The first and second loops 704, 706 can each receive the elongate member 132. 25
In some embodiments, a diameter or size of the loop 604, or of the loops 704, 706 can decrease when the constricting mechanism 141 is moved from the second configuration to the first configuration.

In some embodiments, the filament 150 can be configured 30
to form a bight 800, which bight 800 can be a single bight or multiple bights. As used herein, a “bight” refers to a U-shaped section between the two ends of the filament 150. As depicted in FIGS. 8 and 9, the bight 800 can comprise multiple bights, and specifically a first bight 800-A and a 35
second bight 800-B. In some embodiments, the first bight 800-A can extend through the second bight 800-B such that the first and second bights 800-A, 800-B interlock, whereas in other embodiments, the first and second bights 800-A, 800-B can be non-interlocking. Similarly, in embodiments 40
containing the filament 150 having multiple loops, one or several of the multiple loops can be interlocking.

In some embodiments, the bight 800, and specifically one or both of the first bight 800-A and the second bight 800-B can be formed around a portion of the elongate member 132 45
and/or can extend around a portion of the elongate member 132. Each bight 800 can define a partially enclosed receiving area 808 wherein the elongate member 132 can be received. Thus, the first bight 800-A can define a first receiving area 808-A and the second bight 800-B can define a second 50
receiving area 808-B.

As seen in FIGS. 8 and 9, multiple bights, and specifically the first and the second bights 800-A, 800-B can be positioned and oriented such that the first bight 800-A has a first orientation or first direction as indicated by arrow 810, and 55
the second bight has a second orientation or second direction as indicated by the arrow 812. In some embodiments, the first orientation is different from the second orientation such that the first and second receiving areas 808-A, 808-B overlap and define an encircled area 814, also referred to 60
herein as a constricting area 814. The elongate member 132 can be received within the encircled area 814. In embodiments in which bights 800-A, 800-B overlap to define the encircled area 814, the movement of the constricting mechanism 141 to the first configuration can result in and/or 65
include the first bight 800-A moving in the direction indicated by the arrow 810 and/or the second bight 800-B

moving in the direction indicated by the arrow 812, which movement of the bights 800-A, 800-B decreases the size of the encircled area 814 and constricts, collapses, and/or seals the elongate member 132 extending through the encircled 5
area 814.

The filament(s) 150 forming the bights 800 can each apply an arcuate line or narrow longitudinal zone of pressure to the elongate member 132. If the filament(s) are circular in cross-section, the zone of pressure can be very small, and can, in some embodiments, be less than the diameter or 10
thickness of the filament. In some embodiments, the filaments have a diameter or width less than about 2.5 mm, less than about 2 mm, less than about 1.5 mm, less than about 1.25 mm, less than about 1 mm, less than about 0.75 mm, less than about 0.5 mm, and/or less than about 0.25 mm. In some embodiments, the filaments can have a diameter or width of between about 0.01 mm and 2.5 mm, between 15
about 0.05 mm and 2 mm, between about 0.1 mm and 1 mm, and/or between about 0.125 mm and 0.70 mm. In some embodiments, the arcuate line or zone of pressure may form two opposing arcs and in other embodiments, the arcuate line of pressure may be a singular substantially circular line or zone that encircles the elongate member at least once. The longitudinal length of the of the line or zone of pressure may be very short compared to other valves known in the art. In some embodiments, the longitudinal length of the zone of 20
pressure applied to the elongate member 132 by the filament (s) 150 may be less than about 2.0 mm and in some embodiments less than about 0.5 mm. In some embodiments, the filament(s) 150 can have any desired cross-sectional shape including, for example, a circular cross-section, a rectangular cross-section, an oval cross-section, a square cross-section, a polygonal cross-section, a triangular cross-section, or any other desired shape of cross-section.

With reference now to FIG. 10, a flowchart illustrating one embodiment of a process 1000 for sealing a valve 104 25
and/or catheter 102 accessing a body of a patient is shown. The process 1000 can be performed using the valve 104 and/or the delivery system 100. The process 1000 begins at block 1002, wherein the delivery device 100, and specifically the catheter 102 of the delivery device 100 is inserted into the body of the patient. In some embodiments, this can include inserting the catheter 102 into a portion of the circulator system of the patient such as, for example, a blood 30
vessel including an artery or a venous vessel. In some embodiments, the delivery device 100 can be inserted into the body of the patient directly through an aperture or incision in the patient, and in some embodiments, the delivery device 100 can be inserted into the body of the patient via another catheter or device. In some embodiments, the constricting mechanism 141 can be in the first configuration while the delivery device 100 and/or the catheter 102 35
is inserted into the patient's body.

After the delivery device 100 is inserted into the body of the patient, the process 1000 proceeds to block 1004, wherein the constricting mechanism 141 is moved from the first configuration to the second configuration. As described above, the central lumen 138 of the elongate member 132 is unsealed when the constricting mechanism 141 is in the second configuration. In some embodiments, the moving of the constricting mechanism 141 from the first configuration to the second configuration can include the manipulation of the actuator 142 and/or the control of the actuator 142, and specifically the depressing of the one or several buttons 144 40
to move the filament 150 from the first position to the second position to allow the expansion and opening of the central lumen 138 of the elongate member 132. 65

15

After the constricting mechanism **141** is moved from the first configuration to the second configuration, the process **1000** proceeds to block **1006**, wherein the tool **400**, and specifically the shaft **402** of the tool **400** is advanced through the delivery device **100** and specifically through the valve **104** until a first end of the tool reaches a desired position within the body of the patient. In some embodiments, a portion of the shaft **402** can be positioned within the central lumen **138** of the elongate member **132** after the advancing of the tool **400** through the delivery device **100**. In some embodiments, after the tool **400** is advanced through the delivery device **100**, the desired procedure can be performed with the tool.

After the tool **400** is advanced through the delivery device **100**, or while the tool **400** is being advanced through the delivery device **100**, the process **1000** proceeds to block **1008**, wherein the constricting mechanism **141** is returned to the first configuration. In some embodiments, the returning of the constricting mechanism **141** to the first configuration can include the release of the one or several buttons **144** and/or the control of the actuator **142** to reconfigure the constricting mechanism **141** to the first configuration. In some embodiments, the return of the constricting mechanism **141** to the first configuration can result in the collapse and/or sealing of the elongate member **132** and specifically the central lumen **138** of the elongate member **132** around the tool **400** and specifically around the shaft **402** of the tool **400**. The return of the constricting mechanism **141** to the first configuration, or the movement of the constricting mechanism **141** to the first configuration can include the decreasing of the size and/or diameter of one or several loops formed by the filament **150** and/or the movement of one or several bights **800** such as, for example, the movement of the first bight **800-A** in the first direction indicated by arrow **810** and the movement of the second bight **800-B** in the second direction indicated by arrow **812** to reduce the size of the constricting area **814**. In some embodiments, after the constricting mechanism is returned to the first configuration, the desired procedure can be performed with the tool.

After the constricting mechanism is returned to the first configuration, the process **1000** proceeds to block **1010**, wherein the tool **400**, and specifically the shaft **402** of the tool **400** is retracted from the delivery device **100**, and more specifically from the valve **104**. In some embodiments, the valve **104** can remain sealed during the retracting of the tool **400** and/or the shaft **402** of the tool. In some embodiments, the valve **104** remains sealed during the retracting of the tool **400** and/or the retracting of the shaft **402** of the tool **400** as the constricting mechanism **141** can remain in the first configuration during the retracting of the tool **400** and/or the shaft **402** of the tool **400**.

In some embodiments, the constricting mechanism **141** can be moved to the second configuration to allow the retraction of the tool **400** and/or the shaft **402** of the tool **400** from the valve **104**, and the constricting mechanism **141** can be returned to the first configuration when the tool **400** and/or the shaft **402** of the tool **400** is removed from the valve **104**. In some embodiments, the retraction of the tool **400** and/or shaft **402** of the tool **400** from the valve **104** can be performed with the constricting mechanism **141** left in the first configuration. In some embodiments, the constricting mechanism **141** can be moved to the second configuration, and then returned to the first configuration via the manipulation and/or control of the actuator **142**, which manipulation and/or control of the actuator **142** can include the depressing of the one or several buttons **144** to move the constricting mechanism **141** to the second configuration, and

16

the release of the one or several buttons **144** to return the constricting mechanism **141** to the first configuration. In some embodiments, if the procedure is complete, the delivery device **100** can then be removed from the body of the patient, and any incision created for the procedure can be closed.

With reference now to FIG. **11**, a side view of one embodiment of a thrombectomy system **1100** including the delivery device **100** and a thrombus extraction device **1102** is shown. In some embodiments, the thrombectomy system **1100** can be used to access a blood vessel **1104** to treat and/or extract a thrombus **1106** from the blood vessel **1104**. The thrombus extraction device **1102** can include a self-expanding coring element **206** and expandable cylindrical portion **208**. In some embodiments, and as shown in FIG. **11**, the thrombus extraction device **1102** can be the tool **400** that can extend through the valve **104**, and in some embodiments, the valve **104** can be a part of the thrombus extraction device **1102**. Further details of thrombectomy systems, thrombus extraction devices, and methods of using the same are disclosed in: U.S. application Ser. No. 15/268,296, filed Sep. 16, 2016, and entitled "INTRAVASCULAR TREATMENT OF VASCULAR OCCLUSION AND ASSOCIATED DEVICES, SYSTEMS, AND METHODS"; U.S. application Ser. No. 15/498,320, filed Apr. 26, 2017, and entitled "DEVICES AND METHODS FOR TREATING VASCULAR OCCLUSION"; and U.S. application Ser. No. 15/466,740, filed on Mar. 22, 2017, and entitled "DEVICE AND METHOD FOR TREATING VASCULAR OCCLUSION", the entirety of each of which is hereby incorporated by reference herein.

With reference now to FIG. **12**, a side-section view of another embodiment of the hemostasis valve **104** having two piece caps **116**, **120** is shown. The valve **104** can include a housing **128** defining an interior channel **130** through which the tubular member **132** can extend. The valve **104** can include the proximal cap **116** and the distal cap **120**. In some embodiments, the proximal cap **116** can comprise a two piece cap and can include a proximal exterior member **1200** and a proximal channel member **1202**. In some embodiments, the distal cap **120** can comprise a two-piece cap and can include a distal exterior member **1204** and a distal channel member **1206**. In some embodiments, this coupling between the proximal exterior member **1200** and the proximal channel member **1202** and/or the coupling between the distal exterior member **1204** and the distal channel member **1206** can be a sealed coupling so as to prevent the leakage of material including fluid or gas between the respective ones of the proximal exterior member **1200** and the proximal channel member **1202** and/or the distal exterior member **1204** and the distal channel member **1206**. In some embodiments, this sealing coupling can be achieved and/or maintained via a seal such as an O-ring **1208** that can be positioned between the proximal exterior member **1200** and the proximal channel member **1202** and/or between the distal exterior member **1204** and the distal channel member **1206**.

In some embodiments, the proximal exterior member **1200** can be coupled, and in some embodiments, rotatably coupled to the proximal channel member **1202** in a manner to allow the rotation of the proximal exterior member **1200** without rotating the proximal channel member **1202**. Similarly, in some embodiments, the distal exterior member **1204** can be rotatably coupled to the distal channel member **1206** in a manner to allow the rotation of the distal exterior member **1204** without the rotating of the distal channel member **1206**. In some such embodiments, the channel

members **1202**, **1206** can be non-rotatable with respect to the housing **128** and/or the tubular member **132**, and one or both of the exterior members **1200**, **1204** can be rotatable with respect to the housing **128** and/or the tubular member **132**. In such an embodiment, the maintaining of the rotational position of the channel members **1202**, **1206** with respect to the housing **128** and/or the tubular member **132** can prevent the twisting of the tubular member **132** which can result in the sealing of the tubular member **132** regardless of the configuration of the constructing mechanism **141**.

The exterior members **1200**, **1204** can comprise a variety of shapes and sizes and can include a variety of features. In some embodiments, one or both of the exterior members **1200**, **1204** can be coupled to, for example, a shaft similar to the shaft **106** shown in FIG. 1. In some embodiments, for example, the distal exterior member **1204** can be coupled to a shaft **106**, including, for example, can be non-detachably coupled to the shaft **106**. In some embodiments, one or both of the exterior members can include one or several features configured to facilitate coupling with the valve **104**. These one or several features can include, for example, one or several male or female: connectors; couplers; attachment mechanisms; or the like. In some embodiments, these one or several features can facilitate use of the valve with other existing components, instruments, tools, or the like. In some embodiments, for example, one or both of the exterior members **1200**, **1204** can comprise either a male or female luer fitting, and specifically as shown in FIG. 12, the distal exterior member **1204** can comprise a male luer fitting **1210**.

Several aspects of the present technology are set forth in the following examples.

1. A hemostatic valve for sealing a medical device, the hemostatic valve comprising:

an elongate member having a first end, a second end, and a central lumen extending therebetween, wherein the elongate member is pliable;

a reinforcement structure extending along at least a portion of the elongate member, wherein the reinforcement structure is coupled to the elongate member; and

an active tensioning mechanism coupled to the elongate member, wherein the tensioning mechanism is moveable between a first configuration wherein the central lumen is constricted and sealed and a second configuration wherein the central lumen is open.

2. The hemostatic valve of example 1, wherein the elongate member comprises a compliant polymer tube.

3. The hemostatic valve of example 1 or 2, wherein the tensioning mechanism comprises at least one filament extending at least partially around the elongate member.

4. The hemostatic valve of example 3, wherein the reinforcement structure is positioned between the at least one filament and the elongate member.

5. The hemostatic valve of example 4, wherein the reinforcement structure comprises a braided mesh.

6. The hemostatic valve of example 4 or 5, wherein the reinforcement structure is coupled to the elongate member at a position proximate to the first end of the elongate member and at a position proximate to the second end of the elongate member.

7. The hemostatic valve of example 6, wherein the reinforcement structure is not coupled to the elongate member at a position between the first end of the elongate member and the second end of the elongate member.

8. The hemostatic valve of any one of examples 3-7, wherein the tensioning mechanism comprises an actuator coupled to the at least one filament, wherein the actuator is moveable to control movement of the at least one filament

from a first position wherein the central lumen is constricted and sealed to a second position wherein the central lumen is open, wherein the at least one filament is in the first position when the tensioning mechanism is in the first configuration.

9. The hemostatic valve of example 8, wherein the actuator is biased towards the first position.

10. The hemostatic valve of example 8 or 9, wherein the actuator is biased toward the second position.

11. The hemostatic valve of any one of examples 8-10, wherein the actuator comprises a manual actuator.

12. The hemostatic valve of any one of examples 8-11, wherein the at least one filament forms a loop around the elongate member.

13. The hemostatic valve of any one of examples 8-12, wherein the at least one filament forms a bight around a portion of the elongate member.

14. The hemostatic valve of any one of examples 8-13, wherein the at least one filament comprises a first filament and a second filament, wherein each of the first filament and the second filament are coupled to the actuator, and wherein the first filament and the second filament are moveable from the first position to the second position.

15. The hemostatic valve of example 14, wherein each of the first filament and the second filament form a loop around the elongate member.

16. The hemostatic valve of example 14 or 15, wherein the first filament forms a first bight around a first portion of the elongate member, and wherein the second filament forms a second bight around a second portion of the elongate member.

17. The hemostatic valve of example 16, wherein the first bight extends through the second bight.

18. The hemostatic valve of any one of examples 1-17, further comprising a shell defining a first aperture and a second aperture, wherein the elongate member extends from the first aperture to the second aperture and fluidly couples the first aperture and the second aperture.

19. The hemostatic valve of any one of examples 1-18, wherein the tensioning mechanism is self-adjustable to seal around tools of different sizes extending through the hemostatic valve.

20. The hemostatic valve of any one of examples 1-19, wherein the central lumen comprises a single lumen.

21. The hemostatic valve of any one of examples 1-20, wherein the central lumen comprises a plurality of lumens.

22. A delivery system for intravascular access of a blood vessel within a patient's body, the delivery system comprising:

a catheter having a first end, a second end, and a catheter lumen extending therebetween;

a hemostatic valve coupled to the first end of the catheter, the hemostatic valve comprising:

a tubular member having a first end, a second end, and a central lumen extending therebetween, wherein the central lumen of the tubular member is fluidly coupled with the catheter lumen; and

an active tensioning mechanism coupled to the tubular member, the tensioning mechanism moveable between a first configuration wherein the tensioning mechanism constricts on the central lumen and the central lumen is sealed and a second configuration wherein the central lumen is open.

23. The delivery system of example 22, wherein the hemostatic valve further comprises a reinforcement structure extending along at least a portion of the tubular member.

24. The delivery system of example 22 or 23, wherein the reinforcement structure is located between the tensioning mechanism and the tubular member.

25. The delivery system of example 24, wherein the reinforcement structure comprises a braided mesh.

26. The delivery system of example 24 or 25, wherein the reinforcement structure is coupled to the tubular member at a position proximate to the first end of the tubular member and at a position proximate to the second end of the tubular member.

27. The delivery system of example 26, wherein the reinforcement structure is adhered to the tubular member at the first end of the tubular member and at the second end of the tubular member.

28. The delivery system of example 27, wherein the reinforcement structure is uncoupled to the tubular member between the first end of the tubular member and the second end of the tubular member.

29. The delivery system of any one of examples 22-28, wherein the tensioning mechanism comprises at least one filament extending at least partially around the tubular member.

30. The delivery system of example 29, wherein the tensioning mechanism comprises an actuator coupled to the at least one filament, wherein moving the tensioning mechanism from the first configuration to the second configuration comprises moving the actuator and the thereto coupled at least one filament from a first position to a second position, wherein the filament constricts and seals the central lumen of the tubular member when the filament is in the first position.

31. The delivery system of example 30, wherein the actuator comprises a manual actuator.

32. The delivery system of example 31, wherein the actuator comprises a pair of opposing and depressable buttons, wherein the buttons are biased towards an undepressed position.

33. The delivery system of example 31 or 32, wherein the central lumen is sealed when the buttons are in the undepressed position.

34. The delivery system of any one of examples 30-33, wherein the filament comprises a monofilament.

35. The delivery system of any one of examples 30-34, wherein the filament comprises at least one of: a polymer filament; or a metallic filament.

36. The delivery system of any one of examples 22-35, wherein the catheter comprises a thrombus extraction device.

37. A method of sealing a delivery device accessing a blood vessel of a patient, the method comprising:

inserting the delivery device comprising a catheter and a hemostatic valve into the blood vessel of the patient, the catheter having a first end, a second end, and a catheter lumen extending therethrough, and the hemostatic valve coupled to the first end and having a tubular member defining a central lumen fluidly coupled with the catheter lumen and a tensioning mechanism coupled with the tubular member, wherein the tensioning mechanism collapses and seals the central lumen in a first configuration and thereby seals access to the blood vessel;

moving the tensioning mechanism of the hemostatic valve to a second configuration, wherein the central lumen is open and access to the blood vessel is unsealed when the tensioning mechanism is in the second configuration;

advancing a shaft of a tool through the delivery device until a first end of the tool reaches a desired position within the blood vessel of the patient and a portion of the shaft is positioned within the central lumen of the tubular member; and

returning the tensioning mechanism of the hemostatic valve to the first configuration such that the tubular member collapses on the shaft of the tool and seals around the shaft of the tool.

38. The method of example 37, further comprising retracting the shaft of the tool from the delivery device.

39. The method of example 38, wherein the tensioning mechanism is maintained in the first configuration during and after the retracting of the shaft of the tool from the delivery device.

40. The method of example 38 or 39, wherein the tensioning mechanism is moved to the second configuration during the retracting of the shaft of the tool from the delivery device, and wherein the tensioning mechanism is returned to the first configuration after the shaft of the tool is retracted from the delivery device.

41. The method of any one of examples 37-40, wherein the tensioning mechanism comprises at least one filament extending at least partially around the tubular member, wherein the at least one filament collapses the tubular member when the tensioning mechanism is in the first configuration.

42. The method of example 41, wherein the at least one filament circumferentially constricts the tubular member to collapse the tubular member when the tensioning mechanism is in the first configuration.

43. The method of example 41 or 42, wherein the hemostatic valve comprises a reinforcement structure located between the at least one filament and the tubular member.

44. The method of any one of examples 41-43, wherein the at least one filament forms a loop around the elongate member, and wherein moving the tensioning mechanism from the second configuration to the first configuration reduces a size of the loop to thereby constrict the tubular member within the loop.

45. The method of any one of examples 41-44, wherein the filament forms at least one bight around a portion of the elongate member.

46. The method of example 45, wherein the filament comprises a first filament and a second filament, and wherein the at least one bight comprises a first bight oriented in a first direction and formed by the first filament and a second bight oriented in a second direction and formed by the second filament, wherein the first and second bights overlap to encircle a portion of the tubular member within a constricting area.

47. The method of example 46, wherein moving the tensioning mechanism from the second configuration to the first configuration comprises moving the first bight in the first direction and the second bight in the direction to reduce the size of the constricting area and collapse and seal the central lumen of the tubular member.

48. The method of any one of examples 37-47, wherein the tensioning mechanism comprises an actuator, and wherein moving the tensioning mechanism to the second configuration comprises manipulating the actuator.

49. The method of any one of examples 37-48, further comprising applying a vacuum to the delivery device to aspirate material through the catheter, wherein the central lumen remains sealed during the aspiration.

50. The method of any one of examples 37-49, wherein the tool comprises a thrombus extraction device.

51. A hemostatic valve for sealing a medical device, the hemostatic valve comprising:

an elongate member having a first end, a second end, and a central lumen comprising a plurality of lumens extending therebetween, wherein the elongate member is pliable; and

an active tensioning mechanism coupled to the elongate member, wherein the tensioning mechanism is moveable between a first configuration wherein the central lumen is constricted and sealed and a second configuration wherein the central lumen is open.

Other variations are within the spirit of the present invention. Thus, while the invention is susceptible to various modifications and alternative constructions, certain illustrated embodiments thereof are shown in the drawings and have been described above in detail. It should be understood, however, that there is no intention to limit the invention to the specific form or forms disclosed, but on the contrary, the intention is to cover all modifications, alternative constructions, and equivalents falling within the spirit and scope of the invention, as defined in the appended claims.

In the previous description, various embodiments of the present invention are described. For purposes of explanation, specific configurations and details are set forth in order to provide a thorough understanding of the embodiments. However, it will also be apparent to one skilled in the art that the present invention may be practiced without the specific details. Furthermore, well-known features may be omitted or simplified in order not to obscure the embodiment being described.

The use of the terms “a” and “an” and “the” and similar referents in the context of describing the invention (especially in the context of the following claims) are to be construed to cover both the singular and the plural, unless otherwise indicated herein or clearly contradicted by context. The terms “comprising,” “having,” “including,” and “containing” are to be construed as open-ended terms (i.e., meaning “including, but not limited to,”) unless otherwise noted. The term “connected” is to be construed as partly or wholly contained within, attached to, or joined together, even if there is something intervening. Recitation of ranges of values herein are merely intended to serve as a shorthand method of referring individually to each separate value falling within the range, unless otherwise indicated herein, and each separate value is incorporated into the specification as if it were individually recited herein. All methods described herein can be performed in any suitable order unless otherwise indicated herein or otherwise clearly contradicted by context. The use of any and all examples, or exemplary language (e.g., “such as”) provided herein, is intended merely to better illuminate embodiments of the invention and does not pose a limitation on the scope of the invention unless otherwise claimed. No language in the specification should be construed as indicating any non-claimed element as essential to the practice of the invention.

Preferred embodiments of this invention are described herein, including the best mode known to the inventors for carrying out the invention. Variations of those preferred embodiments may become apparent to those of ordinary skill in the art upon reading the foregoing description. The inventors expect skilled artisans to employ such variations as appropriate, and the inventors intend for the invention to be practiced otherwise than as specifically described herein. Accordingly, this invention includes all modifications and equivalents of the subject matter recited in the claims appended hereto as permitted by applicable law. Moreover, any combination of the above-described elements in all

possible variations thereof is encompassed by the invention unless otherwise indicated herein or otherwise clearly contradicted by context.

All references, including publications, patent applications, and patents, cited herein are hereby incorporated by reference to the same extent as if each reference were individually and specifically indicated to be incorporated by reference and were set forth in its entirety herein.

What is claimed is:

1. A valve assembly, comprising:

a tubular member defining a lumen;

a first filament extending in a first loop around the tubular member, wherein the first filament is flexible;

a second filament extending in a second loop around the tubular member, wherein the second filament is flexible;

a pair of actuators movable from a first position to a second position, wherein—

the first filament includes a first portion operably acted upon by a first one of the actuators and a second portion operably acted upon by a second one of the actuators;

the second filament includes a first portion operably acted upon by the first one of the actuators and a second portion operably acted upon by the second one of the actuators;

in the first position, the actuators are positioned to tension the first filament and the second filament thereby decreasing a dimension of the first loop and a dimension of the second loop to constrict the lumen of the tubular member;

in the second position, the actuators are positioned to loosen the first filament and the second filament thereby permitting the tubular member to expand against the first loop and the second loop to increase the dimension of the first loop and the dimension of the second loop to at least partially open the lumen of the tubular member; and

the actuators are biased to the first position.

2. The valve assembly of claim 1 wherein the first loop extends completely around the tubular member, and wherein the second loop extends completely around the tubular member.

3. The valve assembly of claim 1 wherein the first portion of the first filament is a first end portion of the first filament, wherein the second portion of the first filament is a second end portion of the first filament, wherein the first portion of the second filament is a first end portion of the second filament, and wherein the second portion of the second filament is a second end portion of the second filament.

4. The valve assembly of claim 3 wherein the first end portion of first filament is directly attached to the first one of the actuators, wherein the second end portion of the first filament is directly attached to the second one of the actuators, wherein the first end portion of the second filament is directly attached to the first one of the actuators, and wherein the second end portion of the second filament is directly attached to the second one of the actuators.

5. The valve assembly of claim 1 wherein the tubular member extends along a longitudinal axis, and wherein the first loop is proximate to the second loop along the longitudinal axis.

6. The valve assembly of claim 1 wherein the first filament and the second filament each comprise a plurality of strands woven together.

7. The valve assembly of claim 1 wherein the tubular member is elastically deformable.

8. The valve assembly of claim 1 wherein the tubular member is configured to resiliently expand.

9. The valve assembly of claim 1, further comprising a rigid housing, wherein the tubular member, the first filament, and the second filament are positioned within the housing, and wherein the actuators are movably coupled to the housing.

10. The valve assembly of claim 1 wherein the actuators are depressed toward one another in the second position, and wherein the actuators are moved away from one another in the first position.

11. The valve assembly of claim 1 wherein, in the second position, the tubular member has a diameter of at least 14 French.

12. The valve assembly of claim 1 wherein, in the second position, the tubular member has a diameter of at least 16 French.

13. The valve assembly of claim 1 wherein, in the second position, the tubular member has a diameter of at least 20 French.

14. The valve assembly of claim 1 wherein, in the second position, the tubular member has a diameter of at least 24 French.

15. A valve assembly, comprising:

a tubular member defining a lumen, wherein the tubular member is elastically deformable from a first position in which the lumen is constricted to a second position in which the lumen is at least partially open;

a first actuator;

a second actuator;

a first filament configured in a first loop completely around the tubular member and having a first portion extending from the first loop toward the first actuator and a second portion extending from the first loop toward the second actuator; and

a second filament configured in a second loop completely around the tubular member and having a first portion extending from the second loop toward the first actuator and a second portion extending from the second loop toward the second actuator;

wherein—

the first actuator and the second actuator are biased away from one another to elastically deform the tubular member to the first position by (a) increasing a tension in the first filament to decrease a dimension of the first loop and (b) increasing a tension in the second filament to decrease a dimension of the second loop; and

the first actuator and the second actuator are movable toward one another to permit the tubular member to return to the second position by (a) decreasing the tension in the first filament and (b) decreasing the tension in the second filament.

16. The valve assembly of claim 15 wherein the first actuator and the second actuator each comprise a button.

17. The valve assembly of claim 15 wherein the first filament is flexible, and wherein the second filament is flexible.

18. The valve assembly of claim 15 wherein the first portion of first filament is directly attached to the first actuator, wherein the second portion of the first filament is directly attached to the second actuator, wherein the first portion of the second filament is directly attached to the first actuator, and wherein the second portion of the second filament is directly attached to the second actuator.

19. The valve assembly of claim 15 wherein the tubular member extends along a longitudinal axis, wherein the first

portion of the first filament extends toward the first actuator along a first axis extending generally orthogonal to the longitudinal axis proximate the tubular member, wherein the second portion of the first filament extends toward the second actuator along a second axis extending generally orthogonal to the longitudinal axis proximate the tubular member, wherein the first portion of the second filament extends toward the first actuator along a third axis extending generally orthogonal to the longitudinal axis proximate the tubular member, wherein the second portion of the second filament extends toward the second actuator along a fourth axis extending generally orthogonal to the longitudinal axis proximate the tubular member, wherein the second axis is positioned between the first axis and the fourth axis, and wherein the fourth axis is positioned between the second axis and the third axis.

20. The valve assembly of claim 15 wherein, in the second position, the tubular member has a diameter of at least 16 French.

21. The valve assembly of claim 15 wherein, in the second position, the tubular member has a diameter of at least 20 French.

22. The valve assembly of claim 15 wherein, in the second position, the tubular member has a diameter of at least 24 French.

23. A valve assembly, comprising:

a tubular member defining a lumen;

a first filament extending in a first loop around the tubular member;

a second filament extending in a second loop around the tubular member; and

a pair of actuators biased to circumferentially constrict the first loop and the second loop to elastically deform the tubular member to a first position in which the lumen is constricted, wherein at least one the actuators is movable to decrease a level of tension in the first filament and a level of tension in the second filament to permit the tubular member to expand against the first loop and the second loop to a second position in which the lumen of the tubular member is at least partially open.

24. The valve assembly of claim 23 wherein the actuators each comprise a button.

25. The valve assembly of claim 23 wherein the first filament includes a first portion operably coupled to a first one of the actuators and a second portion operably coupled to a second one of the actuators, and wherein the second filament includes a first portion operably coupled to the first one of the actuators and a second portion operably coupled to the second one of the actuators.

26. The valve assembly of claim 25 wherein the first portion of first filament is directly attached to the first one of the actuators, wherein the second portion of the first filament is directly attached to the second one of the actuators, wherein the first portion of the second filament is directly attached to the first one of the actuators, and wherein the second portion of the second filament is directly attached to the second one of the actuators.

27. The valve assembly of claim 23 wherein the first filament is flexible, and wherein the second filament is flexible.

28. The valve assembly of claim 23 wherein, in the second position, the tubular member has a diameter of at least 16 French.

29. The valve assembly of claim 23 wherein, in the second position, the tubular member has a diameter of at least 20 French.

25

30. The valve assembly of claim **23** wherein, in the second position, the tubular member has a diameter of at least 24 French.

* * * * *

26