



(19) **United States**

(12) **Patent Application Publication**  
**Credelle**

(10) **Pub. No.: US 2003/0128179 A1**

(43) **Pub. Date: Jul. 10, 2003**

(54) **COLOR FLAT PANEL DISPLAY SUB-PIXEL ARRANGEMENTS AND LAYOUTS FOR SUB-PIXEL RENDERING WITH SPLIT BLUE SUB-PIXELS**

**Related U.S. Application Data**

(60) Provisional application No. 60/346,738, filed on Jan. 7, 2002.

**Publication Classification**

(51) **Int. Cl.<sup>7</sup> .....** G09G 5/02  
(52) **U.S. Cl. ....** 345/88

(76) **Inventor: Thomas Lloyd Credelle, Morgan Hill, CA (US)**

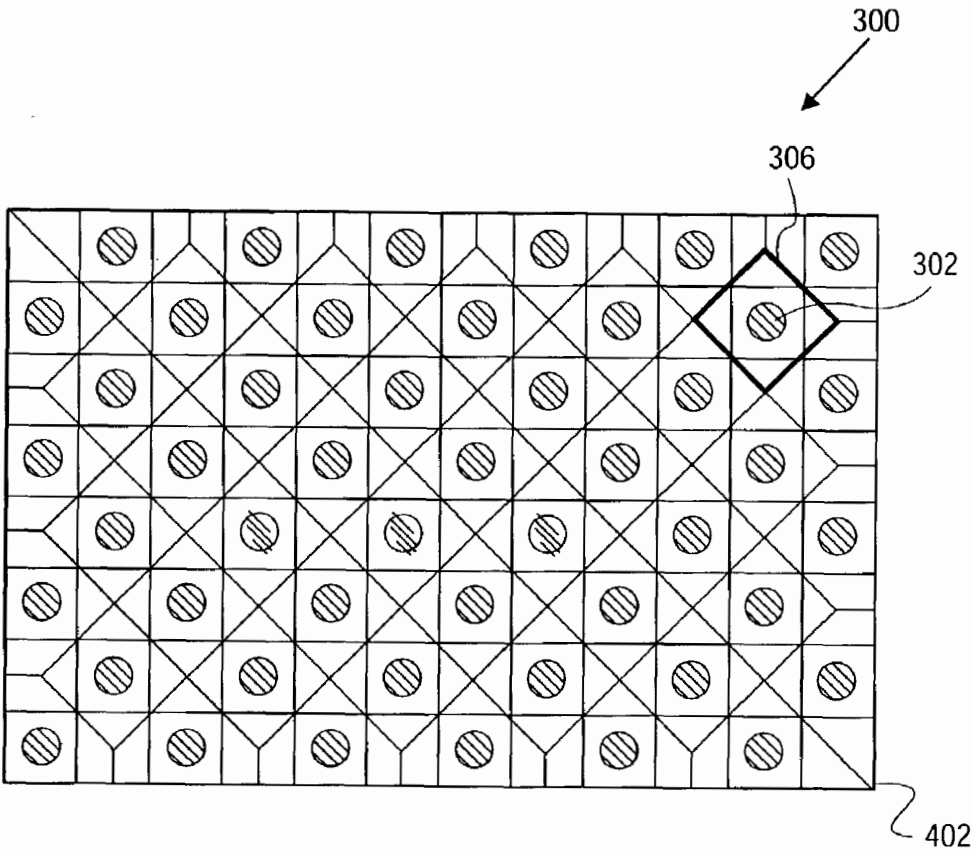
**Correspondence Address:**  
**Finnegan, Henderson, Farabow,**  
**Garrett & Dunner, L.L.P.**  
**1300 I Street, N.W.**  
**Washington, DC 20005-3315 (US)**

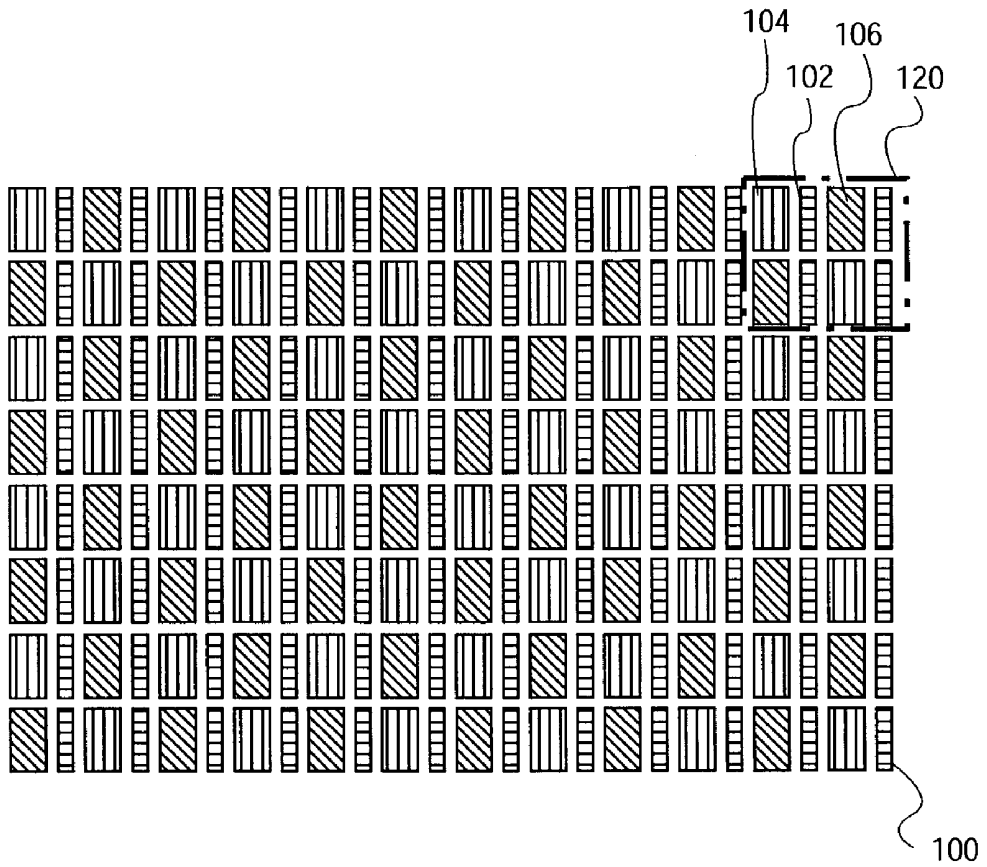
(57) **ABSTRACT**

Various embodiments of a sub-pixel octal grouping are disclosed. The octal grouping may comprise three-color (red, green and blue) sub-pixels with blue colored subpixel comprising twice the number of positions within the octal sub-pixel grouping as the red and green colored sub-pixels. Various embodiments for performing sub-pixel rendering on the sub-pixel groupings are disclosed.

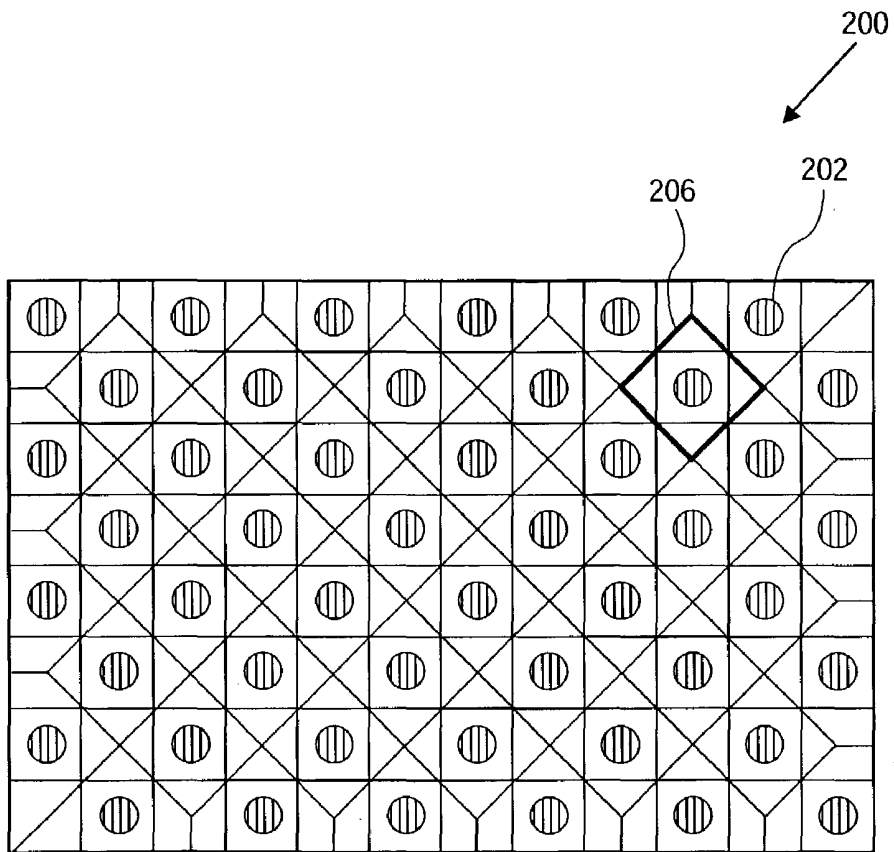
(21) **Appl. No.: 10/278,352**

(22) **Filed: Oct. 22, 2002**

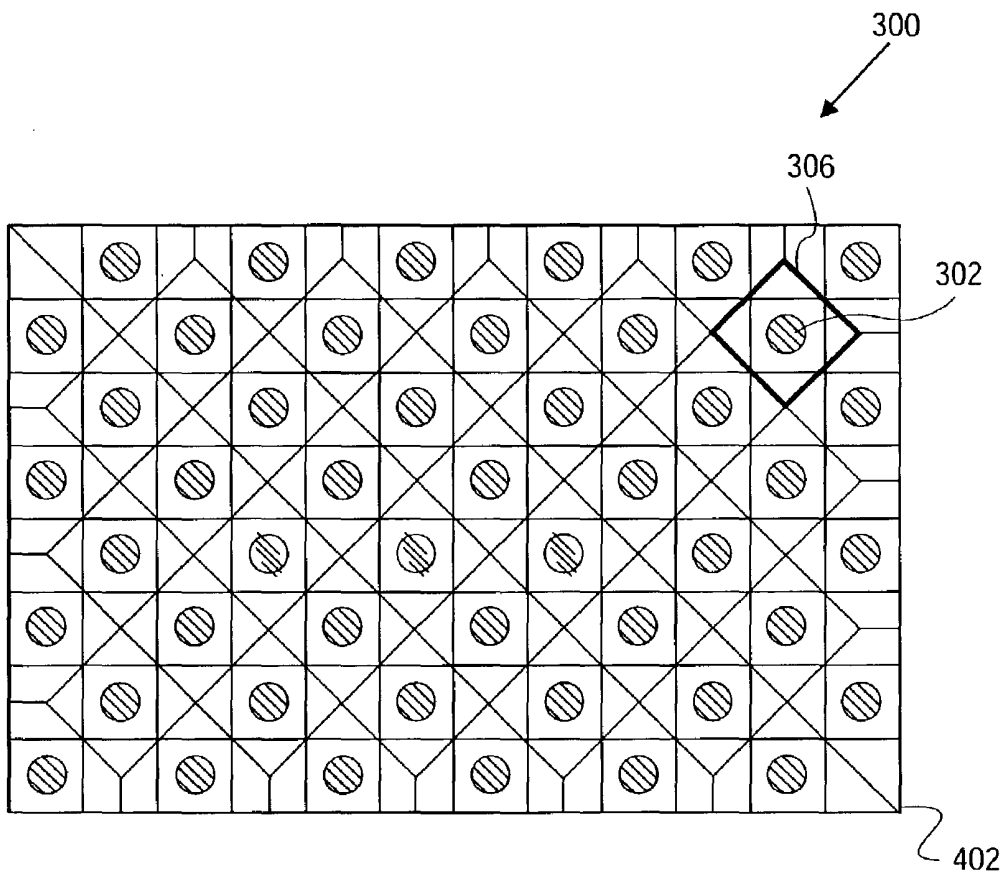




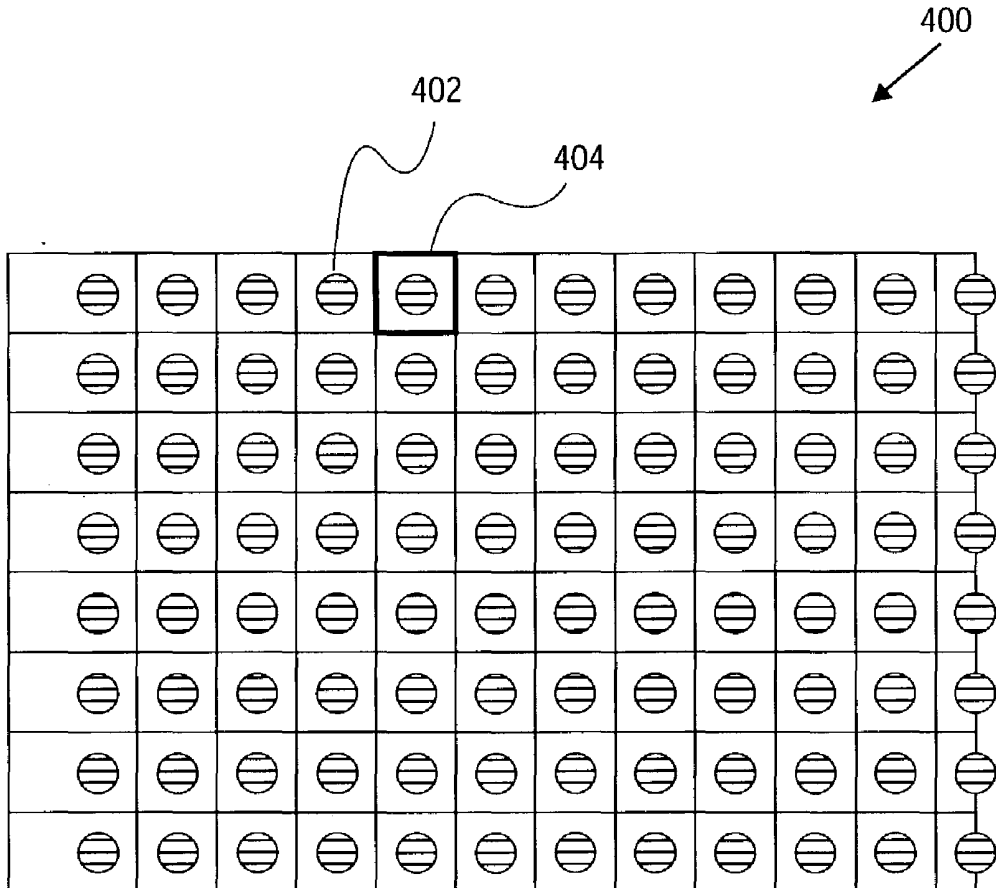
**FIG. 1**



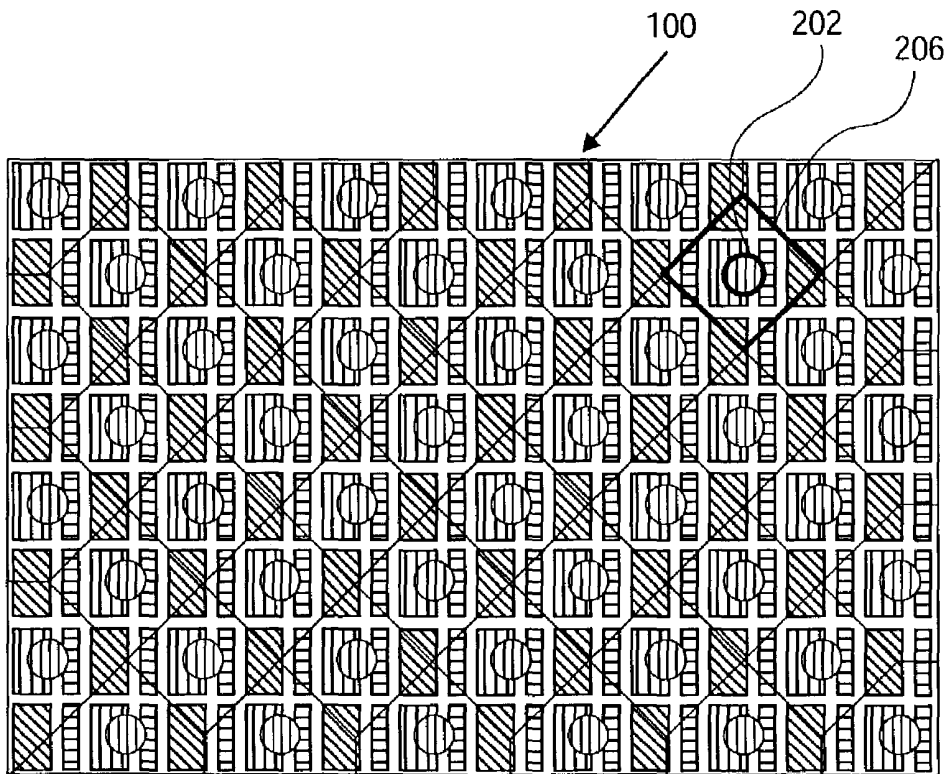
**FIG. 2**



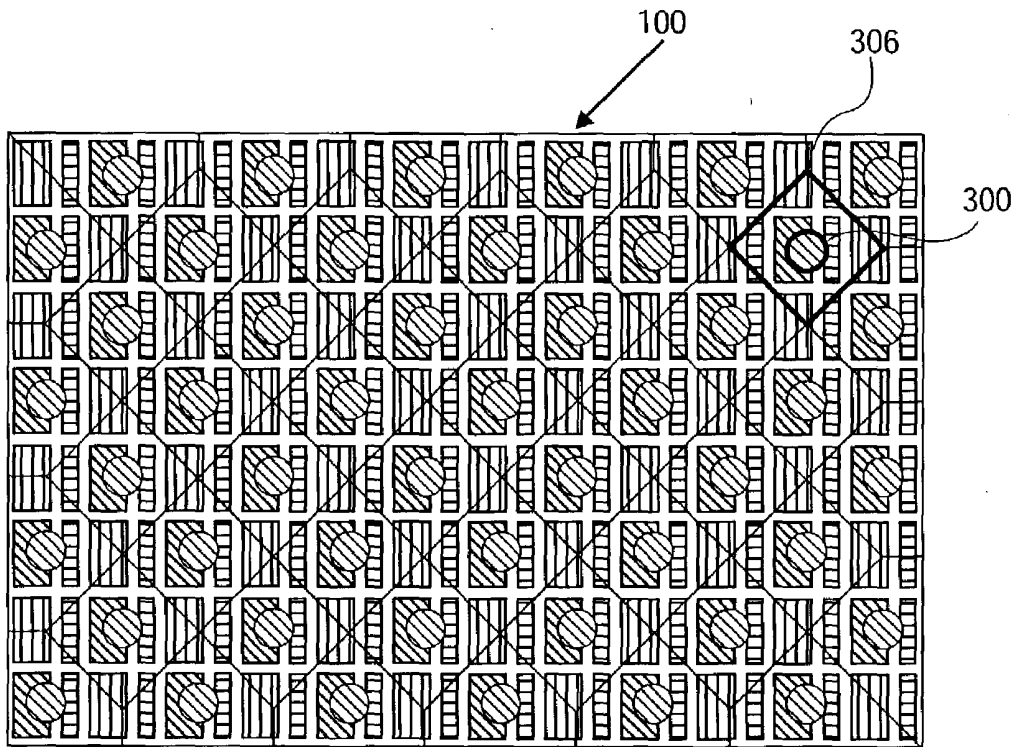
**FIG. 3**



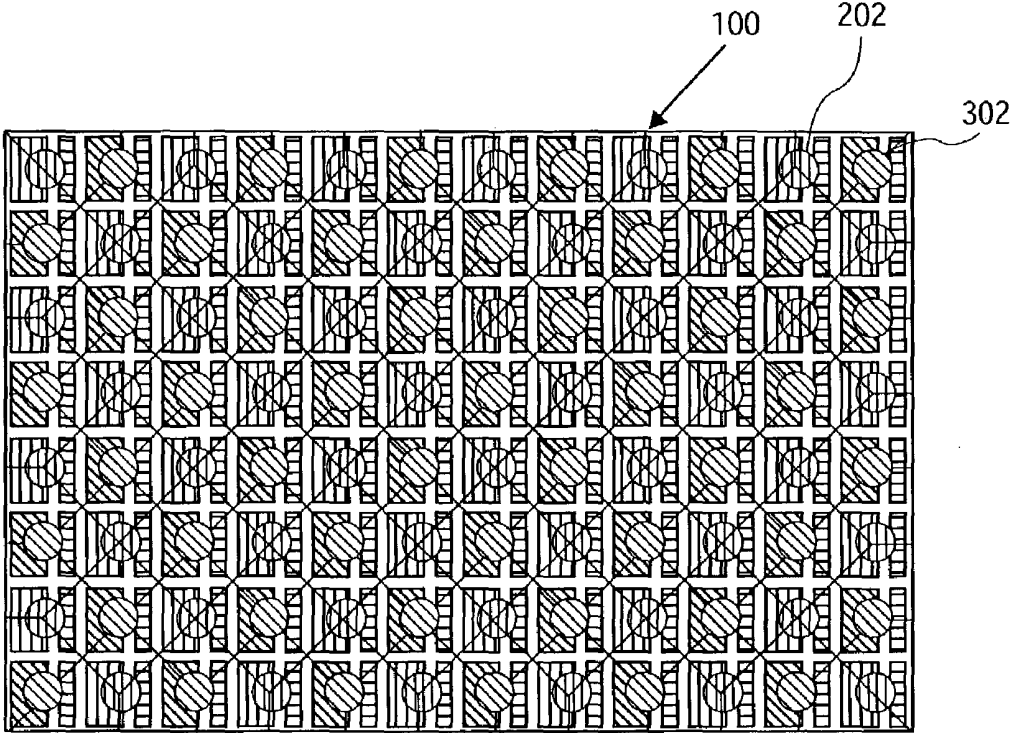
**FIG. 4**



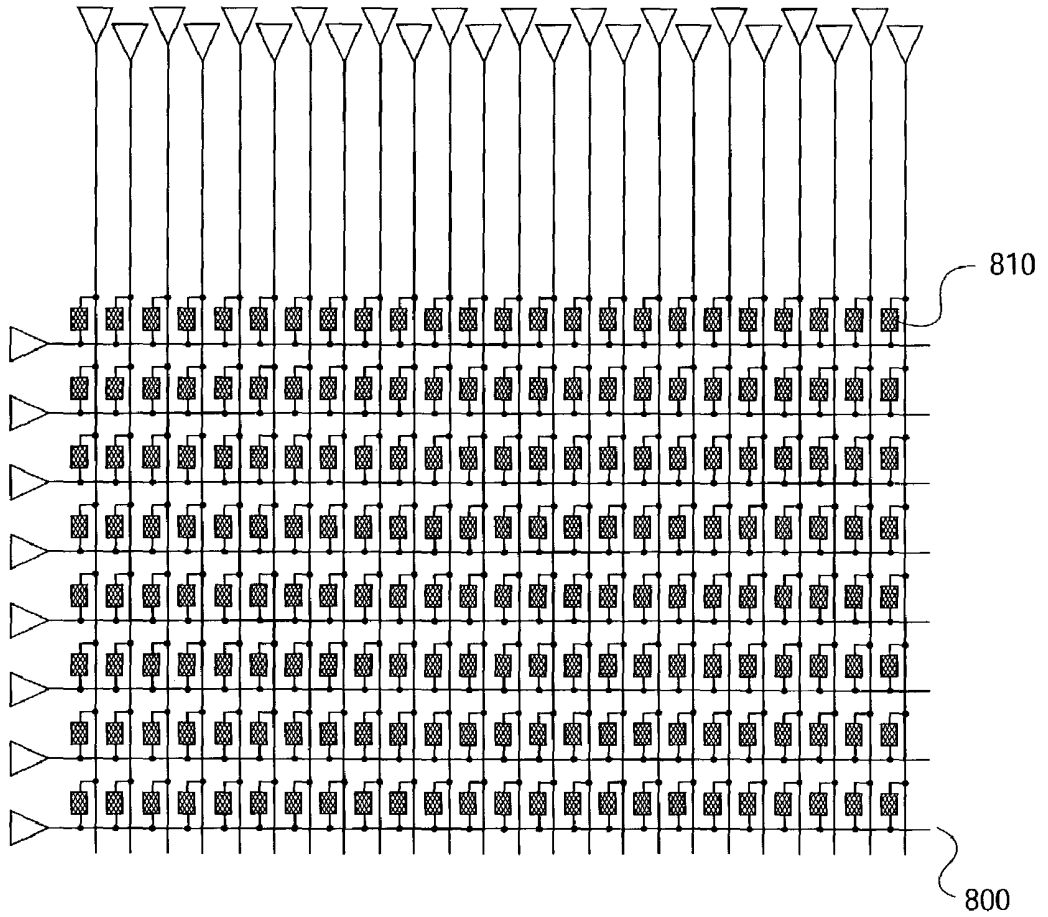
**FIG. 5**



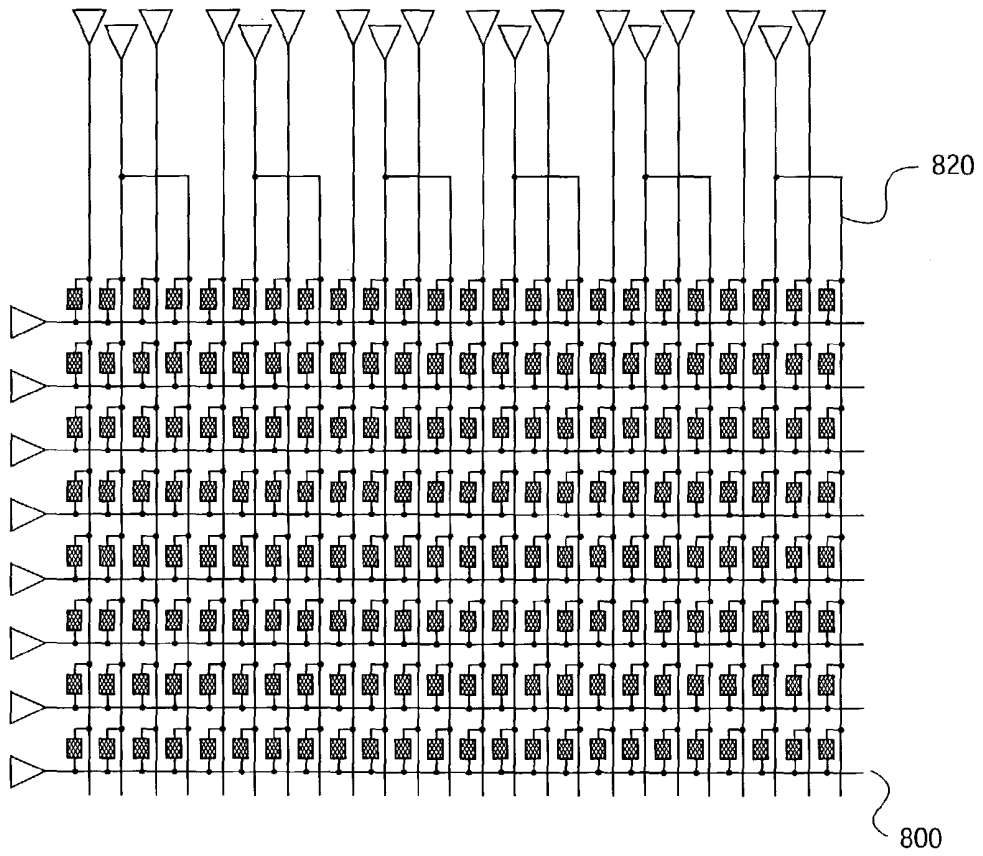
**FIG. 6**



**FIG. 7**



**FIG. 8A**



**FIG. 8B**

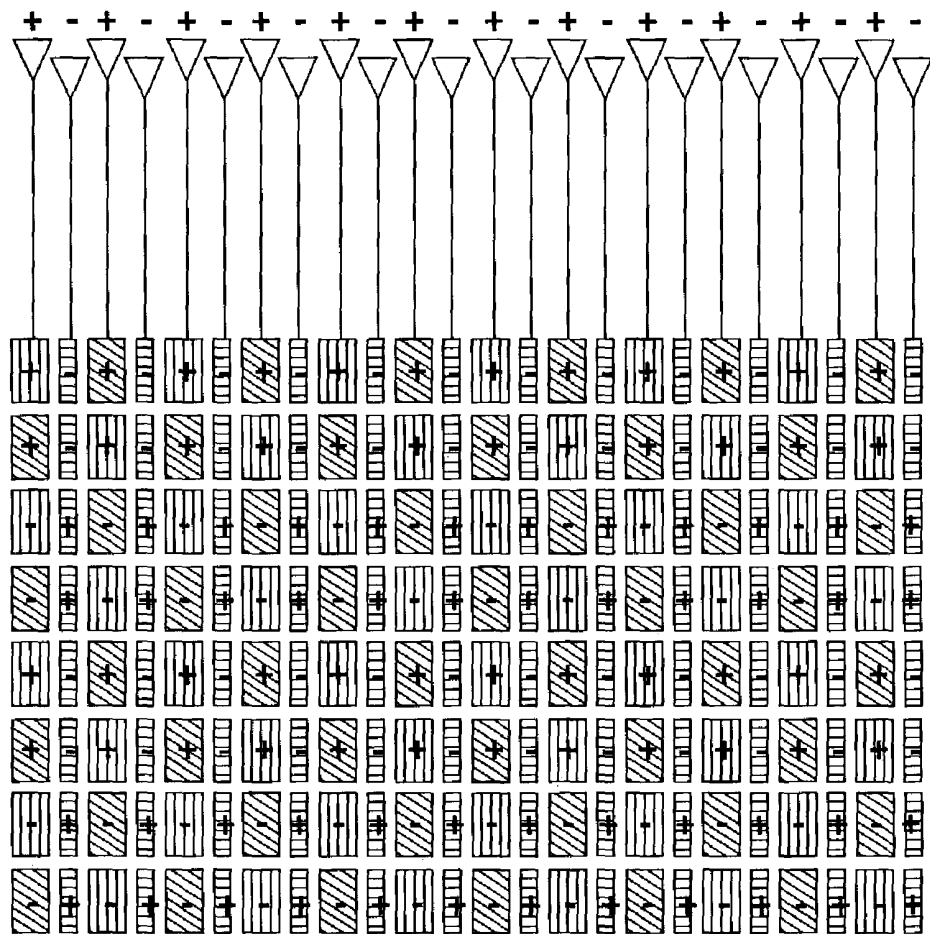


FIG. 9

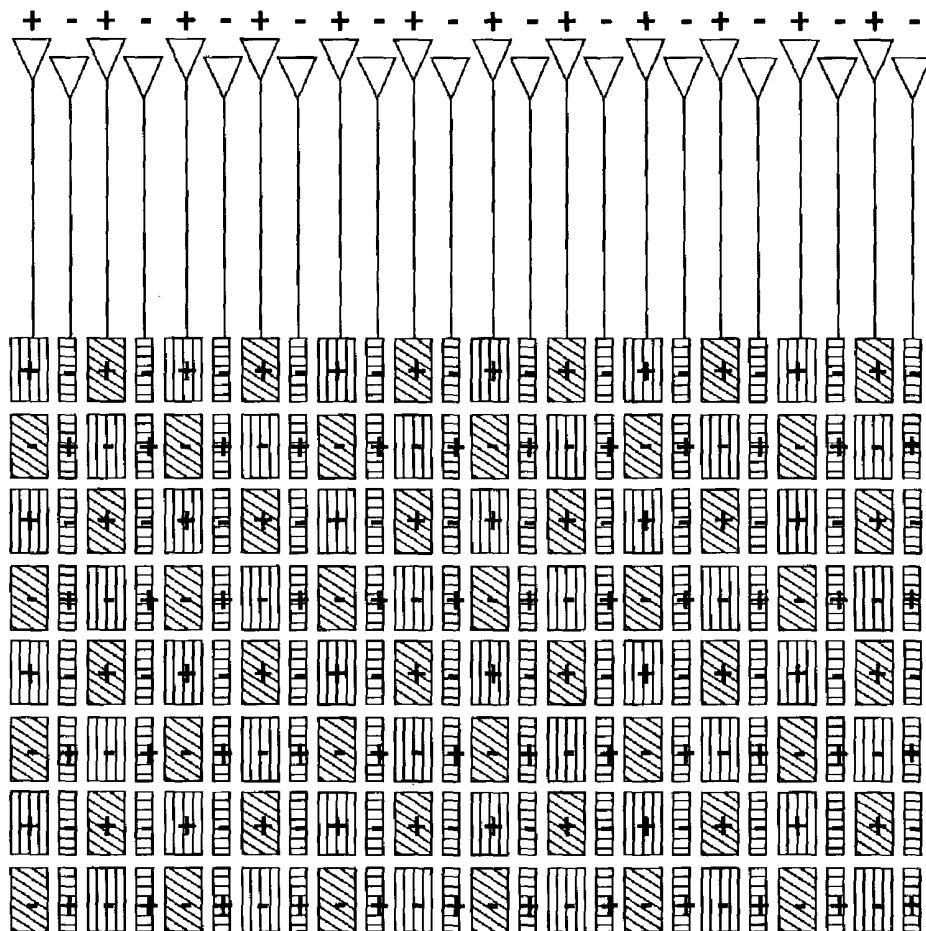
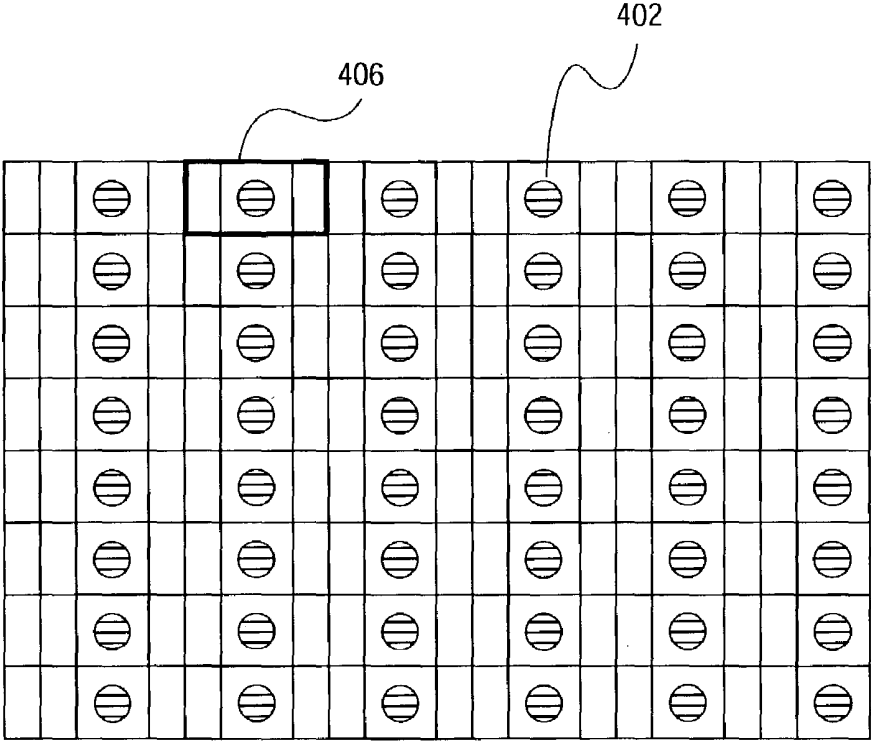
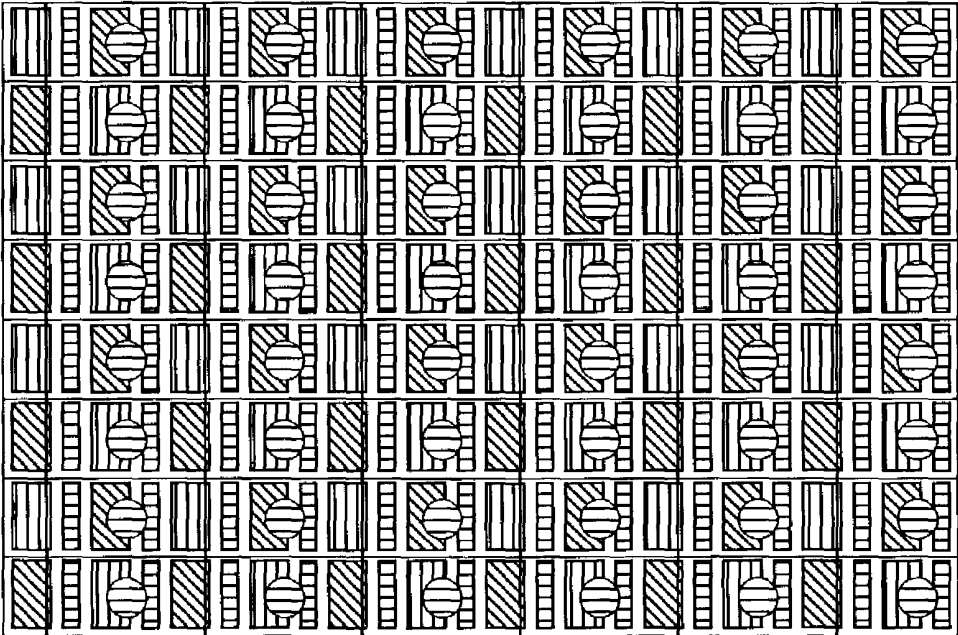


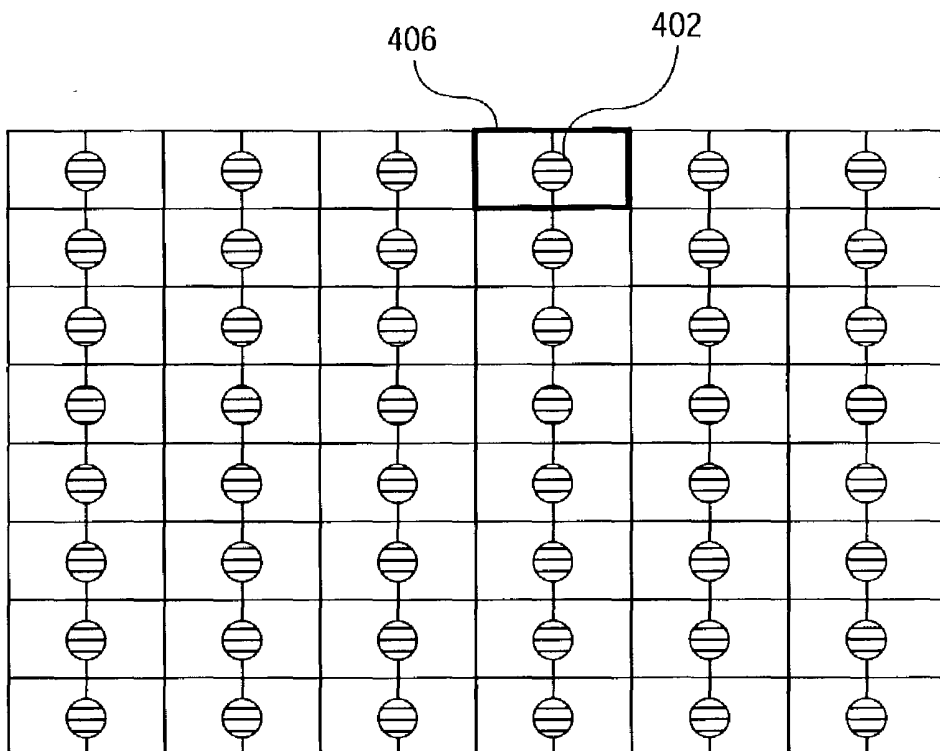
FIG. 10



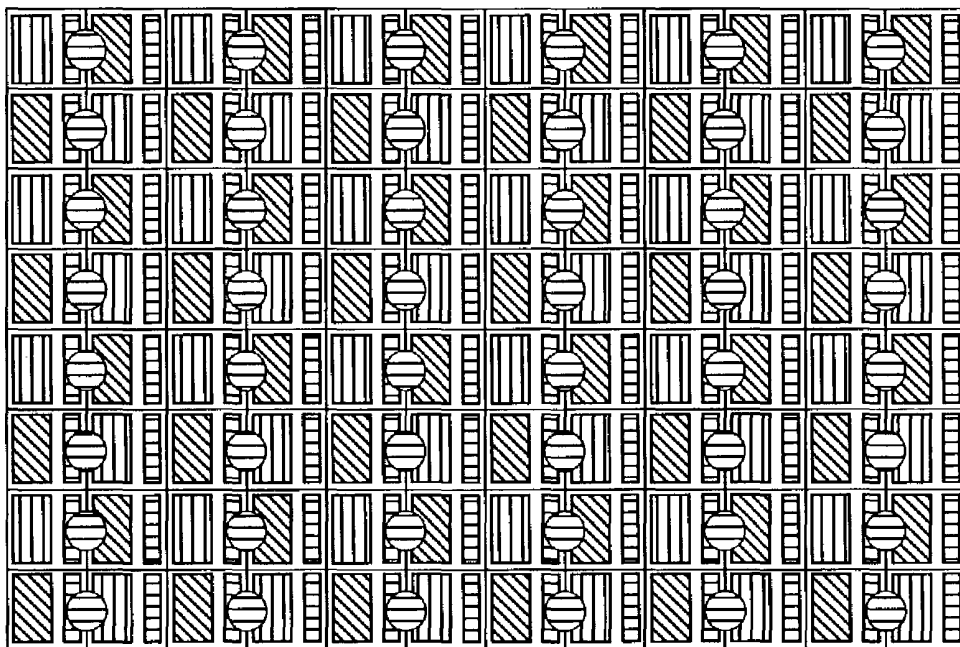
**FIG. 11**



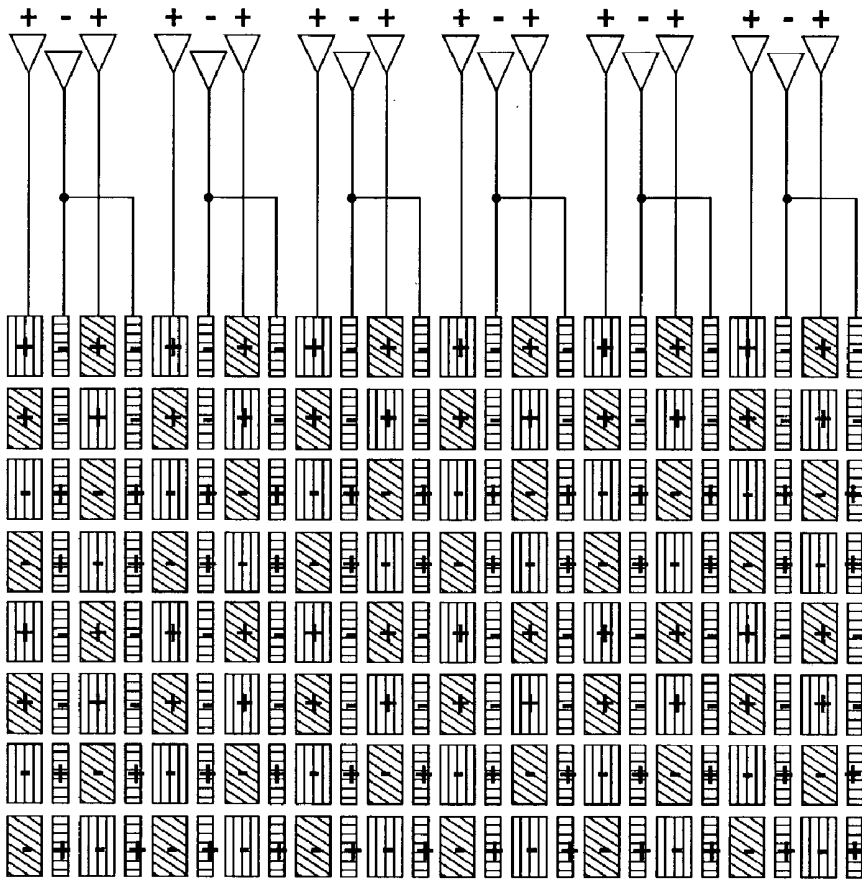
**FIG. 12**



**FIG. 13**



**FIG. 14**



**FIG. 15**

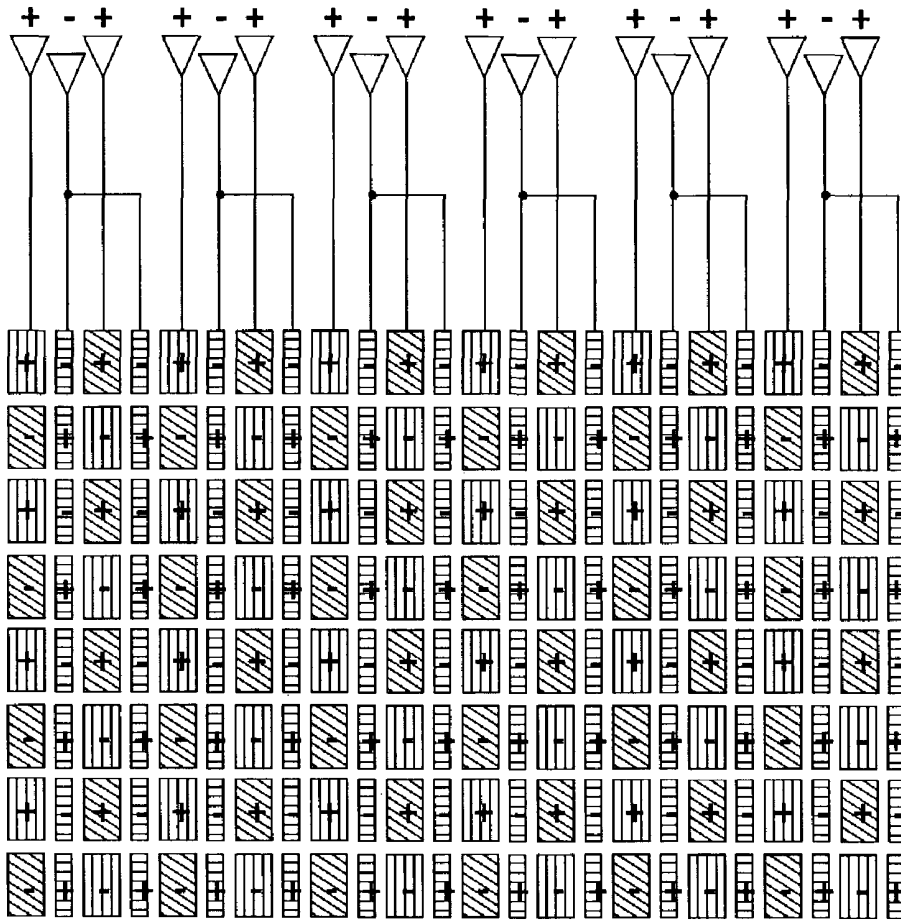


FIG. 16

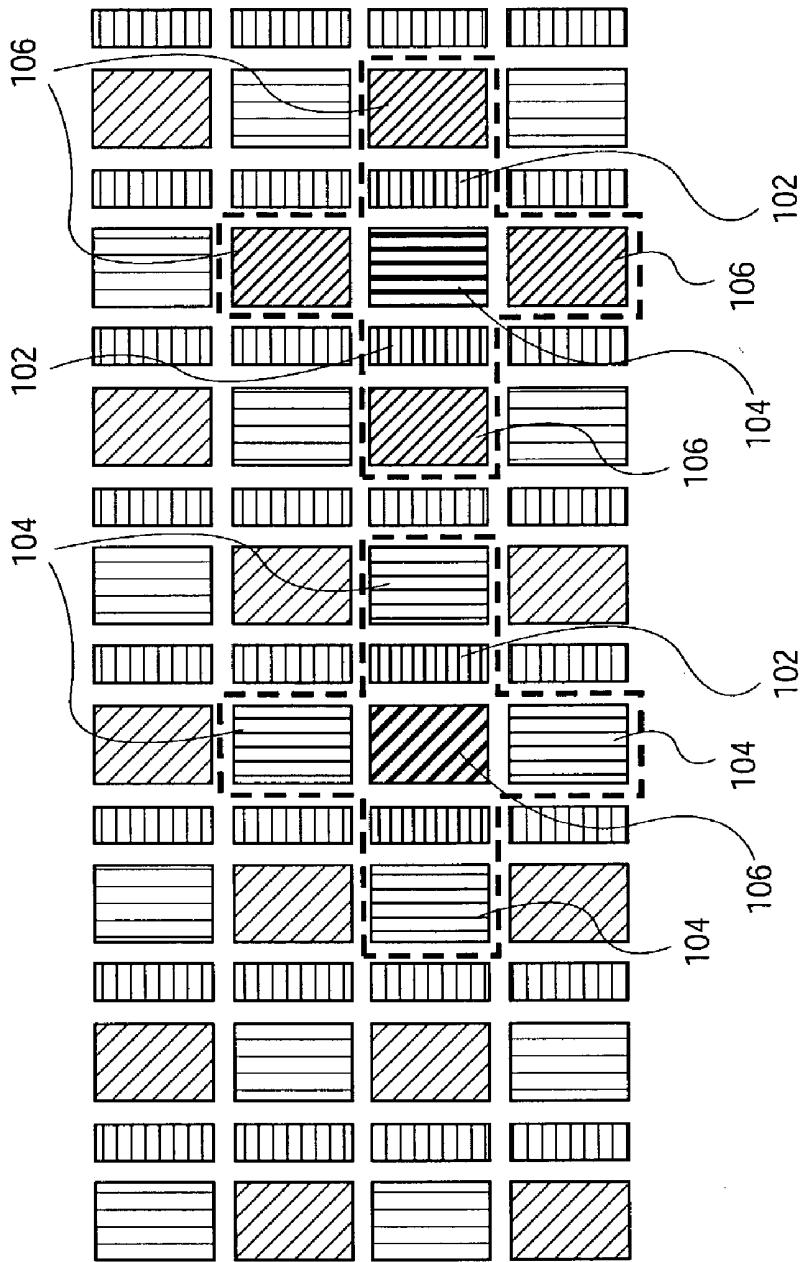
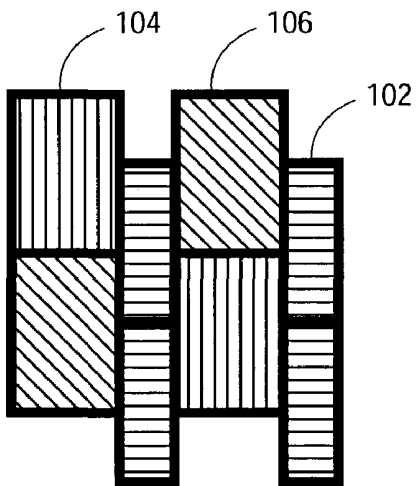
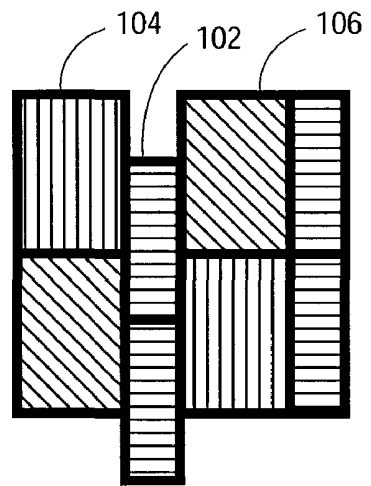


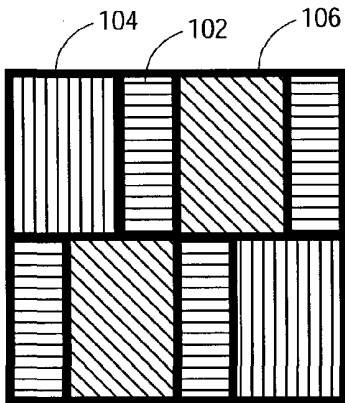
FIG. 17



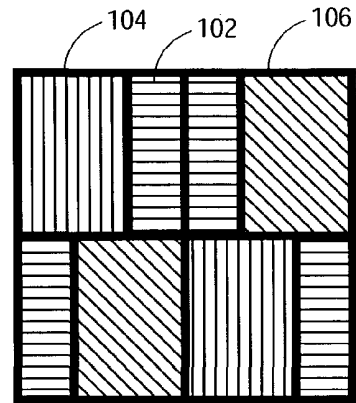
**FIG. 18A**



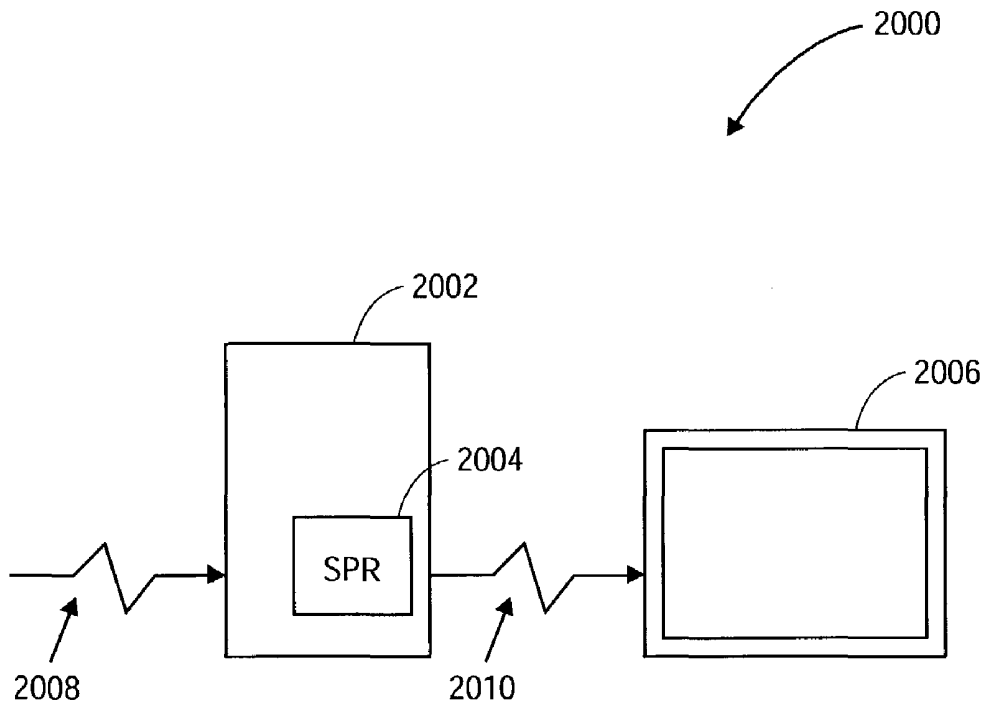
**FIG. 18B**



**FIG. 19A**



**FIG. 19B**



**FIG. 20**

**COLOR FLAT PANEL DISPLAY SUB-PIXEL  
ARRANGEMENTS AND LAYOUTS FOR  
SUB-PIXEL RENDERING WITH SPLIT BLUE  
SUB-PIXELS**

RELATED APPLICATIONS

[0001] This application claims priority to U.S. Provisional Patent Application No. 60/346,738 (“the ’738 provisional application”), entitled “ARRANGEMENT OF SUBPIXELS WITH DOUBLE BLUE STRIPES,” filed on Jan. 7, 2002, which is hereby incorporated herein by reference.

[0002] This application is also related to U.S. patent application Ser. No. \_\_\_\_\_, entitled “IMPROVEMENTS TO COLOR FLAT PANEL DISPLAY SUB-PIXEL ARRANGEMENTS AND LAYOUTS WITH REDUCED BLUE LUMINANCE WELL VISIBILITY,” filed on \_\_\_\_\_; U.S. patent application Ser. No. \_\_\_\_\_, entitled “COLOR DISPLAY HAVING HORIZONTAL SUB-PIXEL ARRANGEMENTS AND LAYOUTS,” filed on \_\_\_\_\_; and U.S. patent application Ser. No. \_\_\_\_\_, entitled “IMPROVEMENTS TO COLOR FLAT PANEL DISPLAY SUB-PIXEL ARRANGEMENTS AND LAYOUTS FOR SUB-PIXEL RENDERING WITH INCREASED MODULATION TRANSFER FUNCTION RESPONSE,” filed on \_\_\_\_\_, which are all hereby incorporated herein by reference and commonly owned by the same assignee of this application.

BACKGROUND

[0003] The present application relates to improvements to display layouts, and, more particularly, to improved color pixel arrangements, means of addressing used in displays, and to data format conversion methods for these displays.

[0004] Full color perception is produced in the eye by three-color receptor nerve cell types called cones. The three types are sensitive to different wavelengths of light: long, medium, and short (“red”, “green”, and “blue”, respectively). The relative density of the three differs significantly from one another. There are slightly more red receptors than green receptors. There are very few blue receptors compared to red or green receptors.

[0005] The human vision system processes the information detected by the eye in several perceptual channels: luminance, chrominance, and motion. Motion is only important for flicker threshold to the imaging system designer. The luminance channel takes the input from only the red and green receptors. In other words, the luminance channel is “color blind.” It processes the information in such a manner that the contrast of edges is enhanced. The chrominance channel does not have edge contrast enhancement. Since the luminance channel uses and enhances every red and green receptor, the resolution of the luminance channel is several times higher than the chrominance channels. Consequently, the blue receptor contribution to luminance perception is negligible. The luminance channel thus acts as a resolution band pass filter. Its peak response is at 35 cycles per degree (cycles/°). It limits the response at 0 cycles/° and at 50 cycles/° in the horizontal and vertical axis. This means that the luminance channel can only tell the relative brightness between two areas within the field of view. It cannot tell the absolute brightness. Further, if any detail is finer than 50 cycles/°, it simply blends together. The limit in the horizontal axis is slightly higher than the vertical axis. The limit in the diagonal axes is significantly lower.

[0006] The chrominance channel is further subdivided into two sub-channels, to allow us to see full color. These channels are quite different from the luminance channel, acting as low pass filters. One can always tell what color an object is, no matter how big it is in our field of view. The red/green chrominance sub-channel resolution limit is at 8 cycles/°, while the yellow/blue chrominance sub-channel resolution limit is at 4 cycles/°. Thus, the error introduced by lowering the red/green resolution or the yellow/blue resolution by one octave will be barely noticeable by the most perceptive viewer, if at all, as experiments at Xerox and NASA, Ames Research Center (see, e.g., R. Martin, J. Gille, J. Larimer, Detectability of Reduced Blue Pixel Count in Projection Displays, SID Digest 1993) have demonstrated.

[0007] The luminance channel determines image details by analyzing the spatial frequency Fourier transform components. From signal theory, any given signal can be represented as the summation of a series of sine waves of varying amplitude and frequency. The process of teasing out, mathematically, these sine-wave-components of a given signal is called a Fourier Transform. The human vision system responds to these sine-wave-components in the two-dimensional image signal.

[0008] Color perception is influenced by a process called “assimilation” or the Von Bezold color blending effect. This is what allows separate color pixels (also known as sub-pixels or emitters) of a display to be perceived as a mixed color. This blending effect happens over a given angular distance in the field of view. Because of the relatively scarce blue receptors, this blending happens over a greater angle for blue than for red or green. This distance is approximately 0.25° for blue, while for red or green it is approximately 0.12°. At a viewing distance of twelve inches, 0.25° subtends 50 mils (1,270  $\mu$ ) on a display. Thus, if the blue pixel pitch is less than half (625  $\mu$ ) of this blending pitch, the colors will blend without loss of picture quality. This blending effect is directly related to the chrominance sub-channel resolution limits described above. Below the resolution limit, one sees separate colors, above the resolution limit, one sees the combined color.

BRIEF DESCRIPTION OF THE DRAWINGS

[0009] The accompanying drawings, which are incorporated in, and constitute a part of this specification illustrate various implementations and embodiments.

[0010] FIG. 1 shows an arrangement of sub-pixel emitters comprising three colors—red, green, and blue—in groupings that create a larger rectilinearly repeating cell group of eight sub-pixels wherein the blue sub-pixels are “split”.

[0011] FIGS. 2, 3 and 4 illustrate one embodiment of red, green, and blue resample area arrays for the red, green and blue color planes respectively to match the sub-pixel arrangement of FIG. 1.

[0012] FIGS. 5 and 6 illustrate the red and green resample area arrays of FIGS. 2 and 3 overlaid on the sub-pixel arrangement of FIG. 1 respectively.

[0013] FIG. 7 illustrates one particular inter-color-plane-phase relationship between the red and green color resample areas overlaid on the sub-pixel arrangement of FIG. 1.

[0014] FIGS. 8A and 8B illustrate two possible schematics for a driver arrangement for the arrangement of color emitter sub-pixels in FIG. 1.

[0015] FIGS. 9 and 10 show two “dot inversion” schemes—commonly known as “2×1” and “1×1”, respectively—matching FIG. 8A’s schematic.

[0016] FIGS. 11 and 13 depict alternative blue color plane resample area arrays to replace the one shown in FIG. 4.

[0017] FIGS. 12 and 14 show how the respective blue color plane resample areas of FIGS. 11 and 13 would map onto the sub-pixel layout as shown in FIG. 1.

[0018] FIGS. 15 and 16 show two “dot inversion” schemes—commonly known as “2×1” and “1×1”, respectively—matching FIG. 8B’s schematic.

[0019] FIG. 17 illustrates the results of turning on two full color incoming data pixels.

[0020] FIGS. 18A and 18B show other embodiments of the octal subpixel arrangement with various vertical displacements of the subpixels.

[0021] FIGS. 19A and 19B show yet other embodiments of the octal subpixel arrangement of various displacements of the split majority subpixel within the subpixel grouping.

[0022] FIG. 20 depicts a system incorporating sub-pixel rendering techniques suitable to drive a panel made in accordance with the various embodiments described herein.

#### DETAILED DESCRIPTION

[0023] Reference will now be made in detail to various implementations and embodiments, examples of which are illustrated in the accompanying drawings. Wherever possible, the same reference numbers will be used throughout the drawings to refer to the same or like parts.

[0024] In FIG. 1, in the arrangement of sub-pixel emitters 100, there are three-color emitters in groupings 120 that create a larger rectilinearly repeating cell group of eight sub-pixels. This layout was introduced in the the ’738 provisional application and included herein by reference. Grouping 120 comprises red sub-pixels 104, green sub-pixels 106 and blue sub-pixels 102. As may be seen, blue sub-pixels 102 are “split”—i.e. having a smaller width along the horizontal axis than either red or green sub-pixels but doubled in number per grouping or repeat cell. Such a “split” sub-pixel can refer to a sub-pixel having a smaller area than a non-split sub-pixel. Splitting the blue sub-pixels helps in breaking up the noticeable effect of visible vertical blue stripes down the display, as further discussed in U.S. patent application Ser. No. \_\_\_\_\_ (“the \_\_\_\_\_ application”), entitled “IMPROVEMENTS TO COLOR FLAT PANEL DISPLAY SUBPIXEL ARRANGEMENTS AND LAYOUTS WITH REDUCED BLUE LUMINANCE WELL VISIBILITY,” filed on \_\_\_\_\_, incorporated by reference.

[0025] As may additionally be seen in FIG. 1, the red and the green sub-pixels are placed upon a “checkerboard” pattern with the repeat cell itself. As discussed further in the \_\_\_\_\_ application, it may be desirable to alter the repeat cell grouping 120 color assignments to have a split green sub-pixel in position of sub-pixels 102 and have the remaining red and blue sub-pixels form the checkerboard pattern. Likewise, it might be desirable to have the red sub-pixels split and the green and blue sub-pixels on a checkerboard pattern. The alternating “checkerboard” of emitters is similar to the red and green “checkerboard” that was disclosed in co-pending and comonly assigned U.S. patent application Ser. No. 09/916,232, entitled “ARRANGEMENT OF

COLOR PIXELS FOR FULL COLOR IMAGING DEVICES WITH SIMPLIFIED ADDRESSING,” filed on Jul. 28, 2000, which is hereby incorporated herein by reference.

[0026] It should be appreciate that while FIG. 1 depicts the “split” blue subpixel as narrower than either the red or the green subpixels, another embodiment of the present invention employs blue subpixels of equal area dimensions to the red and green subpixels. To achieve a pleasing white point with all subpixels on in a logical pixel, the relative intensities of the red, green and blue emitters can be changed appropriately as discussed in co-pending and commonly assigned U.S. patent application Ser. No. 10/243,094, entitled “IMPROVED FOUR COLOR ARRANGEMENTS OF EMITTERS FOR SUBPIXEL RENDERING,” filed Sep. 13, 2002, which is hereby incorporated herein by reference.

[0027] As shown in FIG. 1, the subpixels appear to have a substantially rectangular appearance. It should be appreciated that other shapes to the subpixels are also possible and are contemplated within the scope of the present invention. For example, a multitude of other regular or irregular shapes for the subpixels are possible and are desirable if manufacturable. It suffices only that there is an octal grouping of colored subpixels in the fashion herein described that may be addressable for the purposes of subpixel rendering (SPR).

[0028] As subpixel shapes may vary under the scope of the present invention, so too may the exact positions of the subpixels be varied under the scope of the present invention. For example, FIGS. 18A and 18B depict a similar octal subpixel grouping wherein one or both of the majority stripes 102 are offset (relatively or otherwise) from the other subpixels 104 and 106. Other vertical offsets are also possible.

[0029] Other embodiments of the octal groupings are also possible. FIGS. 19A and 19B depict octal groupings wherein the majority subpixels 102 are interspersed within the checkerboard of subpixels 104 and 106. Other arrangements of majority subpixel placement within such a checkerboard are also possible and are contemplated within the scope of the present invention.

[0030] FIGS. 19A and 19B may have column electrodes that zig-zag across the display. Column driver savings should be one third when compared to the RGB stripe system with the same resolution and the number of subpixels are about two thirds of the number of subpixels when compared to the RGB stripe system.

[0031] Yet other embodiments of the present invention are possible. For example, the entire octal subpixel groupings may be rotated 90 degrees to reverse the roles of row and column driver connections to the grouping. Such a horizontal arrangement for subpixels is further disclosed in the co-pending and commonly assigned application entitled “COLOR DISPLAY HAVING HORIZONTAL SUB-PIXEL ARRANGEMENTS AND LAYOUTS,” incorporated by reference.

[0032] The alternating “checkerboard” of emitters is similar to the red and green “checkerboard” that was disclosed in co-pending U.S. patent application Ser. No. 09/916,232 (“the ’232 application”), entitled “ARRANGEMENT OF COLOR PIXELS FOR FULL COLOR IMAGING DEVICES WITH SIMPLIFIED ADDRESSING,” filed on Jul. 25, 2001 and hereby incorporated herein by reference.

[0033] With the display comprised substantially of repeat cell **120** having the blue sub-pixel split as sub-pixel **102**, it is possible to perform sub-pixel rendering upon this display using the area resampling techniques as described in U.S. Patent Application No. 10/150,355 (“the ’355 application”), entitled “METHODS AND SYSTEMS FOR SUB-PIXEL RENDERING WITH GAMMA ADJUSTMENT,” filed on May 17, 2002, which is hereby incorporated herein by reference and is commonly owned by the same assignee of this application. One such embodiment of area resampling is shown in FIGS. 2 through 7.

[0034] FIGS. 2, 3 and 4 illustrate red **200**, green **300**, and blue **400** resample area arrays for the red, green and blue color planes, respectively. It should be noted that each color resample area array **200**, **300**, and **400** comprises of resample areas **206**, **306** and **404** and that each resample area has an associated resample point **202**, **302** and **402**, respectively. The resample points **202**, **302**, and **402** match the relative positions of the red **104**, green **106** and blue **102** sub-pixel locations, respectively, within each color plane; but not necessarily their exact inter-color-plane-phase relationships. Any number of phase relationships are possible, a number of which have useful properties in given data format conversion cases.

[0035] FIGS. 5 and 6 illustrate the red and green resample area arrays of FIGS. 2 and 3 overlaid on the sub-pixel arrangement **100** of FIG. 1, respectively. FIG. 7 illustrates one particular inter-color-plane-phase relationship between the red and green color resample areas overlaid on the sub-pixel arrangement **100**. This particular intercolor-plane-phase relationship depicts converting the conventional fully converged square grid red-green-blue RGB format which is to be displayed “one-to-one” with the square blue **102** sub-pixel grid. In this inter-color-plane-phase relationship, the green **300**, blue **400**, and red **200** resample area arrays are positioned such that the red **202** and green **302** resample points overlap the blue **402** sample points. This treats the blue sub-pixels **102** as though they lay on top of, or intimately associated with, the red **104** and green **106** sub-pixel checkerboard.

[0036] FIGS. 11 and 13 depict alternative blue color plane resample area arrays to replace the one shown in FIG. 4. FIGS. 12 and 14 show how these respective blue color plane resample area would map onto the sub-pixel layout as shown in FIG. 1. FIGS. 11 and 13 depict two different embodiments of resample areas **406** for blue with the phase shift shown. It should be appreciated that other phase shifts suffice for the purposes of the present invention. Additionally, other resample areas for the blue pixel data could be employed without departing from the scope of the present invention.

[0037] These Figures are merely illustrative and only serve to provide an understanding of the relationship between the resample points, reconstruction points, resample areas, and sub-pixel locations for this embodiment.

[0038] The sub-pixel rendering techniques as described in the ’355 patent application can be used to convert the incoming data format to that suitable for the display. In such a case, the method proceeds as follows: (1) determining implied sample areas for each data point of incoming three-color pixel data; (2) determining the resample area for each color sub-pixel in the display; (3) forming a set of coefficients for each said resample area, the coefficients comprising fractions whose denominators are a function of

the resample area and the numerators are a function of an area of each said implied sample areas that may partially overlap the resample areas; (4) multiplying the incoming pixel data for each implied sample area by the coefficient resulting in a product; (5) adding each product to obtain luminance values for each resample area.

[0039] Other sub-pixel rendering techniques are possible to employ with the various sub-pixel arrangements as disclosed herein. For example, the techniques known as “adaptive filtering” may be employed in the same fashion as described in U.S. patent application Ser. No. 10/215,843, entitled “METHODS AND SYSTEMS FOR SUB-PIXEL RENDERING WITH ADAPTIVE FILTERING,” filed on Aug. 8, 2002, which is hereby incorporated herein by reference and commonly owned by the same assignee of this application. Adaptive filtering can be adopted so as not to require a 3x3 sample of input data, which uses a minimum of two lines of memory. The test may be based on a smaller sample of input data, for example 1x3 or 1x2 matrices. The input data is sampled to test for vertical or diagonal lines, dots and edges, or other high contrast features and then actions are taken, depending on the outcome of the tests.

[0040] Test masks may be used and compared to the image data to see if an edge is detected; if detected then take an appropriate action to the red and/or blue data—e.g. apply gamma or apply a new value or different filter coefficient. Otherwise, if no feature is detected, then no action may be taken.

[0041] FIG. 17 illustrates the results of turning on two full color incoming data pixels. The two pixels are converted to two clusters of sub-pixels, called “logical pixels”, turned on at varying amplitudes. The logical pixel on the left is centered on or near a green sub-pixel **106**. The logical pixel on the right is centered on or near a red sub-pixel **104**. In both logical pixels, the various sub-pixels are turned on to the appropriate illumination such that a pleasing white color is formed and centered on the green and red sub-pixels, respectively.

[0042] FIGS. 8A and 8B illustrate two possible schematics for a driver arrangement **800** for the arrangement of color emitter sub-pixels in FIG. 1. FIG. 8A shows a one to one correspondence of column drivers to columns in the display; however, with the split blue sub-pixels, it may be desirable to tie adjacent columns of split blue sub-pixels via connections **820**. As may be seen in FIG. 8B, this scheme has the advantage of saving on the number of column drivers.

[0043] For convenience, these examples given have the same number of sub-pixels illustrated as FIG. 1. These drive arrangements may be used for a number of display technologies, as the blocks **810** may represent one or several electrical components. They may represent the capacitive display cell element for passively addressed Liquid Crystal Display (LCD), or ElectroLuminescent (EL) Display. It may represent the gaseous discharge element in a Plasma Display Panel (PDP). It may represent the semiconductor diode element of a passively Inorganic Light Emitting Diode or an Organic Light Emitting Diode Display. It may represent the transistor, storage capacitor, and capacitive cell element of an Active Matrix Liquid Crystal Display (AMLCD). It may represent the multi-transistor, storage capacitor, and light emitting element of an Active Matrix Organic Light Emitting Diode Display (AMOLED). It may represent, in general, the color sub-pixel and its associated electronic elements found in other known or yet to be invented display technologies.

[0044] Known drive timing and methods may be used for N×M drive matrices as those shown. However, there may be modifications needed due to the specific color assignments, particularly any checkerboard across the panel or color alternations within a single column. For example, the technique known in the art as Multi-Line Addressing for passive LCD may be modified such that groupings of rows are restricted to odd and even row combinations. This will reduce potential color cross talk since, within a column with two alternating color sub-pixels, only one color will be addressed at a time.

[0045] Inversion schemes, switching the electrical field polarity across the display cell to provide a time averaged zero net field and ion current across the cell can be used to the above unique sub-pixel arrangements. FIGS. 9 and 10 (matching FIG. 8A's schematic) and FIGS. 15 and 16 (matching FIG. 8B's schematic) show two "dot inversion" schemes—referred to as "2×1" and "1×1", respectively—on Active Matrix Liquid Crystal Displays, both of which will perform satisfactorily. The scheme shown on FIGS. 9 and 15 may perform better when slight imbalances of light transmission occur between positive and negative polarities, especially when the eye is tracking the motion of displayed images moving across the screen. Each of the Figures shows the polarities during half of the display addressing fields. The polarities are reversed for the other half, alternating every field, resulting in a net zero current (zero DC bias), as is well known in the art.

[0046] FIG. 20 depicts a system 2000 in which a display as constructed in accordance with the various embodiments disclosed herein is driven by a sub-pixel rendering technique 2004 which may be resident on a physical device 2002. An input image data stream 2008 may be input into the sub-pixel rendering technique 2004 and converted in the manner herein disclosed. An output image data stream 2010 is sent to the display device 2006 in order to drive the various sub-pixels to form an image thereupon. As discussed in several references incorporated herein, the sub-pixel rendering (SPR) technique 2004 may be implemented in either hardware and/or software or a combination thereof. For example, SPR techniques 2004 could be resident as logic (either hardware or software) on the display itself or it could reside on a graphics controller chip or board.

[0047] While the invention has been described with reference to exemplary embodiments, it will be understood by those skilled in the art that various changes may be made and equivalents may be substituted for elements thereof without departing from the scope of the invention. In addition, many modifications may be made to adapt a particular situation or material to the teachings without departing from the essential scope thereof. For example, some of the embodiments above may be implemented in other display technologies such as Organic Light Emitting Diode (OLED), ElectroLuminescent (EL), Electrophoretic, Active Matrix Liquid Crystal Display (AMLCD), Passive Matrix Liquid Crystal display (AMLCD), Incandescent, solid state Light Emitting Diode (LED), Plasma Display Panel (PDP), and Iridescent. Therefore, it is intended that the invention not be limited to the particular embodiment disclosed as the best mode contemplated for carrying out this invention, but that the invention will include all embodiments falling within the scope of the appended claims.

What is claimed is:

1. A display comprising a plurality of a sub-pixel group; said sub-pixel group further comprising eight sub-pixels;

wherein each said sub-pixel is one of a red color sub-pixel, a green color sub-pixel and a blue color sub-pixel;

wherein said sub-pixel group further comprises four sub-pixels of said blue color, two sub-pixels of said red color and two sub-pixels of said green color;

wherein further said sub-pixels of said red color and said sub-pixels of said green color form substantially a checkerboard pattern.

2. The display as recited in claim 1 wherein said sub-pixels of said blue color comprises a smaller area than said sub-pixels of said red color and said green color.

3. The display as recited in claim 1 where said sub-pixel group further comprises substantially two rows and four columns of sub-pixels; and

wherein further a first set of two non-adjacent columns comprise four sub-pixels of said blue color and a second set of two non-adjacent columns comprise two sub-pixels of said red color and two sub-pixels of said green color.

4. The display as recited in claim 3 wherein said two non-adjacent columns comprising four sub-pixels of said blue color are offset vertically from said two nonadjacent columns comprise two sub-pixels of said red color and two sub-pixels of said green color.

5. The display as recited in claim 1 wherein said sub-pixels of said blue color are interspersed said substantially formed checkerboard pattern of sub-pixels of said red color and said green color.

6. The display as recited in claim 1 wherein said display is an active matrix liquid crystal display.

7. The display as recited in claim 6 wherein said display applies a dot inversion scheme for driving the sub-pixels in each sub-pixel group.

8. The display as recited in claim 7 wherein said dot inversion scheme is 1×1 dot inversion.

9. The display as recited in claim 7 wherein said dot inversion scheme is 2×1 dot inversion.

10. In a display, said display comprising a plurality of a sub-pixel group; said sub-pixel group further comprising eight sub-pixels; wherein each said sub-pixel is one of a blue color sub-pixel, a red color sub-pixel and a green color sub-pixel; wherein said sub-pixel group further comprises four sub-pixels of said blue color, two sub-pixels of said red color and two sub-pixels of said green color; wherein further said sub-pixels of said red color and said sub-pixels of said green color form substantially a checkerboard pattern;

a method of converting a source pixel data of a first format for rendering onto said display comprising:

determining implied sample areas for each data point of incoming three-color pixel data;

determining the resample area for each color sub-pixel in the display;

forming a set of coefficients for each the resample area, said coefficients comprising fractions whose denominators are a function of the resample area and the numerators are a function of an area of each the implied sample areas that may partially overlap said resample areas;

multiplying the incoming pixel data for each implied sample area by the coefficient resulting in a product; and

adding each the product to obtain luminance values for each resample area.

11. The method as recited in claim 10 wherein determining the resample area further comprises:

determining a phase relationship between the resample area for each color subpixel.

12. The methods as recited in claim 11 wherein determining a phase relationship further comprises:

positioning resample points for each said color resample areas such that the resample points for said red color and said green color substantially overlay the resample points for said blue color.

13. In a display, said display comprising a plurality of a sub-pixel group; said sub-pixel group further comprising eight sub-pixels; wherein each said sub-pixel is one of a blue color sub-pixel, a red color sub-pixel and a green color sub-pixel; wherein said sub-pixel group further comprises four sub-pixels of said blue color, two sub-pixels of said red color and two sub-pixels of said green color; wherein further said sub-pixels of said red color and said sub-pixels of said green color form substantially a checkerboard pattern;

a method of converting a source pixel data of a first format for rendering onto said display comprising:

- inputting a set of color image data;
- testing the input data for a plurality of conditions; and
- taking appropriate actions in response to the outcome of said testing of the input data.

14. The method as recited in claim 13 wherein said set of color image input data comprises a sample of a 1x3 matrix of input data.

15. The method as recited in claim 13 wherein said set of color image input data comprises a sample of a 1x2 matrix of input data.

16. The method as recited in claim 13 wherein testing the input data for a plurality of conditions further comprises:

testing for the detection of a high contrast feature in the input data.

17. The method as recited in claim 16 wherein said high contrast feature comprises one of a group, said group comprising an edge, a line, and a dot.

18. The method as recited in claim 13 wherein taking appropriate actions in response to the outcome of said testing of the input data further comprises:

substituting a new color data value for the current color data value.

19. The method as recited in claim 13 wherein taking appropriate actions in response to the outcome of said testing of the input data further comprises:

applying gamma correction to the current color data value.

20. The method as recited in claim 13 wherein taking appropriate actions in response to the outcome of said testing of the input data further comprises:

apply new sub-pixel rendering filter coefficients to the input data.

21. A system comprising:

a display, said display comprising a plurality of a sub-pixel group; said sub-pixel group further comprising eight sub-pixels; wherein each said sub-pixel is one of

a blue color sub-pixel, a red color sub-pixel and a green color sub-pixel; wherein said sub-pixel group further comprises four sub-pixels of said blue color, two sub-pixels of said red color and two sub-pixels of said green color; wherein further said sub-pixels of said red color and said sub-pixels of said green color form substantially a checkerboard pattern; and

means for subpixel rendering input image data.

22. The system as recited in claim 21 wherein said means for subpixel rendering input data further comprises:

- means for inputting a set of color image data;
- means for testing the input data for a plurality of conditions; and
- means for taking appropriate actions in response to the outcome of said testing of the input data.

23. The system as recited in claim 22 wherein said set of color image input data comprises a sample of a 1x3 matrix of input data.

24. The system as recited in claim 22 wherein said set of color image input data comprises a sample of a 1x2 matrix of input data.

25. The system as recited in claim 22 wherein said means for testing the input data for a plurality of conditions further comprises:

means for testing for the detection of a high contrast feature in the input data.

26. The system as recited in claim 25 wherein said high contrast feature comprises one of a group, said group comprising an edge, a line, and a dot.

27. The system as recited in claim 22 wherein means for taking appropriate actions in response to the outcome of said testing of the input data further comprises:

means for substituting a new color data value for the current color data value.

28. The system as recited in claim 22 wherein means for taking appropriate actions in response to the outcome of said testing of the input data further comprises:

means for applying gamma correction to the current color data value.

29. The system as recited in claim 22 wherein means for taking appropriate actions in response to the outcome of said testing of the input data further comprises:

means for applying new sub-pixel rendering filter coefficients to the input data.

30. The system as recited in claim 21 wherein said means for subpixel rendering input data further comprises:

means for determining implied sample areas for each data point of incoming three-color pixel data;

means for determining the resample area for each color sub-pixel in the display;

means for forming a set of coefficients for each the resample area, said coefficients comprising fractions whose denominators are a function of the resample area and the numerators are a function of an area of each the implied sample areas that may partially overlap said resample areas;

means for multiplying the incoming pixel data for each implied sample area by the coefficient resulting in a product; and

means for adding each the product to obtain luminance values for each resample area.

\* \* \* \* \*