



US010832616B2

(12) **United States Patent**
Lee

(10) **Patent No.:** **US 10,832,616 B2**

(45) **Date of Patent:** **Nov. 10, 2020**

(54) **PIXEL ARRANGEMENT STRUCTURE FOR ORGANIC LIGHT EMITTING DIODE DISPLAY**

(58) **Field of Classification Search**
CPC G09G 3/3208; H01L 27/3216; H01L 27/3218

(71) Applicant: **SAMSUNG DISPLAY CO., LTD.**,
Yongin (KR)

(Continued)

(72) Inventor: **Sang-Shin Lee**, Yongin (KR)

(56) **References Cited**

(73) Assignee: **Samsung Display Co., Ltd.**, Yongin-si (KR)

U.S. PATENT DOCUMENTS

(*) Notice: Subject to any disclaimer, the term of this patent is extended or adjusted under 35 U.S.C. 154(b) by 616 days.

4,642,619 A 2/1987 Togashi
6,366,025 B1 4/2002 Yamada
(Continued)

(21) Appl. No.: **13/872,018**

FOREIGN PATENT DOCUMENTS

(22) Filed: **Apr. 26, 2013**

CN 101009304 A 8/2007
CN 101449382 A 6/2009
(Continued)

(65) **Prior Publication Data**

US 2014/0071030 A1 Mar. 13, 2014

OTHER PUBLICATIONS

Related U.S. Application Data

Extended European Search Report dated Dec. 20, 2013, for corresponding European Patent Application No. 13178648.5 (9 pages).
(Continued)

(63) Continuation-in-part of application No. 13/614,197, filed on Sep. 13, 2012, now Pat. No. 9,818,803.

Primary Examiner — Kwang-Su Yang

(74) *Attorney, Agent, or Firm* — Lewis Roca Rothgerber Christie LLP

(30) **Foreign Application Priority Data**

Mar. 6, 2012 (KR) 10-2012-0022967
Apr. 23, 2013 (KR) 10-2013-0044993

(57) **ABSTRACT**

A pixel arrangement structure of an organic light emitting diode (OLED) display is provided. The pixel arrangement structure includes: a first pixel having a center coinciding with a center of a virtual square; a second pixel separated from the first pixel and having a center at a first vertex of the virtual square; and a third pixel separated from the first pixel and the second pixel, and having a center at a second vertex neighboring the first vertex of the virtual square. The first pixel, the second pixel, and the third pixel have polygonal shapes.

(51) **Int. Cl.**

G09G 3/32 (2016.01)
H01L 27/32 (2006.01)
G09G 3/3208 (2016.01)

(52) **U.S. Cl.**

CPC **G09G 3/3208** (2013.01); **H01L 27/3216** (2013.01); **H01L 27/3218** (2013.01)

13 Claims, 6 Drawing Sheets

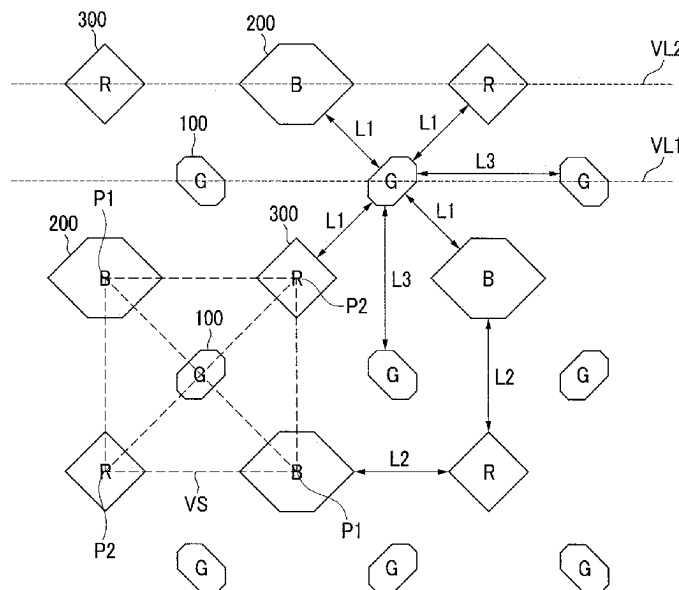

(58) **Field of Classification Search**
 USPC 345/82
 See application file for complete search history.

(56) **References Cited**

U.S. PATENT DOCUMENTS

6,867,549 B2* 3/2005 Cok et al. 315/169.3
 6,882,364 B1* 4/2005 Inuiya H04N 9/045
 348/237
 7,110,031 B2 9/2006 Kondo et al.
 7,274,383 B1* 9/2007 Elliot et al. 345/694
 7,710,484 B2 5/2010 Oda
 7,982,786 B2 7/2011 Nishida et al.
 8,026,669 B2 9/2011 Kawasaki et al.
 8,026,869 B2 9/2011 Takagi et al.
 8,330,352 B2 12/2012 Sung et al.
 8,350,468 B2 1/2013 Ko et al.
 8,354,789 B2 1/2013 Kim et al.
 9,431,469 B2 8/2016 Park et al.
 9,837,476 B2 12/2017 Park et al.
 2002/0015110 A1 2/2002 Brown Elliott
 2002/0070909 A1 6/2002 Asano et al.
 2002/0113195 A1* 8/2002 Osada G06T 3/4007
 250/208.1
 2002/0140833 A1 10/2002 Hirai
 2003/0128179 A1* 7/2003 Credelle G02F 1/133514
 345/88
 2003/0128225 A1 7/2003 Credelle et al.
 2004/0108818 A1 6/2004 Cok et al.
 2004/0183764 A1* 9/2004 Kim G09G 3/2059
 345/88
 2004/0246426 A1 12/2004 Wang et al.
 2005/0001542 A1 1/2005 Kiguchi
 2005/0162079 A1 7/2005 Sakamoto
 2006/0152531 A1 7/2006 Lin et al.
 2006/0274090 A1* 12/2006 Koyama G09G 3/3258
 345/695
 2008/0001525 A1* 1/2008 Chao et al. 313/500
 2008/0001527 A1* 1/2008 Koo H01L 27/12
 313/500
 2008/0273793 A1* 11/2008 Oishi H04N 5/217
 382/167
 2008/0308819 A1* 12/2008 Louwsma H01L 27/322
 257/89
 2009/0302331 A1* 12/2009 Smith H01L 27/3218
 257/88
 2010/0033084 A1 2/2010 Ko et al.
 2010/0117528 A1 5/2010 Fukuda
 2010/0133994 A1 6/2010 Song et al.
 2010/0171440 A1* 7/2010 Satou C09K 11/0883
 315/294
 2011/0012820 A1* 1/2011 Kim et al. 345/82
 2011/0291549 A1 12/2011 Kim et al.
 2011/0291550 A1 12/2011 Kim et al.
 2012/0049726 A1 3/2012 Yoo et al.
 2012/0056531 A1* 3/2012 Park et al. 313/506
 2012/0086330 A1 4/2012 Umeda et al.
 2012/0287605 A1 11/2012 Chen et al.
 2012/0313844 A1 12/2012 Im et al.
 2012/0319564 A1 12/2012 Ghosh et al.
 2013/0002911 A1 1/2013 Miyashita et al.
 2013/0037827 A1 2/2013 Levermore et al.
 2013/0057521 A1 3/2013 Kim
 2013/0106891 A1 5/2013 Matsueda et al.
 2013/0127689 A1 5/2013 Gollier
 2015/0192834 A1 7/2015 Morinaga et al.

FOREIGN PATENT DOCUMENTS

CN 103311266 A 9/2013
 CN 203260586 U 10/2013
 CN 105206647 A 12/2015
 EP 2 637 209 A1 9/2013
 GB 2 437 110 A 10/2007
 JP 3-36239 5/1991

JP 10-39791 2/1998
 JP 2000-235891 8/2000
 JP 2003-203770 A 7/2003
 JP 2004-507773 3/2004
 JP 2004-179028 A 6/2004
 JP 2004-192813 7/2004
 JP 2005-5227 A 1/2005
 JP 2006-18195 A 1/2006
 JP 2006-309182 11/2006
 JP 2007-156126 A 6/2007
 JP 2008-015521 1/2008
 JP 2008-300367 A 12/2008
 JP 2009-230096 A 10/2009
 JP 2010-3880 A 1/2010
 JP 2010-153173 A 7/2010
 JP 2011-076760 4/2011
 JP 2011-198761 A 10/2011
 KR 10-2004-0096706 A 11/2004
 KR 10-0742370 B1 7/2007
 KR 10-0807524 B1 2/2008
 KR 10-2008-0111130 12/2008
 KR 10-2009-0017910 A 2/2009
 KR 10-2009-0049515 A 5/2009
 KR 10-2011-0023996 A 3/2011
 KR 10-2011-0106565 A 9/2011
 KR 10-2011-0129531 12/2011
 KR 10-2012-0022967 A 3/2012
 TW 1328207 8/2010
 WO WO 03/053068 A2 6/2003
 WO WO 2004/073356 A1 8/2004
 WO WO 2005/067352 A1 7/2005

OTHER PUBLICATIONS

U.S. Office action dated Mar. 12, 2015, for cross reference U.S. Appl. No. 13/614,197, (13 pages).
 Korean Patent Abstracts of Korean Publication No. 10-2003-0031207 A, published Apr. 21, 2003, which corresponds to KR 10-0807524 B1, 2 pages.
 Korean Patent Abstracts for Korean Publication 1020070055908 dated May 31, 2007, corresponding to Korean Patent 10-0742370 dated Jul. 24, 2007.
 SIPO Office action dated Mar. 11, 2015, corresponding to Chinese Patent application 201310035429.X, (7 pages).
 Taiwan Office action dated Mar. 30, 2015, corresponding to Taiwanese Patent application 102101000, (7 pages).
 EPO Search Report dated Jul. 9, 2014, for European Patent application 14155124.2, (8 pages).
 EPO Search Report dated Jul. 8, 2013, for corresponding European Patent application 13157562.3, (6 pages).
 U.S. Office action dated Nov. 7, 2014, for cross reference U.S. Appl. No. 13/614,197, (16 pages).
 U.S. Office action dated Aug. 29, 2014, for cross reference U.S. Appl. No. 14/059,356, (18 pages).
 U.S. Office action dated Jul. 15, 2015, for cross reference U.S. Appl. No. 13/614,197, (11 pages).
 U.S. Office action dated Dec. 2, 2015, for cross reference U.S. Appl. No. 13/614,197, (12 pages).
 U.S. Office action dated Apr. 7, 2016, for parent U.S. Appl. No. 13/614,197, (13 pages).
 KIPO Office action dated Jul. 11, 2016, with English translation, for corresponding Korean Patent application 10-2016-0047800, (11 pages).
 English Abstract of TW 2008-02221 A, also published as TW 1328207.
 U.S. Office Action dated Oct. 14, 2016 issued in cross-reference U.S. Appl. No. 13/614,197 (12 pages).
 U.S. Office Action dated Sep. 3, 2019, issued in U.S. Appl. No. 16/261,437 (11 pages).
 U.S. Office Action dated Oct. 25, 2019, issued in U.S. Appl. No. 16/505,536 (14 pages).
 Office action issued in U.S. Appl. No. 15/811,599 by the USPTO, dated Jul. 19, 2019, 19 pages.
 U.S. Office Action dated Jul. 11, 2018, issued in U.S. Appl. No. 15/811,599 (19 pages).

(56)

References Cited

OTHER PUBLICATIONS

U.S. Office Action dated Mar. 19, 2018, issued in U.S. Appl. No. 15/688,760 (13 pages).

EPO Communication Pursuant to Article 94(3) EPC, for Patent Application No. 13 178 648.5, dated Jan. 31, 2019, 8 pages.

U.S. Office Action dated Apr. 30, 2020, issued in U.S. Appl. No. 16/505,536 (14 pages).

* cited by examiner

FIG. 1

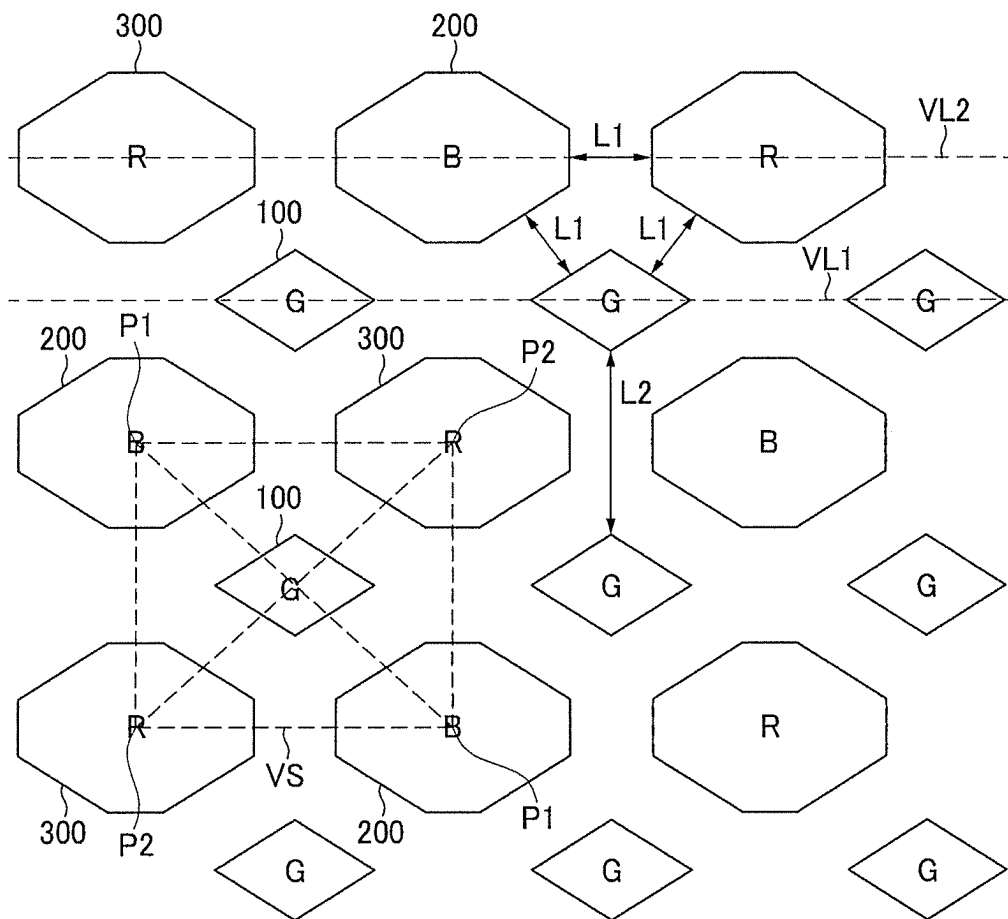

FIG. 2

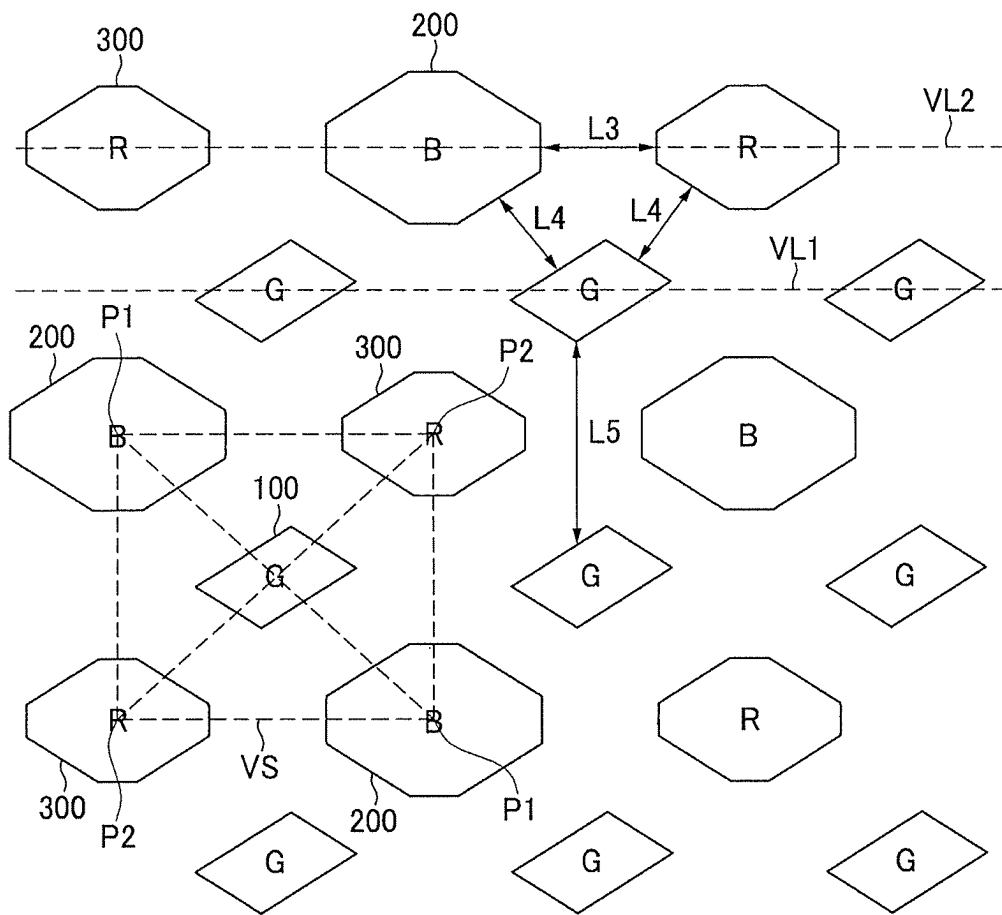

FIG.3

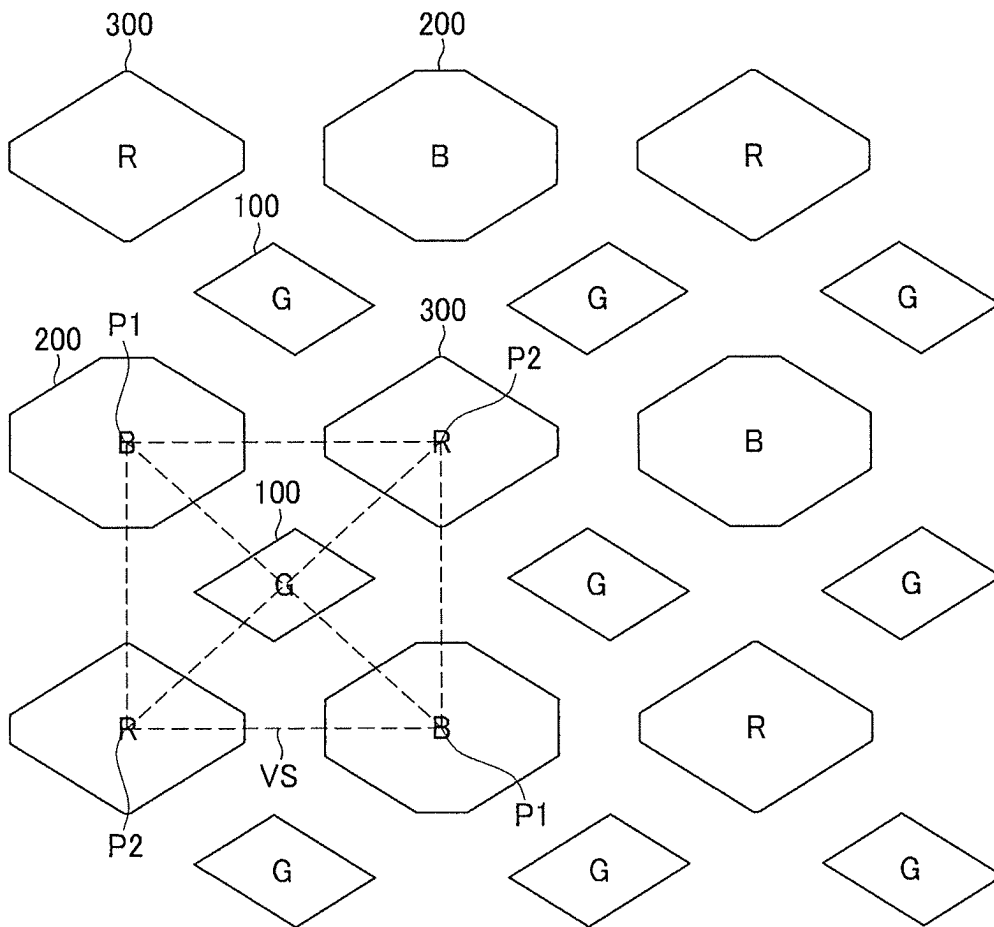
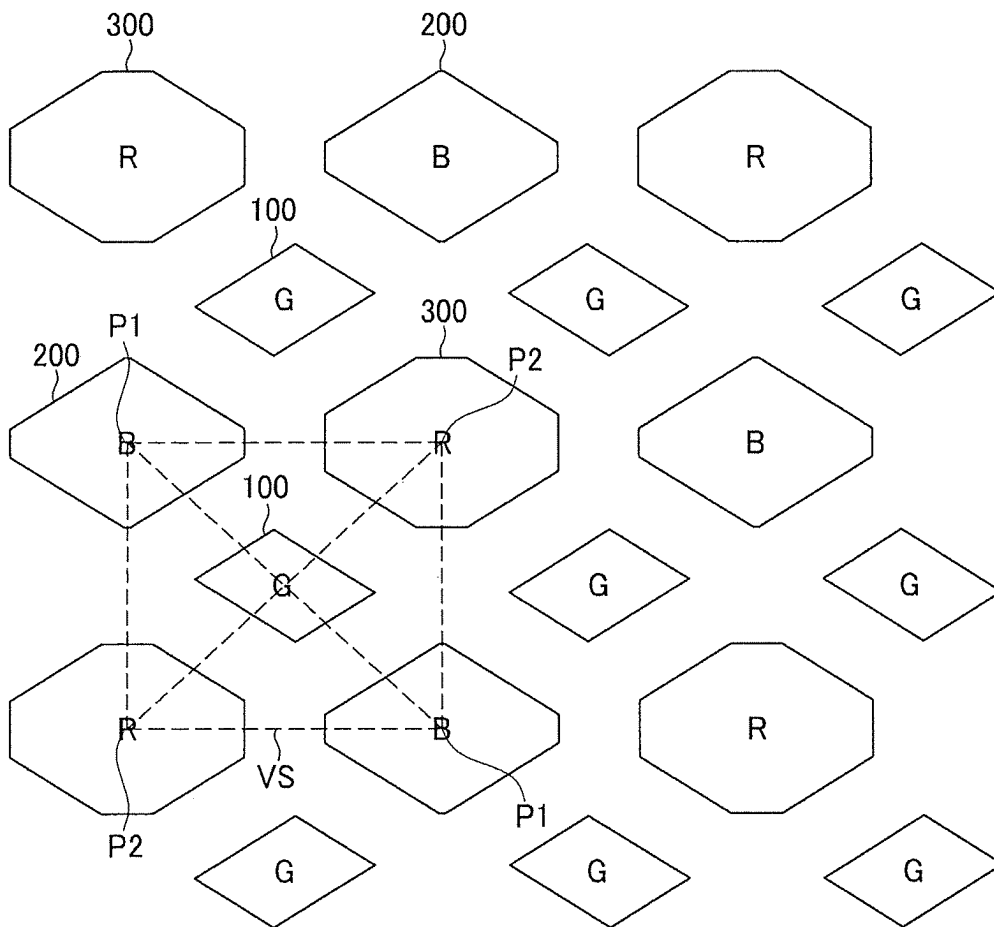

FIG.4



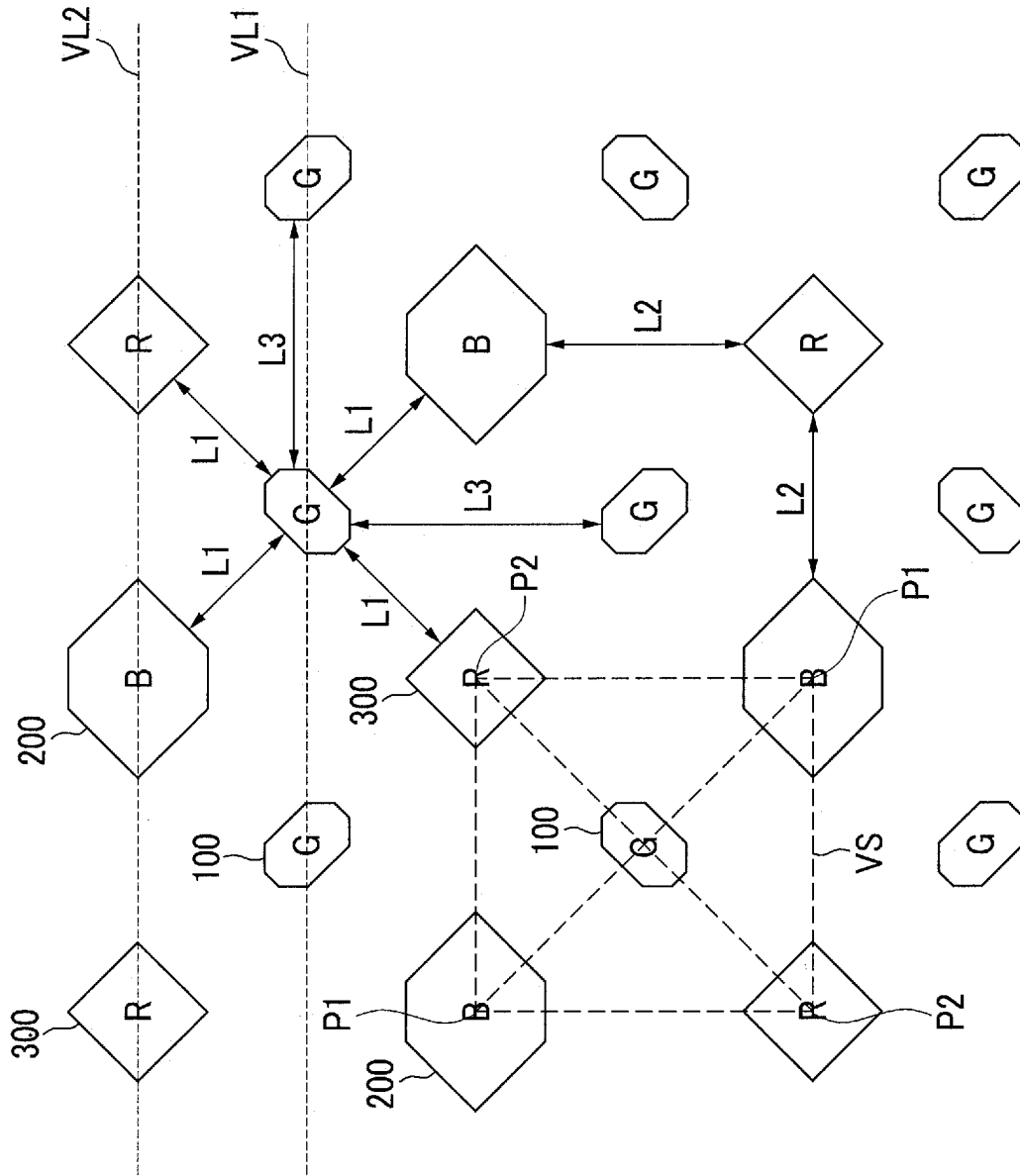

FIG. 6

1

**PIXEL ARRANGEMENT STRUCTURE FOR
ORGANIC LIGHT EMITTING DIODE
DISPLAY**

CROSS-REFERENCE TO RELATED
APPLICATION

This application is a continuation in part of U.S. application Ser. No. 13/614,197, filed Sep. 13, 2012, which claims priority to and the benefit of Korean Patent Application No. 10-2012-0022967, filed in the Korean Intellectual Property Office on Mar. 6, 2012. This application also claims priority to and the benefit of Korean Patent Application No. 10-2013-0044993, filed in the Korean Intellectual Property Office on Apr. 23, 2013. The entire contents of all of these are incorporated herein by reference.

BACKGROUND

1. Field

Aspects of embodiments of the present invention relate generally to a pixel arrangement structure for an organic light emitting diode (OLED) display.

2. Description of the Related Art

A display device is a device that displays an image. Recently, an OLED display has been drawing attention.

The OLED display has a self-luminous characteristic. Because the OLED display does not need a separate light source, unlike a liquid crystal display, it can have a relatively smaller thickness and weight than liquid crystal displays. In addition, the OLED display exhibits high-quality characteristics such as low power consumption, high luminance, high response speed, etc.

In general, the OLED display includes a plurality of pixels for emitting light of different colors. The plurality of pixels emit light to display an image.

Here, the pixel refers to a minimum unit for displaying the images. For instance, there may be a gate line, a data line, and a power line such as a driving power line to drive each pixel. In addition, there may be an insulation layer such as a pixel definition layer to define an area and a shape of each pixel. Further, each pixel may be positioned between its neighboring pixels.

An organic emission layer included in the pixel of an OLED display may be deposited and formed by using a mask such as a fine metal mask (FMM). When reducing a gap between the neighboring pixels to obtain a high aperture ratio of the pixels, deposition reliability may be deteriorated. On the other hand, when increasing the gap between the pixels to improve the deposition reliability, the aperture ratio of the pixels may be deteriorated.

The above information disclosed in this Background section is only for enhancement of understanding of the background of the invention and therefore it may contain information that does not form the prior art that is already known in this country to a person of ordinary skill in the art.

SUMMARY

Aspects of embodiments of the present invention relate generally to a pixel arrangement structure for an OLED display. More particularly, aspects of embodiments of the

2

present invention relate to a pixel arrangement structure of an OLED display that displays an image by emitting light through a plurality of pixels.

An exemplary embodiment of the present invention provides a pixel arrangement structure for an OLED display having an improved aperture ratio of each of the pixels while efficiently setting up gaps between the pixels.

According to an exemplary embodiment of the present invention, a pixel arrangement structure of an organic light emitting diode display is provided. The pixel arrangement structure includes: a first pixel having a center coinciding with a center of a virtual square; a second pixel separated from the first pixel and having a center at a first vertex of the virtual square; and a third pixel separated from the first pixel and the second pixel, and having a center at a second vertex neighboring the first vertex of the virtual square.

The second pixel may include a pair of second pixels. The second pixels may be separated from each other by the first pixel.

The third pixel may include a pair of third pixels. The third pixels may be separated from each other by the first pixel.

The second pixels and the third pixels may enclose the first pixel in the virtual square.

The first pixel, the second pixels, and the third pixels may have polygonal shapes. The second pixels and the third pixels may have a larger area than the first pixel.

The first pixel may have a quadrilateral shape. The second pixels and the third pixels may have hexagonal or octagonal shapes.

The second pixels and the third pixels may have octagonal shapes.

The second pixels and the third pixels may have a same area. A distance between the first pixel and the second pixels, a distance between the first pixel and the third pixels, and a distance between the second pixels and the third pixels may be a same first length.

The first pixel may include a plurality of first pixels. The plurality of first pixels may have a same quadrilateral shape. A distance between neighboring ones of the plurality of first pixels may be a second length that is longer than the first length.

The second pixels may have a larger area than the third pixels. A distance between the second pixels and the third pixels may be a first length. A distance between the first pixel and the second pixels, and a distance between the first pixel and the third pixels may be a same second length.

The first pixel may include a plurality of first pixels. The plurality of first pixels may have a same quadrilateral shape. A distance between neighboring ones of the plurality of first pixels may be a third length that is longer than the first length and the second length.

The first pixel may include a plurality of first pixels. Neighboring ones of the plurality of first pixels may have quadrilateral shapes that are symmetrical to each other. A distance between the neighboring ones of the plurality of first pixels may be a third length that is longer than the first length and the second length.

The first pixel may include a plurality of first pixels. Neighboring ones of the plurality of first pixels may have quadrilateral shapes that are symmetrical to each other.

The second pixels may have a larger area than the third pixels.

The third pixels may have a larger area than the second pixels.

The first pixel, the second pixel, and the third pixel may be configured to emit different color lights.

3

The first pixel, the second pixel, and the third pixel may be configured to emit green light, blue light, and red light, respectively.

According to an exemplary embodiment of the present invention, a pixel arrangement structure of an organic light emitting diode (OLED) display is provided. The pixel arrangement structure includes: a first pixel having a center coinciding with a center of a virtual square; a second pixel separated from the first pixel and having a center at a first vertex of the virtual square; and a third pixel separated from the first pixel and the second pixel, and having a center at a second vertex neighboring the first vertex of the virtual square. The first pixel, the second pixel, and the third pixel have polygonal shapes.

In one embodiment, the second pixel includes a pair of second pixels, and the second pixels are separated from each other by the first pixel.

In one embodiment, the third pixel includes a pair of third pixels, and the third pixels are separated from each other by the first pixel.

In one embodiment, the second pixel includes a pair of second pixels, the third pixel includes a pair of third pixels, and the second pixels and the third pixels enclose the first pixel in the virtual square.

In one embodiment, each of the second pixels and the third pixels is larger in area than the first pixel.

In one embodiment, the first pixel has an octagonal shape, and at least one of the second pixel or the third pixel has an octagonal shape.

In one embodiment, the first pixel has an octagonal shape, and one of the second pixel or the third pixel has a hexagonal shape and an other of the second pixel or the third pixel has a quadrilateral shape.

In one embodiment, the virtual square includes a pair of virtual squares sharing a common side, the first pixel includes a pair of first pixels having centers respectively coinciding with centers of the virtual squares, and the first pixels have octagonal shapes that are symmetrical to each other.

In one embodiment, each of the second pixels is larger in area than each of the third pixels.

In one embodiment, a distance between the first pixel and the second pixels as well as a distance between the first pixel and the third pixels is a same first length.

In one embodiment, the virtual square includes a pair of virtual squares sharing a common side, the first pixel includes a pair of first pixels having centers respectively coinciding with centers of the virtual squares, a distance between each of the second pixels and the third pixels is a same second length, and a distance between the first pixels is a third length that is longer than the first length and the second length.

In one embodiment, the first pixel, the second pixel, and the third pixel are configured to emit different color light.

In one embodiment, the first pixel is configured to emit green light, one of the second pixel or the third pixel is configured to emit blue light, and an other of the second pixel or the third pixel is configured to emit red light.

According to an exemplary embodiment of the present invention, the pixel arrangement structure of the OLED display improves the aperture ratio of the pixels while efficiently setting up the gaps between the pixels.

BRIEF DESCRIPTION OF THE DRAWINGS

FIG. 1 is a view of a pixel arrangement structure of an OLED display according to a first exemplary embodiment.

4

FIG. 2 is a view of a pixel arrangement structure of an OLED display according to a second exemplary embodiment.

FIG. 3 is a view of a pixel arrangement structure of an OLED display according to a third exemplary embodiment.

FIG. 4 is a view of a pixel arrangement structure of an OLED display according to a fourth exemplary embodiment.

FIG. 5 is a view of a pixel arrangement structure of an OLED display according to a fifth exemplary embodiment.

FIG. 6 is a view of a pixel arrangement structure of an OLED display according to a sixth exemplary embodiment.

DETAILED DESCRIPTION

Several exemplary embodiments according to the present invention are described hereinafter in detail with reference to the accompanying drawing to allow one of ordinary skill in the art to practice the invention without undue experimentation. The present invention can be embodied in several different forms, and is not limited to the exemplary embodiments that are described herein.

In order to clarify the description of embodiments of the present invention, parts that are not related to the invention may be omitted. In addition, the same elements or equivalents are referred to with the same reference numerals throughout the specification.

Further, since sizes and thicknesses of constituent members shown in the accompanying drawing may be arbitrarily given for better understanding and ease of description, the present invention is not limited to the illustrated sizes and thicknesses.

In addition, unless explicitly described to the contrary, the word “comprise” and variations such as “comprises” or “comprising” will be understood to imply the inclusion of stated elements but not the exclusion of any other elements.

Nevertheless, even though each of the pixels are drawn as stereotypical polygonal shapes in the drawings, the present invention is not limited to this shape. That is, the shapes of the pixels may be modified to avoid interference with the other components of the OLED (e.g., wirings) within the spirit and scope of the appended claims.

A pixel arrangement structure (or pixel arrangement) of an OLED display according to a first exemplary embodiment will be described with reference to FIG. 1. FIG. 1 is a view schematically showing a portion of pixels forming an OLED display.

As shown in FIG. 1, the pixel arrangement structure of the OLED display includes a plurality of first pixels **100**, a plurality of second pixels **200**, and a plurality of third pixels **300**. Here, the pixel refers to a minimum unit for displaying an image (for example, the minimum addressable unit of the display).

Further, among the first pixels **100**, the second pixels **200**, and the third pixels **300**, power lines for driving each of the pixels, such as a gate line, a data line, a driving power line, and the like, may be located. In addition, an insulation layer, such as a pixel defining layer, for defining each of the pixels may be disposed. Finally, an OLED including an anode, an organic emission layer, and a cathode to correspond to each of the first pixels **100**, the second pixels **200**, and the third pixels **300** may be disposed. These configurations are technologies known in the art and further description thereof is omitted for ease of description. A shape of each of the pixels may be defined by the power lines, the pixel defining layer, the anode, or the like, but is not limited thereto.

5

In the pixel arrangement of FIG. 1, each of the first pixels 100 has a smaller area than neighboring second pixels 200 and third pixels 300, and has a quadrilateral (i.e., four-sided) shape among polygon shapes. For example, in the pixel arrangement of FIG. 1, each of the first pixels 100 has the same quadrilateral shape (e.g., a square or rhombus). The first pixels 100 are spaced apart from each other and arranged in rows, such as along a first virtual straight line VL1. The first pixels 100 emit green light, and may include an organic emission layer for emitting green light.

The second pixels 200 are arranged diagonally with respect to the first pixels 100, such as at first vertices P1 along one diagonal of a virtual square VS having one of the first pixels 100 as a center point (or center) of the virtual square VS. In a similar fashion, the third pixels 300 are arranged diagonally with respect to the first pixels 100, such as at second vertices P2 along the other diagonal of the virtual square VS.

In the virtual square VS, each of the second pixels 200 is separated from the first pixel 100, and is centered at one of the first vertices P1 of the virtual square VS. Each of the second pixels 200 has a larger area than the neighboring first pixel 100 and has an octagonal (i.e., eight-sided) shape. In FIG. 1, the second pixels 200 each have the same octagonal shape. In addition, the second pixels 200 are arranged diagonally and separated from each other by the first pixels 100. The second pixels 200 emit blue light, and may include an organic emission layer for emitting blue light.

In a similar fashion, in the virtual square VS, each of the third pixels 300 is separated from the first pixel 100 and the second pixels 200, and is centered at one of the second vertices P2 neighboring the first vertices P1 of the virtual square VS. Each of the third pixels 300 has a larger area than the neighboring first pixel 100 and the same area as each of the second pixels 200. Further, the third pixels have an octagonal shape (e.g., similar to or the same as the second pixels 200). In FIG. 1, the third pixels 300 each have the same octagonal shape. In addition, the third pixels 300 are arranged diagonally and separated from each other by the first pixels 100. The third pixels 300 emit red light, and may include an organic emission layer for emitting red light.

The third pixels 300 and the second pixels 200 are spaced apart from each other and alternately arranged in rows, such as along a second virtual straight line VL2. In a similar fashion, the third pixels 300 and the second pixels 200 are spaced apart from each other and alternately arranged in columns. Accordingly, in the virtual square VS, two of the second pixels 200 having their corresponding centers positioned at the first vertices P1 and two of the third pixels 300 having their corresponding centers positioned at the second vertices P2 to enclose a corresponding one of the first pixels 100 (e.g., in the virtual square VS).

As described above, the center of each of the second pixels 200 is positioned at one of the first vertices P1 of the virtual square VS. In addition, the center of the corresponding first pixel 100 is the center of the virtual square VS. Further, the center of each of the third pixels 300 is positioned at one of the second vertices P2. Moreover, the second pixels 200 and the third pixels 300 each have the same area.

As a non-limiting example, the distance (e.g., a shortest distance) between one of the first pixels 100 and an adjacent one of the second pixels 200 is a first length L1, the distance between one of the first pixels 100 and an adjacent one of the third pixels 300 is the same first length L1, and the distance between one of the second pixels 200 and an adjacent one of the third pixels 300 is the same first length L1, as shown in

6

FIG. 1. In addition, the distance (e.g., a shortest distance) between the neighboring first pixels 100 is a second length L2 that is longer than the first length L1. It should be noted that L1, L2, L3, . . . may be used throughout to represent shortest distances between corresponding pixels.

Therefore, the gap of the first length L1 is formed between adjacent pairs of the first pixels 100 and the second pixels 200, between adjacent pairs of the first pixels 100 and the third pixels 300, and between adjacent pairs of the second pixels 200 and the third pixels 300. In addition, the gap of the second length L2 that is longer than the first length L1 is formed between the neighboring ones of the first pixels 100. This results in improved deposition reliability when using a fine metal mask to form the green, blue, and red organic emission layers respectively included in the first pixels 100, the second pixels 200, and the third pixels 300.

In addition, by enclosing each of the first pixels 100 by a pair of the second pixels 200 and a pair of the third pixels 300, the aperture ratio of the first pixels 100, the second pixels 200, and the third pixels 300 may be improved. Accordingly, a manufacturing time and manufacturing cost of the entire OLED display may be reduced and the display quality of the image of the OLED display may be improved.

As described above, in the pixel arrangement structure of the OLED display of FIG. 1, the first pixels 100, the second pixels 200, and the third pixels 300 have polygonal shapes (e.g., the first pixels have a quadrilateral shape and the second pixels 200 and the third pixels 300 have an octagonal shape). In addition, it is worth considering that the deposition process of the organic emission layer is one of the unique manufacturing characteristics of the OLED display. Accordingly, to improve the deposition reliability of the organic emission layer in the deposition process using the fine metal mask and to improve the aperture ratio of the first pixels 100, the second pixels 200, and the third pixels 300, the center of each of the first pixels 100 is positioned at the center of a virtual square VS formed by a first pair of diagonal vertices P1 and a second pair of diagonal vertices P2. In the virtual square VS, the centers of a pair of the second pixels 200 are positioned at the first vertices P1, and the centers of a pair of the third pixels 300 are positioned at the second vertices P2.

In addition, in the pixel arrangement structure of the OLED display of FIG. 1, the first pixels 100, the second pixels 200, and the third pixels 300 respectively emit green, blue, and red light. However, in pixel arrangement structures of other OLED displays, the first pixels 100, the second pixels 200, and the third pixels 300 may emit light of different colors. For example, at least one of the second pixels 200 or the third pixels may emit white light.

Next, a pixel arrangement structure of an OLED display according to a second exemplary embodiment will be described with reference to FIG. 2. Parts that are different from the exemplary embodiment of FIG. 1 will be described, while the description of parts that are equivalent to the first exemplary embodiment may be omitted. For better comprehension and ease of description, constituent elements of the second exemplary embodiment that are the same as or similar to those of the first embodiment of FIG. 1 will have the same reference numerals.

As shown in FIG. 2, the pixel arrangement structure of the OLED display includes a plurality of first pixels 100, a plurality of second pixels 200, and a plurality of third pixels 300. The plurality of first pixels 100 have the same quadrilateral shape (e.g., a parallelogram). In addition, the second pixels 200 have a larger area than the third pixels 300. The

second pixels 200 and the third pixels 300 may have polygonal shapes, such as octagonal or hexagonal (i.e., six-sided).

In a similar fashion to that of FIG. 1, the centers of a pair of the second pixels 200 are positioned at first vertices P1 along one diagonal of a virtual square VS having a center coinciding with a center of one of the first pixels 100. In addition, the centers of a pair of the third pixels 300 are positioned at second vertices P2 along another diagonal of the virtual square VS. However, in FIG. 2, the second pixels 200 have a larger area than the third pixels 300.

As a non-limiting example, the distance between adjacent ones of the second pixels 200 and the third pixels 300 is a third length L3, while the distance between each of the first pixels 100 and adjacent ones of the second pixels 200 or the third pixels 300 have a same fourth length L4. In addition, the distance between neighboring ones of the first pixels 100 is a fifth length L5 that is longer than the third length L3 and the fourth length L4.

Accordingly, the gap of the fourth length L4 is formed between adjacent pairs of the first pixels 100 and the second pixels 200, and between adjacent pairs of the first pixels 100 and the third pixels 300. In addition, the gap of the third length L3 is formed between adjacent pairs of the second pixels 200 and the third pixels 300. Further, the gap of the fifth length L5 that is longer than the third length L3 and the fourth length L4 is formed between the neighboring ones of the first pixels 100. This results in improved deposition reliability in the deposition process using the fine metal mask to form the green, blue, and red organic emission layers respectively included in the first pixels 100, the second pixels 200, and the third pixels 300.

In addition, by enclosing each of the first pixels 100 by a pair of the second pixels 200 and a pair of the third pixels 300, the aperture ratio of the first pixels 100, the second pixels 200, and the third pixels 300 may be improved. Accordingly, the manufacturing time and the manufacturing cost of the OLED display may be reduced and the display quality of the image of the OLED display may be improved.

Further, in the pixel arrangement structure of the OLED display of FIG. 2, the second pixels 200 that emit blue have the shortest life span among the first pixels 100, the second pixels 200, and the third pixels 300. Accordingly, the second pixels 200 have a larger area than the third pixels 300, thereby suppressing the deterioration of the life span of the OLED display. That is, the pixel arrangement structure of the OLED display of FIG. 2 provides improved life span.

Next, a pixel arrangement structure of an OLED display according to a third exemplary embodiment will be described with reference to FIG. 3. Parts that are different from the above exemplary embodiments will be described, while the description of parts that are equivalent to the above exemplary embodiments may be omitted. For better comprehension and ease of description, constituent elements of the third exemplary embodiment that are the same as or similar to the above exemplary embodiments will have the same reference numerals.

As shown in FIG. 3, the pixel arrangement structure of the OLED display includes a plurality of first pixels 100, a plurality of second pixels 200, and a plurality of third pixels 300. Among the plurality of first pixels 100, the neighboring first pixels 100 have a quadrilateral shape (e.g., parallelogram) and are symmetrical to each other. In addition, the second pixels 200 have a larger area than the third pixels 300. The second pixels 200 and the third pixels may have polygonal shapes (e.g., hexagonal or octagonal).

In a similar fashion to that of FIGS. 1-2, the centers of a pair of the second pixels 200 are positioned at first vertices P1 along one diagonal of a virtual square VS having a center coinciding with a center of one of the first pixels 100. In addition, the centers of a pair of the third pixels 300 are positioned at second vertices P2 along another diagonal of the virtual square VS. However, in FIG. 3, the neighboring first pixels 100 have a quadrilateral shape and are symmetrical to each other, while the second pixels 200 have a larger area than the third pixels 300. This results in improved deposition reliability in the deposition process using the fine metal mask to form the green, blue, and red organic emission layers respectively included in the first pixels 100, the second pixels 200, and the third pixels 300.

In addition, by placing each of the first pixels 100 between a pair of the second pixels 200 and between a pair of the third pixels 300, the aperture ratio of the first pixels 100, the second pixels 200, and the third pixels 300 may be improved. Accordingly, the manufacturing time and the manufacturing cost of the OLED display may be reduced and the display quality of the image of the OLED display may be improved.

Further, in the pixel arrangement structure of the OLED display of FIG. 3, the second pixels 200 that emit blue have the shortest life span among the first pixels 100, the second pixels 200, and the third pixels 300. Accordingly, the second pixels 200 have a larger area than the third pixels 300, thereby suppressing the deterioration of the life span of the OLED display. That is, the pixel arrangement structure of the OLED display provides improved life span.

Next, a pixel arrangement structure of an OLED display according to a fourth exemplary embodiment will be described with reference to FIG. 4. Parts that are different from the above exemplary embodiments will be described, while the description of parts that are equivalent to the above exemplary embodiments may be omitted. For better comprehension and ease of description, constituent elements of the fourth exemplary embodiment that are the same as or similar to the above exemplary embodiments will have the same reference numerals.

As shown in FIG. 4, the pixel arrangement structure of the OLED display includes a plurality of first pixels 100, a plurality of second pixels 200, and a plurality of third pixels 300. Among the plurality of first pixels 100, the neighboring first pixels 100 have a quadrilateral shape (e.g., parallelogram) and are symmetrical to each other. In addition, the third pixels 300 have a larger area than the second pixels 200. The second pixels 200 and the third pixels may have polygonal shapes (e.g., hexagonal or octagonal).

In a similar fashion to that of FIGS. 1-3, the centers of a pair of the second pixels 200 are positioned at the first vertices P1 along one diagonal of a virtual square VS having a center coinciding with a center of one of the first pixels 100. In addition, the centers of a pair of the third pixels 300 are positioned at second vertices P2 along another diagonal of the virtual square VS. However, in FIG. 4, the neighboring first pixels 100 have a quadrilateral shape and are symmetrical to each other, while the third pixels 300 have a larger area than the second pixels 200. This results in improved deposition reliability in the deposition process using the fine metal mask to form the green, blue, and red organic emission layers respectively included in the first pixels 100, the second pixels 200, and the third pixels 300.

In addition, by enclosing each of the first pixels 100 by a pair of the second pixels 200 and a pair of the third pixels 300, the aperture ratio of the first pixels 100, the second pixels 200, and the third pixels 300 may be improved.

Accordingly, the manufacturing time and the manufacturing cost of the OLED display may be reduced and the display quality of the image of the OLED display may be improved.

Next, a pixel arrangement structure of an OLED display according to a fifth exemplary embodiment will be described with reference to FIG. 5. Parts that are different from the above exemplary embodiments will be described, while the description of parts that are equivalent to the above exemplary embodiments may be omitted. For better comprehension and ease of description, constituent elements of the fifth exemplary embodiment that are the same as or similar to the above exemplary embodiments will have the same reference numerals.

As shown in FIG. 5, the pixel arrangement structure of the OLED display includes a plurality of first pixels 100, a plurality of second pixels 200, and a plurality of third pixels 300. Among the plurality of first pixels 100, the neighboring first pixels 100 have a octagonal shape and are symmetrical to each other. In addition, the second pixels 200 have a larger area than the third pixels 300. The second pixels 200 and the third pixels 300 may have quadrilateral shapes (e.g., rhombus).

In a similar fashion to that of FIGS. 1-3, the centers of a pair of the second pixels 200 are positioned at the first vertices P1 along one diagonal of a virtual square VS having a center coinciding with a center of one of the first pixels 100. In addition, the centers of a pair of the third pixels 300 are positioned at second vertices P2 along another diagonal of the virtual square VS. However, in FIG. 5, the neighboring first pixels 100 have a octagonal shape and are symmetrical to each other, while the second pixels 200 have a larger area than the third pixels 300. This results in improved deposition reliability in the deposition process using the fine metal mask to form the green, blue, and red organic emission layers respectively included in the first pixels 100, the second pixels 200, and the third pixels 300.

In addition, by enclosing each of the first pixels 100 by a pair of the second pixels 200 and a pair of the third pixels 300, the aperture ratio of the first pixels 100, the second pixels 200, and the third pixels 300 may be improved. Accordingly, the manufacturing time and the manufacturing cost of the OLED display may be reduced and the display quality of the image of the OLED display may be improved.

Hereinafter, a pixel arrangement structure (or pixel arrangement) of an OLED display according to an exemplary embodiment will be described with reference to FIG. 6. FIG. 6 is a view schematically showing a portion of pixels forming an OLED display.

FIG. 6 shows a pixel arrangement structure of an OLED display according to an exemplary embodiment of the present invention.

As shown in FIG. 6, the pixel arrangement structure of the OLED display includes a plurality of first pixels 100, a plurality of second pixels 200, and a plurality of third pixels 300.

According to one embodiment, the pixel refers to a minimum unit for displaying an image (for example, the minimum addressable unit of the display).

In one embodiment, among the first pixels 100, the second pixels 200, and the third pixels 300, power lines for driving each of the pixels, such as a gate line, a data line, a driving power line, and the like, are located. In addition, in one embodiment, an insulation layer, such as a pixel defining layer, for defining each of the pixels is disposed. Further, in one embodiment, an OLED including an anode, an organic emission layer, and a cathode to correspond to each of the first pixels 100, the second pixels 200, and the third pixels

300 is disposed. These configurations are technologies known in the art and further description thereof is omitted for ease of description. In one embodiment, the shape of each of the pixels is defined by the power lines, the pixel defining layer, the anode, or the like.

In the pixel arrangement of FIG. 6, each of the first pixels 100 has a smaller area (e.g., is smaller in area) than neighboring second pixels 200 and third pixels 300, and has a polygon shape. In FIG. 6, the first pixels 100 have an octagonal shape among the polygon shapes. In other embodiments, the first pixels 100 have one or more of various polygon shapes such as a triangle, a rectangle, a pentagon, a hexagon, a heptagon, and the like. For example, the first pixels 100 that neighbor each other among the plurality of first pixels 100 have hexagonal shapes that are symmetrical to each other. In one embodiment, each of the plurality of first pixels 100 has the same hexagonal shape.

In one embodiment, the first pixels 100 are spaced apart from each other and arranged in rows, such as along a first virtual straight line VL1. In one embodiment, the first pixels 100 emit green light, and include an organic emission layer for emitting green light. In other embodiments, the first pixels 100 include an organic emission layer that emits light of one or more of various colors such as blue, red, or white color for emitting blue light, red light, or white light.

In FIG. 6, the second pixels 200 are arranged diagonally with respect to the first pixels 100, namely at first vertices P1 along one diagonal of a virtual square VS having one of the first pixels 100 as a center point (or center) of the virtual square VS. In a similar fashion, in FIG. 6, the third pixels 300 are arranged diagonally with respect to the first pixels 100, namely at second vertices P2 along the other diagonal of the virtual square VS.

In the virtual square VS of FIG. 6, each of the second pixels 200 is separated from the first pixel 100, and is centered at one of the first vertices P1 of the virtual square VS. Each of the second pixels 200 has a larger area than the neighboring first pixel 100 and the neighboring third pixels 300, and has a hexagonal shape. In other embodiments, the second pixels 200 have one or more of various polygonal shapes such as a triangle, a rectangle, a pentagon, a hexagon, a heptagon, and the like.

In FIG. 6, the second pixels 200 each have the same hexagonal shape. In addition, the second pixels 200 are arranged diagonally and separated from each other by the first pixels 100. In one embodiment, the second pixels 200 emit blue light, and include an organic emission layer for emitting blue light. In other embodiments, the second pixels 200 include an organic emission layer that emits light of one or more of various colors such as red, green, or white for emitting red light, green light, or white light.

In a similar fashion, in the virtual square VS of FIG. 6, each of the third pixels 300 is separated from the first pixel 100 and the second pixels 200, and is centered at one of the second vertices P2 neighboring the first vertices P1 of the virtual square VS. Each of the third pixels 300 has a larger area than the neighboring first pixel 100 and a smaller area than the neighboring second pixels 200. The third pixels 300 has a quadrilateral shape among polygon shapes. In other embodiments, the third pixels 300 have one or more of various polygonal shapes such as a triangle, a rectangle, a pentagon, a hexagon, a heptagon, and the like.

In FIG. 6, the third pixels 300 each have the same quadrilateral shape. In addition, the third pixels 300 are arranged diagonally and separated from each other by the first pixels 100. In one embodiment, the third pixels 300 emit red light, and include an organic emission layer for emitting

11

red light. In other embodiments, the third pixels **300** include an organic emission layer that emits light of one or more of various colors such as blue, green, or white for emitting blue light, green light, or white light.

In FIG. 6, each of the second pixels **200** and the third pixels **300** has a hexagonal shape and a quadrilateral shape, respectively. In another embodiment, each of the second pixels **200** and the third pixels **300** respectively has a quadrilateral shape and a hexagonal shape. That is, in this other embodiment, one of the second pixels **200** or the third pixels **300** has a hexagonal shape and the other has a quadrilateral shape.

In one embodiment, the first pixels **100**, the second pixels **200**, and the third pixels **300** respectively emit green light, blue light, and red light. In other embodiments, the first pixels **100**, the second pixels **200**, and the third pixels **300** emit light of the same color. In still other embodiments, the first pixels **100**, the second pixels **200**, and the third pixels **300** emit light of different colors. In some embodiments, the first pixels **100** emit green light, and one of the second pixels **200** or the third pixels **300** emit blue light while the other emit red light.

In FIG. 6, third pixels **300** and the second pixels **200** are spaced apart from each other and alternately arranged in rows, such as along a second virtual straight line VL2. In a similar fashion, in FIG. 6, the third pixels **300** and the second pixels **200** are spaced apart from each other and alternately arranged in columns. Accordingly, in FIG. 6, in the virtual square VS, two of the second pixels **200** have their corresponding centers positioned at the first vertices P1 and two of the third pixels **300** have their corresponding centers positioned at the second vertices P2 to enclose a corresponding one of the first pixels **100** in the virtual square VS.

As described and illustrated in FIG. 6, the center of each of the second pixels **200** is positioned at one of the first vertices P1 of the virtual square VS. In addition, the center of the corresponding first pixel **100** is the center of the virtual square VS. Further, the center of each of the third pixels **300** is positioned at one of the second vertices P2. Therefore, the plurality of second pixels **200** of which the centers are positioned at the first vertices P1 and the plurality of third pixels **300** of which the centers are positioned at the second vertices P2 respectively enclose one of the first pixels **100** in the virtual square VS.

Further, and as illustrated in FIG. 6, the first pixels **100**, the second pixels **200**, and the third pixels **300** have polygon shapes. In FIG. 6, the distance between one of the first pixels **100** and an adjacent one of the second pixels **200** as well as a distance between one of the first pixels **100** and an adjacent one of the third pixels **300** is the same first length L1. In addition, a distance between one of the second pixels **200** and an adjacent one of the third pixels **300** is a second length L2 that is different from the first length L1. Further, in FIG. 6, a distance between neighboring first pixels **100** is a third length L3 that is longer than the first length L1 and the second length L2.

For example, in some embodiments, the first length L1 is between 15 μm (micrometers) and 35 μm , the second length L2 is between 20 μm and 45 μm , and the third length L3 is between 25 μm and 65 μm .

Therefore, gaps of the first length L1 are formed between adjacent pairs of the first pixels **100** and the second pixels **200**, and between adjacent pairs of the first pixels **100** and the third pixels **300**. In addition, the gaps of the third length L3 that is longer than the first length L1 are formed between the neighboring ones of the first pixels **100**. In one embodiment, this results in improved deposition reliability in the

12

deposition process using the fine metal mask to form the green, blue, and red organic emission layers respectively included in the first pixels **100**, the second pixels **200**, and the third pixels **300**.

In addition, in one embodiment, the plurality of second pixels **200** and the plurality of third pixels **300** are arranged to enclose the first pixels **100** in the virtual squares VS so that an aperture ratio of each of the first pixels **100**, the second pixels **200**, and the third pixels **300** can be improved. Accordingly, in one embodiment, the manufacturing time and the manufacturing cost of the OLED display is reduced and the display quality of the image of the OLED display is improved.

Further, in the pixel arrangement structure of the OLED display of FIG. 6 according to an exemplary embodiment of the present invention, the second pixels **200** that emit blue light have the shortest life span among the first pixels **100**, the second pixels **200**, and the third pixels **300**. Accordingly, the second pixels **200** have a larger area than the first pixels **100** and the third pixels **300**, thereby suppressing the deterioration of the life span of the OLED display. That is, in one embodiment, the pixel arrangement structure of the OLED display of FIG. 6 provides improved life span.

As described above, in the pixel arrangement structure of the OLED display of FIG. 6 according to an exemplary embodiment of the present invention, the first pixels **100**, the second pixels **200**, and the third pixels **300** have simple polygonal shapes such as an octagon, a hexagon, and a quadrangle. In consideration of the deposition process of the organic emission layer, which in one embodiment is a unique manufacturing feature of the OLED display, a center of one of the first pixels **100** is positioned at the center of the virtual square VS, a center of one of the second pixels **200** is positioned at the first vertex P1, and a center of one of the third pixels **300** is positioned at the second vertex P2 to both improve deposition reliability of the organic emission layer in the deposition process using the fine metal mask and improve an aperture of each of the first, second, and third pixels **100**, **200**, and **300**.

That is, according to an exemplary embodiment of the present invention as illustrated in FIG. 6, the pixel arrangement structure of the OLED display includes a plurality of first pixels **100** having an octagonal shape, a plurality of second pixels **200** having a hexagonal shape, and a plurality of third pixels **300** having a quadrilateral shape. In one or more embodiments, the shapes and arrangement of the first pixels **100**, the second pixels **200**, and the third pixels **300** improve the deposition reliability of the organic emission layer while also improving the aperture ratio of each of the first pixels **100**, the second pixels **200**, and the third pixels **300**.

While this invention has been described in connection with what is presently considered to be practical exemplary embodiments, it is to be understood that the invention is not limited to the disclosed embodiments, but, on the contrary, is intended to cover various modifications and equivalent arrangements included within the spirit and scope of the appended claims, and equivalents thereof.

DESCRIPTION OF SOME SYMBOLS

first pixel **100**, second pixels **200**, third pixels **300**

What is claimed is:

1. A pixel arrangement structure of an organic light emitting diode (OLED) display, comprising:

13

a plurality of individually addressable pixels for displaying images, the individually addressable pixels being minimum addressable units of the OLED display and comprising:

a first pixel having a center coinciding with a center of a virtual square;

another first pixel having a center coinciding with a center of another virtual square, the virtual squares sharing a common side having endpoints at a common first vertex and a common second vertex of the virtual squares, with neighboring vertices in each of the virtual squares corresponding to pixels configured to emit different color light;

a second pixel separated from the first pixels and having a center at the first vertex;

an other first pixel on a line defined by the center of the virtual square and the first vertex, the first pixel, the second pixel, and the other first pixel being consecutive pixels on the line; and

a third pixel separated from the first pixels and the second pixel, and having a center at the second vertex,

wherein a shortest distance between the first pixel and the second pixel as well as a shortest distance between the first pixel and the third pixel is a same first length,

wherein a shortest distance between the first pixels is a second length that is longer than the first length and a shortest distance between each of the second pixels and the third pixels,

wherein the second pixel and the third pixel have polygonal shapes, and

wherein the second pixel has a larger area than that of the third pixel.

2. The pixel arrangement structure of claim 1, wherein the second pixel comprises a pair of second pixels, and the second pixels are separated from each other by the first pixel.

3. The pixel arrangement structure of claim 1, wherein the third pixel comprises a pair of third pixels, and the third pixels are separated from each other by the first pixel.

4. The pixel arrangement structure of claim 1, wherein the second pixel comprises a pair of second pixels, the third pixel comprises a pair of third pixels, and the second pixels and the third pixels enclose the first pixel in the virtual square.

5. The pixel arrangement structure of claim 4, wherein each of the second pixels and the third pixels is larger in area than the first pixel.

6. The pixel arrangement structure of claim 5, wherein one of the second pixel and the third pixel has a hexagonal shape and another of the second pixel and the third pixel has a quadrilateral shape.

14

7. The pixel arrangement structure of claim 6, wherein the first pixels are symmetrical to each other.

8. The pixel arrangement structure of claim 6, wherein each of the second pixels is larger in area than each of the third pixels.

9. The pixel arrangement structure of claim 5, wherein at least one of the second pixel and the third pixel has a hexagonal shape.

10. The pixel arrangement structure of claim 1, wherein the first pixel, the second pixel, and the third pixel are configured to emit different color light.

11. The pixel arrangement structure of claim 1, wherein the first pixel is configured to emit green light, one of the second pixel and the third pixel is configured to emit blue light, and another of the second pixel and the third pixel is configured to emit red light.

12. The pixel arrangement structure of claim 1, wherein the second pixel has a different polygonal shape from the third pixel.

13. A pixel arrangement structure of an organic light emitting diode (OLED) display, comprising:

a plurality of individually addressable pixels for displaying images, the individually addressable pixels being minimum addressable units of the OLED display and comprising:

a first pixel having a center coinciding with a center of a virtual square;

another first pixel having a center coinciding with a center of another virtual square, the virtual squares sharing a common side having endpoints at a common first vertex and a common second vertex of the virtual squares, with neighboring vertices in each of the virtual squares corresponding to pixels configured to emit different color light;

a second pixel separated from the first pixels and having a center at the first vertex; and

a third pixel separated from the first pixels and the second pixel, and having a center at the second vertex,

the first pixel, the second pixel, and the third pixel have polygonal shapes,

a shortest distance between the first pixel and the second pixel as well as a shortest distance between the first pixel and the third pixel is a same first length, and

a shortest distance between the first pixels is a second length that is longer than the first length and a shortest distance between each of the second pixels and the third pixels.

* * * * *