

Under the Paperwork Reduction Act of 1995, no persons are required to respond to a collection of information unless it displays a valid OMB control number.

PROVISIONAL APPLICATION FOR PATENT COVER SHEET – Page 1 of 2

This is a request for filing a PROVISIONAL APPLICATION FOR PATENT under 37 CFR 1.53(c).

Express Mail Label No. _____

| INVENTOR(S) | | |
|--|-------------------------------|---|
| Given Name (first and middle [if any]) | Family Name or Surname | Residence (City and either State or Foreign Country) |
| Yong Qin | Chen | 4097 Cortona Ct., San Jose, CA 95135 |
| | | |
| | | |
| | | |
| Additional inventors are being named on the _____ separately numbered sheets attached hereto. | | |
| TITLE OF THE INVENTION (500 characters max): | | |
| Wavelength Division Multiplexing Device for Extended Light Source | | |
| Direct all correspondence to: CORRESPONDENCE ADDRESS | | |
| <input type="checkbox"/> The address corresponding to Customer Number: <input type="text"/> OR <input checked="" type="checkbox"/> Firm or Individual Name Cytojene Corp. Address 4097 Cortona Ct. | | |
| City San Jose | State California | Zip 95135 |
| Country USA | Telephone 408-223-7722 | Email yqch@alum.mit.edu |
| ENCLOSED APPLICATION PARTS (check all that apply) | | |
| <input type="checkbox"/> Application Data Sheet. See 37 CFR 1.76 <input type="checkbox"/> CD(s), Number of CDs _____ | | |
| <input checked="" type="checkbox"/> Drawing(s) Number of Sheets 7 <input type="checkbox"/> Other (specify) _____ | | |
| <input checked="" type="checkbox"/> Specification (e.g. description of the invention) Number of Pages 16 | | |
| Fees Due: Filing Fee of \$250 (\$125 for small entity). If the specification and drawings exceed 100 sheets of paper, an application size fee is also due, which is \$310 (\$155 for small entity) for each additional 50 sheets or fraction thereof. See 35 U.S.C. 41(a)(1)(G) and 37 CFR 1.16(s). | | |
| METHOD OF PAYMENT OF THE FILING FEE AND APPLICATION SIZE FEE FOR THIS PROVISIONAL APPLICATION FOR PATENT | | |
| <input checked="" type="checkbox"/> Applicant claims small entity status. See 37 CFR 1.27. | | |
| <input type="checkbox"/> A check or money order made payable to the Director of the United States Patent and Trademark Office is enclosed to cover the filing fee and application size fee (if applicable). | | 125.00 |
| <input type="checkbox"/> Payment by credit card. Form PTO-2038 is attached. | | TOTAL FEE AMOUNT (\$) |
| <input type="checkbox"/> The Director is hereby authorized to charge the filing fee and application size fee (if applicable) or credit any overpayment to Deposit Account Number: _____ | | |

USE ONLY FOR FILING A PROVISIONAL APPLICATION FOR PATENT

This collection of information is required by 37 CFR 1.51. The information is required to obtain or retain a benefit by the public which is to file (and by the USPTO to process) an application. Confidentiality is governed by 35 U.S.C. 122 and 37 CFR 1.11 and 1.14. This collection is estimated to take 10 hours to complete, including gathering, preparing, and submitting the completed application form to the USPTO. Time will vary depending upon the individual case. Any comments on the amount of time you require to complete this form and/or suggestions for reducing this burden, should be sent to the Chief Information Officer, U.S. Patent and Trademark Office, U.S. Department of Commerce, P.O. Box 1450, Alexandria, VA 22313-1450. DO NOT SEND FEES OR COMPLETED FORMS TO THIS ADDRESS. **SEND TO: Commissioner for Patents, P.O. Box 1450, Alexandria, VA 22313-1450.**

If you need assistance in completing the form, call 1-800-PTO-9199 and select option 2.

CYTEK V. BECKMAN
PGR2025-00084
BECKMAN 2043

PROVISIONAL APPLICATION COVER SHEET
Page 2 of 2

PTO/SB/16 (09-11)
Approved for use through 05/31/2015. OMB 0651-0032
U.S. Patent and Trademark Office; U.S. DEPARTMENT OF COMMERCE

Under the Paperwork Reduction Act of 1995, no persons are required to respond to a collection of information unless it displays a valid OMB control number.

The invention was made by an agency of the United States Government or under a contract with an agency of the United States Government.
 No.
 Yes, the name of the U.S. Government agency and the Government contract number are: _____

WARNING:

Petitioner/applicant is cautioned to avoid submitting personal information in documents filed in a patent application that may contribute to identity theft. Personal information such as social security numbers, bank account numbers, or credit card numbers (other than a check or credit card authorization form PTO-2038 submitted for payment purposes) is never required by the USPTO to support a petition or an application. If this type of personal information is included in documents submitted to the USPTO, petitioners/applicants should consider redacting such personal information from the documents before submitting them to the USPTO. Petitioner/applicant is advised that the record of a patent application is available to the public after publication of the application (unless a non-publication request in compliance with 37 CFR 1.213(a) is made in the application) or issuance of a patent. Furthermore, the record from an abandoned application may also be available to the public if the application is referenced in a published application or an issued patent (see 37 CFR 1.14). Checks and credit card authorization forms PTO-2038 submitted for payment purposes are not retained in the application file and therefore are not publicly available.

SIGNATURE _____

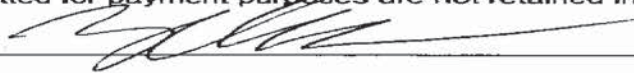

Date Oct. 18, 2012

TYPED or PRINTED NAME Yong Qin Chen

REGISTRATION NO. _____
(if appropriate)

TELEPHONE _____

Docket Number: _____

Wavelength Division Multiplexing Device for Extended Light Source

Abstract

A wavelength division multiplexing device for extended light source is provided. The device consists of a collimating optical element that produces an image of the light source and at least one imaging relay optical element. By designing the optical elements such that all images are of similar size to the effective size of the collimation optical element itself, the device provides a collimated light beam with small beam diameter and extended path length. Multiple dichroic filters may be inserted along the collimated optical path, picking up individual colored bands that can be focused down to small spots compatible with low noise optical detectors.

BACKGROUND OF THE INVENTION

[0001] 1. Field of the Invention

[0002] The present invention relates to a wavelength division multiplexing device for separating light beam from an extended light source into multiple colored bands for use in multicolor fluorescence spectroscopy applications such as in flow cytometry.

[0003] 2. Description of the Related Art

[0004] In many multicolor fluorescence detection instrumentations, such as flow cytometers, (Practical Flow Cytometry , Howard M. Shapiro , Wiley (2003)) ISBN 0471411256), the fluorescence light emitted from the object of interest is collected by a microscope objective, reimaged through a small pinhole or a multimode optical fiber, then collimated and separated into multiple colored bands and finally detected by photo detectors such as photomultiplier tube (PMT), PIN photodiode or avalanche photodiode (APD). PMT is essentially a special type of electron tube. The “pre-semiconductor age” device is bulky and expensive. In addition, it has poorer quantum efficiency and less reproducible spectral response than silicon based semiconductor detectors, particularly in the biologically important red to near infrared spectral region. Despite the disadvantages, PMT has excellent noise characteristics. For example, the dark current of a typical 13mm PMT (e.g., the R9305 from Hamamatsu Corporation of Japan) is only about 1nA. In contrast, an APD’s dark current would be 10 times greater even if its active area were reduced to 1/20th of the PMT. As a result, PMT has been the de-facto low-level light detector in many commercial fluorescence detection instrumentations. Only in certain scientific applications where event rate is low and dark current may be discriminated

against by expensive photon-counting techniques that PMT were replaced by APD detectors. (c.f., High-Throughput Flow Cytometric DNA Fragment Sizing, A.V. Orden, R.A. Keller, and W. P.Ambrose, *Anal. Chem.*, 2000, 72 (1), p 37–41). More recently, Geiger mode APD array was also promoted as PMT replacement. (For example, the multi-pixel photon counter of Hamamatsu Photonics of Japan and the solid-state photomultiplier of SensL Inc. of Ireland.) These detectors, however, also have high dark current and are nonlinear at high event rate.

[0005] The only industry where APD has found wide acceptance is in optical communication. It is known that if the APD's active area is reduced to less than 1mm^2 , the corresponding dark current will be reduced to the same level as a PMT. In optical communication, the light is a laser beam out of single mode optical fiber. Such a beam can be easily collimated then focused down to an area much smaller than 1mm^2 . It should be noted that the color separation devices used in the fluorescence light detection instruments, as detailed in US Pat. No. 6683314 and references therein, are almost identical in function and architecture to the wavelength division multiplexers (WDM) widely used in optical communication, as detailed in US Pat. No. 4482994, and US Pat. No. 5786915. One of the fundamental reasons prevented the use of small area APD in fluorescence detection instrumentation is the well known theorem of etendue conservation: the fluorescence light coming through a pinhole or multimode optical fiber is an extended light source with an etendue hundreds of times greater than that of a laser beam out of a single mode optical fiber. Consequently, as illustrated in figure 2, it cannot be collimated over an extended distance unless the diameter of the beam is significantly expanded. Unfortunately, the larger the beam diameter, the greater the technical

challenge to focus it down to a small spot. Since efficient color separation can only be accomplished economically with collimated light beam, small area APD was considered not viable for multicolor fluorescence light detection applications. Clearly, a technology capable of collimating a large etendue light beam over an extended distance without significantly expanding the beam diameter would be highly desirable. Such a technology would enable a WDM like device for fluorescence light detection with characteristics compatible to low noise semiconductor detectors.

SUMMARY OF THE INVENTION

[0006] Accordingly, it is an object of the present invention to provide a device capable of collimating a light beam from an extended light source over an extended distance without significantly expanding the said beam diameter. It is also an object of the present invention to provide a WDM system using the said device to separate the said light beam into multiple colored bands. Further, it is an object of the present invention to provide such a WDM system that is compatible with low noise semiconductor detectors. In addition, due to the diversity of fluorescent probes, it is an object of the present invention to provide such a WDM system that is reconfigurable.

[0007] A device in accordance with the present invention, generally includes at least two optical elements. The first said element is used to collimate an extended light source, such as the light through a pinhole or multimode optical fiber. It magnifies the said extended light source, for example, as defined by the said pinhole, or the core of the multimode optical fiber, to an image of similar size to the effective cross section of the said first optical element, thus creates a collimated light beam between the said first optical element and its image. The said second optical element is positioned near the said

image, and relays the said first optical element with unit magnification down the optical path, therefore effectively doubles the collimated path length. Additional optical elements in the same 1:1 image relay configuration may also be included in the present invention to further extend the collimated optical path. The cascaded unit-magnification image relay architecture of the present invention provides a means to greatly extend the collimated optical path length without large beam expansion. As a result, WDM technologies well-established in the optical communication industry can be readily adapted for fluorescence light detection. In particular, multiple colored bands can be separated using dichroic filters along the optical path and tightly focused into small spots compatible with low noise semiconductor detectors.

[0008] In one exemplary embodiment of the present invention, the said first optical element is a lens and the said second element is a concave mirror, although it is apparent to those skilled in the art that other types of refractive and/or reflective optical components may also be used to achieve the same design goal. Similar to its counterpart in optical communication, the optical path in an WDM device of the present invention may be folded using dichroic filters. In one exemplary embodiment of the present invention, the light path is folded into a zigzag. Each said filter is then epoxy bonded to a mechanical holder containing a reference surface that is optically parallel to the reflective surface of the said filter. As a result, all filters can be accurately placed into the optical path by referencing them against a common optical flat, providing a reliable means for reconfiguration.

[0009] In another exemplary embodiment of the present invention, the collimated beam passing through the dichroic filter is further branched out into multiple colored bands

using secondary dichroic filters. It is apparent to those skilled in the art that dichroic filters may be inserted anywhere along the long, narrow and collimated beam path afforded by the relay imaging of the present invention, providing the means to deliver tightly focused beam to photo detectors using a variety of optical configurations, such as the star configuration discussed in US Pat. No. 6683314, the branched configuration discussed in US Pat. No. 4727020 and other types of WDM optical configuration widely practiced in the optical communication industry. The concave mirrors may also be replaced by curved dichroic filters to further increase the number of colored bands supported by a WDM device of the present invention.

BRIEF DESCRIPTION OF THE DRAWINGS

[0010] Fig. 1 illustrates the optical ray trace for an exemplary 6 ports wavelength division multiplexer of the present invention using zig-zag configuration.

[0011] Fig. 2 shows the optical ray trace of the prior art collimating device illustrating its limitation in collimating an extended light source.

[0012] Fig. 3 shows a 3-dimensional view of an alternative exemplary embodiment of 6 ports wavelength division multiplexer of the present invention using a combination of zig-zag and branched configurations.

[0013] Fig. 4 shows a 3-dimensional view of an exemplary wavelength division multiplexer of the present invention with concave dichroic filters.

[0014] Fig. 5 are schematics illustrating an exemplary template and assembly process to construct replaceable dichroic filters for an exemplary reconfigurable wavelength division multiplexer of the present invention.

[0015] Fig. 6 are schematics illustrating the placement of replaceable dichroic filters in an exemplary reconfigurable wavelength division multiplexer of the present invention.

DETAILED DESCRIPTION

[0016] Figure 1 shows the optical ray trace for an exemplary 6 ports wavelength division multiplexer of the present invention using zig-zag configuration. As shown in the figure, fluorescence light going through a pinhole or emitted from the facet of a multimode optical fiber forms an extended object or light source at location 1. The size of the said object is defined by the diameter of the said pinhole or the core diameter of the said multimode optical fiber. Note that the practical size of the said pinhole or the core diameter of the said multimode optical fiber is measured in millimeter, in contrast to the diameter of single mode optical fiber measured in micrometer. Consequently, the etendue of the fluorescence light source, defined as the product of beam size and its divergence angle, is hundreds times greater than its counterpart in optical communication. According to the theorem of the conservation of etendue (Julio Chaves, *Introduction to Nonimaging Optics*, CRC Press, 2008 [ISBN 978-1420054293]), light from such an extended source, similar to that from a flash light, can only be kept collimated for a very limited distance, particularly when the diameter of the collimated portion needs to be small. As shown in figure 1, an collimating optical element, in this case an achromatic doublet lens 2, captures the light from source 1, and projects a magnified image of the said object near one of the final focusing lens 5. The size of the said image near 5 is kept significantly the same as the effective size of the said collimating optical element 2. Consequently, the beam between 2 and 5 are significantly collimated. As shown in the figure, as long as the magnification factor is kept small, for example, less than around 10, the said image can

be readily focused down to a spot smaller than that of the said light source at 1 using a simple singlet lens, enabling the placement of a small area semiconductor detector at the focal point 6 of the said focusing lens 5 for efficient photo detection. A dichroic filter 3, is inserted into the optical path approximately midway between the said collimating optical element 2 and the said image 5 at a slanted angle. The said filter is designed to pass the color band of interest and reflect the remaining colors in the light beam for further processing. An optional band pass filter 4 may be inserted following the dichroic 3 to further improve the color isolation capability of the device. A second optical element 7, in the exemplary embodiment of the present invention a concave mirror with radius of curvature significantly equal to the distance between the said collimating optical element 2 and the said image near focusing lens 5, catches the reflected beam. The said second collimating optical element 7 therefore creates a second image of the collimating lens 2 near the second focusing lens 8. The light beam between the said mirror 7 and the said second image is of significantly the same diameter as that between the said collimating lens 2 and the said first image near the said focusing lens 5. The relay imaging element 7 therefore effectively doubles the collimated beam path without expanding the beam diameter. Again, the extended yet collimated beam can be easily focused down to a spot smaller than that of the said light source at 1. A second dichroic mirror 9 is then inserted significantly midway between the relay imaging element 7 and the second image near focusing lens 8. The said second dichroic 9 would let pass another band of color in the light beam and reflect the remaining for further processing. As shown in figure 1, additional relay collimating optical elements 10, 11, 12, 13 and dichroic filters 14, 15, 16, 17 can be cascaded using the same strategy, producing

multiple images near focusing lenses 18, 19, 20 and 21, each corresponds to a specific color band of the light source. As shown in the figure, due to the 1:1 imaging relay architecture of the present invention, the focal spots produced by focusing lenses 6, 8, 18, 19, 20 and 21 are all smaller than the source, therefore can be easily captured by small area APD's. Although the exemplary embodiment of the present invention shows a 6-port wavelength division multiplexer for extended light source, it is apparent to those skilled in the art that WDM's with different number of port counts can be easily created using the same design principle. It is also apparent to those skilled in the art that although the exemplary embodiment of the present invention uses achromatic doublets as the first collimating optical element, singlet lens can also be used since the images created before the focusing lens 6, 8, 18, 19, 20 and 21 are all nearly monochromatic. Instead of using concave mirrors as the secondary relay collimating optical elements, one may also use refractive optics as relay element to extend the collimated light path. One clear advantage of the zig-zag architecture of the exemplary embodiment of the present invention, however, is the possibility to use array detectors, which would lead to compact detector modules suitable for portable instrumentation.

[0017] Figure 2 shows the optical ray trace of a prior art collimating device. The technique is extensively used in conventional multicolor fluorescence instrumentations, for example, in US Pat. No. 6683314. As shown in the figure, the light beam diverges rapidly beyond the image 24 created by the collimating optical element 23. Consequently, the only option to construct a multi-color device is to insert dichroic filters in between the collimating element 23 and its image 24. Due to the constraint of etendue conservation, the diameter of the collimated beam must be significantly expanded to fit multiple

dichroics in the section. The expanded beam creates serious challenge to refocus the collimated beam down to small spots suitable for small area semiconductor detectors. To overcome the challenge, some instrument manufacturers opted to use PMT's exclusively for fluorescence detection, such as in the main stream flow cytometers manufactured by Becton-Dickinson, Becman Coulter and Partec 's and the MegaBACE series of DNA sequencer by GE Amersham. Others cherry-picked certain color bands with known bright fluorescence, and uses large area APD for those channels, such as the Luminex multiplexed bead analyzers.

[0018] Figure 3 shows a 3-dimensional view of an alternative exemplary embodiment of a 6-port wavelength division multiplexer of the present invention using a combination of zig-zag and branched configurations. The design is a modification of zig-zag architecture shown in figure 1. Here the band pass filter 4 of figure 1 is replaced by a dichroic filter 4'. The filter 4' is positioned to let one color to pass through and the other color to be reflected at 90 degree. The optical path length of the beam passing through the dichroic 4' and that being reflected by 4' are substantially the same, such that one arm is focused by lenses 5 and the other by lens 5' to small spots compatible with small area semiconductor detectors placed at focal location 6 and 6'. As shown in the figure, the remaining color of the light reflected by dichroic filter 3 is relay imaged by a concave mirror 7 and the configuration including optical elements 3, 4', 5 and 5' is cascaded 2 more times to form a 6 port-WDM.

[0019] Figure 4 shows a 3-dimensional view of another exemplary embodiment of an 8-port wavelength division multiplexer of the present invention. By replacing the concave

relay imaging mirrors 7 and 10 in figure 3 with concave shaped dichroic filters 7' and 10', the WDM will support 2 more color bands.

[0020] Numerous fluorescence probes have been developed over the years. More recently, multiple fluorescence proteins also become an important tool in biomedical studies. To accommodate the different types of fluorescence probe, various techniques have been introduced to enable users to replace the dichroic filters to fit their needs. One of the main challenges to replace filter is to avoid direct contact of the coated filter surface with any hard reference frame. Otherwise, the coated optics may be damaged during repeated replacement. Most of the conventional solutions today rely on precision-machined mechanical spacers to hold the filters in place. One example is given in US Pat. No. 6683314. Such techniques, however, are no longer reliable when the active area of the detector is reduced to below 1mm^2 . Figure 5 shows an exemplary embodiment of the present invention for the fabrication of a replaceable dichroic filter suitable for small area detectors. Figure 5a shows the construction of a reference template for the fabrication of the replaceable filter. The template is a staircase made of 2 optically parallel glass plates 25 and 26. When the two said plates are bounded together using optical contact, the surface 29 of the said glass plate 25 is optically parallel to surface 30 of the said plate 26. The front surface 32 of the dichroic filter 27 is then pressed against surface 29 of the said template. A filter holder 28 is machined that contains a reference surface 31 and a filter slot 33 which loosely fits the filter 27. During assembly, the filter slot 33 is partially filled with epoxy and the reference surface 31 of the holder 28 is pressed against surface 30 of the template while the holder 28 is slide towards filter 27. The epoxy is then solidified after part of the filter is seated inside the holder slot 33 while

pressure is still applied against the said filter and holder. It should be apparent to those skilled in the art that the epoxy may be either UV or thermal curable or made of A/B mixture. Figure 5c shows a dichroic filter assembled using the said process. The process guarantees that surfaces 32 of the filter assembly 34 will be optically parallel to the reference surface 31, and indented with respect to the latter at a spacing accurately determined by the thickness of the glass plate 25.

[0020] Figure 6 shows one exemplary embodiment of the present invention where the fore-mentioned replaceable dichroic filter assembly 34 is implemented in a WDM device for extended light source. A notable feature contained in the exemplary embodiment of the WDM of the present invention is a glass reference block 35 with an optically flat surface, although it is apparent to those skilled in the art that the said block may be made of other materials. As shown in the figure, during the filter replacement, the reference surface 31 of the dichroic filter assembly 34 slides against the said flat surface and is kept in contact with the optical flat by a spring loaded screw 36. Consequently, the coated surface 32 of the dichroic filter assembly 34 is always optically parallel to the said optical flat and accurately located. In the meantime, the indentation of surface 32 with respect to the reference surface 31 protects it from in physical contact with any object during filter replacement.

[0021] It is apparent to those skilled in the art that many modifications and variations of the described embodiments of replaceable dichroic filter assemblies are possible. For example, figure 7 shows an alternative exemplary embodiment of the present invention. Here the template is a pedestal made of 2 optical flats 38 and 39 of round shape. During assembly, the reference surface of the filter holder 40 will rest against the surface of 38

and the coated surface of the filter 37 rest against the flat surface of 39. Epoxy bounding then holds the coated surface of filter 37 to be optically parallel to the reference surface of the holder 40, yet indented at a distance accurately determined by the thickness of the optical flat 39.

[0022] Although an exemplary embodiment of the present invention of wavelength division multiplexing device for separating light beam from an extended light source into multiple color bands has been described in some detail, and several other equally advantageous embodiments have also been described, it will be apparent to those ordinary skilled in the art that many modifications and variations of the described embodiments are possible in the light of the above teachings without departing from the principles and concepts of the invention as set forth in the claims.

What is claimed is:

1. A wavelength division multiplexing device for separating light beam from an extended light source into multiple colored bands, comprising:
 - a) A collimating optical element means that magnifies an extended light source to produce an image of significantly the same size as the effective size of the said collimating optical element means.
 - b) At least one dichroic filter means placed in between the said collimating optical element means and the said image, wherein the said dichroic filter means separates the collimated light beam into two branches of distinctive colors.
 - c) A focusing optical element means placed in one of the said branches,

wherein the light beam of the said branch is focused to a spot less than 1 mm diameter by the said focusing optical element means.

- d) An image relay optical element means located near the image produced by the said collimating optical element means in the other said branch, wherein the said image relay optical element means produces an image of the said collimating optical element means at significantly unit magnification.
2. A wavelength division multiplexing device of claim 1, wherein at least one additional dichroic filter means is placed in between the said image relay optical element means and the image produced by the said image relay optical element means, wherein the said dichroic filter means produces 2 branches of light beam of distinctive colors.
3. A wavelength division multiplexing device of claim 2, wherein another focusing optical element means is placed in one of the said branches and focuses the light beam of the branch into a spot of less than 1 mm diameter.
4. A wavelength division multiplexing device of claim 3, wherein the architecture of image relay optical element means, dichroic filter means and focusing optical element means is cascaded to produce additional focused spots of less than 1 mm diameter for multiple color bands of the said light source.
5. A wavelength division multiplexing device of claim 3, wherein the dichroic filter assembly means is made using a template means consisting of 2 optically flat glass plate means bounded together by optical contact, wherein the filter means is epoxy bonded to the holder means of the said assembly means using the template means such that the coated filter surface of the dichroic filter means is indented

- and optically parallel to the reference surface of the filter assembly means.
6. A wavelength division multiplexing device of claim 5, wherein the reference surface of the dichroic filter assembly means rests against an optically flat surface of an reference block means contained in the device, providing consistent optical alignment during filter replacement.
 7. A method for separating light beam from an extended light source into multiple colored bands using a wavelength division multiplexing device comprising
 - a) A collimating optical element means that magnifies an extended light source to produce an image of significantly the same size as the effective size of the said collimating optical element means.
 - b) At least one dichroic filter means placed in between the said collimating optical element means and the said image, wherein the said dichroic filter means separates the collimated light beam into two branches of distinctive colors.
 - c) A focusing optical element means placed in one of the said branches, wherein the light beam of the said branch is focused to a spot less than 1 mm diameter by the said focusing optical element means.
 - d) An image relay optical element means located near the image produced by the said collimating optical element means in the other said branch, wherein the said image relay optical element means produces an image of the said collimating optical element means at significantly unit magnification.
 8. A method of claim 7, wherein at least one additional dichroic filter means is placed in between the said image relay optical element means and the image

produced by the said image relay optical element means, wherein the said dichroic filter means produces 2 branches of light beam of distinctive colors.

9. A method of claim 8, wherein another focusing optical element means is placed in one of the said branches and focuses the light beam of the branch into a spot of less than 1 mm diameter.
10. A method of claim 9, wherein the architecture of image relay optical element means, dichroic filter means and focusing optical element means is cascaded to produce additional focused spots of less than 1 mm diameter for multiple color bands of the said light source.
11. A method of claim 9, wherein the dichroic filter assembly means is made using a template means consisting of 2 optically flat glass plate means bounded together by optical contact, wherein the filter means is epoxy bonded to the holder of the said assembly means using the template means such that the coated filter surface of the dichroic filter means is indented and optically parallel to the reference surface of the filter assembly means.
12. A method of claim 11, wherein the reference surface of the dichroic filter assembly means rests against an optically flat surface of an reference block means contained in the device, providing consistent optical alignment during filter replacement.

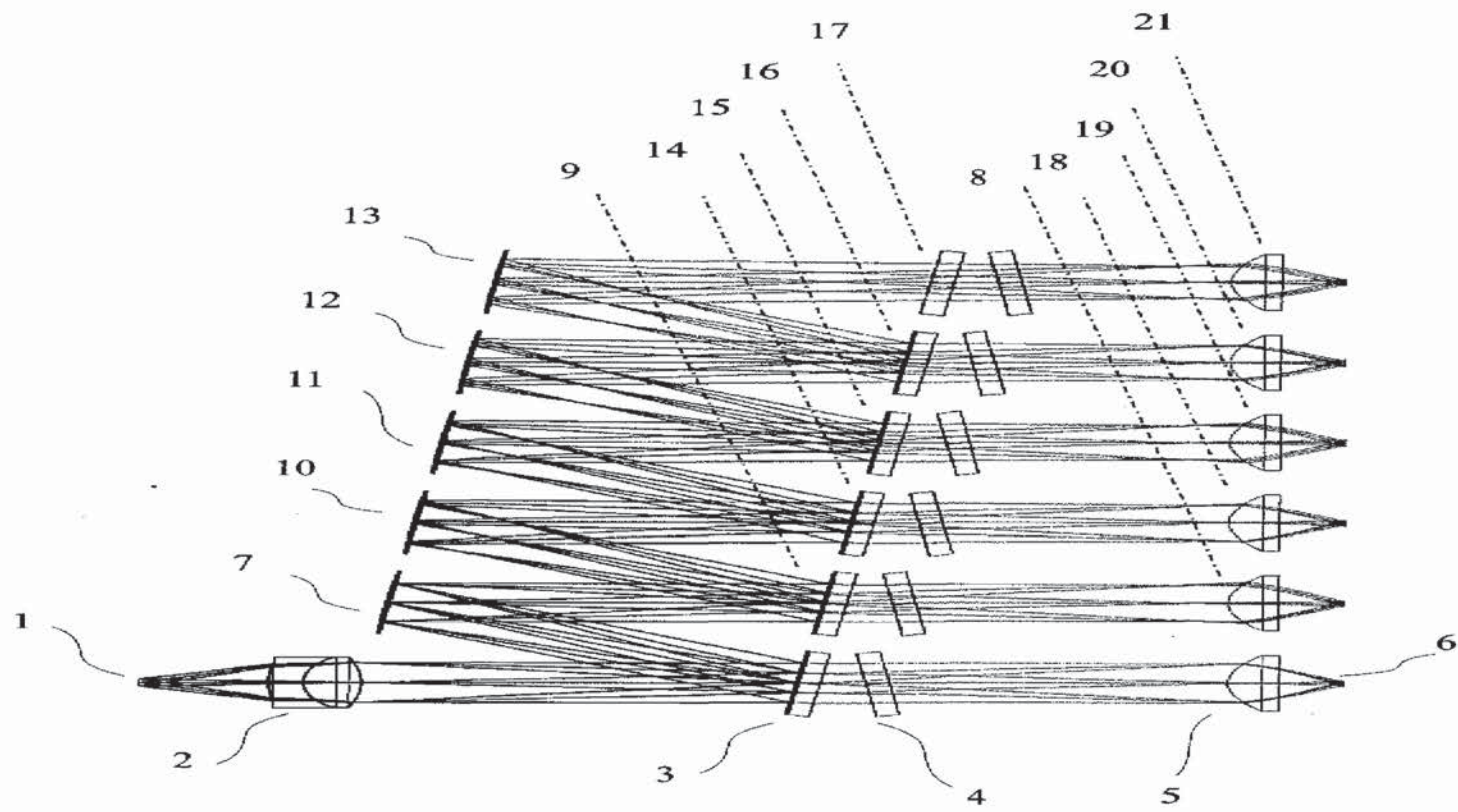

Figure 1

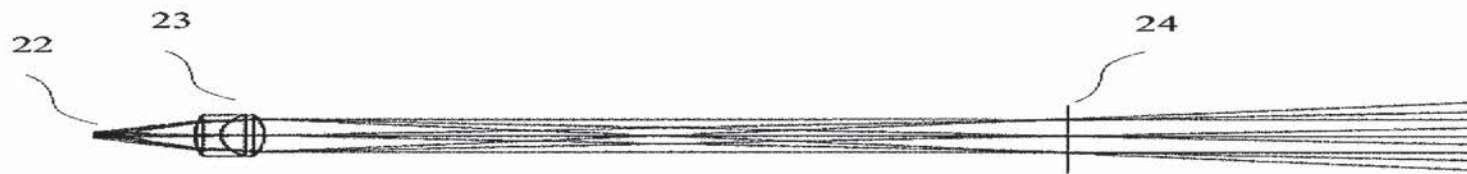

Figure 2

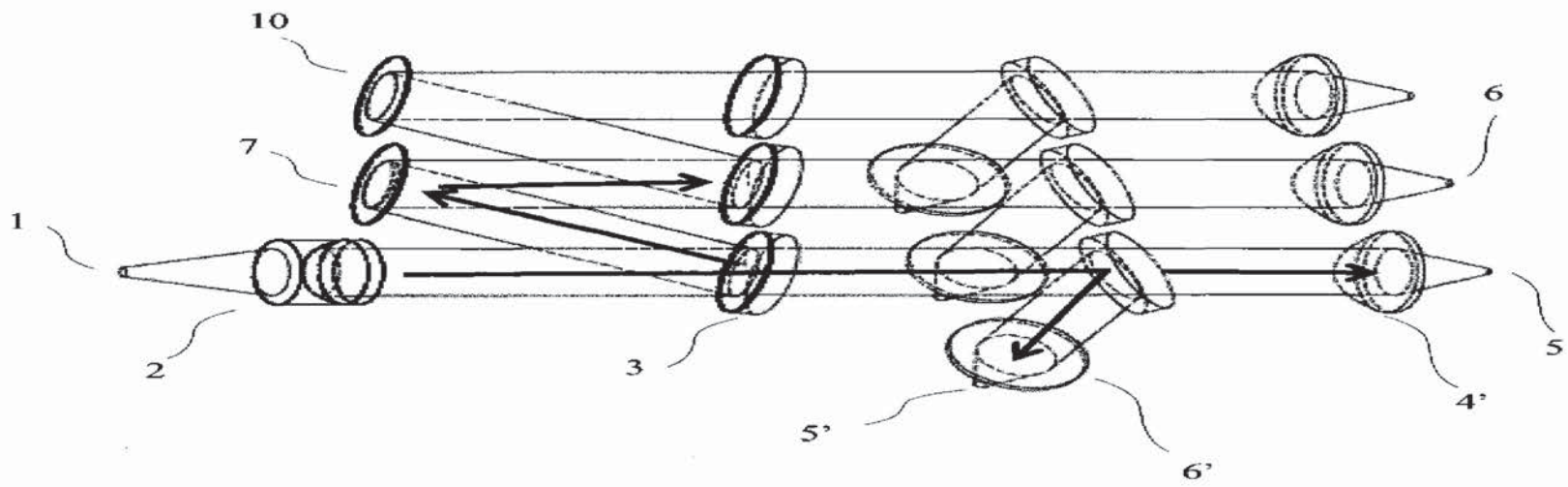

Figure 3

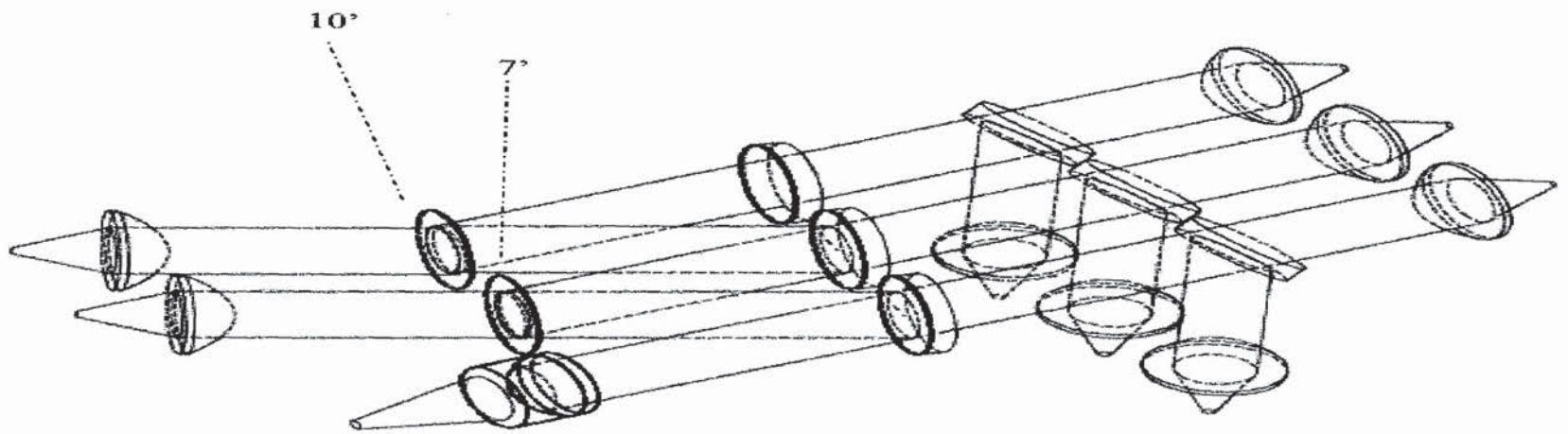

Figure 4

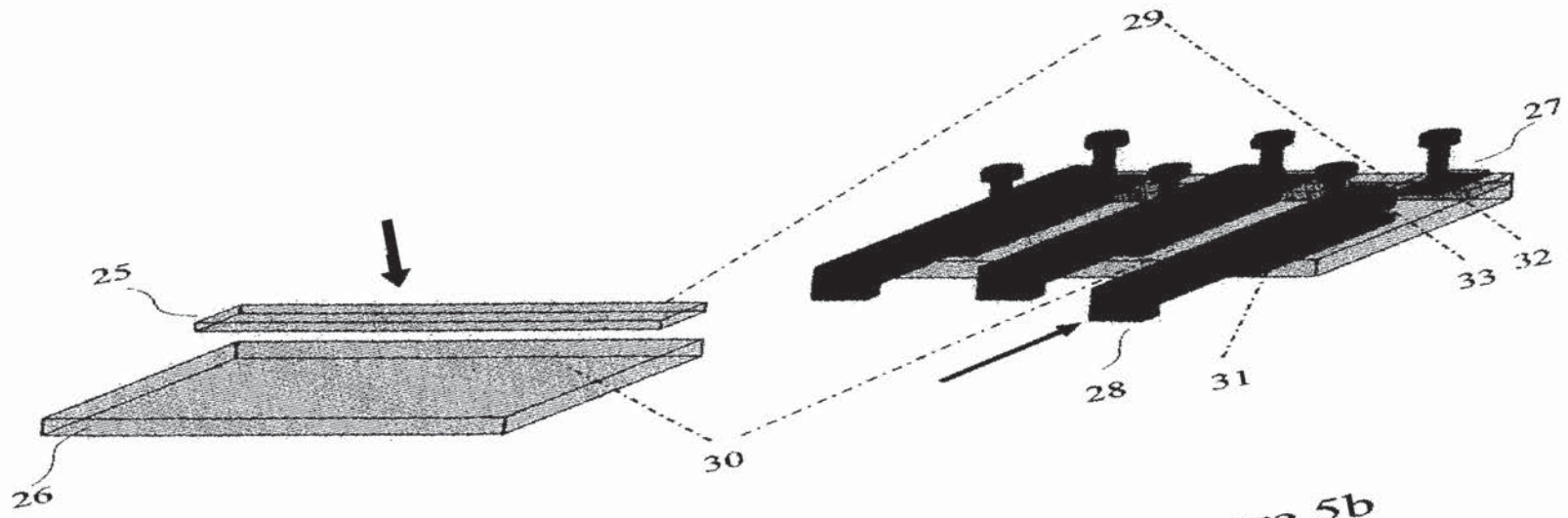

Figure 5b

Figure 5a

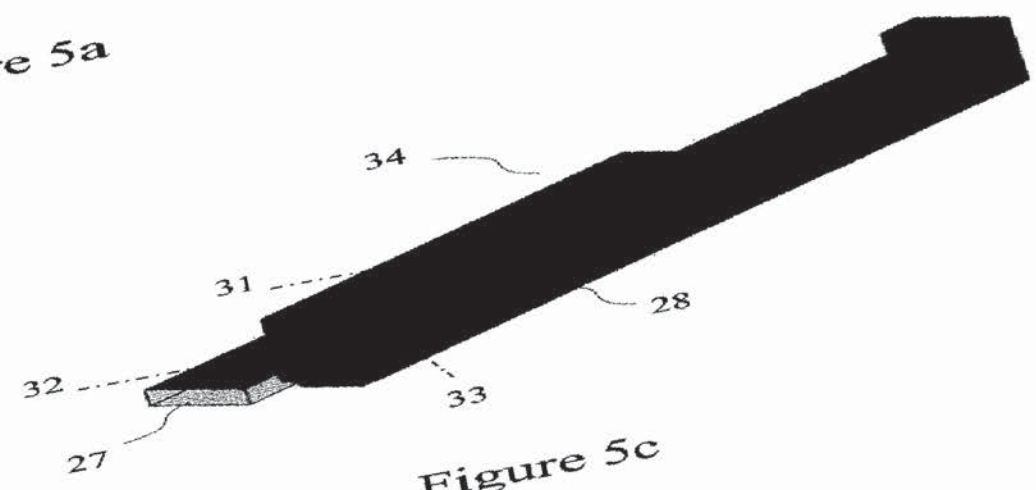

Figure 5c

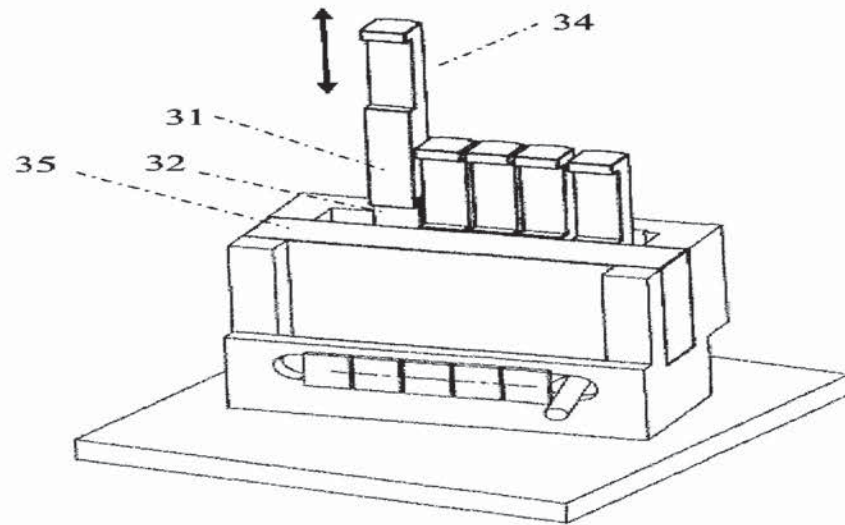

Figure 6a

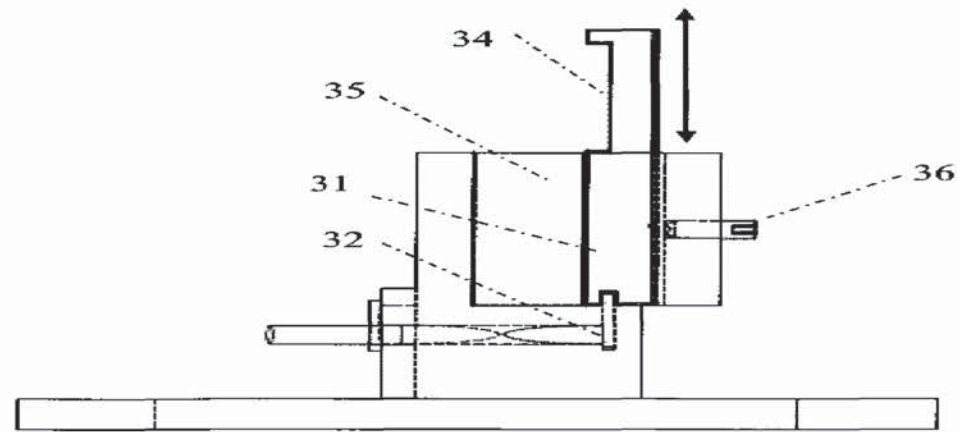

Figure 6b