

Bluetooth



Direct conversion CMOS RF transceiver

Multimedia embedded SOC bringing outstanding flexibility

Ultimate development environments supported
beyond the limits of applications

- Standard Silicon Solution (GDM1000/1201)
- Multimedia SOC for Digital Audio Streaming (GDM1202)
- True CMOS Single Chip RF/Baseband (GDM1101)
- GCT Bluetooth Development Kit (GBLUE-Kit)



Key Features

Highly-Integrated CMOS RadioTransceiver (GDM1000)

- Class 2 and 3 (1 to 10 meter range) compliant with Bluetooth Specification 1.1
- Fully integrated, single-chip transceiver with on-chip PLL, VCO, LNA, PA, up/down converter, and digital GFSK modem with symbol timing recovery, bit-slicer, SYNCWORD detector
- BlueRF RXMODE2/3 unidirectional and JTAG serial interfaces , compatible with GDM1201 baseband IC
- -80dBm minimum receiver sensitivity
- Superior adjacent channel selectivity (C/I -6dB@1MHz offset frequency)
- High out-of-band blocking immunity
- Support for dual reference clock frequency: 13/16MHz
- 0.25 μ m RFCMOS technology
- 44-pin QFN (7mm x 7mm) package

General Bluetooth Baseband supporting multiple - standards, along with USB host/device combo functions (GDM1201)

- Compliant with Bluetooth Specification 1.1
- Programmable seamless Bluetooth RF interfaces such as 6 wires BlueQ interface or BlueRF RXMODE2/3 uni/bi-directional and JTAG serial interfaces compatible with GDM1000 radio transceiver IC
- Standard UART, USB with host/device combo functions and 13/14bit PCWCVSD, 8kbps synchronous serial audio interfaces
- Integrated 14bit 8kbps sigma delta analog voice codec
- Integrated 64MIPS PiCOII-RISC GCT embedded RISC processor and 64Kbyte on-chip SRAM
- On-chip implementation of Link Controller, Link Manager, HCI, L2CAP, RFCOMM, and common Bluetooth profiles
- Provides system power control of radio and microprocessor
- Software development kit and source code licenses available
- Supports multiple reference clock frequency: 12/13/16/19.2MHz
- 0.18 μ m CMOS technology
- 100-pin fpBGA (8mm x 8mm) package

GCT provides a fully functional Bluetooth ICs for data and voice communications with highly-integrated software solutions. The standard Bluetooth chipset provided by GCT is comprised of the GDM1000 2.4GHz radio transceiver IC and GDM1201 single chip baseband controller.

Applications

- Bluetooth modules
- Mobile hand-held devices
- Access points
- PCMCIA

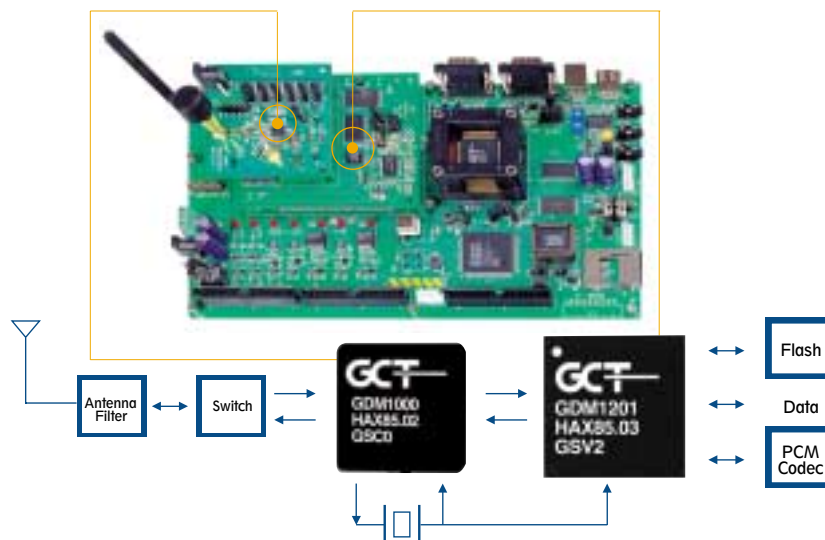

GDM1201

- The GDM1201 is a single-chip baseband controller implemented with CMOS technology providing Bluetooth functionality for high data rate, short distance wireless communication in the 2.4GHz ISM band. Together with the GDM1000 radio transceiver IC and external flash memory, it provides a fully compliant Bluetooth solution for data and voice communications.
- The on-chip 32-bit microcontroller supports the highest data rate in Bluetooth communications. The architecture of GDM1201 is based on GCT's proprietary embedded RISC processor for low power processing and includes sufficient embedded SRAM (64Kbyte) to support the on-chip Bluetooth stack, such as Link Controller, Link Manager, HCI, L2CAP, RFCOMM and SDP, thus allowing cost-effective embedded or hosted application solutions.
- GDM1201 supports multiple-standard interfaces, such as BlueRF RXMODE2/3 uni/bi-directional, BlueQ and JTAG serial, which can simplify implementation with alternate vendors' transceivers, giving the customers outstanding flexibility.

GDM1000

- The GDM1000 Bluetooth single-chip CMOS radio is a highly integrated RF transceiver and modem optimized for use in 2.4GHz Bluetooth communication systems. With on-chip PLL, VCO, and all the other function elements of transmitter and receiver, the GDM1000 provides a very high integration level, thus requiring only an external antenna, antenna switch, and crystal for a complete Bluetooth v1.1 RF solution.
- This radio IC is based on GCT's patented direct conversion architecture, which offers superior adjacent channel selectivity and fast automatic gain control and reduces the number of external RF board components such as external SAW filters, bandpass filters and on-chip inductors, thus meeting stringent requirements of smallest form factor in Bluetooth. The radio is implemented in a production-ready, high-yield CMOS processes, further enhancing its cost-competitiveness.
- GDM1000 supports the standard BlueRF RXMODE2/3 unidirectional and JTAG serial interfaces, which allow integration with a variety of different vendors' baseband ICs allowing a high degree of system design flexibility.

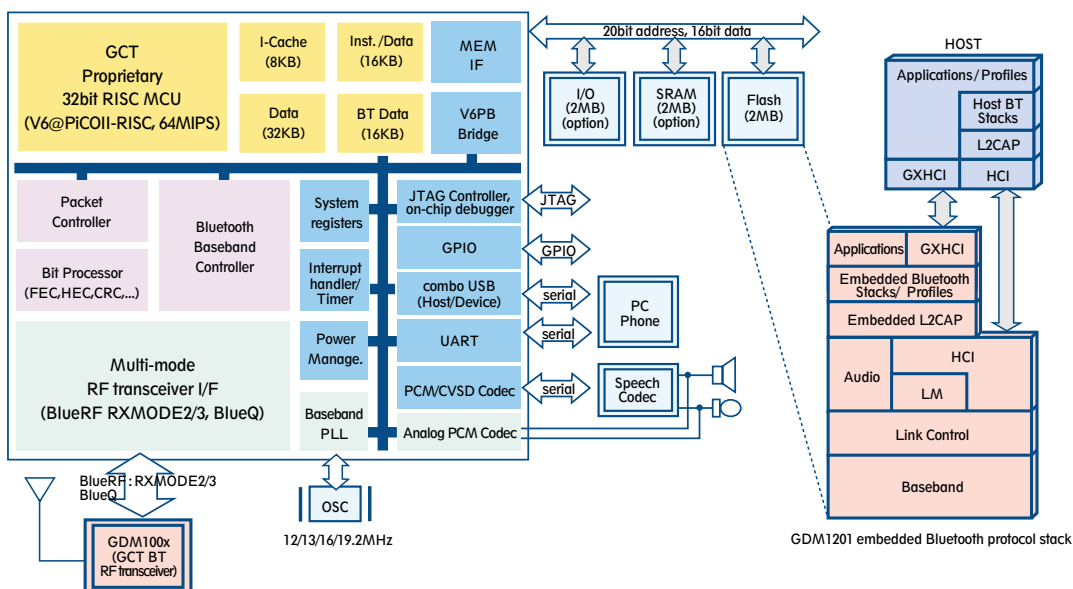
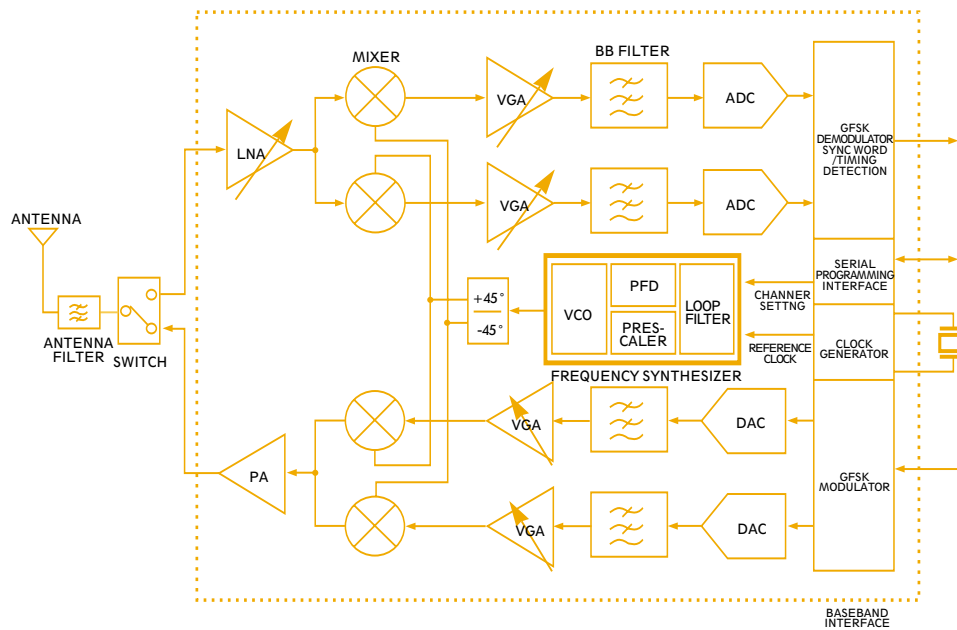

Key Features

- Compliant with Bluetooth Specification 1.1
- Programmable seamless Bluetooth RF interfaces such as 6 wires BlueQ interface or BlueRF RXMODE2/3 uni/bi-directional and JTAG serial interfaces compatible with the GDM1000 radio transceiver IC
- Standard UART, USB with device/host combo functions, 13/14bit 8KHz PCM/CVSD, and I²S two channels external audio DAC interfaces
- Integrated sigma delta analog combo codec with the functions supporting both 16bit 8kbps voice codec and 16bit programmable 32/44.1/48KHz sampling frequency dual channel audio DAC
- GCT's proprietary 96MIPS hybrid RISC and DSP PIC011 embedded processor with 24-bit multiplication and 48-bit accumulation and 128Kbyte on-chip SRAM, sufficient to support several digital audio and speech codecs such as MP3, AC3 or G.723.1
- On-chip implementation of Link Controller, Link Manager, HCI, L2CAP, RFCOMM and A/V transport profile for digital audio streaming applications
- Software development kit and source code licenses available for embedded stacks, and DSP firmware available for audio and speech standards
- Supports multiple reference clock frequencies: 12/16/19.2MHz
- 0.18 μ m CMOS technology



The GDM1202 is a single chip Bluetooth baseband IC implemented in CMOS technology with embedded DSP processor for Bluetooth applications, such as MP3 or AC3 digital audio decoders. Together with GDM1000 2.4GHz radio transceiver IC and an external flash memory, it provides a fully compliant Bluetooth solution, especially for digital audio streaming. The GDM1202 is comprised of a radio interface, Bluetooth baseband for bit processing, on-chip 32-bit hybrid RISC/DSP embedded processor, and standard peripheral interfaces.

GDM1202

- The GDM1202 is focused on audio streaming applications, allowing high-quality audio content distribution. GDM1202 supports the Advanced Audio Distribution Profile defined in Bluetooth with internal audio DAC. For a complete Bluetooth solution, the GDM1202 can be integrated with the GDM1000 2.4GHz radio transceiver, needing only an external antenna, crystal and flash memory.
- The on-chip embedded processor in GDM1202 is based on GCT's proprietary hybrid RISC/DSP processor and is powerful enough to support both full rate Bluetooth data/voice communications and computational intensive DSP applications. With 128Kbytes of internal SRAM, it supports both an on-chip Bluetooth stack, [including LMP, L2CAP, SDP, AVDTP (A/V Distribution Transport Protocol) and AVCTP (A/V Control Transport Protocol)], and an audio application without external memory, thus providing a cost-effective, low-power solution.
- GDM1202 supports GCT's optimized C compiler and intrinsic library functions to maximize developer's software development productivity. On top of this, GCT provides a performance-optimized DSP library for enabling several multimedia standards, such as MPEG audio decompression, Dolby Digital decompression, G.723.1/G.728 speech codec, etc.

Applications

- Portable MP3 players
- Wireless short range digital audio streaming system
- Wireless high quality digital audio speaker system

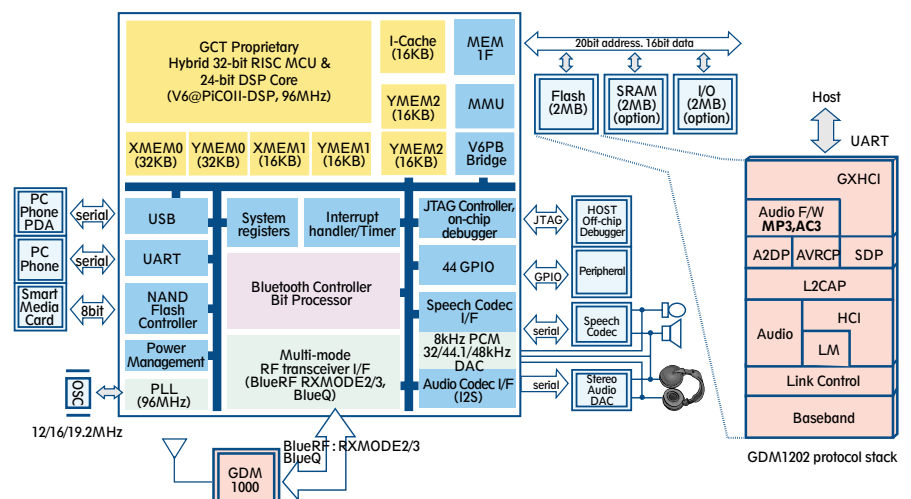

GDM1101 is a Bluetooth single-chip CMOS IC with integrated radio transceiver and baseband controller providing a complete Bluetooth version 1.1 solution (excluding external flash memory). GDM1101 consists of a radio transceiver employing GCT's patented direct conversion technology, baseband controller with bit processor, GCT's proprietary embedded RISC processor, and standard peripheral interfaces such as UART/USB/PCM.

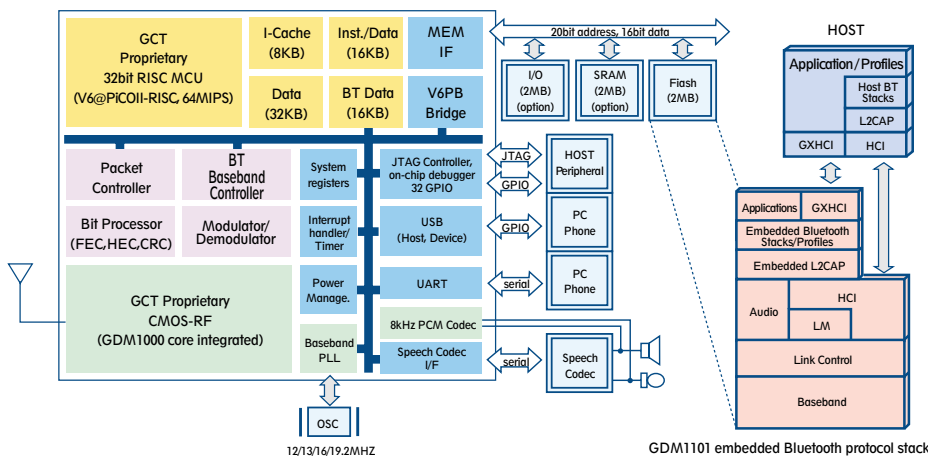

Key Features

- Class 2 and 3 (1 to 10 meter range) compliant with Bluetooth v1.1
- Fully integrated, radio transceiver with on-chip PLL, VCO, LNA, PA, up/down converter, and digital GFSK modem
- -80dBm minimum receiver sensitivity
- Standard UART and 13/14bit PCM, 8KHz synchronous serial audio interfaces
- USB interface compliant with USB Specification 1.1 supporting both host and device functions
- Integrated 14bit 8kbps sigma delta analog voice codec
- GCT's proprietary 64MIPS PiCOII-RISC embedded RISC processor and 64Kbyte on-chip SRAM
- On-chip implementation of Link Controller, Link Manager, HCI, L2CAP, RFCOMM and common Bluetooth profiles
- Provides system power control of radio and microprocessor
- Software development kit and source code licenses available
- Supports multiple reference clock frequency: 12/13/16/19.2MHz
- 0.18 μ m RFCMOS technology

GDM1101

- With GCT's patented direct conversion technology minimizing LO coupling and DC offsets, the GDM1101 surpasses Bluetooth 1.1 performance requirements, especially for high channel selectivity and broad dynamic range, thus providing reliable and superior performance in the presence of many ISM band RF interferers.
- The on-chip 32-bit RISC processor is powerful enough to support full rate Bluetooth communications. Its instruction set is optimized for bit processing in embedded solutions or voice applications, which are frequently used in Bluetooth.
- With 64Kbytes of internal SRAM, the GDM1101 effectively supports on-chip Bluetooth stack without using any external memory, which results in lower power consumption and a more cost effective solution for embedded or hosted Bluetooth applications.

Applications

- ISM 2.4GHz wireless applications
- Personal wireless communication systems
- Mobile hand-held devices with small form factors

GCT Bluetooth Development Kit (GBLUE-Kit)

GCT provides a complete development kit for implementing Bluetooth software and hardware applications along with silicon solutions, which are also supported by GCT. GBLUE-Kit, GCT Bluetooth Development Kit, is designed for professional developers targeting both host software and on-chip applications.

<GBLUE-Kit>

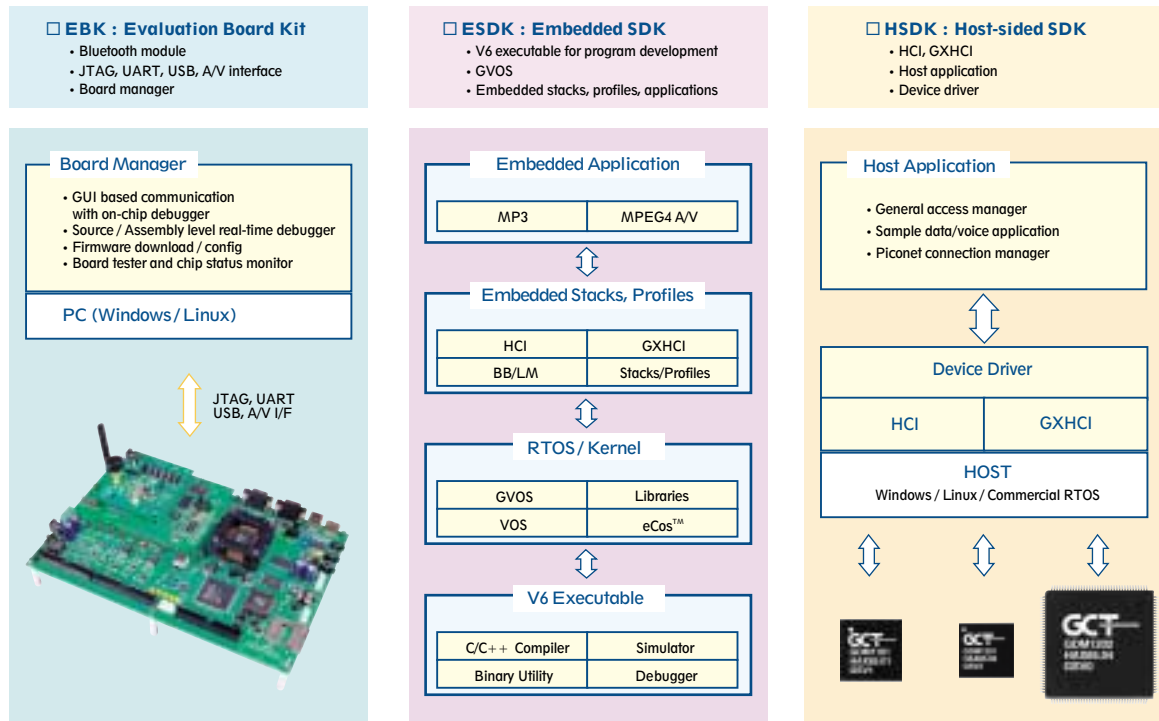

Customer Development Support

GCT supports complete tools for customized applications, which have been evolving from a basic standardized approach.

<Evolutionary Approach >

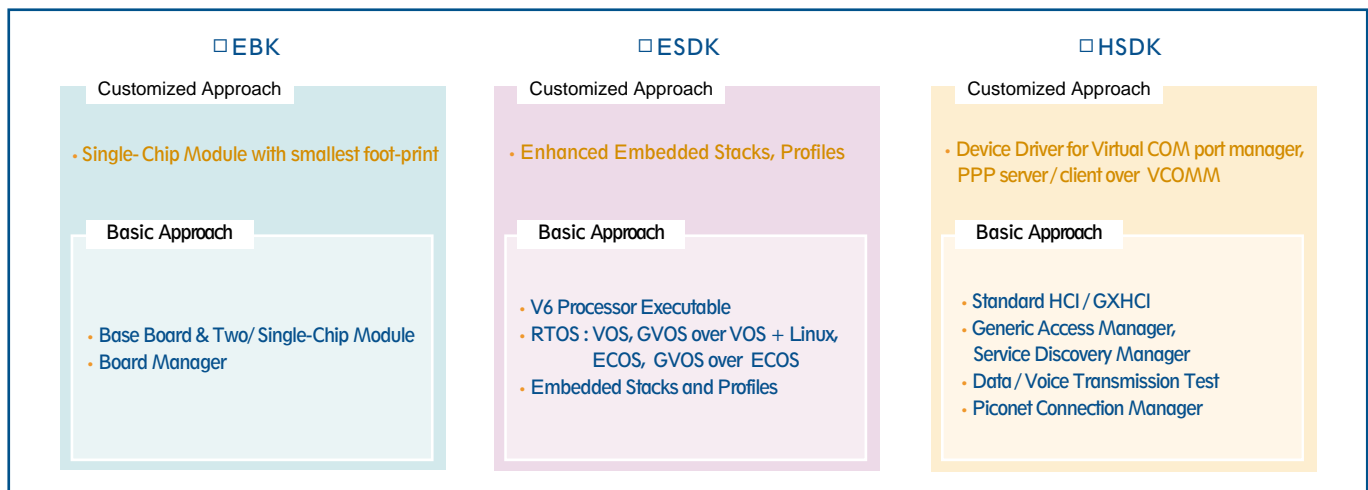

GBLUE-EBK

- Bluetooth modules in the EBK includes:
 - 2-chip: GDM1000 & GDM1201
 - 1-chip: GDM1101
- Bluetooth evaluation board manager software
 - On-chip processor GUI debugger with both source and assembly level
 - Firmware downloading and configuration
 - Diagnostic operation of both evaluation board and chip



GBLUE-HSDK

- HSDK (Host-sided SDK) enables customers to develop their own Bluetooth host applications and supports both standard HCI / GXHCI over UART and USB
- Device drivers in HSDK include:
 - Virtual serial port entity
 - NDIS interface module for LAP

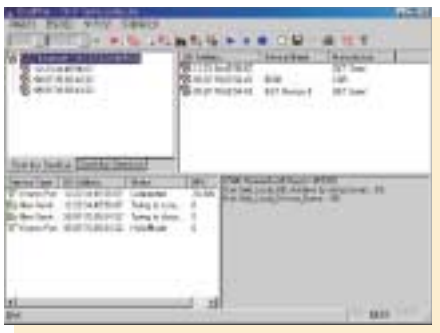

GBLUE-ESDK

- GCT provides embedded stacks and profiles running on various RTOS, such as
 - VOS: GCT proprietary RTOS with smallest memory footprint for Bluetooth
 - GVOS: GCT virtual OS for embedded Bluetooth stack & profile
 - eCos™ by Redhat
- Embedded Stacks and Profiles are optimized for embedded user applications with customized protocols, and further, GCT proprietary software architecture absolutely meets the requisites to implement 'application-embedded' stacks with these major features:

<Application-embedded>

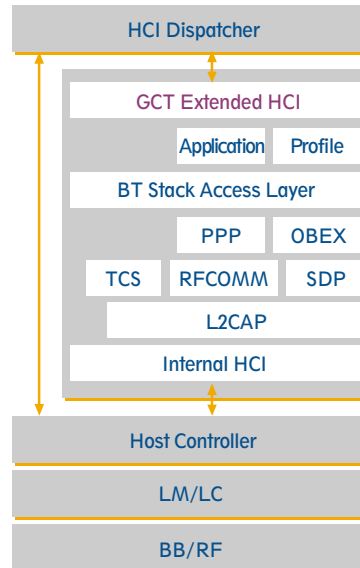

- Support for GXHCI (GCT Extended HCI) with use of approx. 20 abstracted GXHCI commands covering all standard HCI commands
- Multi-threaded emulation on a single thread, which minimizes usage of memory and MIPS





www.gctsemi.com

Head Office

2121 Ringwood Avenue
San Jose, CA 95131
T. 408 434 6040 F. 408 434 6050

GCT Asia Pacific, Inc.

Good Morning Tower 10F, 23-2, Yoido-Dong,
Youngdeungpo-Ku, Seoul 150-712, Korea
T. 82 2 2167 1100 F.82 2 2167 1261

GCT Research, Inc.

Good Morning Tower 15F, 23-2, Yoido-Dong,
Youngdeungpo-Ku, Seoul 150-712, Korea
T. 82 2 2167 1170 F. 82 2 2167 1290

©2001 GCT Semiconductor, Incorporated.

All right reserved. GCT Semiconductor, Inc. is a registered trademark. And other trademarks mentioned in this document are property of their respective owners. Information in this document is preliminary in nature and subject to change without notice.

K-1022-01-PBGDM1000-005