



US008629512B2

(12) **United States Patent**  
**Liaw**

(10) **Patent No.:** **US 8,629,512 B2**  
(45) **Date of Patent:** **Jan. 14, 2014**

(54) **GATE STACK OF FIN FIELD EFFECT TRANSISTOR WITH SLANTED SIDEWALLS**

(75) Inventor: **Jhon Jhy Liaw**, Zhudong Township (TW)

(73) Assignee: **Taiwan Semiconductor Manufacturing Company, Ltd.** (TW)

(\* ) Notice: Subject to any disclaimer, the term of this patent is extended or adjusted under 35 U.S.C. 154(b) by 0 days.

(21) Appl. No.: **13/476,252**

(22) Filed: **May 21, 2012**

(65) **Prior Publication Data**

US 2013/0256764 A1 Oct. 3, 2013

**Related U.S. Application Data**

(60) Provisional application No. 61/616,965, filed on Mar. 28, 2012.

(51) **Int. Cl.**  
**H01L 27/088** (2006.01)

(52) **U.S. Cl.**  
USPC ..... **257/401**; 257/288; 257/368; 257/374; 257/E29.264; 257/E29.137

(58) **Field of Classification Search**  
USPC ..... 257/329, 308, 586; 438/212, 193, 312  
See application file for complete search history.

(56) **References Cited**

**U.S. PATENT DOCUMENTS**

7,355,233 B2 \* 4/2008 Liaw ..... 257/308  
8,084,845 B2 \* 12/2011 Torek et al. .... 257/618  
8,174,073 B2 \* 5/2012 Lee et al. .... 257/347  
8,222,114 B2 \* 7/2012 Chiu et al. .... 438/318

8,394,690 B2 \* 3/2013 Ikeda et al. .... 438/197  
2004/0262699 A1 \* 12/2004 Rios et al. .... 257/401  
2005/0218438 A1 \* 10/2005 Lindert et al. .... 257/296  
2008/0014699 A1 \* 1/2008 Torek et al. .... 438/257  
2008/0277745 A1 \* 11/2008 Hsu et al. .... 257/412  
2008/0296667 A1 \* 12/2008 Mikasa ..... 257/327  
2010/0187575 A1 \* 7/2010 Baumgartner et al. .... 257/255

**FOREIGN PATENT DOCUMENTS**

JP 2008-300384 12/2008  
KR 20050017584 2/2005

**OTHER PUBLICATIONS**

Office Action dated Aug. 21, 2013 from corresponding application No. KR 10-2012-0091127.

\* cited by examiner

*Primary Examiner* — Bilkis Jahan

(74) *Attorney, Agent, or Firm* — Lowe Hauptman & Ham, LLP

(57) **ABSTRACT**

The description relates to a gate stack of a fin field effect transistor (FinFET). An exemplary structure for a FinFET includes a substrate including a first surface and an insulation region covering a portion of the first surface, where a top of the insulation region defines a second surface. The FinFET further includes a fin disposed through an opening in the insulation region to a first height above the second surface, where a base of an upper portion of the fin is broader than a top of the upper portion, wherein the upper portion has first tapered sidewalls and a third surface. The FinFET further includes a gate dielectric covering the first tapered sidewalls and the third surface and a conductive gate strip traversing over the gate dielectric, where the conductive gate strip has second tapered sidewalls along a longitudinal direction of the fin.

**20 Claims, 11 Drawing Sheets**

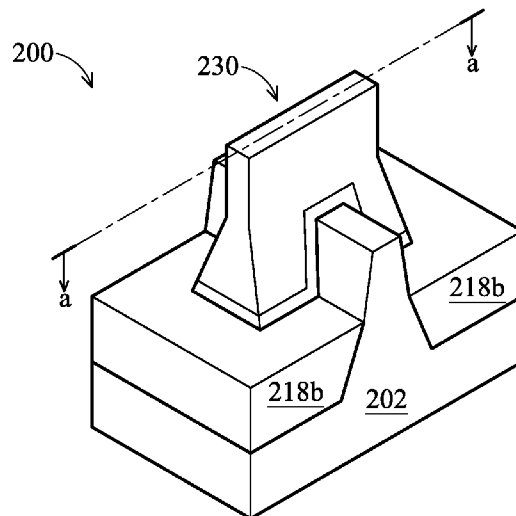

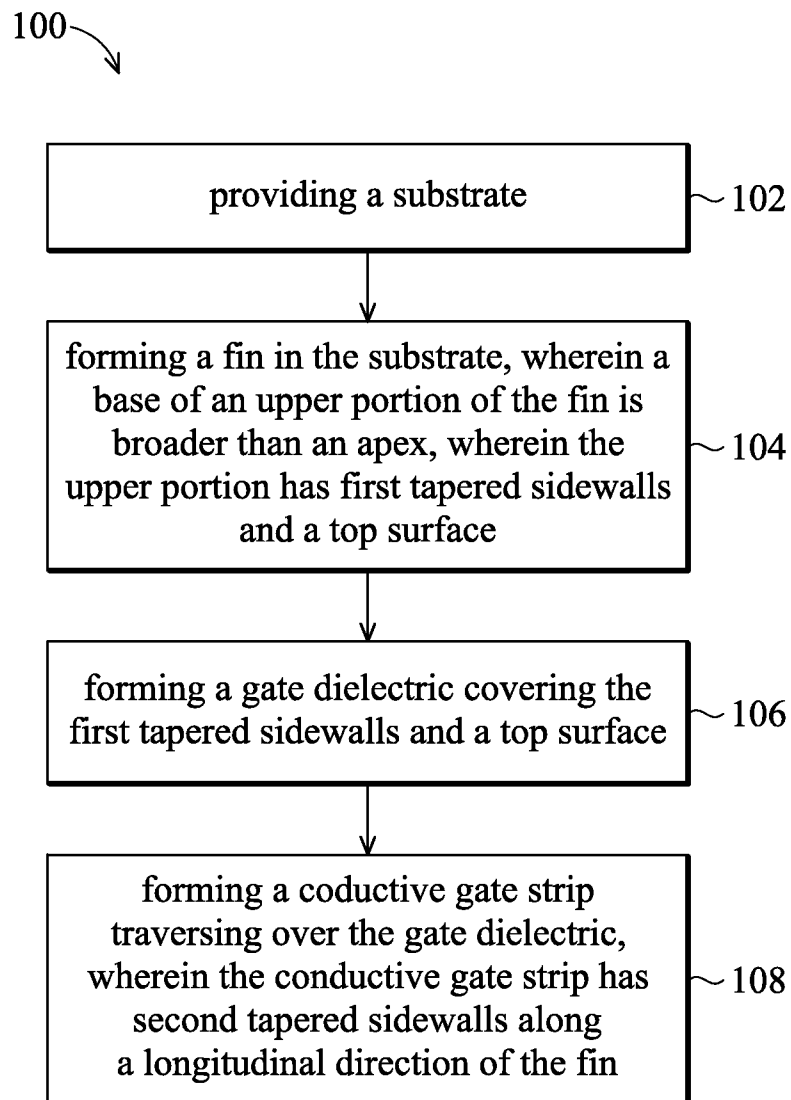

FIG. 1

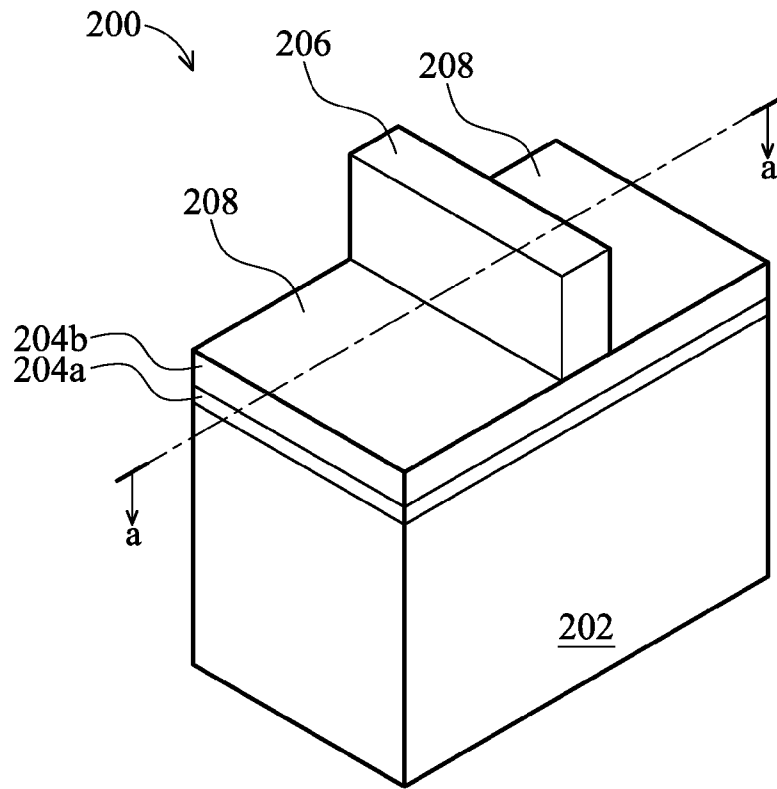

FIG. 2A

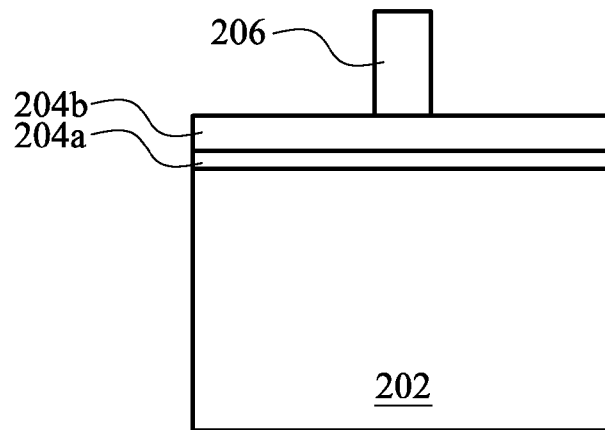

FIG. 2B

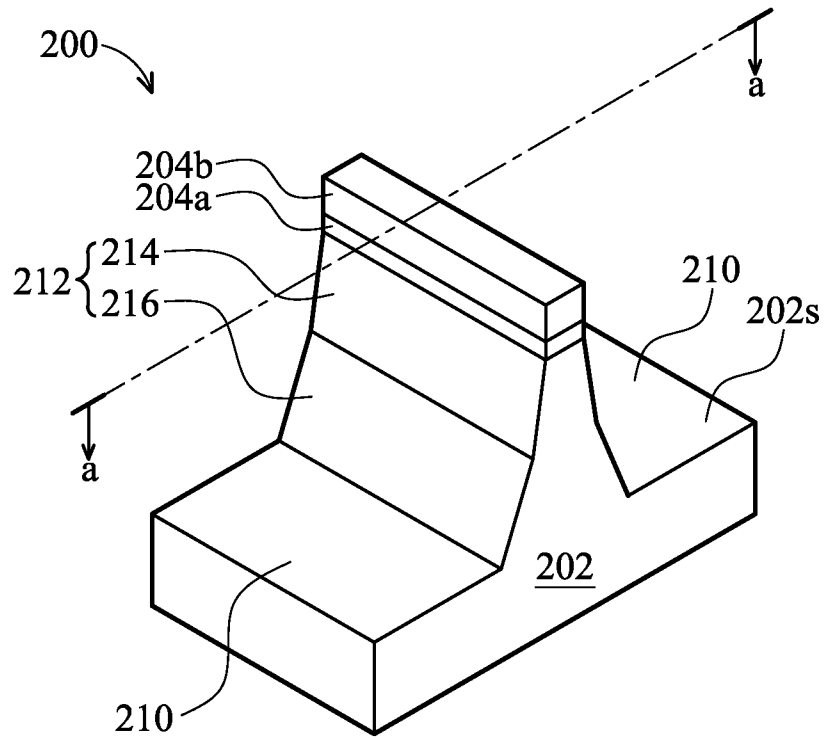

FIG. 3A

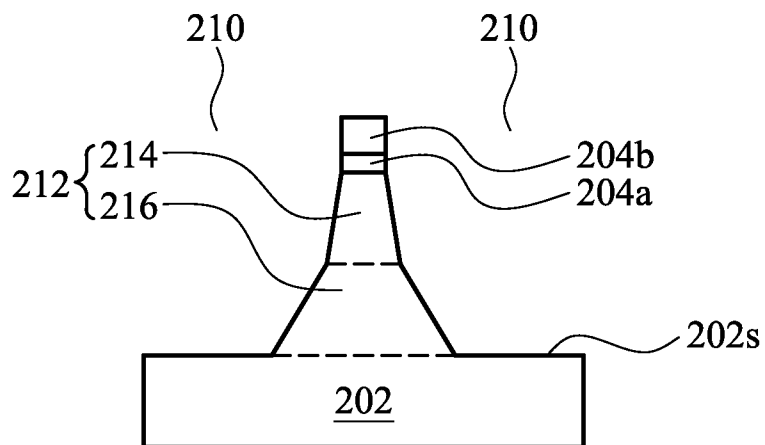

FIG. 3B

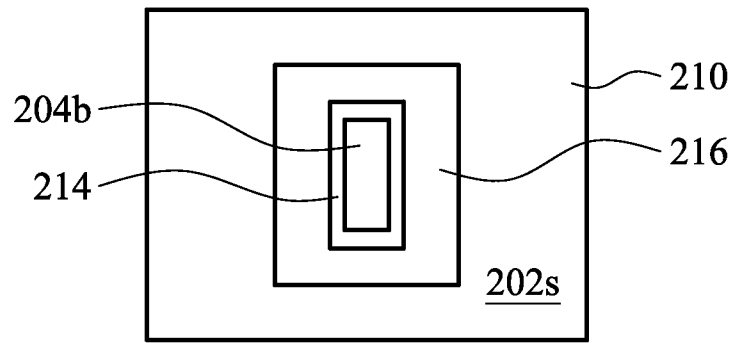

FIG. 3C

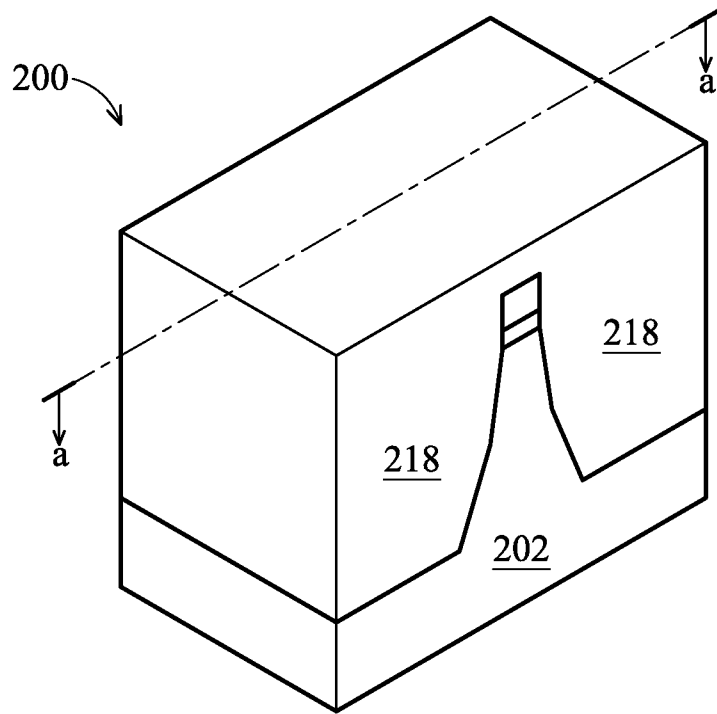

FIG. 4A

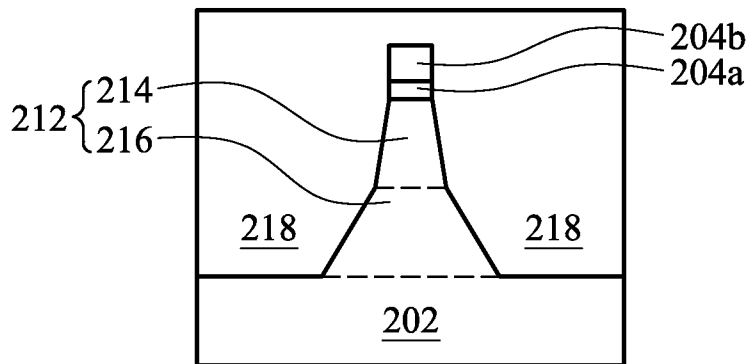

FIG. 4B

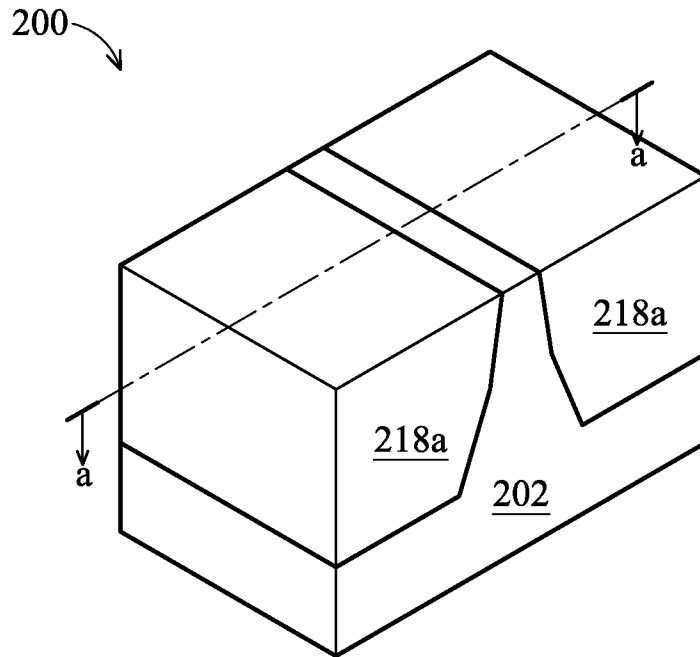

FIG. 5A

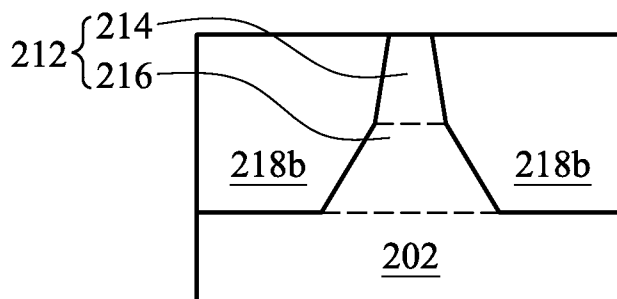

FIG. 5B

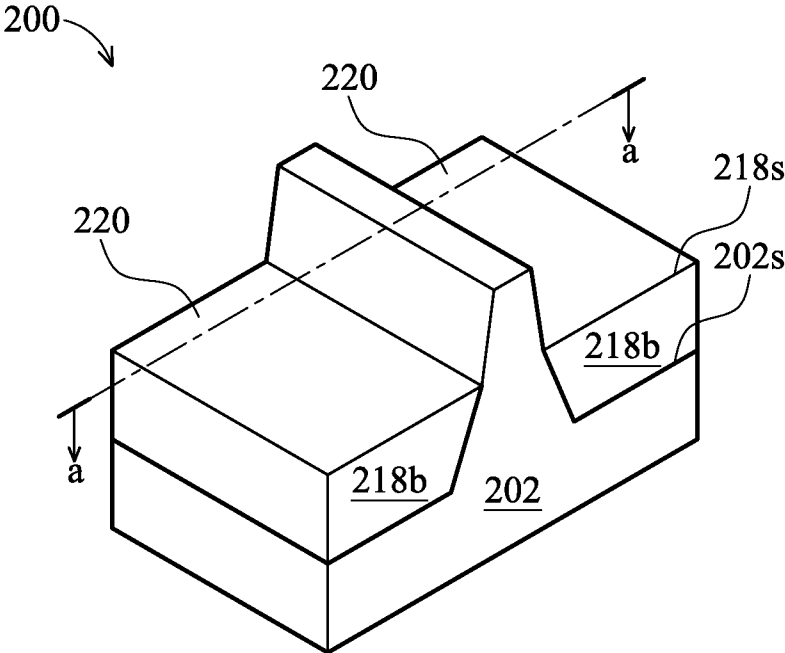

FIG. 6A



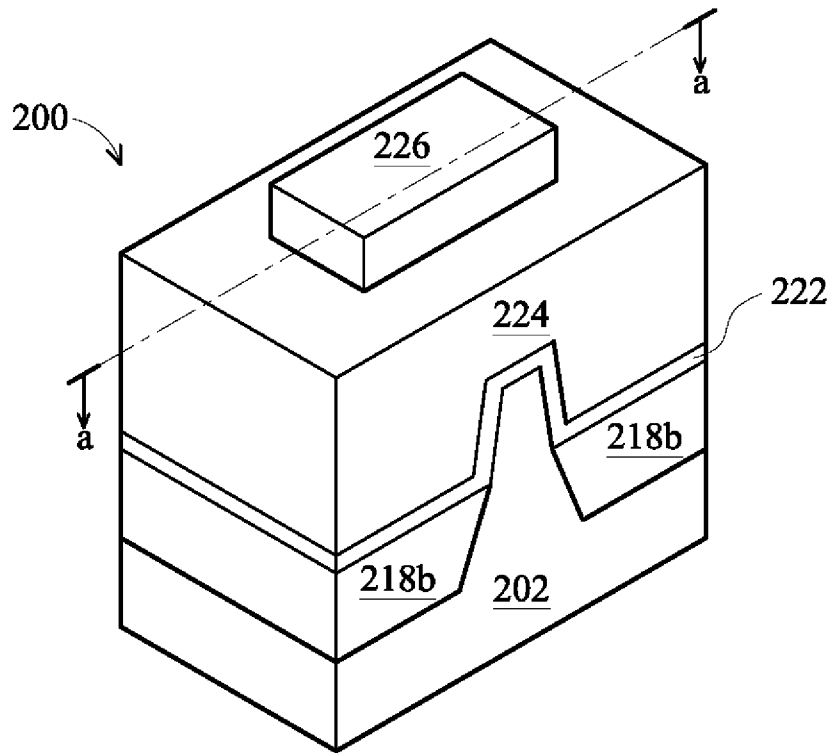

FIG. 7A

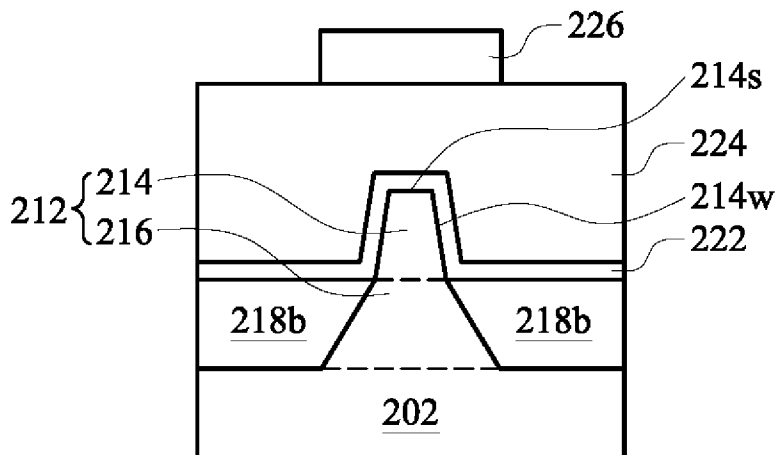

FIG. 7B

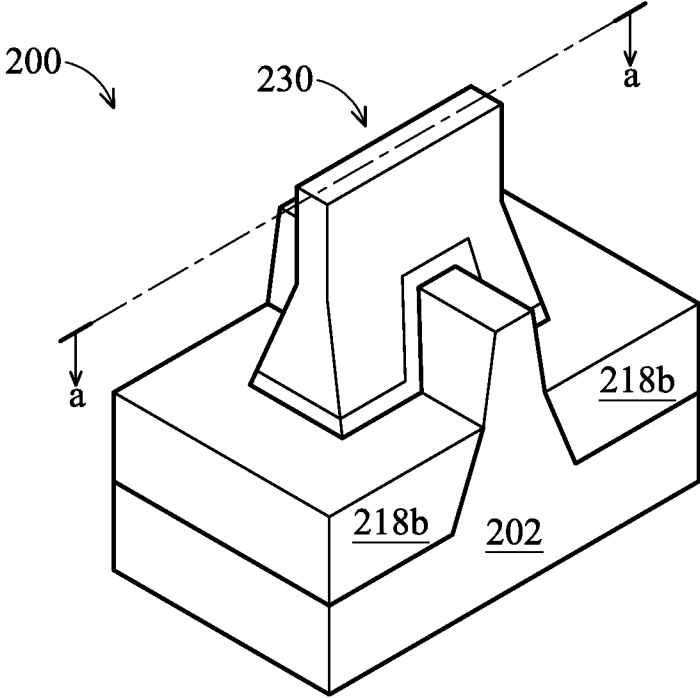

FIG. 8A

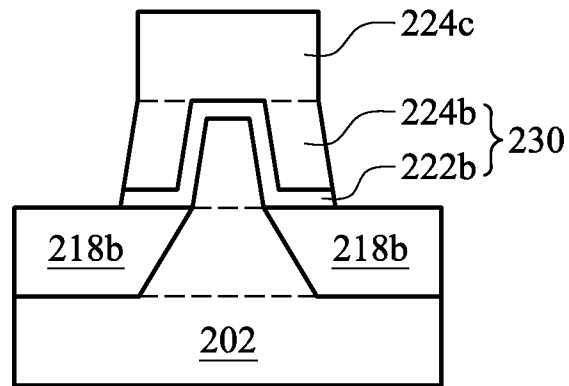

FIG. 8B

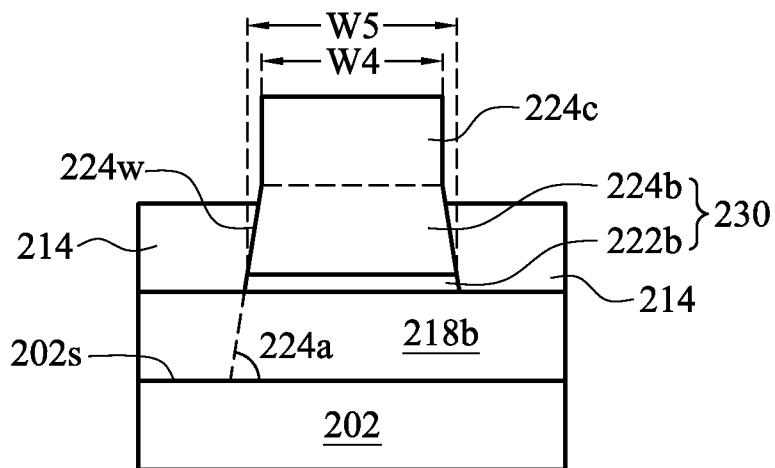

FIG. 8C

## GATE STACK OF FIN FIELD EFFECT TRANSISTOR WITH SLANTED SIDEWALLS

### CROSS-REFERENCE TO RELATED APPLICATIONS

The present application claims priority of U.S. Provisional Patent Application No. 61/616,965, filed on Mar. 28, 2012, which is incorporated herein by reference in its entirety.

### FIELD OF THE INVENTION

The disclosure relates to integrated circuit fabrication, and more particularly to a fin field effect transistor with a gate stack.

### BACKGROUND

As the semiconductor industry has progressed into nanometer technology process nodes in pursuit of higher device density, higher performance, and lower costs, challenges from both fabrication and design issues have resulted in the development of three-dimensional designs, such as a fin field effect transistor (FinFET). A typical FinFET is fabricated with a thin vertical "fin" (or fin structure) extending from a substrate formed by, for example, etching away a portion of a silicon layer of the substrate. The channel of the FinFET is formed in this vertical fin. A gate is provided over (e.g., wrapping) the fin. Having a gate on both sides of the channel allows gate control of the channel from both sides. In addition, strained materials in recessed source/drain (S/D) portions of the FinFET utilizing selectively grown silicon germanium may be used to enhance carrier mobility.

However, there are challenges to implement such features and processes in complementary metal-oxide-semiconductor (CMOS) fabrication. As the spacing between vertical fins decreases, these problems are exacerbated. For example, the FinFET is not fully depleted if gate electrode does not fully wrap the channel of the FinFET, thereby increasing the likelihood of device instability and/or device failure.

### BRIEF DESCRIPTION OF THE DRAWINGS

The present disclosure is best understood from the following detailed description when read with the accompanying figures. It is emphasized that, in accordance with the standard practice in the industry, various features are not drawn to scale and are used for illustration purposes only. In fact, the dimensions of the various features may be arbitrarily increased or reduced for clarity of discussion.

FIG. 1 is a flowchart illustrating a method of fabricating a gate stack of a Fin Field Effect Transistor (FinFET) according to various aspects of the present disclosure; and

FIGS. 2A-8C are perspective, top-down, side, and cross-sectional views of a FinFET comprising a gate stack at various stages of fabrication according to various embodiment of the present disclosure.

### DESCRIPTION

It is understood that the following disclosure provides many different embodiments, or examples, for implementing different features of the invention. Specific examples of components and arrangements are described below to simplify the present disclosure. These are, of course, merely examples and are not intended to be limiting. For example, the formation of a first feature over or on a second feature in the description

that follows may include embodiments in which the first and second features are formed in direct contact, and may also include embodiments in which additional features may be formed between the first and second features, such that the first and second features may not be in direct contact. In addition, the present disclosure may repeat reference numerals and/or letters in the various examples. This repetition is for the purpose of simplicity and clarity and does not in itself dictate a relationship between the various embodiments and/or configurations discussed.

Referring to FIG. 1, illustrated is a flowchart of a method 100 of fabricating a gate stack of a fin field effect transistor (FinFET) according to various aspects of the present disclosure. The method 100 begins with step 102 in which a substrate is provided. The method 100 continues with step 104 in which a fin is formed in the substrate, wherein a base of an upper portion of the fin is broader than an apex of the upper portion, wherein the upper portion has first tapered sidewalls and a top surface. The method 100 continues with step 106 in which a gate dielectric covering the first tapered sidewalls and the top surface is formed. The method 100 continues with step 108 in which a conductive gate strip traversing over the gate dielectric is formed, wherein the conductive gate strip has second tapered sidewalls along a longitudinal direction of the fin. The discussion that follows illustrates embodiments of FinFETs that can be fabricated according to the method 100 of FIG. 1.

FIGS. 2A-8C are perspective, top-down, side, and cross-sectional views of a FinFET 200 comprising a tapered gate stack 230 at various stages of fabrication according to various embodiment of the present disclosure. As employed in the present disclosure, the FinFET 200 refers to any fin-based, multi-gate transistor. The FinFET 200 may be included in a microprocessor, memory cell, and/or other integrated circuit (IC). It is noted that, in some embodiments, the performance of the operations mentioned in FIG. 1 does not produce a completed FinFET 200. A completed FinFET 200 may be fabricated using complementary metal-oxide-semiconductor (CMOS) technology processing. Accordingly, it is understood that additional processes may be provided before, during, and/or after the method 100 of FIG. 1, and that some other processes may only be briefly described herein. Also, FIGS. 2A through 8C are simplified for a better understanding of the concepts of the present disclosure. For example, although the figures illustrate the FinFET 200, it is understood an integrated circuit (IC) may comprise a number of other devices comprising resistors, capacitors, inductors, fuses, etc.

Referring to FIGS. 2A and 2B, and step 102 in FIG. 1, a substrate 202 is provided. FIG. 2A is a perspective view of the FinFET 200 having a substrate 202 at one of the various stages of fabrication according to an embodiment, and FIG. 2B is a cross-sectional view of FinFET 200 taken along the line a-a of FIG. 2A. In at least one embodiment, the substrate 202 comprises a crystalline silicon substrate (e.g., wafer). The substrate 202 may comprise various doped regions depending on design requirements (e.g., p-type substrate or n-type substrate). In some embodiments, the doped regions may be doped with p-type or n-type dopants. For example, the doped regions may be doped with p-type dopants, such as boron or BF<sub>2</sub>; n-type dopants, such as phosphorus or arsenic; and/or combinations thereof. The doped regions may be configured for an n-type FinFET, or alternatively configured for a p-type FinFET.

In some alternative embodiments, the substrate 202 may be made of some other suitable elemental semiconductor, such as diamond or germanium; a suitable compound semiconductor, such as gallium arsenide, silicon carbide, indium ars-

enide, or indium phosphide; or a suitable alloy semiconductor, such as silicon germanium carbide, gallium arsenic phosphide, or gallium indium phosphide. Further, the substrate **202** may include an epitaxial layer (epi-layer), may be strained for performance enhancement, and/or may include a silicon-on-insulator (SOI) structure.

In one embodiment, a pad layer **204a** and a mask layer **204b** are formed on the semiconductor substrate **202**. The pad layer **204a** may be a thin film comprising silicon oxide formed, for example, using a thermal oxidation process. The pad layer **204a** may act as an adhesion layer between the semiconductor substrate **202** and mask layer **204b**. The pad layer **204a** may also act as an etch stop layer for etching the mask layer **204b**. In at least one embodiment, the mask layer **204b** is formed of silicon nitride, for example, using low-pressure chemical vapor deposition (LPCVD) or plasma enhanced chemical vapor deposition (PECVD). The mask layer **204b** is used as a hard mask during subsequent photolithography processes. A photo-sensitive layer **206** is formed on the mask layer **204b** and is then patterned, forming openings **208** in the photo-sensitive layer **206**.

Referring to FIGS. 3A, 3B, and 3C, and step **104** in FIG. 1, after formation of the openings **208** in the photo-sensitive layer **206**, the structure in FIGS. 3A, 3B, and 3C is produced by forming a fin **212** in the substrate **202**, wherein the base **214b** of an upper portion **214** of the fin **212** is broader than the apex **214t**, wherein the upper portion **214** has first tapered sidewalls **214w** and a top surface **214s** (shown in FIGS. 6B and 6C). FIG. 3A is a perspective view of the FinFET **200** at one of the various stages of fabrication according to an embodiment. FIG. 3B is a cross-sectional view of FinFET **200** taken along the line a-a of FIG. 3A and FIG. 3C is a top-down view of FinFET **200** of FIG. 3A.

The mask layer **204b** and pad layer **204a** are etched through openings **208** to expose underlying semiconductor substrate **202**. The exposed semiconductor substrate **202** is then etched to form trenches **210** with a first surface **202s** of the semiconductor substrate **202**. A portion of the semiconductor substrate **202** between trenches **210** forms one semiconductor fin **212**. In the depicted embodiment, the semiconductor fin **212** comprises an upper portion **214** and a lower portion **216** (separated by the dashed line). In the present embodiment, the upper portion **214** and the lower portion **216** comprise the same material, such as silicon.

Trenches **210** may be strips (viewed from in the top of the FinFET **200**) parallel to each other, and closely spaced with respect to each other. Trenches **210** each have a width, a depth, and are spaced apart from adjacent trenches by a spacing *S*. For example, the spacing *S* between trenches **210** may be smaller than about 30 nm. In an alternative embodiment, trenches **210** may be continuous and surrounding the semiconductor fin **212** (shown in FIG. 3C). The photo-sensitive layer **206** is then removed. Next, a cleaning may be performed to remove a native oxide of the semiconductor substrate **202**. The cleaning may be performed using diluted hydrofluoric (DHF) acid.

Liner oxide (not shown) is then optionally formed in the trenches **210**. In an embodiment, liner oxide may be a thermal oxide having a thickness ranging from about 20 Å to about 500 Å. In some embodiments, liner oxide may be formed using in-situ steam generation (ISSG) and the like. The formation of liner oxide rounds corners of the trenches **210**, which reduces the electrical fields, and hence improves the performance of the resulting integrated circuit.

FIG. 4A is a perspective view of the FinFET **200** at one of the various stages of fabrication according to an embodiment, and FIG. 4B is a cross-sectional view of FinFET **200**

along the line a-a of FIG. 4A. Trenches **210** are filled with a dielectric material **218**. The dielectric material **218** may include silicon oxide, and hence is also referred to as oxide **218** in the present disclosure. In some embodiments, other dielectric materials, such as silicon nitride, silicon oxynitride, fluoride-doped silicate glass (FSG), or a low-K dielectric material, may also be used. In an embodiment, the oxide **218** may be formed using a high-density-plasma (HDP) CVD process, using silane (SiH<sub>4</sub>) and oxygen (O<sub>2</sub>) as reacting precursors. In other embodiments, the oxide **218** may be formed using a sub-atmospheric CVD (SACVD) process or high aspect-ratio process (HARP), wherein process gases may comprise tetraethylorthosilicate (TEOS) and/or ozone (O<sub>3</sub>). In yet other embodiment, the oxide **218** may be formed using a spin-on-dielectric (SOD) process, such as hydrogen silsesquioxane (HSQ) or methyl silsesquioxane (MSQ).

FIGS. 4A and 4B depict the resulting structure after the deposition of the dielectric material **218**. A chemical mechanical polish is then performed, followed by the removal of the mask layer **204b** and pad layer **204a**. The resulting structure is shown in FIGS. 5A and 5B. FIG. 5A is a perspective view of the FinFET **200** at one of the various stages of fabrication according to an embodiment, and FIG. 5B is a cross-sectional view of FinFET **200** taken along the line a-a of FIG. 5A.

The remaining portions of the oxide **218** in the trenches **210** are hereinafter referred to as insulation regions **218a**. In double-gate embodiments, the mask layer **204b** and pad layer **204a** remain on the top of the fin **212** (not shown). In triple-gate embodiments, the mask layer **204b** is formed of silicon nitride, the mask layer **204b** may be removed using a wet process using hot H<sub>3</sub>PO<sub>4</sub>, while the pad layer **204a** may be removed using diluted HF acid, if formed of silicon oxide. The mask layer and pad layer remaining on top of the fin may prevent the top of the fin from turn-on to form a double-gate FinFET. In some alternative embodiments, the removal of the mask layer **204b** and pad layer **204a** may be performed after the recessing of the insulation regions **218a**, which recessing step is shown in FIGS. 6A, 6B, and 6C.

In an alternative embodiment, the upper portion **214** of the fin **212** is replaced by another semiconductor material to enhance device performance. Using insulation regions **218a** as a hard mask, the upper portion **214** of the fin **212** is recessed by an etching step. Then a different material such as Ge is epi-grown to fill the recessed portion. In the depicted embodiment, the upper portion **214** of the fin **212** such as Ge and lower portion **216** of the fin **212** such as Si comprise different materials.

As shown in FIGS. 6A, 6B, and 6C, after the removal of the mask layer **204b** and pad layer **204a**, the insulation regions **218a** are recessed by an etching step, resulting in recesses **220**. FIG. 6A is a perspective view of the FinFET **200** at one of the various stages of fabrication according to an embodiment. FIG. 6B is a cross-sectional view of FinFET **200** taken along the line a-a of FIG. 6A and FIG. 6C is a top-down view of FinFET **200** of FIG. 6A. In one embodiment, the etching step may be performed using a wet etching process, for example, by dipping the substrate **202** in hydrofluoric acid (HF). In another embodiment, the etching step may be performed using a dry etching process, for example, the dry etching process may be performed using CHF<sub>3</sub> or BF<sub>3</sub> as etching gases.

The remaining insulation regions **218b** may be strips (viewed from in the top of the FinFET **200**) parallel to each other, and closely spaced with respect to each other. In an alternative embodiment, the remaining insulation regions **218b** may be continuous and surrounding the semiconductor

fin **212** (shown in FIG. 6C). FIG. 6C is top-down view of FinFET **200** of FIG. 6A and further comprises remaining insulation regions **218b** not shown in FIG. 6A. Further, the insulation regions **218b** cover a portion of the first surface **202s**, wherein a top of the insulation region defines a second surface **218s**.

In the depicted embodiment, the fin **212** through an opening in the insulation region **218b** to a first height  $H_1$  above the second surface **218s**, wherein the base **214b** of an upper portion **214** (shown by the dashed line) of the fin **212** is broader than the apex **214t**, wherein the upper portion **214** has first tapered sidewalls **214w** and top surface **214s** (or defined as a third surface **214s**). In one embodiment, the base **214b** may be coplanar with the second surface **218s**, although the base **214b** may also be higher or lower than the second surface **218s**. The upper portion **214** of the fin **212** thus is used to form a channel region of the FinFET **200**.

In at least one embodiment, an angle **214a** of the first tapered sidewalls **214w** to the first surface **202s** is from about 84 degrees to 88 degrees. In some embodiments, a difference between a maximum width  $W_2$  of the first tapered sidewalls **214w** and a width  $W_1$  of the third surface **214s** is in the range of about 1.5 nm to 5 nm. In some embodiments, a first height  $H_1$  of upper portion **214** above the second surface **218s** is in the range of about 20 to 50 nm.

In some embodiments, the semiconductor fin **212** further comprises a lower portion **216** extending downward from the base **214b** to the first surface **202s** has a second height  $H_2$ . The lower portion **216** has third tapered sidewalls **216w**. In at least one embodiment, an angle **216a** of the third tapered sidewalls **216w** to the first surface **202s** is from about 60 degrees to 85 degrees. In some embodiments, a difference between a maximum width  $W_3$  of the third tapered sidewalls **216w** and the maximum width  $W_2$  of the first tapered sidewalls **214w** is in the range of about 3 nm to 10 nm. In yet another embodiment, a ratio of the first height  $H_1$  to the second height  $H_2$  is from about 0.2 to 0.5. Having more rigid volume than the upper portion **214**, the lower portion **216** can avoid fin **212** deformation of the FinFET **200** due to high stress in the insulation regions **218b**.

A tapered gate stack **230** is then formed over the substrate **202** over the first tapered sidewalls **214w** and the third surface **214s** of the upper portion **214** and extending across the second surface **218s** of the insulation region **218b**. In some embodiments, the tapered gate stack **230** comprises a gate dielectric **222b** and a gate electrode layer **224b** over the gate dielectric layer **222b** (shown in FIGS. 8A, 8B, and 8C).

As depicted in FIGS. 7A and 7B, and step **106** in FIG. 1, for fabricating a gate stack (such as a tapered gate stack **230** shown in FIGS. 8A, 8B, and 8C), the structure in FIGS. 7A and 7B are produced by forming a gate dielectric **222** to cover the first tapered sidewalls **214w** and the third surface **214s** of the upper portion **214** and extending across the second surface **218s** of the insulation region **218b**. FIG. 7A is a perspective view of the FinFET **200** at one of the various stages of fabrication according to an embodiment, and FIG. 7B is a cross-sectional view of FinFET **200** taken along the line a-a of FIG. 7A.

In some embodiments, the gate dielectric **222** may include silicon oxide, silicon nitride, silicon oxy-nitride, or high-k dielectrics. High-k dielectrics comprise metal oxides. Examples of metal oxides used for high-k dielectrics include oxides of Li, Be, Mg, Ca, Sr, Sc, Y, Zr, Hf, Al, La, Ce, Pr, Nd, Sm, Eu, Gd, Tb, Dy, Ho, Er, Tm, Yb, Lu and/or mixtures thereof. In the depicted embodiment, the gate dielectric **222** is a high-k dielectric layer with a thickness in the range of about 10 angstroms to 30 angstroms. The gate dielectric **222** may be

formed using a suitable process such as atomic layer deposition (ALD), chemical vapor deposition (CVD), physical vapor deposition (PVD), thermal oxidation, UV-ozone oxidation, or combinations thereof. The gate dielectric **222** may further comprise an interfacial layer (not shown) to reduce damage between the gate dielectric **222** and upper portion **214** of the fin **212** (i.e., channel region of the FinFET **200**). The interfacial layer may comprise silicon oxide.

Then, as depicted in FIGS. 7A and 7B, and step **108** in FIG. 1, the gate electrode layer **224** is formed over the gate dielectric **222**. In the present embodiment, the gate electrode layer **224** covering the upper portion **214** of the semiconductor fin **212** is used to form a separate FinFET **200**. In an alternative embodiment, the gate electrode layer **224** covers the upper portion **214** of more than one semiconductor fin **212** (not shown), so that the resulting FinFET comprises more than one fin.

In some embodiments, the gate electrode layer **224** may comprise a single-layer or multilayer structure. In at least one embodiment, the gate electrode layer **224** comprises polysilicon. Further, the gate electrode layer **224** may be doped polysilicon with uniform or non-uniform doping. In some embodiments, the gate electrode layer **224** comprises a metal selected from a group of W, Cu, Ti, Ag, Al, TiAl, TiAlN, TaC, TaCN, TaSiN, Mn, and Zr. In some embodiments, the gate electrode layer **224** comprises a metal selected from a group of TiN, WN, TaN, and Ru. In the depicted embodiment, the gate electrode layer **224** comprises a thickness in the range of about 30 nm to about 60 nm. The gate electrode layer **224** may be formed using a suitable process such as ALD, CVD, PVD, plating, or combinations thereof.

The process steps up to this point have provided the substrate **202** having the gate dielectric **222** covering the first tapered sidewalls **214w** and third surface **214s** of the upper portion **214**, and the gate electrode layer **224** formed over the gate dielectric **222**. In some embodiments, a layer of photoresist is formed over the gate electrode layer **224** by a suitable process, such as spin-on coating, and patterned to form a patterned photoresist feature **226** over the gate electrode layer **224** by a proper lithography patterning method. The patterned photoresist feature **226** can then be transferred using a dry etching process to the underlying layers (i.e., the gate dielectric **222** and gate electrode layer **224**) to form a gate stack along the longitudinal direction of the fin **212**. The patterned gate electrode layer is referred to a conductive gate strip. The conductive gate strip thus wraps a channel portion of the exposed upper portion **214** of the fin **212**.

However, the conductive gate strip along the longitudinal direction of the fin **212** (with the first tapered sidewalls **214w**) is perpendicular to the first surface **202s**. As such, the first tapered sidewalls **214w** with a wider bottom are not fully wrapped by the conductive gate strip, resulting in a non-fully depleted fin when the FinFET is in on-state. This decreases drain-induced-barrier-lowering (DIBL) and increases sub-threshold leakage on a lower portion of the first tapered sidewalls **214w**, thereby degrading the device performance.

Accordingly, the processing discussed below with reference to FIGS. 8A, 8B, and 8C may etch the gate dielectric **222** and gate electrode layer **224** to form a tapered gate stack along the longitudinal direction of the fin **212** to fully wrap the wider bottom of the first tapered sidewalls **214w**. This can help to form a fully depleted fin when the FinFET is in on-state, thereby improving DIBL and sub-threshold leakage of the FinFET **200** and thus upgrading device performance.

As depicted in FIGS. 8A, 8B, and 8C, and step **108** in FIG. 1, for fabricating a tapered gate stack **230**, the structure in FIGS. 8A, 8B, and 8C Figs. are produced by forming a con-

ductive gate strip **224b** traversing over the gate dielectric **222b**, wherein the conductive gate strip **224a** has second tapered sidewalls **224w** along the longitudinal direction of the fin **212**. FIG. **8A** is a perspective view of the FinFET **200** at one of the various stages of fabrication according to an embodiment. FIG. **8B** is a cross-sectional view of FinFET **200** taken along the line a-a of FIG. **8A** and FIG. **8C** is a side view of FinFET **200** along a plane perpendicular to the line a-a of FIG. **8A**.

As depicted in FIGS. **8A**, **8B** and **8C**, the patterned photoresist feature **226** can then be transferred using a dry etching process to the underlying layers (i.e., the gate dielectric **222** and gate electrode layer **224**) to form the tapered gate stack **230** along longitudinal direction of the fin **212**. In at least one embodiment, in which the gate electrode layer **224** is polysilicon, the step of the dry etch process is performed under a source power of about 650 to 800 W, a bias power of about 100 to 120 W, and a pressure of about 60 to 200 mTorr, using  $\text{Cl}_2$ , HBr and He as etching gases. The patterned photoresist feature **226** may be stripped thereafter.

In the depicted embodiment, a remaining gate dielectric **222b** covers the first tapered sidewalls **214w** and the third surface **214s**, while a remaining gate electrode layer **224b** (or referred as a conductive gate strip **224b**) traverses over the remaining gate dielectric **222b**, wherein the conductive gate strip **224b** has second tapered sidewalls **224w** along the longitudinal direction of the fin **212**. In at least one embodiment, an angle **224a** of the second tapered sidewalls **224w** to the first surface **202s** is from about 85 degree to 88 degree. In some embodiments, a ratio of a maximum width  $W_5$  of the second tapered sidewalls **224w** to a minimum width  $W_4$  of the second tapered sidewalls **224w** is from 1.05 to 1.25. In some embodiments, the conductive gate strip **224b** further comprises a substantially vertical portion **224c** over the second tapered sidewalls **224w**.

In the depicted embodiment, the remaining gate dielectric **222b** and conductive gate strip **224b** are combined and referred as the tapered gate stack **230**. The tapered gate stack **230** may wrap the wider bottom of the first tapered sidewalls **214w**. Thus, method **100** can help to form a fully depleted fin when the FinFET is in on-state, thereby improving DIBL and sub-threshold leakage of the FinFET **200** and thus upgrading device performance.

In the depicted embodiment, the tapered gate stack **230** is fabricated using a gate-first process. In an alternative embodiment, the tapered gate stack **230** may be fabricated using a gate-last process. In one embodiment, the gate-last process comprises forming an inter-layer dielectric (ILD) surrounding the dummy tapered gate stack **230**, removing a dummy conductive gate strip to form a trench in the ILD, then fill the trench with a conductive gate strip. In some embodiments, the gate-last process comprises forming an ILD surrounding a dummy tapered gate stack, removing the dummy conductive gate strip **224b** and a dummy gate dielectric to form a trench in the ILD, then fill the trench with a gate dielectric and a conductive gate strip.

It is understood that the FinFET **200** may undergo further CMOS processes to form various features such as source/drain regions, contacts/vias, interconnect metal layers, dielectric layers, passivation layers, etc. It has been observed that a modified gate stack may wrap the wider bottom of the first tapered sidewalls **214w** to form a fully depleted fin when the FinFET is in on-state, thereby improving DIBL and sub-threshold leakage of the FinFET **200** and thus upgrading device performance.

In accordance with embodiments, a Fin field effect transistor (FinFET) comprises a substrate comprising a first surface;

an insulation region covering a portion of the first surface, wherein a top of the insulation region defines a second surface; a fin disposed through an opening in the insulation region to a first height above the second surface, wherein a base of an upper portion of the fin is broader than a top of the upper portion, wherein the upper portion has first tapered sidewalls and a third surface; a gate dielectric covering the first tapered sidewalls and the third surface; and a conductive gate strip traversing over the gate dielectric, wherein the conductive gate strip has second tapered sidewalls along a longitudinal direction of the fin.

In accordance with other embodiments, a Fin field effect transistor (FinFET) comprises a substrate comprising a first surface; an insulation region covering a portion of the first surface, wherein a top of the insulation region defines a second surface; a fin disposed through an opening in the insulation region to a first height above the second surface, wherein a base of an upper portion of the fin is broader than a top of the upper portion, wherein the upper portion has first tapered sidewalls and a third surface, wherein the fin further comprises a lower portion extending downward from the base of the upper portion to the first surface and having a second height, wherein the lower portion has second tapered sidewalls; a gate dielectric covering the first tapered sidewalls and the third surface; and a conductive gate strip traversing over the gate dielectric, wherein the conductive gate strip has third tapered sidewalls along a longitudinal direction of the fin.

In accordance with yet other embodiments, a Fin field effect transistor (FinFET) comprises a substrate comprising a first surface; an insulation region covering a portion of the first surface, wherein a top of the insulation region defines a second surface; a fin disposed through an opening in the insulation region to a first height above the second surface, wherein a base of an upper portion of the fin is broader than a top of the upper portion, wherein the upper portion has first tapered sidewalls and a third surface; a gate dielectric covering the first tapered sidewalls and the third surface; and a conductive gate strip traversing over the gate dielectric, wherein the conductive gate strip has second tapered sidewalls along a longitudinal direction of the fin, wherein the conductive gate strip further comprises a substantially vertical portion over the second tapered sidewalls.

While the invention has been described by way of example and in terms of the preferred embodiments, it is to be understood that the invention is not limited to the disclosed embodiments. To the contrary, it is intended to cover various modifications and similar arrangements (as would be apparent to those skilled in the art). Therefore, the scope of the appended claims should be accorded the broadest interpretation so as to encompass all such modifications and similar arrangements.

What is claimed is:

1. A Fin field effect transistor (FinFET) comprising:

- a substrate comprising a first surface;
- an insulation region covering a portion of the first surface, wherein a top of the insulation region defines a second surface;
- a fin disposed through an opening in the insulation region to a first height above the second surface, wherein a base of an upper portion of the fin is broader than a top of the upper portion, wherein the upper portion has first tapered sidewalls and a third surface;
- a gate dielectric covering the first tapered sidewalls and the third surface; and
- a conductive gate strip traversing over the gate dielectric, wherein the conductive gate strip has second tapered sidewalls along a longitudinal direction of the fin perpendicular to the first height, and the conductive gate

9

strip is broader in the longitudinal direction of the fin at a base of the second tapered sidewalls than at a top of the second tapered sidewalls.

2. The FinFET of claim 1, wherein the first height is in the range of about 20 nm to 50 nm.

3. The FinFET of claim 1, wherein the fin comprises at least one of Si, Ge, a compound semiconductor or an alloy semiconductor.

4. The FinFET of claim 1, wherein an angle of the second tapered sidewalls to the first surface is from about 85 degree to 88 degree.

5. The FinFET of claim 1, wherein a ratio of a maximum width of the second tapered sidewalls to a minimum width of the second tapered sidewalls is from 1.05 to 1.25.

6. The FinFET of claim 1, wherein the conductive gate strip comprises poly-silicon.

7. The FinFET of claim 1, wherein the conductive gate strip comprises at least one metal selected from a group of W, Cu, Ti, Ag, Al, TiAl, TiAlN, TaC, TaCN, TaSiN, Mn, or Zr.

8. The FinFET of claim 1, wherein the conductive gate strip comprises at least one metal selected from a group of TiN, WN, TaN, or Ru.

9. The FinFET of claim 1, wherein the conductive gate strip further comprises a substantially vertical portion over the second tapered sidewalls.

10. The FinFET of claim 1, wherein the gate dielectric comprises at least one of silicon oxide, silicon nitride, or silicon oxy-nitride.

10

11. The FinFET of claim 1, wherein the gate dielectric comprises a high-k dielectric.

12. The FinFET of claim 1, further comprises an interfacial layer between the third surface and the gate dielectric.

13. The FinFET of claim 12, wherein the interfacial layer comprises silicon oxide.

14. The FinFET of claim 1, wherein an angle of the first tapered sidewalls to the first surface is from about 84 degrees to 88 degrees.

15. The FinFET of claim 14, wherein a difference between a maximum width of the first tapered sidewalls and a width of the third surface is in the range of about 1.5 nm to 5 nm.

16. The FinFET of claim 1, wherein the fin further comprises a lower portion extending downward from the base of the upper portion to the first surface and having a second height, wherein the lower portion has third tapered sidewalls.

17. The FinFET of claim 16, wherein an angle of the third tapered sidewalls to the first surface is from about 60 degrees to 85 degrees.

18. The FinFET of claim 16, wherein a ratio of the first height to the second height is from about 0.2 to 0.5.

19. The FinFET of claim 16, wherein the upper portion and the lower portion comprise the same material.

20. The FinFET of claim 16, wherein the upper portion and the lower portion comprise different materials.

\* \* \* \* \*