



US007172943B2

(12) **United States Patent**
Yeo et al.

(10) **Patent No.:** **US 7,172,943 B2**
(45) **Date of Patent:** **Feb. 6, 2007**

(54) **MULTIPLE-GATE TRANSISTORS FORMED ON BULK SUBSTRATES**

(75) Inventors: **Yee-Chia Yeo**, Hsin-Chu (TW);
Fu-Liang Yang, Hsin-Chu (TW);
Chenming Hu, Hsin-Chu (TW)

(73) Assignee: **Taiwan Semiconductor Manufacturing Company, Ltd.**,
Hsin-Chu (TW)

(*) Notice: Subject to any disclaimer, the term of this patent is extended or adjusted under 35 U.S.C. 154(b) by 0 days.

6,252,284 B1	6/2001	Muller et al.	
6,342,410 B1 *	1/2002	Yu	438/164
6,391,695 B1	5/2002	Yu	
6,391,782 B1	5/2002	Yu	
6,413,802 B1	7/2002	Hu et al.	
6,432,829 B2 *	8/2002	Muller et al.	438/694
6,451,656 B1	9/2002	Yu et al.	
6,475,890 B1 *	11/2002	Yu	438/574
6,492,212 B1	12/2002	Jeong et al.	
6,525,403 B2 *	2/2003	Inaba et al.	257/618
6,635,909 B2 *	10/2003	Clark et al.	257/192
6,720,619 B1 *	4/2004	Chen et al.	257/347
6,764,884 B1 *	7/2004	Yu et al.	438/157

(21) Appl. No.: **10/669,395**

(22) Filed: **Sep. 24, 2003**

(65) **Prior Publication Data**

US 2005/0035415 A1 Feb. 17, 2005

Related U.S. Application Data

(60) Provisional application No. 60/495,071, filed on Aug. 13, 2003.

(51) **Int. Cl.**

H01L 21/336 (2006.01)

H01L 21/00 (2006.01)

H01L 29/76 (2006.01)

(52) **U.S. Cl.** **438/300**; 438/157; 438/283; 257/329; 257/331

(58) **Field of Classification Search** 438/157, 438/283, 300; 257/329, 330, 331, 157
See application file for complete search history.

(56) **References Cited**

U.S. PATENT DOCUMENTS

5,893,741 A * 4/1999 Huang 438/300

OTHER PUBLICATIONS

Huang, X., et al. "Sub-50 nm P-Channel FinFET," IEEE Transactions on Electron Devices, vol. 48, No. 5 (May 2001) pp. 880-886.
Yang, F.L., et al. "35nm CMOS FinFETs," 2002 Symposium on VLSI Technology Digest of Technical Papers, (Jun. 2002) pp. 109-110.

(Continued)

Primary Examiner—Douglas W. Owens

Assistant Examiner—Samuel A Gebremariam

(74) *Attorney, Agent, or Firm*—Slater & Matsil, L.L.P.

(57) **ABSTRACT**

In one aspect, the present invention teaches a multiple-gate transistor **130** that includes a semiconductor fin **134** formed in a portion of a bulk semiconductor substrate **132**. A gate dielectric **144** overlies a portion of the semiconductor fin **134** and a gate electrode **146** overlies the gate dielectric **144**. A source region **138** and a drain region **140** are formed in the semiconductor fin **134** oppositely adjacent the gate electrode **144**. In the preferred embodiment, the bottom surface **150** of the gate electrode **146** is lower than either the source-substrate junction **154** or the drain-substrate junction **152**.

36 Claims, 6 Drawing Sheets

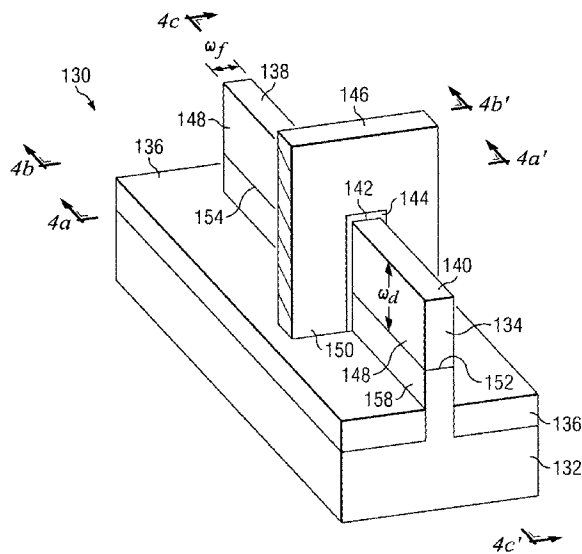

OTHER PUBLICATIONS

Wong, H.-S.P. "Beyond the Conventional Transistor," IBM Journal of Research and Development (Mar./May 2002) pp. 133-167.

Chau, R., et al. "Advanced Depleted-Substrate Transistors: Single-gate, Double-gate and Tri-gate," Extended Abstracts of the 2002 International Conference on Solid State Devices and Materials, (2002) pp. 68-69.

Yang, F.L., et al. "25nm CMOS Omega FETs," International Electron Devices Meeting, Digest of Technical Papers, (Dec. 2002) pp. 255-258.

Colinge, J.P., et al. "Silicon-on-Insulator "Gate -All-Around Device"," International Electron Devices Meeting, (1990) pp. 595-598.

Leobandung, E. "Wire-Channel and wrap-around-gate metal-oxide-semiconductor field-effect transistors with a significant reduction of short channel effects," Journal of Vacuum Science and Technology, vol. B15, No. 6, (Nov./Dec. 1997) pp. 2791-2794.

* cited by examiner

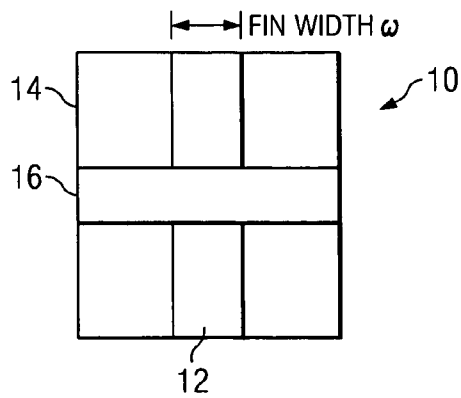

FIG. 1
(PRIOR ART)

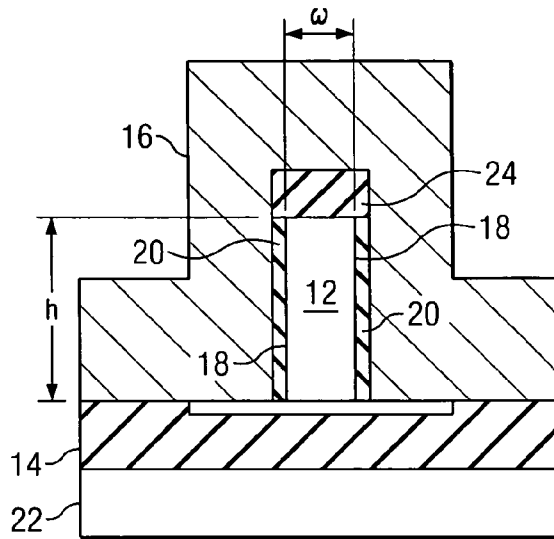

FIG. 2a
(PRIOR ART)

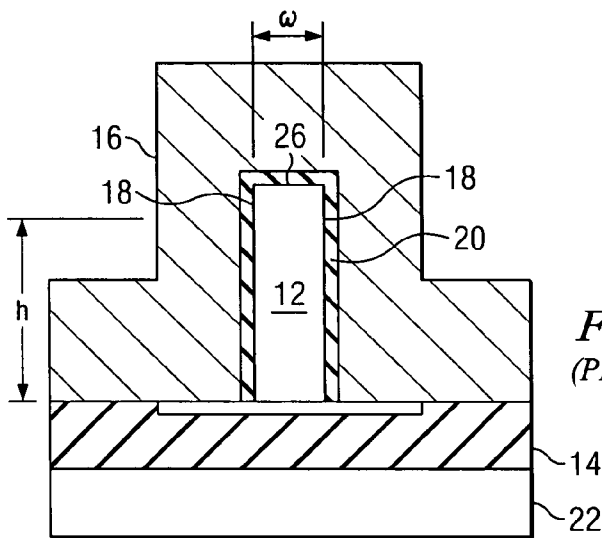

FIG. 2b
(PRIOR ART)

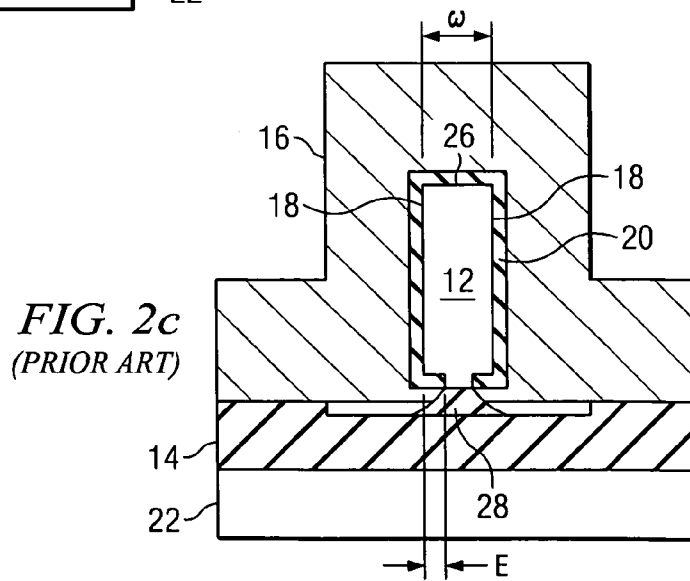
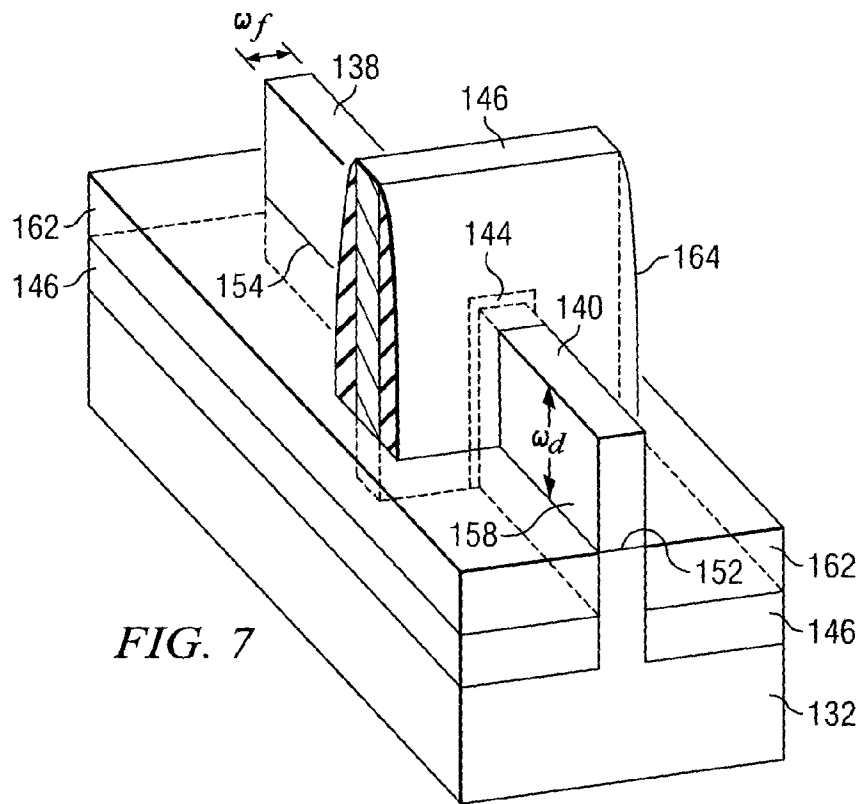
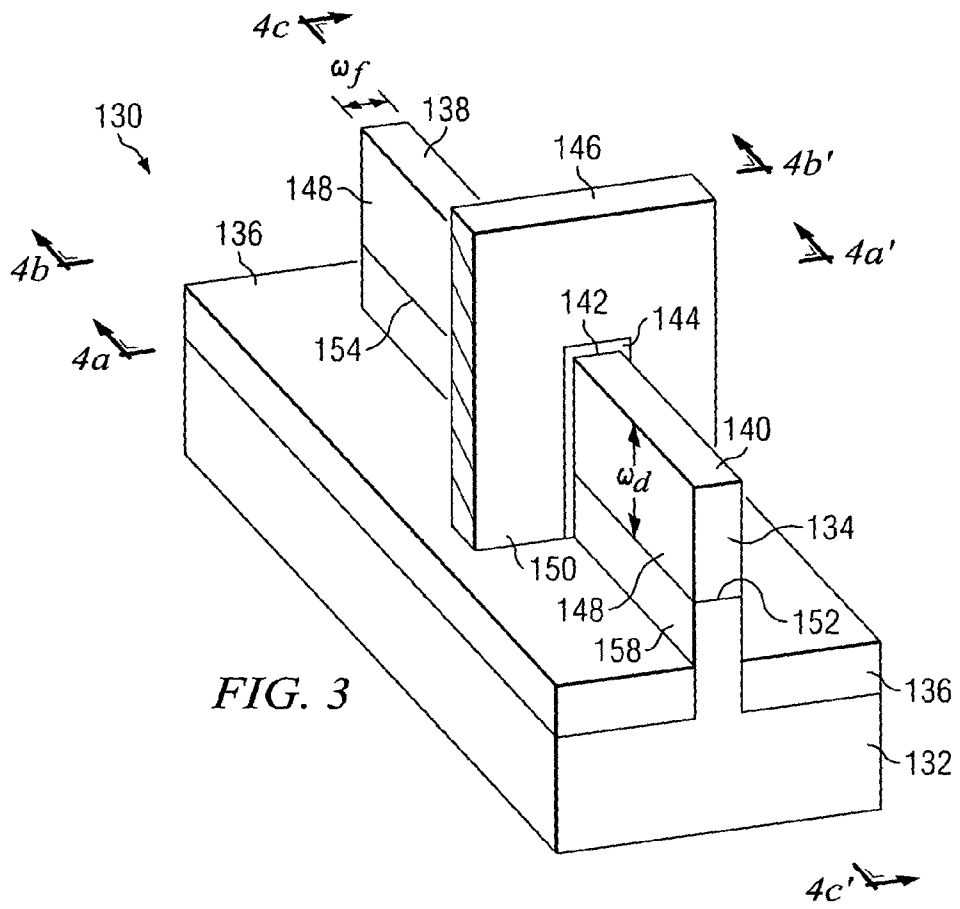

FIG. 2c
(PRIOR ART)



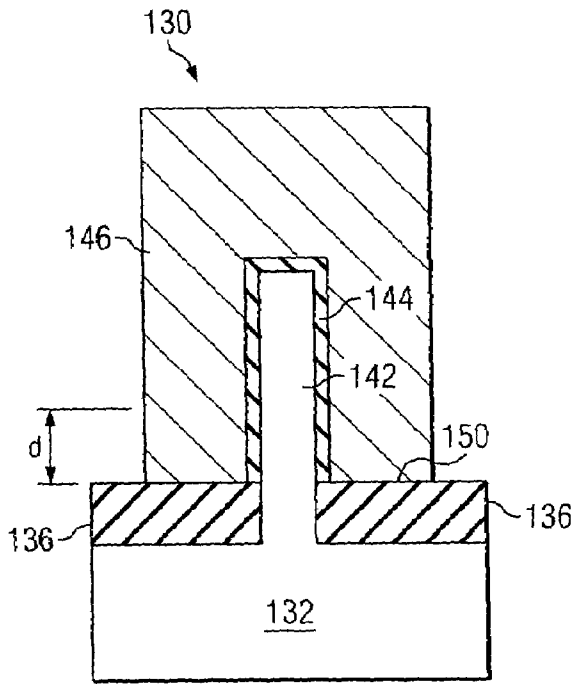

FIG. 4a

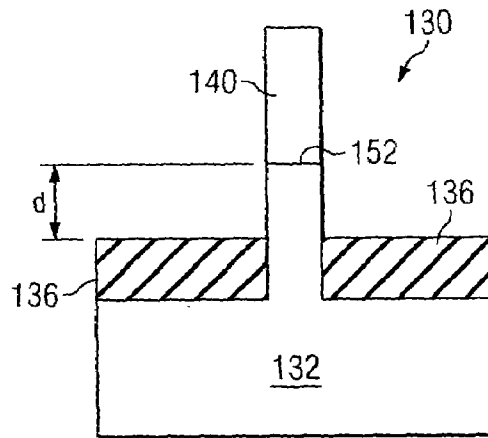

FIG. 4b

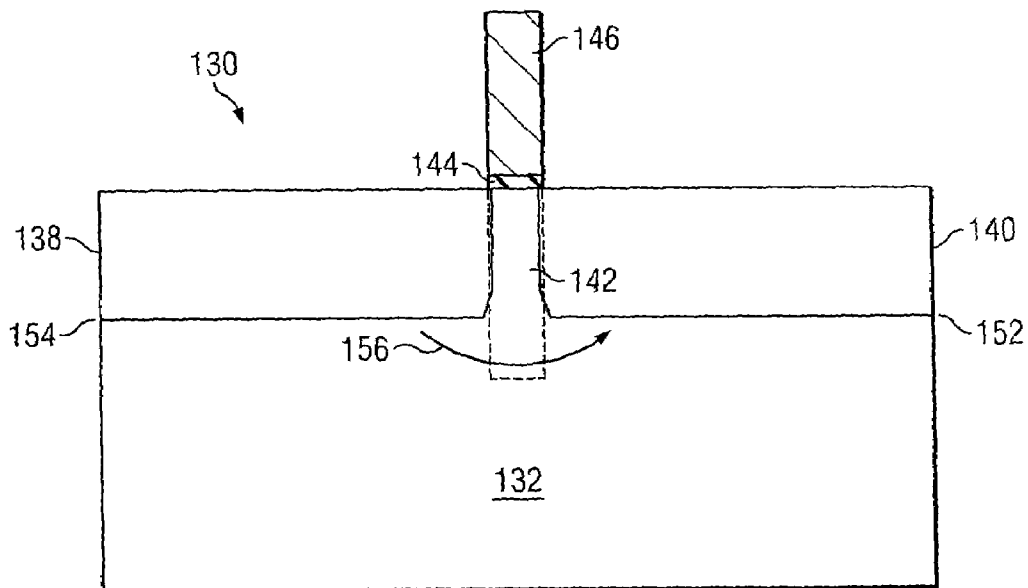

FIG. 4c

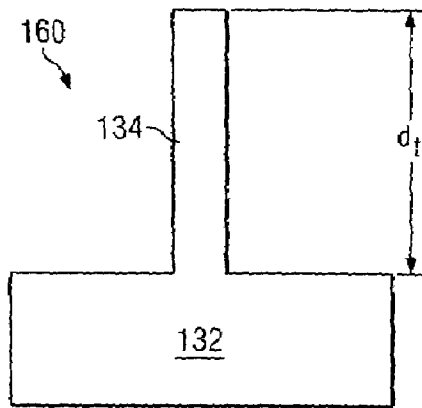

FIG. 5a

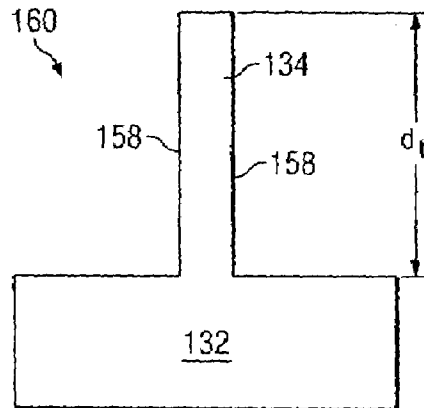

FIG. 6a

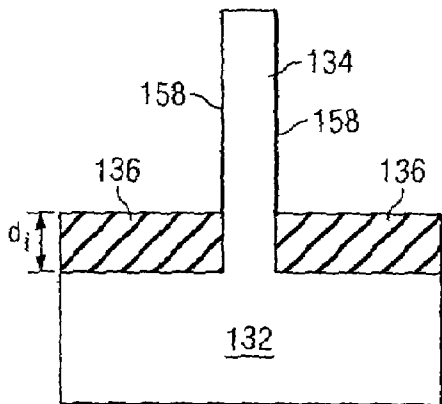

FIG. 5b

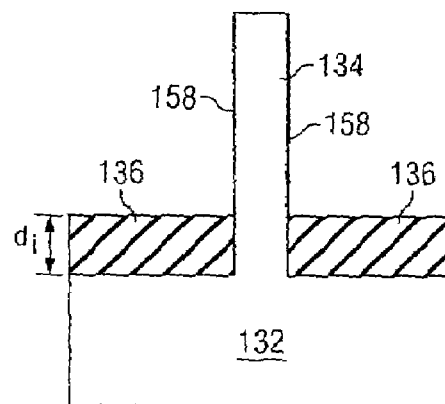

FIG. 6b

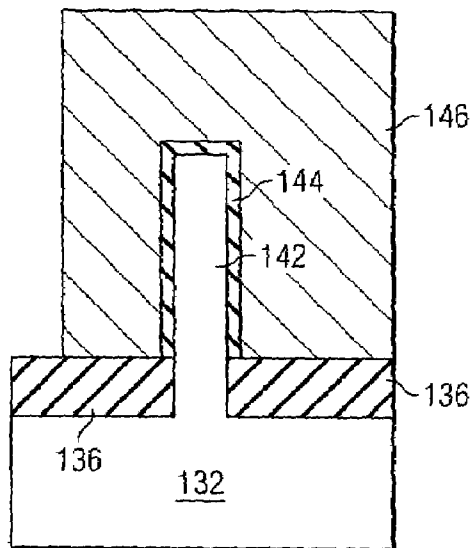

FIG. 5c

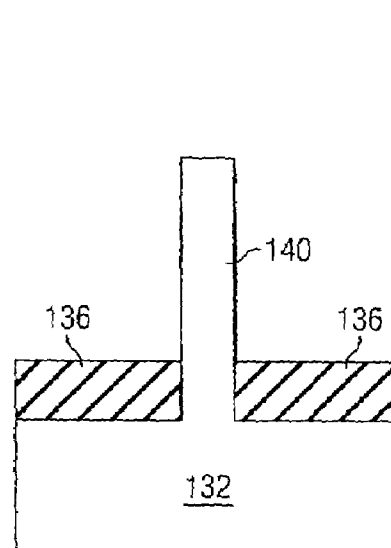

FIG. 6c

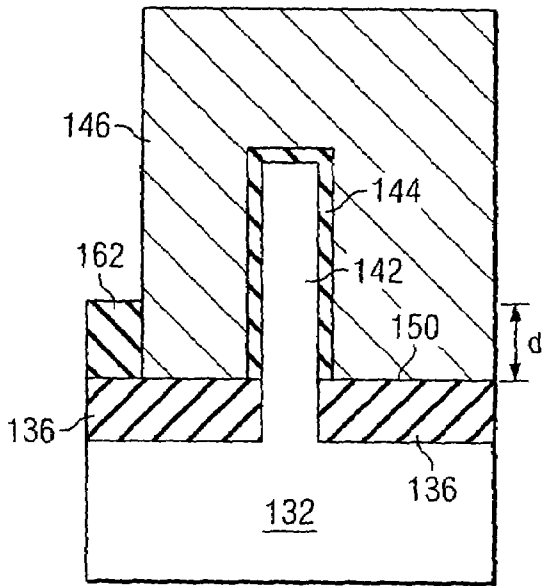

FIG. 5d

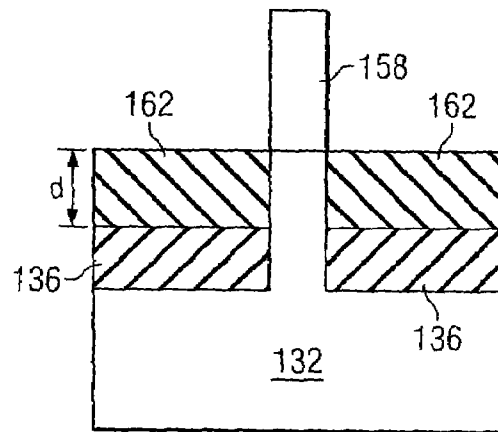

FIG. 6d

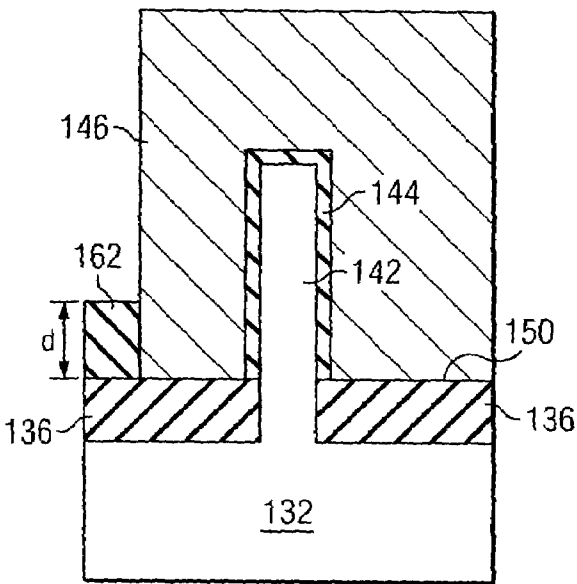

FIG. 5e

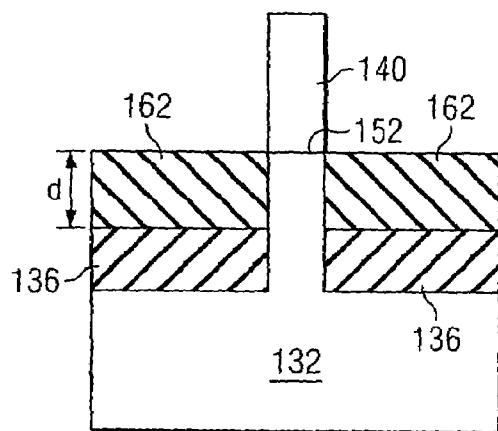

FIG. 6e

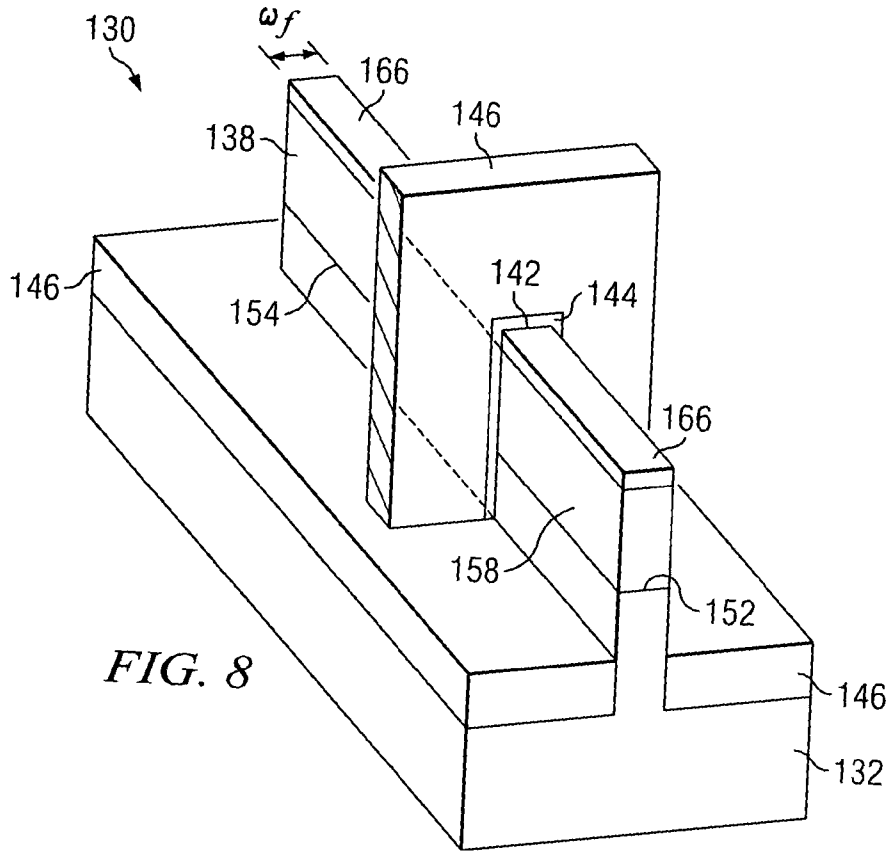

FIG. 8

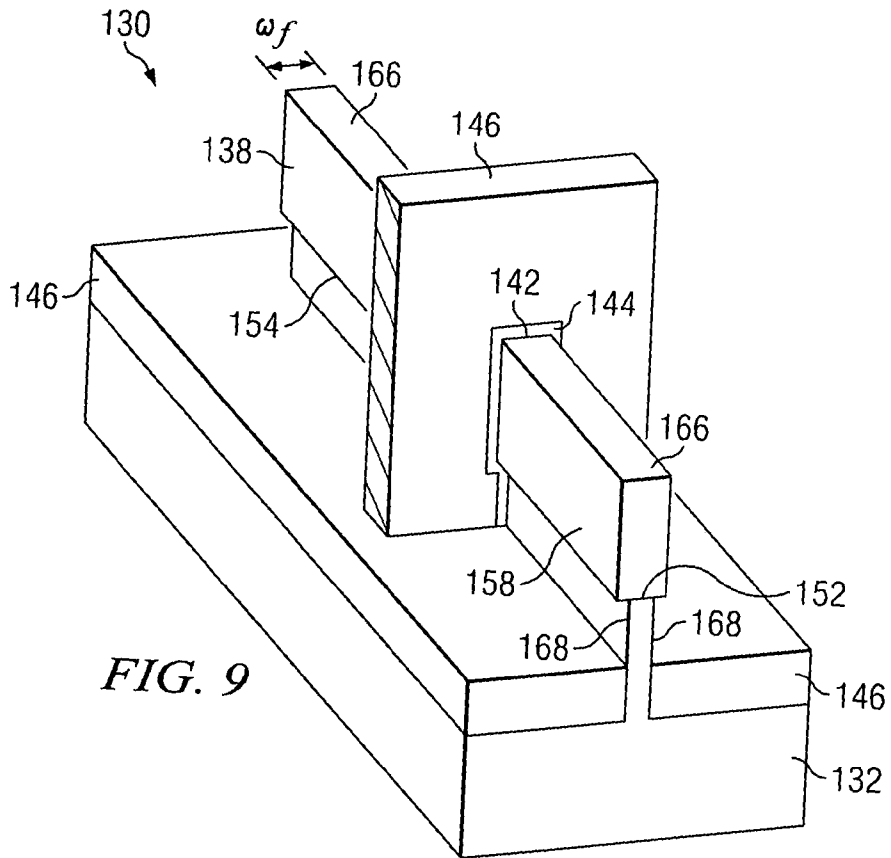

FIG. 9

MULTIPLE-GATE TRANSISTORS FORMED ON BULK SUBSTRATES

This application claims the benefit of U.S. Provisional Application No. 60/495,071, filed on Aug. 13, 2003, entitled "Multiple-Gate Transistors Formed on Bulk Substrates," which application is hereby incorporated herein by reference.

TECHNICAL FIELD

The present invention relates to semiconductor devices and more particularly to the multiple-gate transistors formed on bulk semiconductor substrates.

BACKGROUND

The dominant semiconductor technology used for the manufacture of ultra-large scale integrated (ULSI) circuits is the metal-oxide-semiconductor field effect transistor (MOS-FET) technology. Reduction in the size of MOSFETs has provided continued improvement in speed performance, circuit density, and cost per unit function over the past few decades. As the gate length of the conventional bulk MOS-FET is reduced, however, the source and drain increasingly interact with the channel and gain influence on the channel potential. Consequently, a transistor with a short gate length suffers from problems related to the inability of the gate to substantially control the on and off states of the channel.

Phenomena such as reduced gate control associated with transistors with short channel lengths are termed short-channel effects. Increased body doping concentration, reduced gate oxide thickness, and ultra-shallow source/drain junctions are ways to suppress short-channel effects. However, for device scaling well into the sub-50 nm regime, the requirements for body-doping concentration, gate oxide thickness, and source/drain (S/D) doping profiles become increasingly difficult to meet when conventional device structures based on bulk silicon (Si) substrates are employed.

For device scaling well into the sub-30-nm regime, a promising approach to controlling short-channel effects is to use an alternative transistor structure with more than one gate, i.e. a multiple-gate transistor. Prior art multiple-gate transistors are formed on silicon-on-insulator substrates. A prior art multiple-gate transistor **10** is shown in plan view in FIG. **1**. The structure includes a silicon fin **12** overlying an insulator layer **14**, which overlies a substrate (see element **22** in FIG. **2**). A gate dielectric (see element **20** in FIG. **2**) covers a portion of the silicon fin **12**, and a gate electrode **16** straddles across the silicon fin **12**. The gate dielectric **20** isolates the gate electrode **16** from the silicon fin **12**.

Examples of the multiple-gate transistor include the double-gate transistor, triple-gate transistor, omega field-effect transistor (FET), and the surround-gate or wrap-around gate transistor. A multiple-gate transistor structure is expected to extend the scalability of CMOS technology beyond the limitations of the conventional bulk MOSFET and realize the ultimate limit of silicon MOSFETs. The introduction of additional gates improves the capacitance coupling between the gates and the channel, increases the control of the channel potential by the gate, helps suppress short channel effects, and prolongs the scalability of the MOS transistor.

The simplest example of a multiple-gate transistor is the double-gate transistor as described in U.S. Pat. No. 6,413,802 issued to Hu et al. As illustrated in the cross-sectional

view of FIG. **2a**, the double-gate transistor has a gate electrode **16** that straddles across the channel or the fin-like silicon body **12**, thus forming a double-gate structure. There are two gates, one on each sidewall **18** of the silicon fin **12**. The plan view of the double-gate structure is shown in FIG. **1**.

In U.S. Pat. No. 6,413,802, the transistor channel comprises a thin silicon fin **12** defined using an etchant mask **24** and formed on an insulator layer **14**, e.g. silicon oxide. Gate oxidation is performed, followed by gate deposition and gate patterning to form a double-gate structure overlying the sides of the fin. Both the source-to-drain direction and the gate-to-gate direction are in the plane of the substrate surface.

Another example of the multiple-gate transistor is the triple-gate transistor. A cross-sectional view of a triple-gate transistor structure is provided in FIG. **2b**. The plan view of the triple-gate structure is shown in FIG. **1**. The triple-gate transistor structure has a gate electrode **16** that forms three gates: one gate on the top surface **26** of the silicon body/fin **12**, and two gates on the sidewalls **18** of the silicon body/fin **12**. The triple-gate transistor achieves better gate control than the double-gate transistor because of it has one more gate on the top of the silicon fin.

The triple-gate transistor structure may be modified for improved gate control, as illustrated in FIG. **2c**. Such a structure is also known as the Omega (Ω) field-effect transistor (FET), or simply omega-FET, since the gate electrode **16** has an omega-shape in its cross-sectional view. The encroachment of the gate electrode **16** under the semiconductor fin or body **12** forms an omega-shaped gate structure. It closely resembles the Gate-All-Around (GAA) transistor for excellent scalability, and uses a very manufacturable process similar to that of the double-gate or triple-gate transistor.

The omega-FET has a top gate (adjacent surface **26**), two sidewall gates (adjacent surfaces **18**), and special gate extensions or encroachments **28** under the fin-like semiconductor body **12**. The omega-FET is therefore a field effect transistor with a gate that almost wraps around the body. In fact, the longer the gate extension, i.e., the greater the extent of the encroachment E, the more the structure approaches or resembles the gate-all-around structure. The encroachment of the gate electrode **16** under the silicon body helps to shield the channel from electric field lines from the drain and improves gate-to-channel controllability, thus alleviating the drain-induced barrier lowering effect and improving short-channel performance.

SUMMARY OF THE INVENTION

The preferred embodiment of the present invention provides a multiple-gate transistor that is formed on a bulk substrate. Bulk silicon substrates are cheaper than silicon-on-insulator substrates. Therefore, the availability of a technology that forms multiple-gate transistors on bulk substrates will enable future device scaling at a significantly reduced cost.

In accordance with a preferred embodiment of the preferred embodiment, a structure and method for the fabrication of multiple-gate transistors on bulk substrates includes depletion-mode bulk multiple-gate transistors and accumulation mode bulk multiple-gate transistors, bulk double-gate transistor, bulk triple-gate transistor, and bulk omega-gate transistor and multiple-gate transistors formed on bulk substrates may be integrated with conventional bulk transistors.

Prior art multiple-gate transistors such as the double-gate transistor, the triple-gate transistor, and the omega-FET are formed on silicon-on-insulator substrates. This patent teaches a structure and method for forming multiple-gate transistors on bulk substrate. Many of the multiple-gate transistors taught here achieve low cost of manufacture and enable scalability of bulk transistors to significantly reduced feature sizes.

In one aspect, the present invention teaches a multiple-gate transistor that includes a semiconductor fin formed in a portion of a bulk semiconductor substrate. A gate dielectric overlies a portion of the semiconductor fin and a gate electrode overlies the gate dielectric. A source region and a drain region are formed in the semiconductor fin oppositely adjacent to the gate electrode. In the preferred embodiment, the bottom surface of the gate electrode is lower than either the source-substrate junction or the drain-substrate junction.

In one method of forming a multiple-gate transistor according to a preferred embodiment, a bulk semiconductor substrate is provided. A semiconductor fin is formed on the bulk semiconductor substrate and isolation regions are provided on sides of the semiconductor fin. A gate dielectric and a gate electrode are formed on a portion of the semiconductor fin. A source region and a drain region are formed in the semiconductor fin. Once again, in the preferred embodiment the source-substrate junction or drain-substrate junction is higher than the bottom surface of the gate electrode.

In another embodiment of the present invention, portions of a silicon substrate are etched to form at least one semiconductor fin. A gate dielectric layer is formed over the semiconductor fin and a gate electrode layer is formed over the gate dielectric layer. Portions of the gate electrode layer are etched to form a gate electrode so that the gate electrode overlies sidewalls and a top surface of the semiconductor fin. A region of material, e.g., dielectric, is formed adjacent portions of the semiconductor fin not underlying the gate electrode such that a sidewall of the semiconductor fin extends above an upper surface of the region of material. The sidewall of the semiconductor fin above the region of material can then be doped.

BRIEF DESCRIPTION OF THE DRAWINGS

For a more complete understanding of the present invention, and the advantages thereof, reference is now made to the following descriptions taken in conjunction with the accompanying drawing, in which:

FIG. 1 is a plan view illustrating the multiple-gate transistor of the prior art;

FIG. 2a is a cross-sectional view of the double-gate transistor of the prior art;

FIG. 2b is a cross-sectional view of the triple-gate transistor of the prior art;

FIG. 2c is a modified structure of the triple-gate transistor shown in FIG. 2b;

FIG. 3 is a three-dimensional view of a triple-gate transistor embodiment of the present invention;

FIGS. 4a-4c provide cross-sectional views of the triple-gate transistor of FIG. 3;

FIGS. 5a-5e and 6a-6e illustrate the fabrication of a triple-gate transistor of the present invention;

FIG. 7 is a perspective view of another embodiment triple-gate transistor of the present invention;

FIG. 8 is a perspective view of a double-gate transistor of the present invention; and

FIG. 9 is a perspective view of an omega-gate transistor of the present invention.

DETAILED DESCRIPTION OF ILLUSTRATIVE EMBODIMENTS

The making and using of the presently preferred embodiments are discussed in detail below. It should be appreciated, however, that the present invention provides many applicable inventive concepts that can be embodied in a wide variety of specific contexts. The specific embodiments discussed are merely illustrative of specific ways to make and use the invention, and do not limit the scope of the invention.

The preferred embodiment relates to the field of semiconductor devices and more particularly to semiconductor devices with multiple gates. Aspects of this invention provide a structure and method for forming multiple-gate transistors on bulk silicon substrates.

FIG. 3 shows a three-dimensional perspective of a triple-gate transistor 130 formed on a bulk substrate 132 according to a first embodiment of this invention. The substrate 132 material can be any semiconductor material. For example, the substrate 132 can be an elemental semiconductor such as silicon or germanium, an alloy semiconductor such as silicon-germanium, or a compound semiconductor such as gallium arsenide. In the preferred embodiment, the substrate 132 comprises monocrystalline silicon.

The bulk triple-gate transistor 130 includes a semiconductor fin 134 formed on the bulk substrate 132. Isolation regions 136 are formed between semiconductor fins (one fin 134 as shown), or between a semiconductor fin 134 and another active region (not shown). The isolation region 136 may comprise silicon oxide, silicon oxynitride, silicon nitride, or combinations thereof. Mesa isolation can also be used.

The semiconductor fin 134 includes a doped source region 138 and a doped drain region 140. The source and drain regions 138 and 140 sandwich a channel region 142. A gate dielectric 144 overlies the channel portion 142 of the semiconductor fin 134, as shown in FIG. 3. In fact, the gate dielectric 144 insulates the semiconductor fin 134 from the gate electrode 146.

The gate electrode 146 straddles across fin-like active region 134. The sidewall surfaces 148 of the semiconductor fin 134 are used for current conduction. In the preferred embodiment, a significant amount of source-to-drain current in the transistor is carried along the sidewall surfaces 148. The semiconductor fin 134 has a predetermined fin width w_f and a drain that has a depth w_d from the top surface of the semiconductor fin. Essentially, the effective device width of the transistor is a function of w_d and w_f . A larger w_d or w_f would result in a larger amount of drive current.

Cross-sectional views of the triple-gate transistor of FIG. 3 in the planes of 4a-4a', 4b-4b', and 4c-4c' are illustrated in FIGS. 4a, 4b, and 4c, respectively. FIG. 4a shows cross-sectional view in the plane that cuts through the gate electrode 146, the gate dielectric 144, and the channel region 142 of semiconductor fin 134. The gate electrode 146 has a bottom surface 150 that touches the isolation region 136.

A cross-sectional view in the plane of 4b-4b', which is parallel to plane 4a-4a', is shown in FIG. 4b. The view cuts through the drain region 140 of the transistor 130. One feature of the design is that the bottom surface 150 of the gate electrode 146 is below the level of the drain-substrate junction 152 or the level of the source-substrate junction 154.

Referring now to FIGS. 4a and 4b, the drain-substrate junction 152 depicted in FIG. 4b is at a level that is higher than the level of the bottom surface 150 of the gate electrode 146 depicted in FIG. 4a. The difference d in the heights of

the drain-substrate junction **152** and the bottom surface **150** of the gate electrode **146** may be in the range of about 50 angstroms to about 500 angstroms, and preferably about 200 angstroms.

FIG. **4c** shows a cross-sectional view in the plane that cuts through the gate electrode **146**, the gate dielectric **144**, the channel region **142**, the source region **138**, and the drain region **140**. FIG. **4c** also shows a potential leakage current path **156** between the source and the drain regions **138** and **140**. The gate electrode **146** above or below the plane of the page (i.e., plane **4c-4c'**) is drawn in dashed lines in FIG. **4c**, showing that the gate electrode **146** is in the vicinity of the potential leakage current path. Therefore, by having the gate electrode **146** extend below the source-substrate junction **154** or the drain-substrate junction **152**, and positioning the gate electrode **146** in the vicinity of the potential leakage path **156**, this embodiment ensures that the gate electrode **146** exerts considerable influence on the potential leakage path **156** to suppress the leakage.

In various aspects of this invention, the source and drain regions **138** and **140** may be doped n-type, and the body region **142** may be doped p-type to form an n-channel depletion-mode transistor, or the source and drain regions **138** and **140** may be doped p-type, and the body region **142** doped n-type to form a p-channel depletion-mode transistor. Alternatively, accumulation mode transistors may be formed by having the body regions **142** doped the same type as the source and drain regions **138** and **140**. For example, the source **138**, drain **140**, and body **142** may all be doped n-type to form an n-channel accumulation mode transistor.

A method of forming the multiple-gate transistor of FIG. **3** will now be described with reference to FIGS. **5a-5e** (collectively FIG. **5**) and FIGS. **6a-6e** (collectively FIG. **6**). FIGS. **5** and **6** show the device cross-section in two parallel planes at the various stages of device fabrication. In particular, FIG. **5** shows the device **130** in the plane **4a-4a'** of FIG. **3** and FIG. **6** shows the device **130** in the plane **4b-4b'** of FIG. **3**. As before, the planes **4a-4a'** and **4b-4b'** are parallel to each other. A perspective view of a transistor after additional steps are performed is shown in FIG. **7**.

The starting material is a semiconductor substrate **132** that may be an elemental semiconductor, an alloy semiconductor, or a compound semiconductor. The starting material is preferably a silicon substrate, preferably about 300 mm in diameter. At least one semiconductor fin **134** is formed by patterning the semiconductor substrate, as shown in FIGS. **5a** and **6a**. The semiconductor fin patterning process may be accomplished by forming a mask (not shown) over the semiconductor **132**, followed by the etching of the semiconductor **132** to a predetermined depth d_f . The mask may comprise a commonly used mask material such as photoresist or silicon oxide or silicon nitride, combinations thereof. The trench depth d_f may be in the range of about 200 angstroms to about 6000 angstroms, preferably about 3000 angstroms.

The trench depth d_f may be the same for all semiconductor fins **134** formed in substrate **132**. Alternatively, trenches of different depths can be formed on the same bulk semiconductor substrate **132**. This embodiment allows for transistors with different drive currents to be formed on the same chip. This embodiment can be realized by selectively removing portions of the trench mask (not shown) during the etching process so that some trenches are etched for longer.

The mask may or may not be removed after the etching step. If it is removed, as in the preferred embodiment, a

triple-gate transistor will be formed. If it is not removed, a double-gate transistor, as illustrated in FIG. **8**, can be formed.

Referring now to FIGS. **5b** and **6b**, isolation regions **136** with a depth of d_i are formed in the trench **160**. The isolation depth d_i may be in the range of about 20 angstroms to about 6000 angstroms, preferably about 200 angstroms. In the preferred embodiment, the ratio of d_f/d_i ranges from about 1.2:1 to about 6:1, preferably about 2:1. The semiconductor fin has sidewall surfaces **158** as shown.

A gate dielectric layer **144** is then formed on the semiconductor fin **134**. Due to subsequent processing, the gate dielectric **144** is shown in FIG. **5c** but not in FIG. **6c**. The gate dielectric may be formed by thermal oxidation, chemical vapor deposition, sputtering, or any other methods known and used in the art for forming a gate dielectric. Depending on the technique of gate dielectric formation, the gate dielectric **144** thickness on the top of the fin **134** may be different from the gate dielectric thickness on the fin sidewall. In one embodiment, the gate dielectric thickness on the top surface of the fin is less than about 20 angstroms.

The gate dielectric may be formed from a material such as silicon dioxide or silicon oxynitride with a thickness ranging from about 3 angstroms to about 100 angstroms, preferably about 10 angstroms or less. The gate dielectric may also be formed from a high permittivity (high-k) material such as lanthanum oxide (La_2O_3), aluminum oxide (Al_2O_3), hafnium oxide (HfO_2), hafnium oxynitride (HfON), or zirconium oxide (ZrO_2), or combinations thereof, with an equivalent oxide thickness of about 3 angstroms to about 100 angstroms.

Next, the gate electrode **146** material is deposited. The gate electrode material is a conductive material and may be amorphous or polycrystalline silicon (poly-Si), polycrystalline silicon-germanium (poly-SiGe), a metallic nitride, a metallic silicide, a metallic oxide, or a metal. Examples of metallic nitrides include tungsten nitride, molybdenum nitride, titanium nitride, and tantalum nitride, or their combinations. Examples of metallic silicide include tungsten silicide, titanium silicide, cobalt silicide, nickel silicide, platinum silicide, erbium silicide, or their combinations. Examples of metallic oxides include ruthenium oxide, indium tin oxide, or their combinations. Examples of metal include tungsten, titanium, aluminum, copper, molybdenum, nickel, platinum, and others.

The gate electrode **146** material may be deposited by chemical vapor deposition (CVD), by sputter deposition, or by other techniques known and used in the art for depositing conductive materials. The thickness of the gate electrode material may be in the range of about 200 angstroms to about 4000 angstroms, preferably about 1500 angstroms. The top surface of the gate electrode **146** material usually has a non-planar top surface, and may be planarized (e.g., chemical-mechanical polished) prior to patterning of the gate electrode **146** material or gate etch. Ions may or may not be introduced into the gate electrode **146** material at this point. Ions may be introduced, for example, by ion implantation techniques.

The next step is the definition of the gate electrode **146**. A mask material (not shown) is formed on the gate electrode material, and the gate electrode **146** is formed by an etching process, preferably an anisotropic etch (e.g., dry plasma etching process), to give the cross-sections in FIGS. **5c** and **6c**. In this example, gate dielectric **144** has also been patterned, although this step is not necessary.

A dielectric layer **162** is then formed to cover a portion of the sidewall surface **158** of the semiconductor fin **134**, not

already covered by isolation region **136**. Referring now to FIGS. **5d** and **6d**, the layer **162** is formed such that a sidewall **158** semiconductor fin **134** extends above the upper surface of layer **162**. This dielectric layer **162** allows the formation of the source and drain regions **138** and **140** such that the drain-substrate junction **152** or the source-substrate junction **154** is at a higher level than the bottom surface **150** of the gate electrode **146**. In the preferred embodiment, the drain-substrate junction **152** or the source-substrate junction **154** is defined to be the position where the doping concentration in the source or drain region **138** is at the 10^{18} cm^{-3} level. In the preferred embodiment, dielectric layer **162** comprises silicon oxide.

In the preferred embodiment, the material region **162** is formed to a thickness between about 50 angstroms and about 500 angstroms, preferably about 200 angstroms. The height of the exposed portion of sidewall **158** is typically in the range of about 500 angstroms to about 2000 angstroms, preferably about 1000 angstroms. As a result, the ratio of the thickness of the material region **162** to the height of the exposed portion of the sidewall **158** is preferably between about 1:1 to about 1:20

The source and drain regions **138** and **140** are formed next as shown in FIGS. **5e** and **6e**. The formation of the source and drain regions **138** and **140** may involve several steps. In the preferred embodiment, an ion implantation process is first performed to dope the source and drain regions **138** and **140** immediately adjacent to the channel region **142**. The channel region **142** is the portion of the semiconductor fin **134** wrapped around by the gate dielectric **144** and the gate electrode **146**.

Spacers (**164** in FIG. **7**) are then formed on the sidewalls of the gate electrode **146**. The spacers **164** may be formed by deposition of a spacer material(s) followed by anisotropic etching of the spacer material(s) to form the spacers **164**. The spacer is formed from a dielectric material, preferably silicon nitride (e.g., Si_3N_4). The spacer material may also be formed from a stack of dielectric materials, such as a silicon nitride layer overlying a silicon oxide layer. FIG. **7** shows a three-dimensional perspective of the transistor structure with spacers **164** and the dielectric layer **162**.

A selective epitaxy may additionally be performed to increase the width and/or height of the fin **134** in the source and drain regions **138** and **140**. The selective epitaxy results in epitaxial growth in the source and drain regions **138** and **140**, and perhaps the gate electrode region **146**. The epitaxy can be performed uniformly for all fins **134** on a single substrate **132** or can be performed to different levels (including none) for different fins on a single substrate.

An optional ion implantation is then performed to dope the source and drain regions **138** and **140**. The ion implantation process is performed if the selective epitaxy does not incorporate dopants into the grown regions during epitaxial growth. Conductive materials (not shown) such as suicides may be formed on the source and drain regions (**138** and **140**) to increase the conductance in these regions.

FIG. **8** shows a structure for a double gate transistor. This device is similar to the triple gate device of FIG. **7** but also includes an etch mask **166**, as was discussed above. In the preferred embodiment, the etch mask **166** is formed of silicon oxynitride and has a thickness between about 20 angstroms and about 500 angstroms.

A transistor with an omega-shaped gate electrode, as shown in FIG. **9**, can also be formed by slightly modifying the fabrication process just described. For example, during the definition of the semiconductor fin in FIGS. **5a** and **6a**, a two-step etch may be employed. A first etch step may

employ a highly anisotropic plasma etch process with a negligible lateral etch rate. A second etch step may employ a less anisotropic etch so that some lateral etch takes place, resulting in a narrower semiconductor fin at the base. The two-step etch will result in a semiconductor fin with a wider fin width at the top, e.g., source **138** and drain **140**, and a narrower fin width at the bottom **168**. The remaining fabrication steps follow those as described above. The resulting transistor structure is shown in FIG. **9**.

The following references are related to aspects of the preferred embodiment and are hereby incorporated herein by reference:

- [1] C. Hu et al., University of California, FinFET transistor structures having a double gate channel extending vertically from a substrate and methods of manufacture, U.S. Pat. No. 6,413,802.
- [2] K. P. L. Muller et al., International Business Machines Corporation, Jun. 26 2001, Planarized Si fin device, U.S. Pat. No. 6,252,284.
- [3] K. P. L. Muller et al., International Business Machines Corporation, Aug. 13 2002, Process for making planarized silicon fin device, U.S. Pat. No. 6,432,829.
- [4] B. Yu, Advanced Micro Devices, Inc., May 21 2002, Double-gate transistor formed in a thermal process, U.S. Pat. No. 6,391,695.
- [5] B. Yu, Advanced Micro Devices, Inc., May 21 2002, Process for forming multiple active lines and gate-all-around MOSFET, U.S. Pat. No. 6,391,782.
- [6] B. Yu et al., Advanced Micro Devices, Inc., Sep. 17 2002, CMOS inverter configured from double gate MOSFET and method of fabricating same, U.S. Pat. No. 6,451,656.
- [7] M. Jeong et al., International Business Machines Corporation, Dec. 10, 2002, Variable threshold voltage double gated transistors and method of fabrication, U.S. Pat. No. 6,492,212.
- [8] X. Huang et al., "Sub-50 nm p-channel finFET," *IEEE Trans. Electron Devices*, vol. 48, no. 5, pp. 880–886, May 2001.
- [9] F.-L. Yang et al., "35 nm CMOS FinFETs," *Symposium on VLSI Technology, Digest of Technical Papers*, pp. 109–110, June 2002.
- [10] H.-S. P. Wong, "Beyond the conventional transistor," *IBM J. Research and Development*, vol. 46, no. 2/3, pp. 133–168, March/May 2002.
- [11] R. Chau et al., "Advanced depleted-substrate transistors: single-gate, double-gate, and tri-gate", 2002 International Conference on Solid State Devices and Materials, Nagoya, Japan, pp. 68–69, September 2002.
- [12] F.-L. Yang et al., "25 nm CMOS Omega-FETs," *International Electron Device Meeting*, Dig. Technical Papers, December 2002.
- [13] J. P. Colinge et al., "Silicon-on-insulator gate-all-around device," *International Electron Device Meeting*, Dig. Technical Papers, pp. 595–598, December 1990.
- [14] E. Leobandung et al., "Wire-channel and wrap-around-gate metal-oxide-semiconductor field-effect transistors with a significant reduction of short channel effects," *J. Vacuum Science and Technology B*, vol. 15, no. 6, pp. 2791–2794, 1997.

While several embodiments of the invention, together with modifications thereof, have been described in detail herein and illustrated in the accompanying drawings, it will be evident that various modifications are possible without departing from the scope of the preferred embodiment. The examples given are intended to be illustrative rather than exclusive. The drawings may not necessarily be to scale and features may be shown in a schematic form.

What is claimed is:

1. A method of forming a multiple-gate transistor, the method comprising:
 - providing a bulk semiconductor substrate;
 - forming a semiconductor fin, in the bulk semiconductor substrate;
 - forming isolation regions on sides of the semiconductor fin;
 - forming a gate dielectric and a gate electrode on a portion of the semiconductor fin, the gate electrode having a bottom surface;
 - after forming the gate electrode, forming a masking layer over the isolation region and covering a lower portion of the semiconductor fin; and
 - forming a source region and a drain region in uncovered portions of the semiconductor fin, using the masking layer as a mask, the source region having a source-substrate junction and the drain region having a drain-substrate junction, the source-substrate junction or drain-substrate junction being higher than the bottom surface of the gate electrode by an amount based on a thickness of the masking layer.
2. The method of claim 1 wherein the source-substrate junction and the drain-substrate junction is higher than the bottom surface of the gate electrode by a distance of between about 50 angstroms and about 500 angstroms.
3. The method of claim 1 wherein forming a semiconductor fin comprises:
 - forming a mask over the bulk semiconductor substrate; and
 - etching exposed regions of the semiconductor substrate to form the semiconductor fin.
4. The method of claim 3 further comprising removing the mask.
5. The method of claim 4 wherein the mask comprises a photoresist.
6. The method of claim 4 wherein the mask comprises a material selected from the group consisting of silicon oxide, silicon oxynitride, silicon nitride, and combinations thereof.
7. The method of claim 1 and further comprising strapping the source and drain regions with a conductive material.
8. The method of claim 1 and further comprising forming spacers on sides of the gate electrode.
9. The method of claim 1 and further comprising performing selective epitaxy on the source and drain regions.
10. The method of claim 1 wherein the semiconductor fin comprises silicon.
11. The method of claim 1 wherein the semiconductor fin comprises silicon and germanium.
12. The method of claim 1 wherein the gate dielectric comprises silicon oxide or silicon oxynitride or silicon nitride.
13. The method of claim 1 wherein the gate dielectric comprises a high permittivity material.
14. The method of claim 1 wherein the gate dielectric comprises a material selected from the group consisting of lanthanum oxide, aluminum oxide, hafnium oxide, hafnium oxynitride, and zirconium oxide, and combinations thereof.
15. The method of claim 1 wherein the gate dielectric comprises a material with a relative permittivity greater than about 5.
16. The method of claim 1 wherein the gate dielectric has a thickness of between about 3 and about 100 angstroms.
17. The method of claim 1 wherein the gate electrode comprises polycrystalline or amorphous silicon.
18. The method of claim 1 wherein the gate electrode comprises poly-SiGe.

19. The method of claim 1 wherein the gate electrode comprises a metallic nitride.
20. The method of claim 1 wherein the gate electrode comprises a metallic suicide.
21. The method of claim 1 wherein the gate electrode comprises a metal.
22. The method of claim 1 wherein the multiple-gate transistor is a triple-gate transistor.
23. The method of claim 1 wherein the multiple-gate transistor is a double-gate transistor.
24. The method of claim 1 wherein the multiple-gate transistor is an omega-gate transistor.
25. The method of claim 1, wherein the source-substrate junction or drain-substrate junction being higher than the bottom surface of the gate electrode by at least about 28 angstroms.
26. A method of forming a semiconductor device, the method comprising:
 - providing a silicon substrate;
 - etching portions of the silicon substrate to form at least one semiconductor fin;
 - forming a gate dielectric layer over the semiconductor fin;
 - forming a gate electrode layer over the gate dielectric layer;
 - etching portions of the gate electrode layer to form a gate electrode, the gate electrode overlying sidewalls and a top surface of the semiconductor fin;
 - after etching portions of the gate electrode layer, forming a region of material adjacent portions of the semiconductor fin not underlying the gate electrode such that a sidewall of the semiconductor fin extends above an upper surface of the region of material; and
 - after forming the region of material, doping the sidewall of the semiconductor fin above the region of material.
27. The method of claim 26 and further comprising forming an isolation region adjacent the semiconductor fin, the isolation region being formed after etching portions of the silicon substrate but before forming the gate dielectric layer.
28. The method of claim 26 and further comprising forming a masking material over the silicon substrate and wherein the step of etching portions of the silicon substrate is performed in alignment with the masking material.
29. The method of claim 28 and further comprising removing the masking material after the semiconductor fin is formed.
30. The method of claim 28 wherein the gate dielectric layer and the gate electrode layer are formed over the masking material.
31. The method of claim 26 wherein forming a region of material comprises depositing a dielectric layer.
32. The method of claim 26 wherein forming a gate dielectric layer comprises forming a layer of a material with a relative permittivity greater than about 5.
33. The method of claim 26 and further comprising forming an isolation region adjacent the semiconductor fin.
34. The method of claim 26 and further comprising removing the region of material after doping the sidewall.
35. The method of claim 27 wherein forming an isolation region comprises depositing an oxide material.
36. The method of claim 26, wherein doping the sidewall comprises doping the sidewall in alignment with the region of material.

UNITED STATES PATENT AND TRADEMARK OFFICE
CERTIFICATE OF CORRECTION

PATENT NO. : 7,172,943 B2
APPLICATION NO. : 10/669395
DATED : February 6, 2007
INVENTOR(S) : Yeo et al.

Page 1 of 1

It is certified that error appears in the above-identified patent and that said Letters Patent is hereby corrected as shown below:

Column 10, line 4; delete "suicide" insert --silicide--
Column 10, line 15; delete "28" insert --50--
Column 10, line 16; delete "angstroms" insert--angstroms--

Signed and Sealed this

Seventeenth Day of April, 2007

A handwritten signature in black ink on a light gray dotted background. The signature reads "Jon W. Dudas" in a cursive style.

JON W. DUDAS

Director of the United States Patent and Trademark Office