



US 20060286984A1

(19) **United States**

(12) **Patent Application Publication** (10) **Pub. No.: US 2006/0286984 A1**

Bonner

(43) **Pub. Date: Dec. 21, 2006**

(54) **MULTI-MODE HANDSET SERVICES**

(52) **U.S. Cl. 455/445; 455/436**

(75) **Inventor: Thomas W. Bonner, Smyrna, GA (US)**

(57) **ABSTRACT**

Correspondence Address:

**Himanshu S. Amin
AMIN & TUROCY, LLP
National City Center, 24TH Floor
1900 East 9TH Street
Cleveland, OH 44114 (US)**

Delivery of dual-mode GSM/WiFi voice and data services to a consumer with support for transparent network registrations and handovers between GSM and WiFi networks. Aspects include transparently and wirelessly automating call redirection procedures of calls and data (e.g., SMS messages) to legacy telephone devices, to GSM handsets via broadband, and to VoIP devices via broadband. An indoor network is treated as a pseudo visitor PLMN (VPLMN) by the home PLMN (HPLMN) which does not require GSM radio coverage in an indoor network. This innovation provides a means for automating a process of redirecting a subscriber's calls from the GSM network to the subscriber's home network, and can utilize a Bluetooth access point to provide a beacon signal for triggering redirection.

(73) **Assignee: Cingular Wireless LLC, Atlanta, GA**

(21) **Appl. No.: 11/154,775**

(22) **Filed: Jun. 16, 2005**

Publication Classification

(51) **Int. Cl.
H04Q 7/20 (2006.01)**

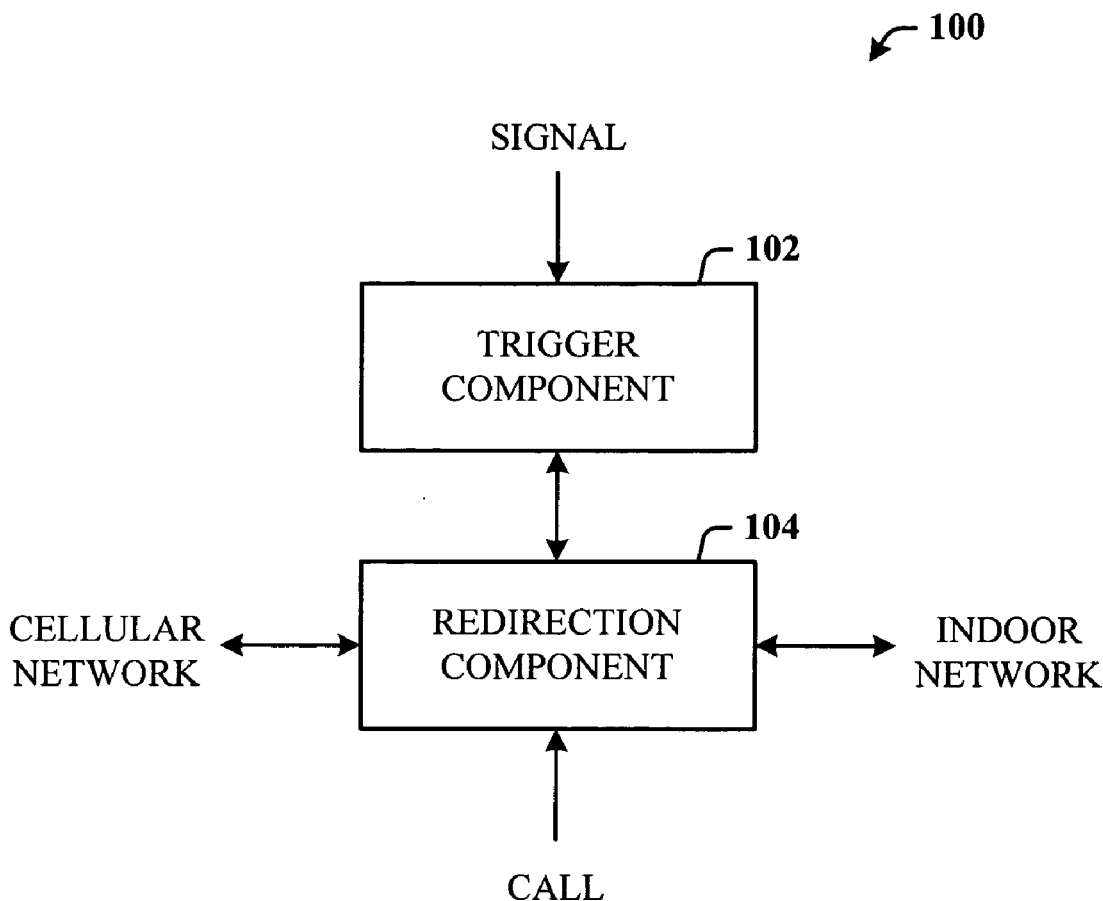

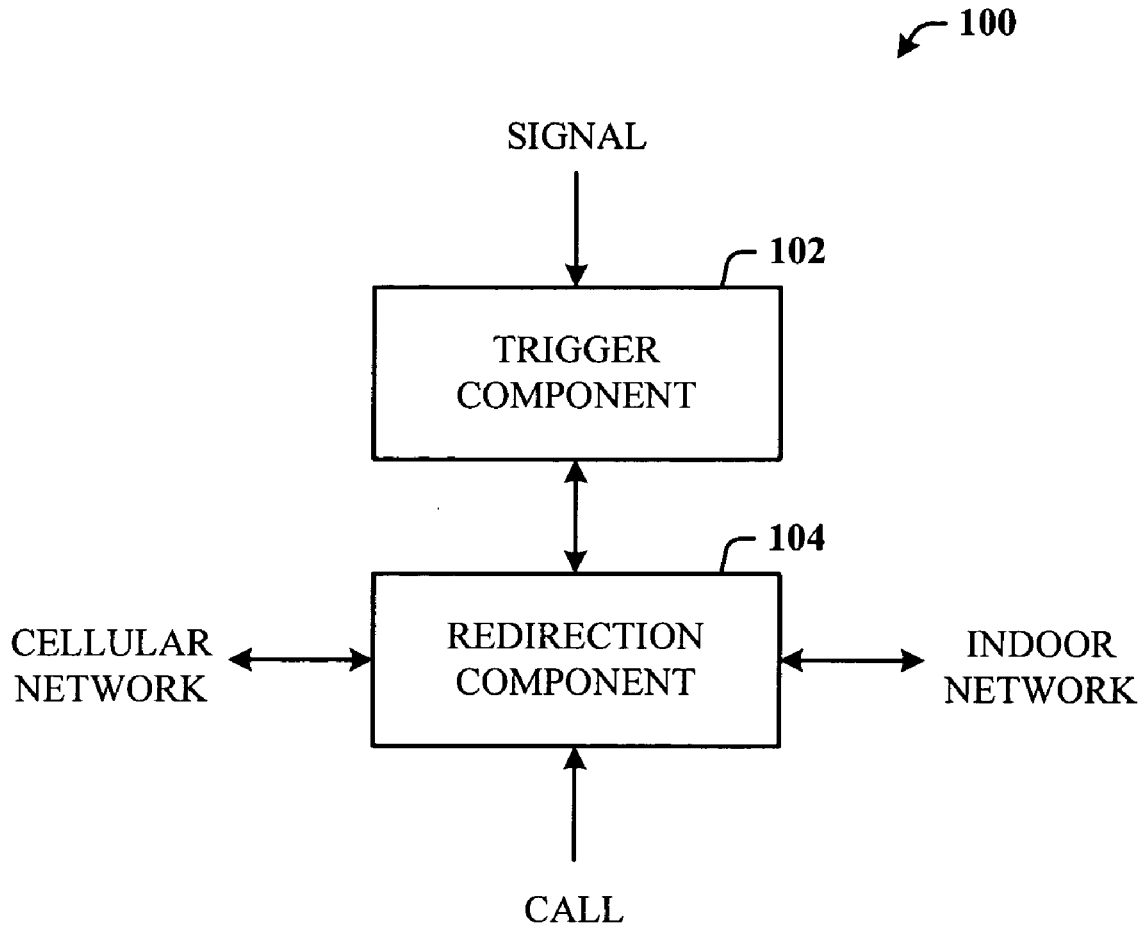

FIG. 1

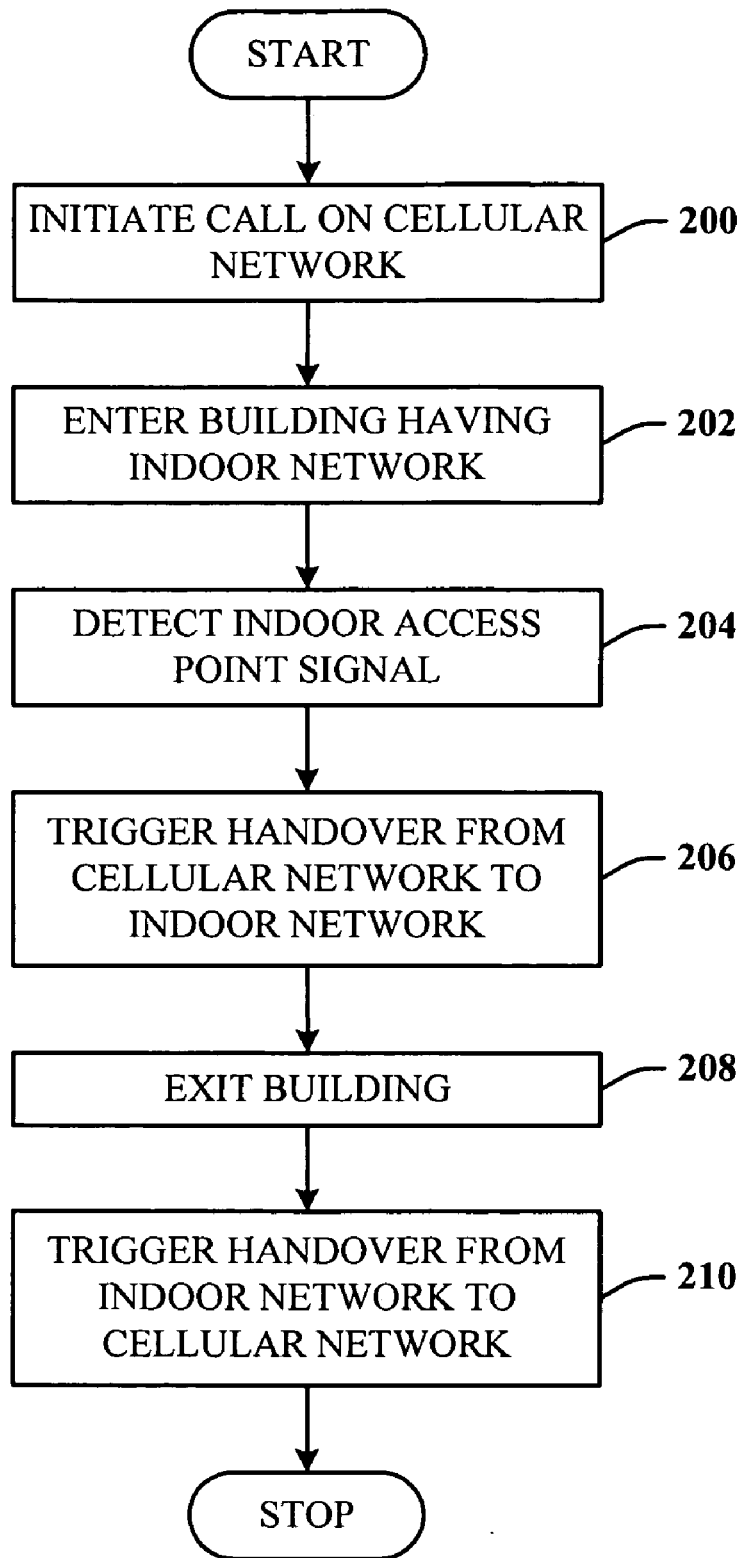

FIG. 2

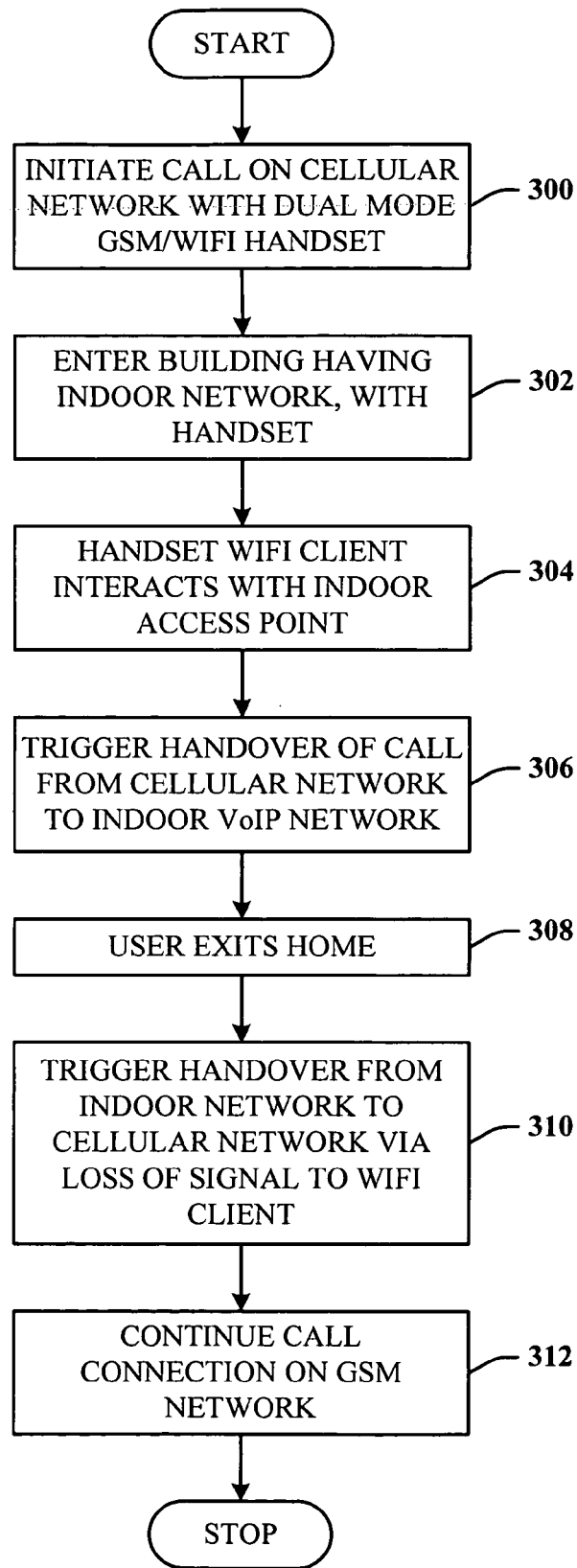

FIG. 3

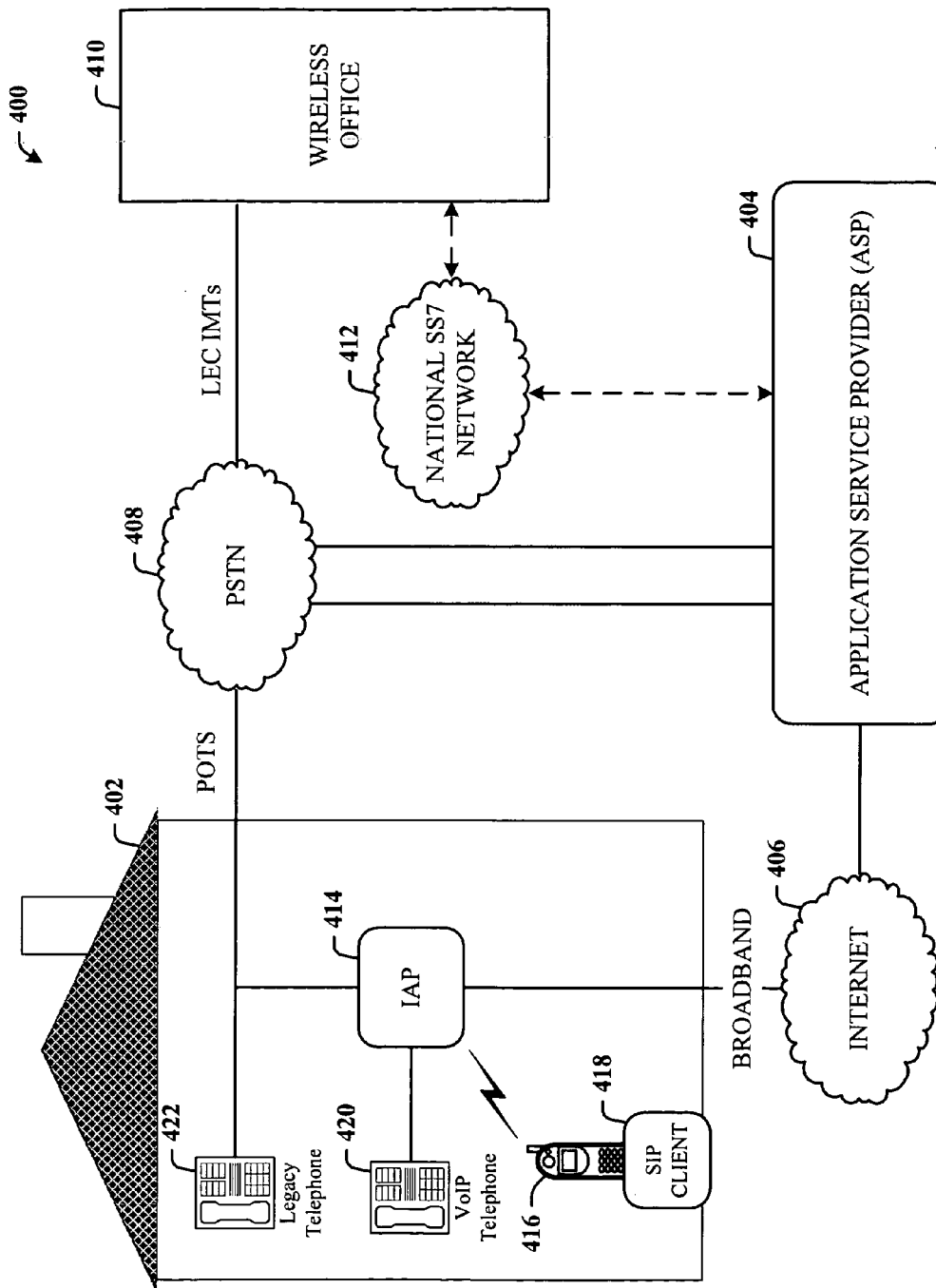

FIG. 4

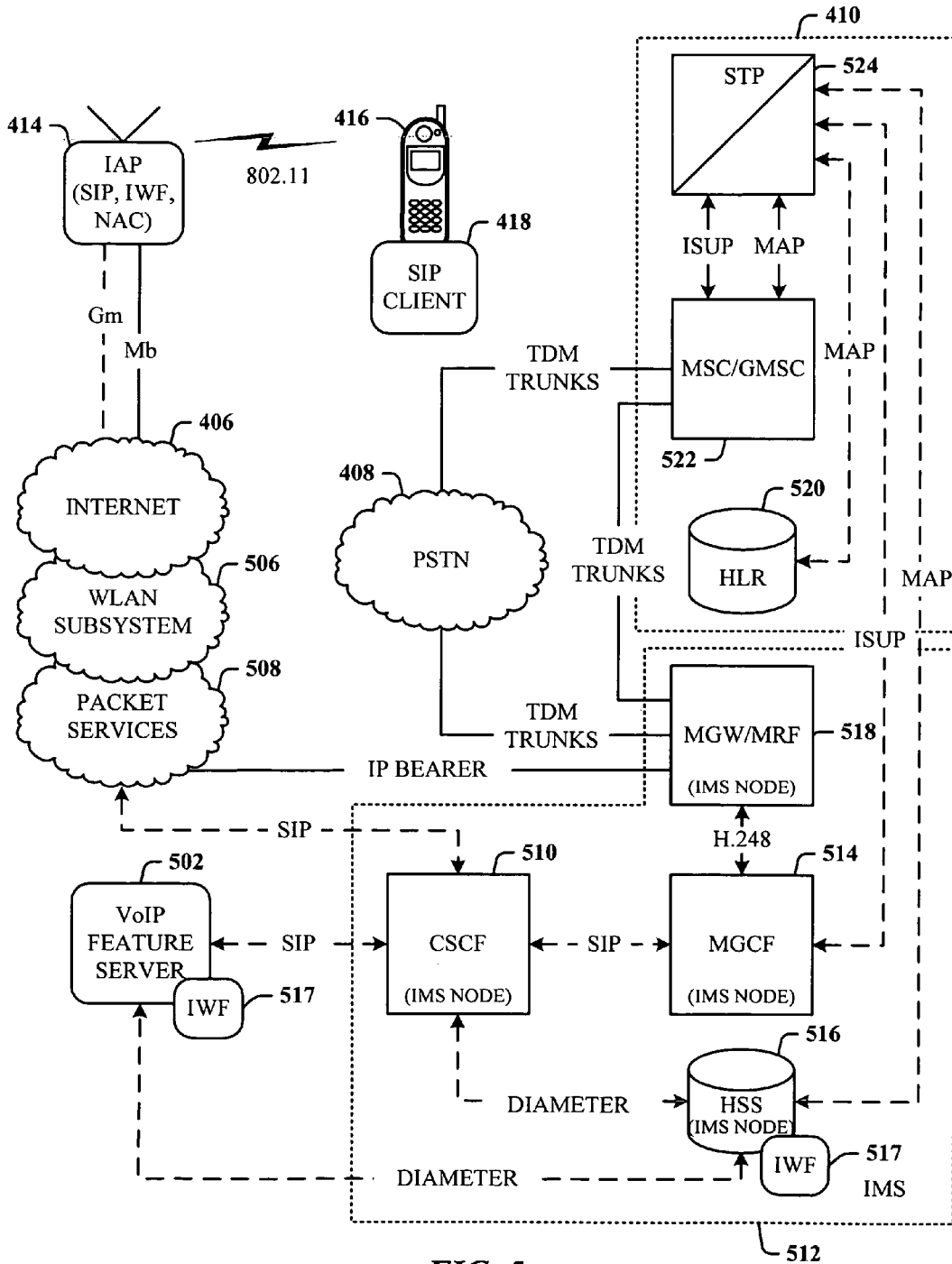

FIG. 5

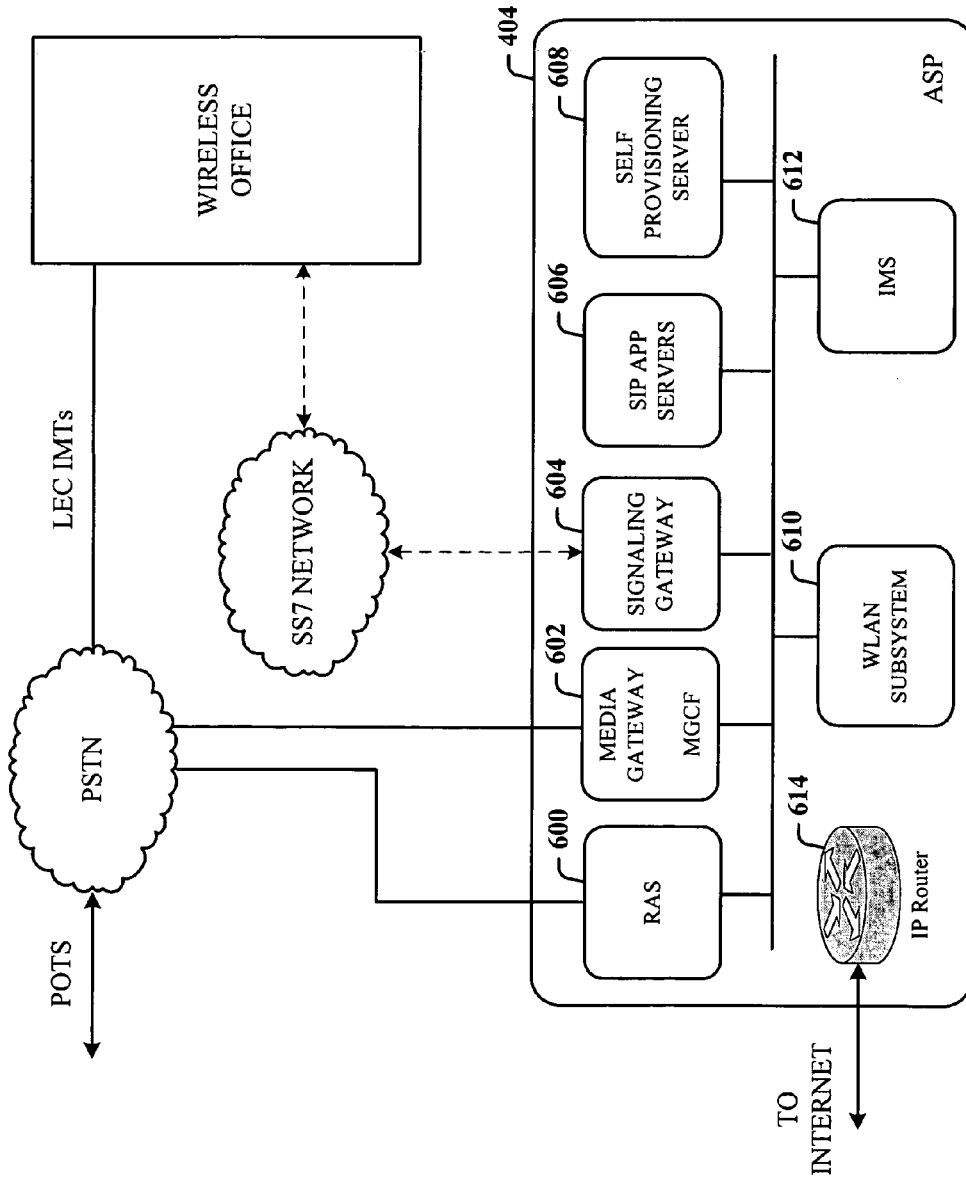

FIG. 6

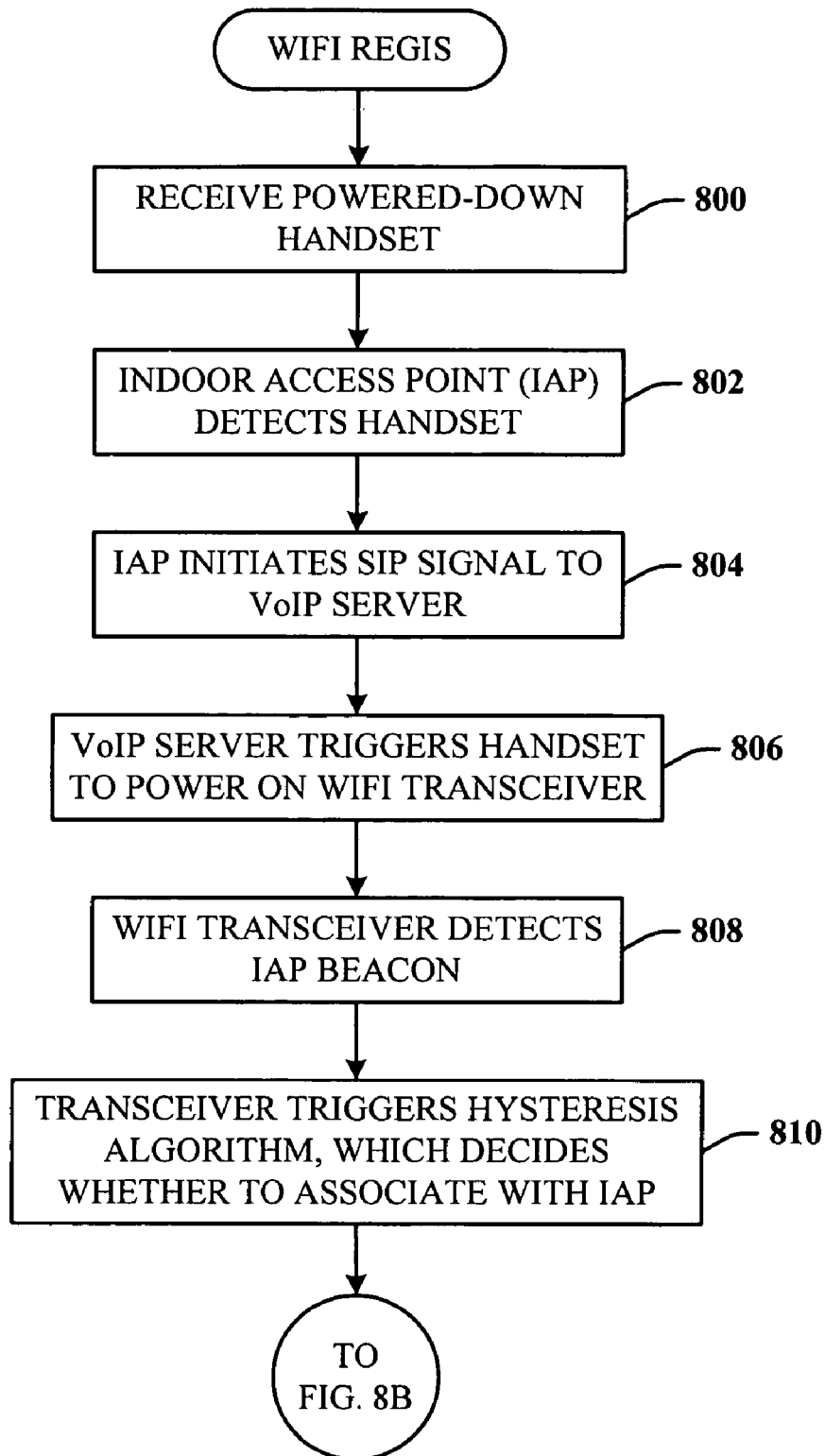

FIG. 8A

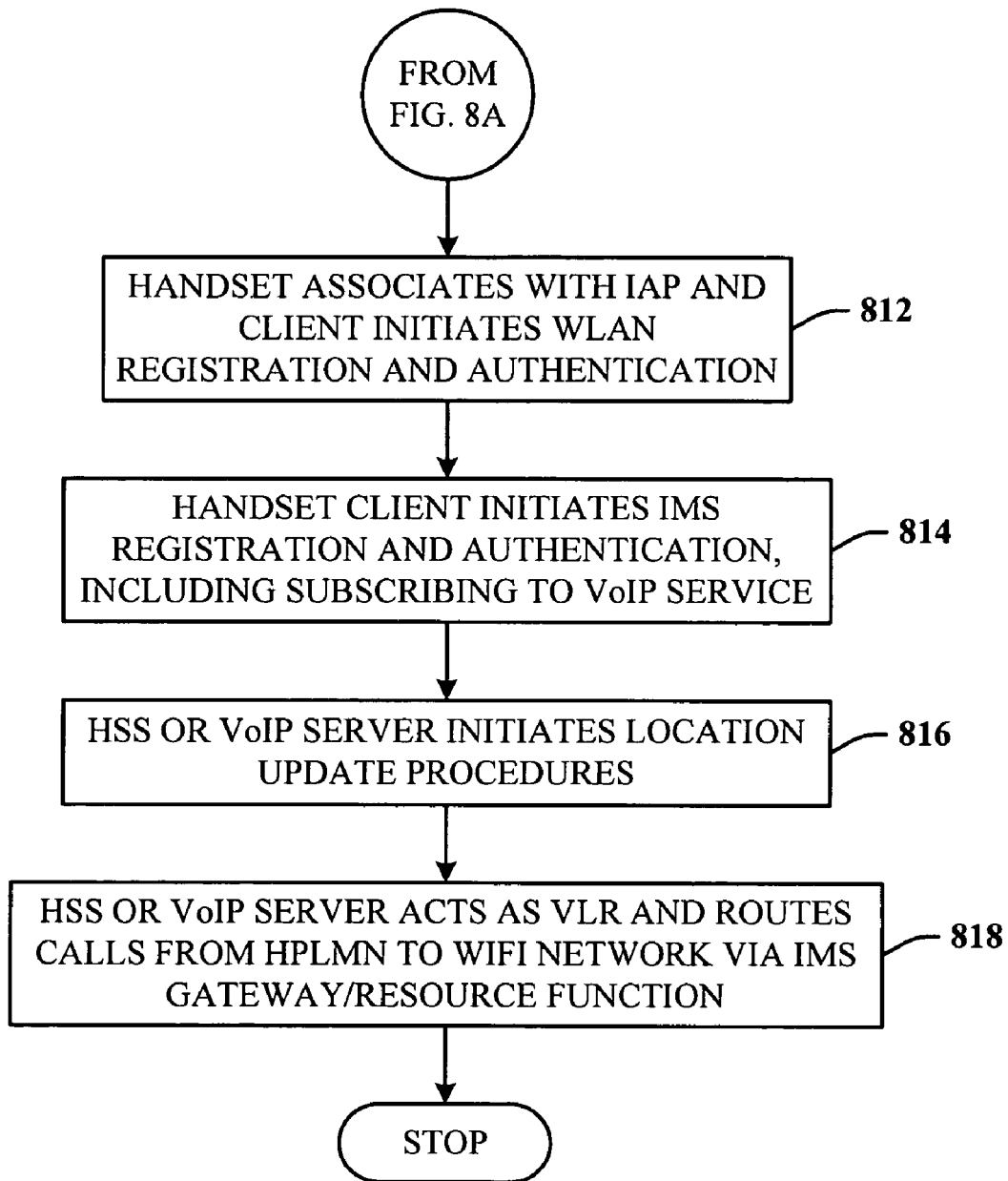

FIG. 8B

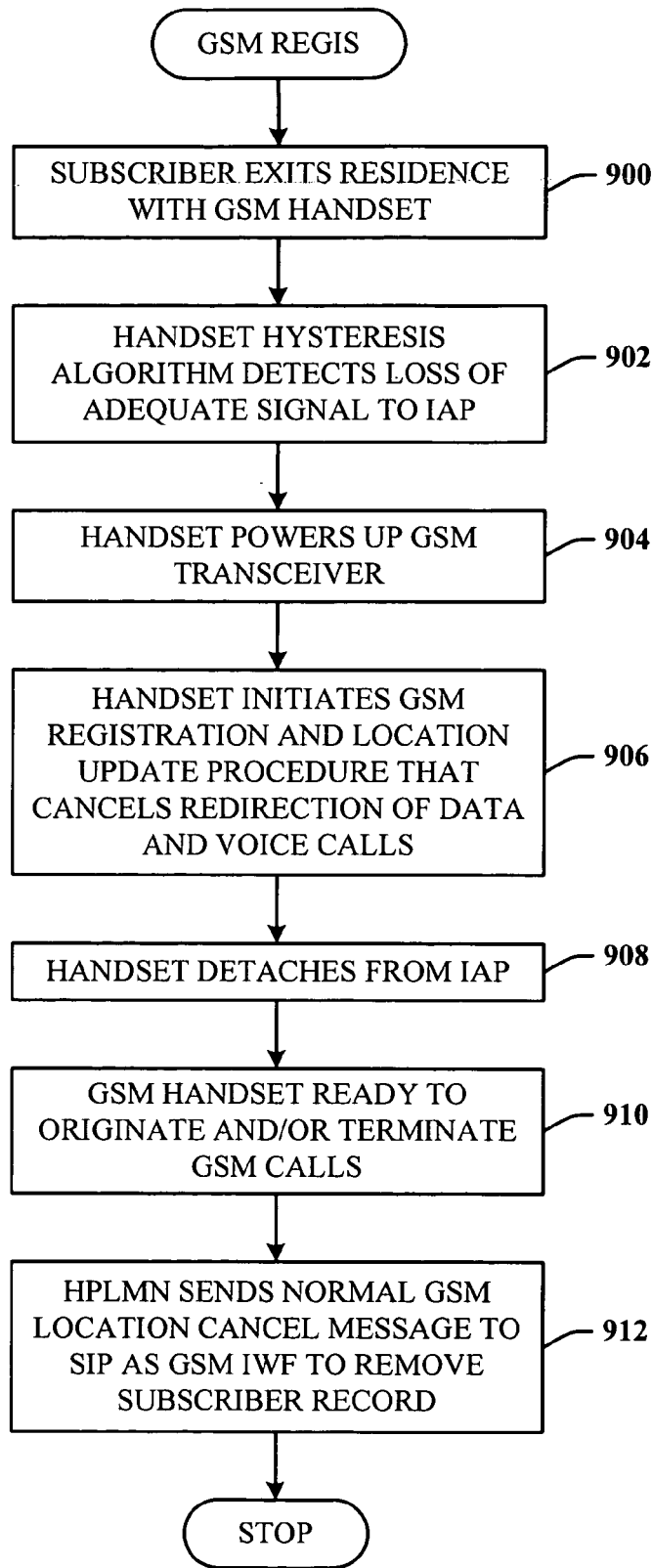

FIG. 9

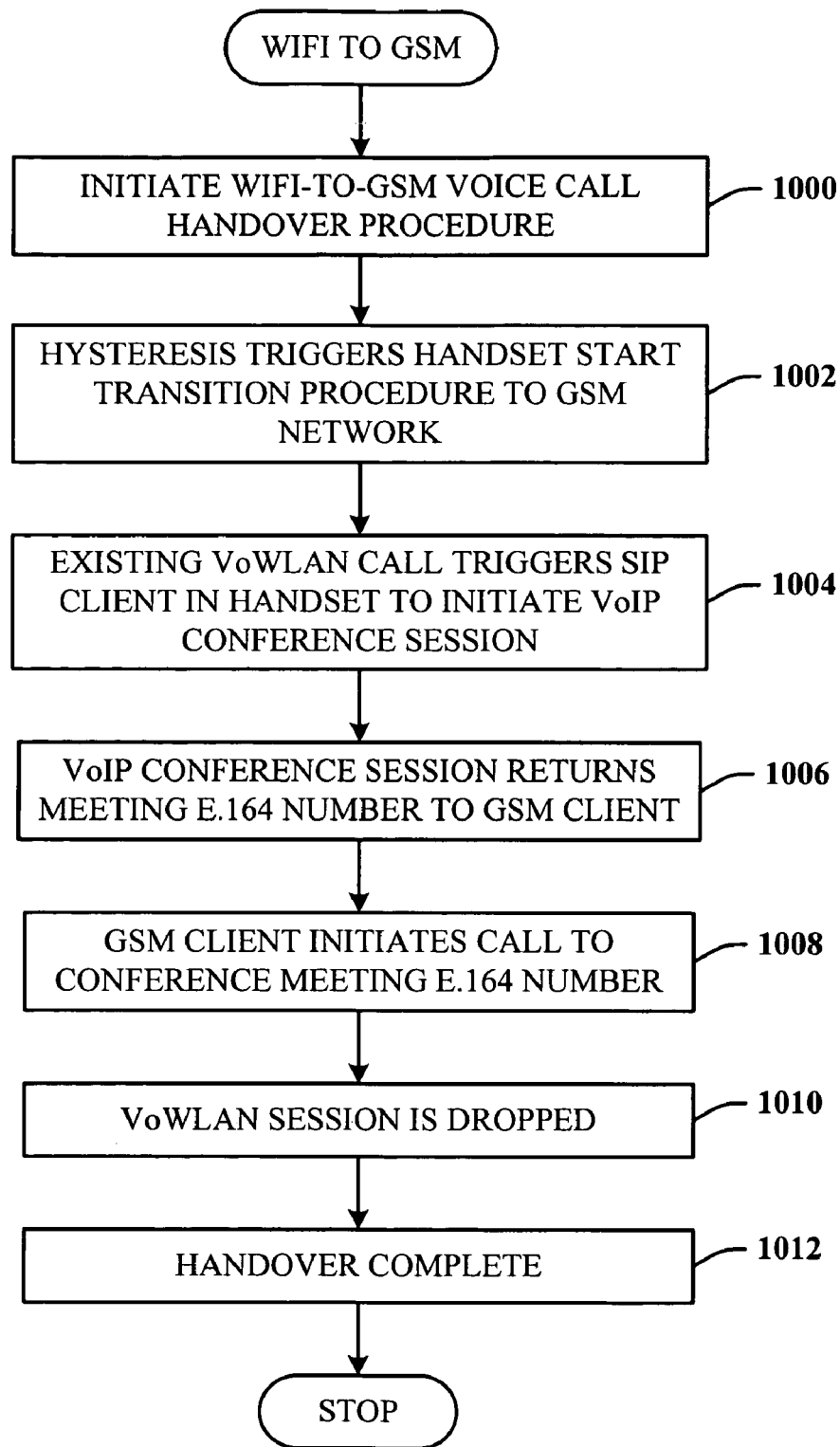

FIG. 10

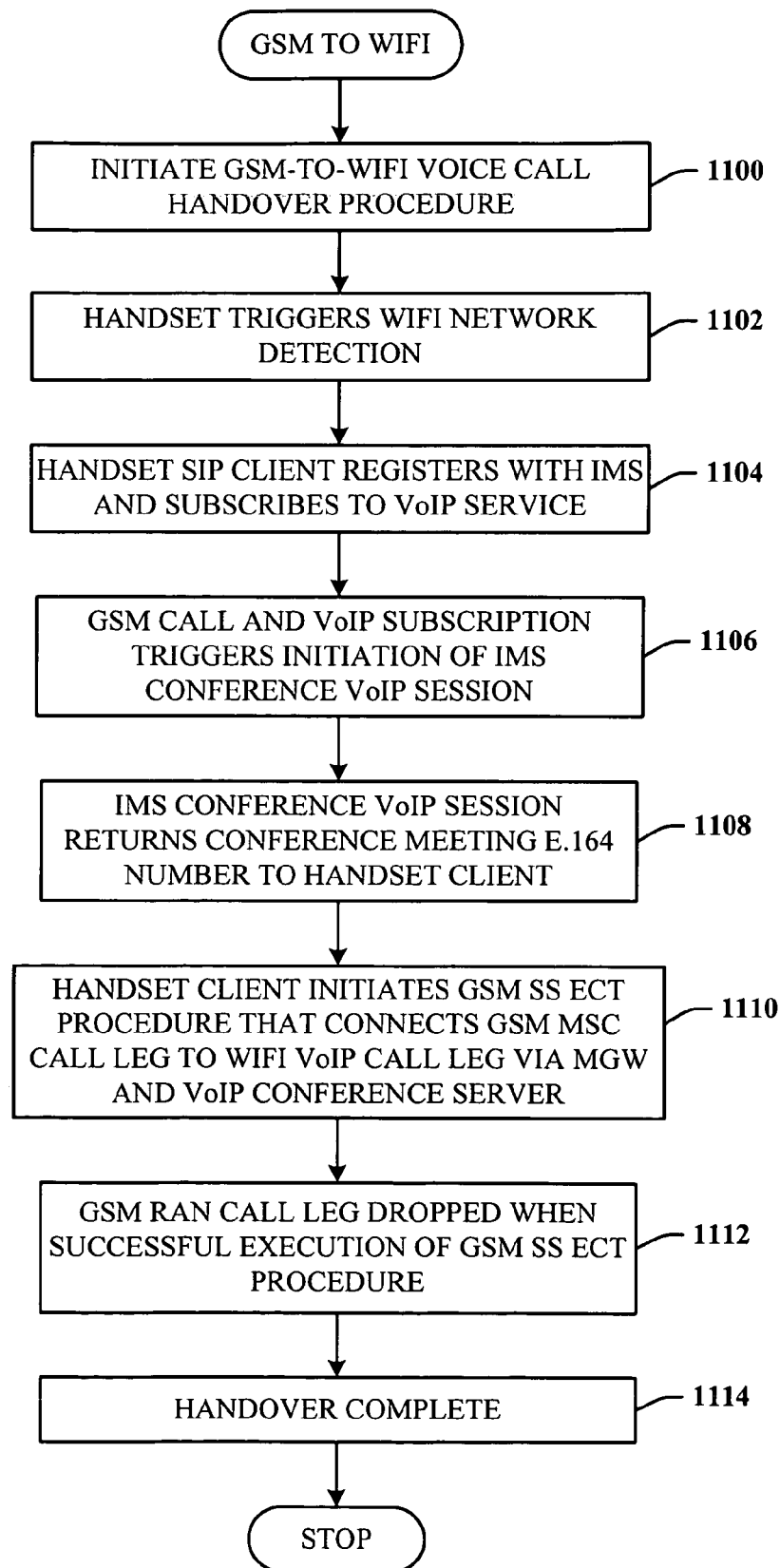

FIG. 11

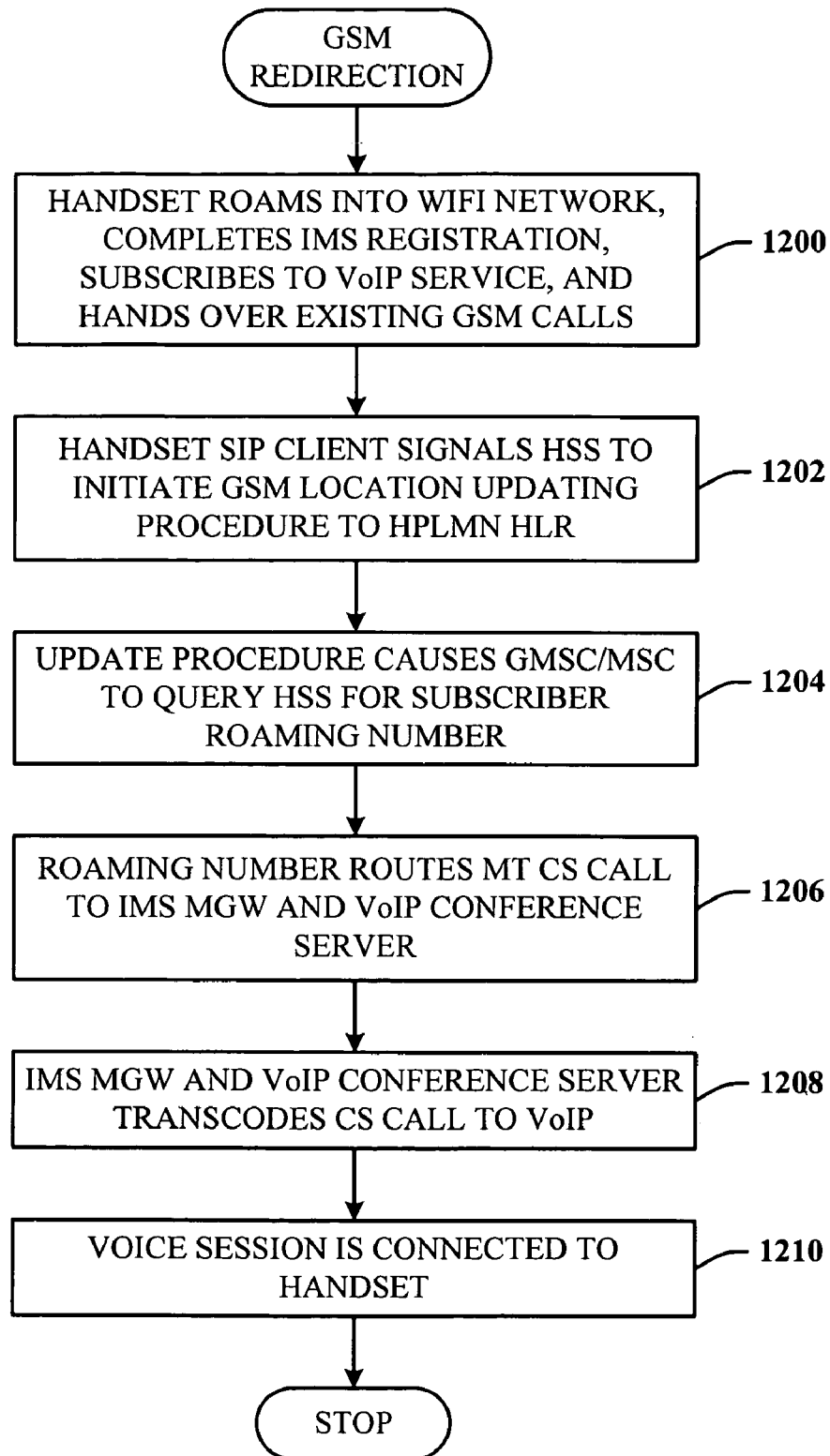

FIG. 12

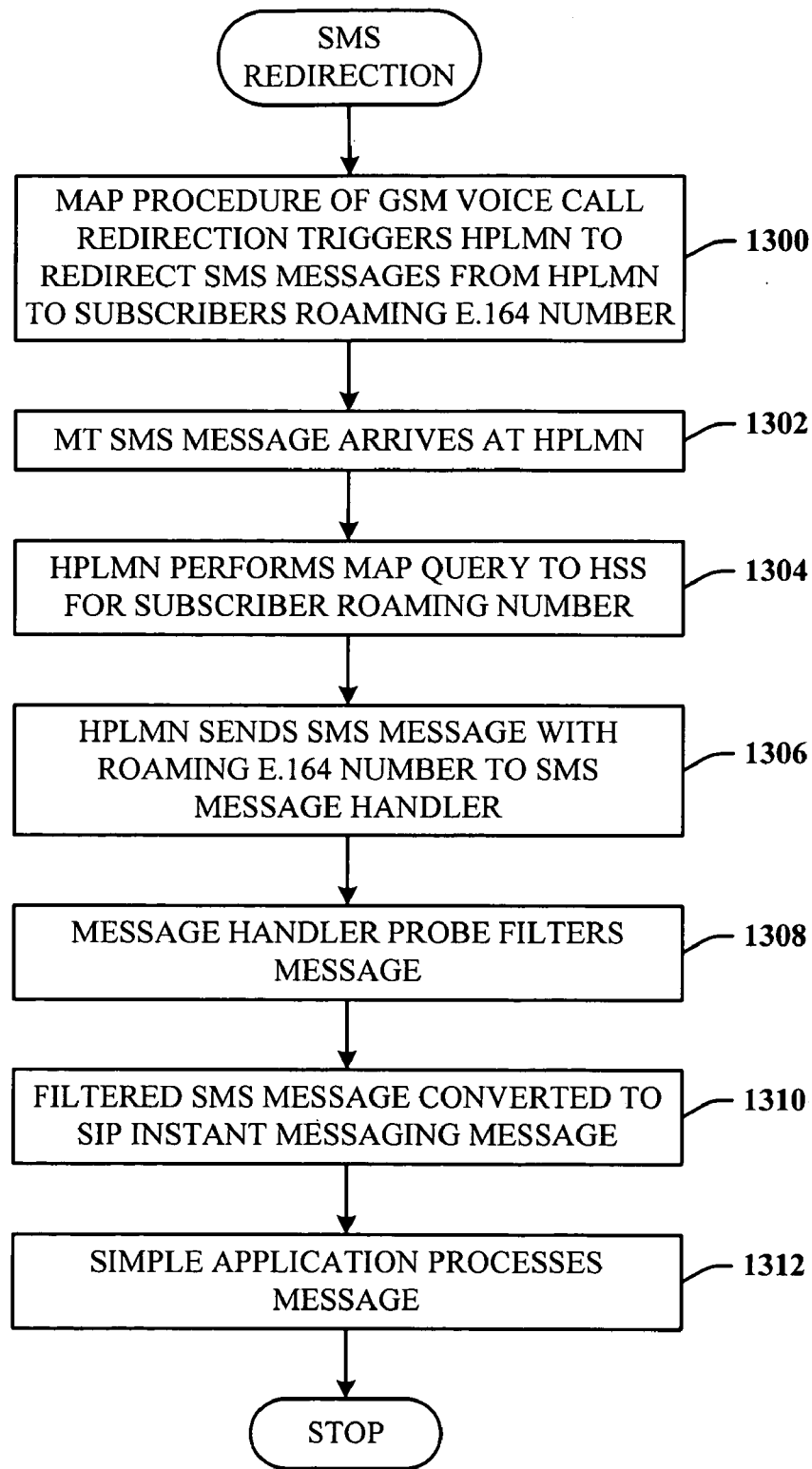

FIG. 13

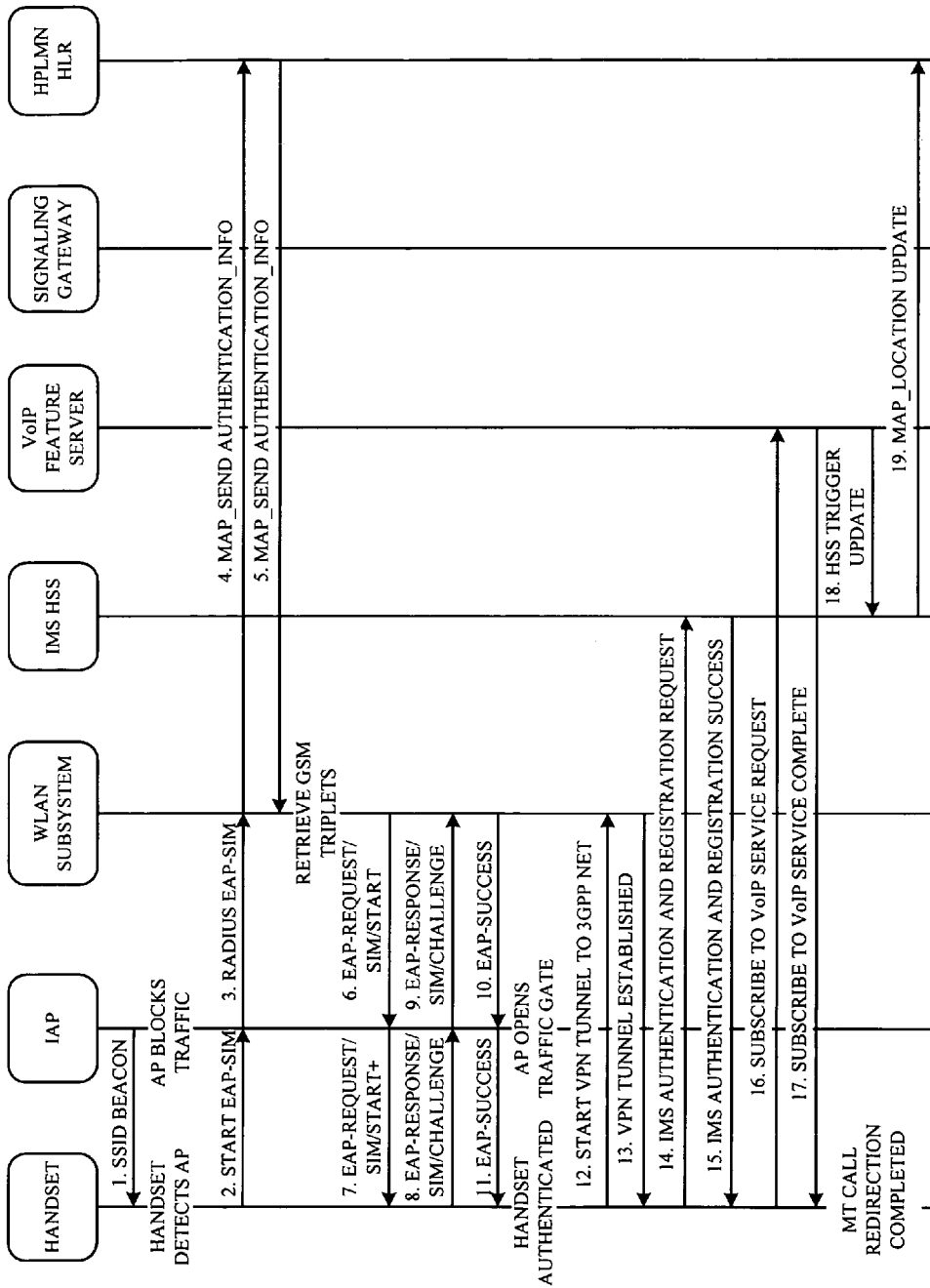

FIG. 14

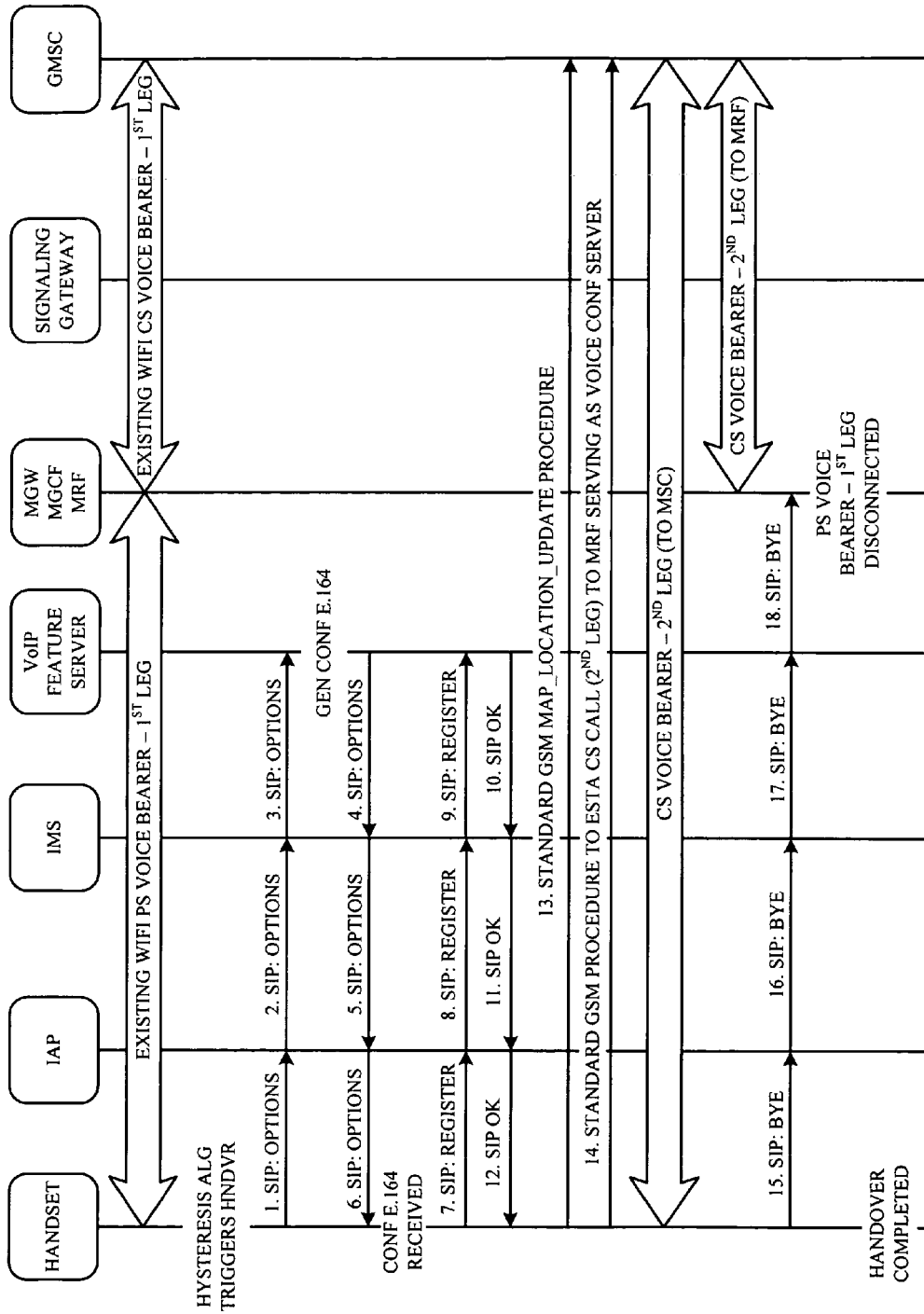

FIG. 15

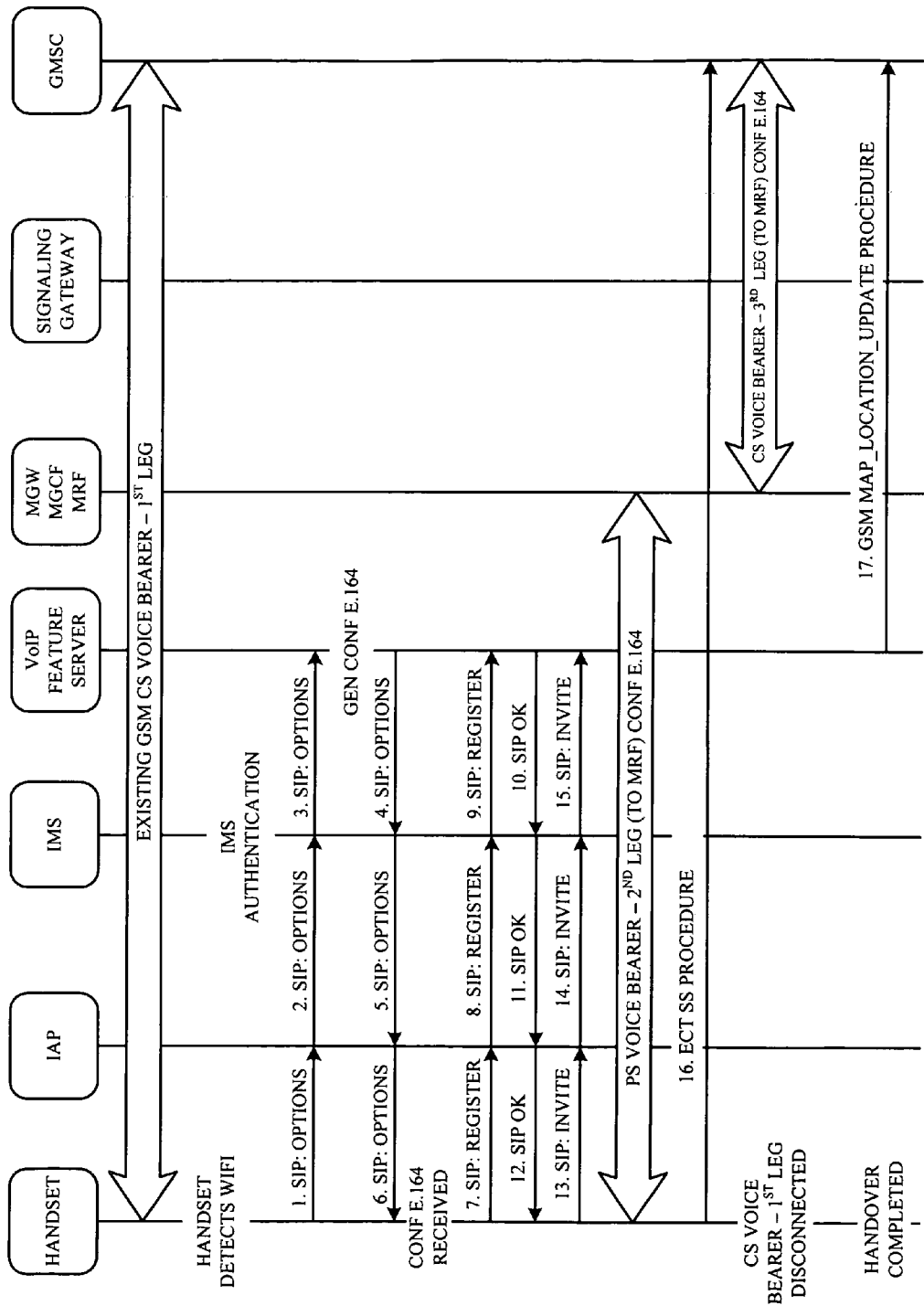

FIG. 16

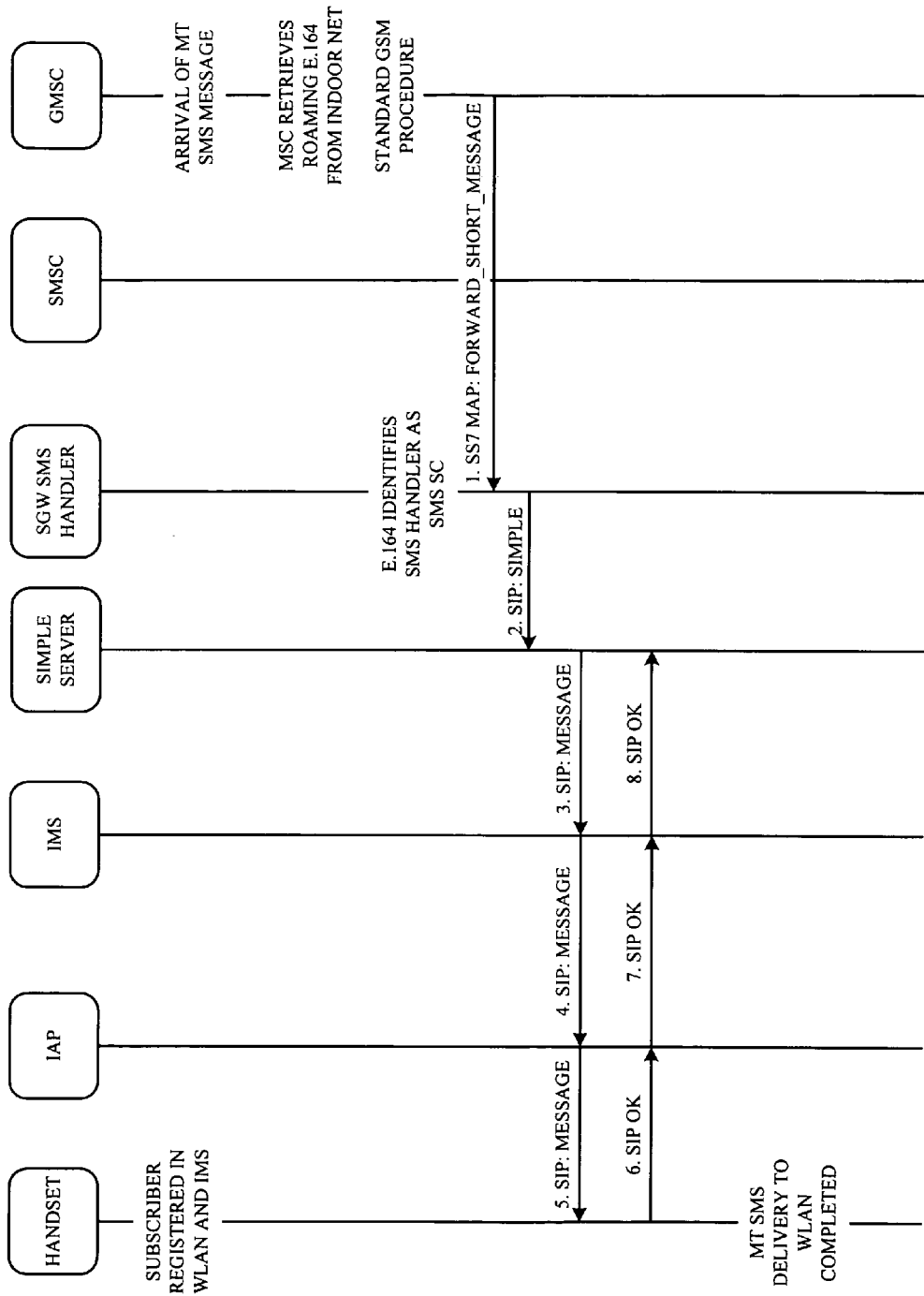

FIG. 17

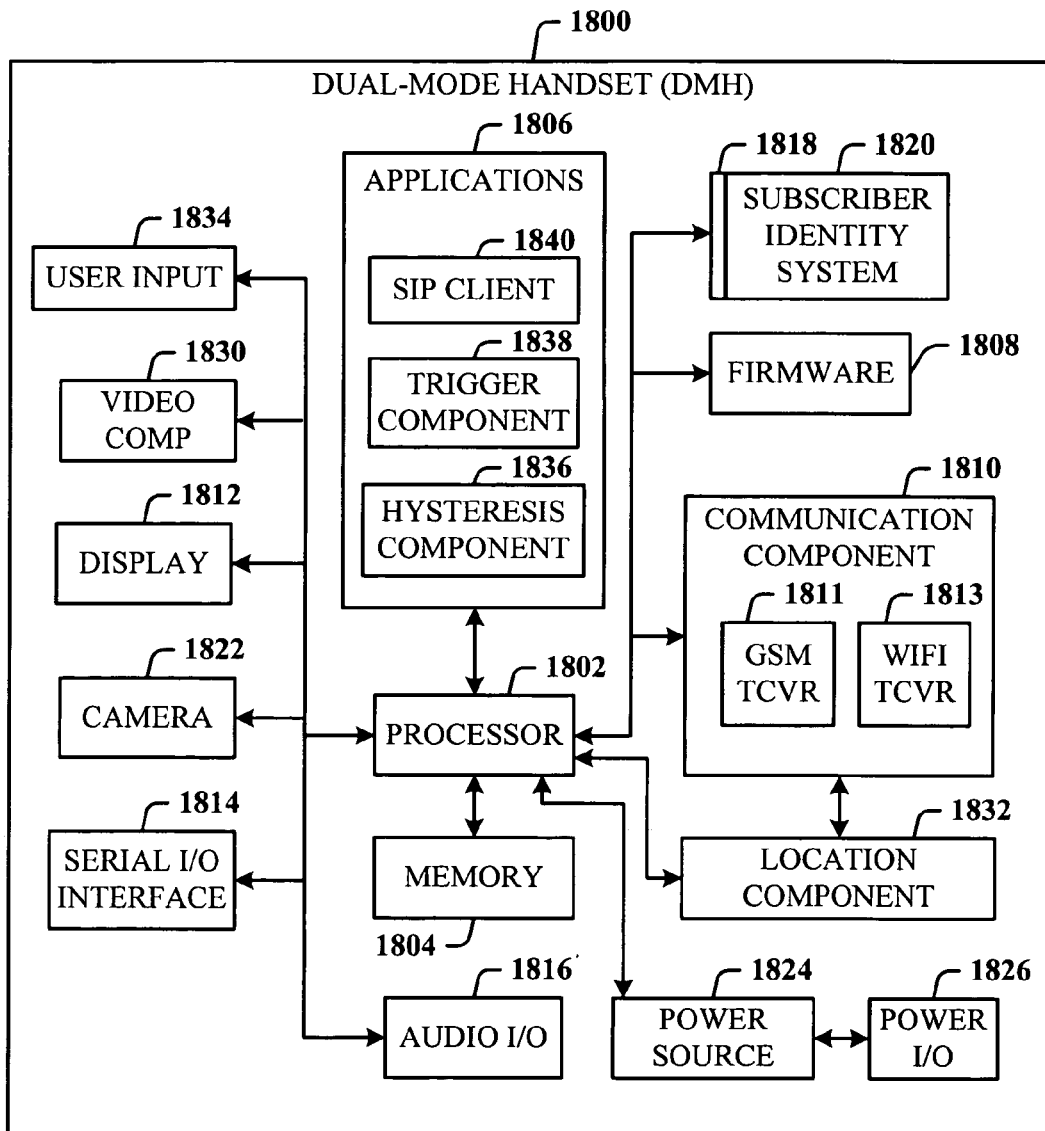

FIG. 18

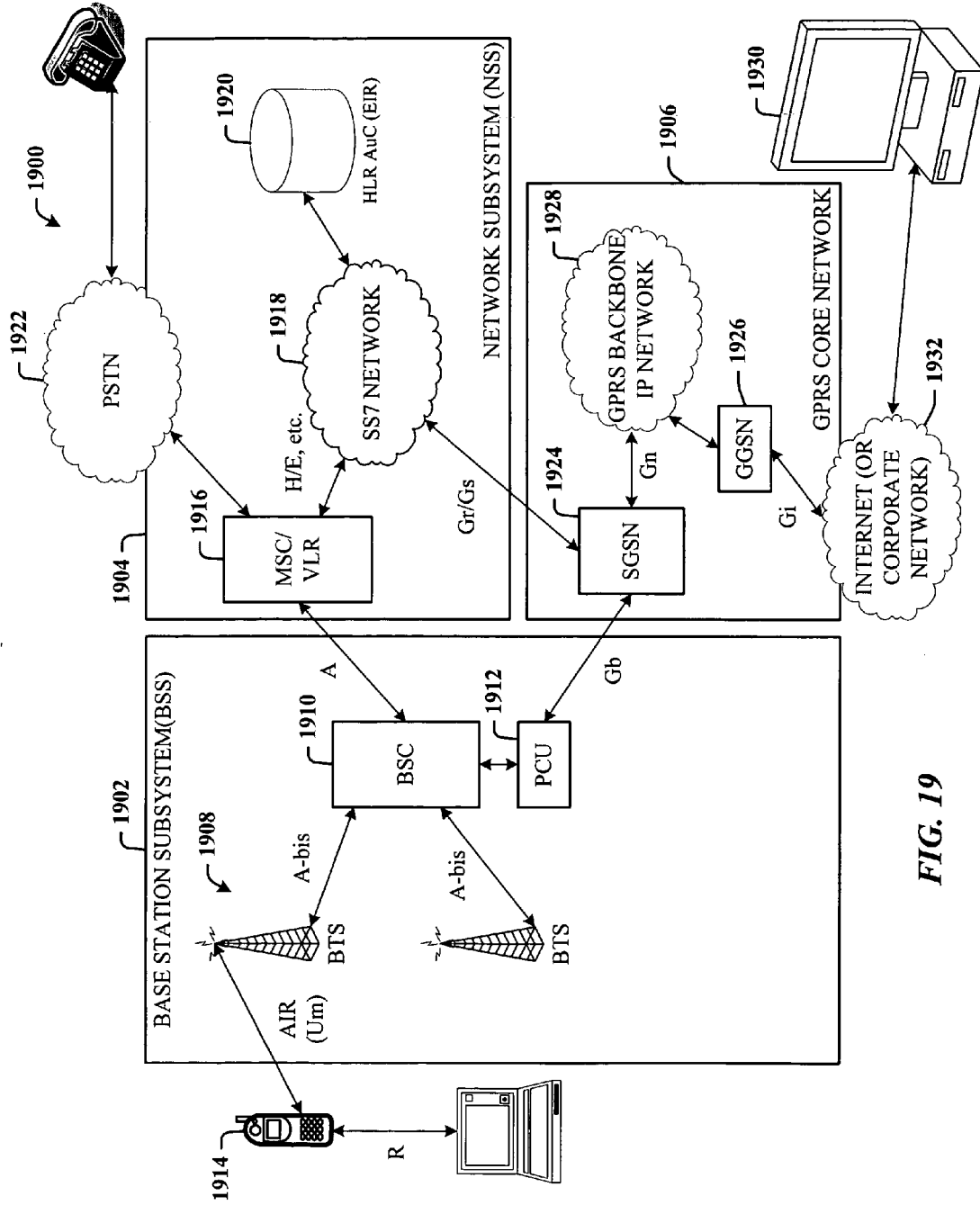

FIG. 19

MULTI-MODE HANDSET SERVICES

TECHNICAL FIELD

[0001] This invention relates to a wireless telecommunications system, and more specifically, to the delivery of dual-mode WiFi/GSM voice and data services to a consumer.

BACKGROUND

[0002] In recent years, the vast majority of the industrialized world has become accessible via the public switched telephone network (PSTN). Most commonly, this accessibility has been implemented through conventional telephone systems. A conventional telephone system may be considered to be and is hereinafter included in the general category of wire-line systems, that is, telecommunications systems that transmit communications over lines such as copper, cable, and/or fiber optic lines. Thus, a unit that operates in a wire-line system can be referred to as a wire-line unit. For example, corded and cordless telephones are common examples of wire-line units.

[0003] Wireless network operators and wire-line affiliates are searching for ways to bundle their wireless and wire-line services under a single pricing plan. One scenario would allow the subscriber to use the same "bucket" of wireless minutes on his/her residential wire-line phone.

[0004] The popularity and widespread acceptance of wireless communication systems have brought about the development of systems that work as an adjunct to wireless communication systems and with the PSTN. An example of an adjunct to wireless communication systems is a fixed wireless loop (FWL) system. An FWL system allows a user to effectively convert certain conventional wire-line telephones into extensions of the user's wireless telephone or unit. In particular, the FWL system usually includes a cell phone physically connected to one or more conventional telephones within a discrete location, such as a home or office. The FWL system allows the user to make use of the wireless communications system through the connected conventional telephones. These extensions to the cell phone can provide the user with certain advantages. Yet, these FWL systems do not provide the user with access to the PSTN independently of the wireless communication system. Such lack of direct access to the PSTN can be critical in the event that one of the wireless communication links, from and including the cell phone to the wireless communication system, is not functioning properly.

SUMMARY

[0005] The following presents a simplified summary in order to provide a basic understanding of some aspects of the disclosed innovation. This summary is not an extensive overview, and it is not intended to identify key/critical elements or to delineate the scope thereof. Its sole purpose is to present some concepts in a simplified form as a prelude to the more detailed description that is presented later.

[0006] The disclosed innovative architecture addresses shortcomings of the prior solutions mentioned above by providing to a user, who has access to the PSTN (public switched telephone network) and also subscribes to a wireless communications service, a mechanism that transpar-

ently automates activation and deactivation of redirecting mobile telephone calls (e.g., mobile terminated and mobile originated) from a home PLMN (public land mobile network) to the subscriber's residence (or other indoor network) over the POTS (plain old telephone system) and/or broadband connections. Automatic roaming registrations are also performed between IMS (IP multimedia systems) platforms and PLMNs, and automatic unlicensed network (e.g., WiFi) to cellular network (e.g., GSM-global system for mobile communications) call and data handovers are performed transparently to the subscriber.

[0007] Accordingly, there is provided a system that employs a trigger component that receives as an input, a signal which causes the trigger component to output a trigger signal to a redirection component. The redirection component processes a call between a cellular network (e.g., GSM) and a home network. That is, as a user, who is conversing during an active telephone call, moves into a building (e.g., a home or business), the redirection component receives a trigger signal from the trigger component and facilitates redirecting the call from a cellular communications system (e.g., GSM) to a VoIP (voice over IP) system in the building. Conversely, as the user converses and moves from the building to the outside, the redirection component receives a trigger signal from the trigger component and facilitates redirecting the call from the inside VoIP network to the cellular communications system. This occurs transparently to the user.

[0008] In operation, as the subscriber moves the mobile handset into the residence, for example, a client of the handset detects a signal of a WLAN access point. Once detected by the handset, the handset SIP (session initiation protocol-) client initiates a registration procedure over a broadband connection with a WLAN VoIP service located at an application service provider (ASP). However, this connection can also be made over the POTS network to the ASP, if the broadband connection is down or does not exist. The handset SIP client initiates registration with a VoIP application server through the IMS. If the handset does not employ a SIP client, but incorporates an unlicensed wireless technology (e.g., Bluetooth), a cordless telephony profile can be employed such that the home access point becomes a gateway to the VoIP network. Thus, the trigger is the handset making contact with the access point, which triggers the access point to initiate the registration procedure with the SIP VoIP network. This further triggers voice call redirection over the broadband connection. Thus, detection can occur with the mobile handset, or the access point, or both the handset and the access point.

[0009] When the handset moves outside or outside the range of the access point, and gains signal communications with the cellular network, the cellular network (e.g., GSM) initiates a registration process. This triggers the cellular network roaming procedures, and a location update is performed with the home network. The home network sends a location cancellation MAP (mobile application part) signal to the visited network, and the visited network then knows that the subscriber is no longer a member of the visited network.

[0010] The innovation, in one exemplary instance, includes delivery of dual-mode GSM/WiFi voice and data services to the consumer with support for transparent net-

work registrations and handovers between GSM and WiFi. Aspects include transparently and wirelessly automating call redirection procedures. An IMS system based on SIP signaling is employed that enables redirection to work with standardized VoIP services. Moreover, the innovation supports the redirection of calls and data to legacy telephone devices, to GSM handsets via broadband, and to VoIP devices via broadband. An indoor network is treated as a pseudo visitor PLMN (VPLMN) by the home PLMN (HPLMN). This innovation does not require GSM radio coverage in the indoor network.

[0011] This innovation provides a means for automating a process of redirecting subscriber's calls from the GSM network to the subscriber's home network. It can utilize an unlicensed spectrum (e.g., Bluetooth) and/or WLAN access point to provide a beacon signal for triggering. The innovation provides a means of redirecting a VoIP call originally addressed to a GSM phone number to the CFU (call forwarding unconditional) number without routing the call through a GSM gateway MSC (mobile switching center). A new set of network elements based on SIP (session initiation protocol) signaling is introduced that enables this concept to work with VoIP services.

[0012] The innovation provides a mechanism to originate and terminate calls in a residence using any one of a POTS phone, mobile device operating in a cordless telephone mode, and wired VoIP handsets. In each of these, the originating and terminating calls can be controlled and directed by an indoor access point, which can operate in an active or passive mode. The subscriber's mobile number is used as the main number, meaning all mobile terminated calls are first routed to the subscriber's HPLMN and then forwarded to the subscriber's residence across a broadband connection.

[0013] Another aspect of the invention provides a means for signaling and bearer traffic to be routed to and from the subscriber's home via POTS and/or broadband connections.

[0014] Yet another aspect of the invention provides a means to automatically detect the presence or absence of the mobile device in the residence. An indoor access point can contain at least a SIP client, a GSM inter-working function (IWF), a NAC (network access controller) function, an indoor network radio transceiver, a mechanical switch, and a GSM receiver. The SIP client will enable the indoor access point to support SIP protocols and register the subscriber with a SIP registrar server. The GSM IWF enables the indoor access point to support GSM authentication, access control and voice codecs. It is needed when this functionality does not reside on the GSM handset. The mechanical switch enables the IAP to manually control signaling and redirection when the IAP is incapable of automatically detecting the GSM handset. The handset device described herein is provided with a GSM receiver that detects the presence of a GSM network and triggers activation of the WiFi radio operating in the handset. The trigger method may include messaging via the broadband/PSTN connection and the GSM/GPRS network.

[0015] Additionally, disclosed herein is a mechanism of transparently controlling the GSM registration procedure in the HPLMN without any modification to the HPLMN. A signaling method to redirect mobile terminated calls is MAP Location Update messaging.

[0016] In another instance, there is provided transparent control of the GSM CFU procedure in the HPLMN without modification to the HPLMN, using MAP signaling.

[0017] In another aspect, there is disclosed redirection of VoIP calls originally addressed to the mobile device number to the CFU number or temporary number without routing the call through the GSM gateway MSC, also referred to as optimal routing.

[0018] In yet another aspect, a mechanism is provided that automatically redirects calls from the HPLMN to the indoor network without having the mobile handset powered on and continuously in wireless contact with the indoor access point.

[0019] In still another aspect, the innovation provides management of voice call handovers between packet-switched networks and circuit-switched networks.

[0020] In another aspect, there is disclosed establishment of a circuit-switched bearer for a mobile device using SIP signaling through a WiFi network.

[0021] The systems and methods described herein disclose automatically powering on a handset WiFi transceiver and starting the handset WiFi registration procedure.

[0022] To the accomplishment of the foregoing and related ends, certain illustrative aspects of the disclosed innovation are described herein in connection with the following description and the annexed drawings. These aspects are indicative, however, of but a few of the various ways in which the principles disclosed herein can be employed and is intended to include all such aspects and their equivalents. Other advantages and novel features will become apparent from the following detailed description when considered in conjunction with the drawings.

BRIEF DESCRIPTION OF THE DRAWINGS

[0023] **FIG. 1** illustrates a system that employs call redirection in accordance with an innovative aspect.

[0024] **FIG. 2** illustrates a methodology of redirecting a call according to an innovative aspect.

[0025] **FIG. 3** illustrates a methodology of redirecting a call when utilizing a GSM/WiFi configuration.

[0026] **FIG. 4** illustrates a dual-mode network that facilitates call redirection in accordance with another aspect of the innovation.

[0027] **FIG. 5** illustrates an exemplary bearer and signaling architecture that can employ innovative aspects of the disclosed innovation.

[0028] **FIG. 6** illustrates a more detailed diagram of the ASP in accordance with the disclosed innovation.

[0029] **FIG. 7** illustrates a more detailed diagram of entities of the wireless office.

[0030] **FIGS. 8A and 8B** illustrate a methodology of registering a subscriber in a WiFi network.

[0031] **FIG. 9** illustrates a methodology of registering a subscriber in a GSM network.

[0032] **FIG. 10** illustrates a methodology of handing over voice calls from a WiFi network to a GSM network.

[0033] FIG. 11 illustrates a methodology of handing over voice calls from a GSM network to a WiFi network.

[0034] FIG. 12 illustrates a methodology of redirecting a GSM call according to another aspect.

[0035] FIG. 13 illustrates a methodology of redirecting SMS messages from the HPLMN to the roaming E.164 number.

[0036] FIG. 14 illustrates a messaging and signaling flow diagram for WiFi registration.

[0037] FIG. 15 illustrates a messaging and signaling flow diagram for WiFi-to-GSM voice handover.

[0038] FIG. 16 illustrates a messaging and signaling flow diagram for GSM-to-WiFi voice handover.

[0039] FIG. 17 illustrates a message and signaling flow diagram for redirecting an MT SMS message to the WiFi handset.

[0040] FIG. 18 illustrates a schematic block diagram of a dual-mode handset in accordance with an innovative aspect.

[0041] FIG. 19 illustrates an exemplary GSM network that facilitates call redirection according to an innovative aspect.

DETAILED DESCRIPTION

[0042] The innovation is now described with reference to the drawings, wherein like reference numerals are used to refer to like elements throughout. In the following description, for purposes of explanation, numerous specific details are set forth in order to provide a thorough understanding thereof. It may be evident, however, that the innovation can be practiced without these specific details. In other instances, well-known structures and devices are shown in block diagram form in order to facilitate a description thereof.

[0043] As used in this application, the terms “component” and “system” are intended to refer to a computer-related entity, either hardware, a combination of hardware and software, software, or software in execution. For example, a component can be, but is not limited to being, a process running on a processor, a processor, a hard disk drive, multiple storage drives (of optical and/or magnetic storage medium), an object, an executable, a thread of execution, a program, and/or a computer. By way of illustration, both an application running on a server and the server can be a component. One or more components can reside within a process and/or thread of execution, and a component can be localized on one computer and/or distributed between two or more computers.

[0044] Although applicable to any existing or yet to be developed wireless telecommunications network, the aspects of the present invention will be described with reference to the GSM (global system for mobile communications) air interface that uses GPRS (General Packet Radio Service) as an enabling bearer. Examples of other suitable wireless and radio frequency data transmission systems include networks utilizing, Time Division Multiple Access (TDMA), Frequency Division Multiple Access (FDMA), Wideband Code Division Multiple Access (WCDMA), Orthogonal Frequency Division Multiplexing (OFDM), and various other 2.5 and 3G (third generation) and above

wireless communications systems. Examples of other suitable enabling bearers include Universal Mobile Telecommunications System (UMTS), Enhanced Data rates for Global Evolution (EDGE), High Speed Downlink Packet Access (HSDPA), and similar communications protocols.

[0045] The subject innovation provides a number of mobility management features. Firstly, the innovation provides for the automatic and transparent (to the user) redirecting of voice calls between a cellular network and a separate network that services a building (e.g., a residence), using a broadband connection as the backhaul. Secondly, the innovation discloses handover of the voice call between a wireless LAN (WLAN) and the cellular network.

[0046] Described herein, in one exemplary implementation of network call redirection, is network detection in the form of automatic detection of GSM and WLAN networks. Network selection provides automatic and transparent transition between the GSM and WLAN networks. Subscriber registration utilizes a GSM location update procedure that facilitates access to IMS (IP multimedia subsystem) services utilizing WiFi. Call redirection facilitates redirecting voice services from/to a GSM network to/from the WLAN network. Persistent data sessions are provided when transitioning between the GSM and WLAN networks. Voice call handovers include the transition of active calls between the GSM and WLAN networks. SMS (short message service) data services redirection forwards SMS messages, for example, from/to the home SMSC to/from the SGW (signaling gateway) SMS message handler.

[0047] It is within contemplation of the subject innovation that other cellular network technologies (e.g., UMTS, CDMA, . . .) can be employed, and that other data services (e.g., MMS) redirection can also be employed.

[0048] In operation, as the subscriber moves the mobile handset into the residence, for example, a client of the handset detects a signal of a WLAN access point. Once detected by the handset, the handset SIP (session initiation protocol) client initiates a registration procedure over a broadband connection with a WLAN VoIP service located at an application service provider (ASP). However, this connection can also be made over the POTS network to the ASP, if the broadband connection is down or does not exist. The handset SIP client initiates registration with an IMS VoIP application server. If the handset does not employ a SIP client, but incorporates an unlicensed wireless technology (e.g., Bluetooth), a cordless telephony profile can be employed such that the home access point becomes a gateway to the VoIP network. Thus, the trigger is the handset making contact with the access point, which triggers the access point to initiate the registration procedure with the SIP VoIP network. This further triggers voice call redirection over the broadband connection. Thus, detection can occur with the mobile handset, or the access point, or both the handset and the access point.

[0049] When the handset moves outside or outside the range of the access point, and gains signal communications with the cellular network, the cellular network (e.g., GSM) initiates a registration process. This triggers the cellular network roaming procedures, and a location update is performed with the home network. The home network sends a location cancellation MAP (mobile application part) signal

to the visited network, and the visited network then knows that the subscriber is no longer a member of the visited network.

[0050] Referring initially to the drawings, **FIG. 1** illustrates a system **100** that employs call redirection in accordance with an innovative aspect. The system **100** can include a trigger component **102** that receives as an input, a signal which causes the trigger component **102** to output a trigger signal to a redirection component **104**. The redirection component **104** processes a call between a cellular network and a home network. That is, as a user, who is conversing during an active telephone call, moves into a building (e.g., a home or business), the redirection component **104** receives a trigger signal from the trigger component **102** and facilitates redirecting the call from a cellular communications system (e.g., GSM) to a VoIP (voice over IP) system in the building. Conversely, as the user converses, and moves from the building to the outside, the redirection component **104** receives a trigger signal from the trigger component **102** and facilitates redirecting the call from the inside VoIP network to the cellular communications system (e.g., GSM). This occurs transparently to the user.

[0051] In one example, the disclosed innovation can transparently automate the activation and deactivation of redirecting mobile terminated calls from the home PLMN (public land mobile network) or HPLMN to the subscriber residence over the POTS (Plain Old Telephone Service) and/or broadband connections; roaming registrations between IMS platforms and PLMNs; and WiFi-to-GSM voice handovers.

[0052] **FIG. 2** illustrates a methodology of redirecting a call according to an innovative aspect. While, for purposes of simplicity of explanation, the one or more methodologies shown herein, e.g., in the form of a flow chart or flow diagram, are shown and described as a series of acts, it is to be understood and appreciated that the subject innovation is not limited by the order of acts, as some acts may, in accordance therewith, occur in a different order and/or concurrently with other acts from that shown and described herein. For example, those skilled in the art will understand and appreciate that a methodology could alternatively be represented as a series of interrelated states or events, such as in a state diagram. Moreover, not all illustrated acts may be required to implement a methodology in accordance with the innovation.

[0053] At **200**, a call is initiated on a cellular network while the user is outside of a building. At **202**, the caller enters the building while on the call. At **204**, the user handset is detected as being indoors via an indoor access point (IAP) signal, for example. At **206**, handover from the cellular network to the home network is triggered, and occurs transparently to the user. At **208**, the user exits the building. At **210**, handover is triggered from the home network back to the cellular network. Again, this occurs transparently to the user.

[0054] Referring now to **FIG. 3**, there is illustrated a methodology of redirecting a call when utilizing a GSM/WiFi configuration. At **300**, a call is initiated on the cellular network using a dual mode GSM/WiFi handset. At **302**, the user enters a building having an indoor VoIP network, while on the call. At **304**, a WiFi client on the handset interacts with an IAP. At **306**, handover from the GSM network to the

indoor VoIP network is triggered based in part on a beacon of the IAP. At **308**, the user exits the home. At **310**, handover from the home network to the GSM cellular network is triggered due to a loss of signal to the handset WiFi client from the IAP. At **312**, the call is maintained on the GSM network automatically and transparently to the user.

[0055] **FIG. 4** illustrates a dual-mode network **400** that facilitates call redirection in accordance with another aspect of the innovation. The dual mode network **400** can include a residential location **402** that connects to an application service provider (ASP) **404** via a broadband connection over a global communications networks **406** (e.g., the Internet), via a PSTN network **408**, and a wireless office **410** and an SS7 (Signaling System 7) network **412**. The residential location **402** depicts an IAP **414**, a multi-mode handset **416** (e.g., GSM/WiFi) that includes a SIP (session initiation protocol) client **418**, a VoIP telephone **420** and a legacy (e.g., POTS) phone **422**.

[0056] The GSM handset **416**, capable of dual-mode GSM/WiFi operation and including the SIP-enabled client **418**, is optionally employed for registration signaling and to originate and terminate calls. The handset **416** may not include the SIP (or other) software client **418** that enables the device to control signaling and bearer traffic. In this case, the IAP **414** can control the registration signaling, and the GSM handset **416** is not capable of sending or receiving through the IAP **414**. The IAP **414** can operate in a passive or active mode. In an active mode, the IAP **414** can be equipped with the following functionality: a SIP client; GSM IWF (inter-working function); NAC (network access controller) function; an indoor network radio transceiver; a mechanical switch; and a GSM receiver. The GSM IWF/NAC component enables the IAP **414** to support GSM authentication, access control, and voice codecs. It is only needed when this functionality does not reside in the GSM handset. The NAC function includes 802.1x and a RADIUS client that supports EAP-SIM and EAP-AKA (authentication and key agreement). The mechanical switch functions to enable the IAP **414** to manually control signaling and redirection when the IAP **414** is incapable of automatically detecting the handset **426**. The GSM transceiver facilitates detecting the presence of handset **416** operating in the GSM mode and triggers the activation of the WiFi radio in the handset **416**. The trigger method may include messaging via the broadband/PSTN connection and the GSM/GPRS network.

[0057] Generally, the home **402** includes a legacy communications system, which comprises the legacy telephone **422** for making calls over the POTS to the PSTN **408**, and therefrom to the wireless office **410** via local exchange carrier (LEC) intermachine trunks (IMTs). In this implementation, a home wireless/broadband communications system includes the IAP **414** (which connects to the legacy system), the VoIP telephone **420**, the wireless handset **416**, and the broadband connection. The broadband operation facilitates IP connection to the Internet **406**, and therefrom to the ASP **404**. The ASP **404** also connects to the PSTN **408** to provided dial-up service through the POTS when the home network does not support broadband connectivity. The ASP **404** also provides a service that converts cellular (e.g., GSM) circuit-switched (CS) calls to packetized calls that can be used by the home VoIP telephone **420**. The wireless office **410** connects to the ASP **404** via the national SS7

network **412** to provide control signaling between the ASP **404** and the wireless office **410**.

[**0058**] In operation, when the user enters the home **402** with the multi-mode handset **416**, the IAP **414** sends a beacon and the handset **416** detects the IAP **414**. A WiFi transceiver of the handset **416** detects the IAP beacon and associates with the IAP **414**. The WiFi client **418** then initiates WLAN registration and authentication through the IAP **414** to a WLAN subsystem (not shown) of the ASP **404** via the Internet broadband connection. The WLAN subsystem facilitates authentication to an HLR (not shown) of the wireless office **410**. Once the handset registration and authentication is successful, the WiFi handset **416** initiates IMS registration and authentication to an IMS HSS (not shown) of the ASP **404** via the Internet broadband connection. This also includes subscribing to VoIP services of the ASP **404**. This subscription updates the subscriber record in the IMS HSS which triggers an update to the HLR of the wireless office **410**. The ASP **404** then routes mobile calls from the home **402** to the WiFi network. Further details for voice handover and SMS message processing are described infra.

[**0059**] **FIG. 5** illustrates an exemplary bearer and signaling architecture **500** that can employ innovative aspects of the disclosed innovation. If the WiFi transceiver of the handset **416** (e.g., GSM) is powered off and the IAP **414** detects the handset **416**, the IAP **414** initiates a SIP signal to a VoIP feature server **502** to trigger the handset **416** to power on the WiFi transceiver. This procedure assumes the IAP **414** is capable of identifying the handset **416**; otherwise, the IAP **414** will operate in the GSM passive mode. When the handset WiFi transceiver detects an IAP beacon signal **504**, the transceiver triggers a hysteresis algorithm, which decides whether to associate with the IAP **414**. When the handset **416** associates with the IAP **414**, the WiFi handset client initiates WLAN subsystem registration and authentication procedures (e.g., 3GPP-3rd Generation Partnership Project). Next, the WiFi handset client initiates an IMS registration and authentication procedure (e.g., 3GPP) that includes subscribing to the VoIP feature service **502**. Note that the IAP **414** interface to the broadband Internet connection via a Gm reference point, and from there, across a WLAN subsystem network **506**, and a packet services network **508**.

[**0060**] The signaling interface facilitates signal communications to the VoIP feature server **502** via SIP protocol through a CSCF (call session control function) entity **510**. The CSCF entity **510** is an IMS node and provides session control for subscribers accessing services within the IMS **512**. Note that not all entities of the IMS **512** are shown. The IMS **512** also includes an MGCF (media gateway control function) entity **514** that supports the call control function for distributed switching systems. The CSCF entity **510** and the MGCF entity **514** communicate signals via SIP. The IMS **512** also include an HSS (home subscriber server) **516** that facilitates AAA services via a DIAMETER protocol.

[**0061**] The HSS **516** is a master database for the PLMN, and while logically it is viewed as one entity, in practice it will be made up of several physical databases, depending on the number of subscribers and the extent of the services which need to be supported. The HSS **516** can hold variables and identities for the support, establishment and mainte-

nance of calls and sessions made by subscribers. This includes the subscriber's IMSI (international mobile subscriber identity), security variables and location information. The IMSI is a unique identifier allocated to each mobile subscriber in a GSM network. It consists of a Mobile Country Code, a Mobile Network Code and a Mobile Station Identification Number. Either the VoIP feature server **502** or the HSS **516** can employ IWF **517** such that MAP communications can occur. Alternatively, both the VoIP feature server **502** and the HSS **516** can employ the IWF **517**.

[**0062**] As well as the basic HLR (home location register)/AuC (authentication center) functions, the HSS **516** can be enhanced through the use of additional databases and reference points. This enables the network to offer the subscriber advanced services and features by interfacing with service application servers based on CAMEL (Customized Applications for Mobile network Enhanced Logic), OSA (open service access) and SIP. CAMEL is a 3GPP initiative to extend traditional IN (intelligent network) services found in fixed networks into mobile networks. The architecture is similar to that of traditional IN, in that the control functions and switching functions are remote. Unlike the fixed IN environment, in mobile networks, the subscriber may roam into another PLMN, consequently the controlling function must interact with a switching function in a foreign network. CAMEL specifies the agreed information flows that may be passed between these networks.

[**0063**] The DIAMETER protocol is intended to provide a framework for any services which require AAA/policy support across many networks such that access and authentication are achieved. The main functions of DIAMETER are to support mobile IP, accounting, network access and strong security. Note that the VoIP server **502** can also communicate to the HSS **516** using the DIAMETER protocol.

[**0064**] Another IMS node depicted is a MGW (media gateway)/MRF (media resource function) entity **518**. Conferencing within the IMS **512** can be coordinated by an S-CSCF (Serving-Call Session Control Function), in conjunction with an AS (application server) of the ASP **404** of **FIG. 4**. The mixing of the various conference participants' media streams is then performed by the MRF which comprises of a MRFC (media resource function controller) and the MRFP (media resource function processor, neither of which are shown). These are very similar in function to the MGCF **514** and a MGW using H.248 in order to establish suitable IP and, if required, SS7 bearers to support the mixed media streams. In the process, the MRFC controls the media streams established by the MRFP, based on information supplied by the S-CSCF, and the relevant application server. H.248 signalling is passed to the MRFP across an Mp interface (not shown). H.248 is the ITU-T (International Telecommunications Union-Telecommunication Standardization Sector) specified media gateway control protocol. It has been specified in conjunction with the IETF (Internet Engineering Task Force). H.248 employs ASN. 1 (Abstract Syntax Notation 1), whereas the IETF version of MGCP (called MEGACO-Media Gateway Control) employs a text-based version of the protocol. Note that the IMS nodes can be located in and managed by any party.

[**0065**] The HSS **516** or VoIP feature server **502** initiates location update procedures with a HPLMN HLR **520**, as part of the wireless office **410**, and acts as the VPLM VLR

(visitor location register) to route mobile terminated calls from the HPLMN to the WiFi network via the IMS MGW/MRF entity **518**. The wireless office **410** also includes an MSC (mobile switching center)/GMSC (gateway MSC) entity **522** and a signaling transfer point (STP) **524**. The MSC is a telecommunication switch or exchange within a cellular network architecture that is capable of interworking with location databases. A GMSC provides an edge function within a PLMN. It also terminates the PSTN signalling and traffic formats, and converts this to protocols employed in mobile networks. For mobile terminated calls, the GMSC interacts with the HLR **520** to obtain routing information. The STP provides for the transfer of signalling messages from one signaling link to another.

[**0066**] As shown, the IMS HSS entity **516** interfaces signals to the STP **524** via a MAP (mobile application part) protocol. Similarly, the HLR entity **520** of the wireless office **410** interfaces to the STP **524** via MAP, as does the STP **524** to the MSC/GMSC **522**. The MGCF entity **514** of the IMS **512** interfaces to the STP **524** via ISUP (ISDN user part). ISUP is part of the SS7 protocol layer, and is used in the setup, management, and release of trunks that carry voice and data between calling and called parties. The MSC/GMSC entity **522** also interfaces to the STP **524** using ISUP.

[**0067**] The MSC/GMSC entity **522** and MGW/MRF entity **518** exchange bearer traffic directly over TDM (time division multiplex) trunks and over TDM trunks via the PSTN **408**. The MGW/MRF entity **518** communicates IP traffic to the packet services network over an IP bearer.

[**0068**] In the case of automatically detecting the presence or absence of the GSM handset **416** in the indoor network, the location update approach can provide a more reliable solution. This solution does not rely on the indoor network to deactivate call redirection, as is the case with the CFU approach. When the GSM handset **416** loses contact with the indoor network, the GSM network deactivates call redirection to the home network. The handset **416** will power-on the GSM transceiver and initiate a registration and location update with the GSM network. After this procedure is completed, the GSM sends the indoor network a location cancellation message. The GSM handset **416** does not need to maintain contact with the indoor network to keep call redirection active. This approach allows the subscriber to power off the GSM handset **416**. Thus, the handset **416** activates the call redirection process and the GSM network deactivates the call redirection process. This does not require that the GSM network activate the redirection process.

[**0069**] The local wireline network and/or ASP **404** of **FIG. 4** can use AIN (advanced intelligent networking) capabilities and CAMEL to implement optimal routing whenever the subscriber is registered in the indoor network. Further, the wireline network can use caching with AIN capabilities and/or SIP signaling to optimize call signaling for mobile terminated calls. This method implies the use of E.164 and ENUM between the PSTN and HPLMN. E.164 is the format of global switched telephone numbers are defined by the ITU-T E164 standard. The 16-digit number is split into international, national and user number portions (e.g., +44(0) 1189 497094). ENUM is an IETF proposal in which DNS (domain name server) systems can be used to translate E.164 telephone numbers into URL (uniform resource locator) and IP addresses.

[**0070**] For PSTN-to-mobile terminated calls, the PSTN uses ENUM to lookup the SIP URL for the public E.164 number and queries the SIP subscriber and/or presence service for availability to route the call directly to the SIP URL or the temporary E.164 number.

[**0071**] With respect to emergency services (e.g., E911 services) over WiFi, physical location and integrity can be addressed. Location can be provided to a PSAP (public safety answering point) using street address of the broadband access point. The customer can be required to enter the street address of the broadband access point into a web form during subscription, or during a change of address. The PSAP is a physical location where 9-1-1 emergency telephone calls are received and then routed to the proper emergency services. Integrity of the location information can be based on a pseudo-honor system. The VoIP service can detect a change in the status of the broadband access point and force the subscriber to re-enter the emergency services location information. The subscriber can also be legally bound to comply with the dual-mode emergency services requirements or choose not to subscribe to emergency services.

[**0072**] Referring now to **FIG. 6**, there is illustrated a more detailed diagram of the ASP **404** in accordance with the disclosed innovation. The ASP **404** includes a remote access service (RAS) **600** that supports dial-up services through the POTS when the indoor network does not support broadband connectivity. A media gateway **602** employs a media gateway control function (MGCF) to facilitate mediating or converting GSM circuit-switched calls to packetized voice calls that can be used by VoIP devices. The MGCF controls the parts of the call state that pertain to connection control for media channels in the media gateway. A signaling gateway **604** converts a SIGTRAN formatted signaling message to a legacy SS7 signaling message transported over TDM circuits and includes an SMS message handler for routing SMS messages between the HPLMN and the indoor network.

[**0073**] A SIP application server **606** consists of several logical services. A SIP registrar component serves as the main VoIP subscription register (or database) where the other network elements query to get information on the subscriber such as is the subscriber active and receiving calls on the Indoor Network, for example. A GSM IWF component supports GSM authentication, access control, and MAP signaling. It provides logic to handle GSM registrations; CFU (call forwarding unconditional) activation and deactivation, location updates, and location cancel messages. A GSM VLR acts as a standard GSM VLR to receive subscriber information from the HLR. It triggers subscriber updates in the SIP registrar. A SIP DNS acts as a standard DNS server with support for E.164 and SIP name addressing. A VoIP Feature Server component provides voice communications call control and processing based on SIP signaling.

[**0074**] The ASP **404** also includes a self-provisioning server **608** that provides a web services interface and/or Internet portal that enables an ASP or individual subscriber to self-provision and manage services. A WLAN subsystem **610** (e.g., 3GPP) (similar to WLAN subsystem **506**) consists of a packet data gateway (e.g., a VPN-virtual private network server) and an AAA (access, authorization and

accounting) server (e.g., 3GPP) that enables the subscriber to use WiFi access as a bearer to packet services (e.g., 3GPP). An IMS entity **612** (similar to IMS entity **512**) consists of a group of network elements that enable the service delivery of SIP-based applications, such as VoIP. An IP router **614** facilitates routing IP traffic between the ASP **404** and the Internet.

[**0075**] **FIG. 7** illustrates a more detailed diagram of entities of the wireless office **410** of **FIG. 4**. An HLR **700** (similar to HLR **520** of **FIG. 5**) is provided which is an SS7 database employed in cellular networks. The HLR **700** interfaces to an STP **702** (similar to STP **524** of **FIG. 5**) via MAP as part of the SS7 protocol. MAP standards address registration of carriers and intersystem handoff procedures. The STP **702** interfaces to the national SS7 network **412** for signal communications to the ASP **404**. The wireless office **410** can also include an MSC/GMSC **704** (similar to MSC/GMSC **522** of **FIG. 5**) that interfaces to the HLR **700** via MAP, and to the PSTN **408** via the LEC IMTs. The GMSC is a means to route a mobile station call to the MSC that contains the called party HLR.

[**0076**] **FIGS. 8A and 8B** illustrate a methodology of registering a subscriber in a WiFi network. If the WiFi transceiver of the handset is powered off and the IAP detects the handset, the IAP can initiate a SIP signal to the VoIP server to trigger the handset to power on the WiFi transceiver. The methodology assumes the IAP is capable of identifying the GSM handset; otherwise, the IAP will operate in the GSM passive mode. Beginning with **FIG. 8A**, at **800**, the handset is received in a power-down mode. At **802**, the IAP detects the handset. At **804**, the IAP initiates a SIP signal to a VoIP server. At **806**, the VoIP server triggers the handset to power on its WiFi transceiver. At **808**, when the WiFi transceiver detects the IAP beacon signal, the transceiver triggers a hysteresis algorithm which decides whether to associate with the IAP, as indicated at **810**.

[**0077**] Continuing with **FIG. 8B**, the handset associates with the IAP and the handset client initiates WLAN (e.g., 3GPP) registration and authentication, as indicated at **812**. At **814**, the WiFi handset client initiates the IMS registration and authentication procedures (e.g., 3GPP) that include subscribing to the VoIP service. At **816**, an HSS (home subscriber server) or VoIP feature server initiates location update procedures. The update procedures are initiated with the HPLMN HLR, and the HSS or VoIP feature server acts as the visitor PLMN (VPLMN) VLR to route mobile terminated calls from the HPLMN to the WiFi network via the IMS media gateway/media resource function, as indicated at **818**.

[**0078**] **FIG. 9** illustrates a methodology of registering a subscriber in a GSM network. At **900**, the subscriber (or mobile user) exits the residence with the GSM handset. At **902**, the hysteresis component in the handset detects that the IAP received signal strength falls below a predetermined acceptable level. Once this happens, at **904**, the GSM transceiver is powered-up, and GSM registration occurs, at **906**. The GSM handset initiates a normal GSM registration and location update procedure that cancels the redirection of data and voice calls. After registration, the handset detaches from the IAP, as indicated at **908**. At **910**, the GSM handset is ready to originate and terminate calls over the GSM network. At **912**, the HPLMN sends a normal GSM Location

Cancel message to the SIP application server GSM IWF to remove the subscriber record.

[**0079**] **FIG. 10** illustrates a methodology of handing over voice calls from a WiFi network to a GSM network. At **1000**, the user exists a building, and the WiFi-to-GSM voice call handover procedure is initiated. At **1002**, the hysteresis algorithm of the handset triggers the handset to start the transition procedure to the GSM network. At **1004**, the existing VoWLAN (voice over WLAN) call triggers the SIP client in the handset to initiate a VoIP conference session. At **1006**, a VoIP conference session returns a conference meeting E.164 number to the GSM handset client. At **1008**, the GSM handset client initiates a call to the conference meeting E.164 number. At **1010**, the VoWLAN voice session is dropped, and the handover is completed, as indicated at **1012**.

[**0080**] **FIG. 11** illustrates a methodology of handing over voice calls from a GSM network to a WiFi network. At **1100**, subscriber enters a building and the WiFi-to-GSM network handover is initiated. At **1102**, WiFi network detection is triggered on the handset. At **1104**, the handset SIP client registers with IMS and subscribes to the VoIP service. At **1106**, the existing GSM voice call and VoIP subscription triggers the SIP client on the handset to initiate an IMS conference VoIP session. At **1108**, the IMS conference VoIP session returns a conference meeting E.164 number to the GSM handset client. At **1110**, the GSM handset client initiates a GSM SS (supplementary services) ECT (explicit call transfer) procedure to connect the GSM MSC call leg to the WiFi VoIP call leg via the MGW and VoIP conference server. At **1112**, successful execution of the GSM SS ECT procedure triggers the GSM RAN (radio access network) call leg to drop. At **1114**, the handover is completed.

[**0081**] **FIG. 12** illustrates a methodology of redirecting a GSM call according to another aspect. This methodology assumes the HSS provides VPLMN VLR functionality and interconnects with the HPLMN GMSC/MSC using the C and D interfaces. The feature is activated when the dual-mode handset roams into the WiFi network and is used to redirect GSM mobile terminated call from the GSM network to the WiFi network. At **1200**, the dual-mode handset roams into the WiFi network and completes the IMS registration, subscribes to VoIP service, and hands over any existing GSM calls. At **1202**, the SIP client on the handset signals the HSS to initiate a GSM location updating procedure to the HPLMN HLR. At **1204**, the GSM location updating procedure causes the HPLMN GMSC/MSC to query the HSS to the dual-mode subscriber's roaming number. At **1206**, the dual mode subscriber's roaming number routes the mobile terminated CS call to the IMS MGW and VoIP conference server. At **1208**, the IMS MGW and VoIP conference server transcodes the CS call to VoIP. At **1210**, the IMS MGW and VoIP conference server connects the voice session the handset. Note that in one implementation, mobile originated SMS messages can follow the reverse path of mobile terminated SMS messages. In another implementation, mobile originated SMS messages do not follow the reverse path of mobile terminated SMS messages.

[**0082**] **FIG. 13** illustrates a methodology of redirecting SMS messages from the HPLMN to a roaming E.164 number. At **1300**, the GSM Locating Update MAP procedure performed in GSM Voice Call Redirection triggers the

HPLMN to redirect SMS messages from the HPLMN to the subscriber's roaming E.164 number via SS7. At **1302**, a mobile terminated SMS message arrives at the HPLMN. At **1304**, when the mobile terminated SMS message arrives, the HPLMN performs a MAP query to the HSS to obtain the subscriber's roaming number. At **1306**, the HPLMN sends the SMS message via SS7 and addressed to the roaming E.164 number to the SGW/SMS Message Handler. At **1308**, the SGW/SMS Message Handler's SS7 probe filters the SS7 message that contains the subscriber's SMS message. At **1310**, the filtered SMS message is converted to SIP instant messaging message. At **1312**, the filtered SMS message is processed by a SIMPLE application.

[0083] There can be at least two bearer methods for SMS. One is the standard use of the existing voice path control channel or one of the control channels such that the caller can receive voice and SMS messages at the same time. Another method is to receive SMS over GPRS. Thus, there can be different procedures for redirecting SMS messages, depending on the bearer mechanism.

[0084] **FIGS. 14-17** illustrate signal flow diagrams of one or more aspects of the innovative redirection architecture. Note that for simplicity, not all signal procedures are shown and some procedures may be simplified.

[0085] **FIG. 14** illustrates a messaging and signaling flow diagram for WiFi registration. The procedural flow is described as follows. Initially, when the user brings the handset into range, the WiFi IAP broadcasts an SSID (service set identifier) signal within the indoor network. The SSID or network name is used within IEEE 802.11 networks to identify a particular network. It is usually set by the administrator setting up the WLAN and will be unique. The SSID may be broadcast from the IAP within the wireless network to enable handsets to determine to which network to associate.

[0086] In another scenario, the IAP does not broadcast the SSID, but the handset is capable of detecting the IEEE 802.11 association, and this will be the trigger. In either case of where the SSID is broadcast or not broadcast, once the handset is able to access an authorized IAP, this can be a trigger for the redirection process.

[0087] The handset then detects the IAP signal. The handset WiFi client starts an 802.1x EAP-SIM (Extensible Authentication Protocol-Subscriber Identity Module) authentication procedure. The IAP blocks all non-authentication packets coming from the handset. The WiFi IAP NAC function serves as a radius client that communicates with a 3GPP WLAN Subsystem (e.g., 3GPP AAA Server) and exchanges SIM credentials. The 3GPP WLAN Subsystem queries the HPLMN HLR via a MAP_SEND AUTHENTICATION_INFO message to retrieve the GSM triplets used in the SIM authentication procedure. The HPLMN HLR returns the GSM triplets in an SS7 MAP_SEND AUTHENTICATION_INFO message. The 3GPP WLAN Subsystem retrieves the GSM triplets from the MAP message.

[0088] The 3GPP WLAN Subsystem starts the EAP-SIM procedure with the handset. The handset runs a GSM authentication algorithm on the GSM triplets and returns challenge response to the WLAN Subsystem. The WLAN Subsystem validates the challenge response and returns an EAP-Success message to the WiFi access point indicating

success authentication of the handset. The WiFi access point returns the EAP-Success message to the handset. The WiFi network access authentication process is then complete. The WiFi access point opens the traffic gate and allows the handset to send and receive all packets. WLAN Subsystem tunneling procedures are initiated and completed. 3GPP IMS registration procedures using SIM are then initiated and completed. The handset sends a SIP Subscribe message to the VoIP Feature Server to access VoWLAN services. The VoIP Feature Server replies with SIP OK to complete the service. The VoIP Feature Server updates the subscriber record in the HSS to trigger the HLR location update procedure. The HSS sends a MAP_LOCATION_UPDATE message to the HLR. Mobile terminated call redirection to the WiFi network is now complete.

[0089] **FIG. 15** illustrates a messaging and signaling flow diagram for WiFi-to-GSM voice handover. The procedural flow is described as follows. An existing voice call is established between a dual-mode handset in WiFi mode and a standard GSM handset. The call is routed through a media gateway, which provides a voice conferencing function. A hysteresis algorithm triggers the WiFi-to-GSM handover procedure. The handset sends a SIP OPTIONS message to the VoIP Feature Server to request the voice conferencing E.164 dial in number for the existing voice session. The VoIP Feature Server then generates a voice conferencing E.164 dial-in number. The VoIP Feature Server returns the voice conferencing E.164 dial-in number to the handset in a SIP OPTIONS reply. The handset retrieves the voice conferencing E.164 dial-in number. The handset sends a SIP REGISTER message with an expiration value of zero to the VoIP Server. This ends the SIP registration.

[0090] The VoIP server replies with a SIP OK message to confirm deregistration, which triggers the handset to activate the GSM transceiver and register on the GSM network by initiating a standard GSM registration and location update procedure. The handset signals the GSM network to establish a CS call via the MSC to the MRF voice conferencing function. A GSM CS bearer is established between the handset, MSC, and MRF. The handset then sends a SIP BYE message over WiFi to the VoIP Feature Server to end the WiFi packet-switched (PS) voice bearer session (1st leg). The PS voice bearer session (1st leg) is disconnected. The handover procedure is then completed.

[0091] **FIG. 16** illustrates a messaging and signaling flow diagram for GSM-to-WiFi voice handover. The procedural flow is described as follows. A GSM CS call is ongoing between the dual-mode handset and another CS destination (mobile or PSTN). The handset detects the IEEE 802.11 access point beacon signal. The handset accesses the WiFi network and authenticates the IMS client and network with the 3GPP IMS system. The dual-mode handset client sends a SIP OPTIONS message to the VoIP Feature Server to query for the E.164 conference number that it uses to bridge the voice PS session and the CS session. The VoIP Feature Server generates the E.164 conference number. The VoIP Feature Server returns the E.164 conference number to the dual-mode handset in a SIP OPTIONS message. The handset retrieves the E.164 conference number from the SIP OPTIONS message, which is used in the later SIP INVITE message. The dual-mode handset client sends a SIP REGISTER message to subscriber to the VoIP service. The VoIP Feature Server returns a SIP OK message.

[0092] The dual-mode handset sends a SIP INVITE message to setup the PS voice bearer path between the dual-mode handset and the MRF. The VoIP Feature Server returns a SIP OK message (not shown). The second leg PS voice bearer is established. The dual-mode handset sends a signaling procedure (e.g., 3GPP ECT SS) to the MSC to connect party B to the E.164 conference number. The third leg CS voice bearer is established. The first leg CS voice bearer is disconnected. Handover is complete. The VoIP Feature Server (or HSS) sends location updating message to the GSM HLR that redirects GSM MT calls to the indoor network.

[0093] FIG. 17 illustrates a message and signaling flow diagram for redirecting an MT SMS message to the WiFi handset. The procedural flow is described as follows. Initially, the subscriber is registered in the WLAN and IMS, and the IMS has updated the GSM HLR to redirect mobile terminated SMS messages to the WiFi network. The GSMSC receives an SMS message for the subscriber. The GSMSC retrieves the roaming E.164 number from the indoor network via a GSM procedure. The roaming E.164 number identifies the SGW SMS Handler as the SMS SC (switching center). The GSMSC forwards the SMS message in an SS7 MAP: Forward_Short_Message procedure to the SMS Handler. The SMS Handler processes the message content and sends it to a SIMPLE server using SIMPLE procedures. The SIMPLE server sends a SIP: MESSAGE to the subscriber. The subscriber replies with SIP OK. The mobile terminated SMS message delivery is completed.

[0094] FIG. 18 illustrates a schematic block diagram of a dual-mode handset (DMH) 1800 in accordance with an innovative aspect. In order to provide additional context for various aspects thereof, FIG. 18 and the following discussion are intended to provide a brief, general description of a suitable environment 1800 in which the various aspects of the innovation can be implemented. While the description includes a general context of computer-executable instructions, those skilled in the art will recognize that the innovation also can be implemented in combination with other program modules and/or as a combination of hardware and software.

[0095] Generally, applications (e.g., program modules) can include routines, programs, components, data structures, etc., that perform particular tasks or implement particular abstract data types. Moreover, those skilled in the art will appreciate that the inventive methods can be practiced with other system configurations, including single-processor or multiprocessor systems, minicomputers, mainframe computers, as well as personal computers, hand-held computing devices, microprocessor-based or programmable consumer electronics, and the like, each of which can be operatively coupled to one or more associated devices.

[0096] A computing device can typically include a variety of computer-readable media. Computer-readable media can be any available media that can be accessed by the computer and includes both volatile and non-volatile media, removable and non-removable media. By way of example, and not limitation, computer-readable media can comprise computer storage media and communication media. Computer storage media includes both volatile and non-volatile, removable and non-removable media implemented in any method or technology for storage of information such as computer-

readable instructions, data structures, program modules or other data. Computer storage media can include, but is not limited to, RAM, ROM, EEPROM, flash memory or other memory technology, CD-ROM, digital video disk (DVD) or other optical disk storage, magnetic cassettes, magnetic tape, magnetic disk storage or other magnetic storage devices, or any other medium which can be used to store the desired information and which can be accessed by the computer.

[0097] Communication media typically embodies computer-readable instructions, data structures, program modules or other data in a modulated data signal such as a carrier wave or other transport mechanism, and includes any information delivery media. The term "modulated data signal" means a signal that has one or more of its characteristics set or changed in such a manner as to encode information in the signal. By way of example, and not limitation, communication media includes wired media such as a wired network or direct-wired connection, and wireless media such as acoustic, RF, infrared and other wireless media. Combinations of the any of the above should also be included within the scope of computer-readable media.

[0098] The DMH 1800 (similar to handset 416) includes a processor 1802 for controlling and processing all onboard operations and functions. A memory 1804 interfaces to the processor 1802 for storage of data and one or more applications 1806 (e.g., a video player software, user feedback component software, etc.). Other applications can include voice recognition of predetermined voice commands that facilitate initiation of the user feedback signal, as well as those described infra. The applications 1806 can be stored in the memory 1804 and/or in a firmware 1808, and executed by the processor 1802 from either or both the memory 1804 or/and the firmware 1808. The firmware 1808 can also store startup code for execution in initializing the DMH 1800. A communication component 1810 interfaces to the processor 1802 to facilitate wired/wireless communication with external systems, e.g., cellular networks, VoIP networks, and so on. Here, the communications component 1810 also includes a GSM transceiver 1811 and a WiFi transceiver 1813 for corresponding signal communications. The DMH 1800 can be a device such as a cellular telephone, a PDA with mobile communications capabilities, and messaging-centric devices.

[0099] The DMH 1800 includes a display 1812 for displaying text, images, video, telephony functions (e.g., a Caller ID function), setup functions, and for user input. The display 1812 can also accommodate the presentation of multimedia content. A serial I/O interface 1814 is provided in communication with the processor 1802 to facilitate wired and/or wireless serial communications (e.g., USB, and/or IEEE 1394) via a hardware connection, and other serial input devices (e.g., a keyboard, keypad, and mouse). This supports updating and troubleshooting the DMH 1800, for example. Audio capabilities are provided with an audio I/O component 1816, which can include a speaker for the output of audio signals related to, for example, indication that the user pressed the proper key or key combination to initiate the user feedback signal. The audio I/O component 1816 also facilitates the input of audio signals via a microphone to record data and/or telephony voice data, and for inputting voice signals for telephone conversations.

[0100] The DMH 1800 includes a slot interface 1818 for accommodating a SIC (Subscriber Identity Component) in

the form factor of a card Subscriber Identity Module (SIM) **1820**, and interfacing the SIM card **1820** with the processor **1802**. However, it is to be appreciated that the SIM card **1820** can be manufactured into the DMH **1800**, and updated by downloading data and software thereinto.

[0101] The DMH **1800** can process IP data traffic via the communication component **1810** to accommodate IP traffic from an IP network such as, for example, the Internet, a corporate intranet, a home network, a person area network, etc., via an ISP or broadband cable provider. Thus, VoIP traffic can be utilized by the DMH **1800** and IP-based multimedia content can be received in either an encoded or decoded format.

[0102] A video processing component **1822** (e.g., a camera) can be provided for decoding encoded multimedia content. The DMH **1800** also includes a power source **1824** in the form of batteries and/or an AC power subsystem, which power source **1824** can interface to an external power system or charging equipment (not shown) via a power I/O component **1826**.

[0103] The DMH **1800** can also include a video component **1830** for processing video content received and, for recording and transmitting video content. A location tracking component **1832** facilitates geographically locating the DMH **1800**. As described hereinabove, this can occur when the user initiates the feedback signal automatically or manually. A user input component **1834** facilitates the user initiating the quality feedback signal. The input component can include such conventional input device technologies such as a keypad, keyboard, mouse, stylus pen, and touch screen, for example.

[0104] Referring again to the applications **1806**, a hysteresis component **1836** facilitates the analysis and processing of hysteresis data, which is utilized to determine if to associate with the IAP. A software trigger component **1838** can be provided that facilitates triggering of the hysteresis component **1838** when the WiFi transceiver **1813** detects the beacon of the IAP. In an active mode, the DMH GSM/WiFi handset **1800** can be equipped with the following functionality. A SIP client **1840** enables the DMH **1800** to support SIP protocols and register the subscriber with the SIP registrar server.

[0105] The DMH **1800**, as indicated supra related to the communications component **1810** includes an indoor network radio transceiver **1813** (e.g., WiFi transceiver). This function supports the indoor radio link, such as IEEE 802.11, for the dual-mode GSM handset **1800**.

[0106] FIG. 19 illustrates an exemplary GSM network **1900** that facilitates call redirection according to an innovative aspect. The GSM system, designed as a 2G cellular communications system, utilizes TDMA (time division multiple access) technology to enable greater call capacity. Digitally-encoded speech can also be ciphered to retain call privacy. Voice calls are the primary function of the GSM system. To achieve this, the speech is digitally encoded, and later decoded using a vocoder.

[0107] GSM also supports a variety of other data services, although the performance for such data services (e.g., facsimile videotext and teletext) is slow. One data service includes SMS that allows bi-directional messaging, store-and-forward delivery, and alphanumeric messages. The

overall system definition for GSM describes not only the air interface, but also the network. GSM uses 200 KHz RF channels, and are typically multiplexed to, for example, enable eight users to access each carrier.

[0108] The GSM network **1900** includes a base station subsystem (BSS) **1902**, a network subsystem (NSS) **1904** and a GPRS core network **1906**. The BSS **1902** can include one or more base transceiver stations (BTS) **1908** and a base station controller (BSC) **1910** connected together on an A-bis interface. The BTS and accompanying base stations (not shown) connect a cell phone to a cellular network. Base stations are all interconnected to facilitate roaming from one cell to another via a process called handover, without losing the cell connection.

[0109] A packet control unit (PCU) **1912** is shown connected to the BTS **1910** although the exact position of this can depend on the vendor architecture. The BSS **1902** is connected by the air interface Um to a mobile terminal **1914**. The BTS **1908** are the actual transmitters and receivers of radio signals. Typically, a BTS for anything other than a picocell will have several different transceivers (TRXs) which allow it to serve several different frequencies or even several different cells (in the case of sectorized base stations).

[0110] By using directional antennae on a base station, each pointing in different directions, it is possible to sectorize the base station so that several different cells are served from the same location. This increases the traffic capacity of the base station (each frequency can carry eight voice channels) while not greatly increasing the interference caused to neighboring cells (in any given direction, only a small number of frequencies are being broadcast).

[0111] The BSC **1910** provides the intelligence behind the BTS **1908**. Typically, a BSC can have tens or even hundreds of BTSs **1908** under its control. The BSC **1910** handles allocation of radio channels, receives measurements from the mobile phones, and controls handovers from BTS to BTS (except in the case of an inter-MSC handover in which case control is in part the responsibility of the an MSC). One function of the BSC **1910** is to act as a concentrator such that many different low capacity connections to the BTS **1908** can become reduced to a smaller number of connections towards the MSC. Generally, this means that networks are often structured to have many BSCs **1910** distributed into regions near the BTS **1908** which are then connected to large centralized MSC sites.

[0112] The PCU **1912** can perform some of the equivalent tasks of the BSC **1910**. The allocation of channels between voice and data can be controlled by the base station, but once a channel is allocated to the PCU **1912**, the PCU **1912** takes full control over that channel. The PCU **1912** can be built into the base station, built into the BSC, or even in some architectures, it can be at an SGSN site.

[0113] The BSS **1902** connects to the NSS **1904** by an A interface. The NSS **1904** is shown containing an MSC **1916** connected via an SS7 network **1918** to an HLR **1920**. The AuC and the EIR, although technically separate functions from the HLR **1920**, are shown together since combining them can be performed in the network.

[0114] The combination of a cell phone **1914** and a SIM card (not shown) creates a special digital "signature" that

includes a subscriber number which is sent from the cell phone **1914** to the nearest BTS **1908** asking that the subscriber of a particular network be allowed to use the network. The request is passed on along the network of BTS **1908** to the heart of a cellular network, the MSC **1916**. The MSC also routes all incoming and outgoing calls to and from the fixed-line networks or other cellular networks. When the user wants to make an outgoing call, another section of the MSC called the VLR checks whether the caller is actually allowed to make that call. For example, if the caller is barred for international dialing, a message to that effect will be generated by the VLR, sent along the network, and almost instantly back to the cell phone.

[**0115**] The MSC **1916** also contains the component called HLR **1920** that provides the administrative information required to authenticate, register and locate the caller as that network's subscriber. Once the HLR has received a log-on request, the HLR **1920** immediately checks the special "signature" contained in the request against the HLR special subscriber database. If the subscription is current, the MSC **1916** sends a message back to the phone via the network of BTS **1908** that indicates the caller is allowed to access the network. The name or code of that network will appear on the LCD screen of the cell phone **1914**. Once this network "name" message appears on the phone LCD screen, it means the caller is connected to the network and able to make and receive calls.

[**0116**] The HLR **1920** registers which base station the cell phone is currently connected to, so that when the network MSC **1916** needs to route an incoming call to the cell phone number, it will first check the H-LR **1920** to see where the cell phone is located. Periodically, the cell phone will send a message to the network indicating where it is, in a process called polling. The combination of the tracking function and the caller's unique digital signature allows the MSC **1916** to route that call to the precise base station the cell phone happens to be connected to, and then exclusively to the cell phone, even if a number of other subscribers are simultaneously connected to that base station.

[**0117**] When traveling to another cell while driving, for example, the HLR **1920** is automatically updated, and continues to monitor where exactly it should route the calls should the caller then move within range of another base station. This routing procedure means that out of hundreds of thousands of subscribers, only the correct cell phone will ring when necessary.

[**0118**] The NSS **1904** has a direct connection to the PSTN **1922** from the MSC **1916**. There is also a connection to from the NSS **1904** to the GPRS core network **1906** via a Gr/Gs interface although this is optional and not always implemented. The illustrated GPRS Core Network **1906** is simplified to include a SGSN **1924** (connected to the BSS **1902** by the Gb interface) and a GGSN **1926**. The SGSN **1924** and the GGSN **1926** are connected together by a private IP network **1928** called a GPRS backbone shown as the Gn reference point. A computer **1930** is depicted as connecting to the core network **1906** via an Internet or corporate network **1932**.

[**0119**] Some voice mail systems are linked to a network SMS Center (SMSC), a special facility that handles short messages. The SMSC generates the special SMS message that notifies the caller when they have mail waiting in a

Mailbox. SMS messages can be received on an SMS-capable cell phone even while the caller is on a voice call. This is because the SMS messages are sent on a different radio frequency, the GSM data channel, than voice calls, so that the two never interfere.

[**0120**] What has been described above includes examples of the disclosed innovation. It is, of course, not possible to describe every conceivable combination of components and/or methodologies, but one of ordinary skill in the art may recognize that many further combinations and permutations are possible. Accordingly, the innovation is intended to embrace all such alterations, modifications and variations that fall within the spirit and scope of the appended claims. Furthermore, to the extent that the term "includes" is used in either the detailed description or the claims, such term is intended to be inclusive in a manner similar to the term "comprising" as "comprising" is interpreted when employed as a transitional word in a claim.

What is claimed is:

1. A system that facilitates redirection of a call, comprising:
 - a trigger component that facilitates triggering on a signal associated with a handset used in making the call; and
 - a redirection component that initiates a redirection process between a cellular network and a local network based in part on the signal.
2. The system of claim 1, wherein the signal is from a wireless access point.
3. The system of claim 2, wherein the signal is an unlicensed spectrum beacon signal of the wireless access point.
4. The system of claim 2, wherein the wireless access point is inside a residence.
5. The system of claim 1, wherein the redirection component automatically redirects the call between a GSM cellular network and a home WiFi network.
6. The system of claim 1, wherein the trigger component triggers on at least one of presence and absence of a wireless beacon signal.
7. The system of claim 1, wherein the trigger component triggers on at least one of an ability or inability to access or use a wireless access point.
8. A mobile handset that employs the system of claim 1.
9. The system of claim 1, wherein the redirection component facilitates handover of the call from between the cellular network and the local network while maintaining uninterrupted voice communications of the call.
10. The system of claim 9, wherein the local network is a VoIP network.
11. The system of claim 1, wherein the trigger component facilitates power-up of a handset.
12. The system of claim 1, wherein the trigger component facilitates power-up of a WiFi transceiver of a handset.
13. The system of claim 12, wherein the trigger component receives a signal from a VoIP server that initiates power-up of the WiFi transceiver.
14. The system of claim 13, wherein the VoIP server runs a GSM inter-working function (IWF).
15. The system of claim 1, wherein the trigger component triggers a hysteresis algorithm that facilitates determination of association with an access point.

16. The system of claim 1, wherein the trigger component triggers a GSM registration and location update procedure.

17. The system of claim 16, wherein the GSM registration and location update procedure is associated with cancellation of the redirection process of the call.

18. The system of claim 1, wherein the redirection component facilitates redirection of data.

19. The system of claim 18, wherein the data is an SMS message.

20. A system that facilitates redirection of data, comprising:

a trigger component that facilitates triggering on a signal associated with a multi-mode mobile handset; and

a redirection component that initiates redirection of the data between a circuit-switched network and a packet-switched network based in part on the signal.

21. The system of claim 20, wherein the multi-mode handset operates in both a GSM network and a WiFi network.

22. The system of claim 20, wherein the mobile handset is a GSM handset that operates over the circuit-switched network, and utilizes SIP signaling through the packet-switched network.

23. The system of claim 20, wherein the data is a telephone call such that the redirection component facilitates call handover between the circuit-switched network and the packet-switched network.

24. The system of claim 20, wherein the trigger component facilitates detection of the mobile handset in a home in which the packet-switched network extends, and outside the home in which the circuit-switched network extends.

25. A system that facilitates redirection of data, comprising:

a trigger component that facilitates triggering on a signal associated with a GSM/WiFi mobile handset; and

a redirection component that initiates redirection of a telephone call between a GSM network and a WiFi network of a home based in part on the signal.

26. The system of claim 25, wherein a subscriber at least one of originates and terminates the telephone call in the home using at least one of a legacy wireline telephone, the GSM/WiFi mobile handset operating in a cordless telephone mode, and a wired VoIP telephone.

27. The system of claim 25, wherein signaling and bearer traffic is routed to and from the home via at least one of a POTS connection and a broadband connection.

28. The system of claim 25, wherein a mobile number of the handset is utilized as a main number such that the telephone call is first routed to a home PLMN, and thereafter, forwarded to the home.

29. The system of claim 28, wherein the redirection of the telephone call is automatically activated and deactivated from the home PLMN to the home via at least one of a POTS connection and a broadband connection.

30. The system of claim 25, wherein the redirection component facilitates automatic registration between an IMS and a PLMN.

31. The system of claim 30, wherein the PLMN is a home PLMN, and the redirection component facilitates GSM registration to the home PLMN using MAP signaling.

32. The system of claim 25, wherein the redirection component facilitates redirection of a VoIP call to a number without routing the telephone call through a GSM gateway MSC.

33. The system of claim 25, wherein the redirection component facilitates automatic voice handover from the WiFi network to the GSM network that is transparent to a party of the telephone call.

34. The system of claim 25, wherein the trigger component facilitates automatic power-on of a WiFi transceiver of the mobile handset, and WiFi automatic registration thereof.

35. A method of controlling a communication signal, comprising:

receiving a mobile handset that can facilitate a telephone call;

bringing the mobile handset into communications range of a network;

triggering on a signal associated with the network; and

redirecting the telephone call between a circuit-switched network and a packet-switched network of a home based in part on the signal.

36. The method of claim 35, further comprising an act of powering-up a WiFi transceiver of the handset in response to the act of bringing.

37. The method of claim 35, further comprising an act of removing the handset from communications range of the network.

38. The method of claim 37, further comprising an act of automatically powering-down a WiFi transceiver of the handset in response to the act of removing.

39. The method of claim 35, further comprising an act of initiating WLAN subsystem registration and authentication via a WLAN subsystem.

40. The method of claim 35, further comprising an act of initiating IMS registration and authentication, which includes subscribing to a VoIP service.

41. The method of claim 35, further comprising acts of initiating a location update procedure and routing the telephone call to the packet-switched network via an IMS gateway/media resource function.

42. The method of claim 35, further comprising acts of: activating redirection of the call with the handset; and deactivating redirection of the call using a cellular network.

43. A method of controlling a communications signal, comprising:

receiving a mobile handset that can facilitate a telephone call;

sensing the mobile handset via an indoor access point of a WiFi network;

associating the handset with the WiFi network of a building;

initiating a WLAN registration and authentication procedure via a handset WiFi client;

initiating an IMS registration and authentication procedure;

initiating a location update procedure; and

routing the telephone call from a circuit-switched network to the WiFi network of the building via an IMS entity.

44. The method of claim 43, further comprising acts of:

- sending a signal from the indoor access point of the building to a VoIP server; and
- triggering the handset to power-on via the VoIP server.

45. The method of claim 43, wherein the mobile handset is a GSM/WiFi handset and the circuit-switched network is a PSTN network.

46. The method of claim 43, further comprising an act of treating an indoor network of the building as a pseudo visitor PLMN by a home PLMN which does not require GSM radio coverage in the indoor network.

47. A method of controlling a communications signal, comprising:

- receiving a mobile handset that can facilitate a telephone call;
- sensing absence of the mobile handset via an indoor access point of a WiFi network;
- initiating a GSM registration and location update procedure via the handset; and
- routing the telephone call over a GSM network to the handset.

48. The method of claim 47, further comprising an act of canceling redirection of the telephone call to a WiFi network in response to performing the act of initiating.

49. The method of claim 47, further comprising powering-on a GSM transceiver in response to the act of sensing.

50. The method of claim 47, further comprising an act of canceling redirection of data to a WiFi network in response to performing the act of initiating.

51. The method of claim 47, further comprising an act of sending the indoor network a location cancellation message from the GSM network.

52. A method of controlling a communications signal, comprising:

- receiving a mobile handset that can facilitate a telephone call;
- sensing absence of the mobile handset via an indoor access point of a WiFi network;
- triggering an SIP client of the handset;
- initiating a VoIP conference session in response to the act of triggering;
- returning a conference meeting number associated with the conference session to the handset;
- initiating a call to the conference meeting number; and
- dropping a voice session to complete handover of the telephone call from the WiFi network to a GSM network.

53. The method of claim 52, the number is an E.164 number.

54. The method of claim 52, wherein the act of triggering occurs in response to an existing VoWLAN call.

55. A method of controlling a communications signal, comprising:

- receiving a mobile handset that facilitates a telephone call;

- sensing the mobile handset via an indoor access point of a WiFi network;
- registering the handset to an IMS system and subscribing the handset to a VoIP service via an SIP client of the handset;
- initiating an IMS conference VoIP session;
- returning a conference meeting number associated with the conference session to a GSM client of the handset;
- connecting a GSM call leg to a WiFi VoIP call leg via a VoIP conference server; and
- dropping the GSM call leg to complete handover of the telephone call from a GSM network to the WiFi network.

56. The method of claim 55, further comprising an act of initiating a GSM ECT procedure to connect the GSM call leg to the WiFi VoIP call leg.

57. The method of claim 55, further comprising performing the act of dropping in response to successfully executing the act of initiating the GSM ECT procedure.

58. A method of redirecting a voice call, comprising:

- receiving a mobile handset of a subscriber that facilitates a telephone call;
- sensing the mobile handset via an indoor access point of a WiFi network;
- initiating a GSM location update procedure via an HSS;
- querying the HSS for a dual mode roaming number of the subscriber;
- routing a circuit-switched call to an IMS and a VoIP conference server;
- transcoding the circuit-switched call to VoIP data; and
- connecting the telephone call to the handset.

59. The method of claim 58, wherein at least one of the HSS and the VoIP server runs IWF to facilitate a MAP communication.

60. A method of redirecting communications information, comprising:

- receiving a mobile handset of a subscriber that facilitates a telephone call;
- performing a GSM location update MAP procedure;
- redirecting SMS messages from a home PLMN to a roaming number of the subscriber;
- performing a MAP query to obtain the roaming number of the subscriber;
- sending the SMS message to an SMS message handler;
- filtering the SMS message; and
- converting the filtered SMS message into a SIP instant messaging message.

61. The method of claim 60, wherein the roaming number is an E.164 number, and the SMS message is sent via an SS7 system.

* * * * *