



Electronic Communications Committee (ECC)
within the European Conference of Postal and Telecommunications Administrations (CEPT)

MMS-MULTI MEDIA MESSAGING AND MMS-INTERCONNECTION

Brugge, November 2004

INDEX TABLE

1	INTRODUCTION	3
2	REFERENCES	3
3	WHAT IS MMS?	3
3.1	INTRODUCTION	3
3.2	COMPARISON BETWEEN MMS, EMAIL AND SMS	5
3.3	COMPARISON BETWEEN MMS AND INSTANT MESSENGER SERVICES	6
4	TECHNICAL OVERVIEW OF MMS	7
4.1	OVERVIEW	7
4.2	MMS ELEMENTS	8
4.3	ADDRESSING	9
4.4	MMS REFERENCE ARCHITECTURE.....	10
4.5	MM4: INTERWORKING OF DIFFERENT MOBILE NETWORKS	10
4.5.1	<i>Message format on MM4</i>	11
4.5.2	<i>Interworking case using GPRS</i>	11
4.5.3	<i>Roaming</i>	12
4.5.4	<i>IP-network</i>	12
4.5.5	<i>GRX</i>	12
4.5.6	<i>Mobile Number Portability</i>	12
4.6	INTERWORKING WITH FIXED NETWORK MMS.....	13
4.7	MM7: VALUE ADDED SERVICES	14
5	INTERCONNECTION	14
5.1	CURRENT STATUS	14
5.2	INTERCONNECTION BILLING.....	15
6	END-USER BILLING	15
	ANNEX A: ABBREVIATIONS	16

1 INTRODUCTION

This Report is a tutorial on MMS - the relatively new messaging service that is used mainly at present for sending images taken by camera phones. The report explains what MMS, how it works and how it compares to other forms of messaging. It includes information on the arrangements for interconnection and on the current state of development of the service.

2 REFERENCES

For the purposes of this report, the following references apply:

- [1] 3GPP TS 22.140 V5.4.0: "3rd Generation Partnership Project; Technical Specification Group Services and System Aspects; Multimedia Messaging Service (MMS); Stage 1 (Release 5)" (identical to ETSI TS 122.140), <http://www.3gpp.org>
- [2] 3GPP TS 23.140 V5.4.0: "3rd Generation Partnership Project; Technical Specification Group Terminals; Multimedia Messaging Service (MMS); Functional description; Stage 2 (Release 5)" (identical to ETSI TS 123.140)
- [3] ETSI ES 202 314-4 V1.1.1 "ETSI Standard Access and Terminals (AT); Fixed network Multimedia Messaging Service (F-MMS); PSTN/ISDN; Part 4: Multimedia Message communication between a fixed network Multimedia Messaging Terminal Equipment and a Multimedia Messaging Service Centre"
- [4] GSMA IR.34 V3.4.0: "Inter-PLMN Backbone Guidelines, March 2003", <http://www.gsmworld.com>
- [5] GSMA IR.52 V3.1.0: "MMS Interworking Guidelines; February 2003"
- [6] IETF RFC2821: "Simple Mail Transfer Protocol (SMTP), April 2001" (obsoletes RFC821, also referred to as STD10), <http://www.ietf.org>
- [7] IETF RFC2822: "Internet Message Format" (obsoletes RFC822, also referred to as STD11)
- [8] ITU-T E.164: "The international public telecommunication numbering plan", <http://www.itu.int>

3 WHAT IS MMS?

3.1 Introduction

MMS is a server based multi-media messaging system designed for sending multimedia messages:

- between mobiles, where the recipient is addressed by their E.164 number
- between mobiles and other messaging systems such as email, where the recipient is addressed by their email address.

The choice of identifier for the recipient (eg E.164 number or email address) determines the method of delivery used. The multimedia messages consist of one or more items attached to a text message and the most common use at present is sending images taken by camera phones.

MMS is intended partly as a multimedia replacement or upgrade for SMS, but in practice it is likely that both SMS and MMS will exist alongside each other for the foreseeable future, and SMS is used to activate some of the features in MMS.

Sending MMS messages requires a mobile that is capable of generating a message type other than text, such as a camera phone, whereas receiving an image may be possible on a simpler phone without a camera.

Figure 1 below shows an MM containing a single image, which has been received as an email:



Figure 1: Sample MM received as e-mail

This message contains only a single image, but an MMS could also include text, voice-clips or video-clips, in this case the result would be an email containing a list of attachments as in figure 2.

To: a@eggern.at		
Priority: Normal		
Options: View Full Header View Printable Version		
<hr/>		
Attachments:		
bild(24).jpg	34 k	[image/jpeg]
memo 7.wav	191 k	[audio/x-wav]
cid: mms.txt	0 k	[text/plain]
bild(25).jpg	27 k	[image/jpeg]

Figure 2: MM with more attachments received as email

3.2 Comparison between MMS, email and SMS

It is important to understand the differences between MMS, email and SMS. The three services differ in what they can send, who they can send to and what charges are paid. The following table summarises the differences.

	MMS	e-Mail	SMS
Size of message	Limited to max. 100 kBytes, sometimes even lower (e.g. 50 kBytes)	No generally accepted limit, usually 2-10 MBytes are supported	140 bytes or 160 characters per SMS (may be concatenated)
Message may include text and simple images	Yes	Yes	Yes
Message may include images and voice-clips	Yes	Yes	No
Message may include arbitrary attachments (e.g. Word documents or executables)	No	Yes	No
Recipient identified by	E.164 number or email address	Email address	E.164 number
MMS message can be sent to	All MMS-phones from own operator and from other operators when interconnected for MMS, Any email account on the Internet	Any email account on the Internet	Any mobile, but gateways may forward SMSs to email accounts
MMS message can be received from	All MMS-phones and from operator (e.g. premium rate) but not from the Internet ¹	Any email account on the Internet	All phones and from operator (e.g. premium rate)
Interoperability	Low, often requires converting at MMSC	High	High
Message transfer	Messages are transferred from senders server to receiver's server	Messages are transferred from senders server to receiver's server	Messages are transferred from senders server to receiver's mobile
Method of receiving message	Mobile is informed by SMS of the incoming message and message may be pulled down automatically or at request of user	Messages are normally pulled down by user or by their software	Messages are pushed to the mobile
Tariff	Sending typically 0,50 EUR ² , reception is free	Free, but the access to the email server may be charged	Sending typically 0,1-0,25 EUR, reception is free
Resources of standard phone are sufficient	Yes	No, only small and "simple" messages can be sent/received	Yes ³

The limitation in the maximum size of a MMS is probably due to the limited capabilities of terminals and the low available bandwidth. Similar limits apply to e-mail clients implemented in an average mobile.

Access to emails from mobiles is expensive. Today rates for GPRS are rather different from operator to operator, but a "typical" rate might be around 1 EUR/MByte being charged in segments of 250 kByte. Therefore, the cost of a message exchanged via e-mail from a mobile would be approximately the same as using MMS (0,50 EUR per MMS or 2 times 0,25 EUR minimum charge for an GPRS session).

¹ Technically it would be possible to allow MMS to be received from the Internet, but for charging and security (Spam) reasons operators do not support this option.

² All tariffs mentioned in this document are only indications of magnitude, no market-data or legal limits

³ Reception of SMS is required by the standards for all GSM-phones.

Figure 3 shows the different forms of messaging available to a mobile terminal.:

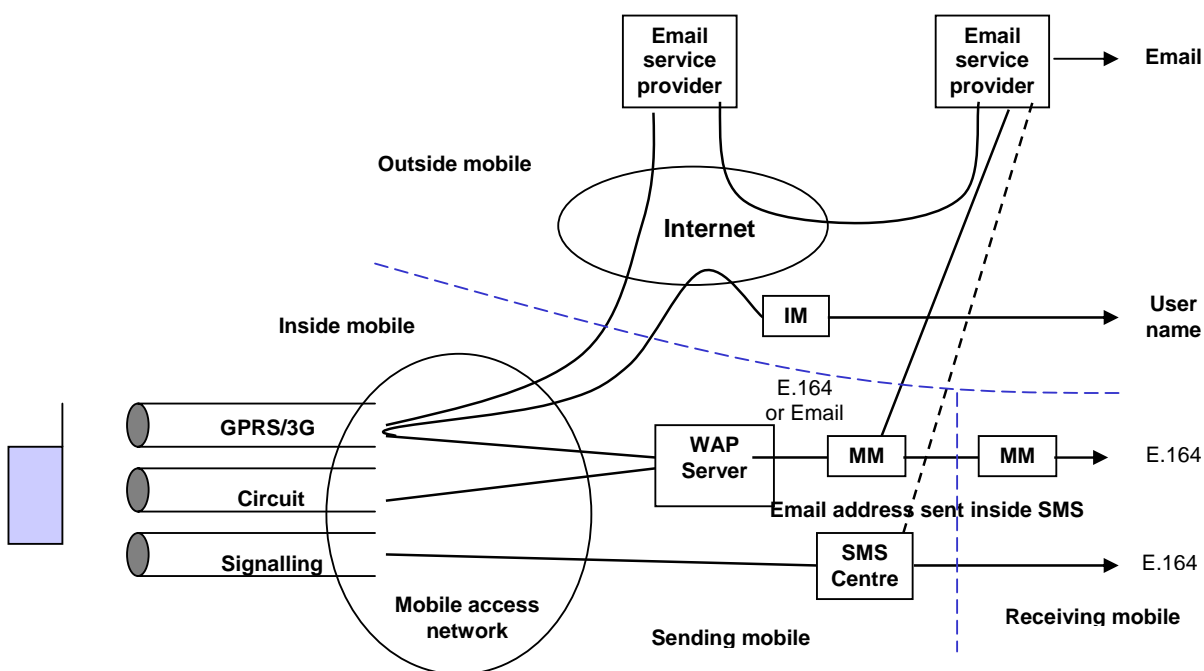

Figure 3: Principle of MMS communications

3.3 Comparison between MMS and Instant Messenger Services

Instant Messenger (IM) Services have been popular on the Internet for years (MSN-messenger, etc). The availability of Internet access over GPRS and 3GPP will make Internet based IMS services accessible from mobiles. The Multimedia Core Network Subsystem (IMS) of 3GPP Release 5 provides standardised functionality based on SIP which can be used to create a mobile IM service (see figure 4).

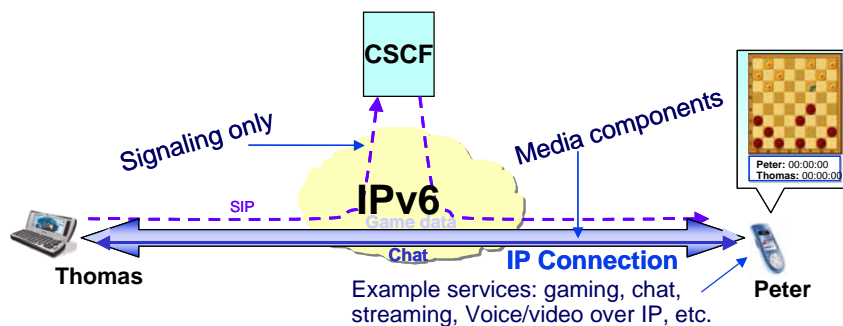

Figure 4: Sample IM (IMS) configuration

IM services are mostly session based and are characterized by:

- Near real-time two-way communication, originally text-based ("chat")
- May provide a "friend"- or "buddy"-list
- May provide status information (e.g. user is available, away, busy...)
- All participants are required to be online at the same time (no "store and forward"-principle).

Instant messaging differs from e-mail/MMS/SMS in the immediacy of the message exchange and also makes a continued exchange simpler than sending e-mail back and forth.

	MMS	IM
Both parties need to be online at the same time	No	Yes
Allows "store and forward"	Yes	No
Provides online-status of party (presence service)	No	Yes
Real time communication	No, but delay is low (some seconds)	Yes
Tariff	Per message sent	"Free", only cost of access
Scope	Originally mobile GSM-like networks, today extended to fixed networks	Originally Internet, to be extended to 3G networks
Addressing	E.164 or email address	Various naming conventions
Architecture	Client-server	Client-server for presence-service but communication flows are peer-to-peer

4 TECHNICAL OVERVIEW OF MMS

4.1 Overview

While the user-interface is intended to be very similar to SMS, the technical implementation is quite different. While SMS uses the signalling network (SS7) for transport of messages, MMS is based on the wireless application protocol (WAP), which runs over either:

- packet switched data (GPRS/3GPP) or
- circuit switched data (CSD) bearers.

MMS has been standardized by 3GPP [1, 2] and the standards have been published by ETSI.

WAP is an industry standard produced by the WAP-forum, which has been integrated into the Open Mobile Alliance (OMA, <http://www.openmobilealliance.org/>). The work of the WAP Forum continues in the different Working Groups of OMA.

Although WAP used circuit switched bearers initially, today GPRS is mostly used. The current implementations of GPRS only allow the mobile (and not the network) to activate a new context (session). In order to allow a mobile also to receive MMS, the network sends a SMS indicating a new MMS to the mobile. The mobile then activates a GPRS context and receives the MMS.

Figure 5 shows a generalized view of the Multimedia Messaging Service architecture. It combines different networks and network types and integrates messaging systems already existent within these networks. The terminal operates in the Multimedia Messaging Service Environment, MMSE. This environment comprises 2G and 3G networks, 3G networks with islands of coverage within a 2G network and roaming networks. The MMSE provides all the necessary service elements, e.g. delivery, storage and notification functionality. These service elements may be located within one network or distributed across several networks or network types.

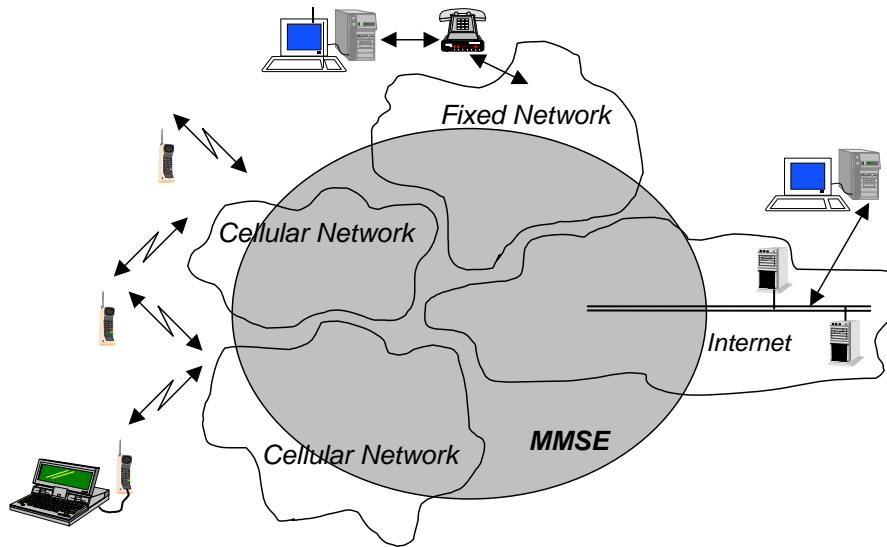

Figure 5: General view of MMS provision within the different networks [2]

4.2 MMS Elements

Figure 6 shows that multimedia messaging may encompass many different network types. The basis of connectivity between these different networks is provided by the Internet protocol and its associated set of messaging protocols. This approach enables messaging in 2G and 3G wireless networks to be compatible with messaging systems found on the Internet.

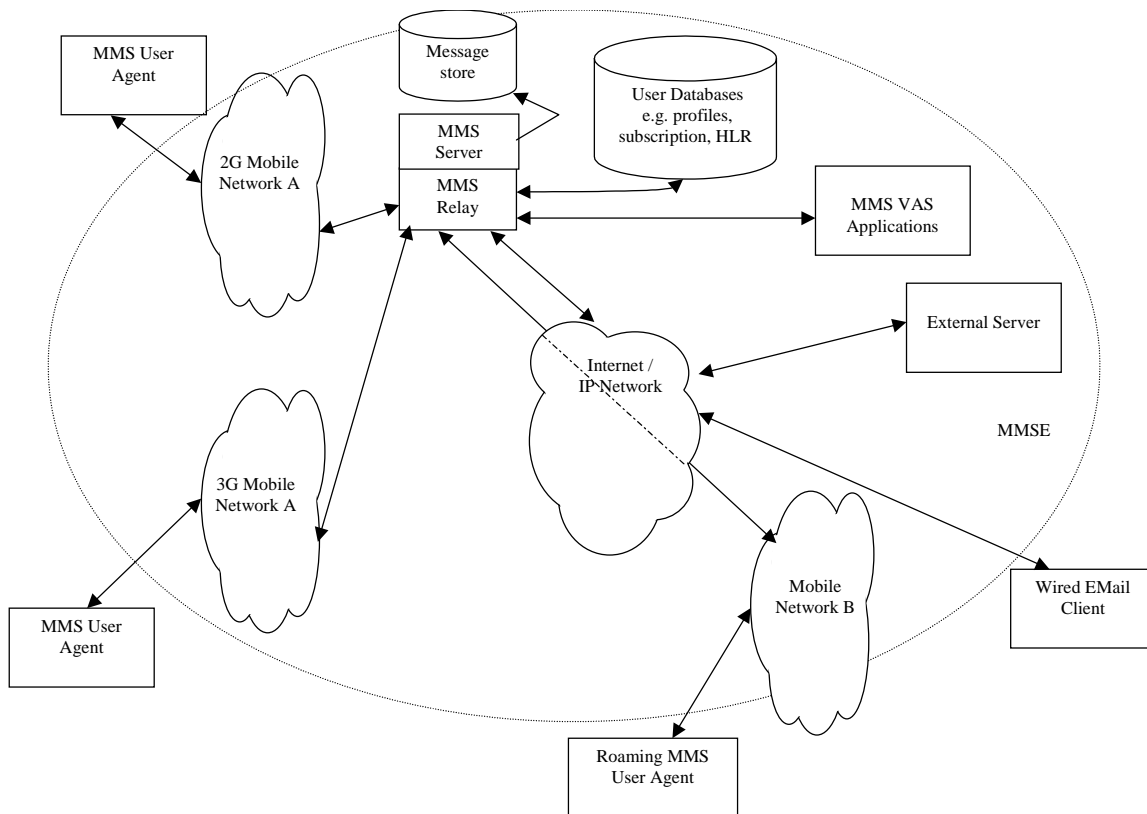

Figure 6: MMS Architectural Elements[2]

The MMS Relay/Server is the main MMS-specific element required to enable MMS within an existing GSM/UMTS network. It is responsible for storage and handling of incoming and outgoing messages and for the transfer of messages between different messaging systems. Depending on the business model, the MMS Relay/Server may be a single logical element or may be separated into MMS Relay and MMS Server elements. These may be distributed across different operators/networks. The MMS Relay/Server is able to generate charging data (Charging Data Record - CDR) when receiving or delivering MMs.

4.3 Addressing

MMS supports the use of Internet-E-Mail addresses (RFC 2822) [7] or MSISDN (E.164[8]) or both to address the recipient of an MM. In the case of E-Mail addresses standard Internet message routing is used. If MSISDN-addressing is used, the recipient can either be on the own mobile network or a different service provider's domain, in this case, the MM4 protocol is used to transfer the message from one MMS Relay/Server to another.

Examples: RFC2822: user@domain.tld
 E.164: +12345678901

4.4 MMS Reference Architecture

Figure 7 shows the MMS Reference Architecture, and identifies reference-points (MM1-8):

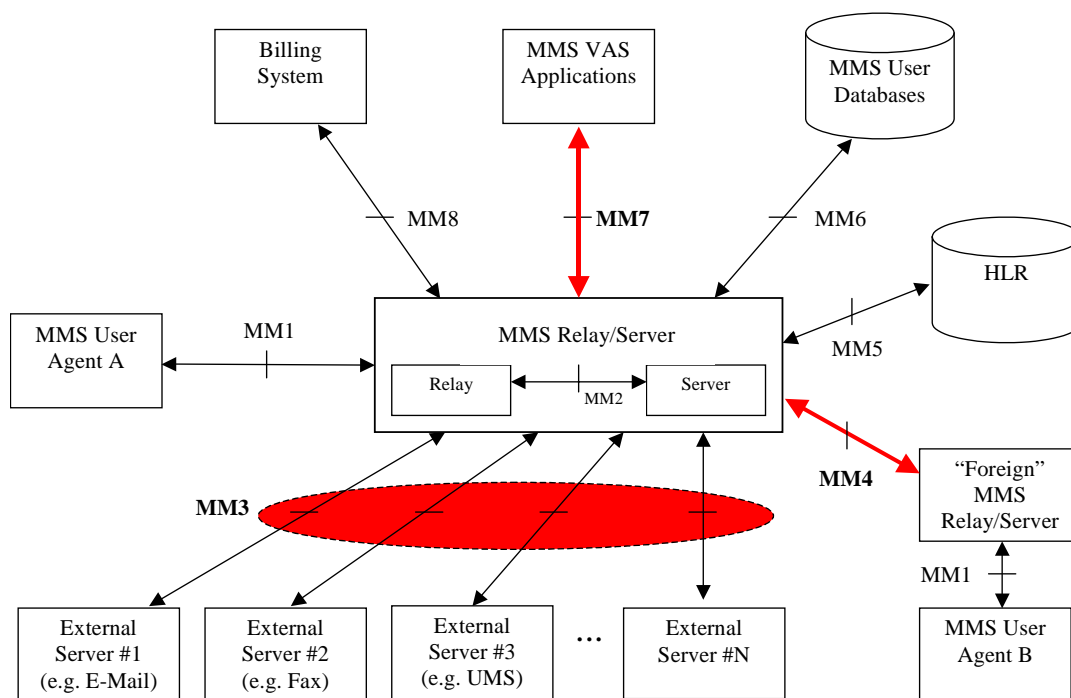

Figure 7: MMS Reference Architecture [2]

The interfaces in the MMS Reference Architecture are:

- MM1: The reference point between the MMS User Agent and the MMS Relay/Server.
- MM2: The reference point between the MMS Relay and the MMS Server.
- MM3: The reference point between the MMS Relay/Server and external (legacy) messaging systems.
- MM4: The reference point between the MMS Relay/Server and another MMS Relay/Server that is within another MMSE.
- MM5: The reference point between the MMS Relay/Server and the Home Location Register (HLR).
- MM6: The reference point between the MMS Relay/Server and the MMS User Databases.
- MM7: The reference point between the MMS Relay/Server and MMS VAS Applications.
- MM8: The reference point between the MMS Relay/Server and a billing system.

4.5 MM4: Interworking of different mobile networks

In contrast to the SMS-scenario, where the message is always sent via the "home" network SMSC of the sender to the recipient terminal (this is valid also in case of roaming), multi media messages are always delivered through the "home" network MMSC of the recipient. This implies the necessity of an intra-MMSC-protocol - MM4. Due to the higher number of network elements involved, MMS interworking is considerably more complex than SMS interworking.

Reference point MM4 between MMS Relay/Servers belonging to different MMSEs (eg. different mobile network operators) is used to transfer messages between them. Interworking between MMS Relay/Servers is based on the standard Internet e-Mail protocol (SMTP [6]) as depicted in figure 8.

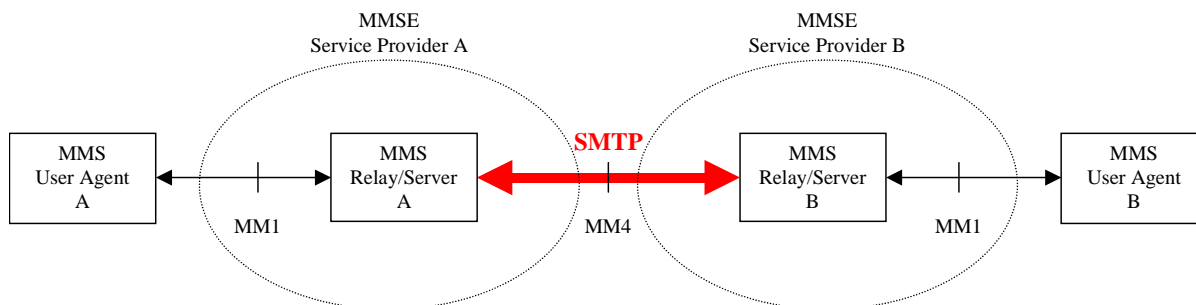

Figure 8: Interworking of different MMSEs[2]

4.5.1 Message format on MM4

All elements of an MM are included within a single SMTP "mail" message, which is organized as MIME (Multipurpose Internet Mail Extensions) encoded message with the appropriate 'Content-Type' [44] header field value (e.g. multipart/related, multipart/mixed, image/jpeg, text/plain). All MM elements are of standard MIME content types. In addition to the MM elements this SMTP "mail" message reflects all MMS-specific (additional) information elements (eg. MMS-Message-Type).

All other MMS-related messages, such as delivery reports, read-reply reports, transfer acknowledgements are each transferred as a single SMTP "mail" message is organized as MIME type text/plain. This SMTP "mail" message reflects all MMS-specific information elements.

4.5.2 Interworking case using GPRS

The example below shows a simplified case of a MMS being sent from a mobile within network A to a mobile on network B:

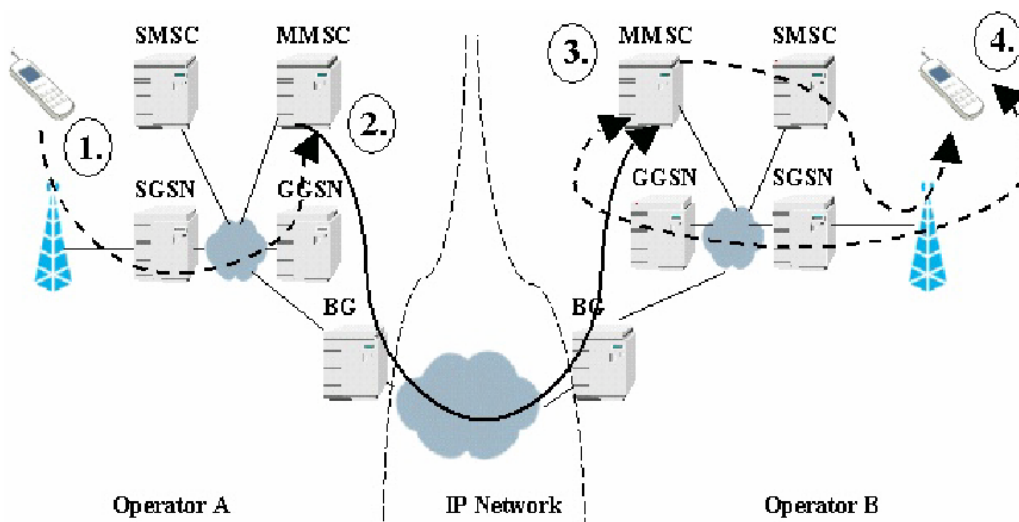

Figure 9: Interworking of different MMSEs[5]

1. The terminal of user A sends a MM with a recipient address in network B
2. The MMSC inside network A notices that the recipient MSISDN is within network B, it resolves the IP address of the MMSC of network B and forwards the MMS to this MMSC through the IP network in between. As usual - some firewalls and Email-gateways might be in between, but they should not do any harm to the message.
3. The MMSC of network B uses the WAP-push mechanism (eg. it sends an SMS) to inform user B of an incoming MM.
4. The terminal of user B receives notification carrying information such as subject, size and URL of an incoming message. Based on this information the terminal creates a GPRS context and fetches the MM by connecting to the MMSC.

4.5.3 Roaming

Regardless of terminal A or B roaming in a network different from their home network, the MM is always sent to the home network MMSC of user A and received from the home network MMSC of user B.

4.5.4 IP-network

The "IP network" can either be

- the public Internet,
- VPN using the public Internet,
- a private (leased) line dedicated for MM interconnection or
- using a GRX (a GPRS-roaming exchange established so simplify GPRS roaming).

While the use of either solution might be appropriate to some networks (eg. leased line to other national operators, GRX to remote low traffic operators) its combination can case rather complex situations since GRX and the public Internet (and also some private VPNs) have different DNS-hierarchies.

4.5.5 GRX

The figure 10 below shows a GRX network which can also be used for the exchange of MMS between networks:

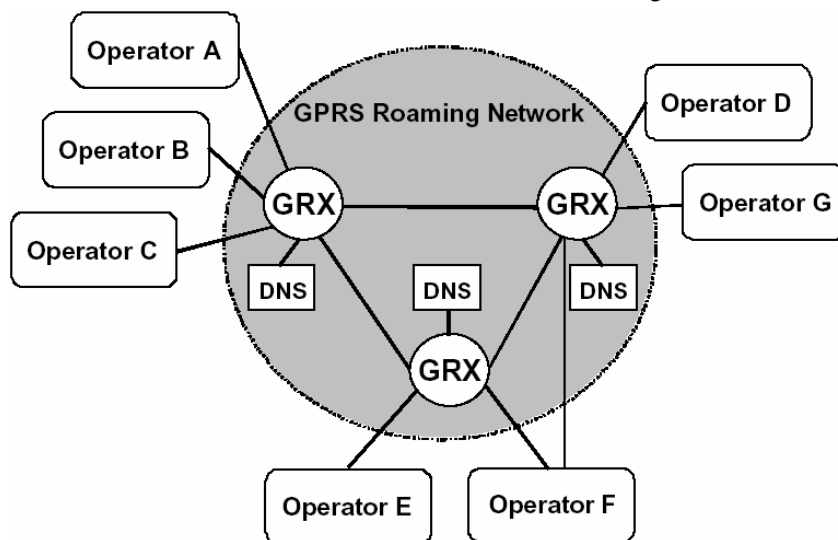

Figure 10: GPRS Roaming network architecture: [4]

The DNS servers show in figure 10 provide name service resolution for the internal TLD .gprs which is a "TLD" not existing on the public Internet (not delighted by ICANN). This results in addresses like "+1234567890/TYP=PLMN@mms.mnc123.mcc456.gprs" in the RCPT TO header field inside an SMTP message on the MM4 interface.

4.5.6 Mobile Number Portability

Due to the mandatory introduction of mobile number portability in EU-countries, routing of mobile numbers can no longer be based on a few leading digits, an additional query of a portability database is required. Number portability is only applied to E.164 numbers, it therefore has no direct impact on Internet-Addresses used in GPRS. But as MMS can use E.164 numbers for identifying recipients, porting information is also required for MMS. Two methods have been identified for [5] for gaining porting information (direct routing):

- Operator-ENUM as defined in TS 123.140 appendix G [2]: requires ENUM-database in the originating network. This option does not require the MMSC to have direct access to the SS7-signalling network. On the other hand it requires the operators portability-database to provide NAPTR-records to the MMSC. As long as ENUM-databases are operator-internal (or national) databases, ENUM-solutions fail on international ported numbers. Therefore this option is not preferred.

- b) IMSI-query as defined in TS 123.140 appendix H [2]: requires IMSI-information (using Send_IMSI or optionally SRI_for_SM) available in the originating network. For this solution an additional database mapping MCC and MNC to MMSC-domain names is required.

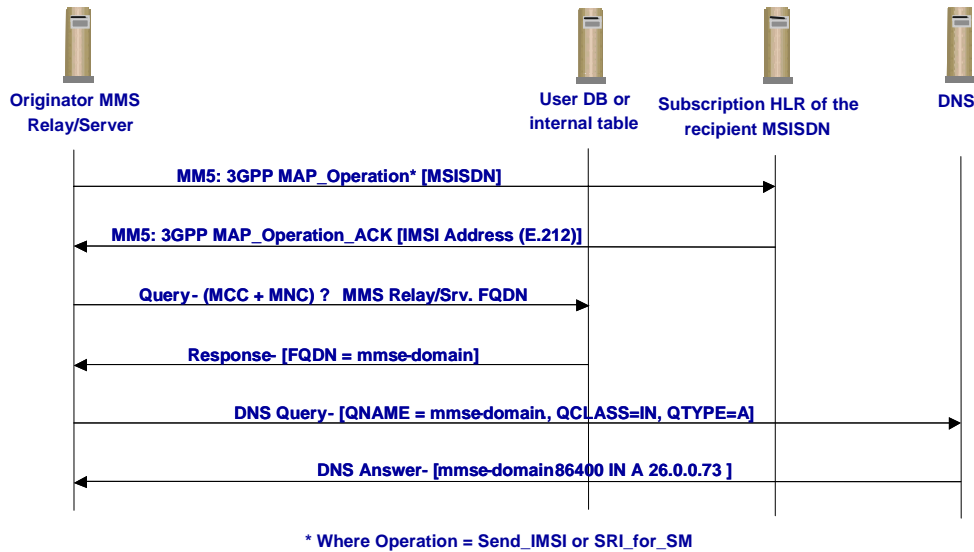

Figure 11: Message flow of the recipient MSISDN address resolution based on IMSI [2]

When the originating network operator does not take into account number portability (e.g. international traffic), indirect routing can be applied, i.e. the message is sent to the network associated with the numbering range (the network the not ported number would be assigned to), that number range holder network then relay (forward) the message to the subscription network.

4.6 Interworking with Fixed Network MMS

Originally MMS was targeting mobile devices, but in the meantime a standard for fixed line MMS has been created by ETSI [3]. In the fixed network PPP (instead of WSP) and fixed network SMS are used to provide the MMS service to the end-user, see figure 12.

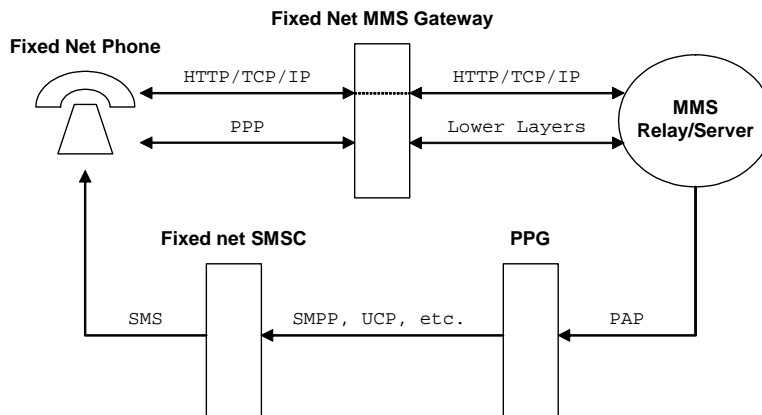

Figure 12: General MM1 gateway structure for fixed networks[3]

4.7 MM7: Value Added Services

Reference point MM7 is used to transfer MMs from MMS Relay/Server to MMS VAS applications and to transfer MMs from MMS VAS applications to MMS Relay/Server. This reference point is based on SOAP 1.1 and SOAP messages with attachments using an HTTP transport layer.

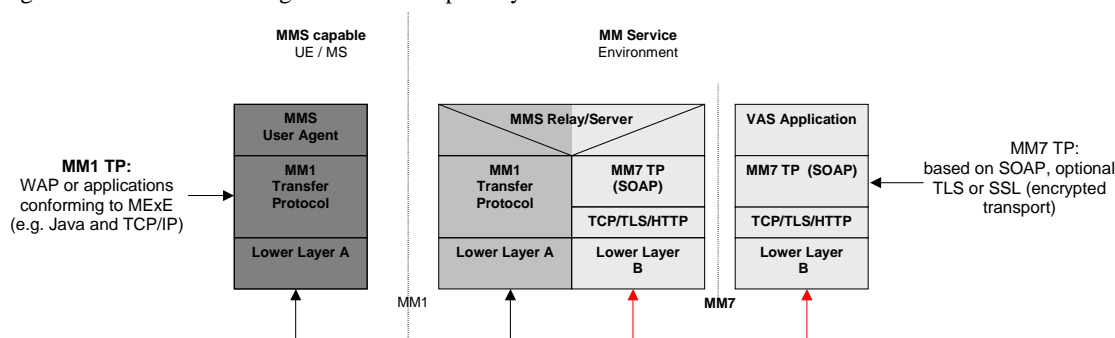

Figure 13: MM7 Service Environment, mapping to MM1

MMS Relay/Server receives multimedia message from MM1, MM3, MM4 or MM7 Reference points before routing forward message to the VASP. Messages originated from the VASP may be targeted to the recipient via MM1, MM3, MM4 or MM7 Reference points.

5 INTERCONNECTION

5.1 Current status

While an any-to-any functionality is essential for MMS to evolve, it took rather a long time before interconnection for MMS became available. When the service was introduced the main focus was on solving interworking problems between mobile phones of different manufacturers - and also between different models of the same brand. Also MMSCs had problems with poorly formatted MMs received from mobiles and technical problems in communication between MMSCs were another reason for delays - manufacturers interpreted relevant standards differently, which lead to interworking failures.

Today MMS interconnection is still far behind SMS or voice interconnection. Interconnection is based on the MM4 protocol, which can be described as SMTP (the standard protocol for Internet mail exchange) plus some MMS-specific extensions.

A simple approach would be to use the public Internet to interconnect the MMSCs as it is used for SMTP in ordinary email today. For quality, security and billing reasons providers chose not to use the "net" as it is, but to set up a separate network. This new network can either use dedicated lines or the Internet as a carrier network.

National interconnection has had top priority and has been established by most operators who offer MMS to their customers. As the number of networks involved is limited (typically between 3 and 6), a direct interconnection is still efficient, but also GRXes can be used.

International interconnection is developing slowly, influenced by the view that the market potential for sending international MMS is low. The reason is that users who want to send a holiday-picture home require GPRS interconnection but not MMSC-interconnection, as the MMS is sent from the roaming user direct to the home-network-MMSC, not to the MMSC of the visited network. International interconnection at the MMS level is needed only to send MMs to the mobiles of customers of a foreign network. International interconnection at the MMS level is likely to use GRXs.

5.2 Interconnection Billing

According to industry sources interconnection billing has not yet started, mainly due to technical problems and to the low number of MMS exchanged. MMs are exchanged on a peering basis without payment.

Interconnection billing systems might be based on:

- number of messages exchanged (fee per message),
- volume transferred (fee per kByte),
- type of message (content based billing, eg. picture, sound, video-clip, ...) or
- class of message (eg. below 30 kByte, 30-100kByte...).

Operators report problems measuring the size of an MM. The methods for determining the size of a MMs differ, some seem to include header fields, some use the raw size of the content, some meter the encoded size, especially on small MMS the difference can be up to 50%. The MMS-standard TS 23.140 [2] contains an informative annex C stating CDRs may be generated and the size may be included, but does not give guideline on how to calculate the correct size of a MMS.

Some sources [5] suggest using GRXs for interconnection and centralising billing facilities at these GRXs.

6 END-USER BILLING

Users are familiar with per-message billing as used by SMS. However, a per-byte-approach has been chosen for mobile packet data and a per-minute-approach for mobile circuit-switched data.

Operators have adopted the following charging principles for MMS:

- Sender pays for MMS (calling party pays, recipient does not pay)
- Event-type charge (charge per message, no extra charge for transfer)
- Some operators differentiate volume classes.

Typically the end user tariff for MMS is approximately twice the price for a SMS, usually around 0,50 EUR.

A typical technical implementation is to use a exclusive GPRS Access Point Name for MMS, e.g. mms.operator.net which is only charged per message (through MMSC), but not charged for the data transferred. Access is therefore limited to the MMSC. Usually further Access Point Names exist for "WAP" (normal WAP-access), "WEB" (internet access) and for corporate VPNs.

ANNEX A: ABBREVIATIONS

For the purposes of the present document, the following abbreviations apply:

APN	Access Point Name
CSCF	Call Session Control Function
CSD	Circuit Switched Data
DNS	Domain Name System
ENUM	Electronic Numbering (telephone number URI mapping)
ETSI	European Telecommunications Standards Institute
GPRS	General Packet Radio Services
GRX	GPRS eXchange
GSM	Global System for Mobile communications
HLR	Home Location Register
ICANN	Internet Corporation for Domain Names and Numbers
IMSI	International Mobile Subscriber Identity
IP	Internet Protocol
IPsec	Security architecture for IP (RFC 2401)
ISDN	Integrated Services Digital Network
MM	Multimedia Message
MMS	Multimedia Messaging Service
MMSC	MMS Centre
MMSE	Multimedia Messaging Service Environment
MSISDN	Mobile Station International ISDN Number
PLMN	Public Land Mobile Network
SMS	Short Message Service
SMTP	Short Message Transfer Protocol
SOAP	Simple Object Access Protocol
SS7	Signalling System Nr. 7
TLD	Top Level Domain
UMS	Unified Messaging Service
UMTS	Universal Mobile Telecommunications System
VAS	Value Added Services
VPN	Virtual Private Network
WAP	Wireless Application Protocol