



US 20130277759A1

(19) **United States**

(12) **Patent Application Publication**  
**Chen et al.**

(10) **Pub. No.: US 2013/0277759 A1**

(43) **Pub. Date: Oct. 24, 2013**

(54) **SEMICONDUCTOR FIN STRUCTURES AND METHODS FOR FORMING THE SAME**

**Publication Classification**

(51) **Int. Cl.**  
*H01L 29/06* (2006.01)  
*H01L 21/762* (2006.01)  
*H01L 27/088* (2006.01)

(52) **U.S. Cl.**  
 USPC ..... *257/397*; *257/506*; *438/424*; *257/E29.02*;  
*257/E27.06*; *257/E21.546*

(75) Inventors: **Ryan Chia-Jen Chen**, Chiaya (TW);  
**Yih-Ann Lin**, Jhudong Township (TW);  
**Chia Tai Lin**, Taichung City (TW);  
**Chao-Cheng Chen**, Hsin-Chu (TW)

(73) Assignee: **Taiwan Semiconductor Manufacturing Company, Ltd.**, Hsin-Chu (TW)

(57) **ABSTRACT**  
 A device includes a semiconductor substrate, and a plurality of semiconductor fins parallel to each other, wherein the plurality of semiconductor fins is a portion of the semiconductor substrate. A Shallow Trench Isolation (STI) region is on a side of the plurality of semiconductor fins. The STI region has a top surface and a non-flat bottom surface, wherein the plurality of semiconductor fins is over the top surface of the STI region.

(21) Appl. No.: 13/452,516

(22) Filed: **Apr. 20, 2012**

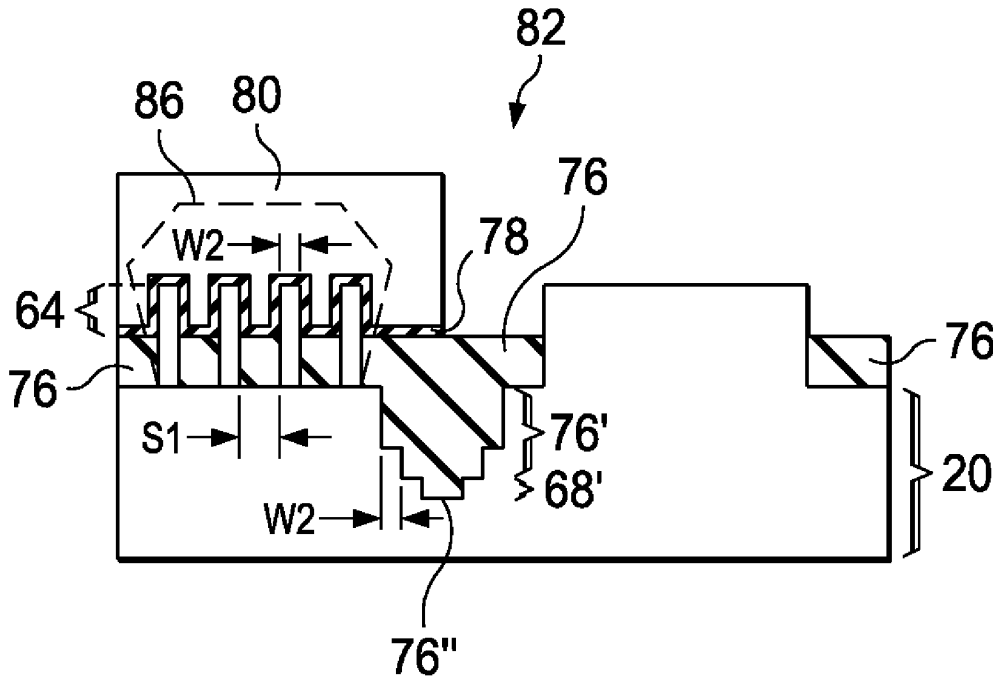

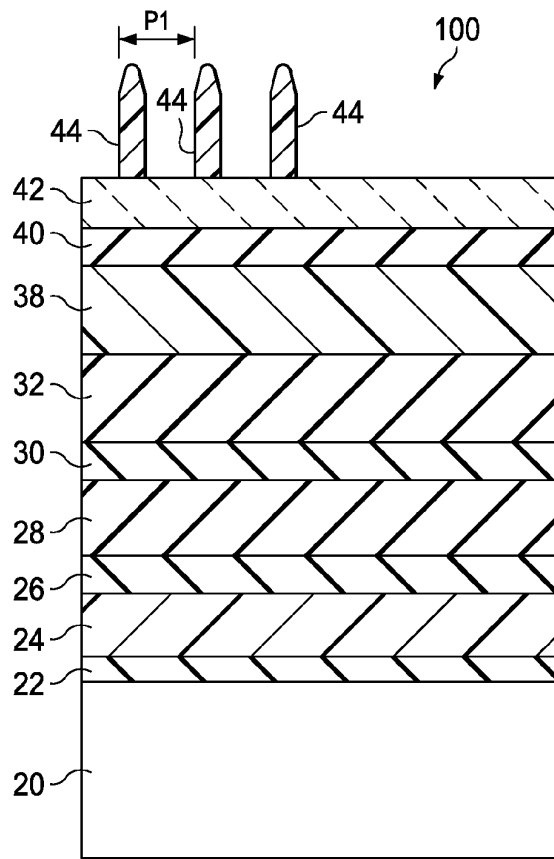

FIG. 1

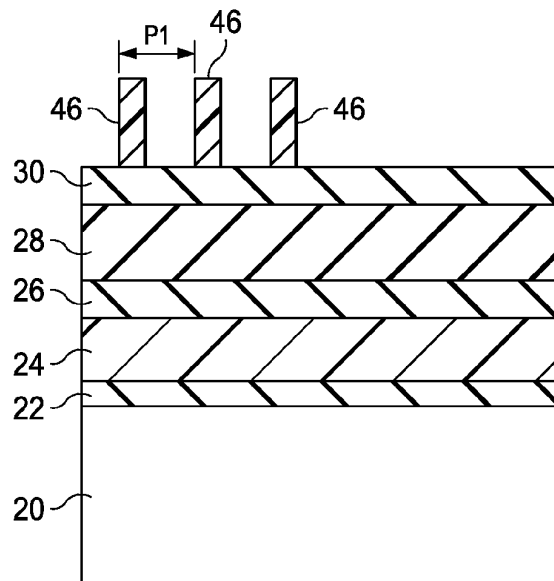

FIG. 2

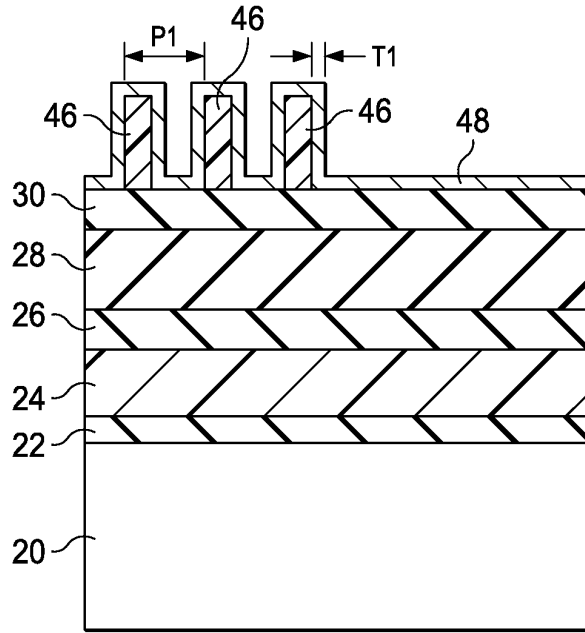

FIG. 3

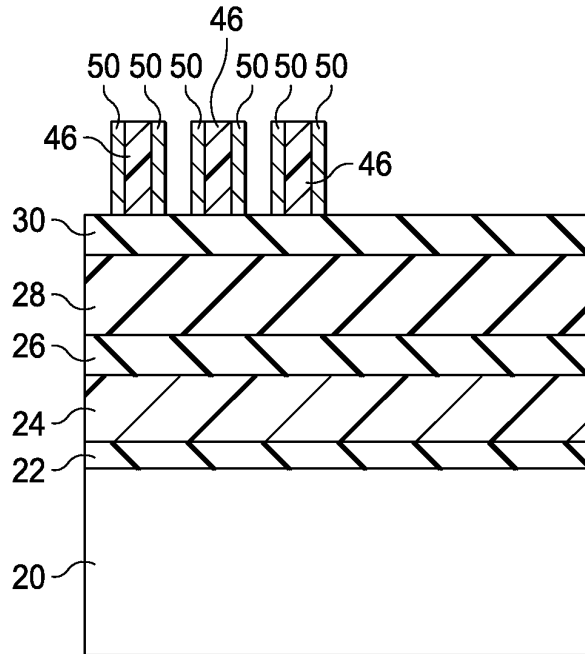

FIG. 4

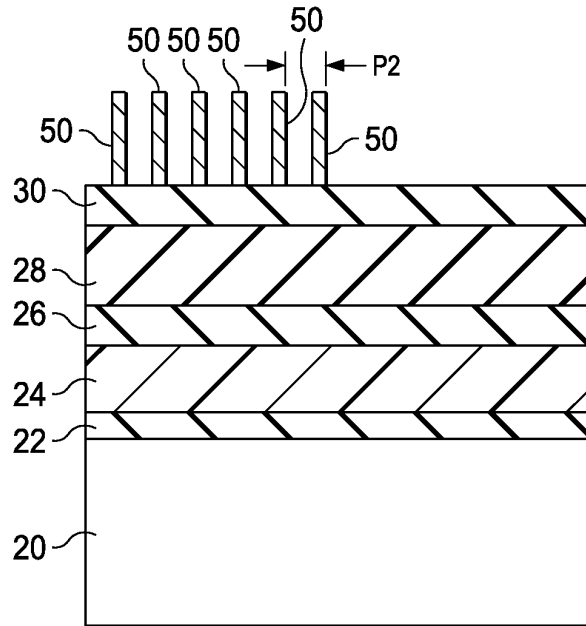

FIG. 5

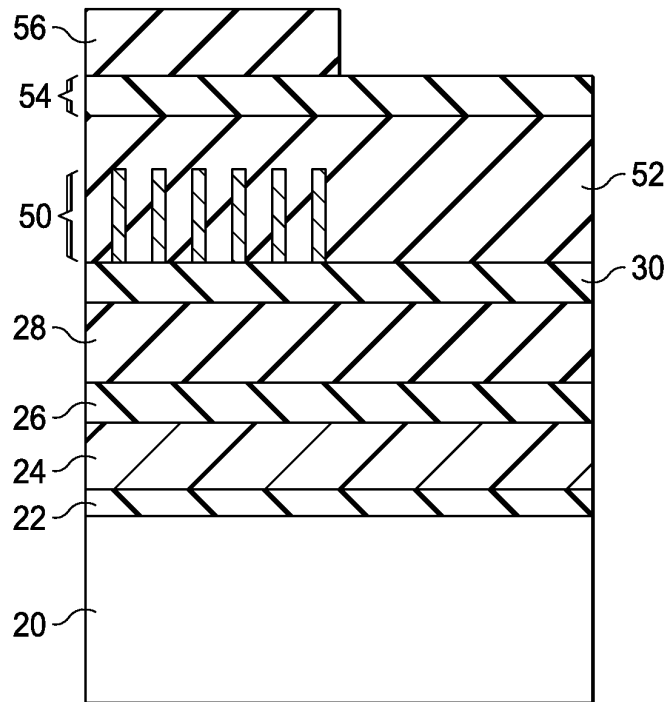

FIG. 6

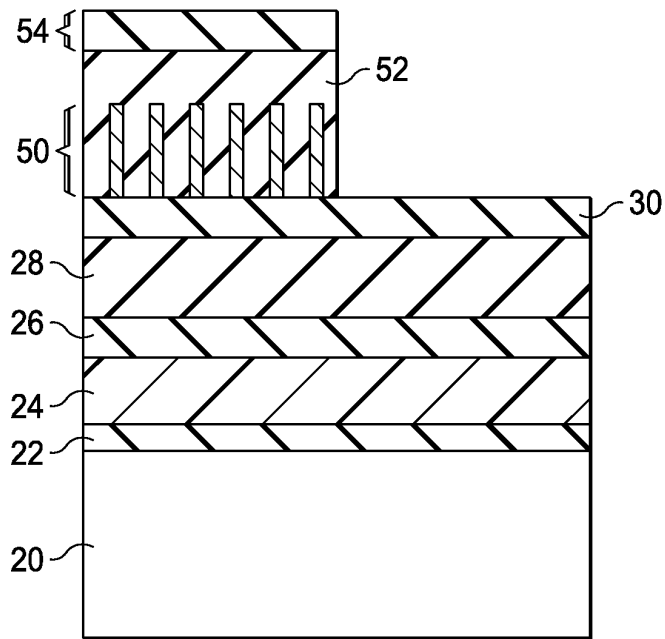

FIG. 7A

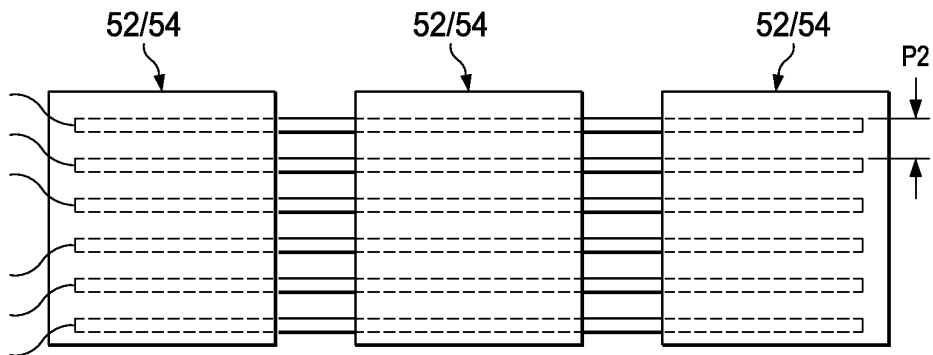

FIG. 7B

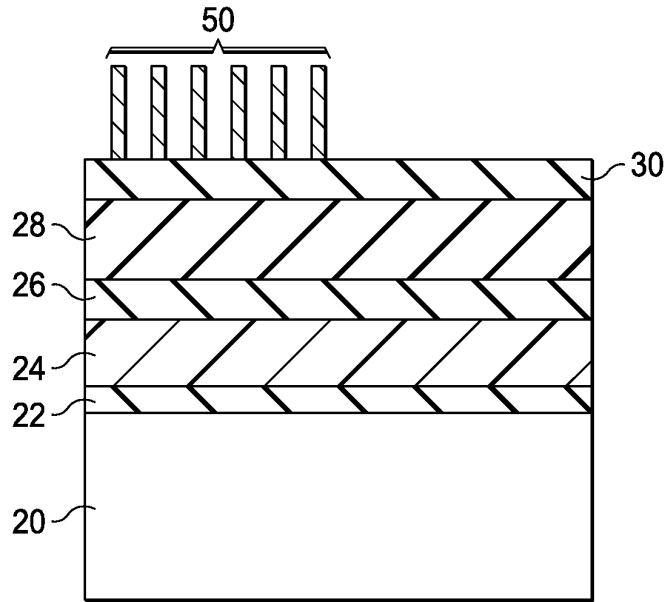

FIG. 8A

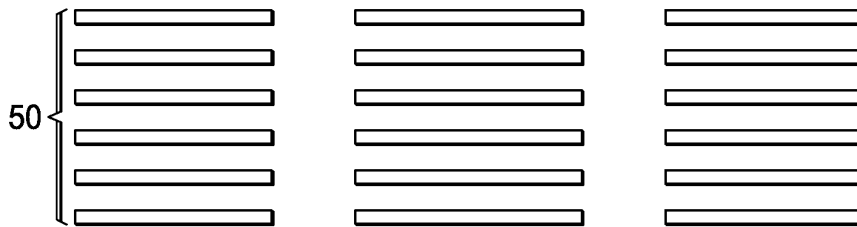

FIG. 8B

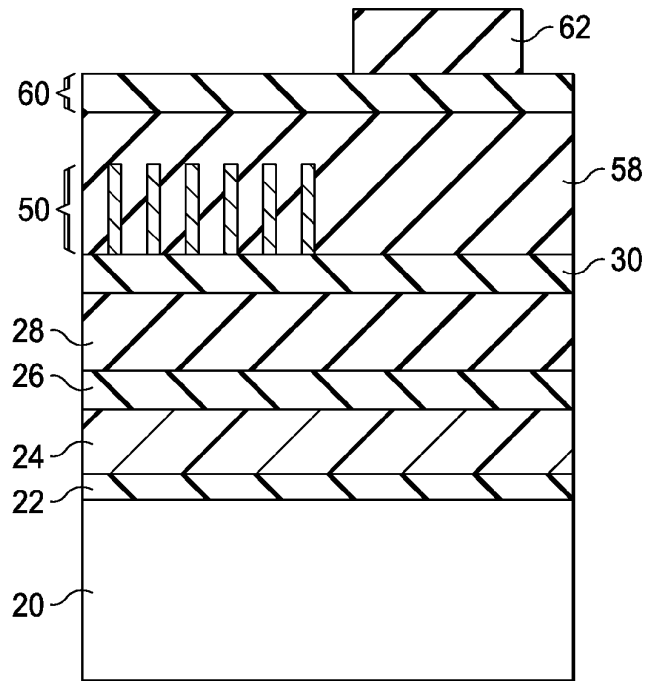

FIG. 9

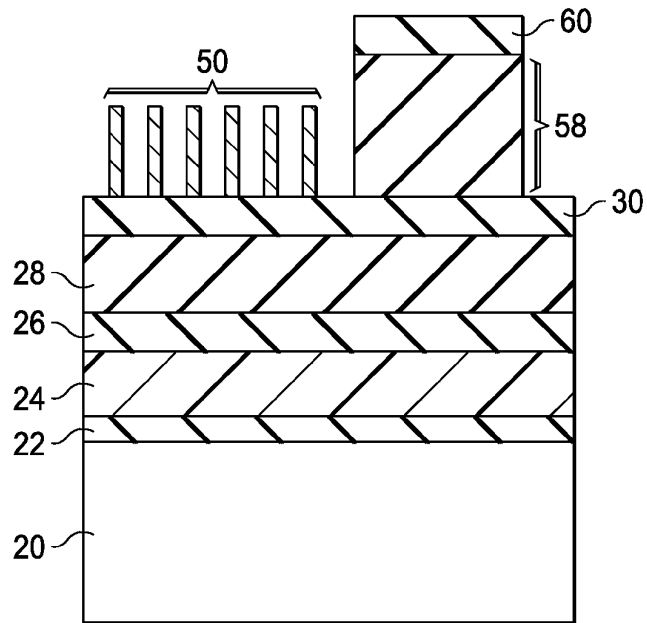

FIG. 10

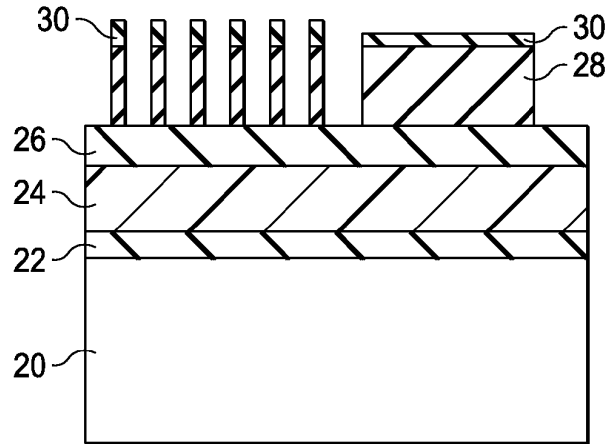

FIG. 11

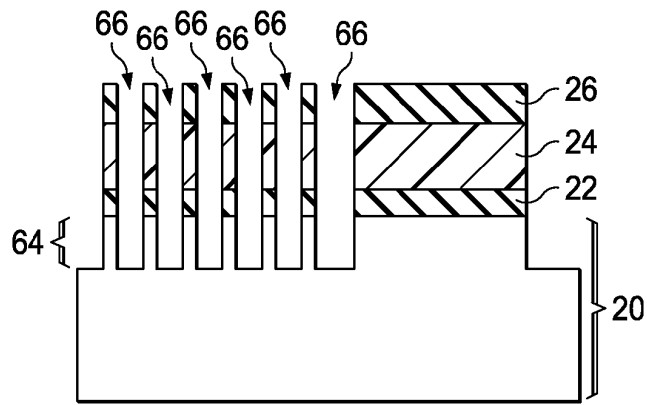

FIG. 12

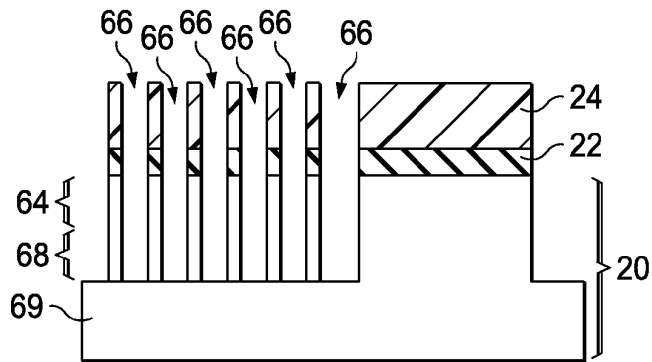

FIG. 13

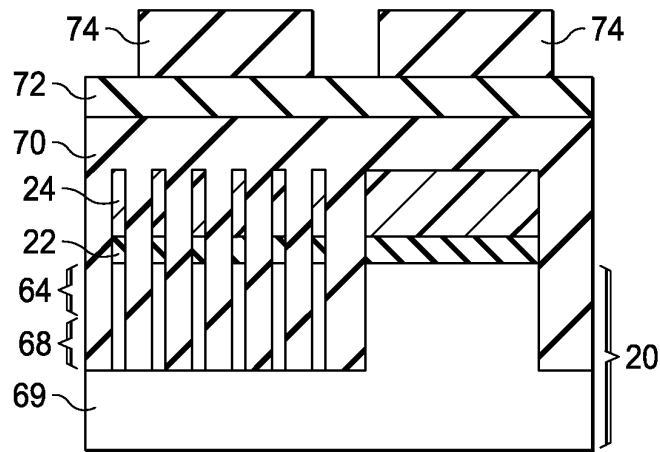

FIG. 14

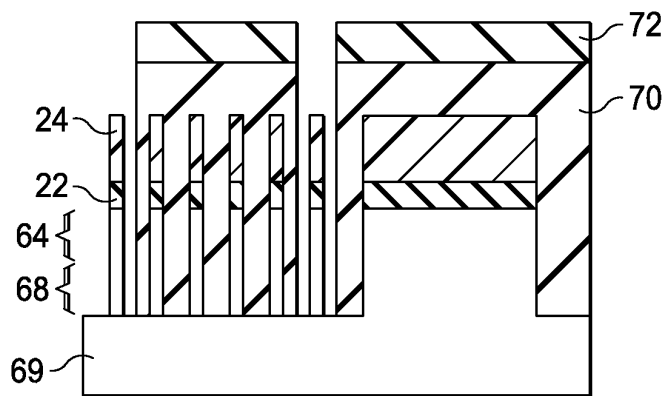

FIG. 15

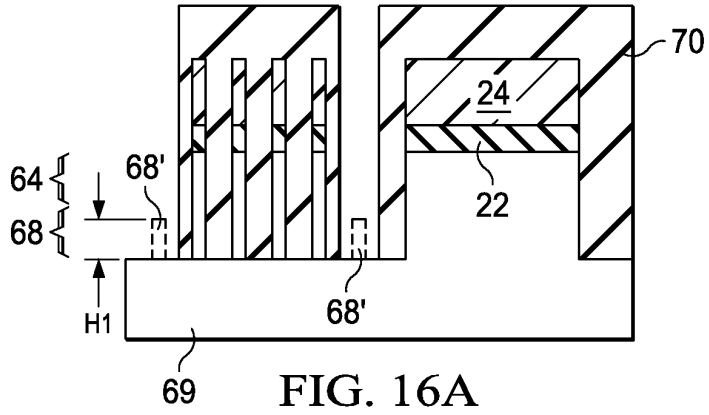

FIG. 16A

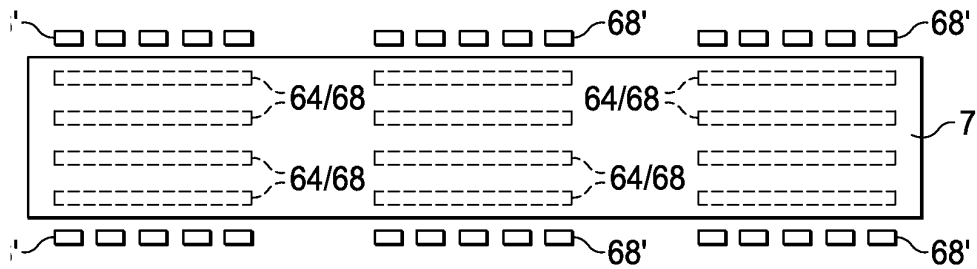

FIG. 16B

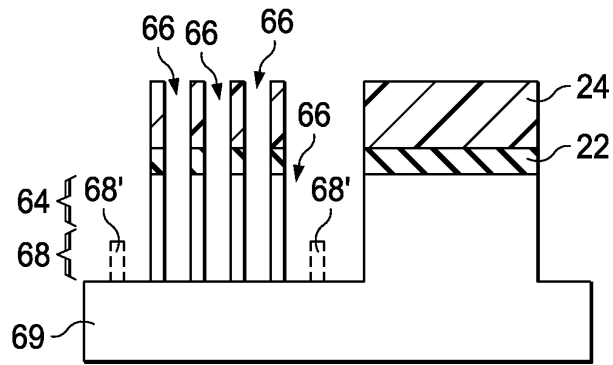

FIG. 17A

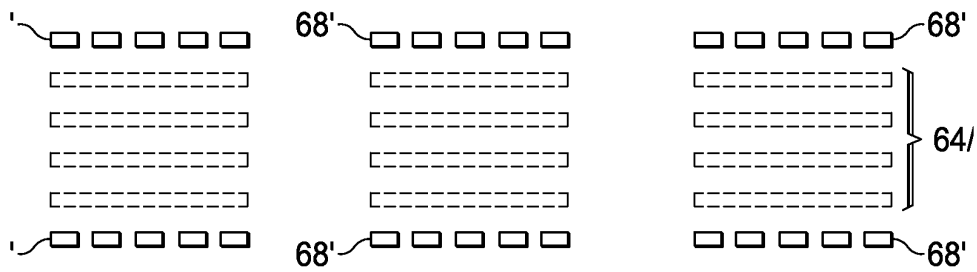
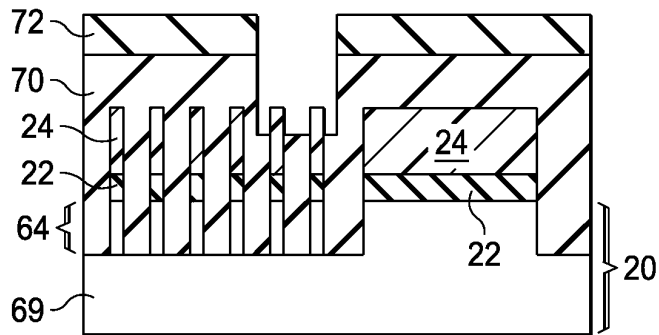
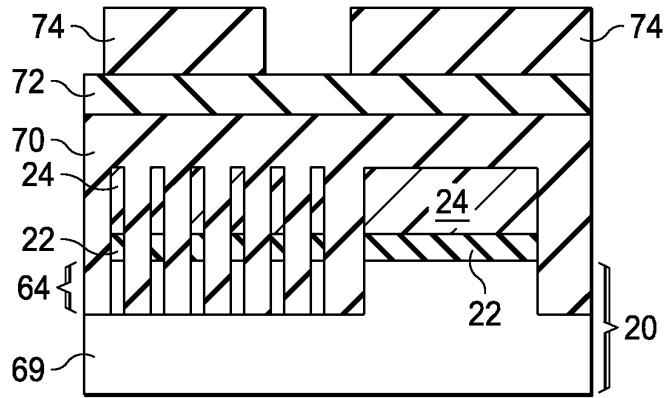
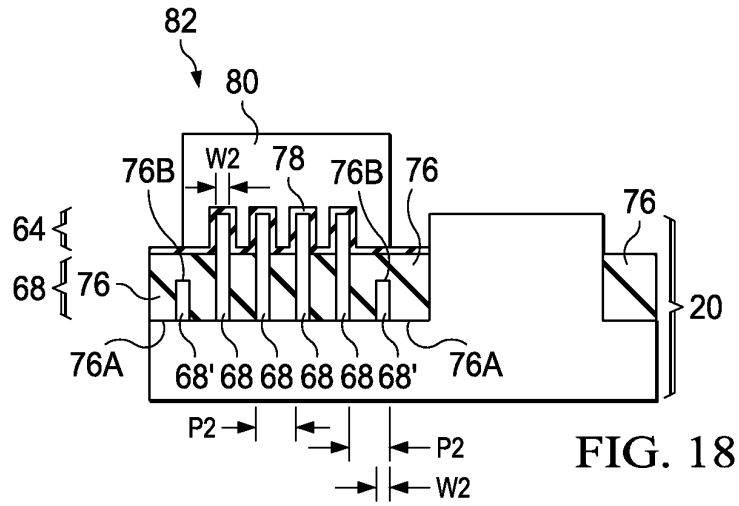

FIG. 17B



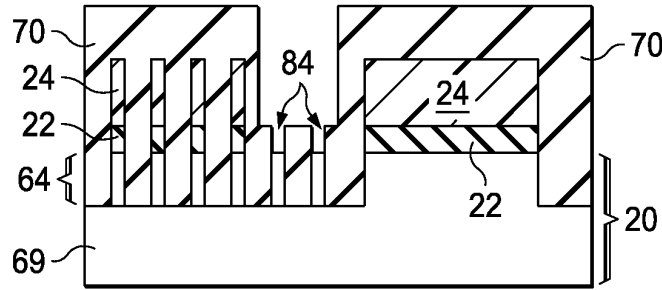

FIG. 21

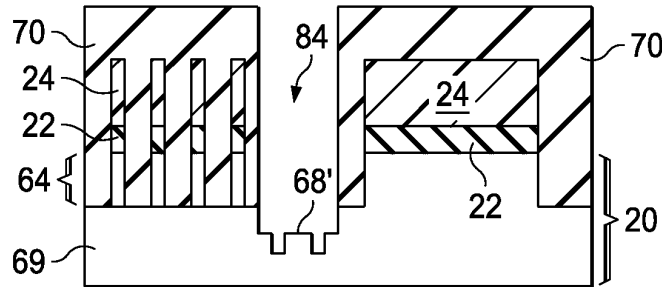

FIG. 22

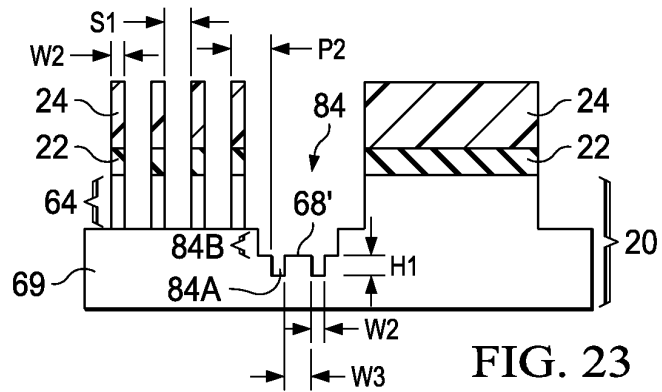

FIG. 23

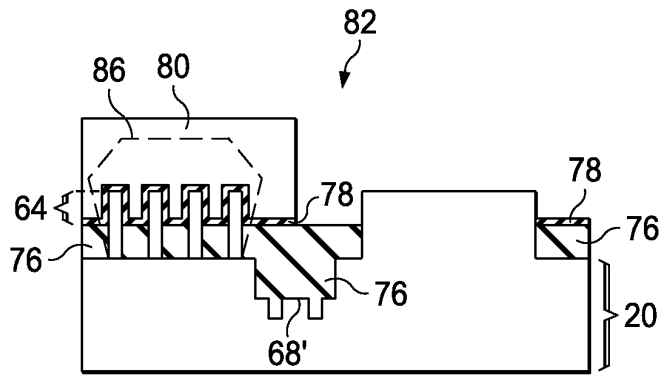

FIG. 24A

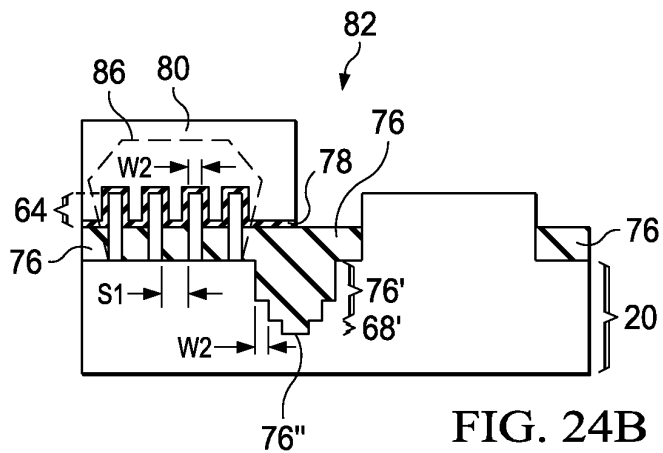

FIG. 24B

## SEMICONDUCTOR FIN STRUCTURES AND METHODS FOR FORMING THE SAME

### BACKGROUND

**[0001]** With the increasing down-scaling of integrated circuits and the increasingly demanding requirements to the speed of integrated circuits, transistors need to have higher drive currents with smaller dimensions. Fin Field-Effect Transistors (FinFET) were thus developed. FinFETs have increased channel widths. The increase in the channel width is achieved by forming channels that include portions on the sidewalls of the fins and portions on the top surfaces of the fins.

**[0002]** With the increasing down-scaling of integrated circuits, fins also become increasingly thinner, and the aspect ratios of the gaps between the fins become increasingly greater. The formation processes of the fins thus are more prone to the process variations in the respective manufacturing processes. In conventional FinFET manufacturing processes, the hard masks for forming the fins are defined first. The hard masks are then used as etching masks to etch the underlying semiconductor substrates, and the patterns of the hard masks are transferred to the underlying semiconductor substrates to form fins. In the etching of the semiconductor substrates, since the hard masks have pattern-dense regions and pattern-sparse regions, the pattern loading effect causes the fins in the pattern-dense regions and the pattern-sparse regions to be different from each other. The respective FinFETs are thus adversely affected.

### BRIEF DESCRIPTION OF THE DRAWINGS

**[0003]** For a more complete understanding of the embodiments, and the advantages thereof, reference is now made to the following descriptions taken in conjunction with the accompanying drawings, in which:

**[0004]** FIGS. 1 through 18 are cross-sectional views of intermediate stages in the manufacturing of Fin Field-Effect Transistors (FinFET) in accordance with some exemplary embodiments; and

**[0005]** FIGS. 19 through 24B are cross-sectional views of intermediate stages in the manufacturing of FinFETs in accordance with some alternative embodiments.

### DETAILED DESCRIPTION OF ILLUSTRATIVE EMBODIMENTS

**[0006]** The making and using of the embodiments of the disclosure are discussed in detail below. It should be appreciated, however, that the embodiments provide many applicable inventive concepts that can be embodied in a wide variety of specific contexts. The specific embodiments discussed are illustrative, and do not limit the scope of the disclosure.

**[0007]** A method of forming semiconductor fins, which may be used for forming Fin Field-Effect Transistors (FinFETs), and the respective structures are provided in accordance with various exemplary embodiments. The intermediate stages of forming the semiconductor fins are illustrated. The variations of the embodiments are discussed. Throughout the various views and illustrative embodiments, like reference numbers are used to designate like elements.

**[0008]** FIGS. 1 through 18 illustrate cross-sectional views of intermediate stages in the formation of semiconductor fins, isolation regions, and FinFETs in accordance with various

embodiments. FIG. 1 illustrates wafer 100, which includes substrate 20 and overlying layers. Substrate 20 may be formed of a semiconductor material such as silicon, silicon germanium, or the like. In some embodiments, substrate 20 is a crystalline semiconductor substrate such as a crystalline silicon substrate. Pad oxide layer 22 and hard mask 24 are formed over substrate 20. In accordance with embodiments, pad oxide layer 22 comprises silicon oxide. Hard mask 24 may be formed of silicon nitride.

**[0009]** A plurality of layers is formed over hard mask 24. In some exemplary embodiments, the plurality of layers includes oxide layers 26 and 30, hard masks 28, 32, and 38, silicon oxynitride layer 40, and Bottom Anti-Reflective Coating (BARC) 42. It is appreciated that the layers illustrated in FIG. 1 is exemplary. In alternative embodiments, different layers may be formed over substrate 20, and the number of layers may also be different from what is shown in FIG. 1. Oxide layers 26 and 30 may be Plasma Enhanced (PE) oxides, which may be silicon oxide layers that are formed using Plasma Enhanced Chemical Vapor Deposition (PECVD). Hard mask 28 and 32 may comprise an Ashing Removable Dielectric (ARD) material, and hence is referred to as ARDs 28 and 32 hereinafter, although they may also be formed of other materials. In some embodiments, hard mask 38, which may also be an ARD, may include amorphous carbon. Silicon oxynitride layer 40 may be formed over hard mask 38. BARC 42 and silicon oxynitride layer 40 may be used for lithography purposes, for example, for reducing the reflection of the yellow light used in the exposure of the overlying photo resist 44.

**[0010]** FIGS. 1 and 2 also illustrate a lithography process for patterning ARD 32. Photo resist 44 is formed over BARC 42, and is then patterned. Layers 32, 38, 40, 42, and photo resist 44 are used to form patterns with small pitches, which may be less than the minimum pitch allowed by the lithography process used for forming the integrated circuits. Layers 22, 26, 28, and 30 are used to transfer the small pitches to substrate 20. In some embodiments, the minimum pitch P1 of photo resist 44 may be close to, or equal to, the minimum pitch allowed by the technology for developing photo resist 44 and for performing the etch using photo resist 44 as an etching mask.

**[0011]** BARC 42, silicon oxynitride layer 40, and ARDs 38 and 32 are etched, for example, using plasma-assisted dry etching, followed by the removal of photo resist 44, BARC 42, and layers 40 and 38. The resulting structure is shown in FIG. 2. The remaining portions of hard mask 32 are referred to as mandrels 46 hereinafter. The pitches of mandrels 46 may be substantially equal to the respective pitch P1 of photo resist 44 (FIG. 1).

**[0012]** Next, as shown in FIG. 3, spacer layer 48 is deposited using a conformal deposition method. In some embodiments, spacer layer 48 is deposited using Atomic Layer Deposition (ALD), which may form a high quality film that has a low etching rate. The ALD may be performed using DiChloroSilane (DCS) and ammonia as precursors, and the resulting spacer layer 48 may include silicon nitride or silicon-rich nitride. In alternative embodiments, other conformal deposition methods, such as Low-Pressure Chemical Vapor Deposition (LPCVD), may be performed. Thickness T1 of spacer layer 48 may be less than a half of, and may be close to about a third of, pitch P1 of mandrels 46 in some exemplary embodiments.

**[0013]** Referring to FIG. 4, the horizontal portions of spacer layer 48 are removed, for example, through an aniso-

tropic etching step. The vertical portions of spacer layer 48 are left, and are referred to as spacers 50 hereinafter. Next, as shown in FIG. 5, mandrels 46 are removed in an etching step, and spacers 50 remain. Pitches P2 of spacers 50 may be a half of pitch P1 in FIG. 1. In some embodiments, pitch P2 is smaller than the minimum pitch.

[0014] FIGS. 6 through 8B illustrate the first patterning process of spacers 50. Referring to FIG. 6, bottom layer 52 is formed over spacers 50. Bottom layer 52 may contain a photo resist. Middle layer 54 is then formed over bottom layer 52. Middle layer 54 may be formed of an oxide-like photo resist, although other materials may be used. Bottom layer 52 and middle layer 54 may be formed using spin-on coating. Following the formation of middle layer 54, photo resist 56 is formed and patterned.

[0015] Middle layer 54 and bottom layer 52 are patterned according to the pattern of photo resist 56. Photo resist 56 is then removed. The resulting structure is shown in FIGS. 7A and 7B. FIG. 7A illustrates a cross-sectional view and FIG. 7B illustrates a top view. It is illustrated that spacers 50 include a plurality of strips that are parallel to each other. The strips 50 may have a uniform pitch P2. The patterned bottom layer 52 and middle layer 54 form masks that cover portions of spacers 50, while some other portions of spacers 50 are not covered.

[0016] In FIGS. 8A and 8B, which are a cross-sectional view and a top view, respectively, the exposed portions of spacers 50 that are not covered by bottom layer 52 and middle layer 54 are removed. Accordingly, spacers 50 are cut into a plurality of separate shorter strips. Bottom layer 52 and middle layer 54 are then removed.

[0017] FIGS. 9 and 10 illustrate the patterning of an additional pattern that is used to etch substrate 20, which pattern may have a greater width than the widths of spacers 50. Referring to FIG. 9, bottom layer 58 and middle layer 60 are formed, and photo resist 62 is formed over layers 58 and 60, and then patterned. Bottom layer 58 and middle layer 60 are then patterned, as shown in FIG. 10. Photo resist 62 is then removed. Next, as shown in FIG. 11, hard mask layer 28 is etched using spacers 50 and the patterned bottom layer 58 and middle layer 60 as an etching mask. The patterns of spacers 50 and the patterned bottom layer 58 and middle layer 60 are thus transferred into hard mask 28.

[0018] Next, hard mask 28 is used as an etching mask to etch underlying layers including pad oxide layer 22, silicon nitride layer 24, and PE oxide layer 26. Substrate 20 is also etched. Hard mask 28 is then removed, and the resulting structure is shown in FIG. 12. The portions of substrate 20 underlying spacers 50 (FIG. 10) form semiconductor fins 64. Recesses 66 are also formed in substrate 20, and separate semiconductor fins 64 from each other. Semiconductor fins 64 include two edge fins, and inner fins between the edge fins. The inner fins 64 have substantially the same width W2 (critical dimension, also see width W2 in FIG. 23) as the edge fins 64. Furthermore, the profiles of the inner fins 64 are substantially the same as that of edge fins 64, wherein the profiles may include for example, shapes, the tilt angles of edges, and the like.

[0019] Next, as shown in FIG. 13, substrate 20 is further etched to extend recesses 66 downwardly. This step may be referred to as Shallow Trench Isolation (STI) etching since the extended portions of recesses 66 that are formed in this step will be filled to form STI regions later, while the portions of fins 64 formed in the step in FIG. 12 may be used to form

the fins of FinFETs. The portions of substrate 20, which form strips between the extended portions of recesses 66, are referred to as fin extensions 68 hereinafter, although fin extensions 68 are also parts of fins. At the same time fins 64 and fin extensions 68 are formed, large active region 69 is also formed.

[0020] FIGS. 14 through 17B illustrate second patterning process for the further patterning of fins 64. In FIG. 14, bottom layer 70 and middle layer 72 are formed, followed by the formation and the patterning of photo resist 74. Bottom layer 70 may be formed of a material similar to the material of bottom layer 52 (FIG. 6). Middle layer 72 may also be formed of a material similar to the material of middle layer 54. Next, as shown in FIG. 15, photo resist 74 is used as an etching mask to pattern bottom layer 70 and middle layer 72. In some embodiments, the patterned bottom layer 70 and middle layer 72 overlap large active region 69 and a first plurality of fins 64, and do not overlap a second plurality of fins 64. Photo resist 74 is then removed.

[0021] Next, as shown in FIG. 16A, the second plurality of fins 64 is removed, and the first plurality of fins 64 remains un-removed. In some embodiments, some bottom portions of fin extensions 68 also remain, and are referred to as fin extension residues 68' hereafter. The height H1 of the remaining fin extension residues 68' may be greater than about 50 Å in some embodiments, although height H1 may also be greater or smaller. FIG. 16B illustrates a top view of the structure shown in FIG. 16A, wherein fin extension residues 68' are illustrated using dashed lines. Next, as shown in FIGS. 17A and 17B, which illustrate a cross-sectional view and a top view, respectively, the patterned bottom layer 70 and middle layer 72 are removed.

[0022] Referring to FIG. 18, isolation regions such as STI regions 76 are filled into recesses 66, and then recessed. A Chemical Mechanical Polish (CMP) is performed to level the top surface of STI regions 76. STI regions 76 have bottom surfaces 76A substantially level with each other. Fin extension residues 68' may extend into edge STI regions 76 from the bottom surfaces of the edge STI regions 76. Furthermore, the top surfaces of fin extension residues 68' may contact bottom surfaces 76B of the edge STI region 76. The remaining portions of layers 22 and 24 are also removed.

[0023] As also shown in FIG. 18, FinFET 82 is formed on fins 64. FinFET 82 includes gate dielectric 78 and gate electrode 80. In the resulting structure, it is observed that fin extension residues 68' extend up into edge STI regions 76, and are encircled by edge STI regions 76. It is also observed that pitch P2 of fin extension residues 68' and its neighboring fin 64 may be the same as pitch P2 between neighboring fin extensions 68. Furthermore, widths W2 of fin extensions 68 may be substantially the same as widths W2 of fin extension residues 68'.

[0024] FIGS. 19 through 24B illustrate cross-sectional views of intermediate stages in the formation of fins and FinFETs in accordance with alternative embodiments. Unless specified otherwise, the materials and formation methods of the components in these embodiments are essentially the same as the like components, which are denoted by like reference numerals in the embodiments shown in FIGS. 1 through 18. The formation details of the embodiments shown in FIGS. 19 through 24B may thus be found in the discussion of the embodiments shown in FIGS. 1 through 18.

[0025] The initial steps of these embodiments are essentially the same as shown in FIGS. 1 through 12. In a subse-

quent step as in FIG. 19, the STI etch as shown in FIG. 13 is skipped. Instead, bottom layer 70 and middle layer 72 are formed, followed by the formation of photo resist 74. Next, as shown in FIG. 20, photo resist 74 is used as an etching mask to pattern bottom layer 70 and middle layer 72. In some embodiments, the patterned bottom layer 70 and middle layer 72 overlap large active region 69 and a first plurality of fins 64, and do not overlap a second plurality of fins 64. Photo resist 74 is then removed. In subsequent steps as shown in FIGS. 20 and 21, bottom layer 70 and middle layer 72 are used as an etching mask to etch portions of layers 22 and 24 that are not covered, until the second plurality of fins 64 is exposed. Next, as shown in FIGS. 21 and 22, the second plurality of fins 64 is etched. In some embodiments, at the same time the second plurality of fins 64 is etched, bottom layer 70 and middle layer 72 are also etched, so that recess 84 is formed in substrate 20. Bottom layer 70 and middle layer 72 are then removed, and the resulting structure is shown in FIG. 23.

[0026] Referring to FIG. 23, fin extension residue 68' is formed as a result of the etching, and extends into recess 84 from bottom. Recess 84 includes portions 84A on opposite sides of fin extension residue 68'. Recess 84 further includes portion 84B over and joined to portions 84A, wherein the bottom surface of portion 84B is higher than the bottom surface of portions 84A. One of recess portions 84A may have pitch P2 from the nearest fin 64, which pitch may be the same as the pitch P2 of fins 64. Furthermore, the width W2 of recess portions 84A may be substantially the same as the width W2 of fins 64. In addition, width W3 of fin extension residue 68' may be substantially the same as fin spacing S1 between fins 64.

[0027] FIG. 24A illustrates the formation of FinFET 82, and the corresponding gate dielectric 78 and gate electrode 80. STI region 76 is also formed in recess 84 and then recessed. In the source and drain regions of FinFET 82, the epitaxially grown semiconductor region 86 merge with each other to form a crown-shaped region 86.

[0028] FIG. 24B illustrates FinFET 82 in accordance with alternative embodiments, wherein STI portions 76" (and the corresponding STI regions) are formed between fin extension residues 68'. STI portion 76" has a first bottom surface, whose bottom surface is lower than the bottom surface of STI portion 76'.

[0029] In FIGS. 18, 24A, and 24B, it is observed that STI regions 76 have non-flat bottom surfaces. Furthermore, the topography of the bottom surfaces of STI regions 76 reflects the patterns of spacers 50 (FIG. 5). Accordingly, the spacings and the widths of some portions of STI regions 76 are the same as the spacings and widths (such as S1, W2, W3, and the like), of respective spacers 50.

[0030] By using the embodiments, the semiconductor fins are patterned after their formation. Accordingly, since the dense and isolation regions, which are the results of the patterning, occur after the formation of fins 64, the pattern loading effect is avoided.

[0031] In accordance with embodiments, a device includes a semiconductor substrate, and a plurality of semiconductor fins parallel to each other, wherein the plurality of semiconductor fins is a portion of the semiconductor substrate. An STI region is on a side of the plurality of semiconductor fins. The STI region has a top surface and a non-flat bottom surface, wherein the plurality of semiconductor fins is over the top surface of the STI region.

[0032] In accordance with other embodiments, a device includes a semiconductor substrate, a plurality of STI regions in the semiconductor substrate, and a plurality of semiconductor fins parallel to each other and in the semiconductor substrate. A plurality of fin extensions is disposed underlying and aligned to the plurality of semiconductor fins, wherein the plurality of STI regions is disposed between the plurality of fin extensions. An edge STI region is disposed on a side of the plurality of fin extensions, wherein the edge STI region has a first bottom surface substantially level with bottom surfaces of the plurality of STI regions, and a second bottom surface higher than the first bottom surface. A fin extension residue has a bottom substantially level with bottoms of the plurality of fin extensions, wherein the fin extension residue extends into the edge STI region. A top surface of the fin extension residue is in contact with the second bottom surface of the edge STI region.

[0033] In accordance with yet other embodiments, a method includes forming a patterned mask including a plurality of strips, and etching a semiconductor substrate underlying the patterned mask to form a first and the second plurality of semiconductor fins. The patterned mask is used as an etching mask. The method further includes etching the second plurality of semiconductor fins without etching the first plurality of semiconductor fins. A recess is formed in the semiconductor substrate by the step of etching the second plurality of semiconductor fins. The recess is filled with a dielectric material to form an isolation region, wherein the first plurality of semiconductor fins is over a top surface of the isolation region.

[0034] Although the embodiments and their advantages have been described in detail, it should be understood that various changes, substitutions and alterations can be made herein without departing from the spirit and scope of the embodiments as defined by the appended claims. Moreover, the scope of the present application is not intended to be limited to the particular embodiments of the process, machine, manufacture, and composition of matter, means, methods and steps described in the specification. As one of ordinary skill in the art will readily appreciate from the disclosure, processes, machines, manufacture, compositions of matter, means, methods, or steps, presently existing or later to be developed, that perform substantially the same function or achieve substantially the same result as the corresponding embodiments described herein may be utilized according to the disclosure. Accordingly, the appended claims are intended to include within their scope such processes, machines, manufacture, compositions of matter, means, methods, or steps. In addition, each claim constitutes a separate embodiment, and the combination of various claims and embodiments are within the scope of the disclosure.

What is claimed is:

1. A device comprising:
  - a semiconductor substrate;
  - a plurality of semiconductor fins parallel to each other, wherein the plurality of semiconductor fins is a portion of the semiconductor substrate; and
  - a Shallow Trench Isolation (STI) region on a side of the plurality of semiconductor fins, wherein the STI region comprises a top surface and a non-flat bottom surface, and wherein the plurality of semiconductor fins is over the top surface of the STI region.

2. The device of claim 1 further comprising:  
 a plurality of STI regions in the semiconductor substrate;  
 a plurality of fin extensions underlying and aligned to the plurality of semiconductor fins, wherein sidewalls of the plurality of fin extensions are in contact with sidewalls of the plurality of STI regions; and  
 a fin extension residue having a bottom substantially level with bottom surfaces of the plurality of fin extensions, wherein the fin extension residue extends into the STI region from a bottom surface of the STI region.
3. The device of claim 2, wherein the plurality of fin extensions has a first pitch, and wherein the fin extension residue and a nearest one of the plurality of semiconductor fins have a second pitch substantially equal to the first pitch.
4. The device of claim 2, wherein the fin extension residue has a width substantially equal to a width of one of the plurality of fin extensions.
5. The device of claim 1, wherein the STI region comprises:  
 a first portion having a first bottom surface; and  
 a second portion and a third portion, wherein the second portion and the third portion comprise second bottom surfaces lower than the first bottom surface, and wherein the first and the second bottom surfaces are comprised in the non-flat bottom surface, and wherein the device further comprises a fin extension residue between the second and the third portions of the STI region.
6. The device of claim 5, wherein the second portion of the STI region and a nearest one of the plurality of semiconductor fins have a first horizontal spacing, and wherein two of the plurality of semiconductor fins have a second horizontal spacing substantially equal to the first horizontal spacing.
7. The device of claim 1, wherein the STI region comprises:  
 a first portion having a first bottom surface; and  
 a second portion comprising a second bottom surface higher than the first bottom surface, wherein the first and the second bottom surfaces are comprised in the non-flat bottom surface.
8. The device of claim 7, wherein one edge of the second portion of the STI region and an edge of a nearest one of the plurality of semiconductor fins have a first horizontal spacing, and wherein two of the plurality of semiconductor fins have a second horizontal spacing substantially equal to the first horizontal spacing.
9. A device comprising:  
 a semiconductor substrate;  
 a plurality of Shallow Trench Isolation (STI) regions in the semiconductor substrate;  
 a plurality of semiconductor fins parallel to each other and in the semiconductor substrate;  
 a plurality of fin extensions underlying and aligned to the plurality of semiconductor fins, wherein the plurality of STI regions is disposed between the plurality of fin extensions;  
 an edge STI region on a side of the plurality of fin extensions, wherein the edge STI region comprises a first bottom surface substantially level with bottom surfaces of the plurality of STI regions, and a second bottom surface higher than the first bottom surface; and  
 a fin extension residue having a bottom substantially level with bottoms of the plurality of fin extensions, wherein the fin extension residue extends into the edge STI region, and wherein a top surface of the fin extension residue is in contact with the second bottom surface of the edge STI region.
10. The device of claim 9, wherein the first bottom surface of the edge STI region comprises portions on opposite sides of the second bottom surface of the edge STI region.
11. The device of claim 9, wherein the edge STI region comprises portions encircling the fin extension residue.
12. The device of claim 9 further comprising:  
 a gate dielectric on sidewalls and top surfaces of the plurality of semiconductor fins; and  
 a gate electrode over the gate dielectric, wherein the gate electrode overlaps the edge STI region.
13. The device of claim 9, wherein the fin extension residue and a nearest one of the plurality of fin extensions have a pitch substantially equal to a pitch of the plurality of semiconductor fins.
14. The device of claim 9, wherein the fin extension residue has a width substantially equal to a width of one of the plurality of fin extensions.
15. A method comprising:  
 forming a patterned mask comprising a plurality of strips;  
 etching a semiconductor substrate underlying the patterned mask to form a first and a second plurality of semiconductor fins, wherein the patterned mask is used as an etching mask;  
 etching the second plurality of semiconductor fins without etching the first plurality of semiconductor fins, wherein a recess is formed in the semiconductor substrate by the step of etching the second plurality of semiconductor fins; and  
 filling the recess with a dielectric material to form an isolation region, wherein the first plurality of semiconductor fins is over a top surface of the isolation region.
16. The method of claim 15, wherein after the step of etching the second plurality of semiconductor fins, a portion of the second plurality of semiconductor fins is left to form a fin extension residue.
17. The method of claim 16, wherein after the isolation region is formed, the fin extension residue extends into the isolation region from a bottom surface of the isolation region.
18. The method of claim 16, wherein a top surface of the fin extension residue is lower than the top surface of the isolation region.
19. The method of claim 15, wherein the step of forming the patterned mask comprises:  
 forming mandrels over the semiconductor substrate;  
 forming a spacer layer on sidewalls and top surfaces of the mandrels; and  
 removing horizontal portions of the spacer layer, wherein vertical portions of the spacer layer form first portions of the patterned mask.
20. The method of claim 19, wherein the step of forming the patterned mask further comprises:  
 forming a bottom layer and a middle layer over the first portions of the patterned mask; and  
 patterning the bottom layer, wherein portions of the bottom layer and the middle layer overlapping the first portions of the patterned mask are removed, and a second portion of the bottom layer and the middle layer are left to form a second portion of the patterned mask.