



(19) **United States**

(12) **Patent Application Publication**

Huo et al.

(10) **Pub. No.: US 2005/0249177 A1**

(43) **Pub. Date: Nov. 10, 2005**

(54) **HYBRID WIRELESS COMMUNICATIONS SYSTEM**

(22) Filed: **May 10, 2004**

(75) Inventors: **David D. Huo**, Newton, NJ (US);  
**Farooq Ullah Khan**, Monmouth, NJ (US)

(51) **Int. Cl.<sup>7</sup> ..... H04B 7/216**

(52) **U.S. Cl. .... 370/342; 370/335**

**Publication Classification**

Correspondence Address:  
**WILLIAMS, MORGAN & AMERSON/LUCENT**  
**10333 RICHMOND, SUITE 1100**  
**HOUSTON, TX 77042 (US)**

(57) **ABSTRACT**

A method that employs aspects of CDMA and OFDM modulation for controlling transmissions between a mobile station and a base station is provided. The method comprises forming a frame having a plurality of slots therein and then using CDMA modulation in a first portion of the plurality of slots, and using OFDM modulation in a second portion of the plurality of slots.

(73) Assignee: **Lucent Technologies, Inc.**

(21) Appl. No.: **10/842,701**

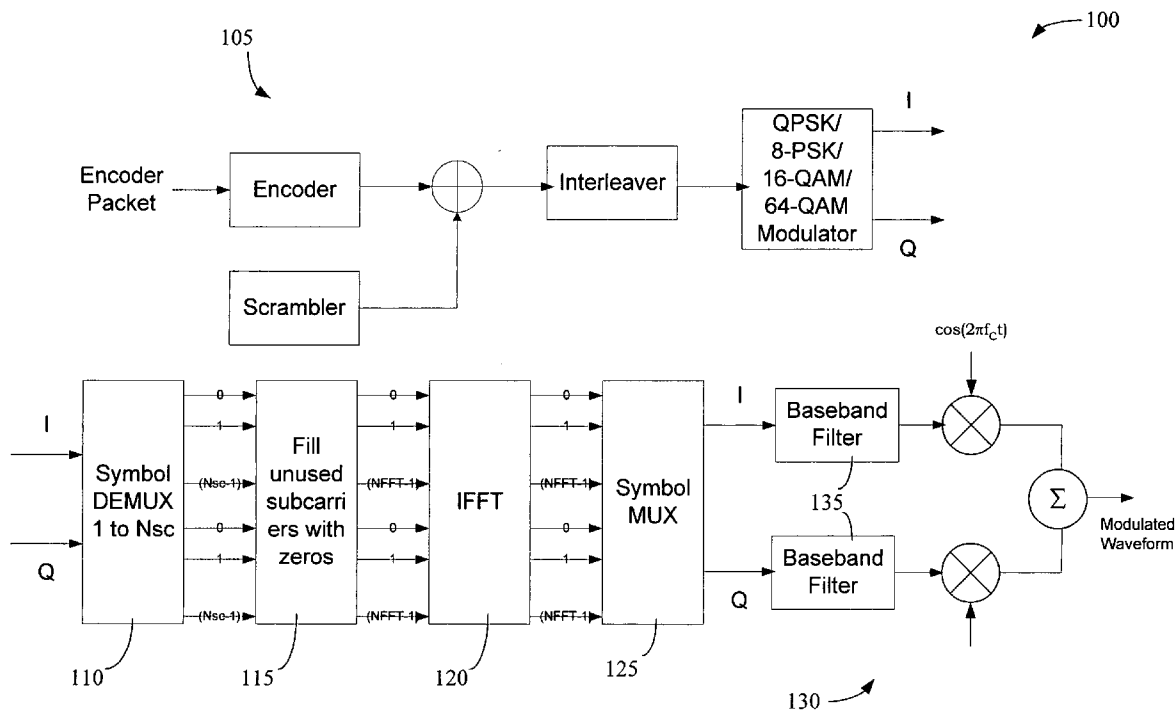

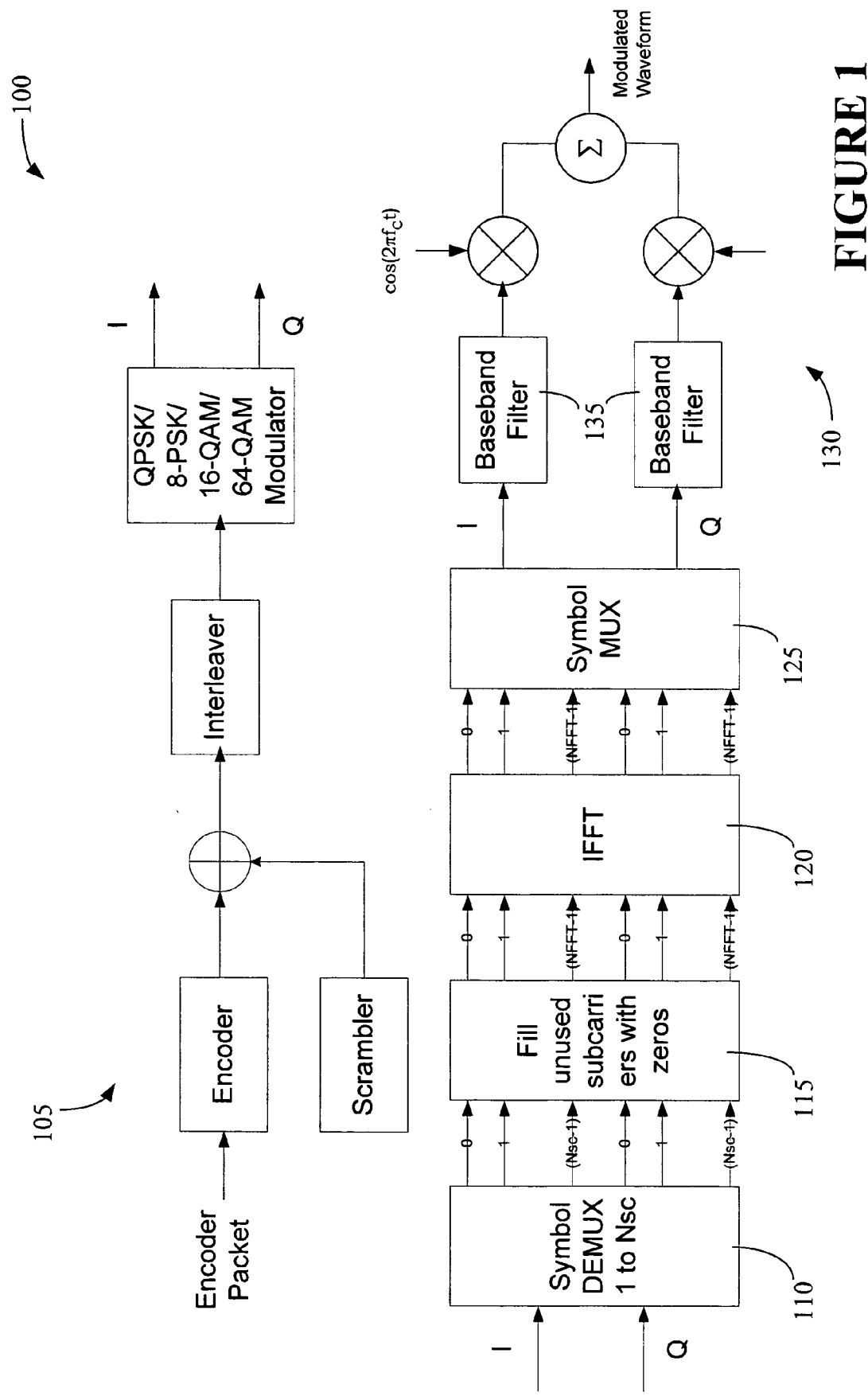

FIGURE 1

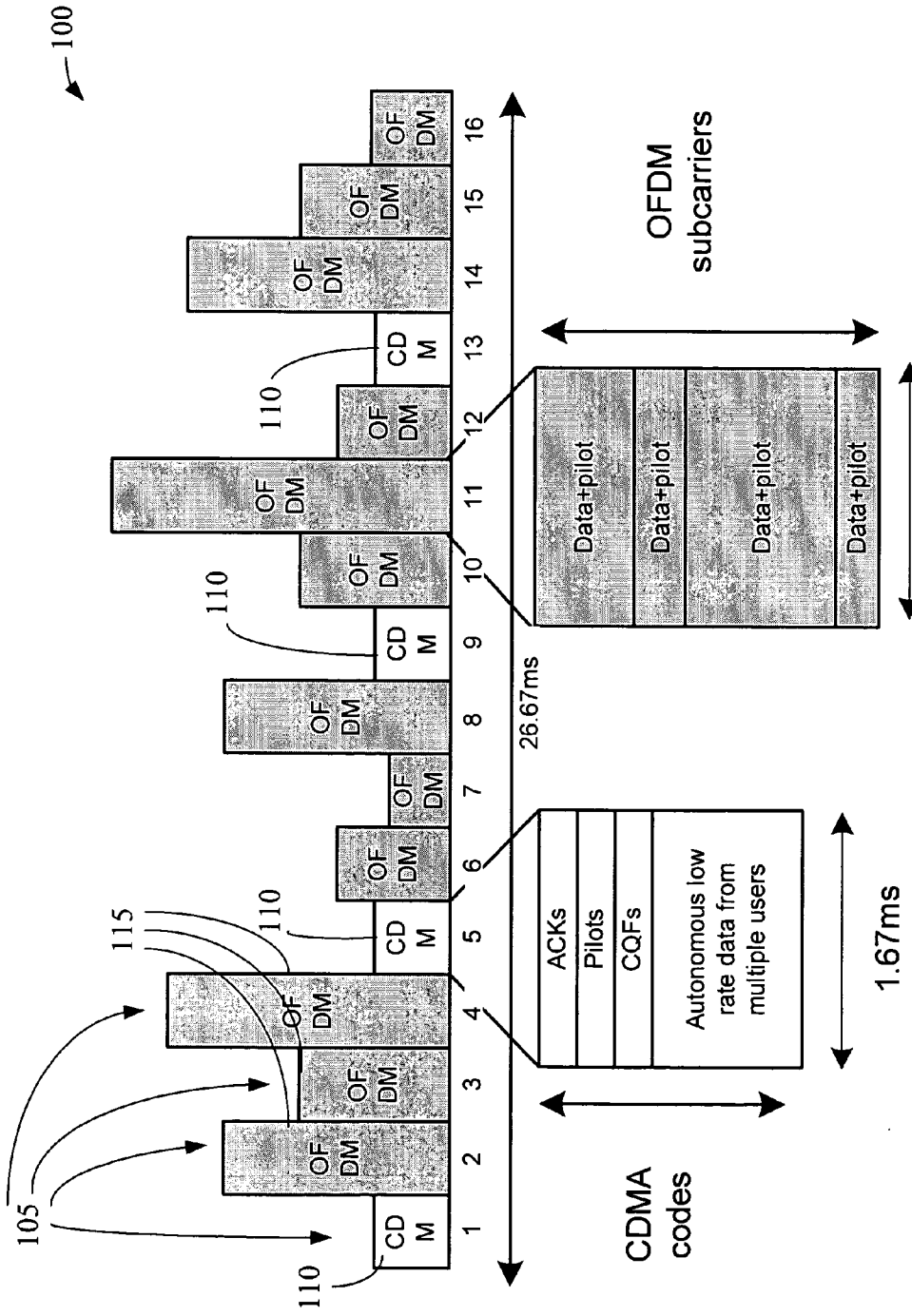
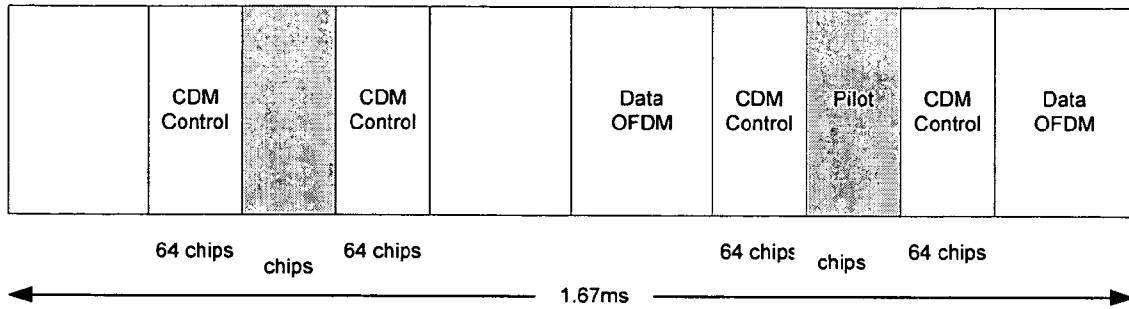

FIGURE 2

100

# FIGURE 3



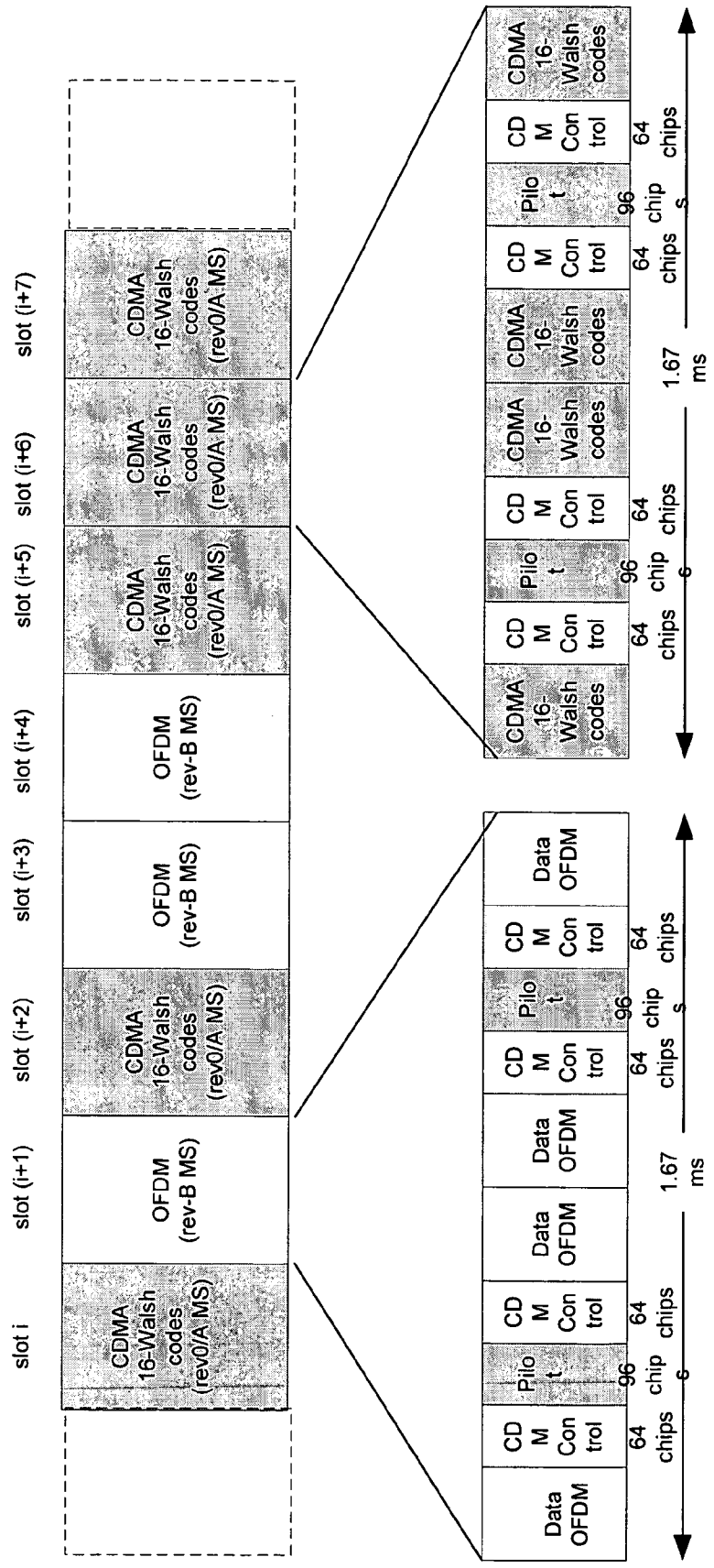
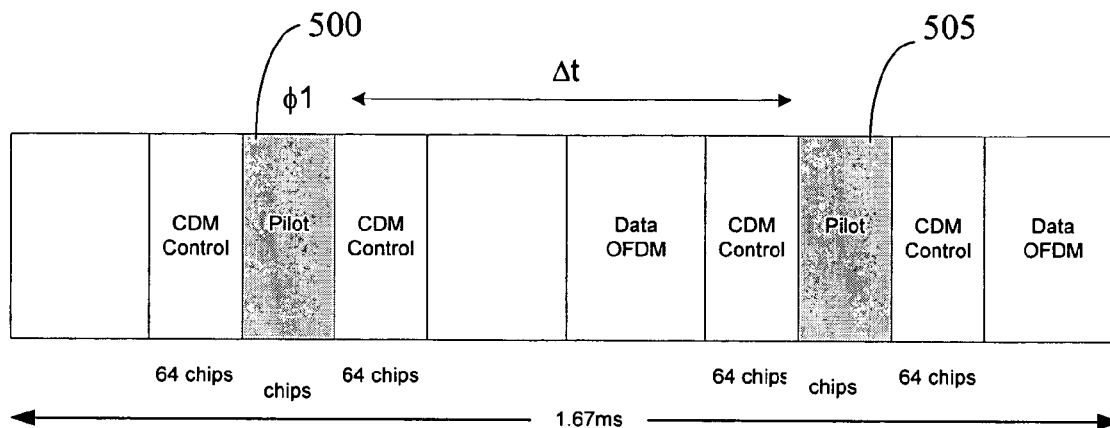
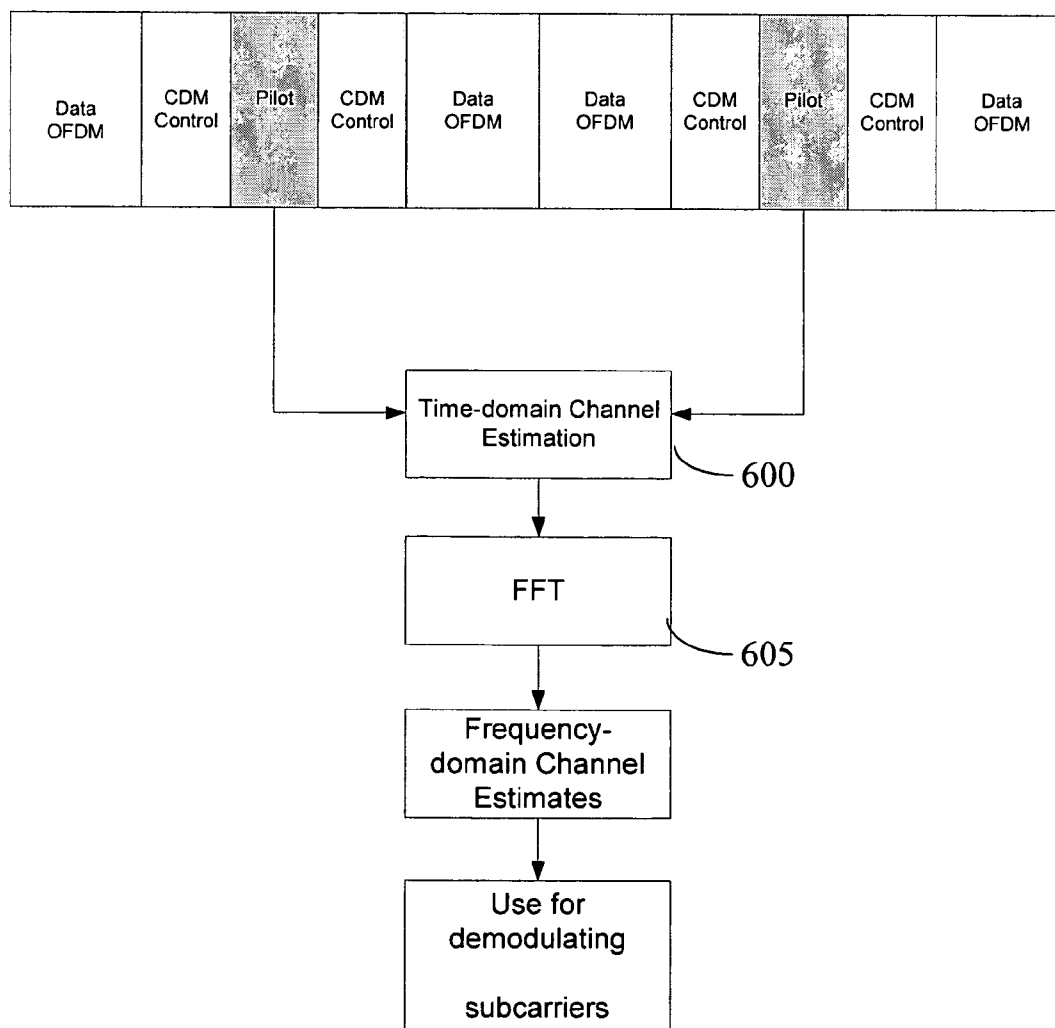

FIGURE 4

**FIGURE 5**



**FIGURE 6**



**FIGURE 7**

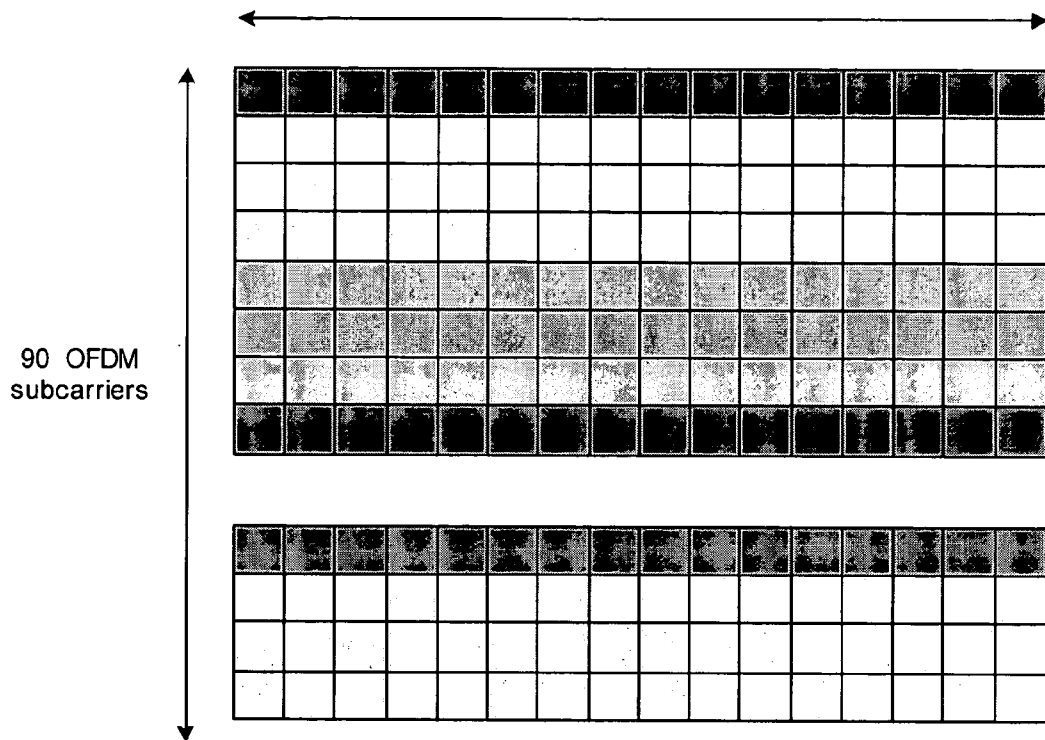

**FIGURE 8**

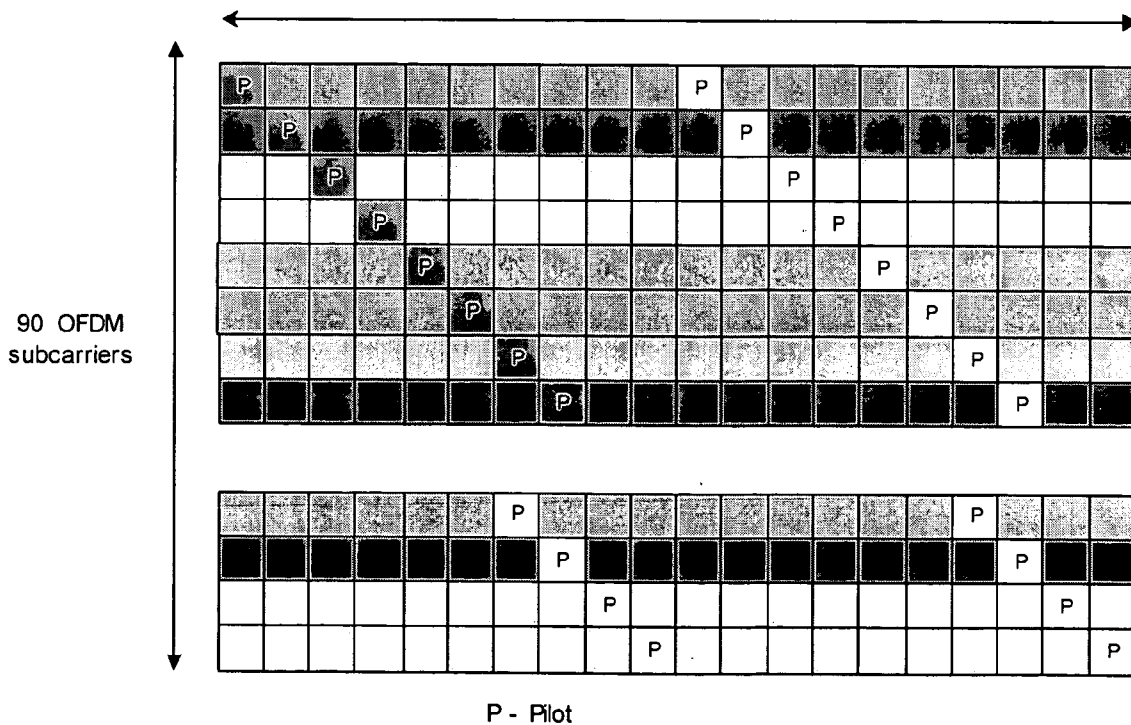

## HYBRID WIRELESS COMMUNICATIONS SYSTEM

### BACKGROUND OF THE INVENTION

**[0001]** 1. Field of the Invention

**[0002]** This invention relates generally to telecommunications, and more particularly, to wireless communications.

**[0003]** 2. Description of the Related Art

**[0004]** Within wireless communications, a variety of transmission techniques are employed. Two relatively common techniques are Code Division Multiple Access (CDMA) and Orthogonal Frequency Division Multiplexing (OFDM). CDMA is a modulation and multiple access technique where multiple users employing different orthogonal Walsh codes can be multiplexed onto a common frequency carrier. CDMA has been used in various wireless communications systems due to its useful properties of interference averaging and multipath diversity. Those skilled in the art will appreciate that spreading the signals in a CDMA system provides sufficient processing gain to allow decoding transmissions received at very low carrier-to-interference ratio (C/I). Therefore, a CDMA transmission can withstand high levels of interference, allowing deployments with universal frequency reuse (same frequency used in all the sectors in the system). Examples of wireless communications systems that employ CDMA are second generation IS-95 systems and third generation cellular systems, such as UMTS (Universal Mobile Telecommunications System) and cdma2000. CDMA is also used in the IEEE 802.11b standard for wireless LANs (Local Area Networks).

**[0005]** In a CDMA downlink (base station to mobile station), the transmissions on different Walsh codes are orthogonal when they are received at the mobile station. This is due to the fact that the signal is transmitted from a fixed location (base station) on the downlink and all the Walsh codes are received synchronized. Therefore, in the absence of multipath signals, transmissions on different codes do not interfere with each other. However, in the presence of multipath propagation (typical of cellular environments), the Walsh codes are no longer orthogonal, and thus, interfere with each other, producing Inter-Symbol Interference (ISI) and Multiple Access Interference (MAI). ISI and MAI limit the maximum achievable Signal-to-Noise Ratio (SNR), thereby limiting the maximum data rate that may be supported.

**[0006]** The problem is also present on a CDMA uplink (mobile station to base station) because the received Walsh codes from multiple users are not orthogonal even in the absence of any multipath signals. In the uplink, the propagation times from mobiles at different locations to the base station are often different. The received codes are not synchronized when they arrive at the base station, and therefore orthogonality cannot be guaranteed for signals coming from different mobiles. Transmissions from multiple users interfere with each other, generating Multiple Access Interference (MAI) and therefore contributing to the noise rise seen by each of the users. In general, the noise rise at the base station is kept below a certain threshold called the rise-over-thermal (RoT) threshold in order to guarantee desirable system capacity and coverage. The circuitry of the base station generates a certain amount of temperature

dependent noise called thermal noise. The RoT threshold limits the amount of power above the thermal noise at which mobile transmissions can be received. The threshold, along with interference from other users, limits the achievable data rates and capacity for transmissions on the CDMA uplink.

**[0007]** A stylized representation of a conventional OFDM transmitter chain **100** is shown in **FIG. 1**. Generally, a set of information bits called an encoder packet is coded, interleaved and modulated into Q symbols and I symbols by hardware/software/firmware **105**. A group of the I and Q symbols are serial-to-parallel converted by a de-multiplexer **110** and mapped to available subcarriers. Unused subcarriers are filled with zeros, and thus, carry no symbols, as stylistically represented at **115**. At **120** an IFFT (Inverse Fast Fourier Transform) operation is performed on the subcarrier symbols and the resulting symbols are parallel-to-serial converted by a multiplexer **125** to form a time-domain signal that is quadrature modulated and converted to an RF frequency for transmission by hardware/software/firmware **130**. In some embodiments of the OFDM transmitter chain **100**, a baseband filter **135** may be employed prior to converting to the RF frequency.

**[0008]** OFDM does not suffer some of the problems associated with CDMA. For example, ISI is substantially reduced by using longer symbol durations in OFDM. Moreover, the transmissions occur on orthogonal subcarriers without generating any Multiple Access Interference (MAI). In an OFDM system, a high data rate stream is converted from parallel to serial, resulting in a lower rate on each of the parallel streams. A lower rate on each of the streams allows using longer symbol duration. The multiple parallel data streams are mapped to orthogonal subcarriers in OFDM. The OFDM modulation efficiently uses the radio spectrum by placing modulated subcarriers as close as possible without causing Inter-Carrier Interference (ICI). Owing, at least in part, to its superior performance, OFDM modulation has been adopted in various standards, most notably digital audio broadcast (DAB), digital video broadcast (DVB), asymmetric digital subscriber line (ADSL), IEEE LAN (802.11a and 802.11g) and IEEE MAN 802.16a. OFDM modulation is also being considered for various next generation wireless standards.

**[0009]** While OFDM provides some benefits over CDMA, it also lacks some of the benefits of CDMA, such as interference averaging and absence of spreading (processing gain). Thus, OFDM may be limited to deployments with a frequency reuse factor of greater than 1, resulting in inefficient use of the scarce radio spectrum.

**[0010]** The present invention is directed to overcoming, or at least reducing, the effects of, one or more of the problems set forth above.

### SUMMARY OF THE INVENTION

**[0011]** In one embodiment of the present invention, a method for controlling transmissions between a mobile station and a base station is provided. The method comprises forming a frame having a plurality of slots therein. CDMA modulation is used in a first portion of the plurality of slots, and OFDM modulation is used in a second portion of the plurality of slots.

### BRIEF DESCRIPTION OF THE DRAWINGS

**[0012]** The invention may be understood by reference to the following description taken in conjunction with the

accompanying drawings, in which like reference numerals identify like elements, and in which:

[0013] **FIG. 1** illustrates a stylized representation of an OFDM transmitter chain;

[0014] **FIG. 2** illustrates a stylized representation of a signaling format that may be employed in an uplink channel in a hybrid CDMA/OFDM wireless system;

[0015] **FIG. 3** illustrates a stylized representation of a signaling format that may be employed in a downlink channel in hybrid CDMA/OFDM wireless system;

[0016] **FIG. 4** illustrates a stylized representation of a downlink slot structure for both CDMA and OFDM type slots;

[0017] **FIG. 5** illustrates a stylized representation of a method for using pilot signals in the signaling format of the downlink channel of **FIG. 3** for detecting frequency error;

[0018] **FIG. 6** illustrates a stylized representation of a method for using TDM pilots in the signaling format of the downlink channel of **FIG. 3** for channel estimation for demodulation in the frequency domain;

[0019] **FIG. 7** illustrates exemplary downlink OFDM slot structures; and

[0020] **FIG. 8** illustrates exemplary uplink OFDM slot structures.

[0021] While the invention is susceptible to various modifications and alternative forms, specific embodiments thereof have been shown by way of example in the drawings and are herein described in detail. It should be understood, however, that the description herein of specific embodiments is not intended to limit the invention to the particular forms disclosed, but on the contrary, the intention is to cover all modifications, equivalents, and alternatives falling within the spirit and scope of the invention as defined by the appended claims.

#### DETAILED DESCRIPTION OF SPECIFIC EMBODIMENTS

[0022] Illustrative embodiments of the invention are described below. In the interest of clarity, not all features of an actual implementation are described in this specification. It will of course be appreciated that in the development of any such actual embodiment, numerous implementation-specific decisions must be made to achieve the developers' specific goals, such as compliance with system-related and business-related constraints, which will vary from one implementation to another. Moreover, it will be appreciated that such a development effort might be complex and time-consuming, but would nevertheless be a routine undertaking for those of ordinary skill in the art having the benefit of this disclosure.

[0023] Generally, a hybrid wireless communications system that incorporates aspects of both CDMA and OFDM is disclosed herein. This hybrid system advantageously employs desirable properties of both CDMA and OFDM modulation. In the present invention, CDMA is used for physical layer signaling and control (e.g. random access, resource requests, resource grants, synchronization and power control commands) while OFDM with Hybrid ARQ is used for user information transmission. One embodiment

of the instant invention is described herein in the context of 1xEV-DO (a.k.a. HRPD) system parameters. However, those skilled in the art will appreciate that the principles of the present invention can also be applied to other wireless communications systems.

[0024] Turning now to the drawings, and referring specifically to **FIG. 2**, a stylized representation of a signaling format that may be employed over an uplink channel between mobile stations and a base station in a hybrid CDMA/OFDM wireless system is illustrated. The format comprises a frame **100** divided into a plurality of slots **105**, where a first portion of the slots **110** are used for CDMA transmissions and a second portion of the slots **115** are used for OFDM transmissions.

[0025] The physical layer signaling in 1xEV-DO, among others, consists of pilot, channel quality feedback and ACK/NACK feedback for the HARQ operation, as shown for one of the power control slots **110** in **FIG. 1**. **FIG. 1** shows an uplink channel having alternating CDMA power control (PC) slots **110** and OFDM slots **115**. That is, the CDMA PC slots **110** are distributed throughout the frame to allow the mobile station to periodically update the power with which it transmits. Thus, a sufficient number of PC slots **110** should be provided to allow updating to occur on a sufficiently short and regular basis.

[0026] The transmissions in the power control slots **110** include physical layer control signaling and are power controlled, as in a conventional CDMA system. The Rise-over-Thermal (RoT) is kept below an RoT threshold in these PC slots **110** in order to increase the likelihood that an acceptable capacity/coverage to the critical physical layer control signaling. The OFDM slots **115** are used for user data transmissions in an OFDMA fashion, i.e. multiple users can potentially transmit on orthogonal subcarriers within the slots **115**.

[0027] A dedicated pilot for each of the active users is carried in the CDMA slots **110**. The pilot transmit power is updated with every CDMA slot **110** based on a Transmit Power Control (TPC) bit received from the base station on the Downlink. This allows the received pilot power to be substantially maintained at a desired level without creating excessive interference in the system. The OFDM transmissions can also be power controlled by allocating power in OFDM slots using the pilot transmit power as a reference. For example, a specified Traffic-to-Pilot Ratio (TPR) can be indicated to the mobile station via a scheduling grant message sent by the base station. The mobile station can then use this TPR to determine the power needed for transmission in the OFDM slots when it is scheduled for transmissions on the uplink.

[0028] In the downlink, CDMA and OFDM symbols are time-multiplexed within a 1.67 ms slot on the same 1.25 MHz carrier, as shown in **FIG. 3**. The downlink slot structure is the same as in current HRPD revision 0 and revision A standards. The only substantial difference is that that CDMA chips in the "Data" fields have been replaced by OFDM symbols. This allows for new and legacy mobile stations to share the downlink resource on a slot-by-slot basis, as shown in **FIG. 4**. The pilot and MAC fields are unchanged and are present in all the slots (i.e., Idle slots, CDMA slots and OFDM slots). This allows for the legacy mobiles to operate seamlessly.

[0029] Downlink TDM (Time Division Multiplex) pilots may be used to estimate (and compensate) frequency error, as shown in FIG. 5. The frequency error can be determined based on the phase difference and time difference between the two TDM pilots within slots 500, 505 using the following equation:

$$\delta w = \frac{\phi_2 - \phi_1}{\Delta t}$$

[0030] Note that the time difference between the two TDM pilots is fixed and known to the receiver. The phase can be estimated based on the received pilot symbols. Similarly, on the uplink, CDM pilots in the power-controlled CDM slots (and embedded time-freq pilots in OFDM data slots) can be used to estimate the frequency error.

[0031] The information carried in the CDM slots on the uplink and pilot and MAC fields on the downlink is scrambled by PN codes used in the IS-95 wireless communication system. These PN codes can also be used to derive the synchronization and timing information for the OFDM transmissions. For example, timing derived from PN sequences can also be used for OFDM receiver's FFT (Fast Fourier Transform) window alignment.

[0032] The TDM pilots on the downlink can also be used for channel estimation for demodulation in the frequency domain (OFDM) as shown in FIG. 6. With the TDM pilots, the channel can be estimated in the time-domain (at 600) and then transformed to frequency domain by taking an FFT (fast fourier transform) (at 605) of the time-domain estimates. Similarly, dedicated CDMA pilots on the uplink can be used to provide uplink channel estimates in the frequency domain. Additional pilots in the frequency domain can also be provided in the OFDM slots both on the downlink and uplink in order to increase the reliability of the channel estimation. The final channel estimates can then be obtained based on both the time-domain and frequency domain pilots.

[0033] An exemplary set of system parameters for the hybrid CDMA/OFDM system is provided in Table 1 for illustration.

TABLE 1

Parameter	Symbol	Value
CDMA Chip rate	BW	1.2288 Mchips/s
OFDM Sampling Frequency	Fs	1.72032 Ms/s
Sampling frequency to channel bandwidth ratio	Fs/BW	7/5
OFDM FFT size	NFFT	128
OFDM subcarrier spacing	Df	13.44 KHz
Useful symbol time	Tb = 1/Df	74.4 ms
OFDM Cyclic prefix (guard period)	Tg	
DL-6.98 ms, UL-8.93 ms	OFDM symbol time	Tb + Tg
	DL-81.38 ms,	OFDM Symbol rate
	UL-83.33 ms	
1/(Tb + Tg)	DL-12.288 KHz	UL-12.0 KHz

[0034] Exemplary downlink and uplink OFDM slot structures are shown in FIG. 7 and FIG. 8, respectively. Note that additional pilot symbols are shown in the uplink slot structure.

[0035] Exemplary uplink and downlink data rates, modulation and coding schemes are given in Table 2 and Table 3, respectively. The modulation and coding schemes are determined based on the assumption that all of the 90 subcarriers are used for transmission to a single user. Those skilled in the art will appreciate that the formats can be extended for the case where a subset of the 90 subcarriers is used for data transmission to a given user. Also, 192 pilot symbols and 1608 data symbols per slot are assumed for the uplink case.

TABLE 2

Data Rate [Kb/s]	Information Block Size [bits]	Modulation Order	Effective Coding Rate
76.8	128	2	0.040
153.6	256	2	0.080
307.2	512	2	0.159
460.8	768	2	0.239
614.4	1024	2	0.318
921.6	1536	2	0.478
1228.8	2048	3	0.425
1843.2	3072	3	0.637
2457.6	4096	4	0.637
3072	5120	4	0.796
3686.4	6144	6	0.637
4300.8	7168	6	0.743

[0036]

TABLE 3

DATA RATE [KB/S]	Information Block Size [bits]	Modulation Order	Effective Coding Rate
76.8	128	2	0.044
153.6	256	2	0.089
307.2	512	2	0.178
460.8	768	2	0.267
614.4	1024	2	0.356
921.6	1536	2	0.533
1228.8	2048	3	0.474
1843.2	3072	4	0.533
2457.6	4096	4	0.711
3072	5120	4	0.889
3686.4	6144	6	0.711
4300.8	7168	6	0.830

[0037] Those skilled in the art will appreciate that the various system layers, routines, or modules illustrated in the various embodiments herein may be executable control units. The control units may include a microprocessor, a microcontroller, a digital signal processor, a processor card (including one or more microprocessors or controllers), or other control or computing devices as well as executable instructions contained within one or more storage devices. The storage devices may include one or more machine-readable storage media for storing data and instructions. The storage media may include different forms of memory including semiconductor memory devices such as dynamic or static random access memories (DRAMs or SRAMs), erasable and programmable read-only memories (EPROMs), electrically erasable and programmable read-only memories (EEPROMs) and flash memories; magnetic disks such as fixed, floppy, removable disks; other magnetic media including tape; and optical media such as compact disks (CDs) or digital video disks (DVDs). Instructions that make up the various software layers, routines, or modules in

the various systems may be stored in respective storage devices. The instructions, when executed by a respective control unit, causes the corresponding system to perform programmed acts.

[0038] The particular embodiments disclosed above are illustrative only, as the invention may be modified and practiced in different but equivalent manners apparent to those skilled in the art having the benefit of the teachings herein. Furthermore, no limitations are intended to the details of construction or design herein shown, other than as described in the claims below. It is therefore evident that the particular embodiments disclosed above may be altered or modified and all such variations are considered within the scope and spirit of the invention. Accordingly, the protection sought herein is as set forth in the claims below.

We claim:

1. A method for controlling transmissions between a mobile station and a base station, the method comprising:

transmitting a frame of information using CDMA and OFDM.

2. A method, as set forth in claim 1, wherein transmitting a frame of information using CDMA and OFDM further comprises:

forming a frame having a plurality of slots therein;  
using CDMA in a first portion of the plurality of slots; and  
using OFDM in a second portion of the plurality of slots.

3. A method, as set forth in claim 1, wherein using CDMA in a first portion of the plurality of slots further comprises using CDMA for at least one of physical layer signaling and control.

4. A method, as set forth in claim 2, wherein using CDMA for at least one of physical layer signaling and control further comprises the physical layer signaling including at least one of pilot, channel quality feedback and ACK/NACK.

5. A method, as set forth in claim 1, wherein using CDMA in a first portion of the plurality of slots further comprises using CDMA power control slots.

6. A method, as set for in claim 5, wherein using CDMA power control slots further comprises distributing CDMA power slots throughout the frame.

7. A method, as set forth in claim 6, wherein distributing CDMA power slots throughout the frame further comprises distributing CDMA power slots substantially uniformly throughout the frame.

8. A method, as set forth in claim 2, wherein using OFDM in a second portion of the plurality of slots further comprises using OFDM for user data transmissions.

9. A method for controlling transmissions between a mobile station and a base station, the method comprising:

receiving a frame of information using CDMA and OFDM.

10. A method, as set forth in claim 9, wherein receiving a frame of information using CDMA and OFDM further comprises:

receiving a frame having a plurality of slots therein, wherein CDMA is used in a first portion of the plurality of slots, and OFDM is used in a second portion of the plurality of slots.

11. A method, as set forth in claim 9, wherein CDMA is used in a first portion of the plurality of slots to effect at least one of physical layer signaling and control.

12. A method, as set forth in claim 10, wherein using CDMA to effect at least one of physical layer signaling and control further comprises the physical layer signaling including at least one of pilot, channel quality feedback and ACK/NACK.

13. A method, as set forth in claim 9, wherein CDMA being used in a first portion of the plurality of slots further comprises CDMA power control slots being used in a first portion of the plurality of slots.

14. A method, as set for in claim 13, wherein CDMA power control slots being used further comprises CDMA power slots being distributed throughout the frame.

15. A method, as set forth in claim 14, wherein CDMA power slots being distributed throughout the frame further comprises CDMA power slots being substantially uniformly distributed throughout the frame.

16. A method, as set forth in claim 10, wherein OFDM being used in a second portion of the plurality of slots further comprises OFDM being used for data transmissions.

\* \* \* \* \*