



US005592199A

United States Patent [19]

[11] Patent Number: **5,592,199**

Kawaguchi et al.

[45] Date of Patent: **Jan. 7, 1997**

[54] **ASSEMBLY STRUCTURE OF A FLAT TYPE DEVICE INCLUDING A PANEL HAVING ELECTRODE TERMINALS DISPOSED ON A PERIPHERAL PORTION THEREOF AND METHOD FOR ASSEMBLING THE SAME**

2-259728 10/1990 Japan .
4-115228 4/1992 Japan .
4-313731 5/1992 Japan .
4-304427 10/1992 Japan .

OTHER PUBLICATIONS

[75] Inventors: **Hisao Kawaguchi; Shinichi Sugimoto,** both of Nara; **Yasunobu Tagusa,** Ikoma, all of Japan

Patent Abstracts of Japan, vol. 17, No. 138 (P-1505) 22 Mar. 1993.

Patent Abstracts of Japan, vol. 17, No. 118 (P-1500) Mar. 11, 1993.

[73] Assignee: **Sharp Kabushiki Kaisha,** Osaka, Japan

Patent Abstracts of Japan, vol. 16, No. 368 (P-1398) Aug. 7, 1992.

[21] Appl. No.: **186,455**

Patent Abstracts of Japan, vol. 14, No. 577 (P1146) Dec. 21, 1990.

[22] Filed: **Jan. 25, 1994**

“'93 The newest LC process technique”, (from Monthly Semiconductor World extra number; pp. 249-252).

[30] Foreign Application Priority Data

Jan. 27, 1993 [JP] Japan 5-011728
Feb. 8, 1993 [JP] Japan 5-020295
Aug. 6, 1993 [JP] Japan 5-196416

Primary Examiner—Kee M. Tung
Assistant Examiner—Matthew Luu

[51] **Int. Cl.⁶** **G09G 5/00**
[52] **U.S. Cl.** **345/206; 345/87; 29/846**
[58] **Field of Search** **345/87, 98, 206; 361/805; 29/854, 846**

[57] ABSTRACT

A panel having a plurality of electrode terminals disposed along a peripheral portion of one surface thereof is assembled at small size, less weight, and low cost. Flexible wiring boards on which a drive IC is mounted are connected to the electrode terminals, and circuit wiring is connected to the flexible wiring boards. On both sides of the peripheral portion of the panel, a first junction terminal and a second junction terminal are provided. By a first circuit wiring, the second junction terminal corresponding to one flexible wiring board is connected to the first junction terminal corresponding to another flexible wiring board adjacent to the flexible wiring board. An input terminal, output terminals, and a third junction terminal that lead to the drive IC are provided at places corresponding to the various terminals on one surface of the flexible wiring boards. By the second circuit wiring, the input terminal is connected to the third junction terminal. The corresponding terminals are connected to each other by overlapping the flexible wiring boards on the peripheral portion of the panel.

[56] References Cited

U.S. PATENT DOCUMENTS

4,766,426 8/1988 Hatada et al. .
5,025,555 6/1991 Mase 29/846
5,072,075 12/1991 Lee et al. 29/846
5,375,322 12/1994 Leeb 29/846

FOREIGN PATENT DOCUMENTS

0455233 11/1991 European Pat. Off. .
61-114226 5/1986 Japan .
62-237484 10/1987 Japan .
63-126292 5/1988 Japan .
63-205074 8/1988 Japan .
649284 1/1989 Japan .
2-27785 1/1990 Japan .
2-127621 5/1990 Japan .
2-248926 10/1990 Japan .

5 Claims, 41 Drawing Sheets

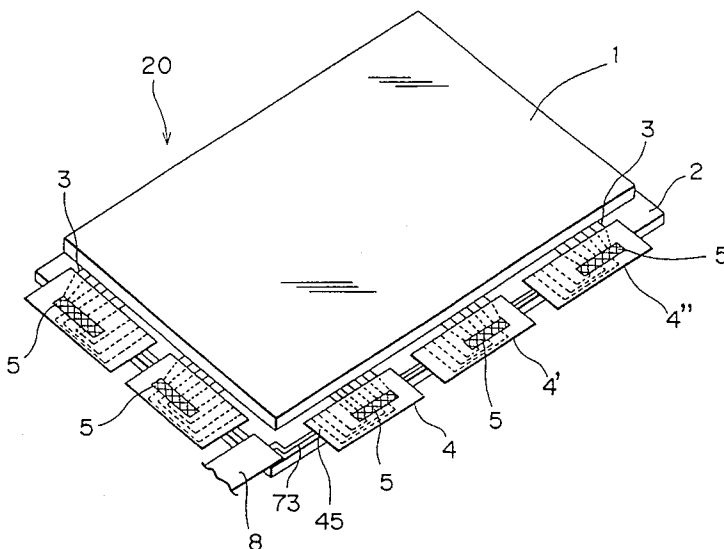

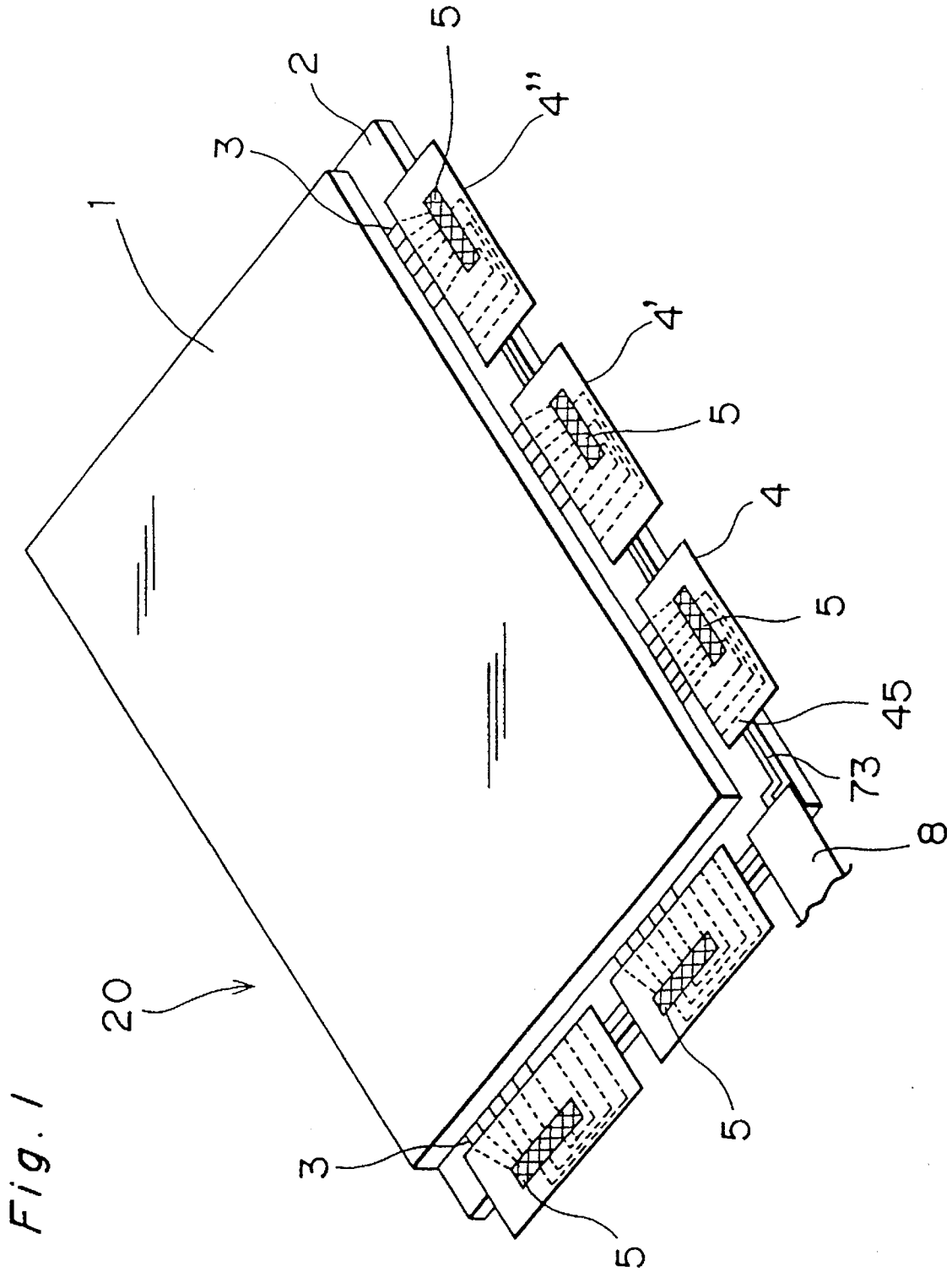

Fig. 1

Fig. 2

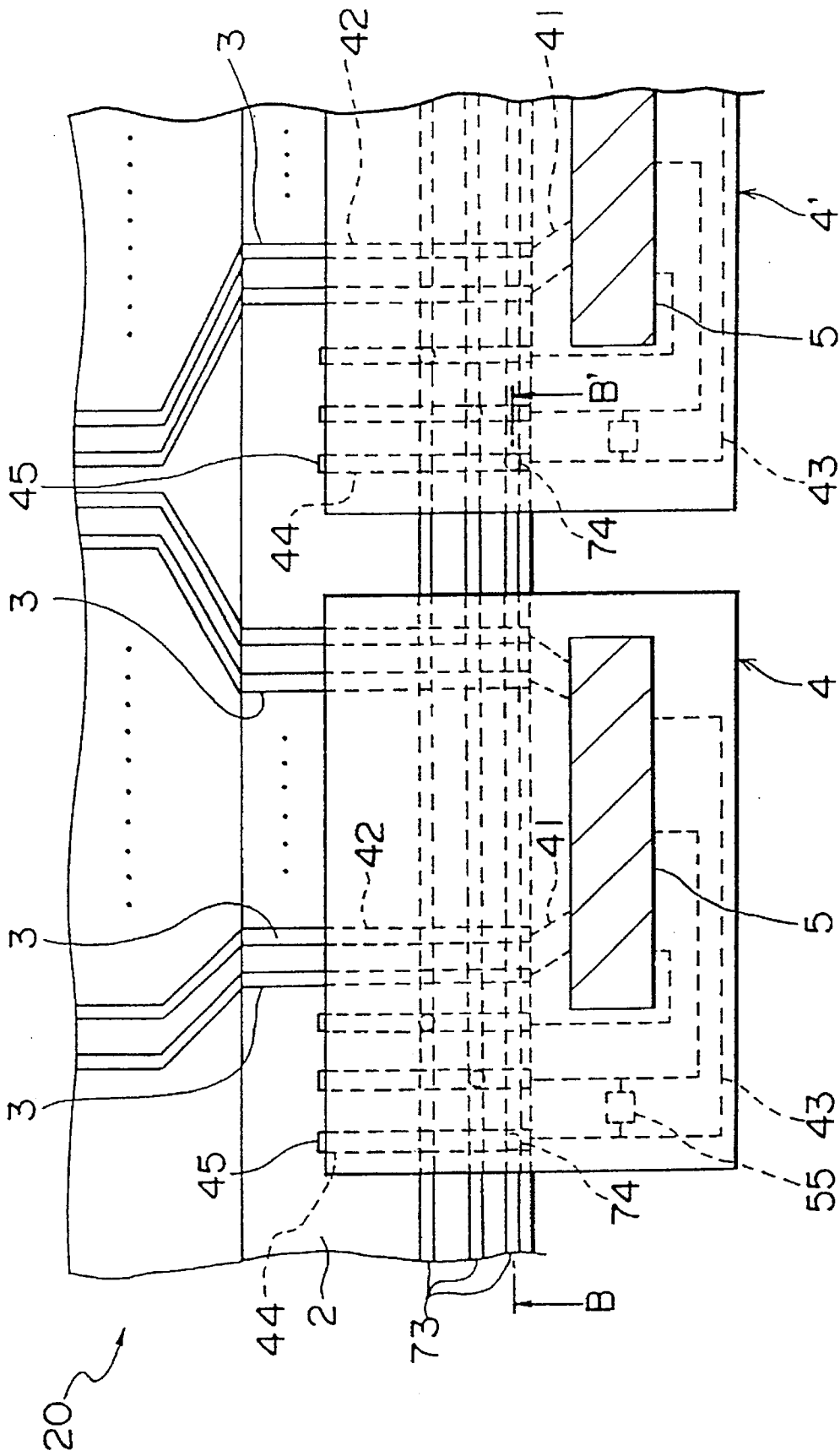

Fig. 3

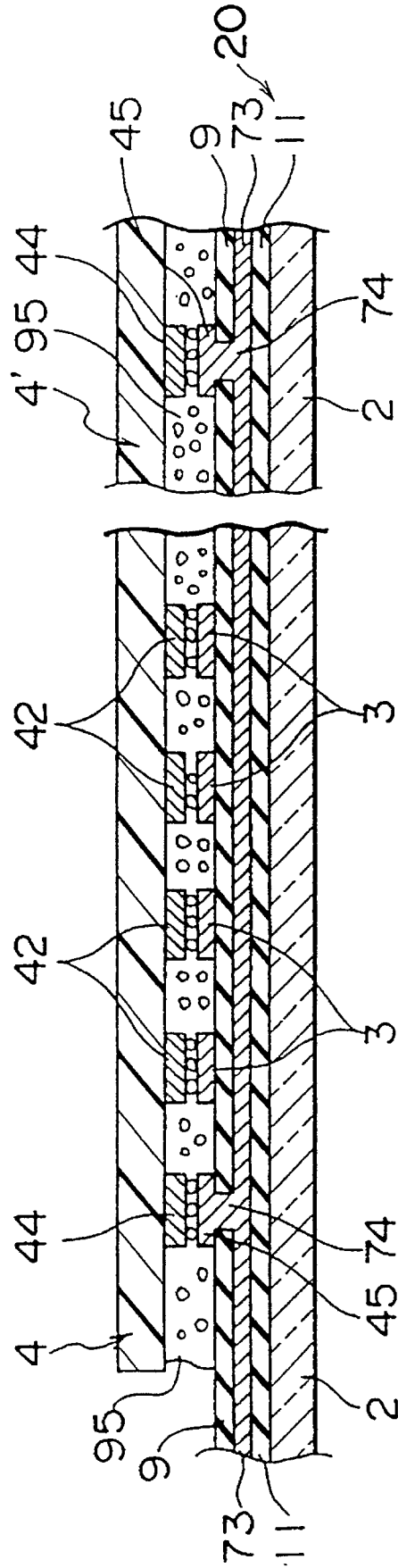

Fig. 4(a)

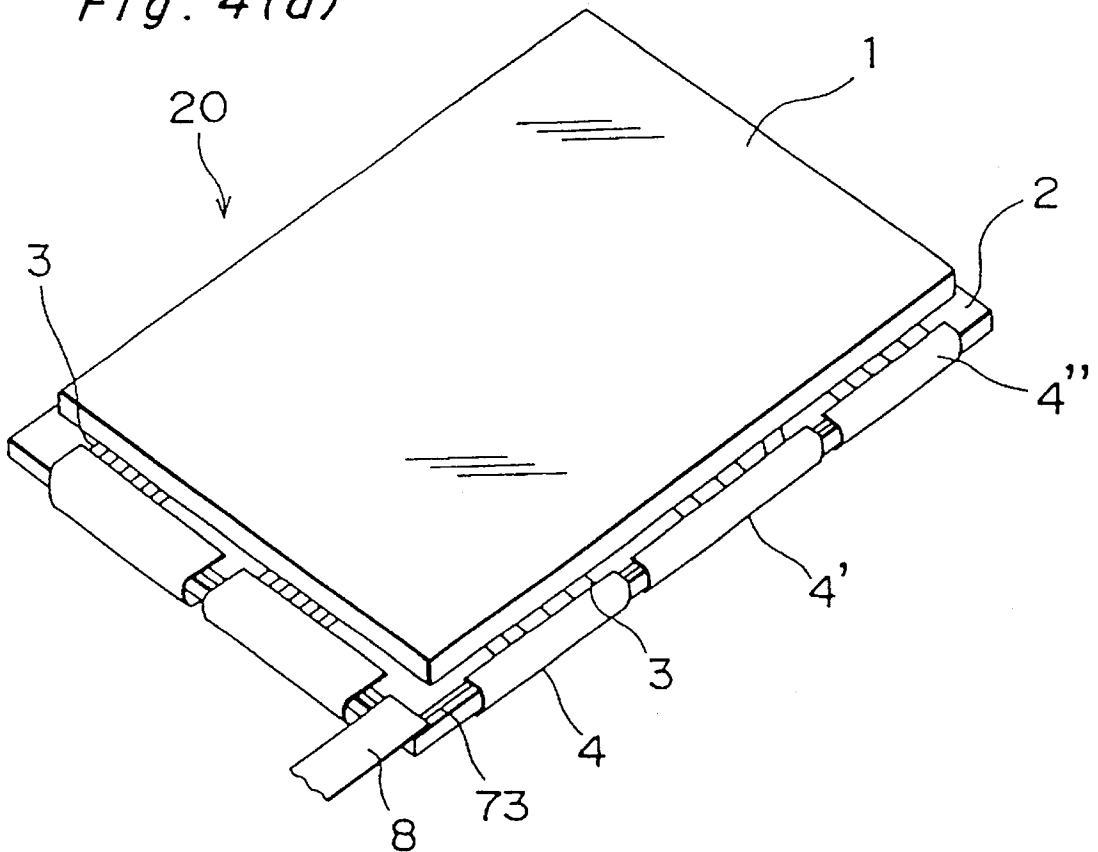

Fig. 4(b)

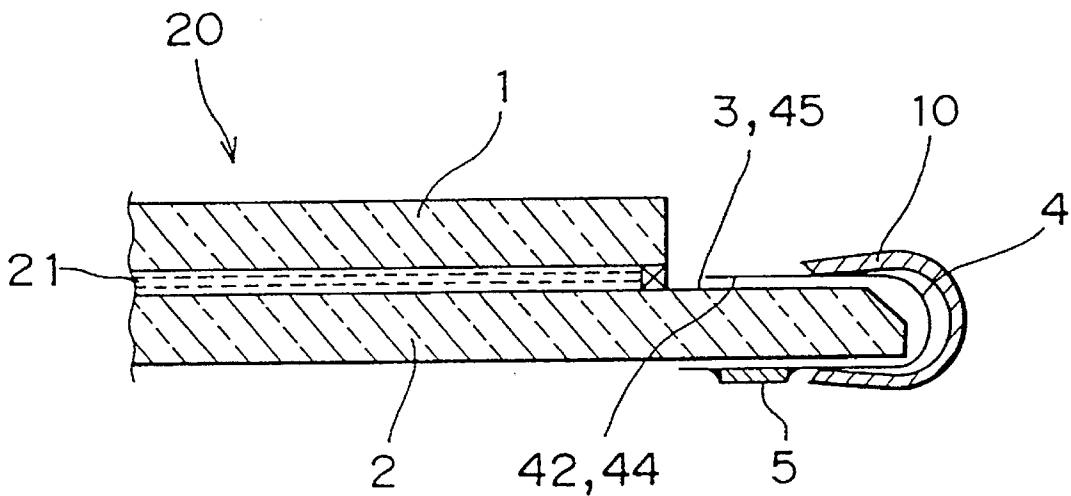

Fig. 5(a)

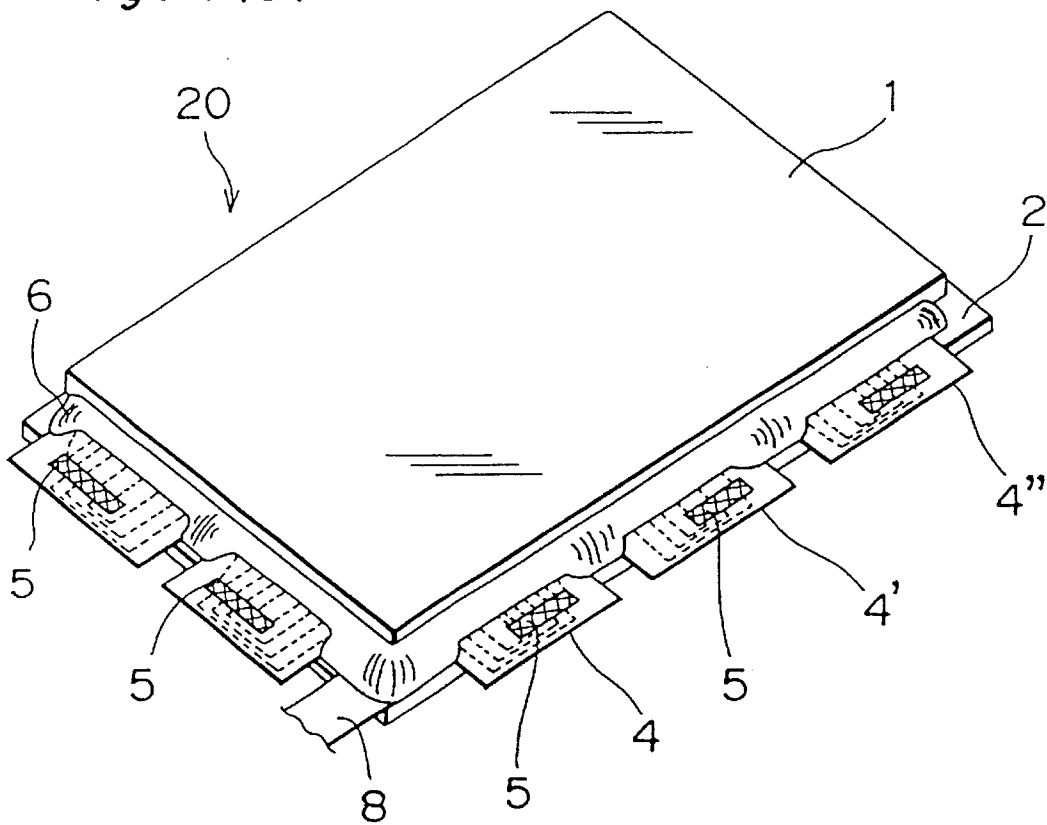
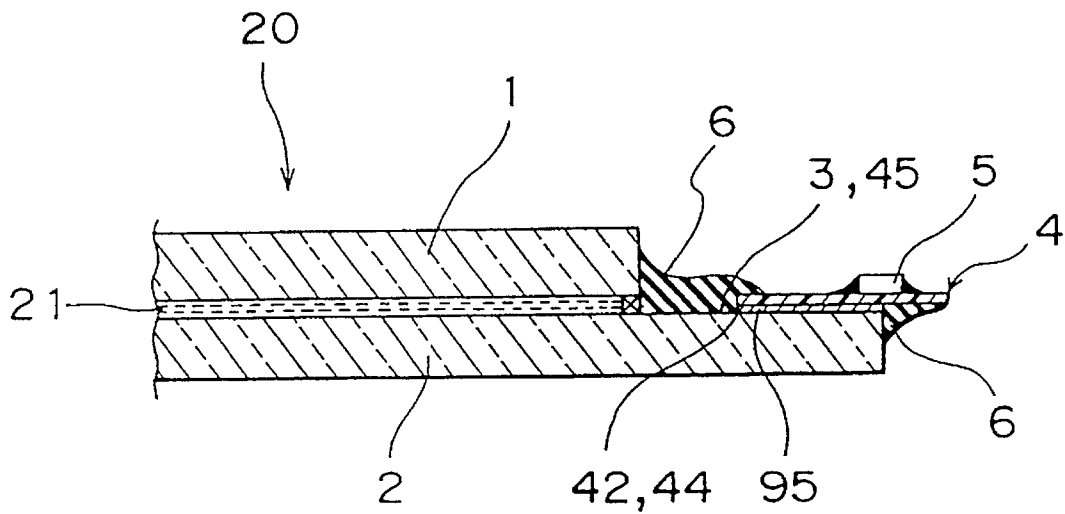
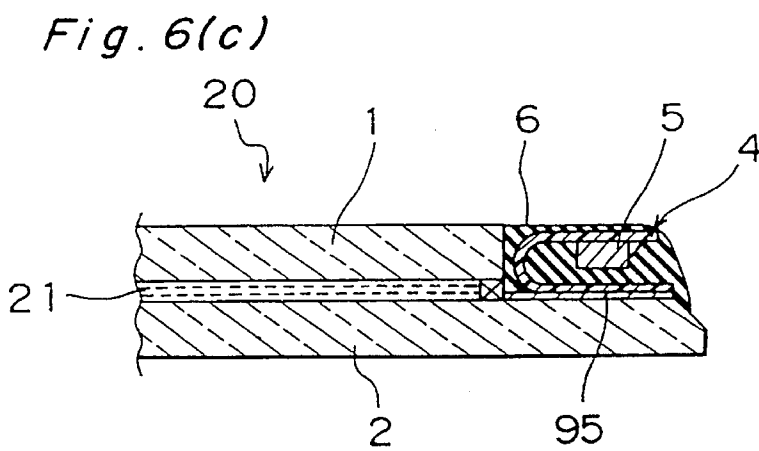
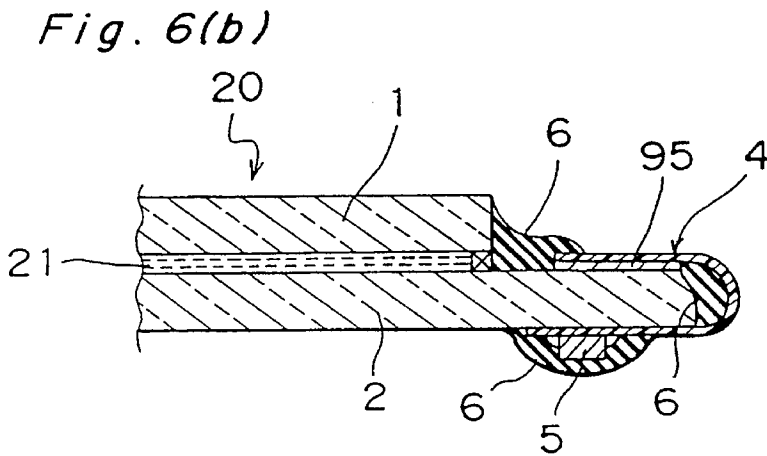
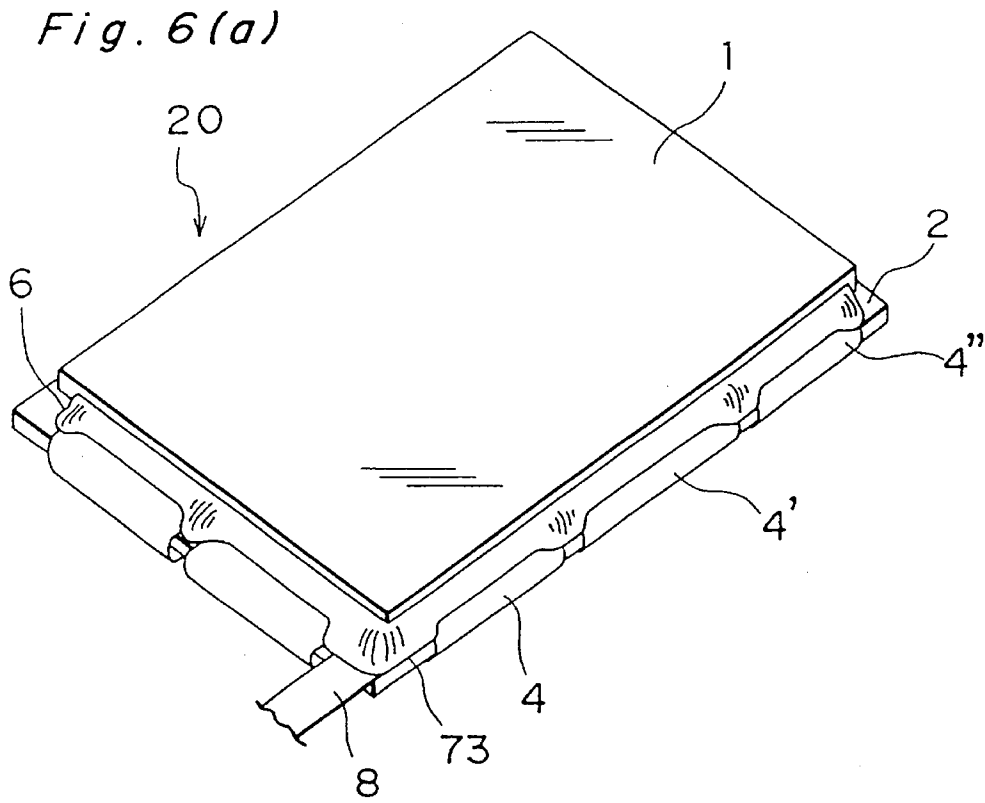

Fig. 5(b)





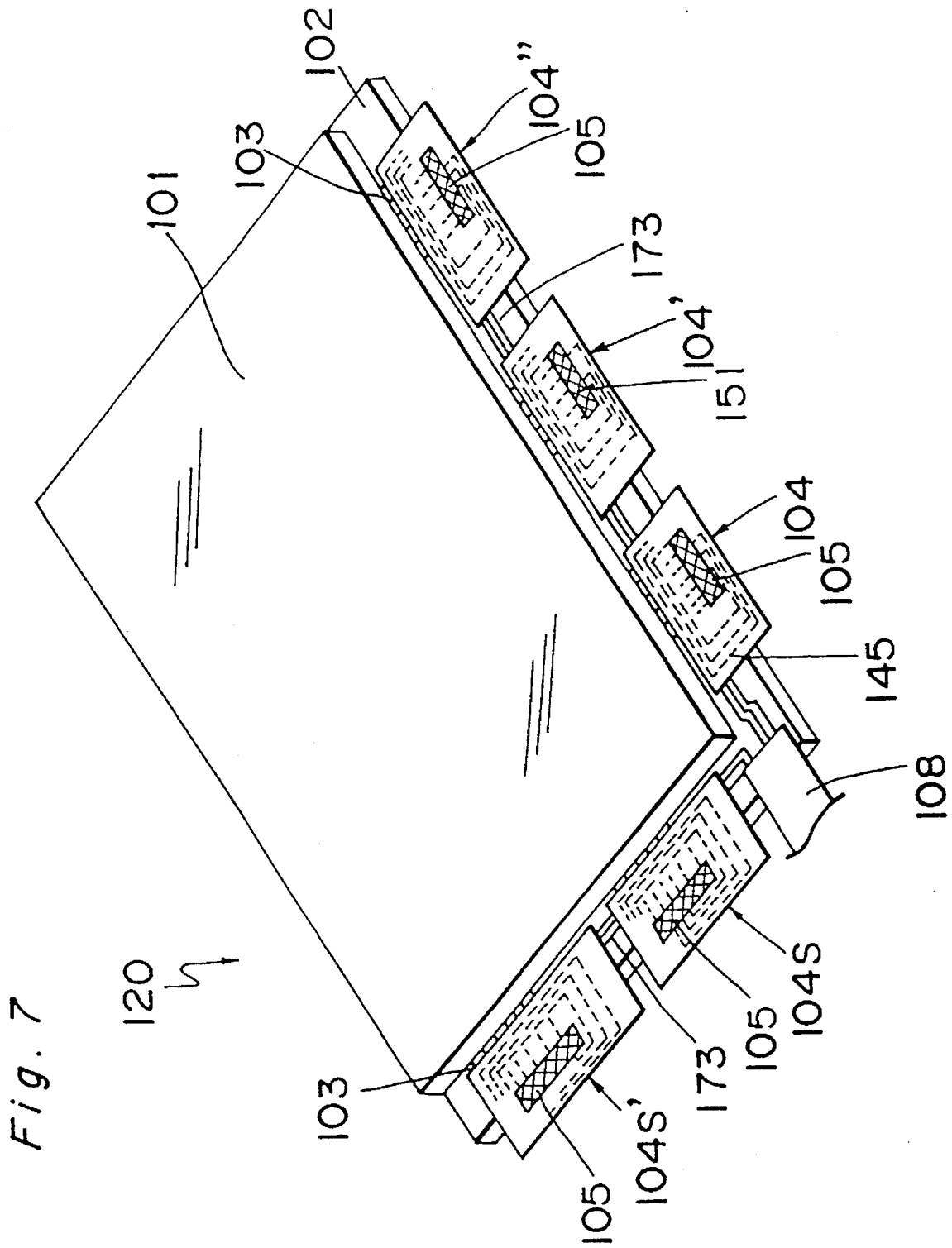

Fig. 7

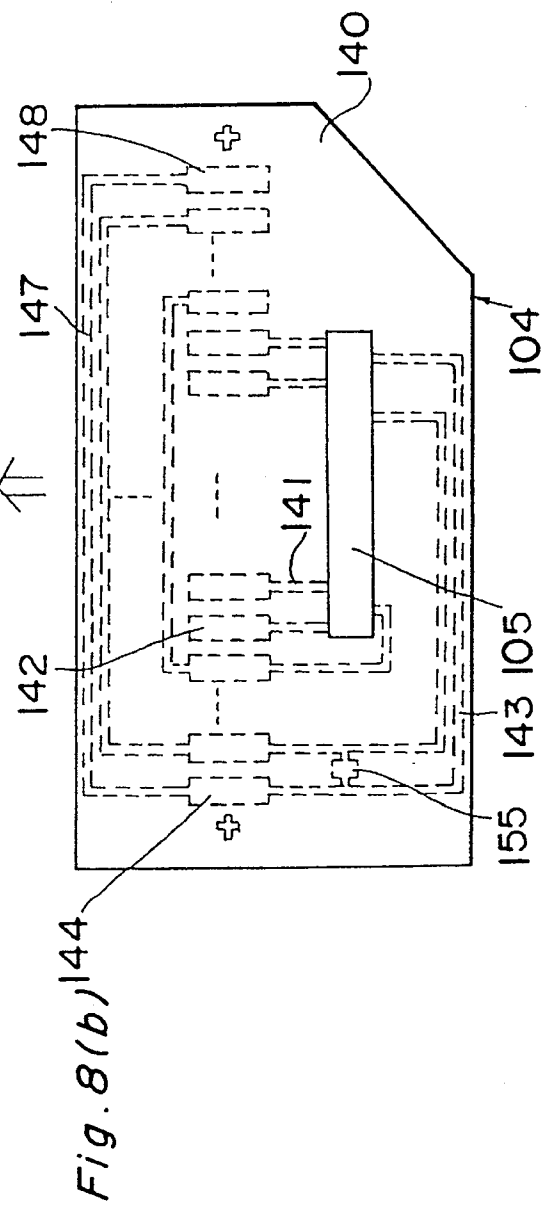
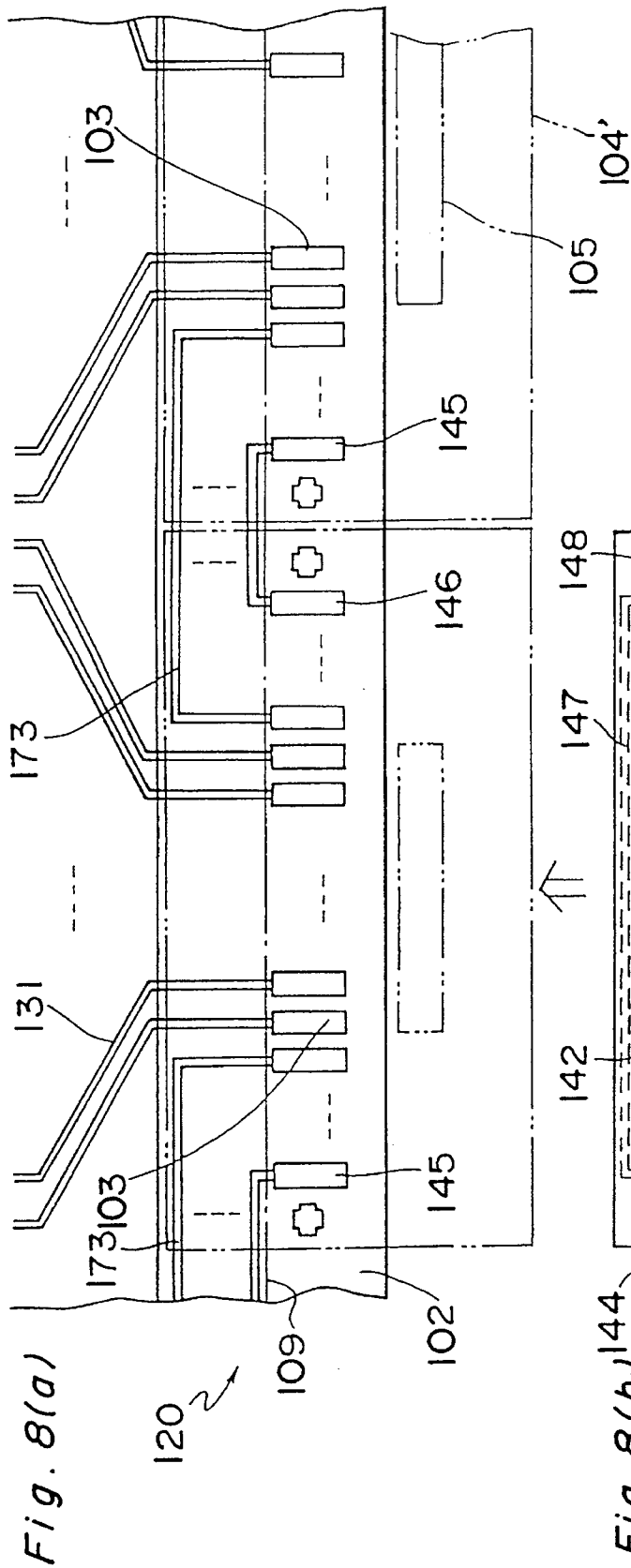

Fig. 9

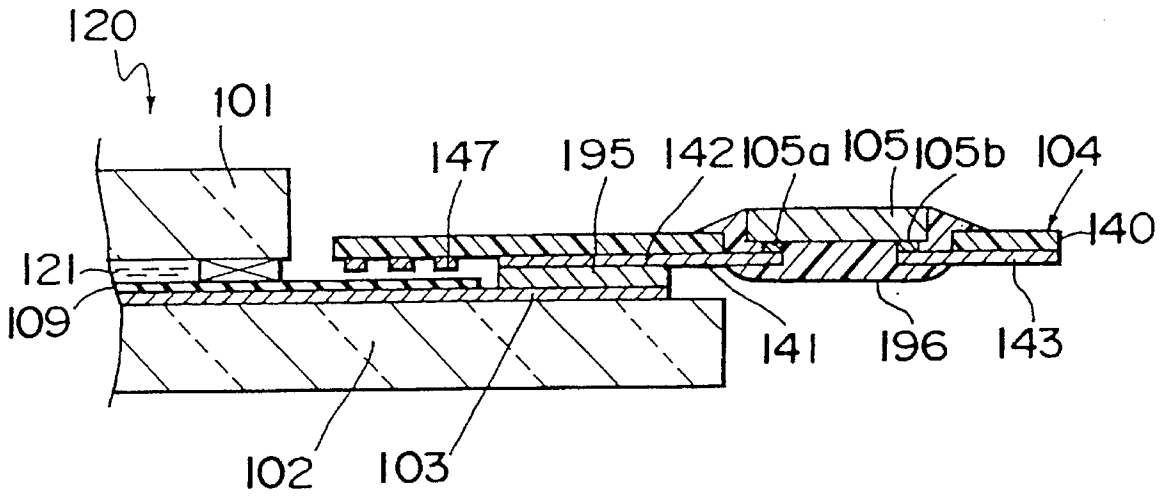

Fig. 10

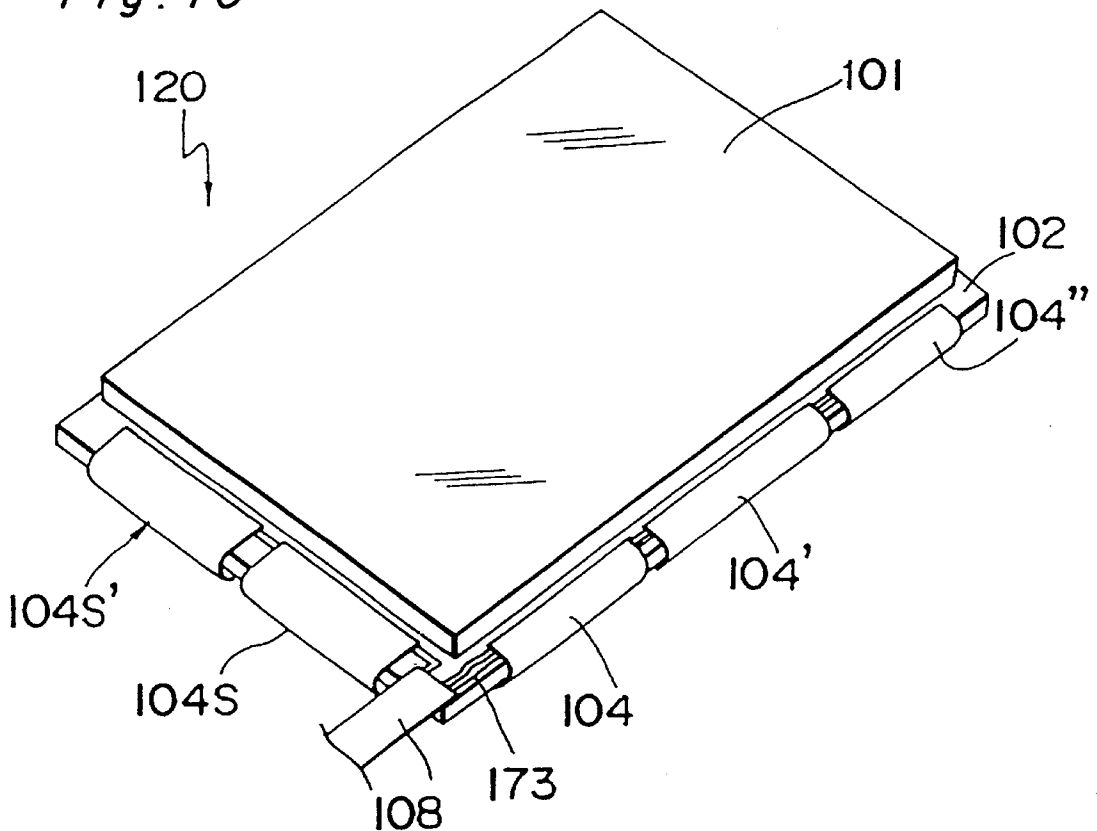

Fig. 11

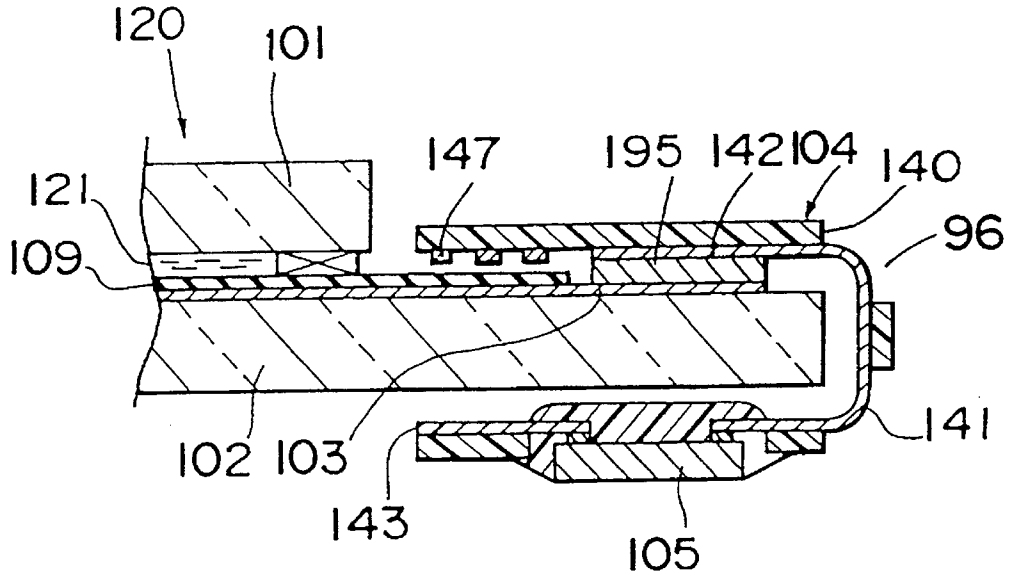

Fig. 12

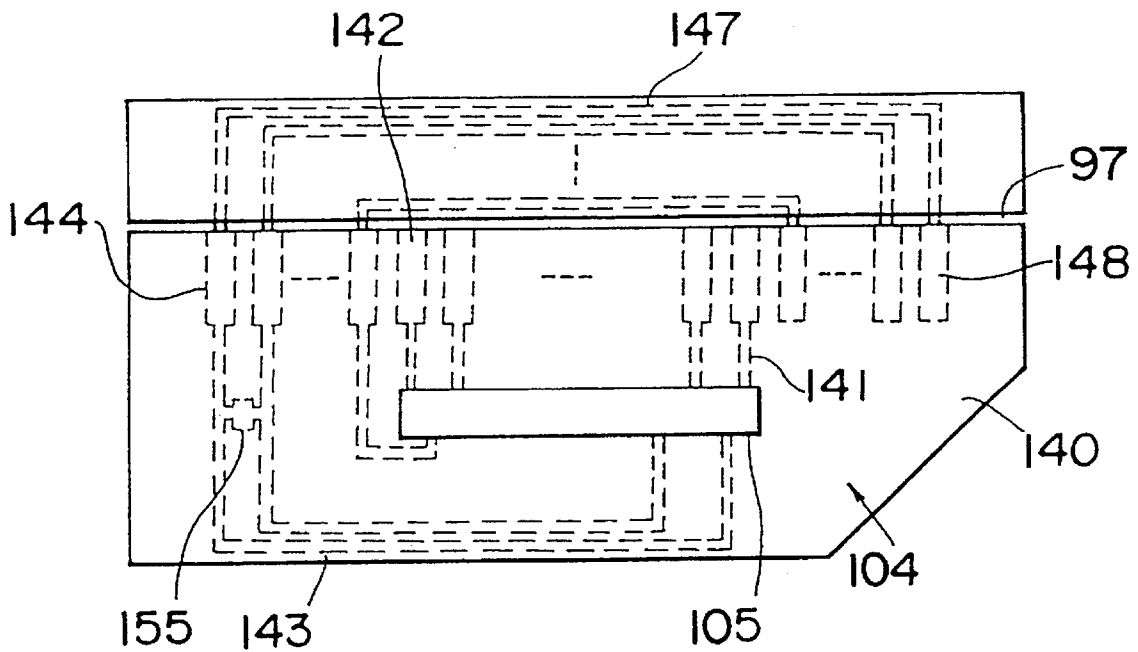

Fig. 13

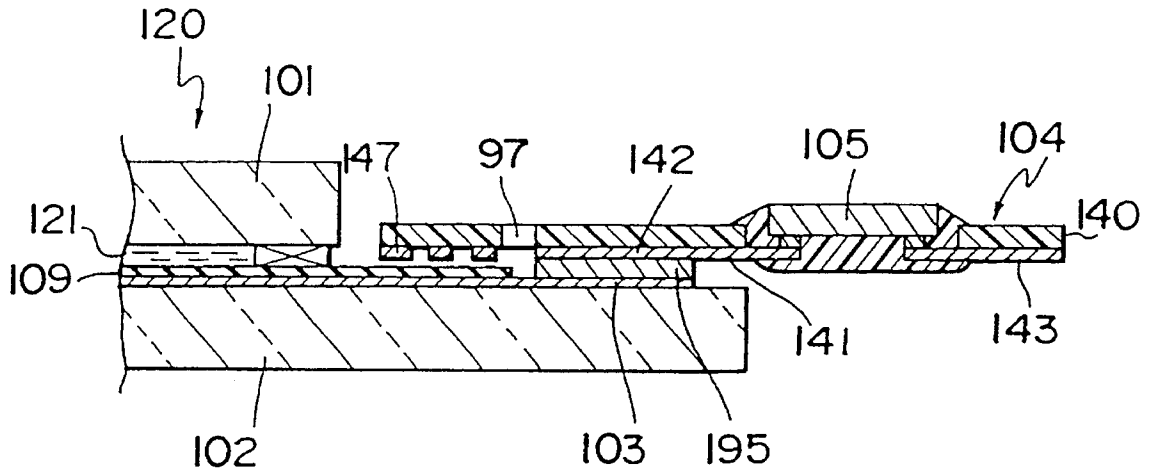

Fig. 14

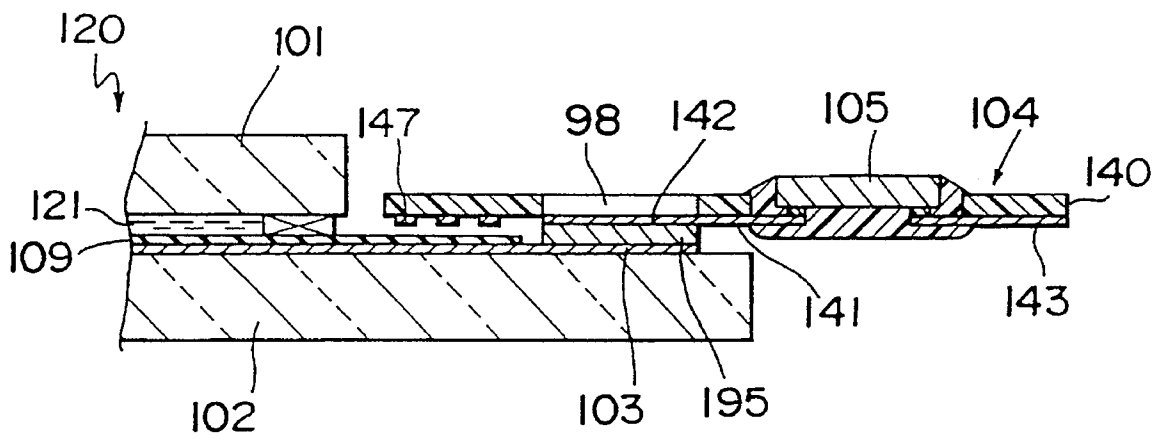

Fig. 15

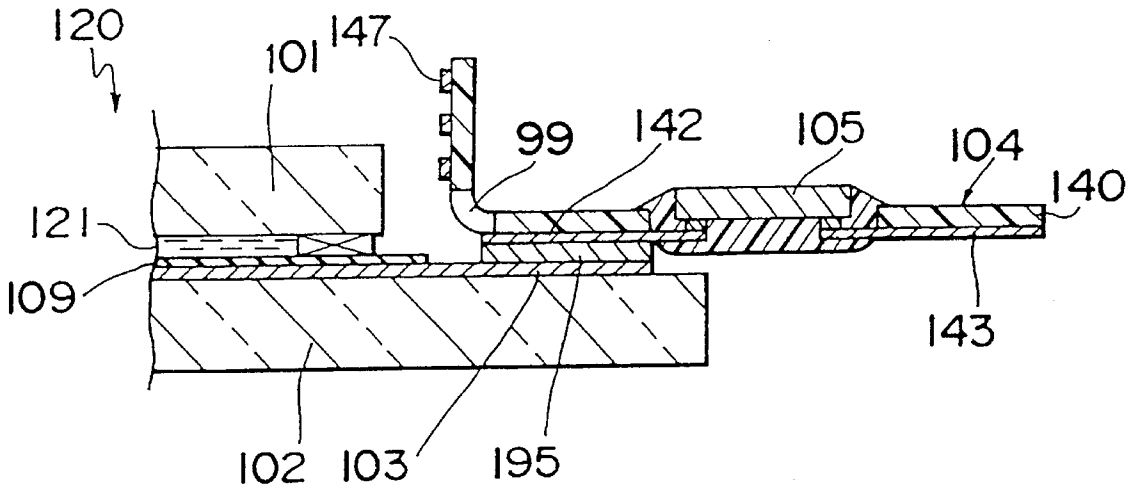
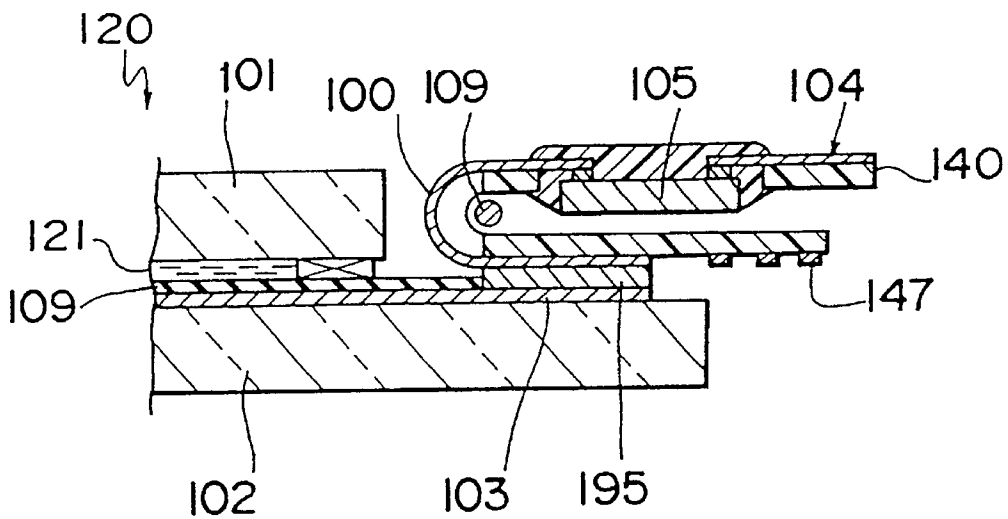

Fig. 16



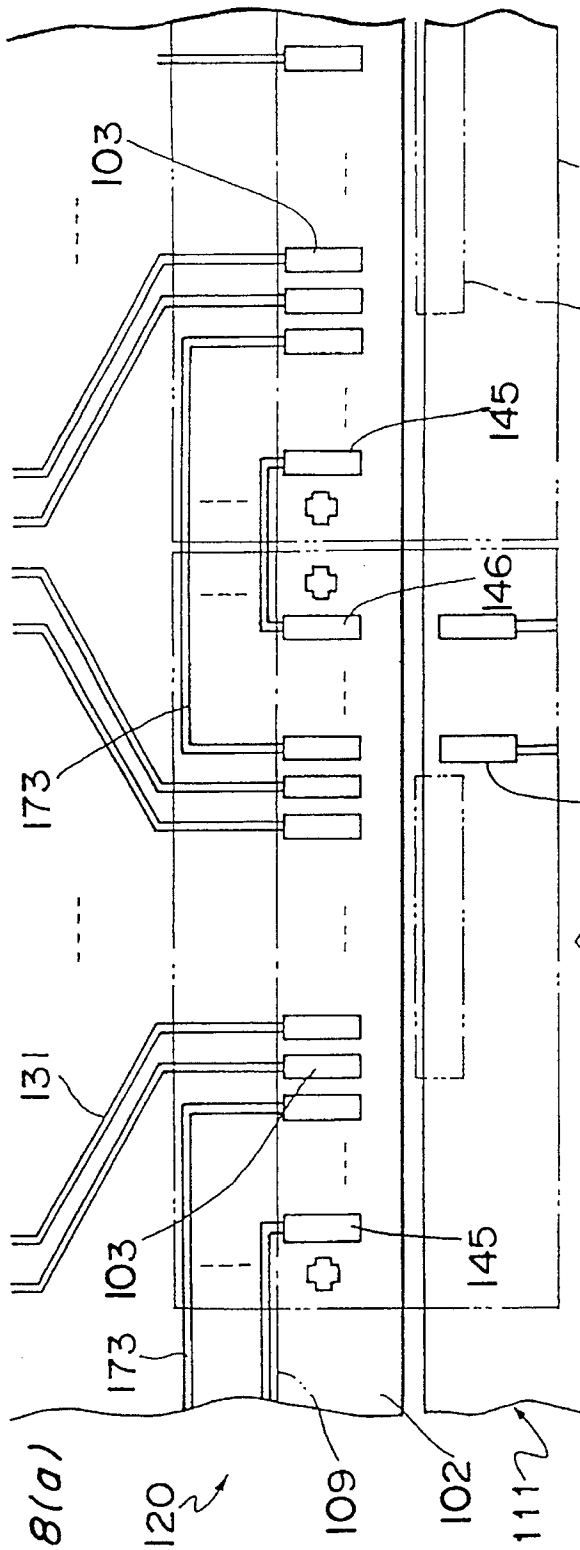

Fig. 18(a)

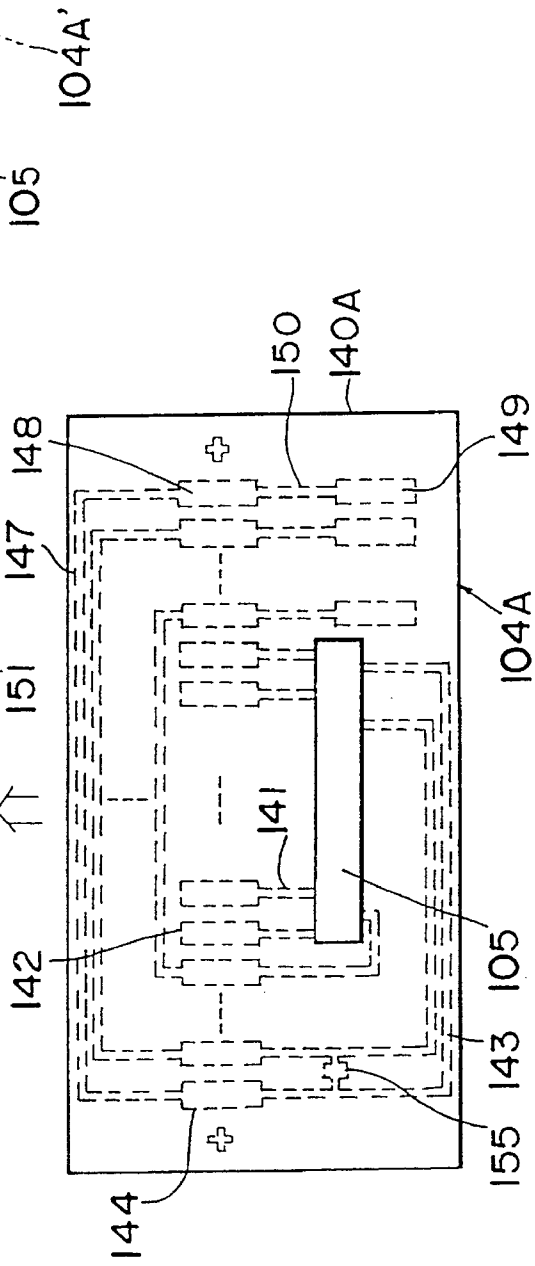
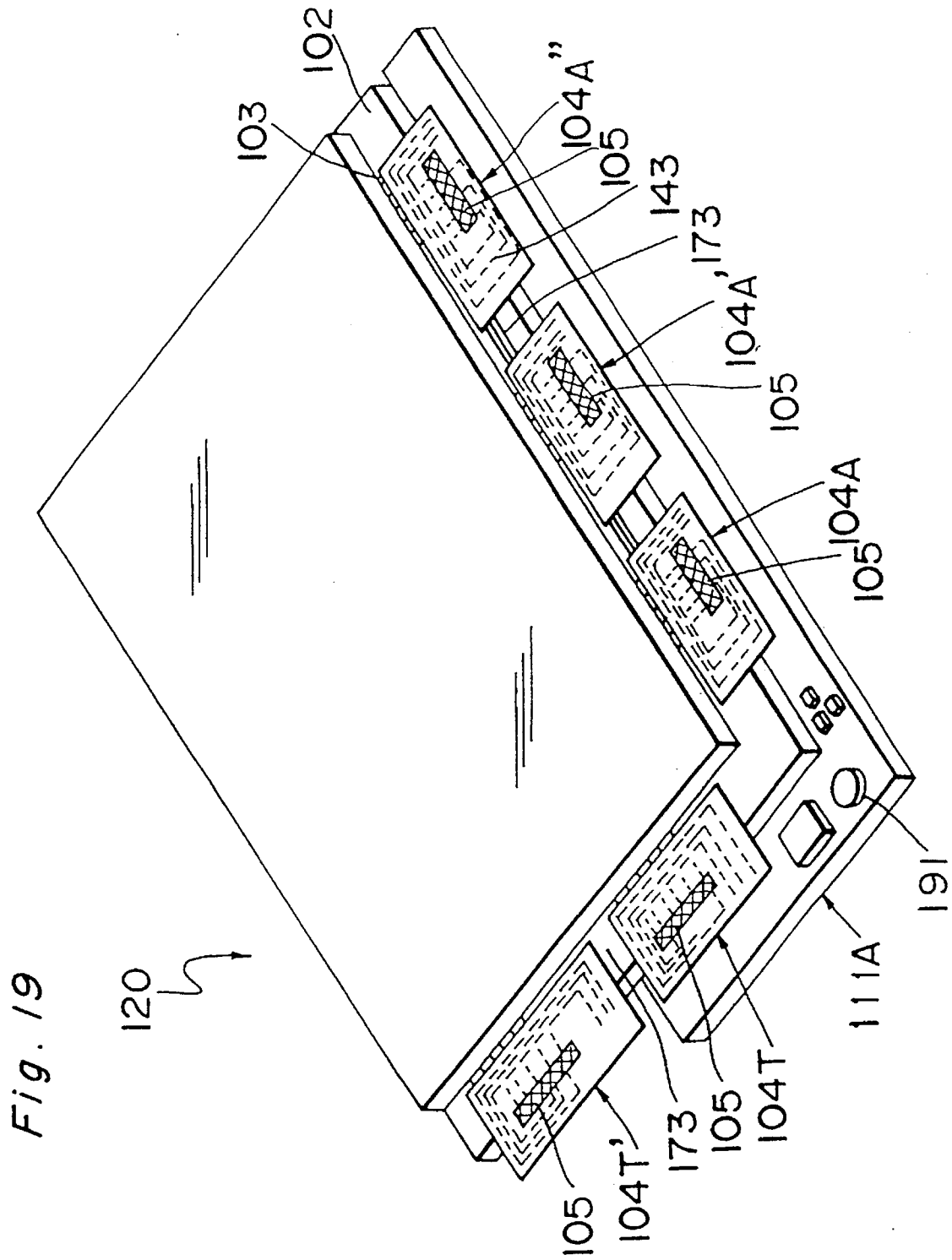

Fig. 18(b)



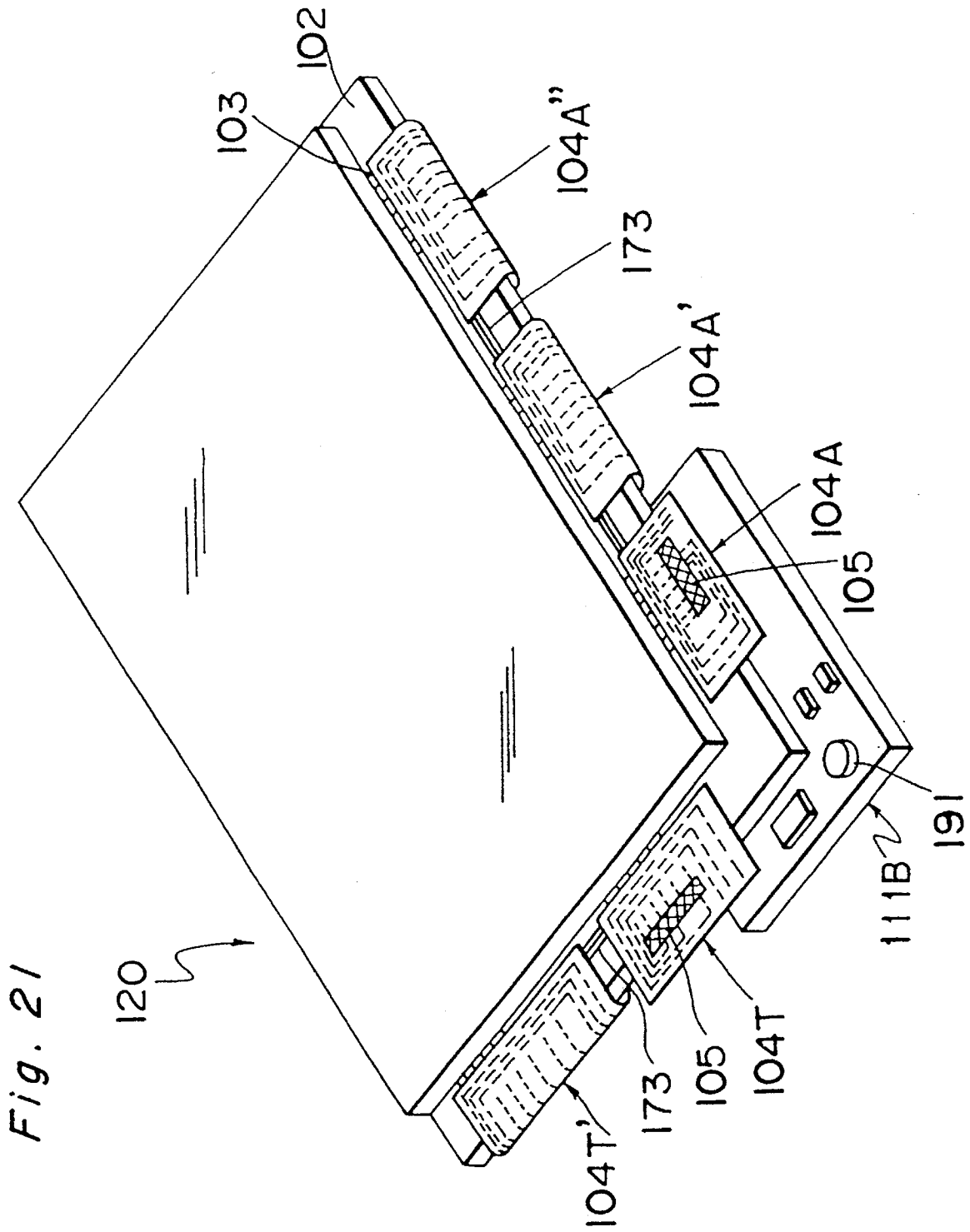

Fig. 22

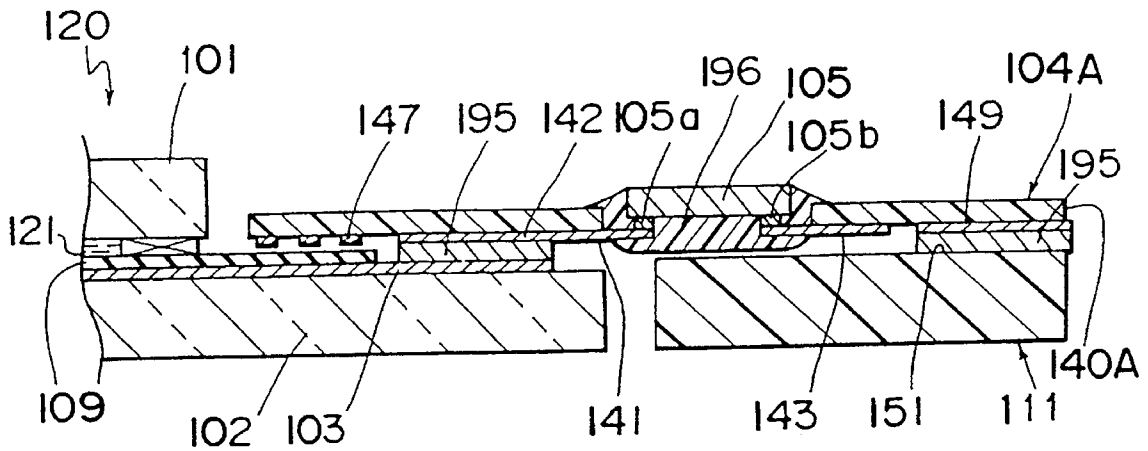

Fig. 23

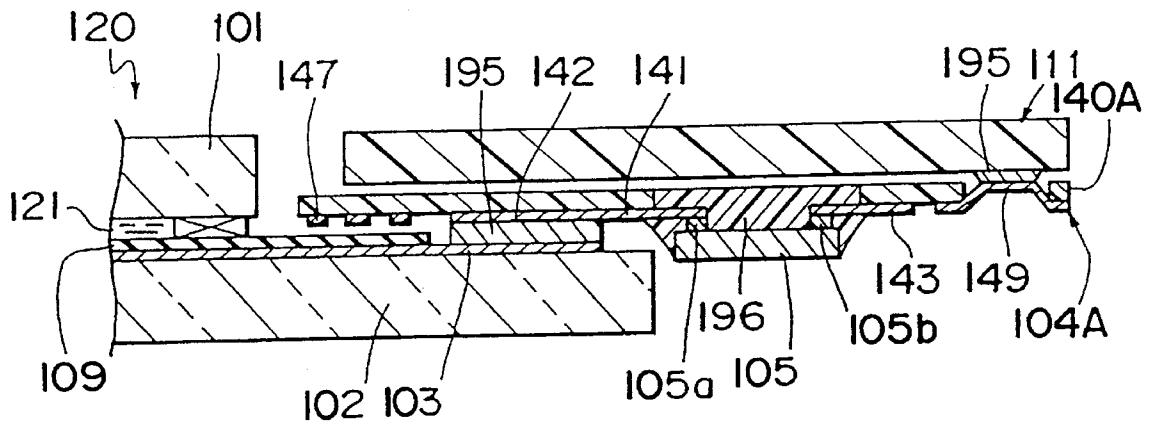

Fig. 24

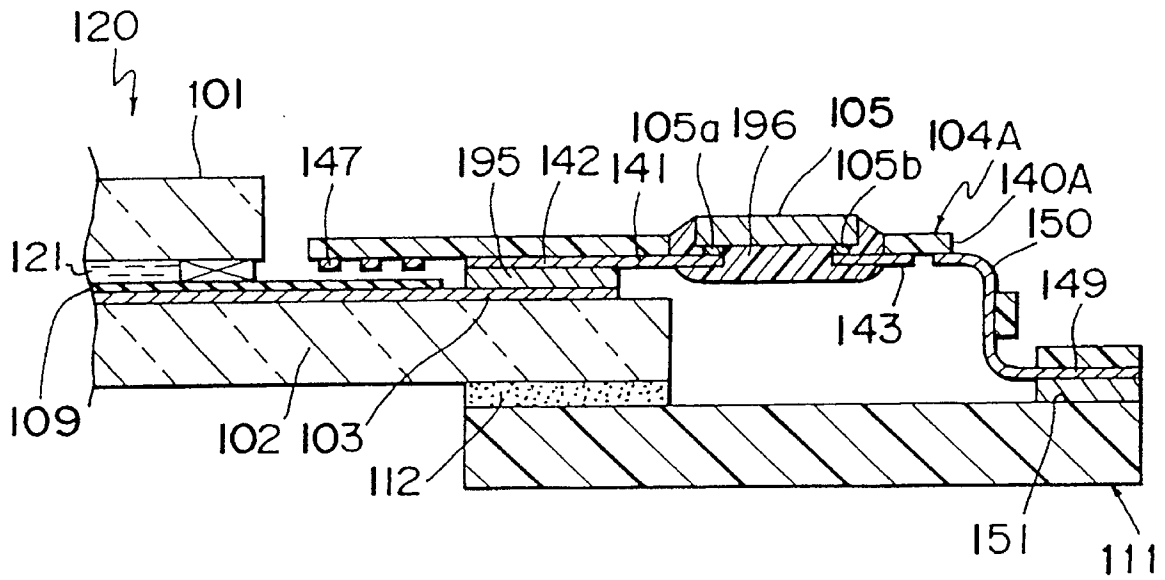

Fig. 25

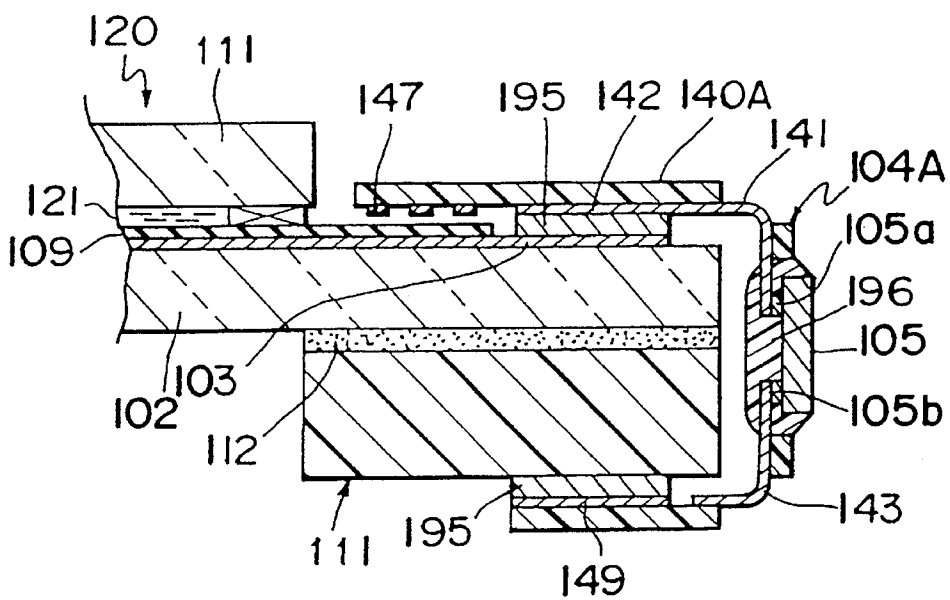

Fig. 28

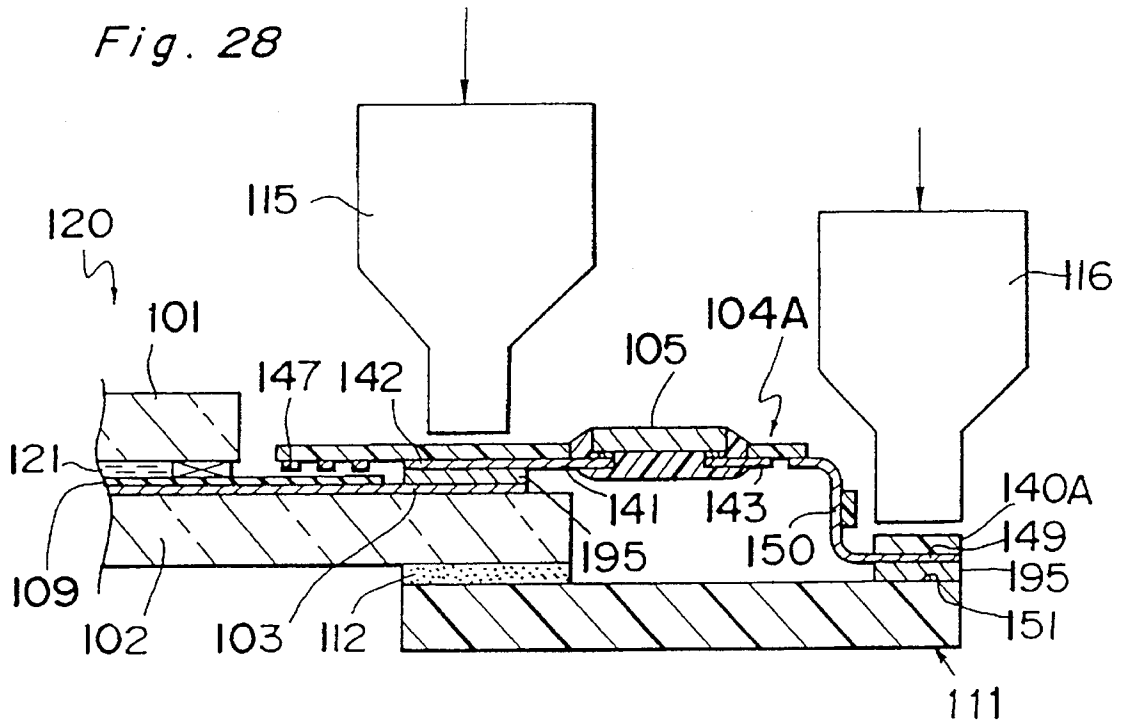

Fig. 29

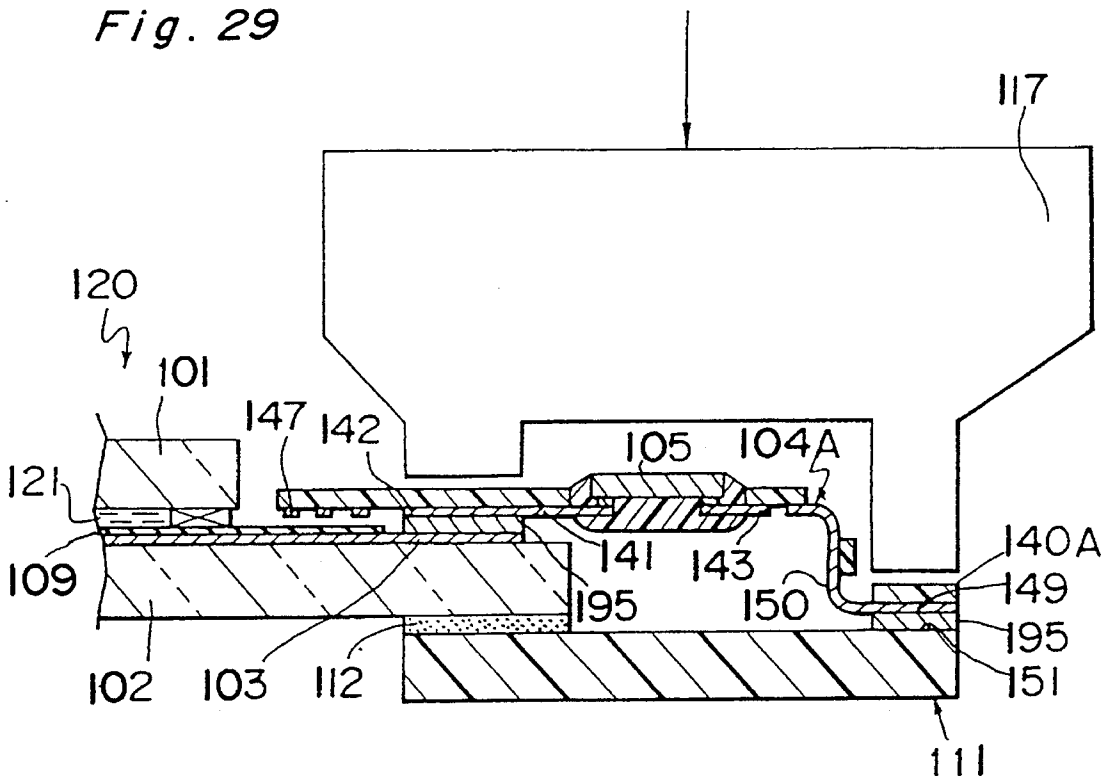

Fig. 30

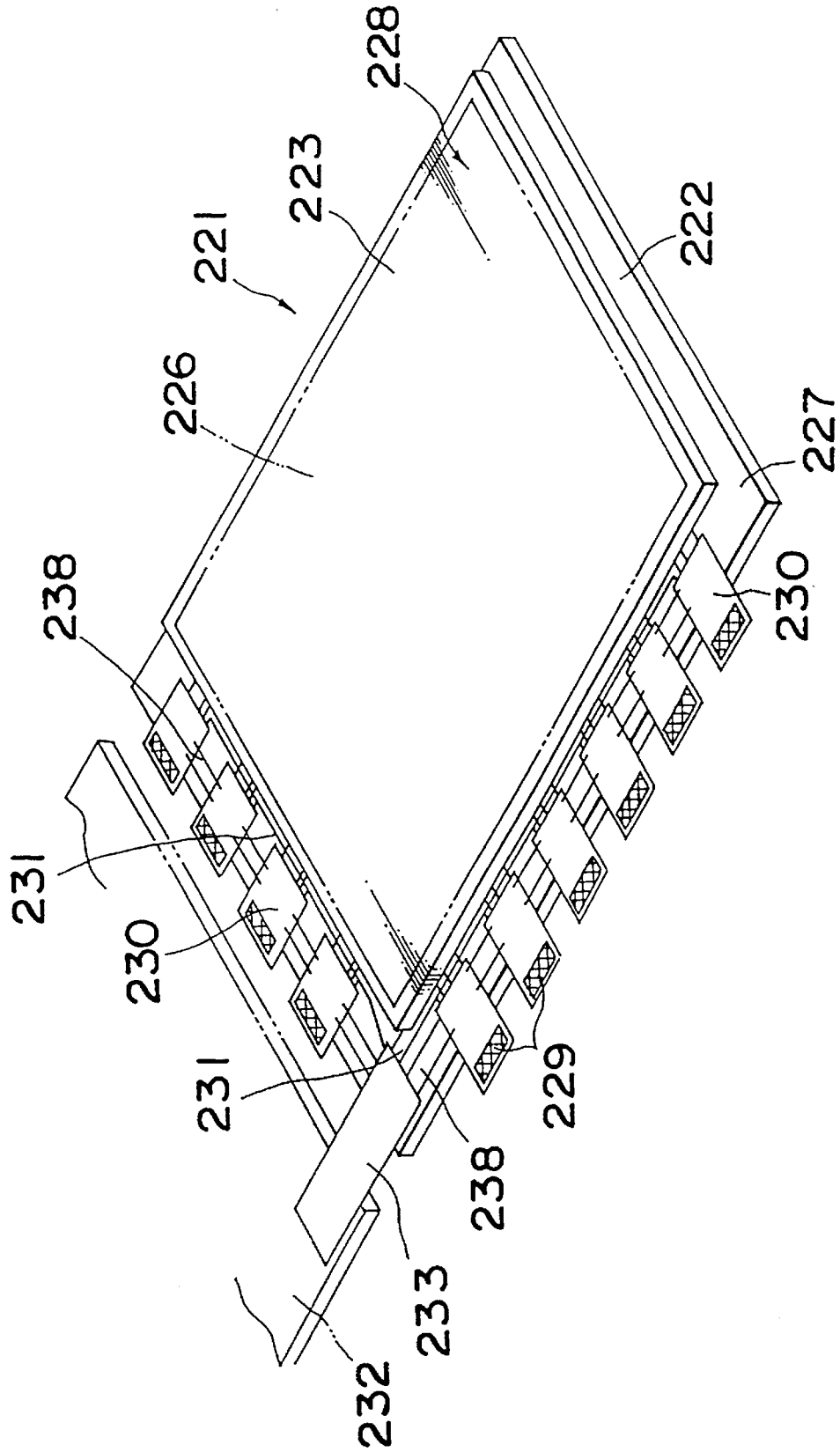

Fig. 32

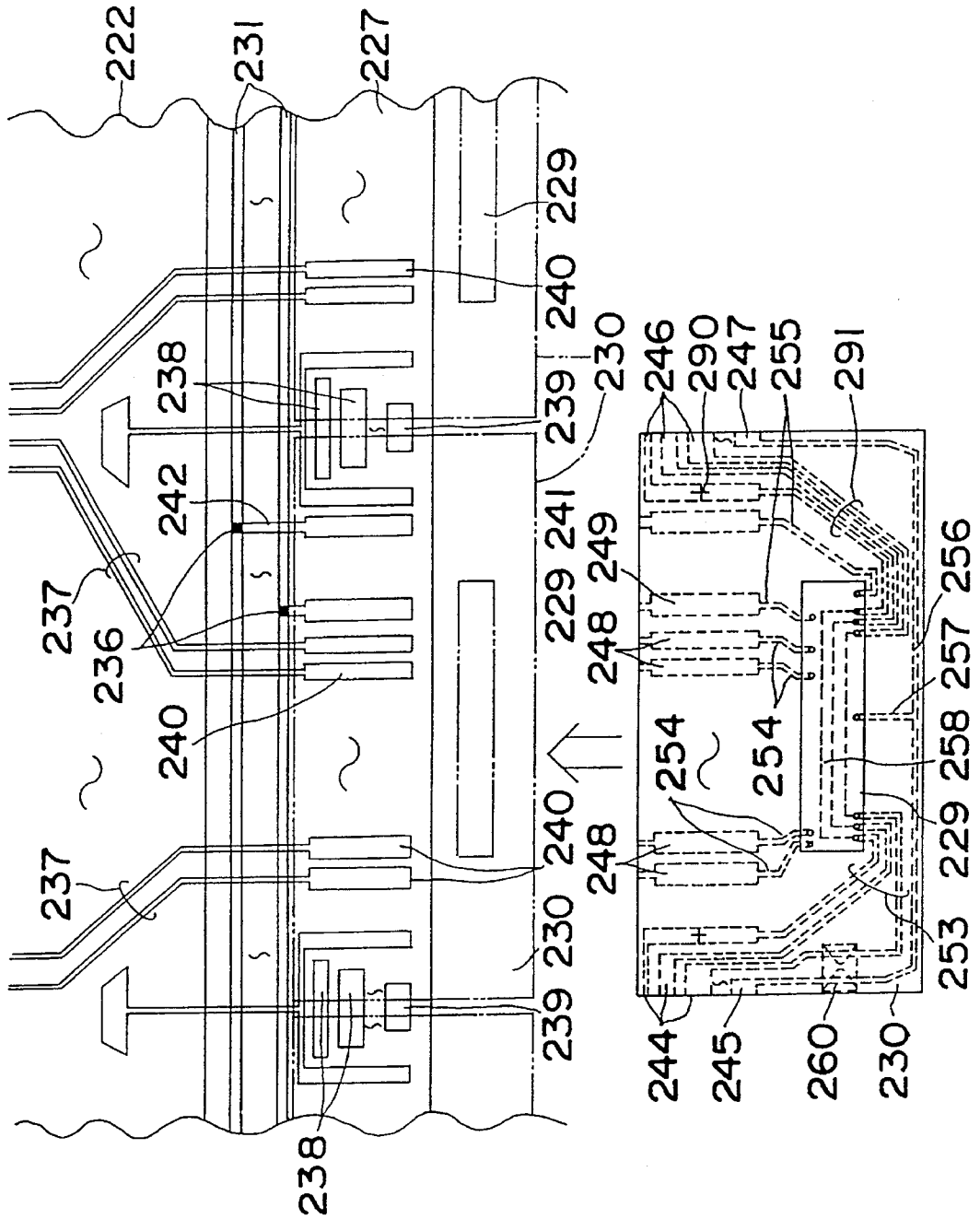

Fig. 33

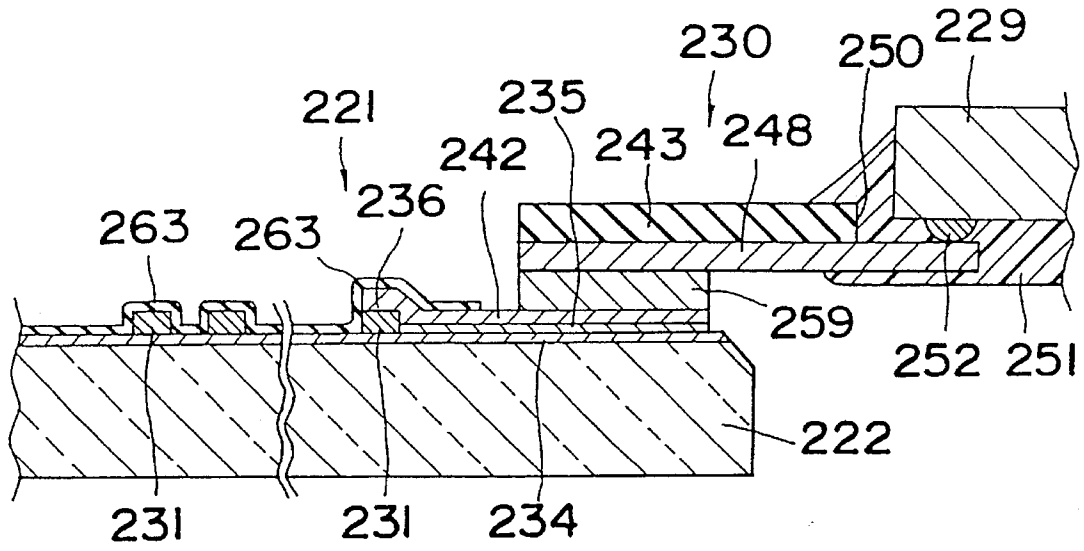

Fig. 34

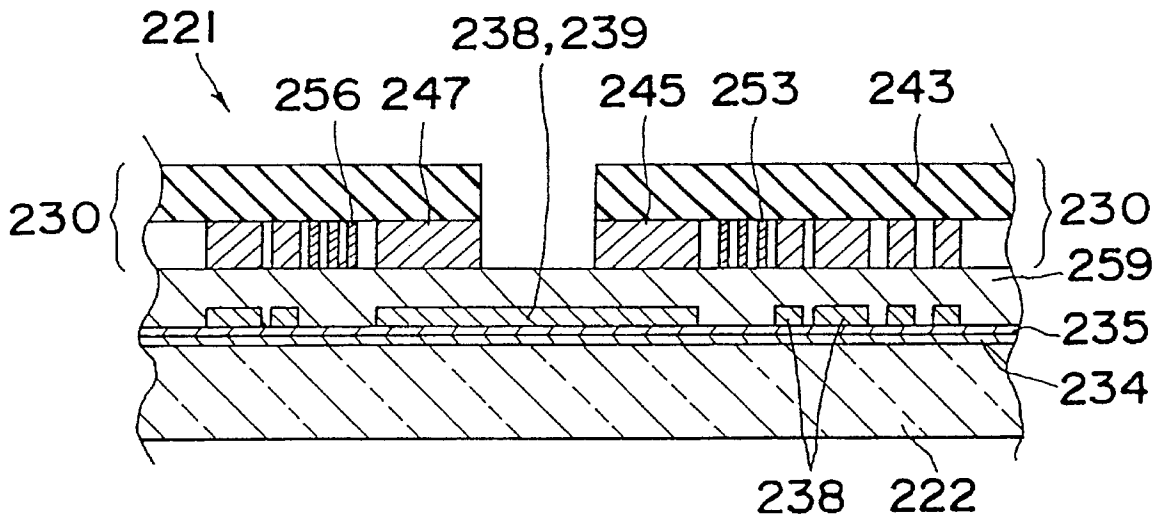

Fig.35

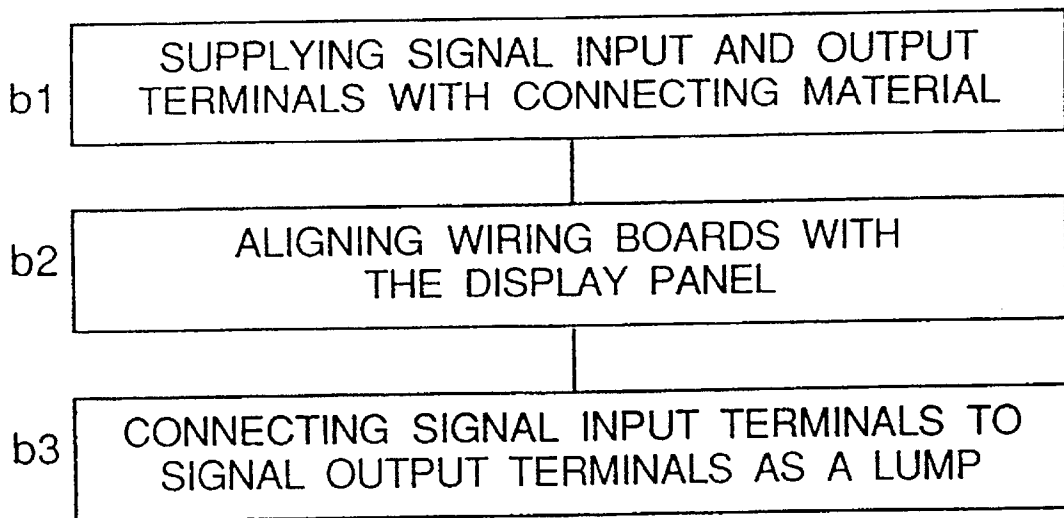

Fig. 36

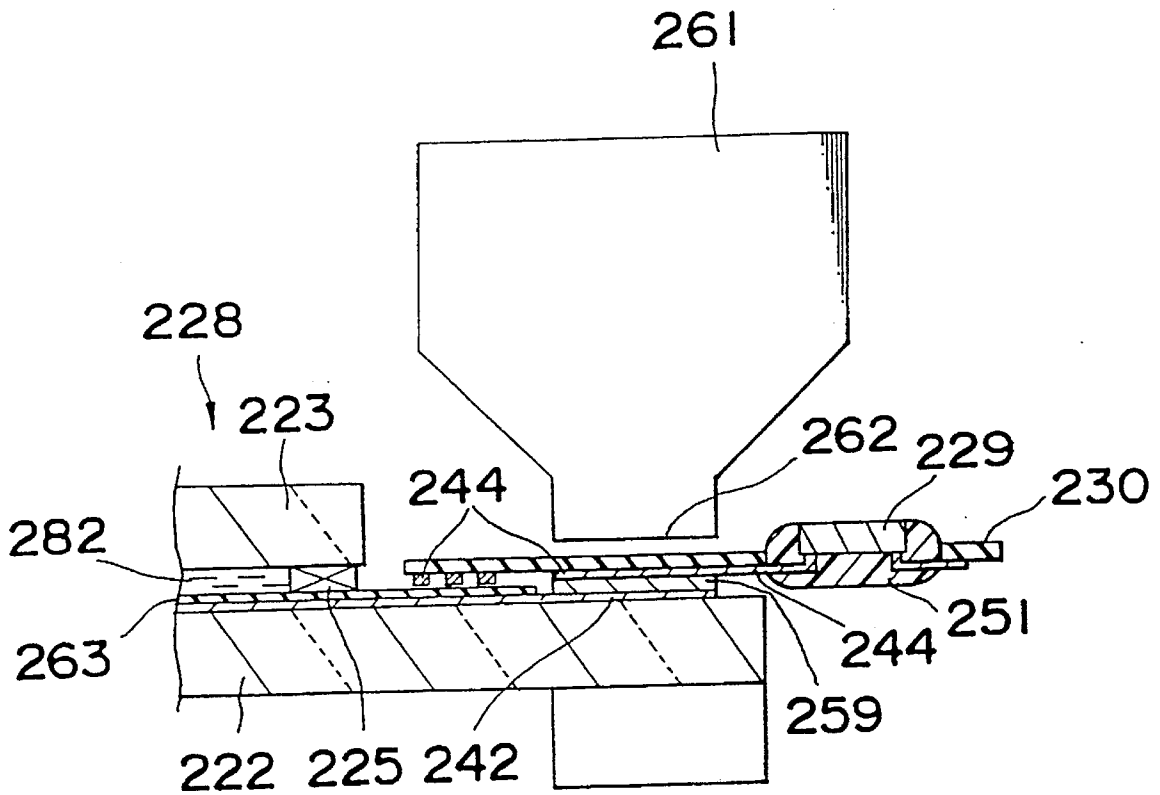

Fig. 37

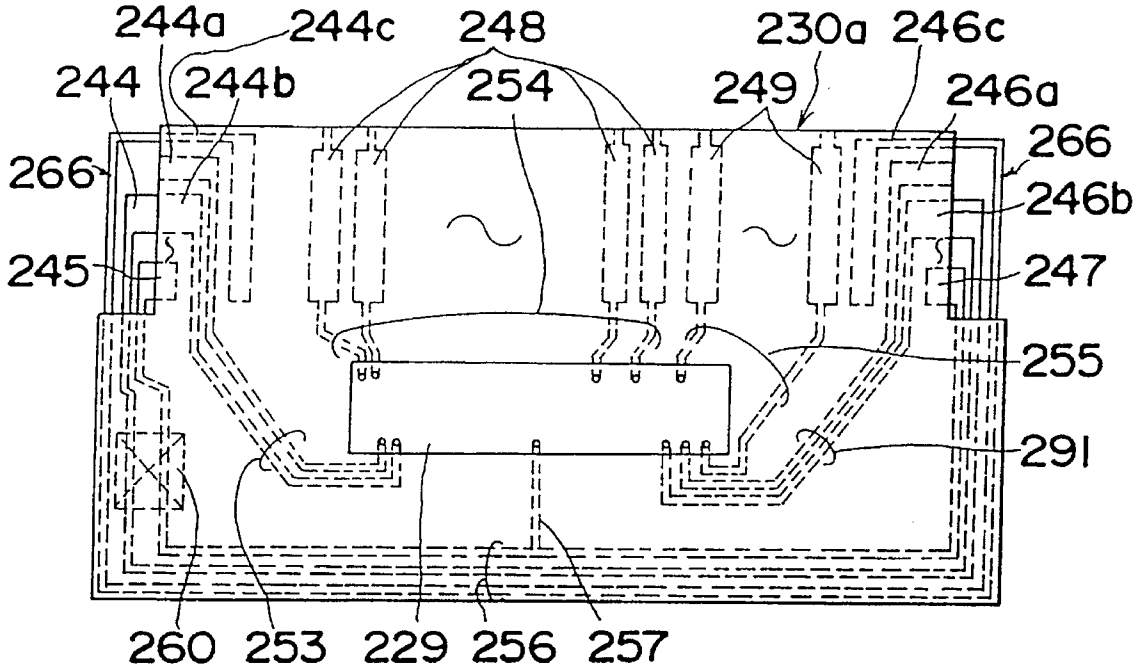

Fig. 38

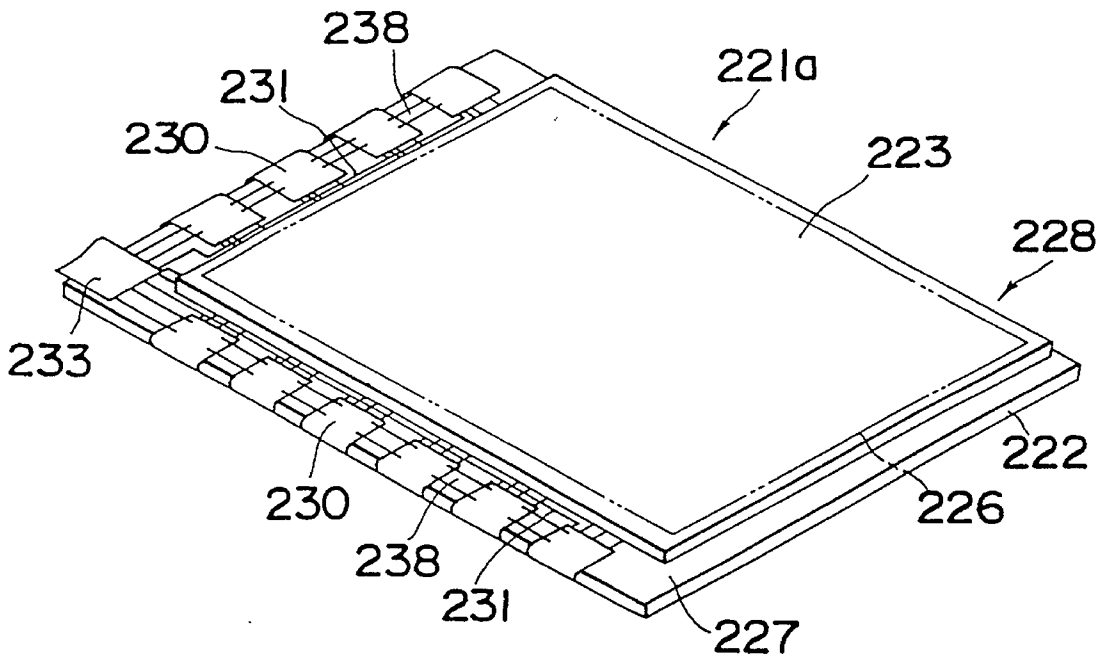

Fig. 39

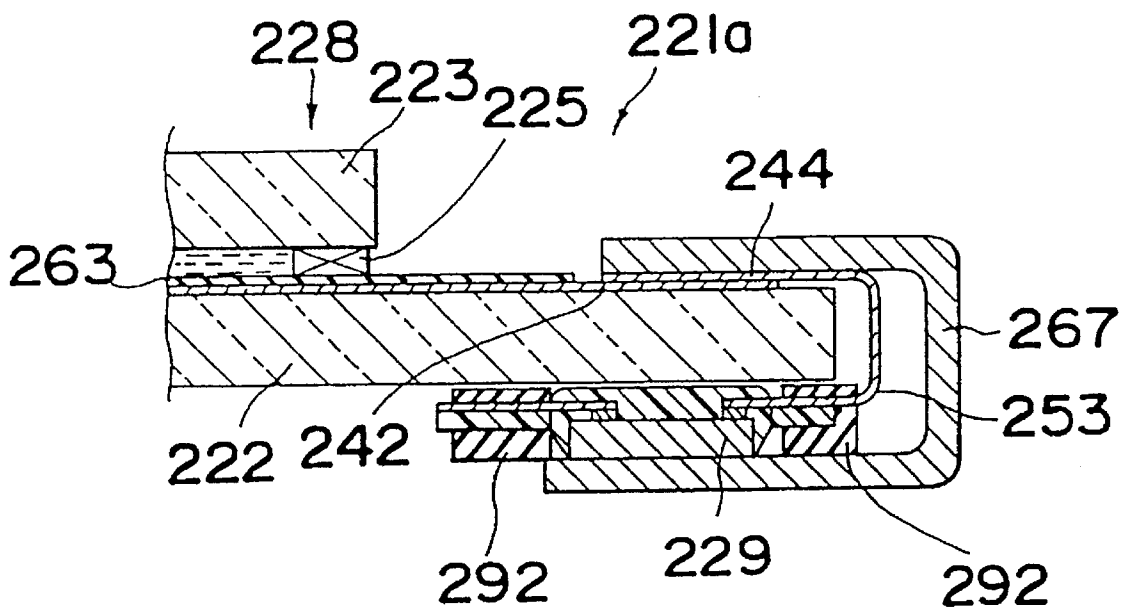

Fig. 40

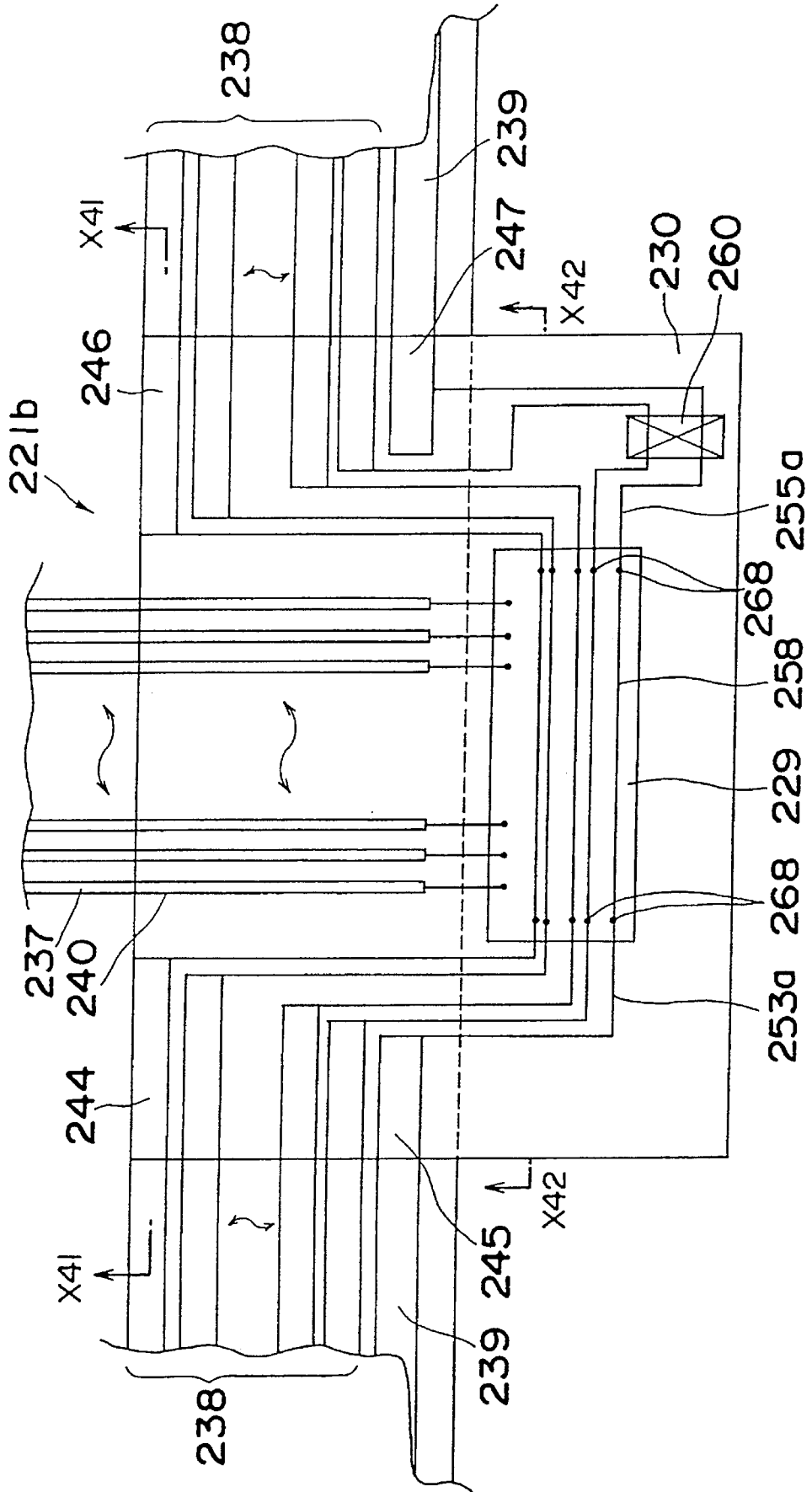

Fig. 41

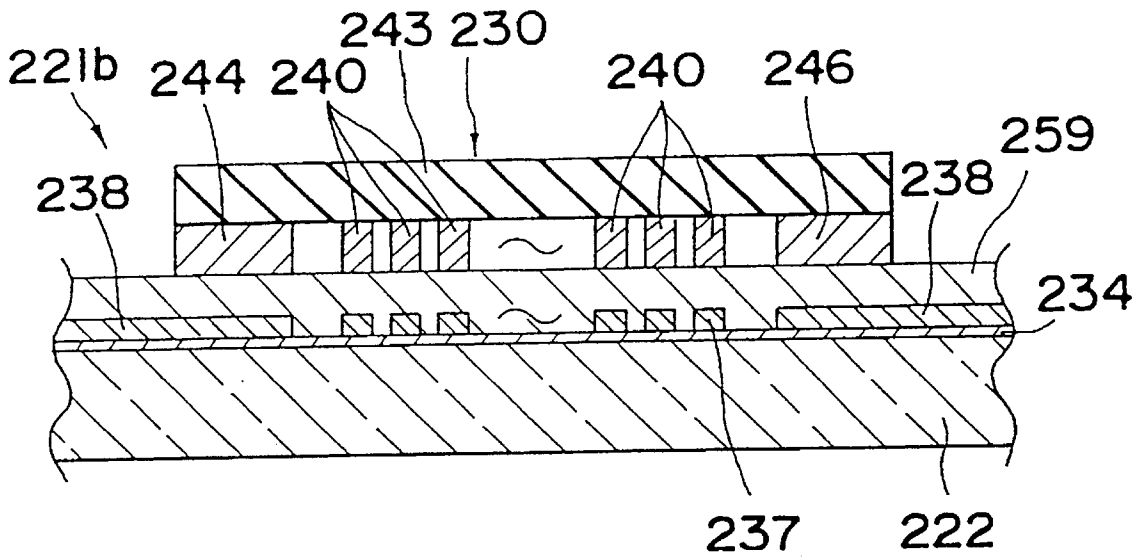

Fig. 42

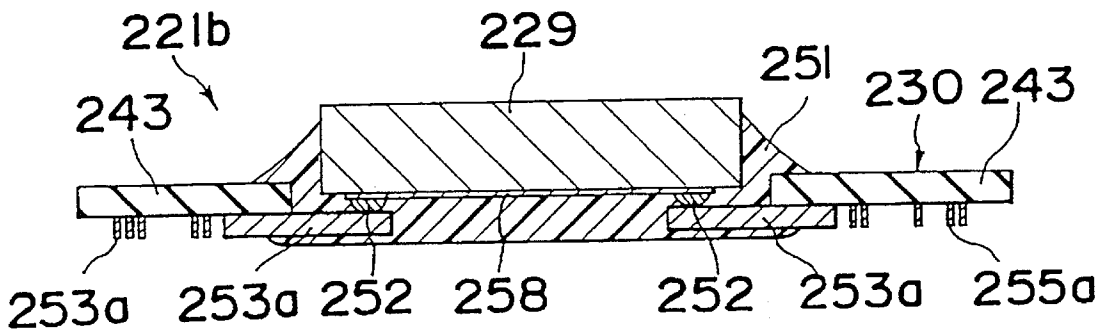

Fig. 44

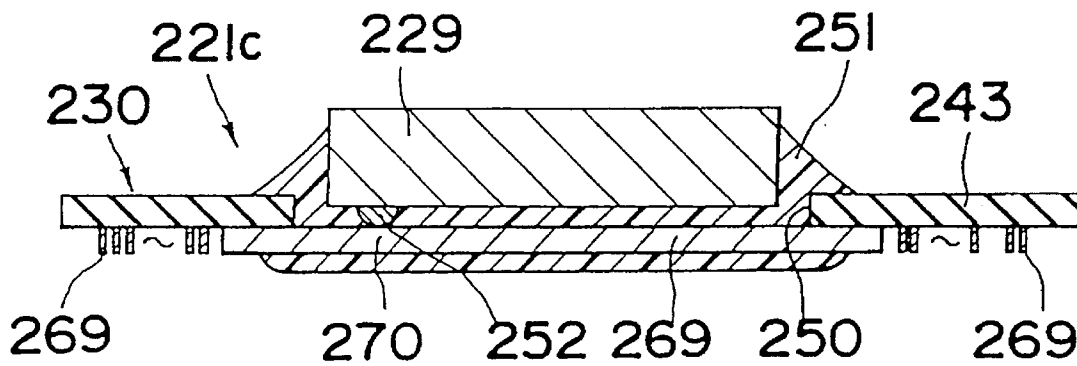

Fig. 45

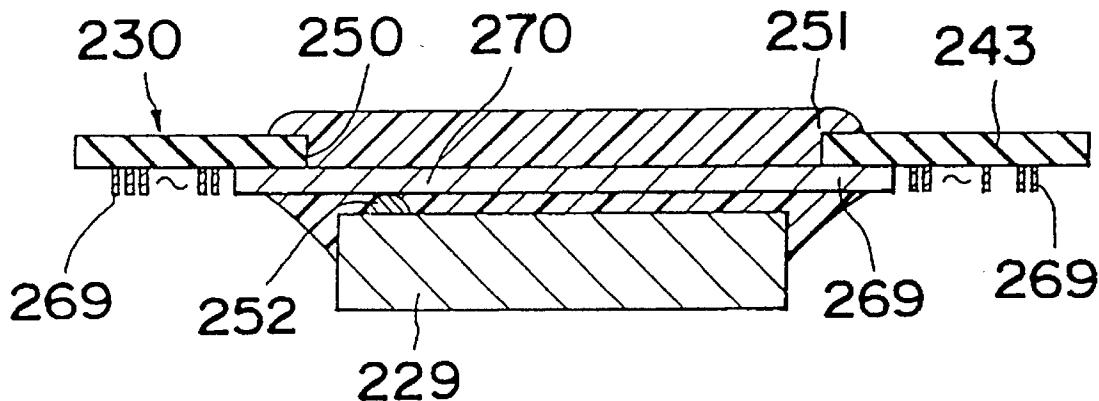

Fig. 46

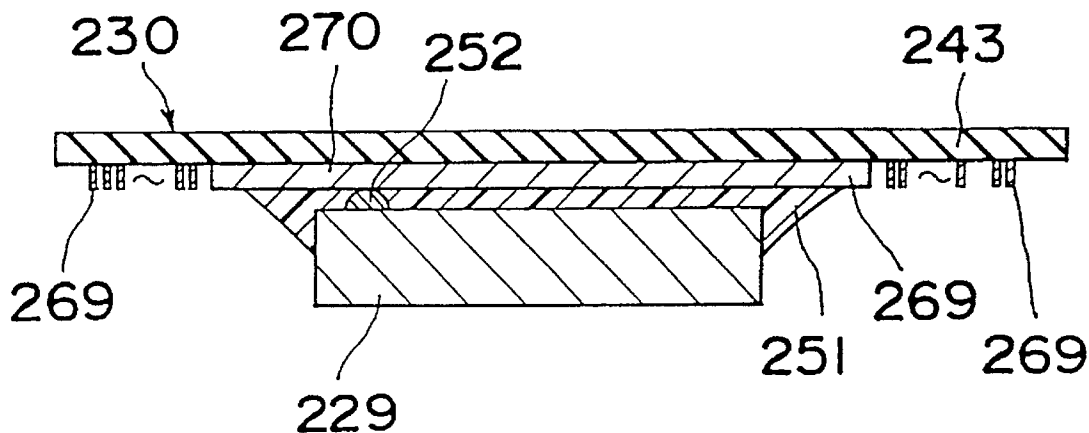

Fig. 48

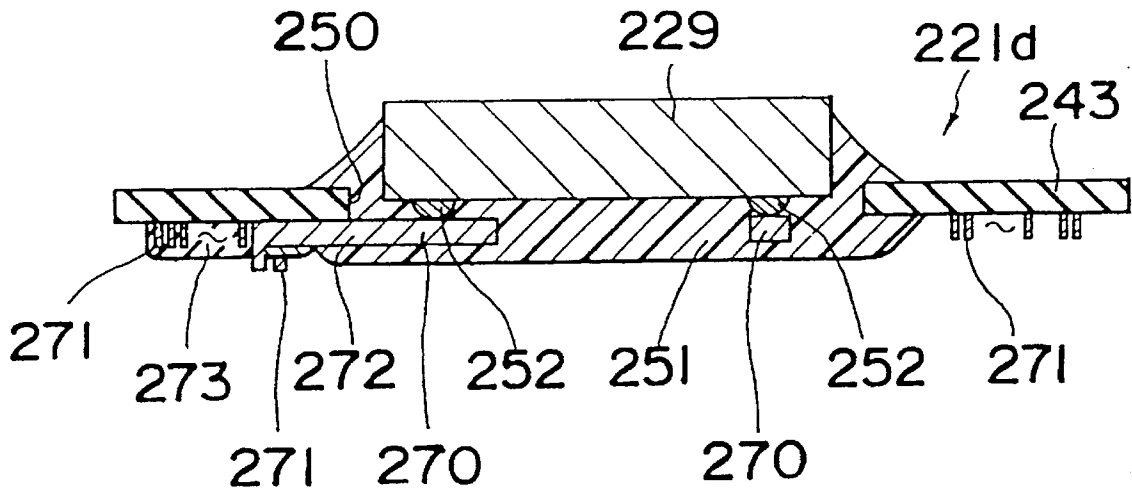

Fig. 50

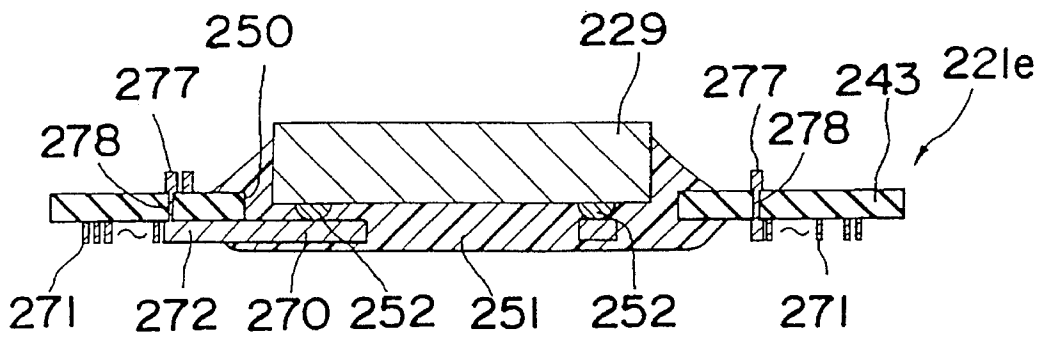

Fig. 51

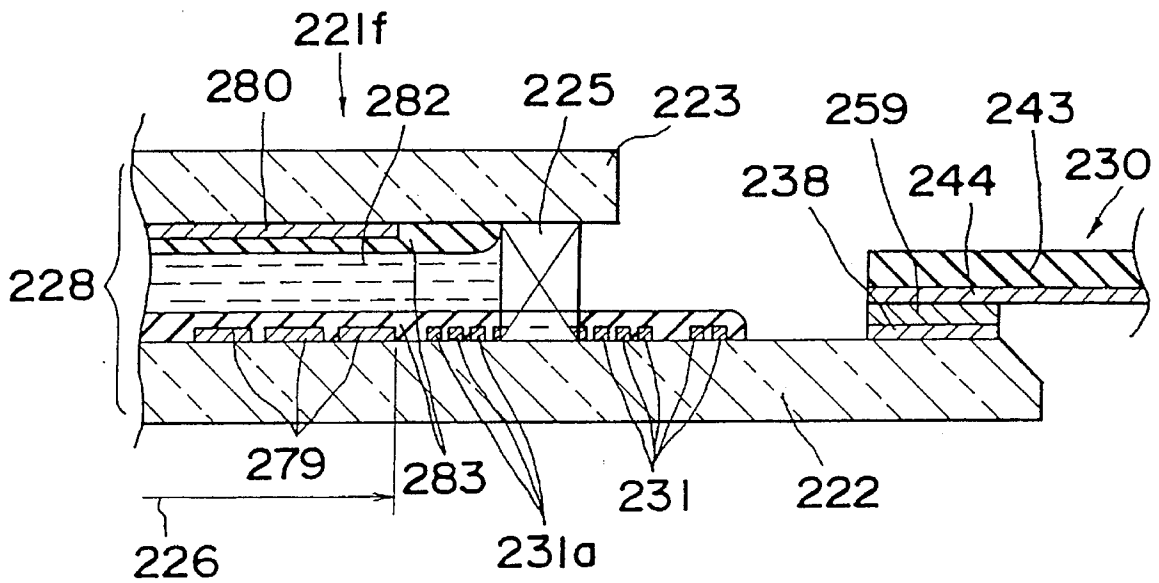

Fig. 52

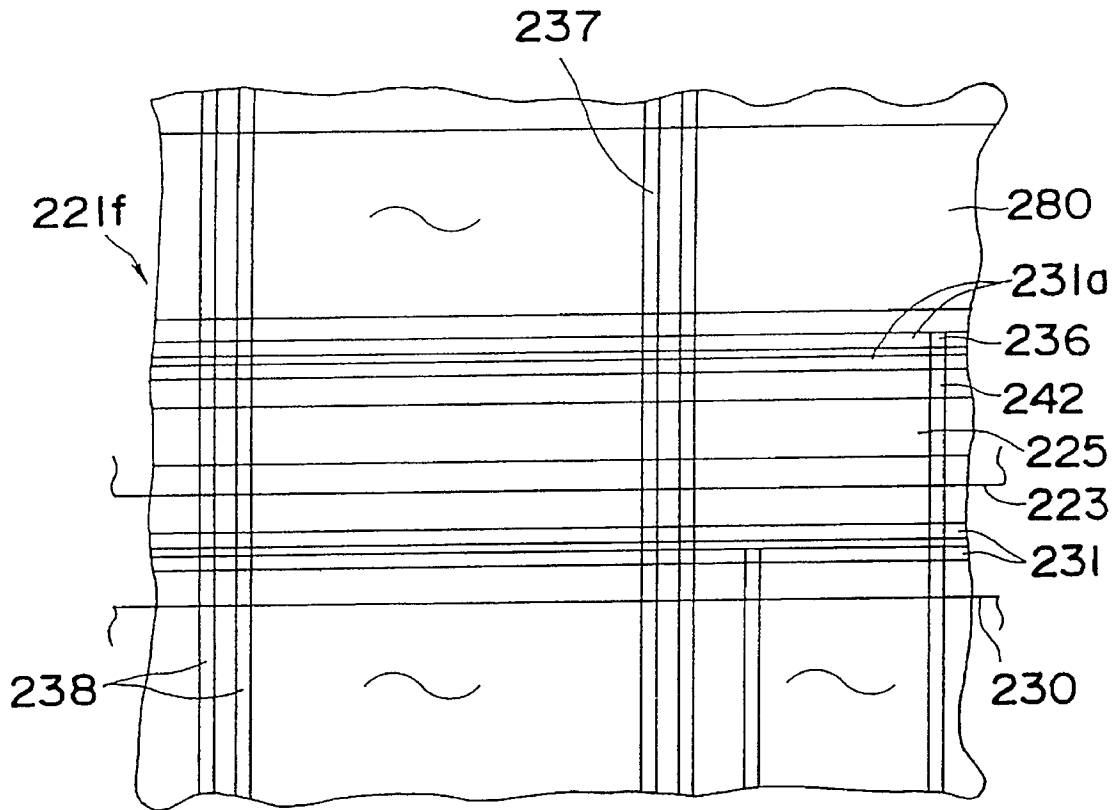

Fig. 53

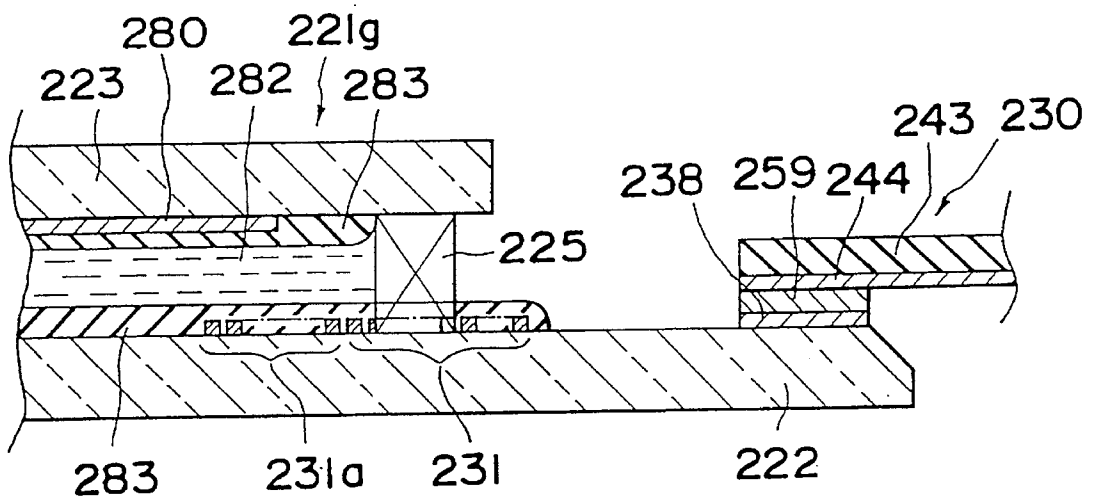

Fig. 54

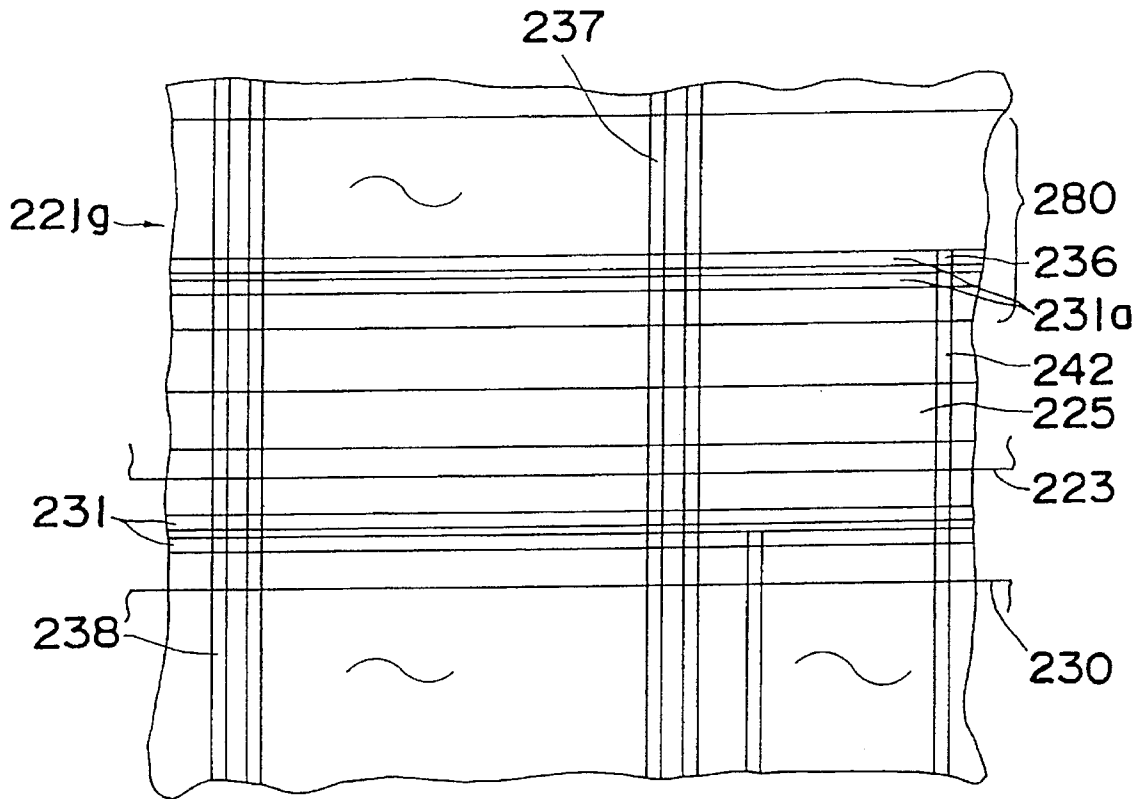
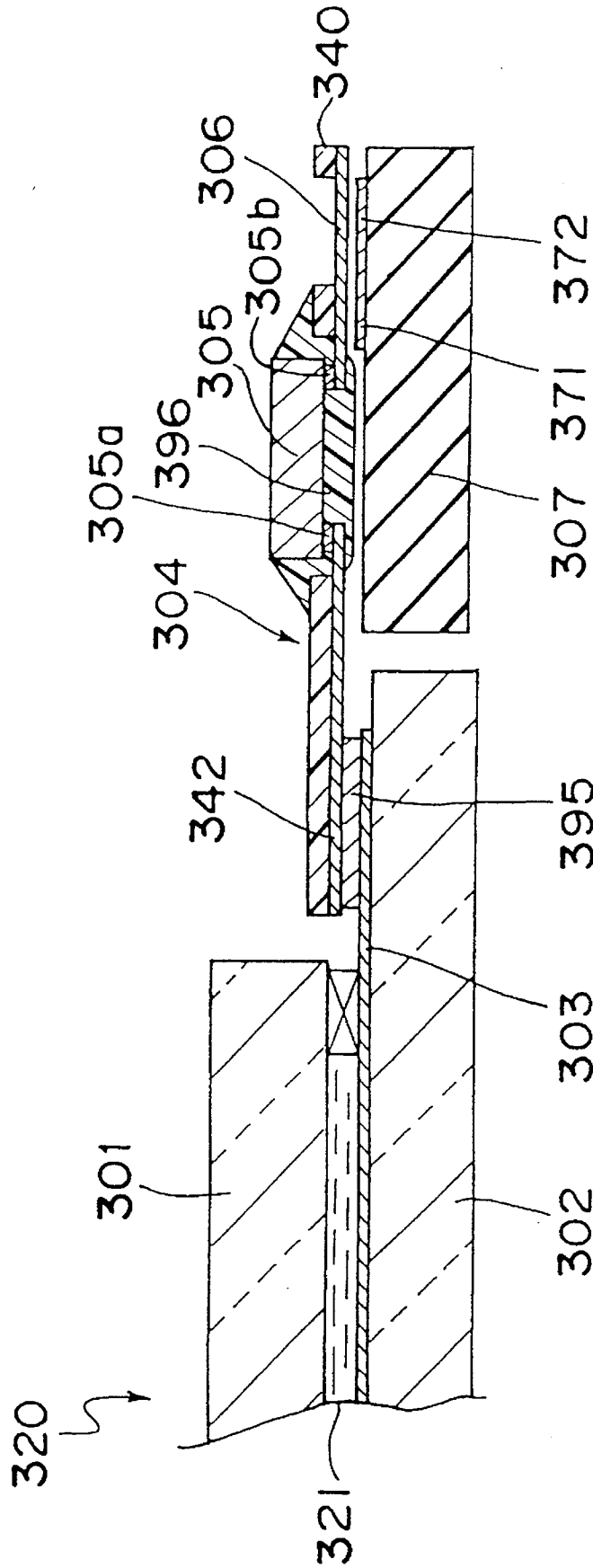

Fig. 56 PRIOR ART



**ASSEMBLY STRUCTURE OF A FLAT TYPE
DEVICE INCLUDING A PANEL HAVING
ELECTRODE TERMINALS DISPOSED ON A
PERIPHERAL PORTION THEREOF AND
METHOD FOR ASSEMBLING THE SAME**

BACKGROUND OF THE INVENTION

1. Field of the Invention

The present invention relates to an assembly structure of a flat type device and method for assembling the same. More specifically, the invention relates to an assembly structure of a flat type device including a panel having electrode terminals disposed on a peripheral portion thereof, such as liquid crystal, EL, plasma, and other panels.

2. Description of the Prior Art

Among various types of panels, a liquid crystal panel is described here. As shown in FIGS. 55 and 56, which are perspective and sectional views of a prior art, a liquid crystal panel 320 is in general so structured that liquid crystals 321 are sealed in between a pair of glass substrates 301, 302 and a large number of electrode terminals 303 are disposed on a peripheral portion of one glass substrate 302. FIG. 56 shows a section as viewed along the line A-A' in FIG. 55. In its assembled state, the liquid crystal panel 320 has on a peripheral portion thereof: flexible wiring boards 304, 304', . . . each having a drive IC 305 mounted thereon for driving the liquid crystal panel 320; a generally L-shaped common wiring board 307 for receiving signals from external; and a generally rectangular control board 311 for feeding signals to the common wiring board through a connector 308 (the assembled panel is referred to as a "module"). As shown in FIG. 55, the common wiring board 307 has, on its one surface, a bus line (circuit wiring) 371, and electrode terminals 372 electrically conducting with the bus line 371 and corresponding to the flexible wiring boards 304, 304', . . . , respectively. As shown in FIG. 56, the flexible wiring board 304 has a wiring layer, which includes output terminals 342 and an input terminal 306, provided on a base material surface 340 having a flexibility. The drive IC 305 is connected to the wiring layer by bump electrodes 305a, 305b (numeral 396 denotes resin).

Conventionally, the glass substrate 302 and the common wiring board 307 are juxtaposed with the electrode terminals 303, 372 faced upward. Then the electrode terminals 303 and 372 are electrically connected to the output terminals 342 and input terminal 306 of the flexible wiring board 304 by means of an anisotropic conductive material 395 or solder (not shown), respectively. Also, as shown in FIG. 55, one end of the connector 308 is connected to the bus line 371 of the common wiring board 307, while the other end of the connector 308 is connected to a signal feed terminal (not shown) of the control board 311.

In operation, a signal is fed to the bus line 371 of the common wiring board 307 from the control board 311 via the connector 308. Sequentially through the bus line 371, the electrode terminal 372, and the input terminal 306, the signal is inputted to the drive IC 305 of the flexible wiring boards 304, 304', Then, the signal outputted by the drive IC 305 is applied to pixels through the output terminals 342 and the electrode terminals 303. Thus, the liquid crystal panel 320 is driven.

Recently, liquid crystal panels have been undergoing very severe competitive development, facing a demand for downsizing and weight reducing the liquid crystal panel modules.

However, the above-described conventional assembling structure has both the common wiring board 307 and the control board 311 disposed and spaced from each other on side portions of the liquid crystal panel 320, thus inevitably resulting in a rather large size module. Further, since two types of large components, the common wiring board 307 and the control board 311, are provided, the resulting module is increased in weight, making a difficulty for weight reduction. Still further, the number of parts is increased so that the material cost is also increased. Yet, since the number of times of connection process is large, the man-hour required is increased, causing higher cost, disadvantageously.

Also, the larger the number of parts and the size, the more the module is affected by external force. Besides, the larger the number of times of connection process, the more the rate of occurrence of defectives increases. For these and other reasons, the reliability of the module is deteriorated to a further problem.

SUMMARY OF THE INVENTION

The present invention has been developed with a view to substantially solving the above described disadvantages and has for its essential object to provide a structure and method for assembling a panel by which a panel having electrode terminals disposed on a peripheral portion thereof, typified by liquid crystal panels, can be assembled with small size, light weight, low cost, and high reliability.

In order to achieve the aforementioned object, an assembly structure according to a first aspect of the present invention is an assembly structure of a flat type device, in which a panel has a plurality of electrode terminals disposed along a peripheral portion of one surface thereof, a flexible wiring board on which a drive IC for driving the panel is mounted is electrically connected to the electrode terminals of the panel, and wherein a circuit wiring for transferring a signal fed from external is electrically connected to the flexible wiring board, the assembly structure comprising:

an arrangement of the peripheral portion of the panel where a circuit wiring is provided at a layer below the electrode terminals so as to extend along the peripheral portion and to be electrically insulated from the electrode terminals with an insulating layer interposed therebetween, and where a junction terminal is provided so as to conduct with the circuit wiring, to penetrate through the insulating layer at a specified place, and to share the same layer with the electrode terminals; and

an arrangement of one side of the flexible wiring board where an input terminal and output terminals leading to the drive IC are provided at places corresponding to the junction terminal and electrode terminals of the peripheral portion of the panel;

wherein the flexible wiring board is overlaid on the peripheral portion of the panel so that the junction terminal and electrode terminals of the peripheral portion of the panel are electrically connected to the input terminal and output terminals of the flexible wiring board, respectively.

In the assembly structure of the flat type device according to the first aspect of the present invention, in operation, a signal fed to the circuit wiring of the peripheral portion of the panel from external is inputted to the drive IC via the junction terminal and then the input terminal of the flexible wiring board. A signal outputted by the drive IC is fed to the

inside of the panel via the output terminals of the flexible wiring board and the electrode terminals of the peripheral portion of the panel. Thus, the panel is driven.

In the assembly structure of the flat type device according to the first aspect of the invention, the common wiring board, which would be disposed on a side portion of the panel in the prior art, is omitted. Accordingly, the size of the module is reduced compared with the prior art. Also, the number of parts is reduced so that the module is reduced in weight. Such reduction in the number of parts results in a reduction in the material cost. Yet, the junction terminal and electrode terminals of the panel are collectively connected to the input terminal and output terminals of the flexible wiring board by means of, for example, an anisotropic conductive material. This allows the connection process to be achieved at one time so that the man-hour required is reduced compared with the prior art and therefore the cost is also reduced. Further, based on the fact that the number of connection processes is reduced and that the panel and the common wiring board, which are larger components, are not coupled with each other by the flexible wiring board but integrated together, a high yield of the production process can be attained and products with higher reliability can be offered to the market.

As shown above, in the assembly structure according to the first aspect of the invention, the common wiring board, which would be disposed on a side portion of the panel in the prior art, can be omitted. Accordingly, the module can be reduced in size, compared with the prior art. Also, since the number of parts is reduced, the module can be reduced in weight. Such reduction in the number of parts allows the material cost to be reduced. Yet, the junction terminal and electrode terminals of the panel can be collectively connected to the input terminal and output terminals of the flexible wiring board by means of, for example, an anisotropic conductive material. This allows the connection process to be achieved at one time, so that the man-hour required can be reduced compared with the prior art. As a result, the cost can be reduced.

Further, the structure is that the input terminal and output terminals of the flexible wiring board are provided in series and that the panel and the circuit board, which are both larger components, are not coupled with each other by the flexible wiring board. This arrangement makes the resulting module less vulnerable to any external force. Also, the production yield is improved so that the cost can be reduced and the product reliability is enhanced.

When the electrode terminals of the peripheral portion of the panel are connected by means of an anisotropic conductive material, the anisotropic conductive material, which is the today's major material to be used for interconnection in liquid crystal panels, makes it possible to utilize the existing know-hows and equipment as they are. This leads to a less amount of new investment. Accordingly, conventional production techniques and commercially available or existing equipment may be easily employed.

When electronic components such as a chip capacitor and a resistor are mounted on the flexible wiring board, a compact module with an upgraded display can be made by reducing noise of signals inputted to the drive IC.

When a portion of the flexible wiring board that projects sideward of the peripheral portion of the panel is bent so as to be wound around the peripheral portion of the panel, the module can be further reduced in size.

When at least a region where the peripheral portion of the panel and the flexible wiring board overlap each other and the drive IC mounted on the flexible wiring board are covered with a specified protective resin, any harmful sub-

stances such as moisture, NaCl, and H₂S gas can be prevented from penetrating into the connecting points at which the junction terminal and electrode terminals of the peripheral portion of the panel are connected to the input terminal and output terminals of the flexible wiring board, respectively. Also, the drive IC is firmly fixed so that inner leads of the drive IC will not break, and that durability to vibrations and shocks is even enhanced as a whole. Accordingly, the panel is further improved in its reliability so as be usable under very severe conditions.

If the electrode terminals of the peripheral portion of the panel are press fitted by a clip alone made of a shape memorizing member having a U shape in section, any defective drive IC that has proved or occurred as such after assembling can be easily exchanged for a good drive IC (or a flexible wiring board having a good drive IC mounted thereon) without the need of removing the adhesive or other work.

Further, if the electrode terminals of the peripheral portion of the panel are press fitted by a shape memorizing member having a U shape in section after being once connected by an anisotropic conductive material or the like, then the module reliability can be further enhanced.

The assembling method according to a second aspect of the invention is a method for assembling a flat type device, in which a panel has a plurality of electrode terminals disposed along a peripheral portion of one surface thereof, a flexible wiring board on which a drive IC for driving the panel is mounted is electrically connected to the electrode terminals of the panel, and a circuit wiring for transferring a signal fed from external is electrically connected to the flexible wiring board, the method for assembling a flat type device comprising the steps of:

providing, on the peripheral portion of the panel, a circuit wiring at a layer below the electrode terminals so as to extend along the peripheral portion and to be electrically insulated from the electrode terminals with an insulating layer interposed therebetween, and providing a junction terminal so as to conduct with the circuit wiring, to penetrate through the insulating layer at a specified place, and to share the same layer with the electrode terminals;

providing, on one side of the flexible wiring board, an input terminal and output terminals leading to the drive IC at places corresponding to the junction terminal and electrode terminals of the peripheral portion of the panel;

aligning the junction terminal and the electrode terminals with the input terminal and the output terminals with the peripheral portion of the panel and the flexible wiring board opposed to each other; and

electrically connecting the junction terminal and the electrode terminals to the input terminal and the output terminals by means of an anisotropic conductive material.

In the method according to the second aspect of the invention, the junction terminal and electrode terminals of the peripheral portion of the panel are electrically connected to the input terminal and output terminals of the flexible wiring board by means of an anisotropic conductive material. Accordingly, the terminals are collectively connected so that the connection process can be achieved at one time. As a result, the man-hour required is reduced so that the cost lowers. Besides, by making the use of existing know-hows and equipment, new production facilities may be easily introduced with low cost.

The assembly structure according to a third aspect of the invention is an assembly structure of a flat type device, in

which a panel has a plurality of electrode terminals disposed along a peripheral portion of one surface thereof, a plurality of flexible wiring boards which have a wiring layer on a base material surface with a flexibility and on which a drive IC for driving the panel is mounted are electrically connected to the electrode terminals of the panel, and a circuit wiring for transferring a signal fed from external is electrically connected to the flexible wiring boards, the assembly structure comprising:

an arrangement of the peripheral portion of the panel where a first junction terminal and a second junction terminal corresponding to each one of the flexible wiring boards and sharing the same layer with the electrode terminals are provided on both sides of a group of the electrode terminals corresponding to each one of the flexible wiring boards in a direction along the peripheral portion of the panel, and where a first circuit wiring for connecting the second junction terminal corresponding to one of the flexible wiring boards to the first junction terminal corresponding to another flexible wiring board adjacent to the flexible wiring board is provided in proximity to a row formed by the various terminals; and

an arrangement on the flexible wiring boards where an input terminal, output terminals, and a third junction terminal formed of part of the wiring layer and leading to the drive IC are provided at places corresponding to the first junction terminal, electrode terminals, and second junction terminal of the peripheral portion of the panel, and where a second circuit wiring for connecting the input terminal to the third junction terminal is provided;

wherein the flexible wiring boards are overlaid on the peripheral portion of the panel so that the first junction terminal, electrode terminals, and second junction terminal of the peripheral portion of the panel are electrically connected to the input terminal, output terminals, and third junction terminal of each one of the flexible wiring boards in their respective correspondence.

In the assembly structure according to the third aspect of the invention, in operation, a signal is fed to the first circuit wiring of the peripheral portion of the panel from the external control board via the connector and the like. The signal is inputted to the drive IC from the first junction terminal via the input terminal of the flexible wiring board. A signal outputted by the drive IC is fed to the inside of the panel via the output terminals of the flexible wiring board and the electrode terminals of the peripheral portion of the panel. Thus, the panel is driven. Also, the signal is branched by the first junction terminal, passed sequentially through the second circuit wiring and third junction terminal of the flexible wiring board, the second junction terminal and first circuit wiring leading thereto of the peripheral portion of the panel, and thus fed to the first junction terminal corresponding to another flexible wiring board adjacent to the flexible wiring board. Then the signal is inputted to the drive IC from the first junction terminal via the input terminal of the adjacent flexible wiring board. A signal outputted by the drive IC is fed to the inside of the panel via the output terminals of the adjacent flexible wiring board and the electrode terminals of the peripheral portion of the panel. In this way, the signal is fed to the electrode terminals corresponding to an adjacent flexible wiring board one after another.

In the assembly structure of the flat type device according to the third aspect of the invention, the common wiring

board, which would be disposed sideward of the panel in the prior art, is omitted. Accordingly, the module can be reduced in size compared with the prior art. Also, the number of parts is reduced so that the weight of the module is reduced. Such reduction in the number of parts allows a reduction in material cost. Yet, the first junction terminal, electrode terminals, and second junction terminal of the peripheral portion of the panel are collectively connected to the input terminal, output terminals, and third junction terminal of the flexible wiring board by means of, for example, an anisotropic conductive material. Also, the process of connection between the flexible wiring boards and the common wiring board does not exist (the control board is connected to the first circuit wiring of the peripheral portion of the panel via a connector as in the prior art). Accordingly, the man-hour required is reduced so that the cost lowers.

Further, since a smaller number of parts are involved and the module size is also small, or since a smaller number of times of connection is involved, the module is less affected by any external force so that the rate of occurrence of defectives lowers, accompanied by other advantages. As a result, the module reliability is enhanced.

When a portion of the flexible wiring boards that projects sideward of the peripheral portion of the panel is bent so as to be wound around the peripheral portion of the panel, the module size is further reduced.

When a slit is provided to the base material surface of the portion, at which the flexible wiring boards are wound, in a direction along the peripheral portion of the panel, the flexible wiring boards can be more easily bent around the winding portion, so that the module becomes easier to assemble.

When a clip made of a shape memorizing member having a U shape in section is provided to pinch the peripheral portion of the panel on outside of each one of the flexible wiring boards so that a group of the electrode terminals corresponding to each one of the flexible wiring boards are press fitted, the corresponding terminals can be easily connected to each other. Moreover, any flexible wiring board on which a defective IC that has proved or occurred as such after assembling is mounted can be easily exchanged for new one without the need of removing the adhesive or other work.

When a slit is provided to the base material surface of a portion of each one of the flexible wiring boards that corresponds to a spacing between the row of the input terminal, the output terminals and the third junction terminal, and the second circuit wiring so as to extend along the spacing, the slit, being close to the terminals, allows any excess of the material that connects the corresponding terminals to each other to easily flow therethrough more evenly among the terminals without being affected by the second circuit wiring pattern and the like. As a result, the insulating property between the connecting terminals of the flexible wiring board and the first or second circuit wiring can be readily retained. Further, the conditions that result after connection among the connecting terminals become uniform so that a stabler reliability of the module can be attained.

When the base material surface has been removed at a portion of the flexible wiring boards that corresponds to the input terminal, the output terminals, or the third junction terminal, a proper terminal for performance tests can be put in contact with the terminals through the portion where the base material surface has been removed, while the flexible wiring board is connected to the peripheral portion of the panel. As a result, performance tests for the panel and the drive ICs can be easily performed.

When the flexible wiring boards are overlaid on the peripheral portion of the panel in such a way that the row of the input terminal, the output terminals and the third junction terminal is located outer than the second circuit wiring, and when a portion of the flexible wiring boards that corresponds to the second circuit wiring is bent substantially 90 degrees to substantially 180 degrees with respect to the portions corresponding to the various terminals, then the width of the peripheral portion of the panel is required only to be equivalent to the portions corresponding to the terminals, so that the width of the peripheral portion of the panel can be designed narrow. As a result, the module size can be further reduced.

When the flexible wiring boards are overlaid on the peripheral portion of the panel in such a way that the row of the input terminal, the output terminals and the third junction terminal is located inner than the second circuit wiring, and when a portion of the flexible wiring boards on one side of the row of the various terminals opposite to the side on which the second circuit wiring is located is bent substantially 90 degrees to substantially 180 degrees with respect to the portions corresponding to the various terminals, then the width of the peripheral portion of the panel is required only to be equivalent to the portions corresponding to the terminals so that the width of the peripheral portion of the panel can be designed narrow. As a result, the module size can be further reduced.

When the drive IC is mounted on a portion of each one of the flexible wiring boards at which the flexible wiring boards are bent, the extent in which the flexible wiring boards project sideward of the peripheral portion of the panel is reduced by an extent of the width of the drive IC. As a result, the module size can be further reduced.

Further, when electronic components such as a capacitor and a resistor are mounted on the flexible wiring boards, measures for noise involved in the input signal line and the like can be easily implemented in a compact-mounting structure. As a result, a compact module of high display grade can be realized.

The assembling method according to a fourth aspect of the invention is a method for assembling a flat type device, in which a panel has a plurality of electrode terminals disposed along a peripheral portion of one surface thereof, a plurality of flexible wiring boards which have a wiring layer on a base material surface with a flexibility and on which a drive IC for driving the panel is mounted are electrically connected to the electrode terminals of the panel, and a circuit wiring for transferring a signal fed from external is electrically connected to the flexible wiring boards, the method for assembling a flat type device comprising the steps of:

providing, on the peripheral portion of the panel, a first junction terminal and a second junction terminal corresponding to each one of the flexible wiring boards and sharing the same layer with the electrode terminals on both sides of a group of the electrode terminals corresponding to each one of the flexible wiring boards in a direction along the peripheral portion of the panel, and providing a first circuit wiring for connecting the second junction terminal corresponding to one of the flexible wiring boards to the first junction terminal corresponding to another flexible wiring board adjacent to the flexible wiring board in proximity to a row formed by the various terminals; and

providing, on the flexible wiring boards, an input terminal, output terminals, and a third junction terminal formed of part of the wiring layer and leading to the

drive IC at places corresponding to the first junction terminal, electrode terminals, and second junction terminal of the peripheral portion of the panel, and providing a second circuit wiring for connecting the input terminal to the third junction terminal is provided; and aligning the first junction terminal, electrode terminals, and second junction terminal of the peripheral portion of the panel with the input terminal, output terminals, and third junction terminal of each one of the flexible wiring boards, respectively, with the peripheral portion of the panel and the flexible wiring boards opposed to each other, and electrically connecting the corresponding terminals to each other by means of a specified electrically connecting material.

In the assembling method according to the fourth aspect of the invention, the first junction terminal, electrode terminals, and second junction terminal of the peripheral portion of the panel are connected to the input terminal, output terminals, and third junction terminal of the flexible wiring board by means of a specified electrical connecting material (anisotropic conductive material, solder, photo-setting insulating resin, etc.). Thus, the corresponding terminals can be collectively connected to each other. Further, there is involved no connecting process of the flexible wiring board and the common wiring board (the control board is connected to the first circuit wiring of the peripheral portion of the panel by means of a connector as in the prior art). Accordingly, the man-hour required is reduced so that the cost lowers. Further, the input terminal and the output terminals are connected under the same conditions. Thus, variation in the connecting conditions of the two types of terminals in fabrication is reduced, so that a stabler reliability of the module can be attained.

The assembly structure according to a fifth aspect of the invention is an assembly structure of a flat type device, in which a panel has a plurality of electrode terminals disposed along a peripheral portion of one surface thereof, a plurality of flexible wiring boards which have a wiring layer on a base material surface with a flexibility and on which a drive IC for driving the panel is mounted are electrically connected to the electrode terminals of the panel, and a control board for feeding a signal for driving the panel is electrically connected to the flexible wiring boards, the assembly structure comprising:

an arrangement of the peripheral portion of the panel where a first junction terminal and a second junction terminal corresponding to each one of the flexible wiring boards and sharing the same layer with the electrode terminals are provided on both sides of a group of the electrode terminals corresponding to each one of the flexible wiring boards in a direction along the peripheral portion of the panel, and where a first circuit wiring for connecting the second junction terminal corresponding to one of the flexible wiring boards to the first junction terminal corresponding to another flexible wiring board adjacent to the flexible wiring board is provided in proximity to a row formed by the various terminals;

an arrangement on the flexible wiring boards where an input terminal, output terminals, and a third junction terminal formed of part of the wiring layer and leading to the drive IC are provided at places corresponding to the first junction terminal, electrode terminals, and second junction terminal of the peripheral portion of the panel, where a second circuit wiring for connecting the input terminal to the third junction terminal is provided, and where a fourth junction terminal leading

to the third junction terminal via a third circuit wiring is provided; and

an arrangement on one surface of the control board where a signal feed terminal for feeding a signal for driving the panel is provided in correspondence to the fourth junction terminal of the flexible wiring boards;

wherein the flexible wiring boards are overlaid on the peripheral portion of the panel so that the first junction terminal, electrode terminals, and second junction terminal of the peripheral portion of the panel are electrically connected to the input terminal, output terminals, and third junction terminal of each one of the flexible wiring boards in their respective correspondence;

and wherein the control board is overlaid on the flexible wiring boards so that the fourth junction terminal of the flexible wiring boards is electrically connected to the signal feed terminal of the control board in correspondence.

In the assembly structure of the flat type device according to the fifth aspect of the invention, in operation, a signal is fed from the signal feed terminal of the control board to the fourth junction terminal of the flexible wiring board. This signal is inputted from the fourth junction terminal to the drive IC sequentially via the third circuit wiring, the third junction terminal, the second circuit wiring, and the input terminal. A signal outputted by the drive IC is fed to the inside of the panel via the output terminals of the flexible wiring board and the electrode terminals of the peripheral portion of the panel (direct route). Thus, the panel is driven. Also, the signal can be fed to the panel through a following indirect route. That is the signal branched by the third junction terminal of the flexible wiring board, passed sequentially through the second junction terminal and first circuit wiring leading thereto of the peripheral portion of the panel, and thus fed to the first junction terminal corresponding to another flexible wiring board adjacent to the flexible wiring board. Then the signal is inputted to the drive IC from the first junction terminal via the input terminal of the adjacent flexible wiring board. A signal outputted by the drive IC is fed to the inside of the panel via the output terminals of the adjacent flexible wiring board and the electrode terminals of the peripheral portion of the panel. In this way, the signal is fed to the electrode terminals corresponding to an adjacent flexible wiring board one after another.

In the assembly structure of the flat type device according to the fifth aspect of the invention, the common wiring board and the connector, which would be disposed sideward of the panel in the prior art, are omitted. Accordingly, the module size is reduced compared with the prior art. Also, the number of parts is reduced, so that the module is reduced in weight. Further, such a reduction in the number of parts allows a reduction in the material cost. Yet, the first junction terminal, electrode terminals, and second junction terminal of the peripheral portion of the panel are collectively connected to the input terminal, output terminals, third junction terminal of the flexible wiring board by means of, for example, an anisotropic conductive material. The connecting process between the flexible wiring boards and the control board is reduced in burden to a level similar to or less than the connecting process for the common wiring board in the prior art. The connecting process for the connector is entirely obviated. Accordingly, the total man-hour required is reduced compared with the prior art. As a result, the cost lowers. Furthermore, the module reliability becomes stabler and improved by virtue of its number of times of connection smaller than in the prior art, and other advantages.

When the panel is generally rectangular shaped and the control board is generally L-, U-, or square-shaped along the peripheral portion of the panel, then the signal is fed from the control board to the flexible wiring boards by a direct route, i.e. a shortest route as required. Accordingly, the wire resistance is reduced.

When the fourth junction terminal of part of the plurality of flexible wiring boards are not connected to the signal feed terminal of the control board, the number of connecting points between the flexible wiring boards and control board is reduced. As a result, the man-hour required is further reduced so that the cost lowers. For example, the fourth junction terminal of the flexible wiring board is connected to the signal feed terminal of the control board at a corner portion of the peripheral portion of the panel, while the fourth junction terminal of the flexible wiring boards is not connected to the signal feed terminal of the control board at places other than the corner portion. In such a case, the signal is fed to the electrode terminals corresponding to the flexible wiring board at the corner portion of the peripheral portion of the panel through the aforementioned direct route, while the signal is fed to the electrode terminals corresponding to flexible wiring boards at places other than the corner portion through the aforementioned indirect route. Yet, in this case, the control board is not required to be provided lengthily along the peripheral portion of the panel, but may be provided only at the corner portion. Accordingly, the module is further reduced in size and weight.

When the fourth junction terminal of the part of the flexible wiring boards has been cut off and removed together with the base material surface, it is no longer necessary to prepare different types of flexible wiring boards previously for assembling. In other words, the flexible wiring boards are prepared as provided with a fourth junction terminal, and the fourth junction terminal is cut off and removed before starting the assembly. In such a case, design cost for the flexible wiring boards will never increase.

When the portion of the part of the flexible wiring boards that projects sideward of the peripheral portion of the panel is bent at least once, the module size is further reduced.

When the control board is overlaid on the peripheral portion of the panel directly or via a spacer and assembled integrally therewith, the module is increased in strength with its reliability enhanced. Also, it is no longer needed to provide any auxiliary reinforcement member for assembling the panel and the control board, so that the module can be designed for small size and light weight.

When the control board is mounted on one surface of the peripheral portion of the panel opposite to the surface on which the electrode terminals are provided, and when the flexible wiring boards are wound around a peripheral portion of the panel and the control board, then the module size is further reduced.

When a clip made of a shape memorizing member having a U shape in section is provided to pinch the peripheral portion of the panel and the control board on outside of the flexible wiring boards so that a group of the electrode terminals corresponding to each one of the flexible wiring boards are press fitted, the terminals can be easily connected to each other. Moreover, any flexible wiring board on which a defective IC that has proved or occurred as such after assembling is mounted can be easily exchanged for new one.

When connection between the peripheral portion of the panel and the flexible wiring boards and connection between the flexible wiring boards and the control board are achieved by an identical connecting material, they can be collectively connected simultaneously by heating and thermally curing

the conductive material by, for example, two thermal press head tips. As a result, the man-hour required is reduced so that the cost lowers.

The assembling method according to a sixth aspect of the invention is a method for assembling a flat type device, in which a panel has a plurality of electrode terminals disposed along a peripheral portion of one surface thereof, a plurality of flexible wiring boards which have a wiring layer on a base material surface with a flexibility and on which a drive IC for driving the panel is mounted are electrically connected to the electrode terminals of the panel, and a control board for feeding a signal fed from external is electrically connected to each of the flexible wiring boards, the method for assembling a flat type device comprising the steps of:

providing, on the peripheral portion of the panel, a first junction terminal and a second junction terminal corresponding to each one of the flexible wiring boards and sharing the same layer with the electrode terminals on both sides of a group of the electrode terminals corresponding to each one of the flexible wiring boards in a direction along the peripheral portion of the panel, and providing a first circuit wiring for connecting the second junction terminal corresponding to one of the flexible wiring boards to the first junction terminal corresponding to another flexible wiring board adjacent to the flexible wiring board in proximity to a row formed by the various terminals;

providing, on the flexible wiring boards, an input terminal, output terminals, and a third junction terminal formed of part of the wiring layer and leading to the drive IC at places corresponding to the first junction terminal, electrode terminals, and second junction terminal of the peripheral portion of the panel; providing a second circuit wiring for connecting the input terminal to the third junction terminal; and providing a fourth junction terminal leading to the third junction terminal via a third circuit wiring;

providing, on one surface of the control board, a signal feed terminal for feeding a signal for driving the panel in correspondence to the fourth junction terminal of the flexible wiring boards;

overlaying the flexible wiring boards on the peripheral portion of the panel so that the first junction terminal, electrode terminals, and second junction terminal of the peripheral portion of the panel are electrically connected to the input terminal, output terminals, and third junction terminal of each one of the flexible wiring boards in their respective correspondence; and

overlaying the control board on the flexible wiring boards so that the fourth junction terminal of the flexible wiring boards is electrically connected to the signal feed terminal of the control board in correspondence.

In the method for assembling the flat type device according to the sixth aspect of the invention, the first junction terminal, electrode terminals, second junction terminal of the panel are collectively connected to the input terminal, output terminals, and third junction terminal of the flexible wiring board by means of, for example, an anisotropic conductive material. Also, the connecting process between the flexible wiring boards and the control board is reduced in burden to a level similar to or less than the connecting process for the common wiring board in the prior art. The connecting process for the connector is entirely obviated. Accordingly, the total man-hour required is reduced compared with the prior art. As a result, the cost lowers.

When the control board is overlaid directly or via a spacer on one surface of the peripheral portion of the panel opposite

to the surface on which the electrode terminals are provided, and when the flexible wiring boards are wound around a peripheral portion of the panel and the control board, and further when a clip made of a shape memorizing member having a U shape in section is provided to pinch the peripheral portion of the panel and the control board on outside of the flexible wiring boards so that a group of the terminals corresponding to each one of the flexible wiring boards are press fitted, then the module size is further reduced. Yet, the terminals can be easily connected to each other so that the assembly work is facilitated.

When a connecting material which will be cured by heating and pressurization or by heating, cooling, and pressurization is provided between the peripheral portion of the panel and the flexible wiring boards and between the flexible wiring boards and the control board; and when connection of the terminals in their correspondence is simultaneously achieved by two thermal press head tips, then connection between the panel and the flexible wiring boards and connection between the flexible wiring boards and the control board can be achieved simultaneously and collectively. Accordingly, the man-hour required is reduced so that the cost lowers.

The assembly structure according to a seventh aspect of the invention is an assembly structure of a flat type device having:

a display panel having a peripheral portion; and a plurality of wiring boards which are disposed on the peripheral portion of the display panel in an array direction along the peripheral portion and on which a circuit element for driving the display panel is mounted,

the plurality of wiring boards respectively comprising an insulating substrate; a plurality of connecting terminals arrayed on the insulating substrate in such a direction as to intersect the array direction of the wiring boards at proximately both ends of each one of the wiring boards in their array direction; and a bypass wiring which electrically connects at least part of the plurality of connecting terminals at proximately the both ends with each other and which is electrically connected to the circuit element;

the display panel including a plurality of common lines which are connected respectively to the connecting terminals of each one of the plurality of wiring boards adjacent to one another on the peripheral portion and which are formed between one another of the connecting terminals of the plurality of wiring boards adjacent to one another;

wherein the connecting terminals of each one of the plurality of wiring boards are connected to the plurality of common lines and other connecting terminals on the display panel by means of an identical connecting material.

According to the seventh aspect of the invention, the display device comprises: a display panel having a peripheral portion; and a plurality of wiring boards which are disposed on a peripheral portion of the display panel in an array direction extending along the peripheral portion and on which a circuit element for driving the display panel is mounted. A plurality of connecting terminals arranged on the plurality of wiring boards are arrayed on an insulating substrate at proximately both ends in the array direction of the wiring boards in such a direction as to intersect this array direction. Also, a bypass wiring is provided on each of the plurality of wiring boards. The bypass wiring electrically connects at least part of the plurality of connecting terminals at the proximately both ends of the flexible wiring boards

13

with each other and is electrically connected to the circuit element.

Such a structure of the wiring boards makes the wire resistance due to distribution of the common lines lower than when the connecting terminals are arrayed in parallel in the array direction, leading to a stabler display grade.

The assembly structure according to an eighth aspect of the invention is an assembly structure of a flat type device having:

a display panel having a peripheral portion; and a plurality of wiring boards which are disposed on the peripheral portion of the display panel in an array direction along the peripheral portion and on which a circuit element for driving the display panel is mounted,

the plurality of wiring boards respectively comprising an insulating substrate; a plurality of connecting terminals arrayed on the insulating substrate in such a direction as to intersect the array direction of the wiring boards at proximately both ends of each one of the wiring boards in their array direction; and a bypass wiring which electrically connects at least part of a plurality of connecting terminals at proximately the both ends with each other and which is electrically connected to the circuit element;

the display panel including a plurality of common lines which are connected in common to part of the connecting terminals of each one of the plurality of wiring boards on the peripheral portion and which are formed over a range including an array range of the plurality of wiring boards;

wherein the connecting terminals of each one of the plurality of wiring boards are connected to the plurality of common lines and other connecting terminals on the display panel by means of an identical connecting material.

According to the eighth aspect of the invention, the display panel has a plurality of common lines which are connected to their corresponding connecting terminals of a plurality of wiring boards adjacent to one another on the peripheral portion and which are formed between one and another of the connecting terminals of the plurality of wiring boards adjacent to one another. The connecting terminals of the plurality of wiring boards are connected to the plurality of common lines and other connecting terminals on the display panel by means of the same connecting material.

Such a structure of the display panel makes it feasible to substantially reduce the area occupied by the display device. The reason is that, compared with the case where a separate wiring board other than the display panel and the above wiring boards is used so that the above common lines are provided on the separate wiring board, such a separate wiring board can be omitted.

In this way, according to the seventh and eighth aspects of the invention, the following advantages can be attained:

- (1) The display device is offered with smaller size and less thickness;
- (2) The display device is offered with less weight; and
- (3) The display device is less affected by any external force by virtue of its small-size structure, with its reliability as a display device improved.

The assembly structure according to a ninth aspect of the invention is an assembly structure of a flat type device having:

a display panel having a peripheral portion; and a plurality of wiring boards which are disposed on the peripheral

14

portion of the display panel in an array direction along the peripheral portion and on which a circuit element for driving the display panel is mounted,

the plurality of wiring boards respectively comprising an insulating substrate; and a bypass wiring which electrically connects at least part of a plurality of connecting terminals at proximately both ends of the wiring boards with each other and which is electrically connected to the circuit element;

the display panel including a plurality of first common lines which are connected in common to the connecting terminals of each one of the plurality of wiring boards on the peripheral portion and which are formed over a range including an array range of the plurality of wiring boards; and a plurality of second common lines which are connected in common to part of the connecting terminals of each one of the plurality of wiring boards on the peripheral portion and which are formed over a range including the array range of the plurality of wiring boards;

wherein the connecting terminals of each one of the plurality of wiring boards are connected to the first common lines, the second common lines, and other connecting terminals on the display panel by means of an identical conductive connecting material.

According to the ninth aspect of the invention, the assembly structure of the display device comprises a display panel having a peripheral portion, and a plurality of wiring boards. The plurality of wiring boards are arranged on a peripheral portion of the display panel in an array direction along the peripheral portion and each have a circuit element mounted thereon for driving the display panel. A plurality of wiring boards each have a bypass wiring which electrically connects at least part of the plurality of connecting terminals at proximately both ends of the wiring boards with each other, and which is electrically connected to the circuit element.

The second common lines formed on the display panel are connected in common to part of the connecting terminals of each one of the plurality of wiring boards on the peripheral portion of the display panel. Also, the first common lines are formed over a range including the array range of the plurality of wiring boards on the display panel. The connecting terminals of each of the plurality of wiring boards are connected to the first and second common lines and other connecting terminals on the display panel by means of the same connecting material.

Also in the ninth aspect of the invention as described above, the same advantages as listed in the foregoing articles (1) to (3) can be attained.

In the seventh aspect of the invention, the bypass wiring may include a first bypass wiring which is formed on the insulating substrate and which directly connects the connecting terminals at proximately the both ends to one another.

Also, the bypass wiring may include: a second bypass wiring formed on the insulating substrate over a range from proximately any one of the both ends to the circuit element; a third bypass wiring which is formed on the insulating substrate over a range from proximately the other any one of the both ends to the circuit element; and an in-element bypass wiring which is formed within the circuit element and both ends of which are connected to the second bypass wiring and the third bypass wiring, respectively.

In the seventh aspect of the invention, the bypass wiring may be provided on both surfaces of the insulating substrate of each one of the wiring boards.

Also, the first bypass wiring may be provided on the insulating substrate and at such a position that the first

bypass wiring passes between the insulating substrate and the circuit element.

Also, the connecting material may be an anisotropic conductive film.

Further, the display panel may comprise a pair of display boards having display-use electrodes provided on their surfaces opposite to each other and having an optical transmission property, wherein the common lines are provided both on at least one of the pair of display boards within a range of overlap portion of these boards excepting a area of the display-use electrodes and on the peripheral portion.

The above seventh, eighth, and ninth aspects of the invention offer the following advantages:

- (1) Since the circuit board on which the common lines for input signals to the ICs are formed is no longer necessitated, it becomes possible to reduce material cost and make the display panel thinner, more lightweight, and more compact. Also, a reduced number of connection processes leads to a lower rate of occurrence of defectives and an improved yield of the assembling process.
- (2) Since the input/output-use electrode terminals of the flexible wiring board are collectively connected to the electrode terminals of the display panel, the man-hour required for assembling can be reduced to a substantial extent so that the cost can be reduced.
- (3) Since the common lines for use of input signals or power supply are formed between one wiring board and its adjacent wiring board in the peripheral portion of the panel so that an input signal is bypassed within the wiring boards, the wire resistance between wiring boards connected to both ends of the peripheral portion of the display panel is reduced. Further, an increased connection width of the wiring boards and the electrode terminals of the display panel results in a decreased connection resistance.
- (4) With part of the common lines for input signals formed outside opposite electrodes, the delay time of a signal is reduced. By virtue of the above advantages, there can be provided a liquid crystal display device which is prevented from failures in displaying an image, good in display grade, and compact in construction.

The method for assembling a flat type display device according to a tenth aspect of the invention including a display panel having a peripheral portion, comprising the steps of:

aligning a plurality of wiring boards on which a circuit element for driving the display panel is mounted with the peripheral portion of the display panel; and

connecting the display panel to the wiring boards by means of a connecting material in such a way that signal input terminals, a bypass signal input terminal, and signal output terminals for the display panel of the wiring boards are treated collectively.

The assembling method of a display device according to the tenth aspect of the invention is implemented in the following way. A plurality of wiring boards each having a circuit element for driving the display panel mounted thereon are aligned with the common lines of the peripheral portion of the display panel. Connecting terminals of the plurality of wiring boards are connected to the common lines and other connecting terminals of the peripheral portion of the display panel by means of a connecting material. If the common lines were provided to the display panel or a separate wiring board other than the plurality of wiring boards, there would be involved connection processes between the plurality of wiring boards and the display panel

and between the plurality of wiring boards and the separate wiring board. In the present assembling method, the need for the connecting process between the plurality of wiring boards and the separate wiring board is eliminated. Thus, the number of assembling processes for the display device is reduced substantially, so that the assembling process of the display device is simplified.

According to the assembling method of the tenth aspect of the invention, as the connection of terminals is currently implemented with an anisotropic conductive material as a mainstream, use of an anisotropic material as the connecting material eliminates the need of developing new connecting materials and the existing know-hows can be utilized. Thus, the conventional manufacturing equipment may more often be employed as they are, resulting in less investment in plant and equipment.

BRIEF DESCRIPTION OF THE DRAWINGS

The present invention will become more fully understood from the detailed description given hereinbelow and the accompanying drawings which are given by way of illustration only, and thus are not limitative of the present invention, and wherein:

FIG. 1 is a perspective view of a liquid crystal module which is an embodiment of the present invention according to its first, second, and fourth aspects;

FIG. 2 is a plan view of the peripheral portion of the module shown in FIG. 1;

FIG. 3 is a sectional view taken along the line B—B' of FIG. 2;

FIGS. 4(a) and 4(b) are views showing a modification example of the liquid crystal module;

FIGS. 5(a) and 5(b) are views showing another modification example of the liquid crystal module;

FIGS. 6(a), 6(b) and 6(c) are views showing further modification example of the liquid crystal module;

FIG. 7 is a perspective view of a liquid crystal module which is an embodiment of the present invention according to its third and fourth aspects;

FIGS. 8(a) and 8(b) are plan views of the peripheral portion of the liquid crystal module;

FIG. 9 is a sectional view of the peripheral portion of the liquid crystal module;

FIG. 10 is a perspective view showing a modification example of the liquid crystal module;

FIG. 11 is a sectional view of the modification example of FIG. 10;

FIG. 12 is a plan view showing a flexible wiring board in which a slit is provided;

FIG. 13 is a sectional view of the flexible wiring board in which a slit is provided;

FIG. 14 is a sectional view of a flexible wiring board in which an opening is provided;

FIG. 15 is a sectional view of a flexible wiring board bent 90 degrees;

FIG. 16 is a sectional view of a flexible wiring board bent 180 degrees;

FIG. 17 is a perspective view of a liquid crystal module which is an embodiment of the present invention;

FIGS. 18(a) and 18(b) are plan views of the peripheral portion of the liquid crystal module;

FIG. 19 is a perspective view showing an modification example of the liquid crystal module of FIG. 17;

17

FIG. 20 is a perspective view showing a modification example of the liquid crystal module of FIG. 17;

FIG. 21 is a perspective view showing a modification example of the liquid crystal module of FIG. 17;

FIG. 22 is a main-part sectional view of the liquid crystal module of FIG. 17;

FIG. 23 is a sectional view showing a modification example of the liquid crystal module of FIG. 17;

FIG. 23 is a sectional view showing a modification example of the liquid crystal module of FIG. 17;

FIG. 25 is a sectional view showing a modification example of the liquid crystal module of FIG. 17;

FIG. 26 is a sectional view showing a modification example of the liquid crystal module of FIG. 17;

FIG. 27 is a sectional view showing a modification example of the liquid crystal module of FIG. 17;

FIG. 28 is a sectional view showing an assembled state of the liquid crystal module of FIG. 24;

FIG. 29 is a sectional view showing an assembled state of the liquid crystal module of FIG. 24;

FIG. 30 is a perspective view showing a liquid crystal display device which is an embodiment of the present invention according to its seventh, eighth, and tenth aspects;

FIG. 31 is a plan view of the vicinity of a flexible wiring board of the liquid crystal display device of FIG. 30;

FIG. 32 is an exploded perspective view of the vicinity of a flexible wiring board of the liquid crystal display device of FIG. 30;

FIG. 33 is a sectional view taken along the line X33—X33 of FIG. 31;

FIG. 34 is a sectional view taken along the line X34—X34 of FIG. 31;

FIG. 35 is a flow chart showing an example of the manufacturing process of a display device according to the tenth aspect of the present invention;

FIG. 36 is a sectional view showing the manufacturing process;

FIG. 37 is a plan view of a modification example of the flexible wiring board to be used in the liquid crystal display device of FIG. 30;

FIG. 38 is a perspective view showing a liquid crystal display device which is a second embodiment of the panel according to its seventh aspect;

FIG. 39 is a sectional view of the embodiment of FIG. 38;

FIG. 40 is a plan view showing a liquid crystal display device which is a third embodiment of the present invention according to its seventh aspect;

FIG. 41 is a sectional view taken along the line X41—X41 of FIG. 40;

FIG. 42 is a sectional view taken along the line X42—X42 of FIG. 40;

FIG. 43 is a plan view of a liquid crystal display device in which is a fourth embodiment of the present invention according to its seventh aspect;

FIG. 44 is a sectional view taken along the line X44—X44 of FIG. 43;

FIG. 45 is a sectional view showing a first modification example of the above embodiment;

FIG. 46 is a sectional view showing a second modification example of the above embodiment;

FIG. 47 is a plan view showing a liquid crystal display device which is a fifth embodiment of the present invention according to its seventh aspect;

18

FIG. 48 is a sectional view taken along the line X48—X48 of FIG. 47;

FIG. 49 is a plan view showing a liquid crystal display device which is a sixth embodiment of the present invention according to its seventh aspect;

FIG. 50 is a sectional view taken along the line X50—X50 of FIG. 49;

FIG. 51 is a sectional view showing a liquid crystal display device which is a seventh embodiment of the present invention according to its seventh aspect;

FIG. 52 is a plan view of the liquid crystal display device of FIG. 51;

FIG. 53 is a sectional view showing a liquid crystal display device which is an eighth embodiment of the present invention according to its seventh aspect;

FIG. 54 is a plan view of the liquid crystal display device of FIG. 53;

FIG. 55 is a perspective view of a prior-art liquid crystal module; and

FIG. 56 is a sectional view taken along the line A—A of FIG. 55.

DETAILED DESCRIPTION OF THE PREFERRED EMBODIMENTS

The assembly structure of a display panel according to the present invention is now described in more detail by way of its preferred embodiments.

FIG. 1 is a perspective view of the liquid crystal module which is an embodiment of the first, second, and fourth aspect of the present invention. A liquid crystal panel 20 has liquid crystals 21 (see FIG. 4(b)) sealed between a pair of glass substrates 1, 2. Flexible wiring boards 4, 4', . . . each having a drive IC 5 for driving the liquid crystal panel 20 mounted thereon are attached on the peripheral portion of one glass substrate 2.

FIG. 2 is a plan view of the peripheral portion of the liquid crystal panel 20 of FIG. 1, while FIG. 3 is a sectional view taken along the line B—B' of FIG. 2 in the arrow direction. As shown in FIG. 2, on the peripheral portion of the liquid crystal panel 20 (glass substrate 2), there are disposed a plurality of electrode terminals 3 which lead to pixels (not shown) inside the panel. As shown in FIG. 3, a bus line 73 as a circuit wiring is provided at a layer below the electrode terminals 3. The bus line 73 extends along the peripheral portion of the panel and is electrically insulated from the electrode terminals 3 with an insulating layer 9 interposed therebetween (a base coat 11 having insulating property is provided between the bus line 73 and the glass substrate 2). The bus line 73 has through holes 74 formed at specified points thereon. A junction terminal 45 is also provided so as to lead to the bus line 73 via the through holes 74. The junction terminal 45 shares the same layer with the electrode terminals 3 do. On the other hand, as shown in FIG. 2, the flexible wiring board 4 is rectangular in shape, having an input terminal 44 and output terminals 42 of a strip shape provided along one side line of the rectangle on one surface of the flexible wiring board 4. These input terminal 44 and output terminals 42 lead to the drive IC 5 by means of lines 43, 41. The drive IC 5 is mounted along a side line opposite to that for the input terminal 44 and the output terminals 42 by means of gang bond (collective thermal press bonding) or use of solder or conductive paste. It is noted that the line 43 has a capacitor 55 for use of signal adjustment connected thereto. Adjacent to the flexible wiring board 4 is provided

a flexible wiring board 4' having the completely same arrangement as in the board 4.

In the assembling, while the peripheral portion of the liquid crystal panel 20 and the flexible wiring board 4 are opposed to each other, the junction terminal 45 and the electrode terminals 3 are aligned with the input terminal 44 and the output terminals 42, respectively, in one-to-one correspondence. Then, as shown in FIG. 3, the junction terminal 45 and the electrode terminals 3 are pressed or thermally press bonded with the input terminal 44 and the output terminals 42 by means of an anisotropic conductive material 95. Thereby, the junction terminal 45 and the electrode terminals 3 are collectively electrically connected to the input terminal 44 and the output terminals 42, respectively. Also, as shown in FIG. 1, a connector 8 for feeding drive-use signals from external is connected to a portion of the bus line 73 corresponding to a corner of the liquid crystal panel 20. Further, connection of the input terminal 44 and that of the output terminals 42 may be achieved by the anisotropic conductive material 95 or instead by other materials such as solder or photo-setting resins.

In operation, a drive-use signal is fed to the bus line 73 of the peripheral portion of the panel via the connector 8 from external. This signal is inputted to the drive IC 5 sequentially through the junction terminal 45, the input terminal 44 of the flexible wiring board 4, and the line 43 as shown in FIG. 2. A signal outputted by the drive IC 5 is fed to pixels (not shown) of the liquid crystal panel 20 sequentially through the line 41, the output terminals 42, and the electrode terminals 3 of the peripheral portion of the panel. Thus, the liquid crystal panel 20 is driven.

Since this liquid crystal module is provided with no common wiring board 307 that would be disposed on one side of the glass substrate 2 in the prior art (see FIG. 55), the size of the module can be reduced compared with the prior art. Also, the number of parts can be reduced so that the weight of the module can also be reduced. Such reduction in the number of parts allows a reduction in material cost. Yet, connection of the terminals 45, 3 of the peripheral portion of the panel and the terminals 44, 42 of the flexible wiring board can be accomplished only by a one-time connecting process. As a result, the man-hour required can be reduced compared with the prior art, leading to a cost reduction.

FIG. 4 shows a modification example of the above liquid crystal module. In this example, as shown in FIG. 4(a), after the connecting process, the portion of the flexible wiring boards 4, 4', . . . that projects sideward of the peripheral portion of the liquid crystal panel (glass substrate 2) is bent so as to be wound around the peripheral portion of the panel. Further, as shown in FIG. 4(b), a clip 10 made of a shape memorizing alloy (or shape memory plastics) and having a U shape in section is used to pinch the peripheral portion of the panel on the outside of the flexible wiring board 4 so that the board 4 is press fitted thereto. This facilitates the connection of the terminals 45, 3 of the peripheral portion of the panel to the terminals 44, 42 of the flexible wiring board 4 in their correspondence, as well as the replacement of defective ICs.

Otherwise, as shown in FIGS. 5(a), (b) and FIGS. 6(a), (b), portions where the peripheral portion of the liquid crystal panel 20 overlaps with the flexible wiring boards 4, 4', . . . as well as the drive IC 5 may be firmly coated with an epoxic, ultraviolet-setting type protective resin 6 with high rigidity, which would tend to crack in the conventional structure so that it could not be used. Also, of course, a silicone series, soft resin may be used to coat the portions as

in the prior art. It is noted that FIGS. 5(a), (b) show an example in which the protective resin 6 is applied to the module of FIG. 1, while FIGS. 6(a), (b) show an example in which the protective resin 6 is applied to the module where the flexible wiring board is bent by its portion projecting out of the peripheral portion of the panel. The protective resin 6 serves to prevent any harmful substances such as moisture, NaCl, and H₂O gas from penetrating the connecting portions between the terminals 45 and 44, or 3 and 42. As a result, the liquid crystal module can be improved in its reliability. Furthermore, as shown in FIG. 6(c), the flexible wiring board 4 may be bent and folded in two on the peripheral portion of the liquid crystal panel 20, and then coated as a whole with the protective resin 6.

FIG. 7 is a perspective view of a liquid crystal module which is an embodiment of the present invention according to its third and fourth aspects. A liquid crystal panel 120 has liquid crystals 121 (see FIG. 9) sealed between a pair of glass substrates 101, 102. Flexible wiring boards 104, 104', 104'', 104S, and 104S' each having a drive IC 105 for driving the liquid crystal panel 120 mounted thereon are attached on the peripheral portion of one glass substrate 102.

FIGS. 8(a) and (b) are plan views of the peripheral portion of the liquid crystal panel 120 and the flexible wiring board 104, respectively. As shown in FIG. 8(a), on the peripheral portion of the liquid crystal panel 120 (glass substrate 102), there are disposed a first junction terminal 145, electrode terminals 103, and a second junction terminal 146 at a specified pitch in a plurality in series, all of which terminals are strip shaped and share the same layer. The electrode terminals 103 lead to pixels (not shown) inside the panel via lines 131. A first circuit wiring 173 is provided on the panel's inner side of the junction terminals 146, 145. The first circuit wiring 173 extends along the peripheral portion of the panel, electrically connecting the junction terminal 146 and the junction terminal 145 to each other. In addition, the lines 131 and the first circuit wiring 173 are coated with an insulating layer 109. On the other hand, as shown in FIG. 8(b), the flexible wiring board 104 is of an approximately rectangular shape, having a wiring layer including an input terminal 144, output terminals 142, a third junction terminal 148 provided to a base material surface 140 with a flexibility. The input terminal 144, the output terminals 142, and the third junction terminal 148 are all strip-shaped and provided at places corresponding to the terminals 145, 103, and 146, respectively, of the peripheral portion of the panel on the rear side of the flexible wiring board 104. On one side of the flexible wiring board 104, a second circuit wiring 147 for connecting the input terminal 144 to the third junction terminal 148 is provided so as to extend along the row of the input terminal 144, output terminals 142, and a third junction terminal 148. The input terminal 144 and the output terminals 142 lead to the drive IC 105 via a line 143 and a line 141, respectively. The drive IC 105 is mounted on the flexible wiring board 104 in such a way that it extends in its longitudinal direction along the row of the input terminal 144, the output terminals 142, and the third junction terminal 148. Also, as shown in FIG. 9, the drive IC 105 is connected to the line 141 and the line 143 via a bump electrode 105a and a bump electrode 105b, respectively, and coated at its periphery with a resin 196. It is noted that, as shown in FIG. 8(b), a capacitor 155 for use of signal adjustment is connected to the line 143 so as to prevent any differences in display grade among the drive ICs 105, 105, . . .

Also, it is preferable that an insulating resin or the like (not shown) is applied to the surface of the second circuit wiring 147 to enhance the insulating reliability among lines.

In the assembling, while the peripheral portion of the liquid crystal panel 120 and the flexible wiring board 104 are opposed to each other, the first junction terminal 145, the electrode terminals 103, and the second junction terminal 146 are aligned with the input terminal 144, the output terminals 142, and the third junction terminal 148, respectively, in one-to-one correspondence. Then, as shown in FIG. 9, the first junction terminal 145, the electrode terminals 103, and the second junction terminal 146 are thermally press bonded with the input terminal 144, the output terminals 142, and the third junction terminal 148 by means of an anisotropic conductive material 195. Thereby, the various terminals are collectively electrically connected to their corresponding ones. The flexible wiring board 104, as shown in the figure, is overlapped with the peripheral portion of the panel in such a way that the row of the input terminal 144, the output terminals 142, and the third junction terminal 148 is located outside the second circuit wiring 147. It is noted that the anisotropic conductive material 195 may be provided in such an extent as to cover the dimensions of the various terminals, or otherwise may be provided over the outer whole range of the insulating layer 109. Also, solder, photo-setting resins, or other connecting materials may be used instead of the anisotropic conductive material 195. In this way, as shown in FIG. 7, flexible wiring boards 104', 104'' with the same pattern as that of the flexible wiring board 104 are connected along one side of the liquid crystal panel 120, while flexible wiring boards 104S, 104S' with a different pattern from that of the flexible wiring board 104 are connected along another side. Further, like the prior art, at a portion of the first circuit wiring 173 corresponding to a corner of the liquid crystal panel 120, a control board (not shown) for feeding signals for driving the liquid crystal panel 120 is connected via a connector 108.

In operation, a drive-use signal is fed to the first circuit wiring 173 of the peripheral portion of the panel via the connector 108 from the control board. This signal is inputted to the drive IC 105 sequentially through the first junction terminal 145, the input terminal 144 of the flexible wiring board 104, and the line 143 as shown in FIG. 8. A signal outputted by the drive IC 105 is fed to pixels (not shown) of the liquid crystal panel 120 sequentially through the line 141 and output terminals 142 of the flexible wiring board 104, the electrode terminals 103 of the peripheral portion of the panel, and the lines 131. Thus, the liquid crystal panel 120 is driven. Also, the signal is branched at the first junction terminal 145 so as to be fed to the first junction terminal 145 of another flexible wiring board 104' adjacent to the flexible wiring board 104, sequentially through the second circuit wiring 147 and third junction terminal 148 of the flexible wiring board 104, the second junction terminal 146 of the peripheral portion of the panel, and the first circuit wiring 173 leading thereto. Then the signal is inputted from the first junction terminal 145 via the input terminal of the flexible wiring board 104' to the drive IC 105. A signal outputted by this drive IC 105 is fed to the inside of the panel via the output terminals of the flexible wiring board 104' and the electrode terminals 103 of the peripheral portion of the panel. In this way, the signal is fed to the electrode terminals 103 of the flexible wiring boards 104, 104', . . . adjacent to one another, in turn. The signal is similarly fed to the electrode terminals 103 of the flexible wiring boards 104S, 104S' adjacent to one another on another side of the liquid crystal panel 120 (FIG. 7).

Since this liquid crystal module is provided with no common wiring board 307 that would be disposed sideward of the panel in the prior art (see FIGS. 55 and 56), the size

of the module can be reduced compared with the prior art. Also, the number of parts can be reduced so that the weight of the module can also be reduced. Such reduction in the number of parts allows a reduction in material cost. Yet, the first junction terminal 145, electrode terminals 103, and second junction terminal 146 of the peripheral portion of the panel are connected to the input terminal 144, output terminals 142, third junction terminal 148 of the flexible wiring board 104 collectively by means of the anisotropic conductive material 195. Further, the connection process of the flexible wiring boards 104, . . . to the common wiring board is not involved (the control board is connected to the first circuit wiring of the peripheral portion of the panel via a connector as in the prior art). As a result, the man-hour required can be reduced compared with the prior art, leading to a cost reduction. A higher reliability also can be attained.

FIGS. 10 and 11 show a modification example of the above-described liquid crystal module. In this example, as shown in FIG. 11, a slit 96 is provided to a portion of the base material surface 140 where the flexible wiring boards 104, . . . are wound around the peripheral portion of the panel, in the direction along the peripheral portion. Further, the flexible wiring boards 104, . . . are connected to the peripheral portion of the panel and thereafter bent by their portion projecting sideward of the peripheral portion of the liquid crystal panel 120 (glass substrate 102) so as to be wound around the peripheral portion of the panel. Thereby, the size of the module can be further reduced. It is noted that the provision of the slit 96 makes the flexible wiring boards 104, . . . easy to bend, facilitating the assembling. In this assembling state, a clip (not shown) made of a shape memorizing alloy or shape memory plastics having a U shape in section may also be used to pinch the peripheral portion of the panel on the outer peripheral side of the flexible wiring boards 104, . . . so that the various terminals involved are press bonded. As a result, the terminals can be easily connected to their corresponding ones.

Also, as shown in FIGS. 12 and 13, a slit 97 may be provided to a portion of the base material surface 140 corresponding to a gap between the row of the input terminal 144, the output terminals 142, and the third junction terminal 148 of the flexible wiring board 4 and the second circuit wiring 147, so that it ranges along the gap. In this case, since the slit 97 is in proximity to the row of the terminals 144, 142, and 148, any excessive portions of the anisotropic conductive material 195 will easily flow out uniformly among the terminals through the slit 97 when the flexible wiring board 104 is connected to the peripheral portion of the panel, as shown in FIG. 13. As a result, a stabler reliability of the connecting portions is attained.

Further, as shown in FIG. 14, it is also possible that base material surface 140 of the flexible wiring board 104 corresponding to the input terminal 144, output terminals 142, and the third junction terminal 148 are removed and an opening 98 is provided. In this case, with the flexible wiring board 104 connected to the peripheral portion of the liquid crystal panel 120, a prober terminal for performance tests can be thrown in contact with the input terminal 144, output terminals 142, or third junction terminal 148 of the flexible wiring board 104. Therefore, performance tests for the liquid crystal panel 120 and the drive ICs can be easily performed.

Further, as shown in FIG. 15, it is also possible that a portion of the flexible wiring board 104 corresponding to the second circuit wiring 147 is bent 90 degrees to 180 degrees with respect to the portions of the input terminal 144, the output terminals 142, and the third junction terminal 148. In such a case, the width of the peripheral portion of the panel

is required only to be equivalent to the terminals 144, 142, and 148 so that the width of the peripheral portion of the panel can be designed narrow. As a result, the module size can be further reduced.

Further, as shown in FIG. 16, it is also possible that the flexible wiring board 104 is overlaid on the peripheral portion of the panel so that the row of the input terminal 144, the output terminals 142, and the third junction terminal 148 is located inside the second circuit wiring 147, and that a portion of the flexible wiring board 104 opposite to the second circuit wiring 147 is bent 90 degrees to 180 degrees with respect to the portions corresponding to the terminals 144, 142, and 148. It is noted that numeral 109 denotes a rod-like member for giving the bent portion 100 of the flexible wiring board 104 a curvature. In such a case, as in the case of FIG. 15, the width of the peripheral portion of the panel is required only to be equivalent to the terminals 144, 142, and 148, so that the width of the peripheral portion of the panel can be designed narrow. As a result, the module size can be further reduced. Yet, since the drive IC 105 is mounted at the bent portion as shown in the figure, the extent in which the flexible wiring board 104 projects sideward of the peripheral portion of the panel can be reduced by an extent corresponding to the width of the drive IC. As a result, the module size can be further reduced.

In addition, the flexible wiring board may be a front-and-rear double-layer wiring type with bumps. This makes it possible to design other different compact modules.

FIG. 17 is a perspective view of a liquid crystal module which is an embodiment according to the fourth and sixth aspect of the present invention. A liquid crystal panel 120 has liquid crystals 121 (see FIG. 22) sealed between a pair of rectangular glass substrates 101, 102. Five flexible wiring boards 104A, 104A', 104A'', 104T, and 104T' each having a drive IC 105 for driving the liquid crystal panel 120 mounted thereon are attached on the peripheral portion of one glass substrate 102. An L-shaped control board 111 for feeding signals for driving the liquid crystal panel 120 is provided along the peripheral portion of the liquid crystal panel 120 (numeral 191 denotes an electronic component).

FIGS. 18(a) and (b) are plan views of the peripheral portion of the liquid crystal panel 120 and the flexible wiring board 104A, respectively. As shown in FIG. 18(a), on the peripheral portion of the liquid crystal panel 120 (glass substrate 102), there are disposed a first junction terminal 145, electrode terminals 103, and a second junction terminal 146 at a specified pitch in a plurality in series, all of which terminals are strip shaped and share the same layer. The electrode terminals 103 lead to pixels (not shown) inside the panel via lines 131. A first circuit wiring 173 is provided on the panel's inner side of the junction terminals 146, 145. The first circuit wiring 173 extends along the peripheral portion of the panel, electrically connecting the junction terminal 146 and the junction terminal 145 to each other. In addition, the lines 131 and the first circuit wiring 173 are covered with an insulating layer 109. On the other hand, as shown in FIG. 18(b), the flexible wiring board 104A is of an approximately rectangular shape, having a wiring layer including an input terminal 144, output terminals 142, a third junction terminal 148 provided to a base material surface 140 with a flexibility. The input terminal 144, the output terminals 142, and the third junction terminal 148 are all strip-shaped and provided at places corresponding to the terminals 145, 103, and 146, respectively, of the peripheral portion of the panel on the rear side of the flexible wiring board 104A. On one side of the flexible wiring board 104A, a second circuit wiring 147 for connecting the input terminal 144 to the third junction

terminal 148 is provided so as to extend along the row of the input terminal 144, output terminals 142, and a third junction terminal 148. The input terminal 144 and the output terminals 142 lead to the drive IC 105 via a line 143 and a line 141, respectively. The drive IC 105 is mounted on the flexible wiring board 104A in such a way that it extends in its longitudinal direction along the row of the input terminal 144, the output terminals 142, and the third junction terminal 148. Also, as shown in FIG. 22, the drive IC 105 is connected to the line 141 and the line 143 via a bump electrode 105a and a bump electrode 105b, respectively. Also, as shown in FIG. 18(b), a fourth junction terminal 149 is provided to the flexible wiring board 104A. This fourth junction terminal 149 leads to the third junction terminal 148 via the third circuit wiring 150 and is located at a place corresponding to a signal feed terminals 151 provided on one surface of the control board 111 shown in FIG. 18(a). It is noted that a capacitor 155 for use of signal adjustment is connected to the line 143 so as to prevent any differences in display grade among the drive ICs 105, 105, . . .

In the assembling, while the peripheral portion of the liquid crystal panel 120 and the flexible wiring board 104A are opposed to each other, the first junction terminal 145, the electrode terminals 103, and the second junction terminal 146 are aligned with the input terminal 144, the output terminals 142, and the third junction terminal 148, respectively, in one-to-one correspondence. Then, as shown in FIG. 22, the first junction terminal 145, the electrode terminals 103, and the second junction terminal 146 are thermally press bonded with the input terminal 144, the output terminals 142, and the third junction terminal 148 by means of an anisotropic conductive material 195. Thereby, the various terminals are collectively electrically connected to their corresponding ones. The flexible wiring board 104A, as shown in the figure, is overlapped with the peripheral portion of the panel in such a way that the row of the input terminal 144, the output terminals 142, and the third junction terminal 148 is located outside the second circuit wiring 147. It is noted that the anisotropic conductive material 195 may be provided in such an extent as to cover the dimensions of the various terminals, or otherwise may be provided over the outer whole range of the insulating layer 109. Also, solder or other connecting materials may be used instead of the anisotropic conductive material 195. In this way, as shown in FIG. 17, flexible wiring boards 104A', 104A'' with the same pattern as that of the flexible wiring board 104A are connected along one side of the liquid crystal panel 120, while flexible wiring boards 104T, 104T' with a different pattern from that of the flexible wiring board 104A are connected along another side. Further, the fourth junction terminals 149 of the flexible wiring boards 104A, are aligned with the signal feed terminals 151 of the control board 111 each in one-to-one correspondence, and the corresponding terminals are connected to each other by means of the anisotropic conductive material 195 as shown in FIG. 22.

In operation, a signal is fed from the signal feed terminal 151 of the control board 111 to the fourth junction terminal 149 of the flexible wiring board 104A. This signal is inputted to the drive IC 105 from the fourth junction terminal 149 sequentially through the third circuit wiring 150, the third junction terminal 148, the second circuit wiring 147, the input terminal 144, and the line 143, as shown in FIG. 18(b). A signal outputted by the drive IC 105 is fed to pixels (not shown) of the liquid crystal panel 120 sequentially through the line 141 and output terminals 142 of the flexible wiring board 104A, the electrode terminals 103 of the peripheral portion of the panel, and the lines 131 (direct route). Thus,

25

the liquid crystal panel **120** is driven at a shortest route and with less wire resistance. Also, the signal can be fed to the panel in another indirect route as described below. That is, the signal is branched at the third junction terminal **148** of the flexible wiring board **104A** so as to be fed to the first junction terminal **145** of another flexible wiring board **104'** adjacent to the flexible wiring board **104A** through the second junction terminal **146** of the peripheral portion of the panel and the first circuit wiring **173** leading thereto. Then the signal is inputted from the first junction terminal **145** via the input terminal **144** of the flexible wiring board **104A'** to the drive IC **105**. A signal outputted by this drive IC **105** is fed to the inside of the panel via the output terminals of the flexible wiring board **104A'** and the electrode terminals **103** of the peripheral portion of the panel. In this way, the signal is fed to the electrode terminals **103** of the adjacent flexible wiring boards **104A**, **104A'**, . . . , in turn.

Since this liquid crystal module is provided with no common wiring board **307** or connector that would be disposed sideward of the panel in the prior art (see FIGS. **55** and **56**), the size of the module can be reduced compared with the prior art. Also, the number of parts can be reduced so that the weight of the module can also be reduced. Such reduction in the number of parts allows a reduction in material cost. Yet, the first junction terminal **145**, electrode terminals **103**, and second junction terminal **146** of the peripheral portion of the panel are connected to the input terminal **144**, output terminals **142**, third junction terminal **148** of the flexible wiring board **104A**, . . . collectively by means of the anisotropic conductive material **195**. Further, the connection process of the flexible wiring boards **104A**, . . . to the control board **111** can be achieved by such less work as to be equivalent to the connection process for the common wiring board of the prior art. The connection process for the connector can be completely omitted. As a result, the man-hour required can be reduced as a whole, compared with the prior art, leading to a cost reduction. A higher reliability also can be attained. Further, the control board **111** may be a board made of hard type glass epoxy, or otherwise of thin, soft type polyimide or polyester. The latter case allows further reduction in thickness and weight of the module.

FIGS. **19** to **21** each show a modification example of the above-described liquid crystal module. In the liquid crystal module shown in FIG. **19**, the fourth junction terminal **149** of the flexible wiring board **104T'** is not connected to the signal feed terminal of a control board **111A** (the control board **111A** is so designed that its shorter side line of an L-shape become short for weight reduction, as compared with the control board **111** shown in FIG. **17**). As a result, the number of points where the flexible wiring board is connected to the control board **111A** can be reduced, so that the man-hour required can be reduced with further cost reduction. In this case, the drive-use signal is fed to the portions of the peripheral portion of the panel corresponding to the flexible wiring boards **104A**, **104A'**, **104A''**, and **104T** via the aforementioned direct route, while the signal is fed to the portion of the peripheral portion of the panel corresponding to the flexible wiring board **104T'** via the aforementioned indirect route.

In the liquid crystal module shown in FIG. **20**, the fourth junction terminal **149** and the third circuit wiring **150** of the flexible wiring boards **104A**, **104A'**, and **104T'** have been cut off and removed together with the base material surface **140** (a control board **111B** is so designed that both its longer and shorter side lines of L-shape become short for weight reduction). As a result, the number of points where the

26

flexible wiring board is connected to the control board **111A** can be reduced, so that the man-hour required can be reduced with further cost reduction. In this case, there is no need of preparing different types of flexible wiring boards before assembling. Instead, the fourth junction terminal **149** and the third circuit wiring **150** may be cut off and removed before starting the assembling. Further, the aforementioned drive-use signal is fed to the portions of the peripheral portion of the panel corresponding to the flexible wiring boards **104A**, **104T** via the aforementioned direct route, while the signal is fed to the portions of the peripheral portion of the panel corresponding to the flexible wiring board **104A'**, **104A''**, and **104T'** via the aforementioned indirect route.

In the liquid crystal module shown in FIG. **21**, the portions of the flexible wiring boards **104A'**, **104A''**, and **104T'**, which are not connected to the control board **111B**, that project sideward of the peripheral portion of the panel are bent so as to be wound around the peripheral portion of the panel. Thereby, the number of points where the flexible wiring boards are connected to the control board **111B** can be reduced. Besides, the module size can be further reduced.

FIGS. **23** to **27** show another modification example of the above-described liquid crystal module. In the liquid crystal module shown in FIG. **23**, the control board **111** is partially overlapped on the flexible wiring board **104A** of the peripheral portion of the panel, and bonded therewith by an unshown adhesive (or double-sided tape) so as to be integrally attached. In this case, the strength of the module can be increased so that the its reliability also can be enhanced. Further, since there is no need of providing any additional reinforcement member for mounting the liquid crystal panel **120** and the control board **111**, the module can be designed to be further small-size and lightweight.

In the liquid crystal module shown in FIG. **24**, the control board **111** is integrally mounted on a surface opposite to the surface on which the electrode terminals **103** of the peripheral portion of the panel are provided, in such a way as to be partially overlapped therewith and bonded by an adhesive **112**. The portion of the flexible wiring board **104A** corresponding to the third circuit wiring **150** is bent at two points so that a step gap approximately equivalent to the thickness of the glass substrate **2** can be formed. In the assembling, first, the liquid crystal panel **120** and the control board **111** are bonded together. Then, the output terminals **142**, . . . of the flexible wiring board **104A** bent as shown in the figure are aligned with the electrode terminals **103**, . . . of the peripheral portion of the panel, while the fourth junction terminal **149** of the flexible wiring board **104A** is aligned with the signal feed terminal **151** of the control board **111**. Next, as shown in FIG. **28**, identical anisotropic conductive materials **195**, **195** are fed between the flexible wiring board **104A** and the peripheral portion of the panel and between the flexible wiring board **104A** and the control board **111**, so as to be provided between corresponding terminals. Then the corresponding terminals are thermally press bonded simultaneously by two thermal press bonding heads **115**, **116**. Otherwise, as shown in FIG. **29**, the corresponding terminals are thermally press bonded simultaneously by a thermal press head **117** having two head tips. Thereby, the number of connecting processes is reduced, so that the man-hour required can be reduced with cost reduction. Yet, as in the case shown in FIG. **23**, the strength of the module can be increased, so that the reliability is enhanced. As a result, the module can be designed for smaller size and less weight.

In the liquid crystal module shown in FIG. **25**, the control board **111** is mounted on a surface opposite to the surface on

which the electrode terminals **103** of the peripheral portion of the panel are provided in such a way that the control board **111** is bonded by the adhesive **112** so as not to project sideward of the peripheral portion of the panel. The flexible wiring board **104A** is bent so as to be wound around the peripheral portions of the liquid crystal panel **120** and the control board **111**. In this case, since the control board **111** does not project sideward of the liquid crystal panel **120**, the module size can be further reduced. Yet, as in the cases shown in FIGS. **23** and **24**, the strength of the module can be increased so that its reliability can be enhanced and that the module can be designed to be lightweight. In addition, when an electronic component **191** is mounted on the control board **111** as shown in FIG. **26**, spacers **113**, **113** may be provided between the glass substrate **102** and the control board **111** to ensure a clearance for the electronic component **191**.

In the liquid crystal module shown in FIG. **27**, a clip **110** made of a shape memorizing alloy or shape memory plastics having a U shape is used to pinch the peripheral portion of the panel and the control board **111** on the outer periphery of the flexible wiring board **104A**, thereby pressing the corresponding terminals. Numeral **114** denotes a buffer material. In this case, the anisotropic conductive material or the like can be omitted between the corresponding terminals, facilitating the connection of the terminals. As a result, the liquid crystal panel **120** can be easily assembled. Further, by virtue of its simple removal, any defective drive ICs **105** if any can be easily replaced with new ones. Yet, as in the cases shown in FIGS. **25** and **26**, the control board **111** does not project sideward of the liquid crystal panel **120**, so that the module size can be further reduced. Also, the strength of the module can be increased so that its reliability can be enhanced and that the module can be designed lightweight.

FIG. **30** is a perspective view of a liquid crystal display device **221**, which is an embodiment according to the seventh, eighth, and tenth aspects of the present invention. FIG. **31** is a plan view of the liquid crystal display device **221** around a flexible wiring board **230**. FIG. **32** is an exploded perspective view of the liquid crystal display device **221** around the flexible wiring board. FIG. **33** is a sectional view as viewed along the cutting-plane line X33—X33 of FIG. **31**. FIG. **34** is a sectional view as viewed along the cutting-plane line X34—X34 of FIG. **31**. In the following description, the liquid crystal display device **221** is taken as an example. The embodiments of the present invention can be applied to not only the liquid crystal display device **221** but also a wide variety of matrix-driven display devices including the EL display devices or plasma display devices.

In the embodiments, the liquid crystal display device (hereinafter, referred to as display device) **221** includes a display panel **228** having such an arrangement that liquid crystals **282** (see FIG. **36**) are injected between a pair of rectangular glass substrates **222**, **223** having transparent electrodes (not shown) formed on their opposite surfaces, the liquid crystals **282** being surrounded and sealed by a sealant **225** (see FIG. **36**). The region on the glass substrates **222**, **223** provided to the display panel **228**, where the transparent electrode are arranged, is defined as a display section **226** where the display of an image is implemented. As an example in which a drive IC **229** for driving the liquid crystal display device **221** is mounted on a peripheral portion **227** of one glass substrate **222** other than the range over which the glass substrate **222** overlaps the other glass substrate **223**, there are mounted ten flexible wiring boards **230**. A peripheral portion **227** is an L-shaped region extending along adjoining two sides of the glass substrate **222**.

Also, the flexible wiring board **230** has an insulating film **243** (see FIG. **33**) made of an electrically insulating material such as polyimide resin and polyester resin. On this insulating film **243**, various terminals and wiring lines later described are formed.

Common lines **231** for feeding signals or power to be fed in common to the flexible wiring boards **230** are formed continuously over the range over which the plurality of flexible wiring boards **230** are arranged on the peripheral portion **227**. A signal or drive-use power to be fed in common to the flexible wiring boards **230** is fed to the common lines **231** from a control board **232** via a connector **233**. The display device **221** is comprised of the display panel **228**, the plurality of flexible wiring boards **230**, and the control board **232**.

As shown in FIGS. **31** and **32**, an insulating film **234** is formed on the glass substrate **222** of the display panel **228** by forming a Ta₂O₅ film as an example. When source electrodes or gate electrodes within the display section **226** are formed on the insulating film **234**, the plurality of common lines **231** are formed from such a material as ITO, Ta, Ti, Mo, Cu, Au, Al, and Ag paste, in a single-layer or multi-layer structure so as to be 50 nm or more in thickness, a few μm—a few mm in line width, and 0.1 Ω/□—several 100's Ω/□ in resistance at a length ranging over approximately the entire length of the peripheral portion **227**. On the glass substrate **222** having the common lines **231** (see FIGS. **31** to **33**) formed thereon, an insulating film **235** is formed from such a material as SiN, SiO₂, Ta₂O₅, or polyimide so as to have a plurality of through holes **236**.

On the insulating film **235**, there are formed a plurality of signal lines **237**, for example, each connected to a group of pixels corresponding to each row of the whole pixels arrayed in a matrix within the display section **226**; and signal-use junction common lines **238** and power-use junction common lines **239** each having a length ranging between opposing terminals of adjacent flexible wiring boards **230** on the peripheral portion **227**. The junction common lines **238**, **239** are formed from such a material as ITO, Ta, Ti, Mo, Cu, Au, Al, and Ag paste in a single-layer or multilayer structure so as to be 50 nm or more in thickness, a few μm—a few mm in line width, and 0.1 Ω/□—several 100's Ω/□ in resistance. The junction common lines **238**, **239**, as shown in FIGS. **31** and **32**, are arrayed in a direction perpendicular to the direction in which the plurality of flexible wiring boards **230** are arrayed on the peripheral portion **227** (lateral direction in FIGS. **31** and **32**). Rectangular connecting portions **240** are formed at an equal pitch at end portions of the signal lines **237**. The connecting portions **240** are formed from such a material as ITO, Ta, Ti, Mo, Cu, Au, Al, and Ag paste in a single-layer or multilayer structure so as to be 50 nm or more in thickness, a few μm—a few mm in line width, and 0.1 Ω/□—several 100's Ω/□ in resistance. The plurality of connecting portions **240** are arrayed along the aforementioned array direction.

On the peripheral portion **227** of the glass substrate **222**, there are formed a plurality of lead-in lines **242** each one end of which is connected to a common line **231** via a through hole **236** of insulating film **235** and the other end of which extends toward an end of the peripheral portion **227**. The end portion of each lead-in line **242** is connected to rectangular connecting portions **241** arrayed along the aforementioned array direction on the peripheral portion **227**. An insulating film **263** is formed so as to cover the common lines **231** and the lead-in lines **242** as described above.

On the other hand, the flexible wiring boards **230** are each formed into rectangular shape and generally referred to as

TAB (Tape Automated Bonding) boards. The flexible wiring boards **230** have input terminals **244**, **245** connected to the input-side junction common lines **238**, **239**, respectively, on the rear surface of the base material **243** with a flexibility opposite to the glass substrate **222**. These input terminals **244**, **245**, as shown in FIGS. **31** and **32**, are arrayed in a direction perpendicular to the aforementioned array direction at one end portion of the flexible wiring boards **230** along the array direction.

Further, a plurality of electrode terminals **248** (see FIG. **32**) to be connected to the plurality of connecting portions **240** at an end portion of the flexible wiring boards **230** which end portion is adjacent to the aforementioned one end portion and which confronts the glass substrate **222** are arranged along the array direction. Besides, a plurality of electrode terminals **249** to be connected to the connecting portions **241**, respectively, are also arrayed along the aforementioned array direction. On the flexible wiring boards **230**, output terminals **246**, **247** for outputting signals of the same type as those inputted to the input terminals **244**, **245** are arrayed in a direction perpendicular to the aforementioned array direction, at an end portion of the flexible wiring boards **230** opposite to the end portion where the input terminals **244**, **245** are located, in the same arrayed state as in the input terminals **244**, **245**. The input terminals **244**, **245** and the output terminals **246**, **247** are formed from such a material as Sn- or Au-plated Cu and aluminum so as to be 10–60 μm in thickness and a few μm—a few mm in line width.

Meanwhile, accommodating hole **250** (see FIG. **33**) for accommodating the IC **229** are formed at positions away from the end portions of the flexible wiring boards **230**. The IC **229** within the accommodating holes **250** is firmly coated with a protective resin layer **251**, for example, of epoxy resin. The IC **229** is provided with a plurality of electrode bumps **252**. In the flexible wiring boards **230**, a plurality of connecting lines **253**, **254**, **255** are formed for connecting the input terminals **244**, **245**, the electrode terminals **248**, **249**, and the output terminals **246**, **247** to their corresponding electrode bumps **252** of the IC **229**. Further, alignment marks **290** (see FIG. **32**) are provided at positions corresponding to some of the electrode terminals **249**.

In the flexible wiring boards **230**, a connecting line **256** is formed for connecting the input terminal **245** directly to the output terminal **247**, while a branch line **257** is formed for connecting the connecting line **256** to its corresponding electrode bump **252** of the IC **229**. Some signals inputted from the input terminals **244** to one flexible wiring board **230** are to be transferred to another adjacent flexible wiring board **230**. To implement such transfer, a plurality of internal lines **258** for connecting at the inside of the IC **229** the input-use connecting line **253** directly to an output-use connecting line **291** (see FIG. **32**) in correspondence to the signal to be transferred are formed within the IC **229**. In the flexible wiring boards **230**, a chip capacitor **260** for signal adjustment is connected to the connecting line **256** and part of the connecting lines **253**. Thereby, any differences in display grade among the ICs **229** of the flexible wiring boards **230** are reduced.

Connection between the above-described display panel **228** and the flexible wiring boards **230** is achieved by using an anisotropic conductive film **259**.

FIG. **35** is a flow chart showing the process of manufacturing the display device **221**, which process is an embodiment according to the tenth aspect of the present invention. FIG. **36** is a sectional view showing the manufacturing process.

The manufacturing process of the present embodiment is now described with reference to the aforementioned figures. In mounting the flexible wiring boards **230** onto the display panel **228**, at step b1 of FIG. **35**, the anisotropic conductive film **259** is applied in adhesion or coating onto the connecting portions of a predetermined plurality of flexible wiring boards **230** in the peripheral portion **227** of the display panel **228**. At step b2, the flexible wiring boards **230** are aligned with a predetermined plurality of positions of the peripheral portion **227** of the display panel **228**. More specifically, while the peripheral portion **227** of the display panel **228** is opposed to the plurality of flexible wiring boards **230**, the connecting portions **240**, **241**, the electrode terminals **248**, **249**, the junction common lines **238**, **239** and input/output terminals **244**, **245**, **246**, **247** of one flexible wiring board **230** located at its both ends in the array direction are aligned for each flexible wiring board **230** in one-to-one correspondence, respectively.

Then, at step b3, the display panel **228**, on which the aligned flexible wiring boards **230** are mounted, are heated by a thermal press head **261** having a single or plurality of press portions **262** which is shown in FIG. **36** and which have such a shape as to press the connecting portions to the display panel **228** of each flexible wiring board **230**. By this heating, thermal press bonding is achieved, as shown in FIG. **36**, between the connecting portions **240**, **241** and the electrode terminals **248**, **249**, and between the junction common lines **238**, **239** and the input/output terminals **244**, **245**, **246**, **247** located at both ends in the array direction of one flexible wiring board **230**. Thus, the process of mounting a plurality of flexible wiring boards **230** onto the display panel **228** is completed.

Through this process, opposing electrodes of the connecting portions **240**, **241**, the terminals **244**, **245**, **246**, **247**, **248**, **249**, and the junction common lines **238**, **239** can be electrically connected collectively.

Some advantages can be offered by virtue of the above-described structure of the display device **221**, i.e. a structure that the connecting terminals **244** to **247** of the display panel **228** and the flexible wiring boards **230** include connecting terminals arranged in parallel to the array direction of the flexible wiring boards **230** in the display panel **228**, and connecting terminals arrayed in a direction perpendicular to the array direction. The advantages are, for example, that the size of the flexible wiring boards **230** along the array direction can often be reduced further than a case where all the connecting terminals **244** to **247** are arrayed in parallel to the array direction, and that resistance due to distribution of the common lines can be lowered so that the display grade can be maintained at successful level.

The above-described structure of the display panel **228** also allows the area occupied by the display device **221** to be reduced substantially. This is due to the fact that, compared with the prior art in which a further wiring board is used separately of the display panel **228** and the flexible wiring boards **230** so that the common lines **231** are provided to the separately provided wiring board as shown in FIG. **55**, the present embodiment allows the separate wiring board to be omitted.

Thus, in the present embodiment, the display device **221** can be provided in smaller size, thinner thickness, and less weight. Further, the display device **221** is less affected by any external force by virtue of its reduced size, so that the reliability of the display device **221** can be improved.

The region where the anisotropic conductive film **259** is provided, may extend to such areas as equivalent to the areas

of the terminals 244, 245, 246, 247, 248, and 249, so that the terminals 244, 245, 246, 247, 248, and 249 may be coated independently of one another, or otherwise may extend over the outer whole region of the insulating film 263. Also, solder, photo-setting resins, or other connecting materials may be used instead of the anisotropic conductive film 259.

In this way, as shown in FIG. 30, a plurality of flexible wiring boards 230 which have the same wiring pattern and which serve for, for example, driving scanning lines of the display device 221 are connected to the display panel 228 along one side of the display device 221. Along another side of the display device 221, flexible wiring boards 230 which have a wiring pattern different from that of the foregoing flexible wiring boards 230 and which serve for, for example, driving data lines of the display device 221 are connected to the display panel 228. Further, at a corner portion 264 of the peripheral portion 227 of the glass substrate 222, a control board 232 for feeding signals for driving the display device 221 is connected to the common lines 231 and the junction common lines 238, 239 via the connector 233.

In operation of the display device 221, a drive-use signal is fed from the control board 232 to the common lines 231 and the junction lines 238 of the peripheral portion 227 of the display device 221 via the connector 233. The signal drives the IC 229 from the connecting portions 241 and terminals 244, 245, as shown in FIGS. 31 and 32, via the connecting lines 253, 251 of the flexible wiring boards 230, while output signals of the IC 229 are fed to the pixel electrodes (not shown) of the display device 221 via the connecting lines 254 and the electrode terminals 248. Thereby, the display device 221 is driven.

Also, the above drive-use signal is branched by the junction common line 238 and fed to the input terminals 244 of a flexible wiring board 230 adjacent to the foregoing flexible wiring board 230 via the input terminals 244 and connecting line 253 of the flexible wiring board 230, lower lines or internal lines 258 of the IC 229, the connecting lines 291, the output terminals 246, and the junction common lines 238. Then the signal is fed from the input terminals 244 via the connecting lines 253 of the adjacent flexible wiring boards 230 to the drive IC 229. A signal outputted by the drive IC 229 is fed to the inside of the display section 226 of the display panel 228 via the output terminals 246 of the flexible wiring boards 230 and the connecting portions 240 of the peripheral portion 227.

In this way, the above drive-use signals are fed to the connecting portions 240 of a plurality of the flexible wiring boards 230 mounted on one side of the peripheral portion 227 of the liquid crystal display device 221. The same drive-use signals are similarly fed also to the connecting portions 240 of the flexible wiring boards 230 (see FIG. 30) mounted on another side of the liquid crystal display device.

Since the liquid crystal display device 221 is provided with no common wiring board 307 (see FIGS. 55 and 56) that would be disposed sideward of the liquid crystal display device 221 in the prior art, the size of the liquid crystal display device 221 can be reduced, so that the liquid crystal display device 221 can be offered in less thickness and weight. This also allows cost reduction of the liquid crystal display device 221.

Yet, connection between the junction lines 238, 239 of the peripheral portion 227 of the liquid crystal display device 221 and the input terminals 244, 245 of the flexible wiring boards 230, connection between the output terminals 246, 247 of the flexible wiring boards 230 and the junction lines 238, 239, and connection between the connecting portions

240, 241 and the electrode terminals 248, 249 of the flexible wiring boards 230 are achieved collectively by means of the anisotropic conductive film 259. As a result, the connecting process for manufacturing the liquid crystal display device 221 can be reduced, so that the rate of occurrence of any defectives in the connecting process is reduced, and that the production yield in the assembling process is improved. Also, a cost reduction can be expected in terms of the manufacturing process.

Further, in the above-described embodiment, the common wiring board in the prior art is not adopted, so that the connecting process between the flexible wiring boards 230 and the common wiring board is eliminated. Accordingly, the man-hour required is reduced compared with the prior art, with cost reduction. Also, since the number of parts is reduced, the reliability of the liquid crystal display device 221 can be improved substantially.

In the above-described embodiment, a signal to be transferred from one to another among the flexible wiring boards 230 is transferred via the junction common lines 238, 239 and the connecting line 256 within the flexible wiring boards 230. Accordingly, wire resistance involved in the transfer of a signal can be reduced more than when the signal is transferred by using only the common lines 231 formed on the peripheral portion 227 of the display panel 228 by the thin-film technique. Also, the input terminals 244, 245, output terminals 246, 247, and electrode terminals 248, 249 of the flexible wiring boards 230 can be increased in line width and, besides, the junction common lines 238, 239, connecting portions 240, 241 of the display panel 228 can also be increased in line width. As a result, connection resistance that results when the flexible wiring boards 230 are mounted onto the display panel 228 can be reduced.

In the flexible wiring boards 230 of this embodiment, it is also possible that a resin having an electrical insulation property is applied to the surface on which the input terminals 244, 245, thereby forming an insulating coat, so that the plurality of input terminals 244, 245, terminals 248, 249, connecting terminals 253, 254, 255, 291, 256, and output terminals 246, 247 are increased in reliability on their mutual electrical insulation.

FIG. 37 is a plan view of a flexible wiring board 230a which is a modification example of the flexible wiring boards 230 of the foregoing embodiment, for use in the liquid crystal display device 221 of the present invention. In this modification flexible wiring board 230a, corner portions at both ends of a side of an insulating film 243 (see FIGS. 33, 34) of the flexible wiring boards 230 of the foregoing embodiment, the side being opposed to the display panel 228, have been cut out to form cutouts 266.

If the signal inputted to one of the plurality of input terminals 244 formed on the flexible wiring board 230, is a signal of a first type that should be inputted to the IC 229 mounted on the flexible wiring board 230, the first type signal is inputted from an input terminal 244a through a connecting line 253 to the IC 229. The signal is processed at the inside of the IC 229, where a different waveform signal is generated and then passed through a connecting line 291 and a terminal 246a, thus fed to an adjacent flexible wiring board 230. On the other hand, if the signal to be inputted as above is a signal of a second type that, for example, is inputted to the IC 229 and should be transferred to another adjacent flexible wiring board 230 without being changed in signal waveform, then the second type signal is inputted to an input terminal 244b that is connected to the IC 229 via the connecting line 253 and besides connected directly to an

output terminal **246b** corresponding to the input terminal **244b** via the connecting line **256**.

If the signal to be inputted as above is a signal of a third type that, for example, is transferred to another adjacent flexible wiring board **230** or other electrodes on the panel (e.g. common electrodes) without being inputted to the IC **229**, then the third type signal is inputted to an input terminal **244c** that is connected directly to an output terminal **246c** corresponding to the input terminal **244c** via the connecting line **256**. The input terminal **245** is connected to the corresponding output terminal **247** via the connecting lines **256**, while part of the connecting line **256** is connected to the IC **229** via a branch line **257**.

The flexible wiring board **230a** as described above is mounted to the display panel **228** in the same assembling process as in the foregoing embodiment. In this process, clearances due to the cutouts **266** are formed between a plurality of adjacent flexible wiring boards **230a** mounted on the display panel **228**. Through these clearances, as shown in FIG. **37**, part of the input terminals **244b**, **244c**, part of the connecting lines **256**, and part of the output terminals **246b**, **246c** are exposed to outside. Accordingly, when this flexible wiring board **230a** is used, the clearances are coated with an insulating film made of such a material as SiN and polyimide, as an example, on the panel side.

FIG. **38** is a perspective view of a liquid crystal display device **221a** which is a second embodiment according to the seventh aspect of the present invention. FIG. **39** is a sectional view of this embodiment. The liquid crystal display device **221a** of this embodiment is similar to the liquid crystal display device **221** of the foregoing first embodiment, where corresponding parts are designated by same reference numerals. In the second embodiment, the plurality of flexible wiring boards **230** are connected to the peripheral portion **227** of the display panel **228**. Thereafter, portions of the flexible wiring boards **230** that project outward of the peripheral portion **227** of the display panel **228** are bent so as to be wound around the peripheral portion **227** of the display panel **228**, as shown in FIGS. **38** and **39**. By this bending process, the display panel **228** of the liquid crystal display device **221** is pinched by the flexible wiring boards **230** at their peripheral portion **227**.

Thereby, the size of the liquid crystal display device **221a** can be further reduced by the bending extent of the flexible wiring boards **230**.

In the present embodiment, it is also possible as shown in FIG. **39** that a clip **267** made of a shape memorizing alloy or shape memory plastics having a U shape in section is used to pinch the display panel **228** by its peripheral portion **227** on the outer peripheral side of the bent flexible wiring boards **230** and, in this state, the junction lines **238**, **239** and the connecting portions **240**, **241** and their corresponding input terminals **244**, **245**, output terminals **246**, **247**, and terminals **248**, **249** are press bonded with each other. Thereby, the terminals for connection of the display panel **228** and the flexible wiring boards **230** can be connected each other simply and firmly. Also, in doing this, in order to determine the interval between the flexible wiring boards **230** and the glass substrate **222** and the interval between the flexible wiring boards **230** and the clip **267**, a spacer **292** is mounted to the flexible wiring boards **230**.

Therefore, in the present embodiment, the same effects as described in the foregoing embodiment can be achieved. Besides, the reliability of connection between the display panel **228** and the plurality of flexible wiring boards **230** can be further improved.

FIG. **40** is a plan view of a liquid crystal display device **221b** which is a third embodiment according to the seventh aspect of the present invention. FIG. **41** is a sectional view taken along the line X41—X41 of FIG. **40**. FIG. **42** is a sectional view taken along the line X42—X42 of FIG. **40**. This embodiment is similar to the foregoing first embodiment, where corresponding parts are designated by same reference numerals.

The first remarkable point of the present embodiment is that there are formed no common lines **231** on the display panel **228** of the first embodiment. Accordingly, signals to be transferred mutually between the plurality of flexible wiring boards **230** mounted on the display panel **228** are transferred by a plurality of junction lines **238**, **239** formed on the display panel **228**, and a plurality of input terminals **244**, **245** and a plurality of output terminals **246**, **247** in the flexible wiring boards **230**.

This makes it possible to prevent occurrence of such a wiring state that the common lines **231** and signal lines **237** extending inside the display panel **228** intersect each other as in the first embodiment. Therefore, it is possible to omit the structure that the common lines **231** and the signal lines **237** are partially laminated on the display panel **228** with an insulating film **234** interposed therebetween. As a result, such events can be prevented that the signal lines **237** may cause connection failure or disconnection on account of the step gap due to the film thickness of the common lines **231**, or that the common lines **231** and the signal lines **237** may be shortcircuited. This allows the manufacturing yield of the liquid crystal display device **221b** to be improved, and the reliability of the liquid crystal display device **221b** to be enhanced substantially. Also, since the present embodiment permits the process of forming the common lines **231** to be omitted, the manufacturing process of the liquid crystal display device **221b** can be simplified.

The second remarkable point of the present embodiment is that all of signals to be transferred from the input terminals **244**, **245** to the output terminals **246**, **247** are passed through the inside of the IC **229**. More specifically, all the input terminals **244**, **245** of the flexible wiring boards **230** are connected to the input-use terminals **268** of the IC **229** by a plurality of connecting lines **253a**, respectively. An output-use terminal **268** of the IC **229** mounted on the flexible wiring boards **230** is connected to all the output terminals **246**, **247** by a plurality of connecting lines **255a**.

Accordingly, a plurality of connecting lines formed by pulling around on the flexible wiring boards **230** along the second direction in order to connect the input terminals **244**, **245** directly to the output terminals **246**, **247** can be omitted. As a result, the structure of the flexible wiring boards **230** can be simplified.

The third remarkable point of the present embodiment is that the input terminals **244**, **245**, the output terminals **246**, **247**, and the electrode terminals **248**, **249** in the first embodiment are arrayed in the second direction (up and down direction in FIGS. **32** and **40**) perpendicular to the first direction (right and left direction in FIGS. **31** and **40**) in which the lead-in lines **242** in the display panel **228** are arrayed. Thereby, in some cases, the length of the flexible wiring boards **230** along the first direction can be reduced, compared with the case where the electrode terminals **248**, **249** are arrayed in the first direction as in the first embodiment. Thus, the liquid crystal display device **221** can be reduced in size.

The fourth remarkable point of the present embodiment is that part of a plurality of input/output terminals **268** in the IC

229 mounted on the flexible wiring boards 230 are arrayed in the second direction of the IC 229. This makes it possible to reduce the length of the IC 229 in the first direction, so that the liquid crystal display device 221b can be downsized.

FIG. 43 is a plan view of a liquid crystal display device 221c which is a fourth embodiment according to the seventh aspect of the present invention. FIG. 44 is a sectional view taken along the line X44—X44 of FIG. 43. This embodiment is similar to the third embodiment, where corresponding parts are designated by same reference numerals.

The remarkable point of the present embodiment is that there are formed a plurality of connecting lines 269 for connecting all the input terminals 244, 245 and all the output terminals 246, 247 of the flexible wiring boards 230 separately and directly in the structure of the foregoing third embodiment. The connecting lines 269 are formed of such a material as Sn- or Au-plated Cu. One end of the connecting lines 269 is connected to the input terminals 244, 245, while the other end is connected to the output terminals 246, 247. An intermediate portion of the connecting lines 269 is, as shown in FIG. 44, fixed at a position around the accommodating hole 250 which accommodates the ICs 229 and which is formed in the base material 243 of the flexible wiring boards 230, by using a protective resin 251 in the flexible wiring boards 230. In the connecting lines 269, underneath the IC 229 there are formed connecting portions 270 to be connected to a plurality of electrode bumps 252 of the IC 229.

In the above-described embodiment, the same effects as described in the foregoing embodiments can be achieved. Further, since the present embodiment allows the internal lines 258 for use of signal transmission of the ICs 229, which have been used in the third embodiment, to be omitted, the IC 229 can be simplified in their internal structure and therefore reduced in size. This makes it possible to downsize the structure of the liquid crystal display device 221c.

FIG. 45 is a sectional view showing the structure of a first modification example of the above-described embodiment, or a sectional view of the display panel 228 taken at a cutting position corresponding to FIG. 44. As shown in FIG. 45, the IC 229 to be mounted on the flexible wiring boards 230 may be also arranged on the side of the flexible wiring boards 230 on which the connecting lines 269 are formed.

In such a modification example, the effects of the present embodiment can be achieved.

FIG. 46 is a sectional view showing the structure of a second modification example of the present embodiment, or a sectional view of the display panel 228 taken at a position corresponding to FIG. 44. As shown in FIG. 46, the accommodating holes 250 are not formed in the flexible wiring boards 230 of this modification example. Accordingly, in the flexible wiring boards 230 of this modification example, the connecting lines 269 are formed on the base material 243 of the flexible wiring boards 230. Also, the IC 229 to be mounted are arranged on the base material 243 in the flexible wiring boards 230, for example, on the side on which the connecting lines 269 of the flexible wiring boards 230 are formed. Even in such a modification example, the effects of the present embodiment can be achieved.

FIG. 47 is a plan view of a liquid crystal display device 221 which is a fifth embodiment according to the seventh aspect of the present invention. FIG. 48 is a sectional view taken along the line X48—X48 of FIG. 47. This embodiment is similar to the foregoing third embodiment, where corresponding parts are designated by same reference numerals.

In this embodiment, the flexible wiring boards 230 have the accommodating holes 250 formed therein, where the IC 229 to be mounted are accommodated in the accommodating holes 250 and fixed to the base material 243 of the flexible wiring boards 230 by the protective layer 251. The input terminals 244, 245 and the output terminals 251. 246, 247 are formed on one surface of the base material 243. A plurality of connecting lines 271 are formed on the base material 243 so as to directly connect the input terminals 244, 245 and the output terminals 246, 247 in such a wiring state as to detour the accommodating holes 250. The connecting lines 271 are made of such a material as Sn- or Au-plated Cu. The chip capacitor 260 is connected to specified connecting lines 271 such as one corresponding to the power line.

Some of the connecting lines 271 should be connected to not only the output terminals 246, 247 but also the electrode bumps 252 of the IC 229. A plurality of connecting lines 272 for connection between the connecting lines 271 and the electrode bumps 252 of the IC 229 are formed on the base material 243 in order to connect the connecting lines 271 to the IC 229. More specifically, an insulating film 273 is formed on a region where at least the connecting lines 272 are coated. The insulating film 273 has through holes 274 formed at positions corresponding to the connecting lines 272. Over the range of the insulating film 273 and the range of the base material 243, the plurality of connecting lines 271 are formed. The connecting lines 271 are electrically connected to their corresponding connecting lines 272 via the through holes 274 of the insulating film 273. In such an embodiment, the same effects as described in the foregoing embodiments can be achieved.

In particular, since the connecting lines 271 and the connecting lines 272 are provided in laminate structure, wiring density in the flexible wiring boards 230 can be increased, so that the flexible wiring boards 230 can be designed for smaller size.

FIG. 49 is a plan view of a liquid crystal display device 221e which is a sixth embodiment according to the seventh aspect of the present invention. FIG. 50 is a sectional view taken along the line X50—X50 of FIG. 49. This embodiment is similar to the foregoing fifth embodiment, where corresponding parts are designated by same reference numerals.

The plurality of input terminals 244, 245 are formed on one surface of the base material 243 of a plurality of flexible wiring boards 230 used in this embodiment. On the one surface, there are formed a plurality of connecting lines 275 one end of which is connected to the input terminals 244, 245 and extends along the second direction (up and down direction of FIG. 49) and the other end of which is positioned in an extension of the first direction (right and left direction of FIG. 49), and a plurality of connecting lines 272 each extending from the other ends of the connecting lines 275 toward the electrode bumps 252 of the ICs 229. Also, on the one surface, there are formed a plurality of output terminals 246, 247 and a plurality of connecting lines 276 one end of which is connected to the output terminals 246, 247 and extends along the second direction (up and down direction of FIG. 49) and the other end of which is positioned in an extension of the first direction (right and left direction of FIG. 49) of the IC 229.

In the flexible wiring boards 230, through holes 278 are formed at positions corresponding to the other ends of the connecting lines 271, 271. On a surface opposite to the surface on which the connecting lines 271 of the flexible

wiring boards 230 are formed, bypass wirings 277 are formed separately between the through holes 278 corresponding to the connecting lines 271 on the signal output side and the through holes 278 corresponding to the connecting lines 271 on the signal output side. The bypass wirings 277 are made of such a material as Sn- or Au-plated Cu. One end of the bypass wirings 277 is connected to the other end of the connecting lines 271 via the through holes 278 on the signal input side, while the other end of the bypass wirings 277 is connected to the other end of the connecting lines 271 via the through holes 278 on the signal output side.

In such an embodiment, the same effects as described in the foregoing embodiments can be achieved. In particular, in this embodiment, the connecting lines 271, 271, the connecting lines 272, and the bypass wirings 277 are formed so as to be separated between both surfaces of the base material 243 and overlaid on each other. Accordingly, wiring density in the both surfaces of the flexible wiring boards 230 can be increased so that the flexible wiring boards 230 and the liquid crystal display device 221e can be designed for smaller size.

FIG. 51 is a sectional view of a liquid crystal display device 221f which is a seventh embodiment according to the seventh aspect of the present invention. FIG. 52 is a plan view of the liquid crystal display device 221f. This embodiment is similar to the first embodiment, where corresponding parts are designated by same reference numerals.

This embodiment is described in a case where the liquid crystal display device 221f is the active matrix driven type. The liquid crystal display device 221f of this embodiment has a pair of glass substrates 222, 223, where a plurality of pixel electrodes 279 arrayed in a matrix are formed on the glass substrate 222, and opposite electrodes 280 opposed to the pixel electrodes 279 are formed on the glass substrate 223. On the glass substrates 222, 223, the regions where the pixel electrodes 279 and the opposite electrodes 280 are arrayed constitute a display section 226. A liquid crystal layer 282 is sandwiched between the glass substrates 222, 223, the peripheral portion of the display section 226 is sealed by a sealant 225.

In the liquid crystal display device 221f of this embodiment, the plurality of common lines 231 are formed over the entire regions including a region outer than the sealant 225, a region coated with the sealant 225, and a region inner than the sealant 225 and yet other than the display section 226. Of these common lines 231, those common lines 231 located inward of the sealant 225 are coated with an insulating film 283 such as a known orientation film or protective film (passivation film).

In this embodiment, the region where the common lines 231 are formed is made larger than the peripheral portion 227 of the display panel 228. This allows the area of the peripheral portion 227 to be reduced and therefore the liquid crystal display device 221f to be downsized. Otherwise, arrangement density of the common lines 231 can be lowered, so that the common lines 231 can be prevented from shortcircuiting among themselves or from occurrence of insulating failures. As a result, the reliability of the liquid crystal display device 221f can be improved. Moreover, the production yield of the liquid crystal display device 221f can be improved at the same time.

Further, some of the common lines 231 are arranged by making the use of the region of the display panel 228 inner than the sealant 225 except the region of the opposite electrodes 280, whereby the line width of the common lines

231 is widened and the resistance is lowered. As a result, time delay of a signal transferred through the common lines 231 is reduced. By this advantage, the signal transferred, when being an image signal, can be prevented from inclusion of noise that might cause the waveform of the image signal to be deformed undesirably. Thus, the resulting display image can be prevented from occurrence of failures.

FIG. 53 is a sectional view of a liquid crystal display device 221g which is an eighth embodiment according to the seventh aspect of the present invention. FIG. 54 is a plan view of the liquid crystal display device 221g. This embodiment is similar to the foregoing seventh embodiment, where corresponding parts are designated by same reference numerals.

The liquid crystal display device 221g of this embodiment has nearly the same structure as the liquid crystal display device 221f. This embodiment is characterized in the arrangement of common lines 231 and common lines 231a. In the liquid crystal display device 221g of this embodiment, the plurality of common lines 231, 231a are formed over the entire regions including a range on the glass substrate 222 outer than the sealant 225, a region coated with the sealant 225, and a region inner than the sealant 225 and yet around the peripheral portion of the display section 226. Of these common lines 231, 231a, some of the common lines 231a are provided as signal lines which transfer signals that do not easy pick up noise of the opposite electrodes 280 such as a clock signal. Further, the common lines 231, 231a are coated with an insulating film 283 such as a known orientation film or protective film (passivation film).

Of the regions where the common lines 231 are arranged, the region inner than the sealant 225 and yet around the peripheral portion of the display section 226 is defined as follows. When the liquid crystal display device 221g is used as, for example, a display device for a computer, the region included in the display section 226 and around the peripheral portion of the display section 226 is in some cases such that the image being displayed cannot be viewed from outside due to an effect of the casing by which the liquid crystal display device is mounted to the computer or the like, or other reasons. Thus, the region around the peripheral portion of the display section 226, although included in the display section 226, will often not contribute to the image displaying substantially. In such cases, formation of the common lines 231 around the peripheral portion of the display section 226 will to no extent affect a display image, as it is viewed from outside.

Therefore, in the above-described case, the common lines 231 may be formed on the glass substrate 222. In such an embodiment, the same effects as described in the seventh embodiment can be achieved.

In the seventh aspect of the present invention, the connecting material for electrically connecting the display panel 228 to the flexible wiring boards 230 is not limited to the anisotropic conductive film 259. Instead, connection techniques other than the anisotropic conductive film 259 may be used, such as connection by the use of solder or photo-setting resins and clip press bonding.

The invention being thus described, it will be obvious that the same may be varied in many ways. Such variations are not to be regarded as a departure from the spirit and scope of the invention, and all such modifications as would be obvious to one skilled in the art are intended to be included within the scope of the following claims.

39

What is claimed is:

1. A panel assembly comprising:
 a flat panel having a plurality of electrode terminals disposed along a peripheral portion of one surface;
 an integrated circuit mounted on a flexible wiring board and electrically connected to said electrode terminals for driving the panel;
 an insulating layer having a first and second surface, with said electrode terminals located on said first surface;
 a circuit wiring extending along the peripheral portion for transferring an external signal to the panel, located on said second surface below said first surface so as to be insulated from said electrode terminals;
 junction terminals spaced from each other in conducting contact with said circuit wiring, said junction terminals penetrating said insulating layer and having portions located on said first surface; and
 said flexible wiring board including on one side input and output terminals leading to the integrated circuit;

40

wherein the one side of the flexible wiring board is overlaid on the peripheral portion of the panel so that the junction terminals and electrode terminals of the panel are electrically connected to the input and output terminals of the flexible wiring board, respectively.
 2. The panel assembly as claimed in claim 1, wherein the junction terminals and electrode terminals of the panel are electrically connected to the input and output terminals, by an anisotropic conductive material.
 3. The panel assembly as claimed in claim 1, wherein an electronic component is mounted on the flexible wiring board.
 4. The panel assembly as claimed in claim 1, wherein said panel is a liquid crystal display.
 5. The panel assembly as claimed in claim 3, wherein the electronic component is a capacitor.

* * * * *