



US 20100210142A1

(19) **United States**

(12) **Patent Application Publication**  
**McGrath et al.**

(10) **Pub. No.: US 2010/0210142 A1**  
(43) **Pub. Date: Aug. 19, 2010**

(54) **ELECTRICAL CONNECTOR**

**Publication Classification**

(75) Inventors: **James L. McGrath**, Bloomington, IL (US); **David W. Mendenhall**, Naperville, IL (US); **Hecham K. Elkhatib**, Aurora, IL (US); **William J. MacKillop**, Wheaton, IL (US); **Alan A. Raclawski**, Schaumburg, IL (US)

(51) **Int. Cl.**  
*H01R 13/66* (2006.01)  
*H05K 9/00* (2006.01)  
*H01R 13/648* (2006.01)  
(52) **U.S. Cl.** ..... **439/620.22**; 174/350; 439/607.01

(57) **ABSTRACT**

The cable assembly may include a plug connector, a cable, and a connector. The plug connector may include a housing and a board assembly. The board assembly may include a printed circuit board. The edge of the printed circuit board may be enclosed with a material. The material may be an overmolded plastic or a coating of a material. In order to reduce the crosstalk in the areas where the cable shield is removed, a shielding assembly may be used. The shielding assembly may provide 360 degrees of shielding for the wire pair at the location where the cable shield is removed. The printed circuit board may have a trace layer, a core layer, and a ground plane layer. The ground plane layer may have a portion which is a solid layer and another portion which is a non-solid layer.

Correspondence Address:  
**LEYDIG VOIT & MAYER, LTD**  
**TWO PRUDENTIAL PLAZA, SUITE 4900, 180**  
**NORTH STETSON AVENUE**  
**CHICAGO, IL 60601-6731 (US)**

(73) Assignee: **Cinch Connectors, Inc.**, Lombard, IL (US)

(21) Appl. No.: **12/388,383**

(22) Filed: **Feb. 18, 2009**

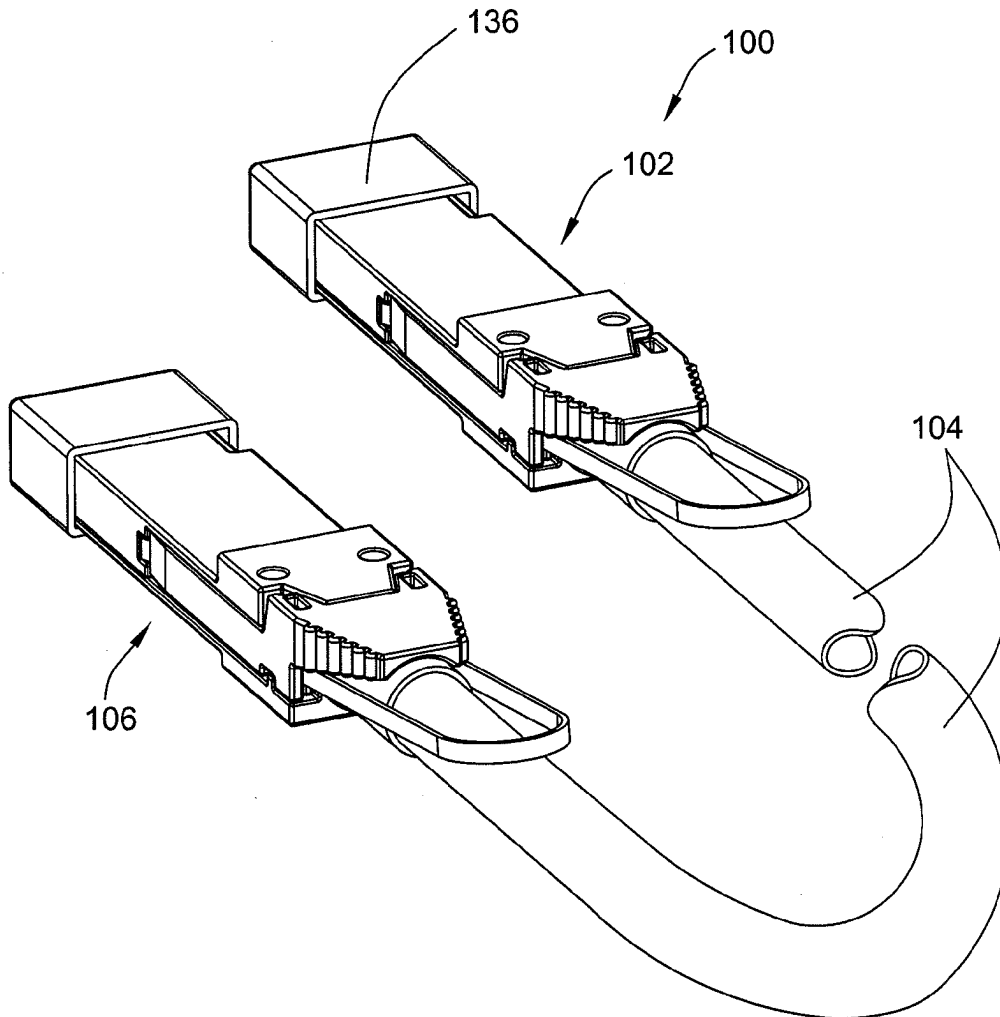

FIG. 1

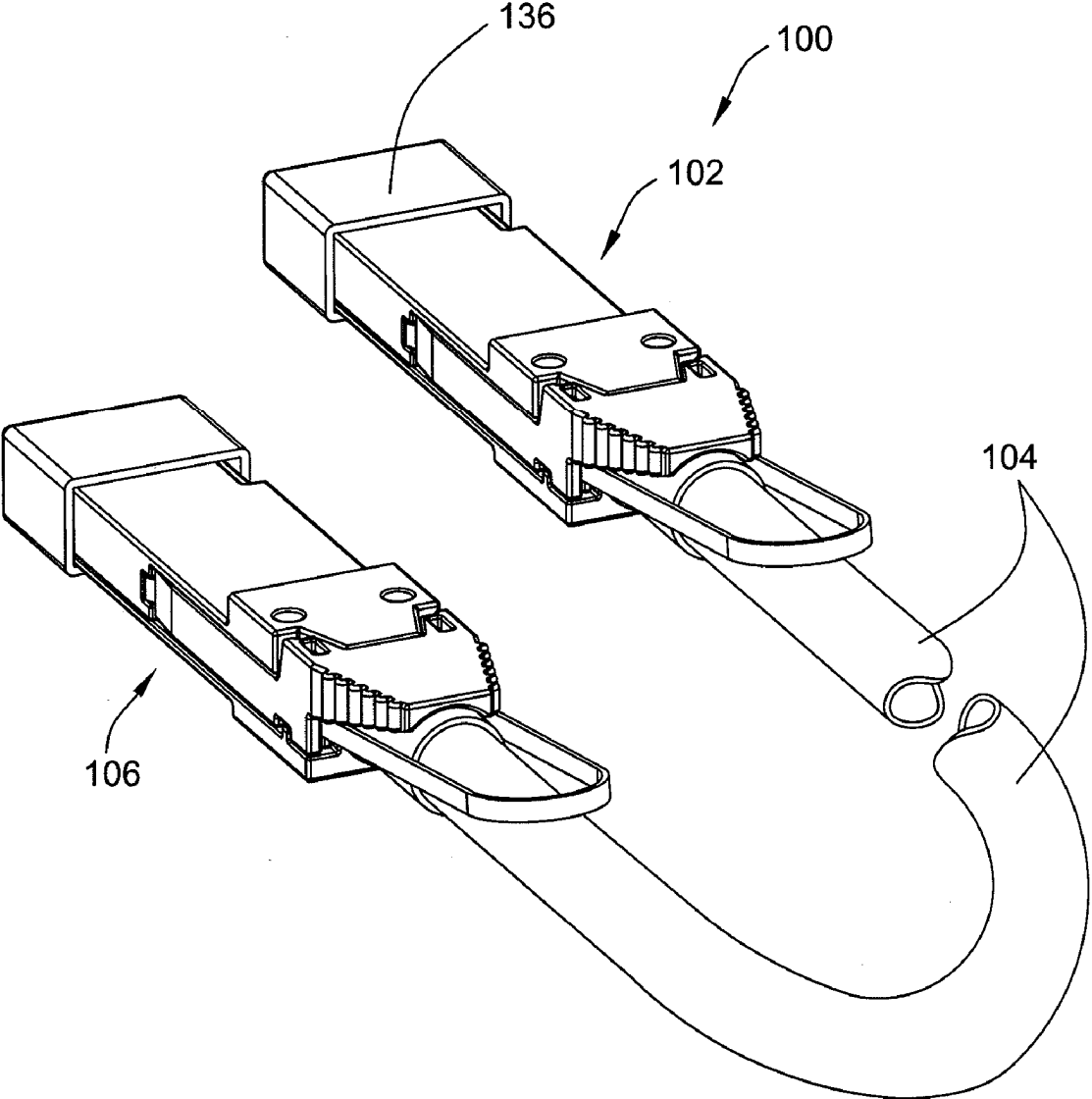

FIG. 2

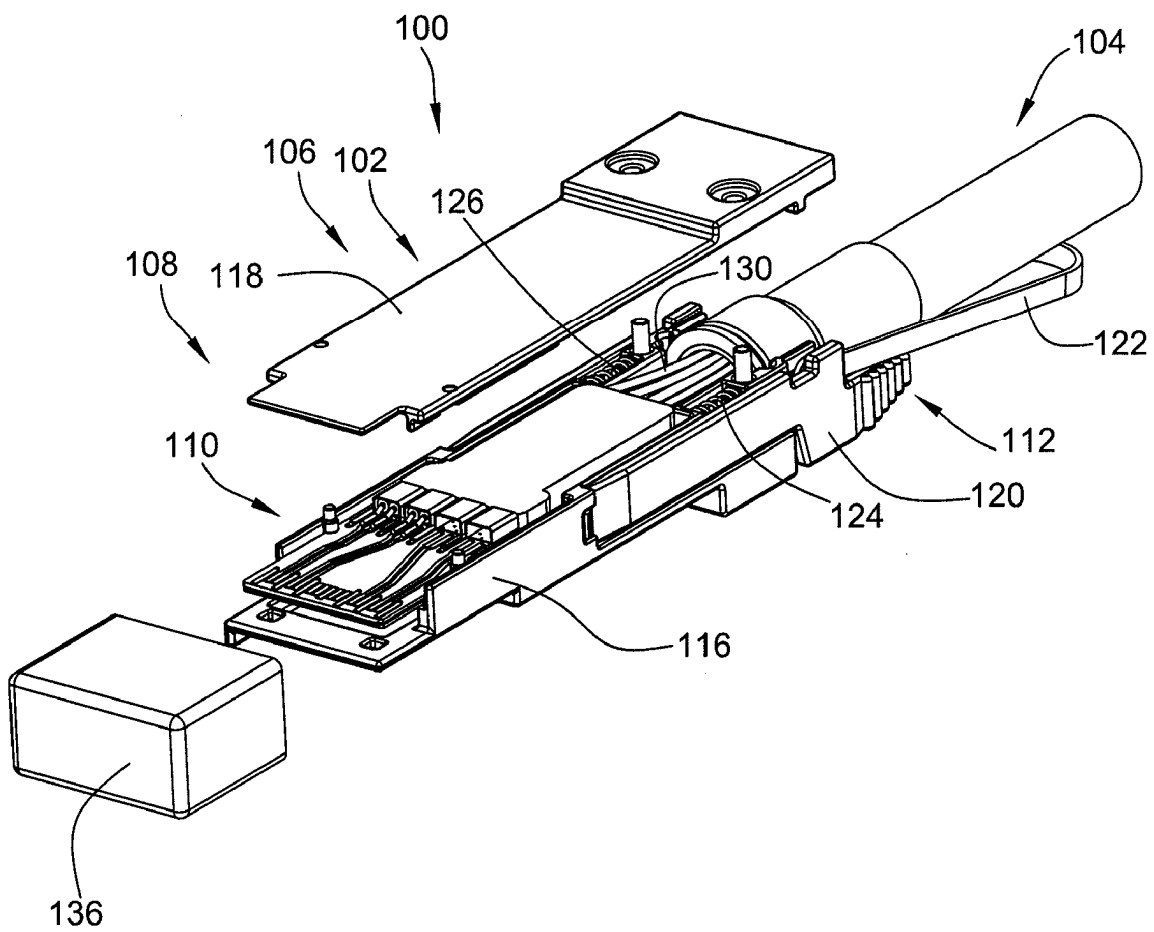

FIG. 3

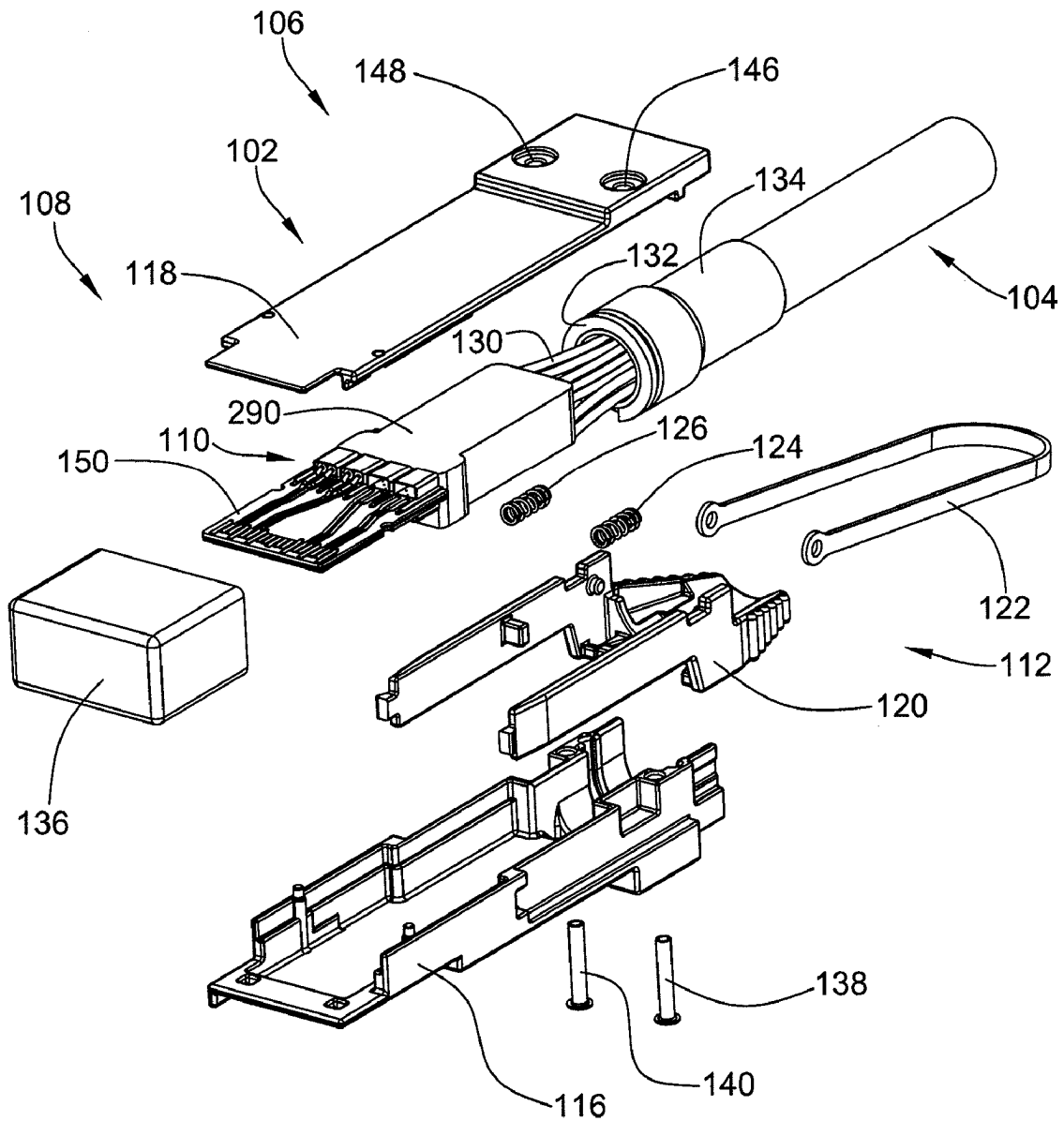
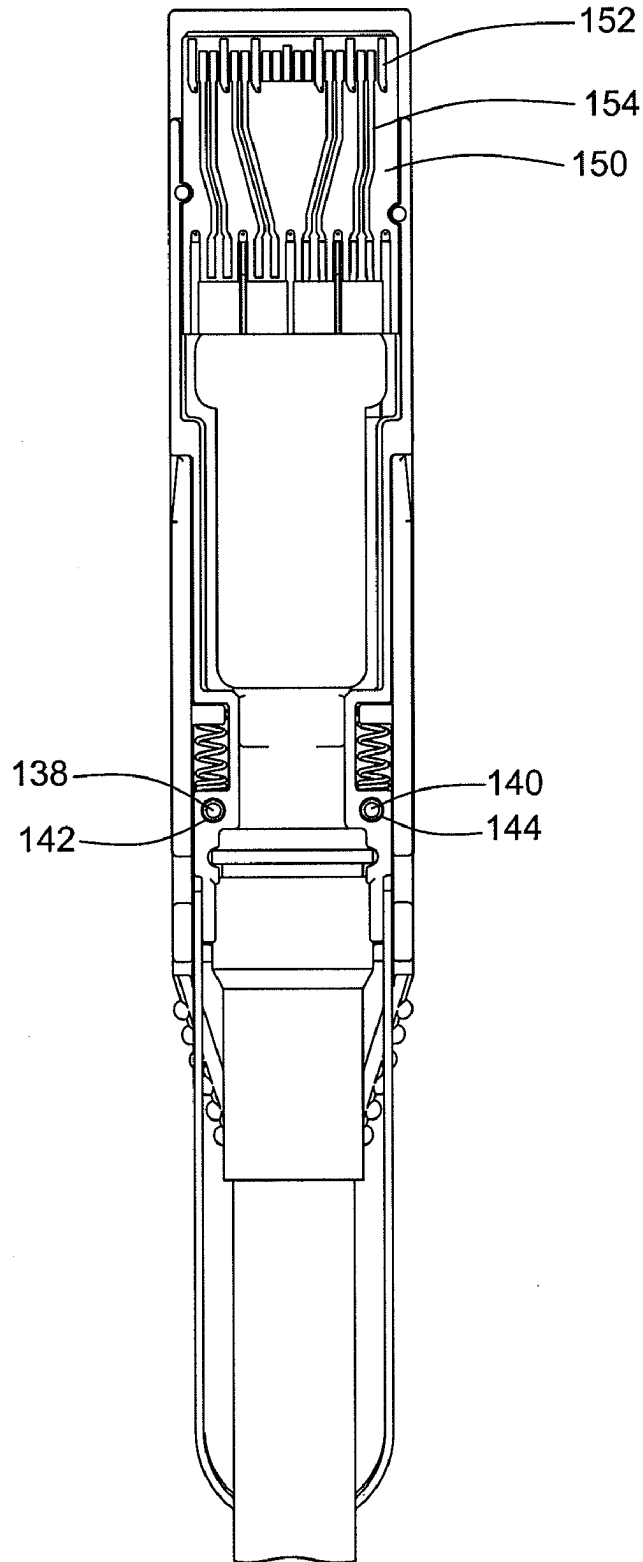

FIG. 4



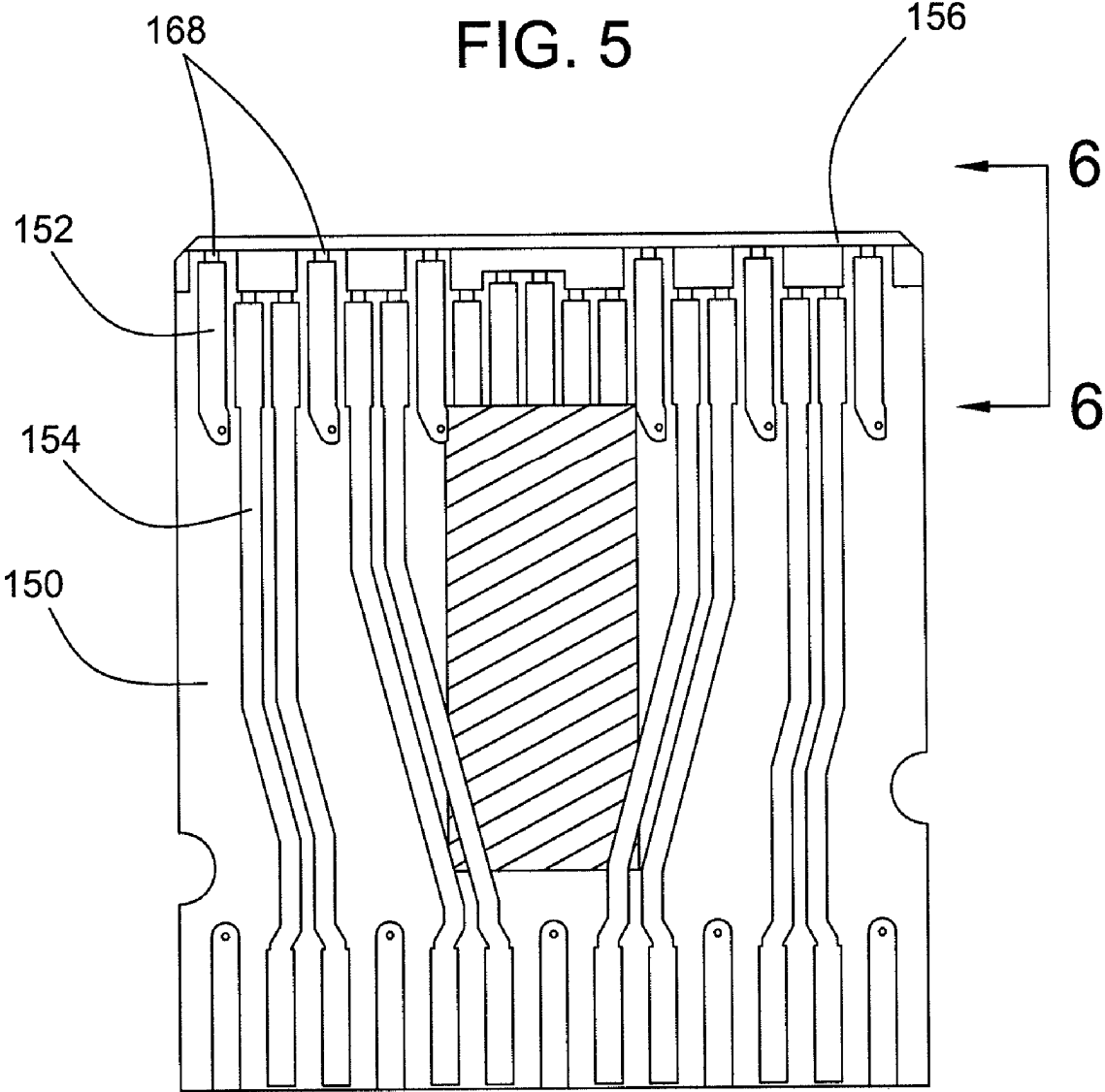

FIG. 6

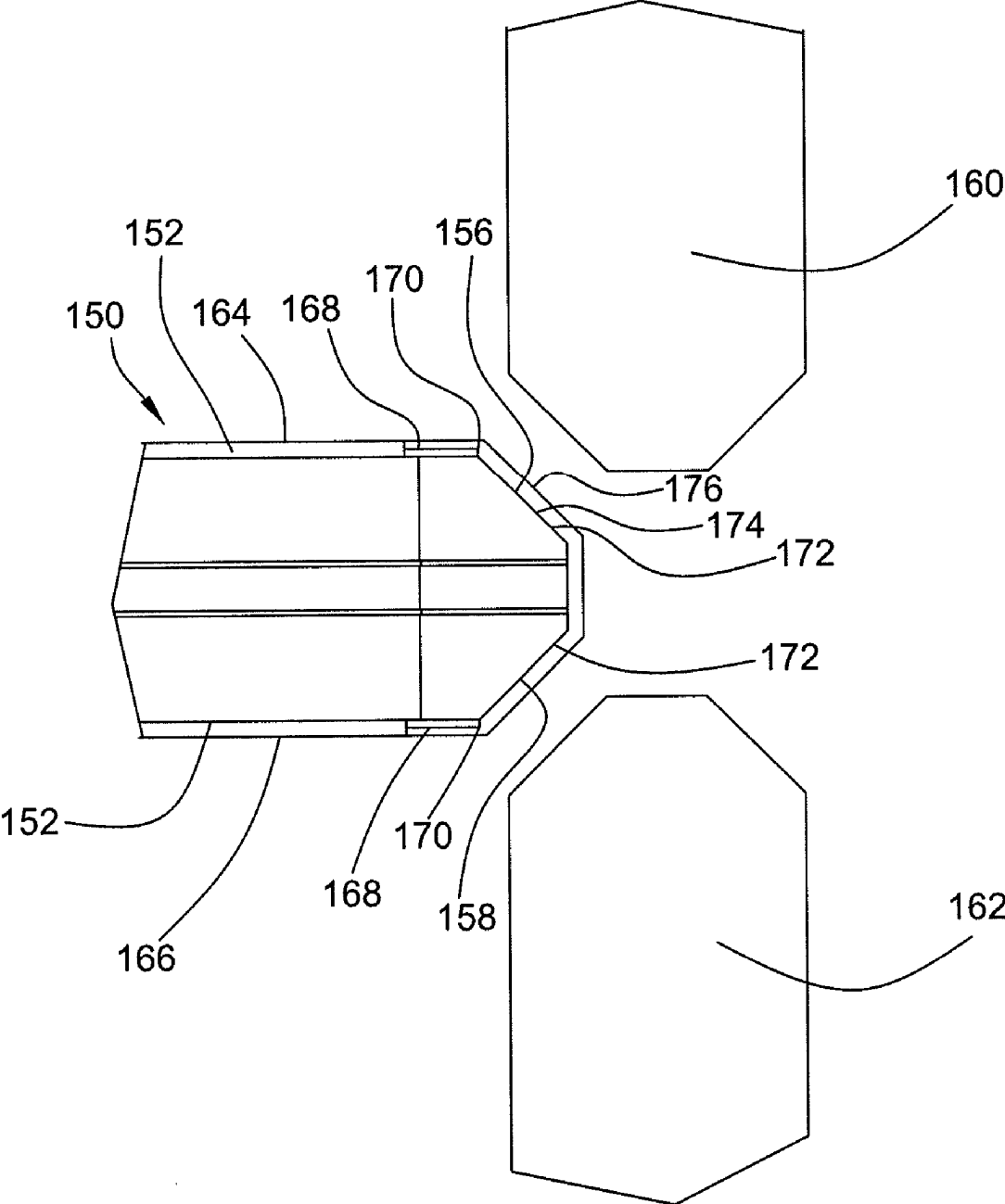

FIG. 7

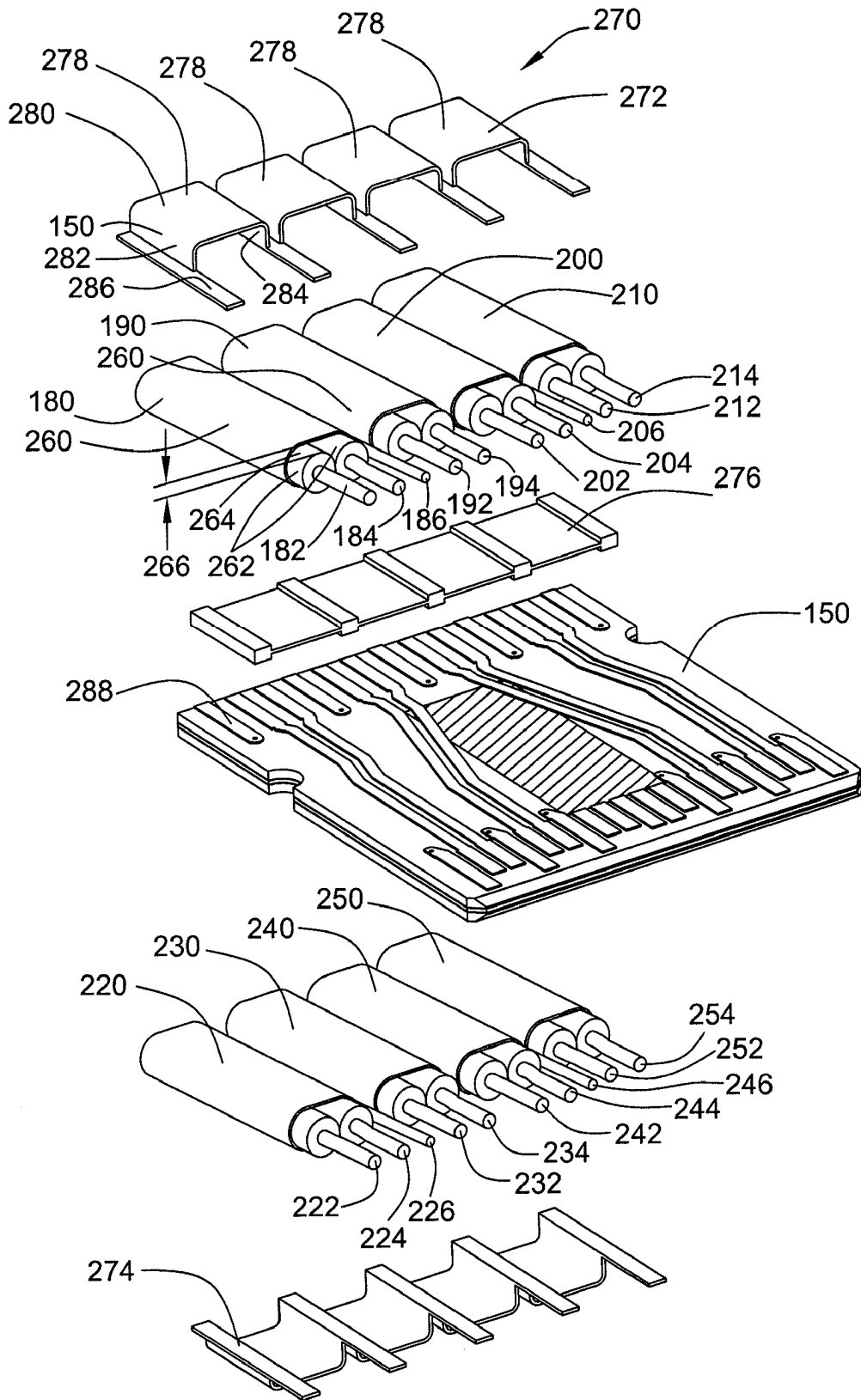

FIG. 8

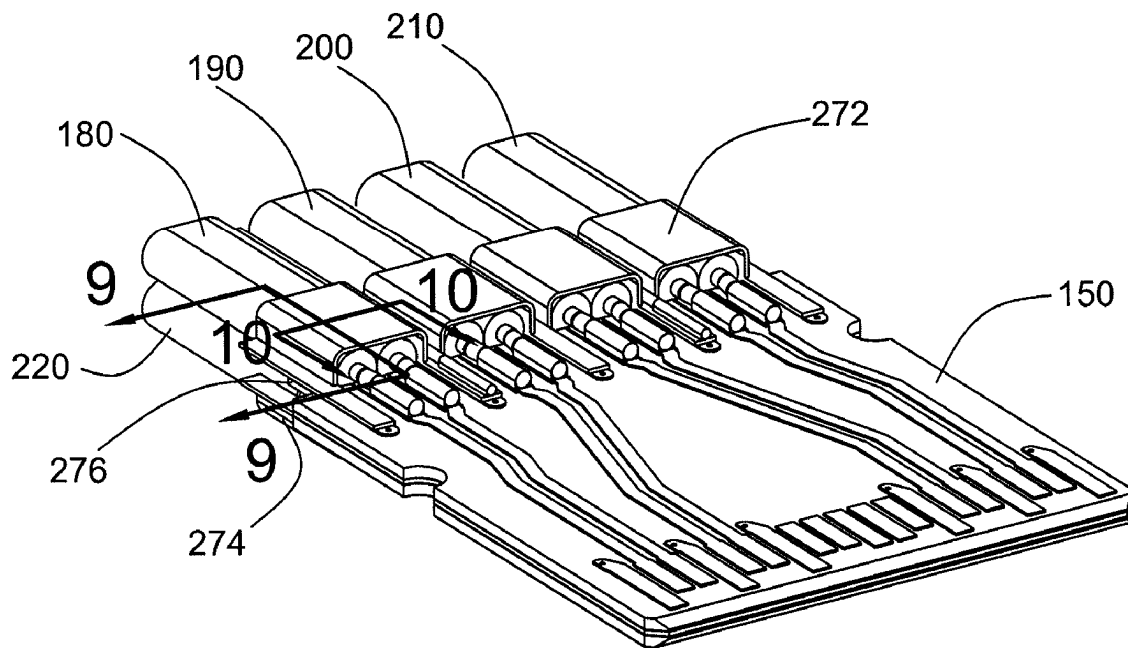



FIG. 10

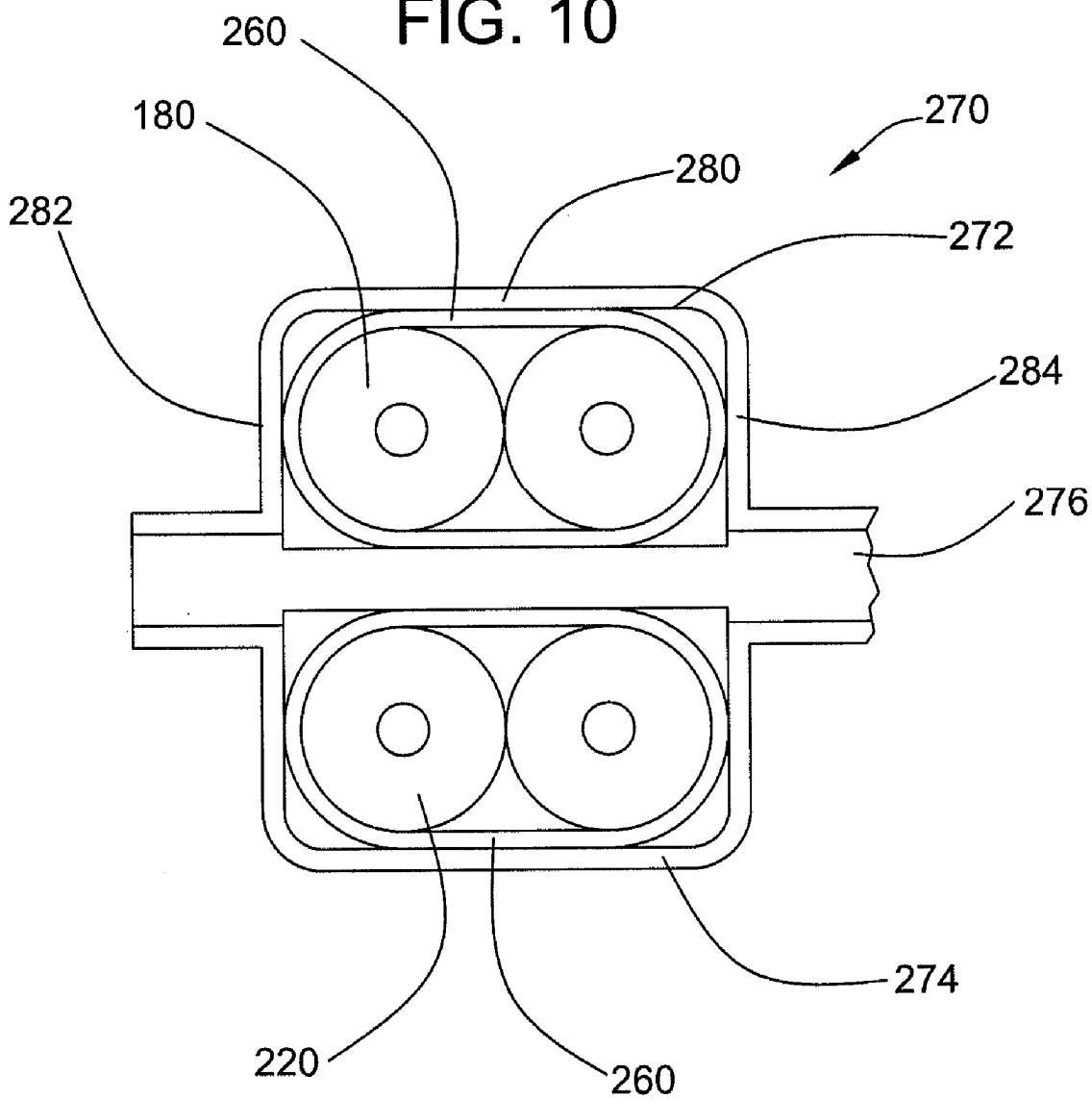

FIG. 11

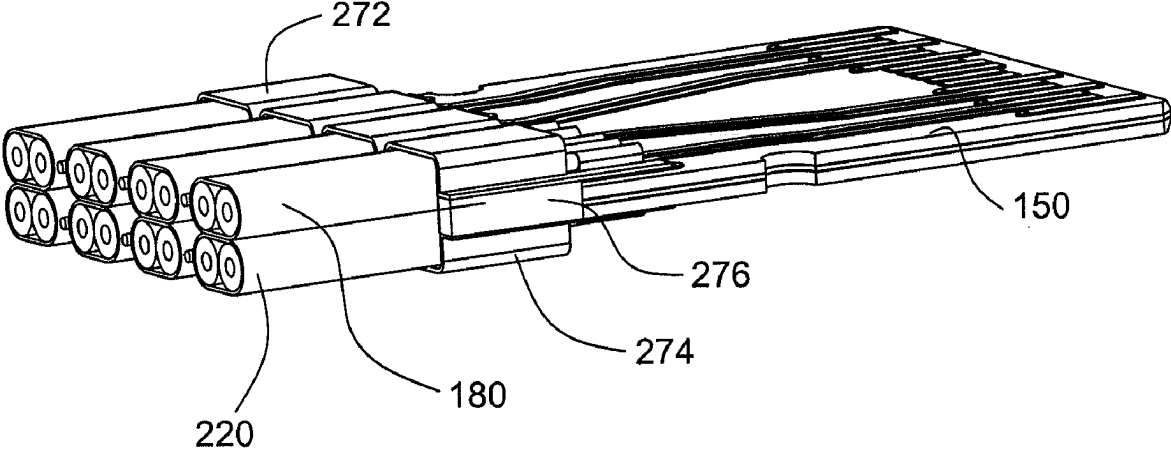

FIG. 12

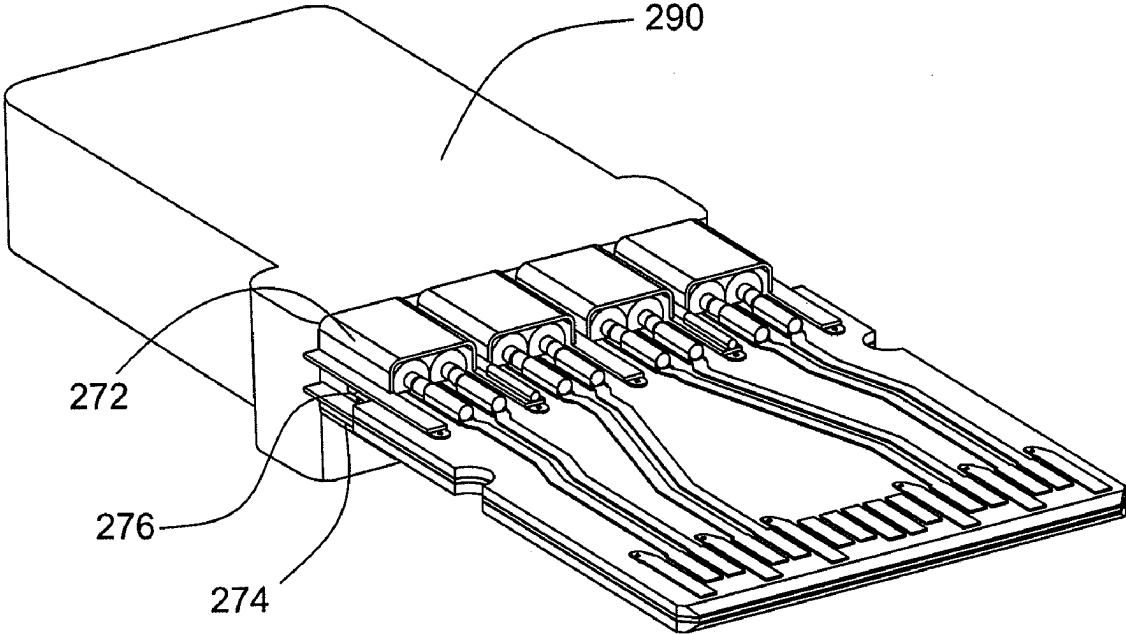

FIG. 13

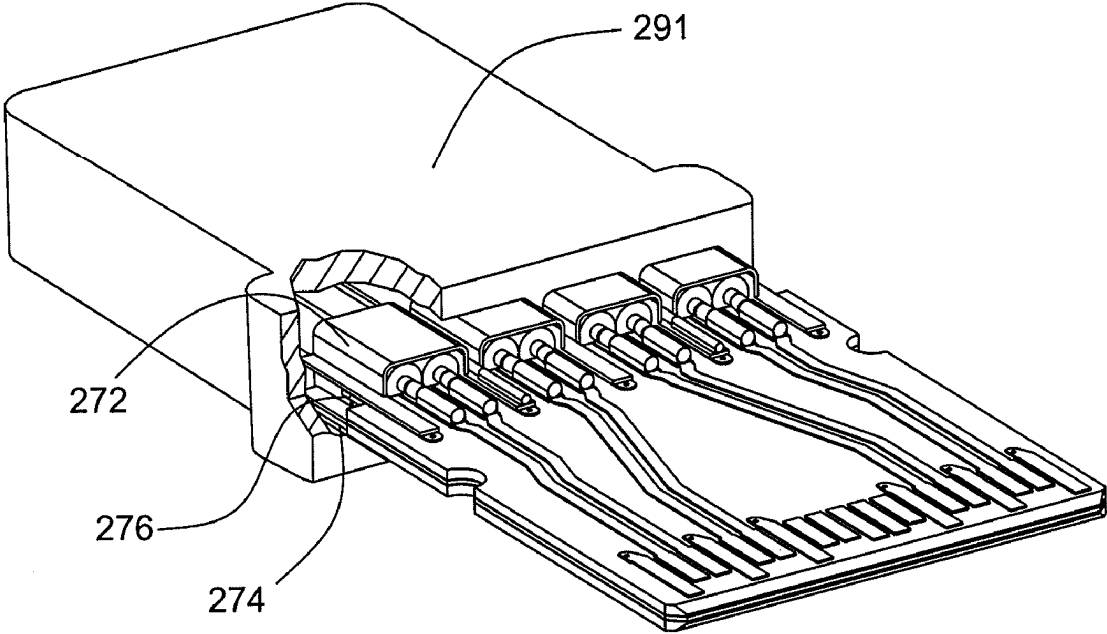

FIG. 14

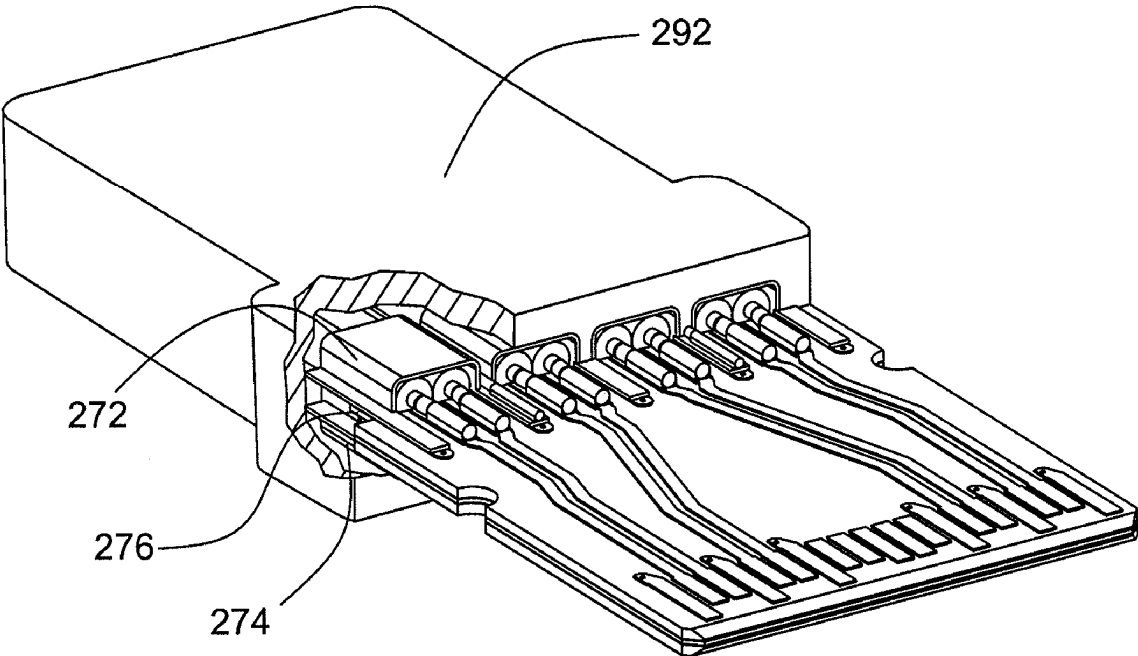

FIG. 15

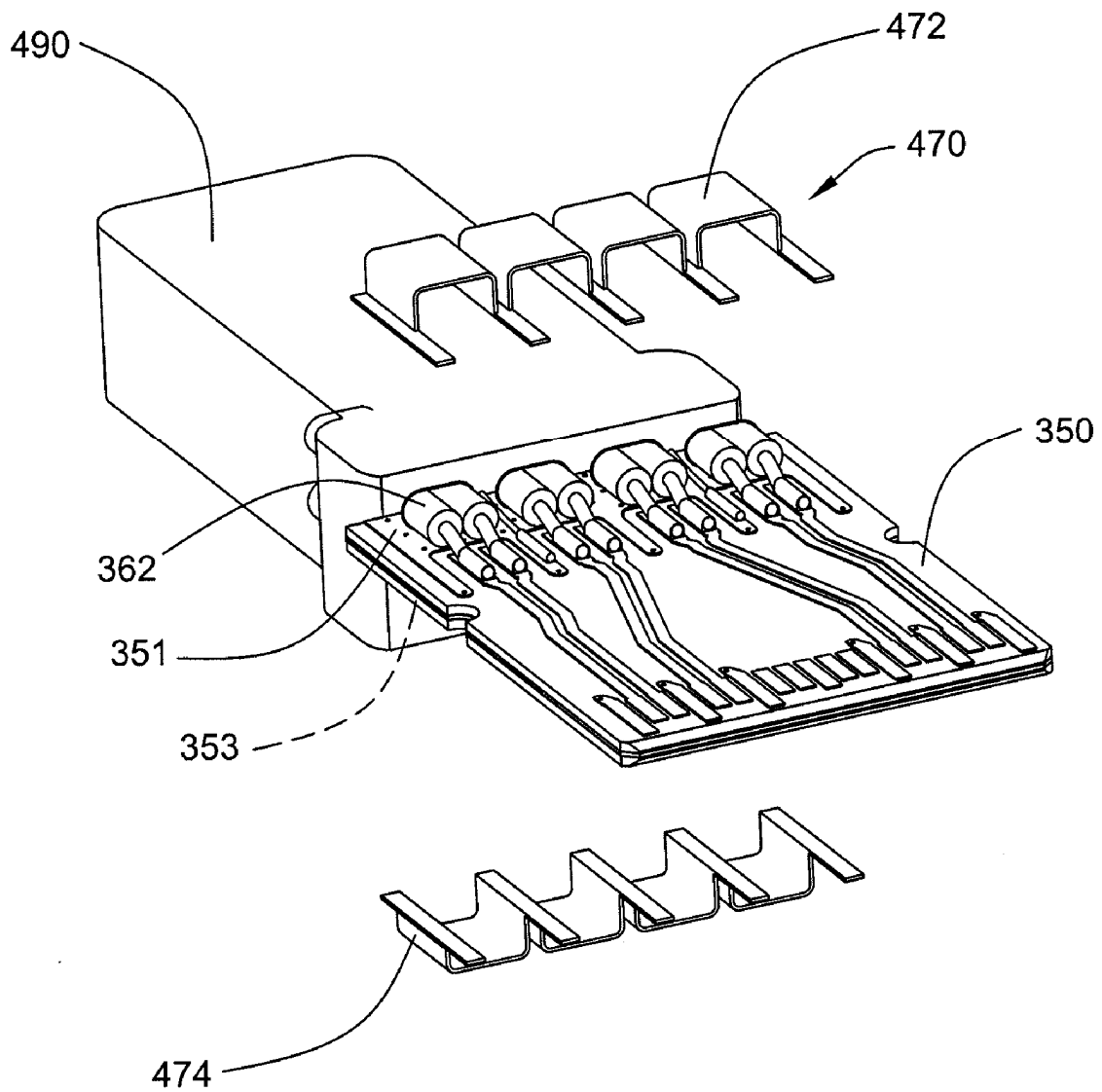

FIG. 16

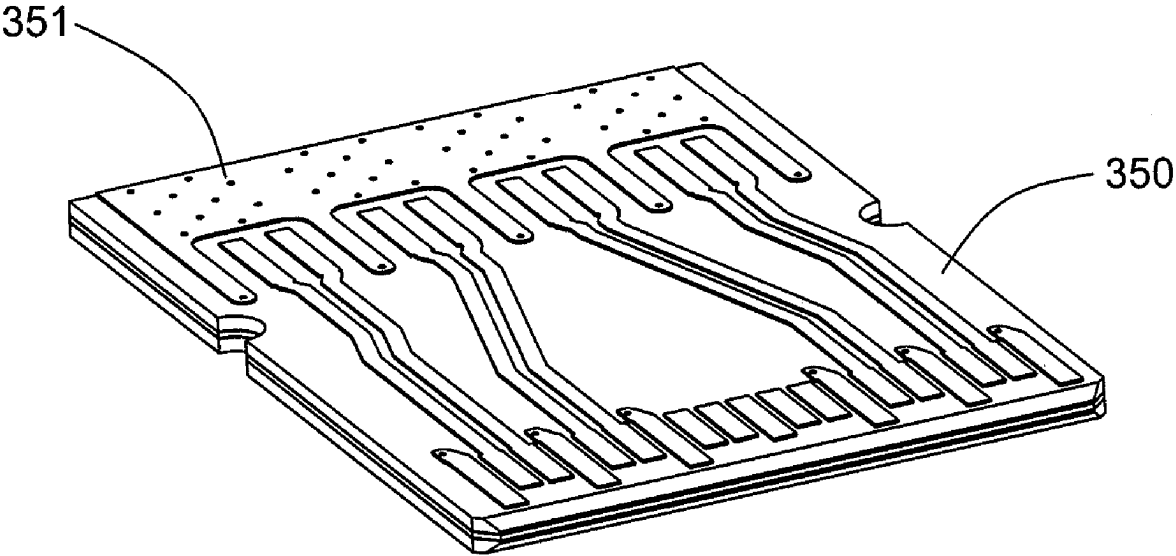

FIG. 17

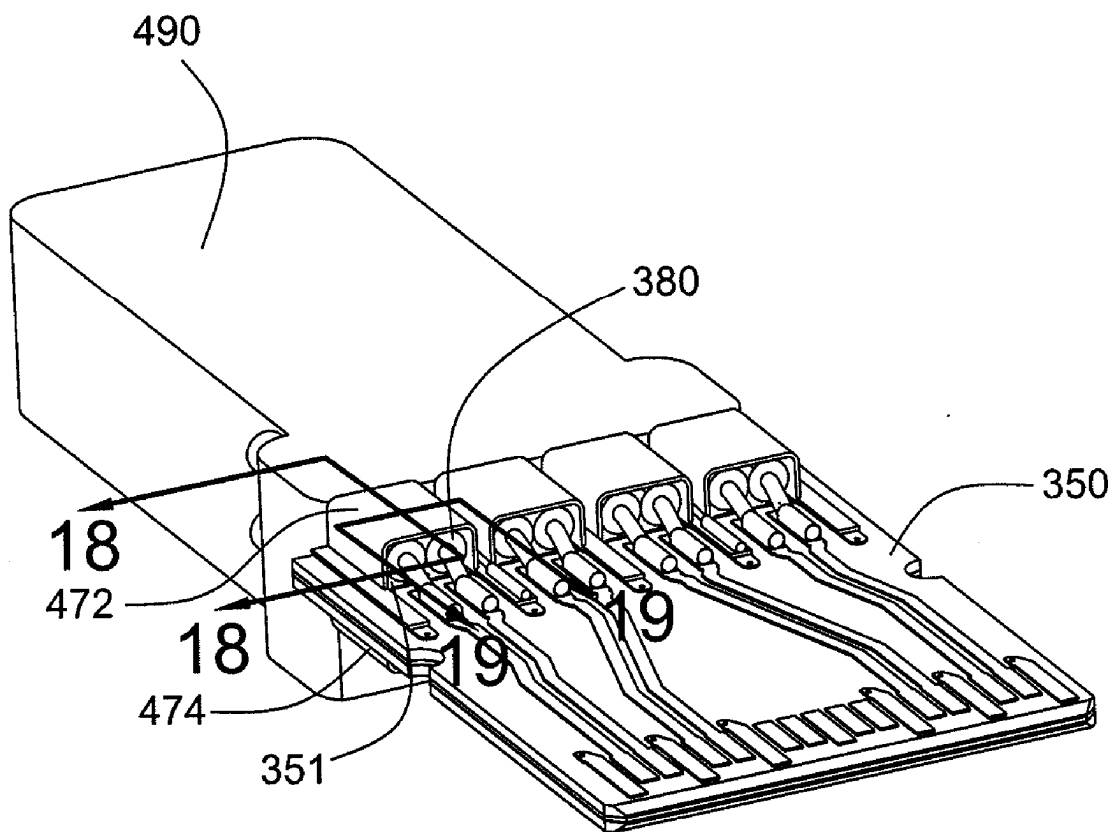
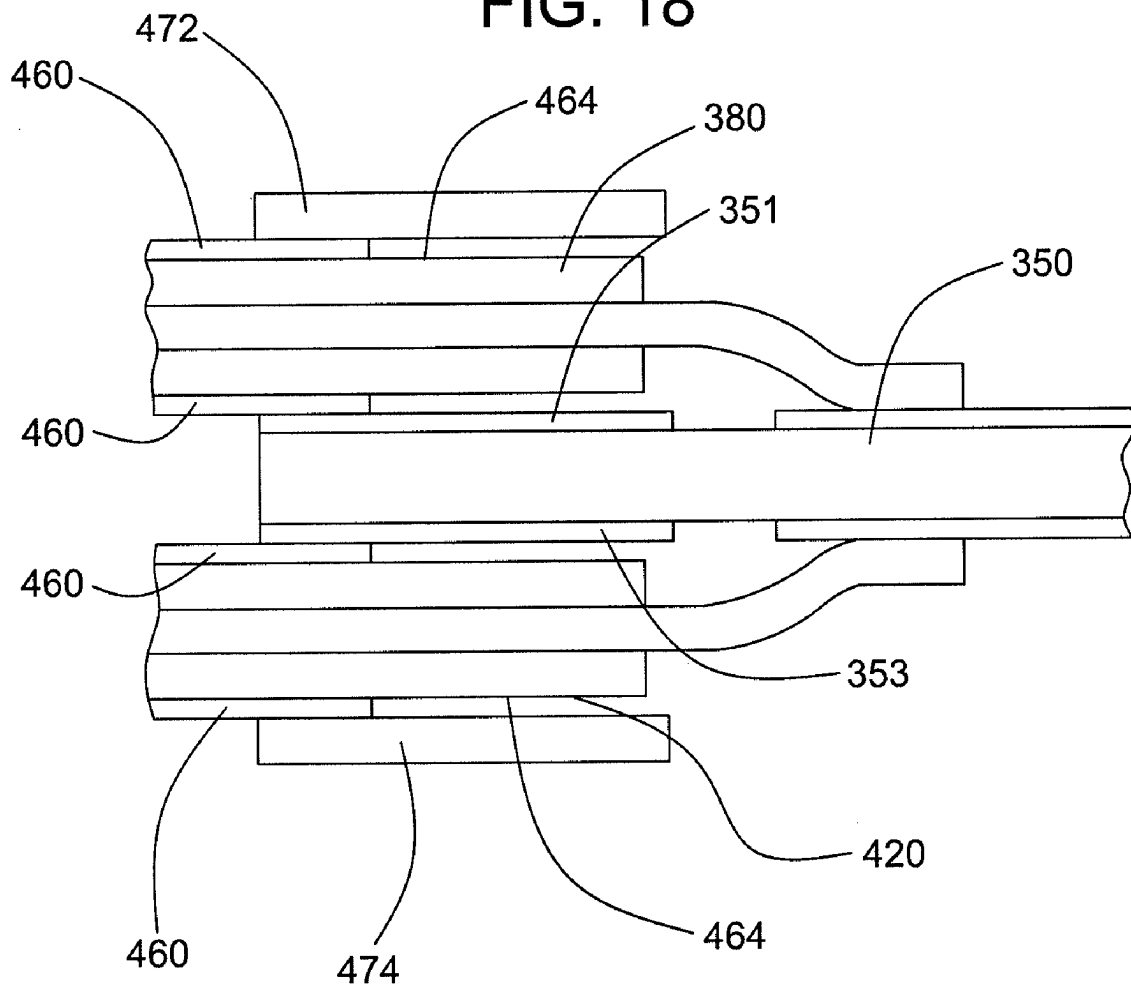

FIG. 18



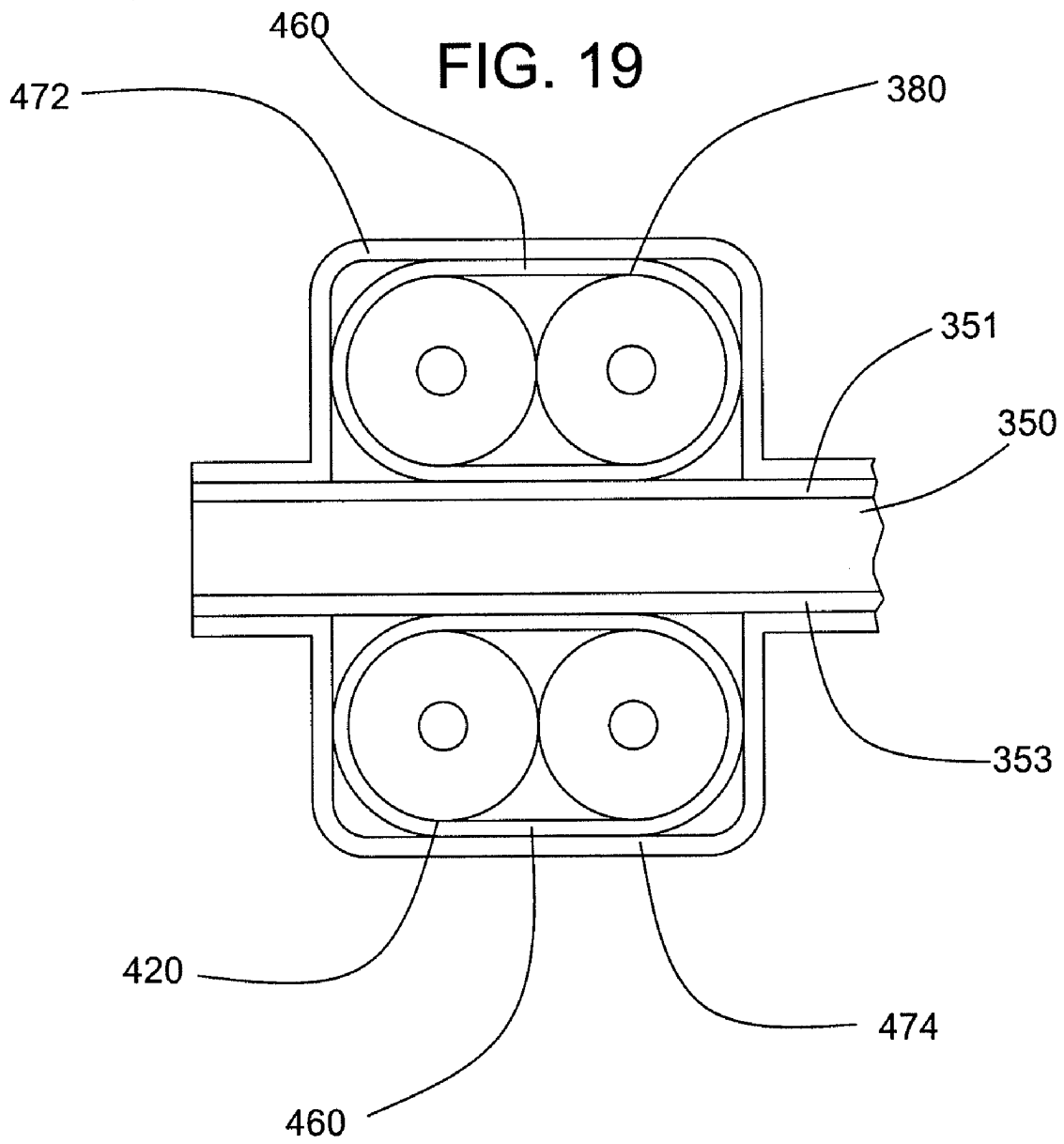

FIG. 20

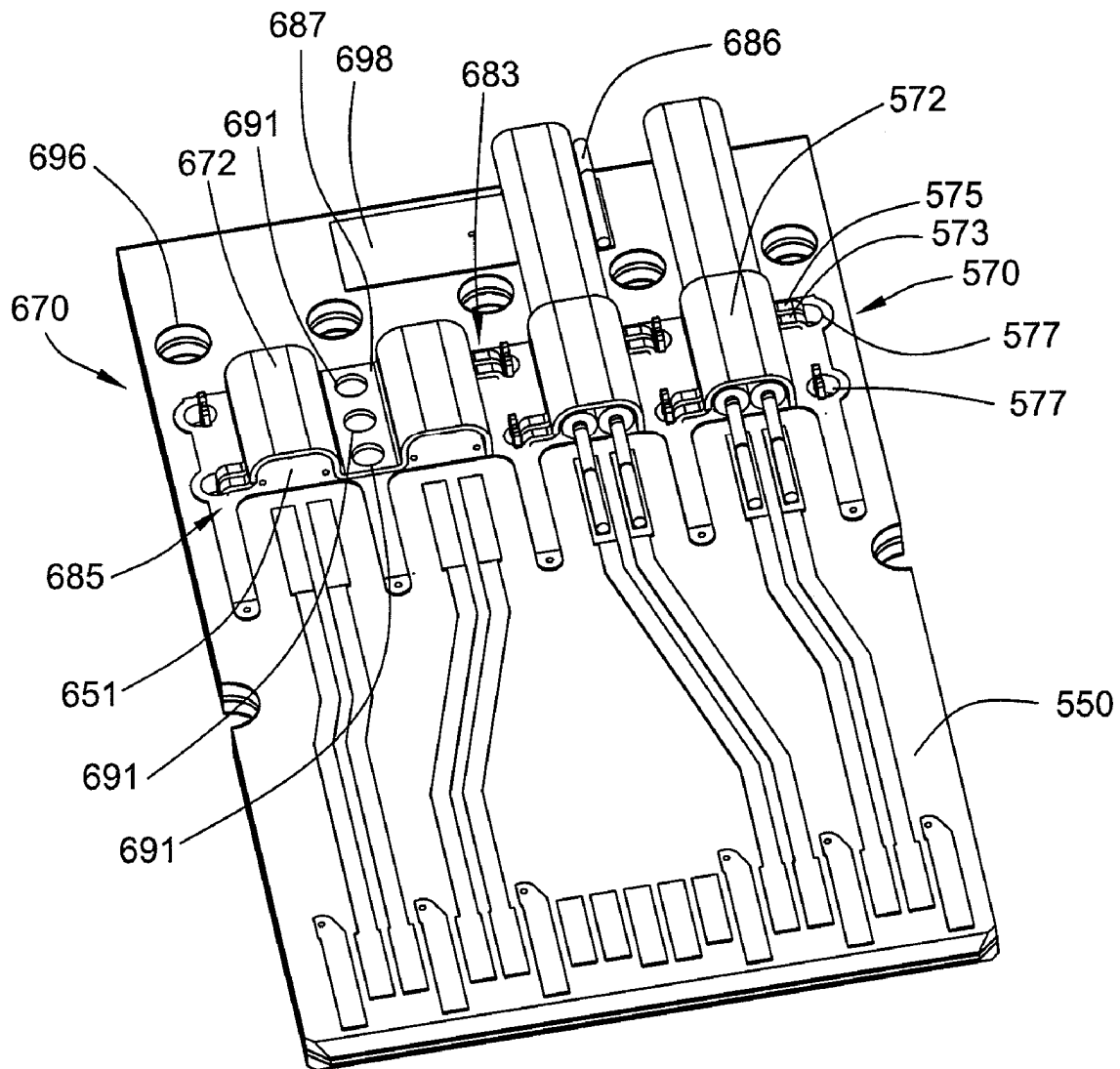

FIG. 21

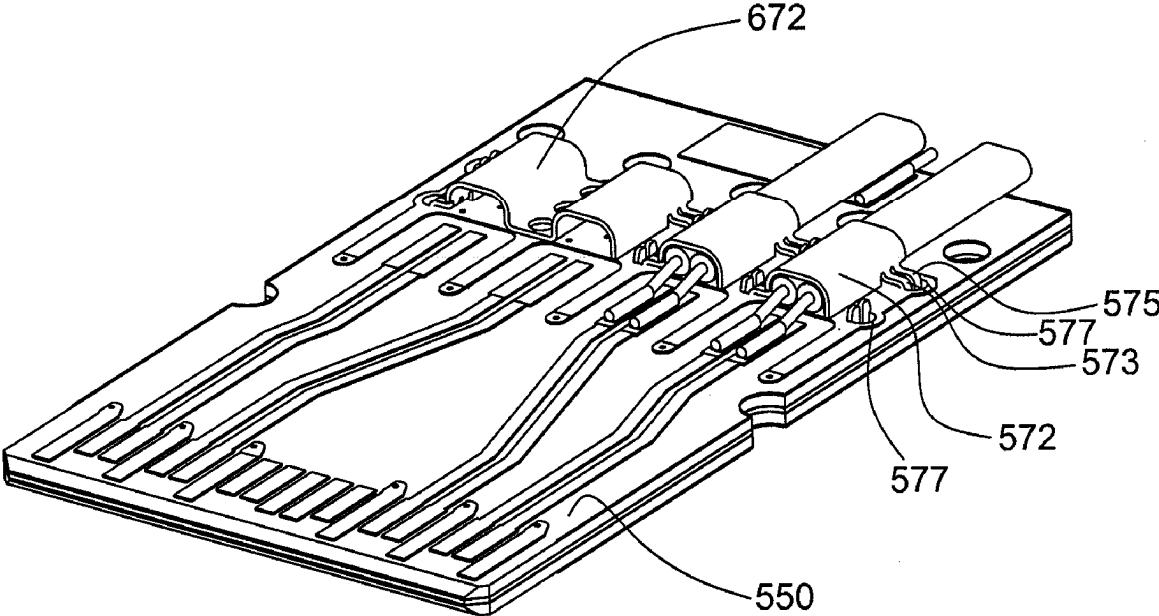

FIG. 22

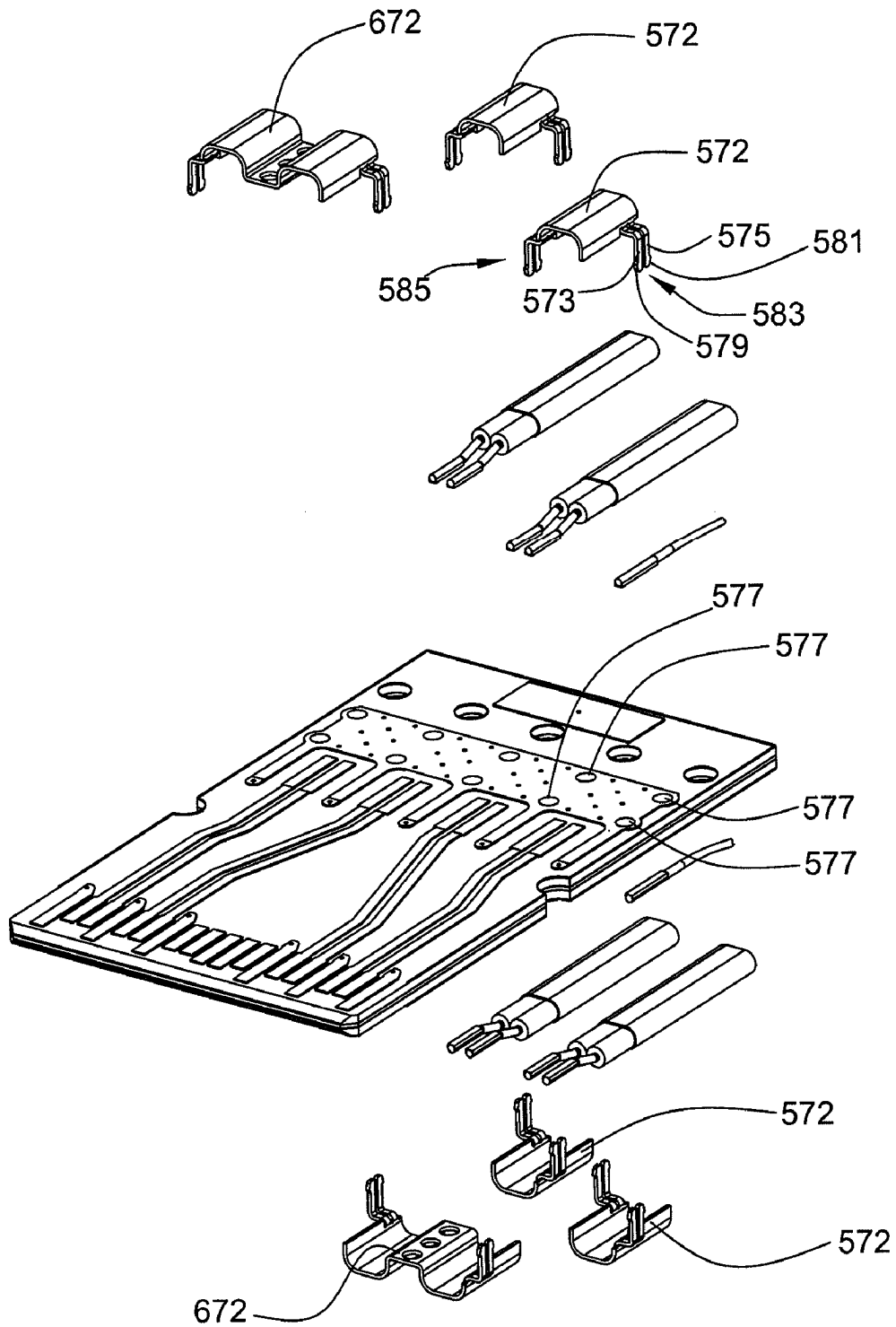

FIG. 23

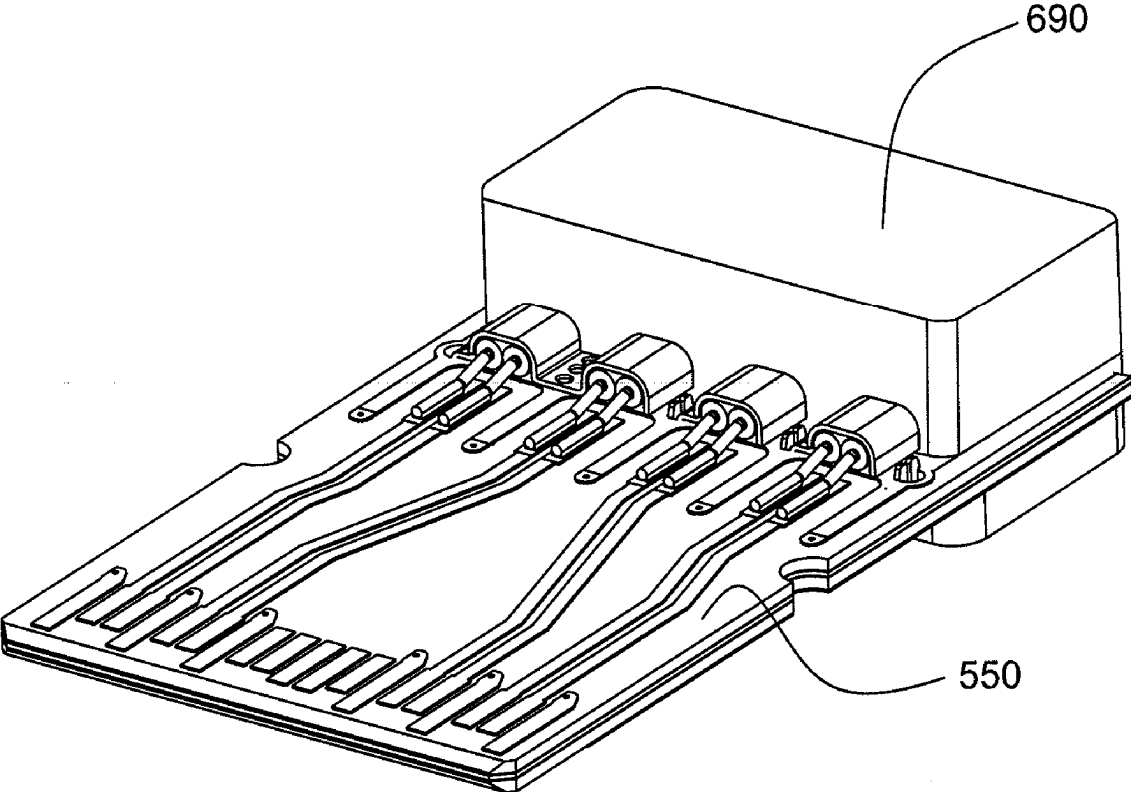

FIG. 24

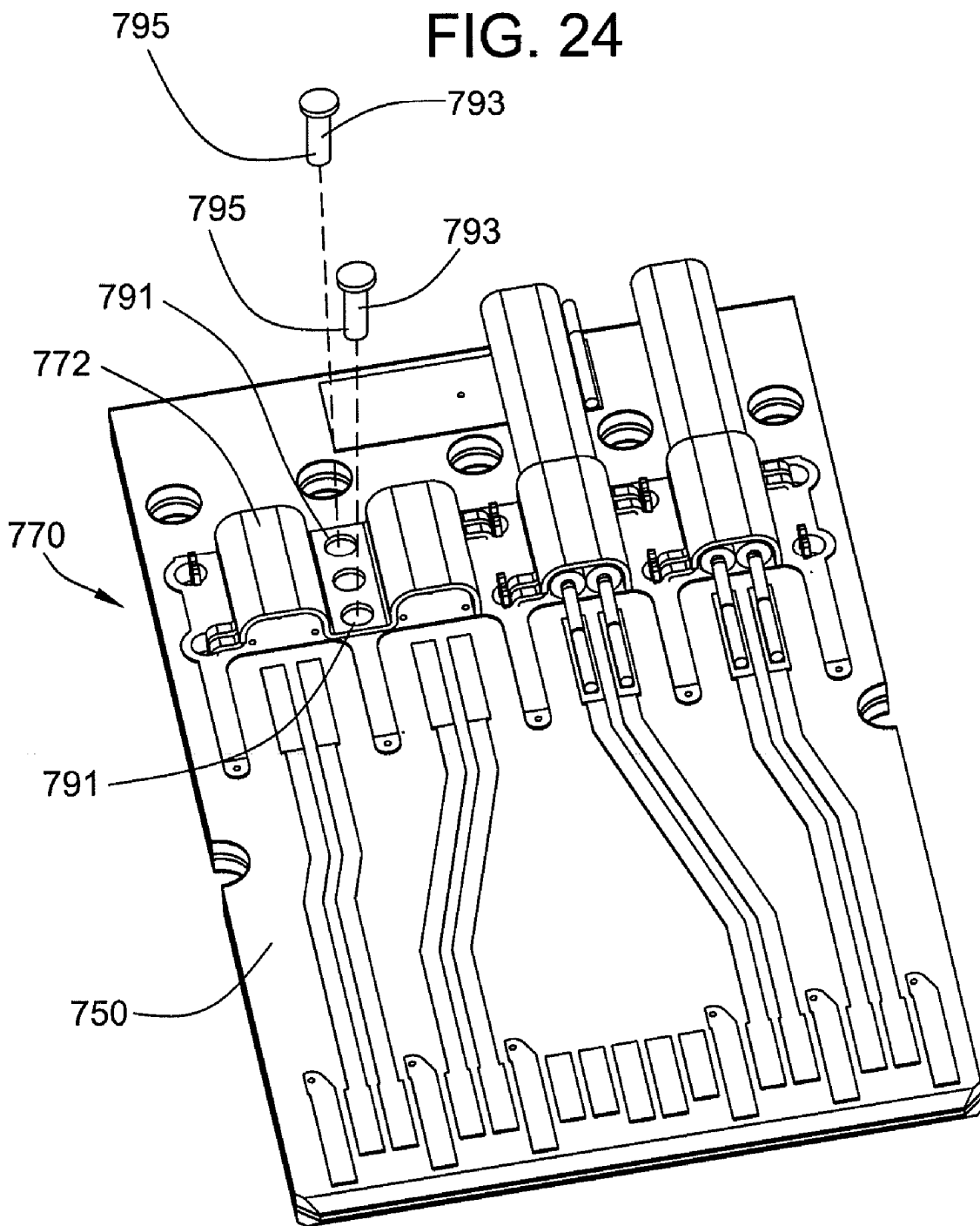

FIG. 25

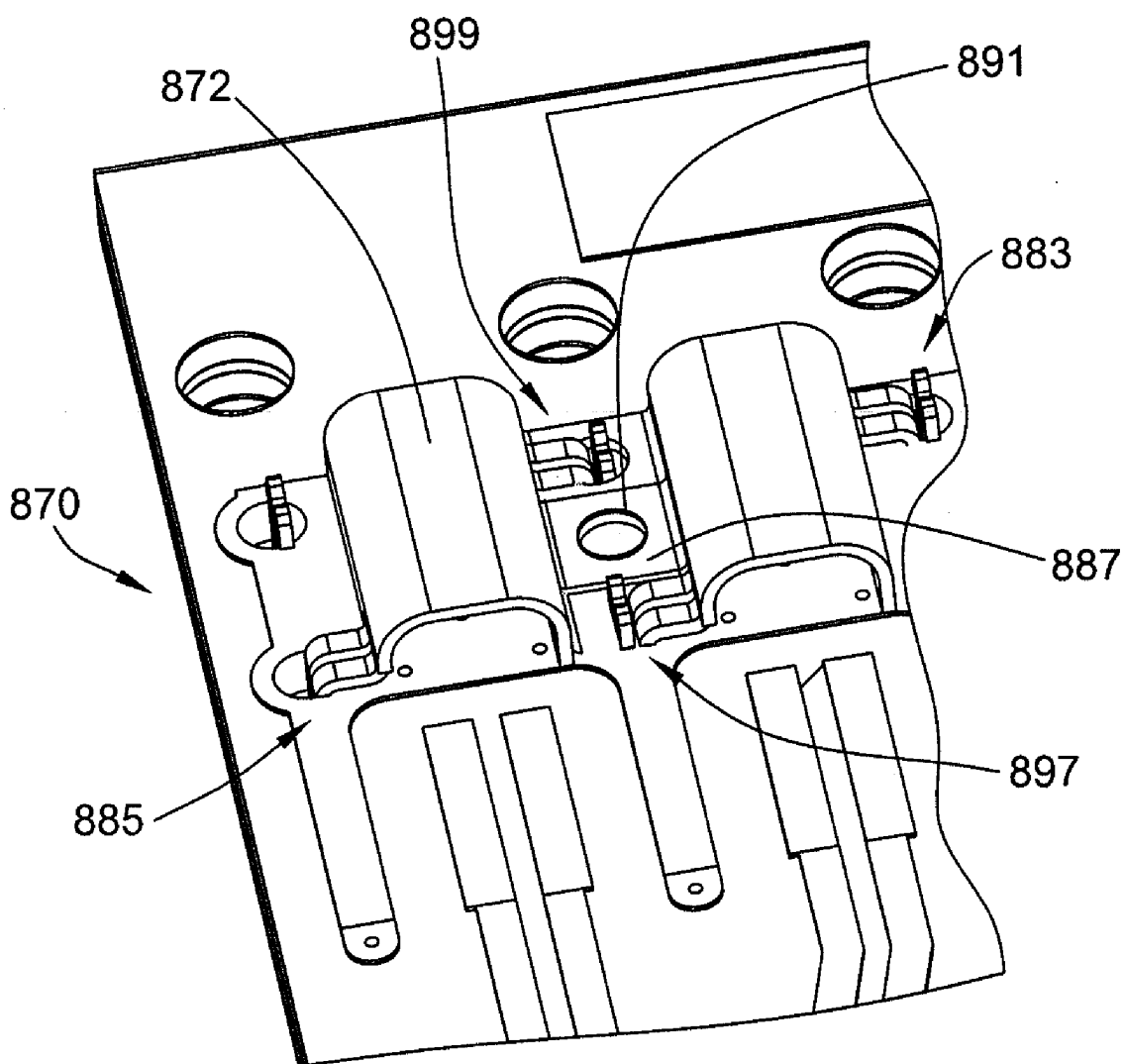

FIG. 26

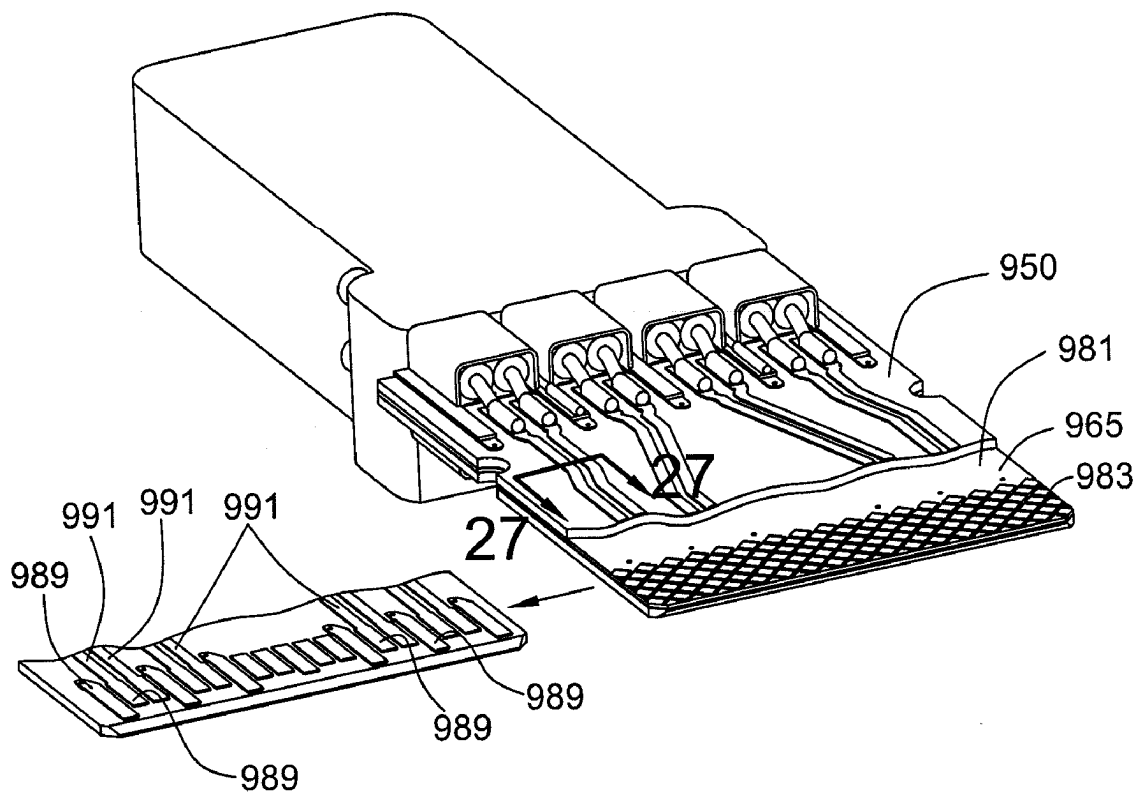

FIG. 27

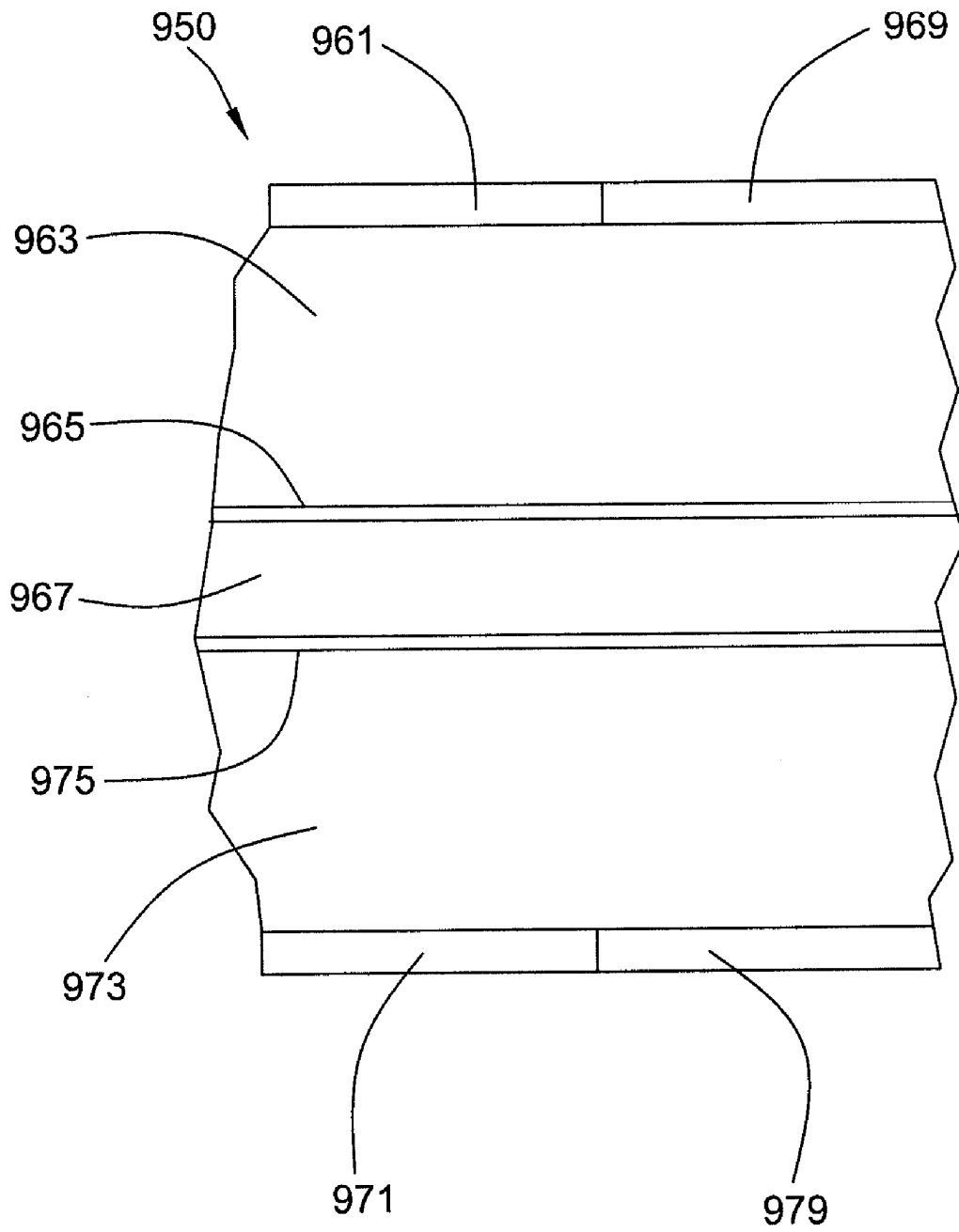

FIG. 28

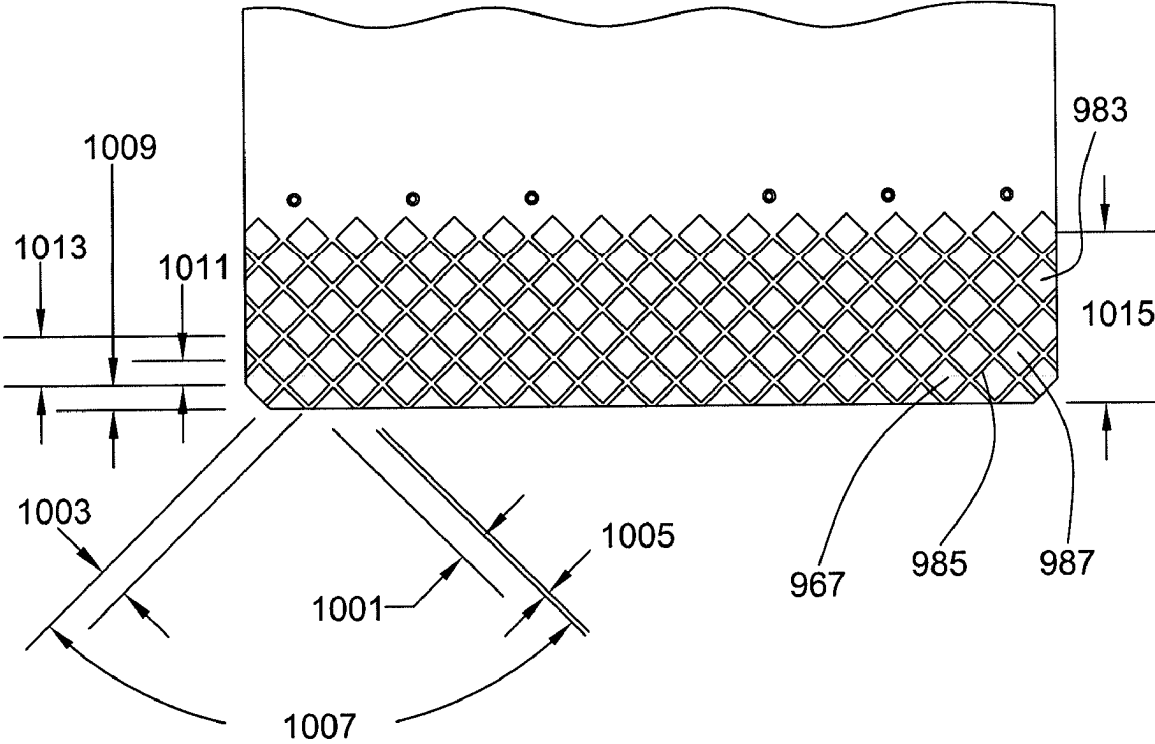

FIG. 29

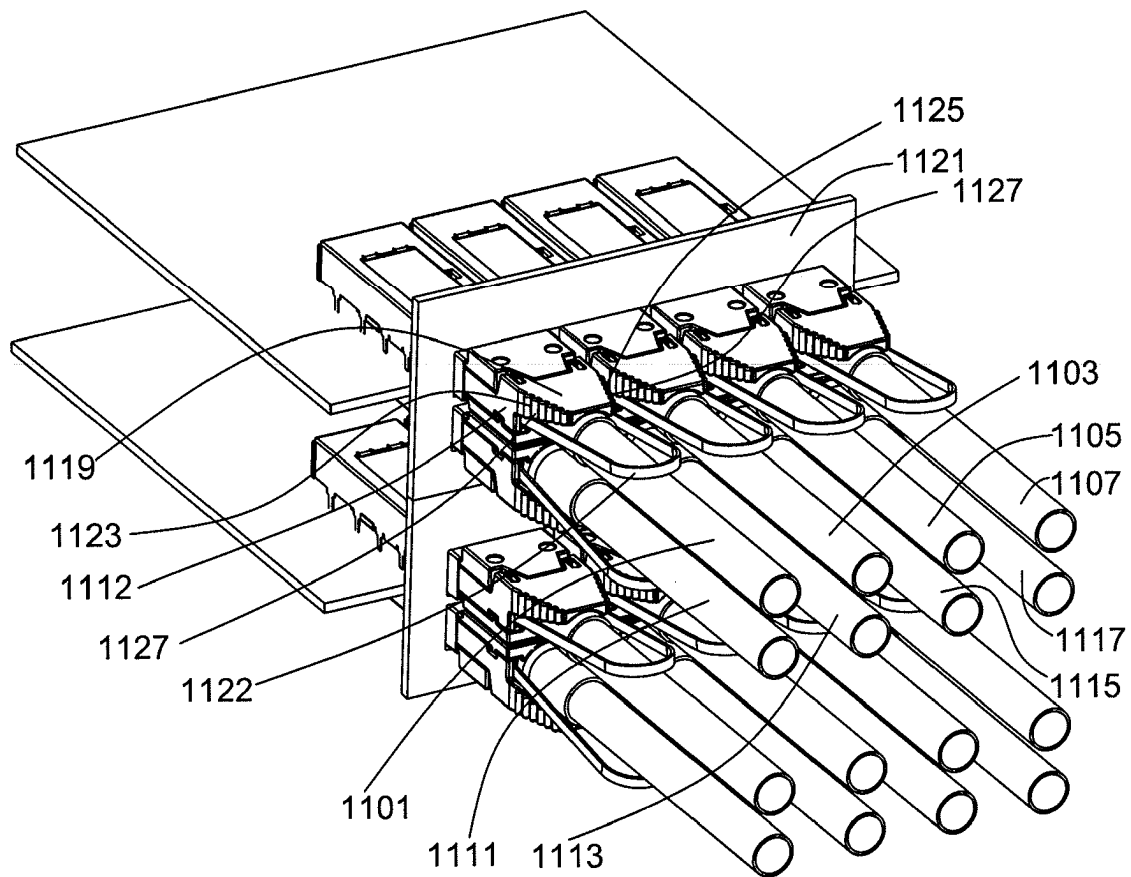

FIG. 30

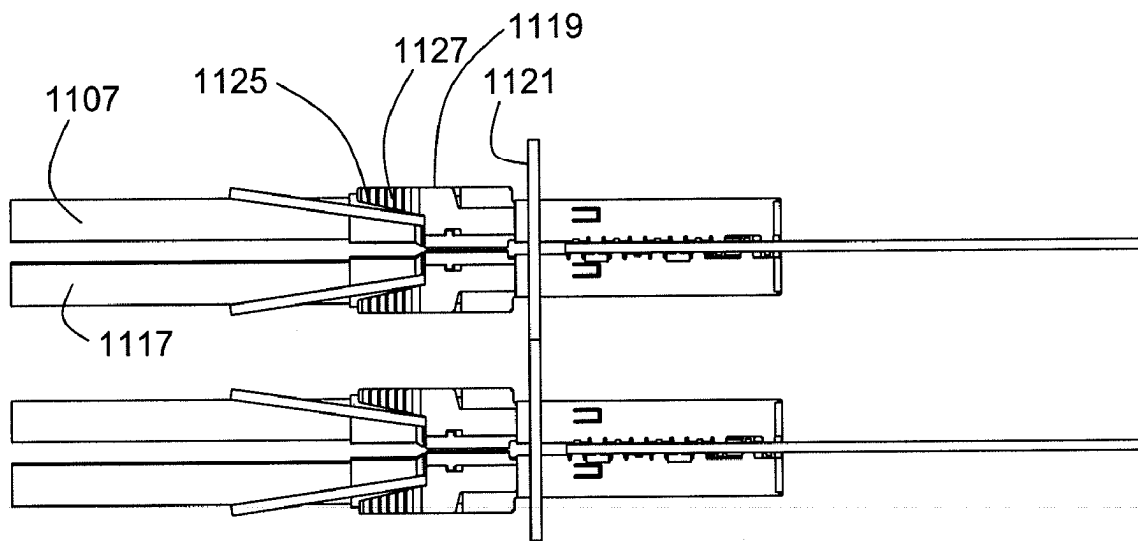

FIG. 31

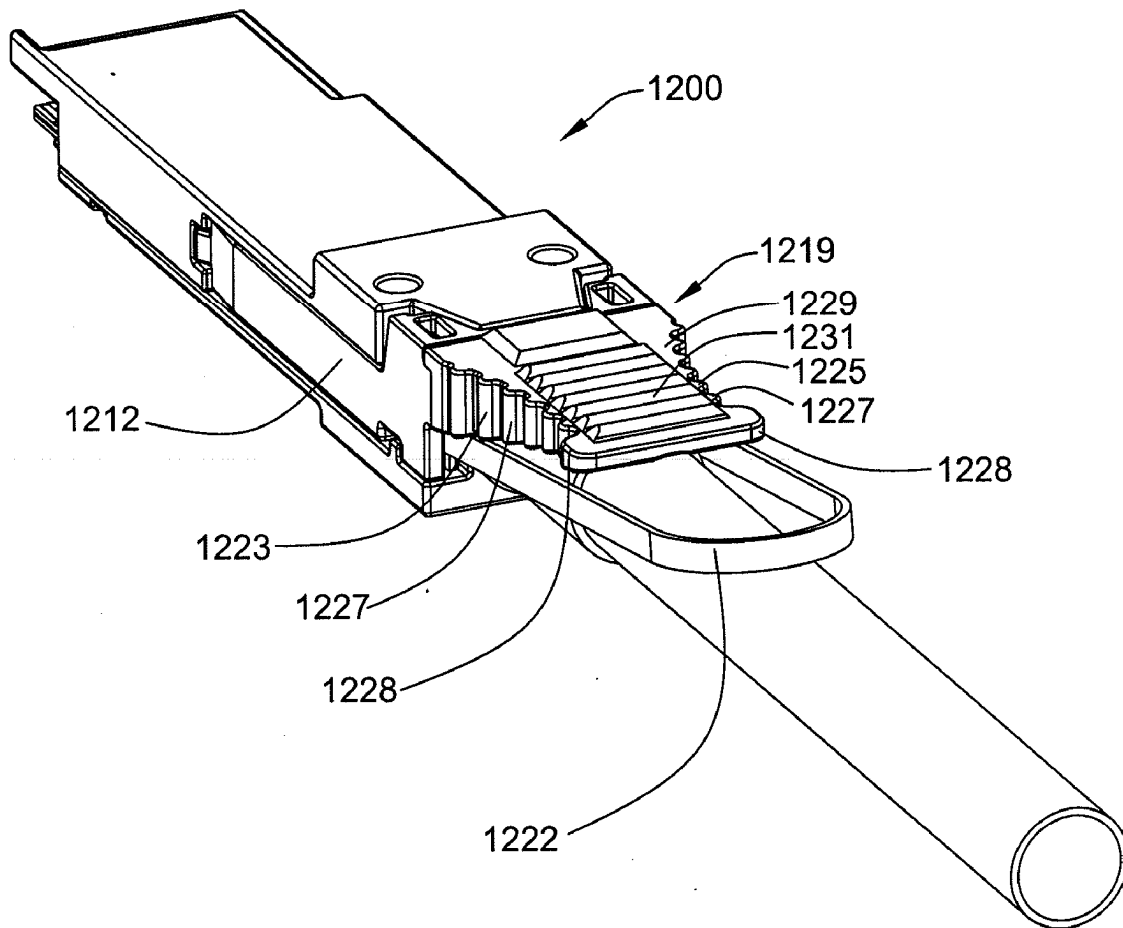

FIG. 32

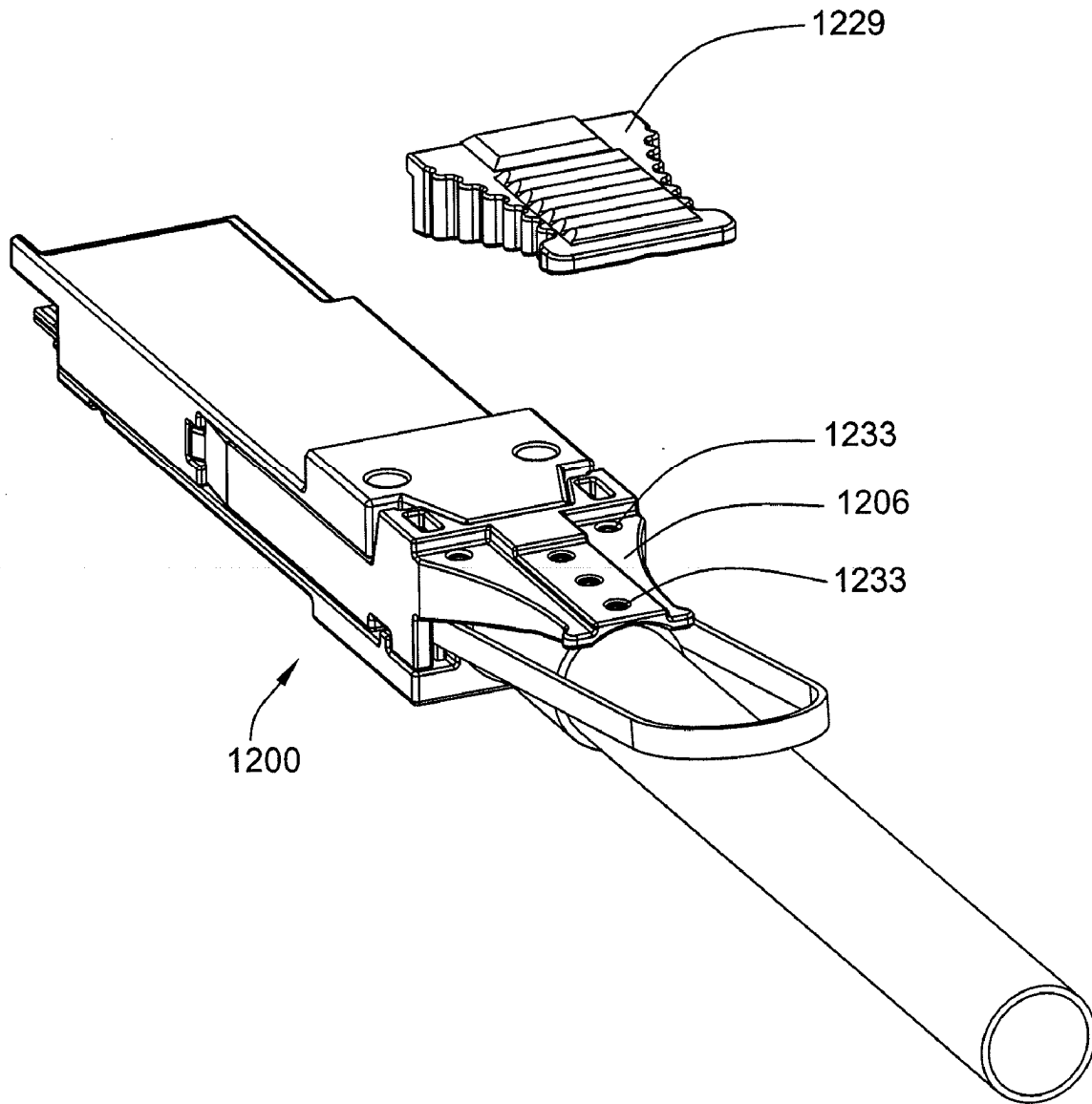

FIG. 33

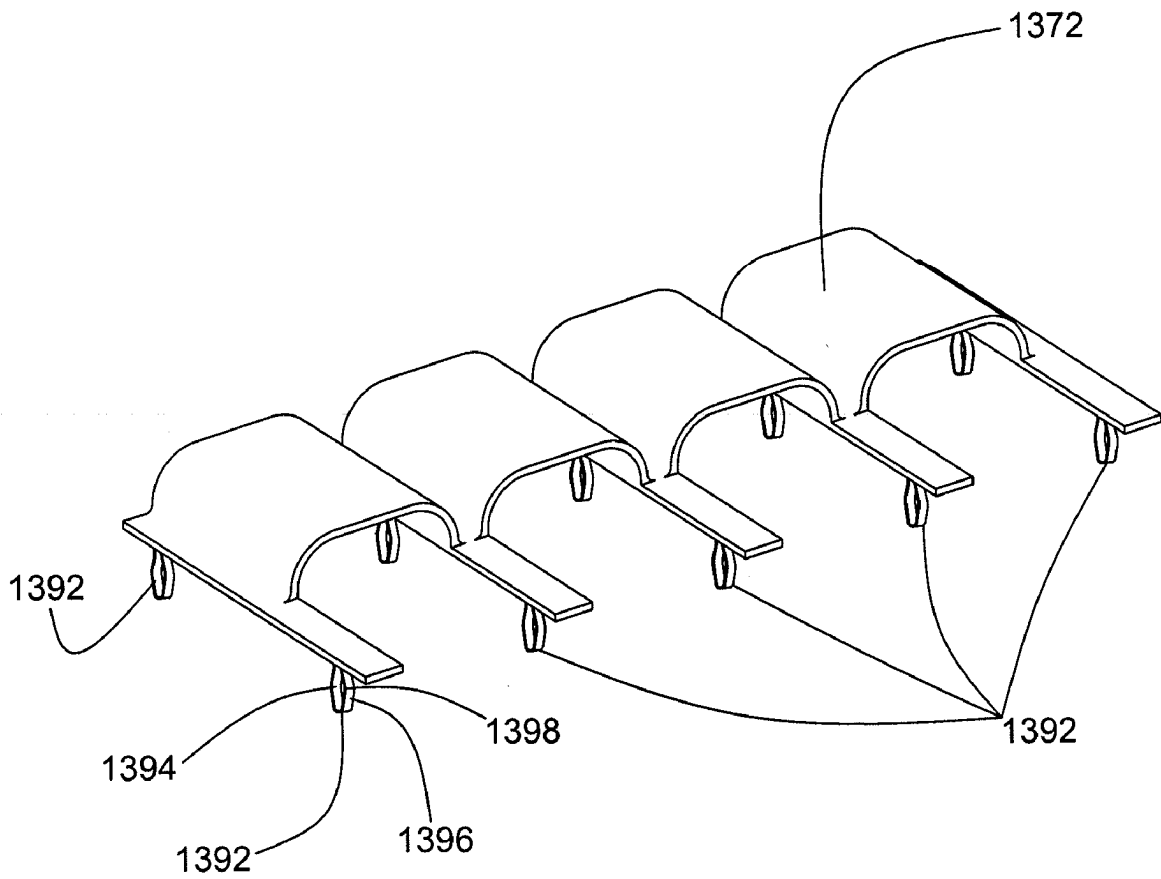

FIG. 34

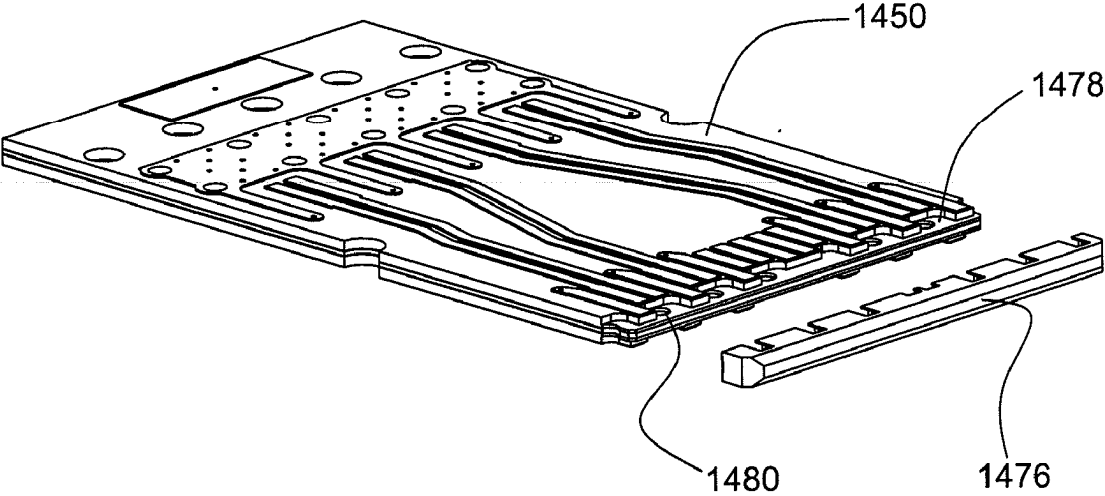

FIG. 35

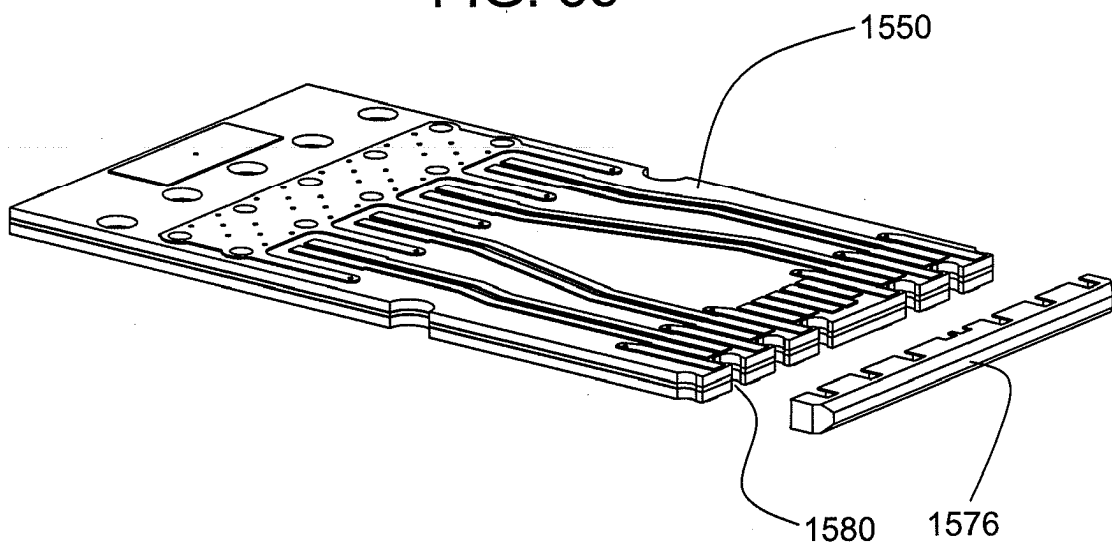

FIG. 36

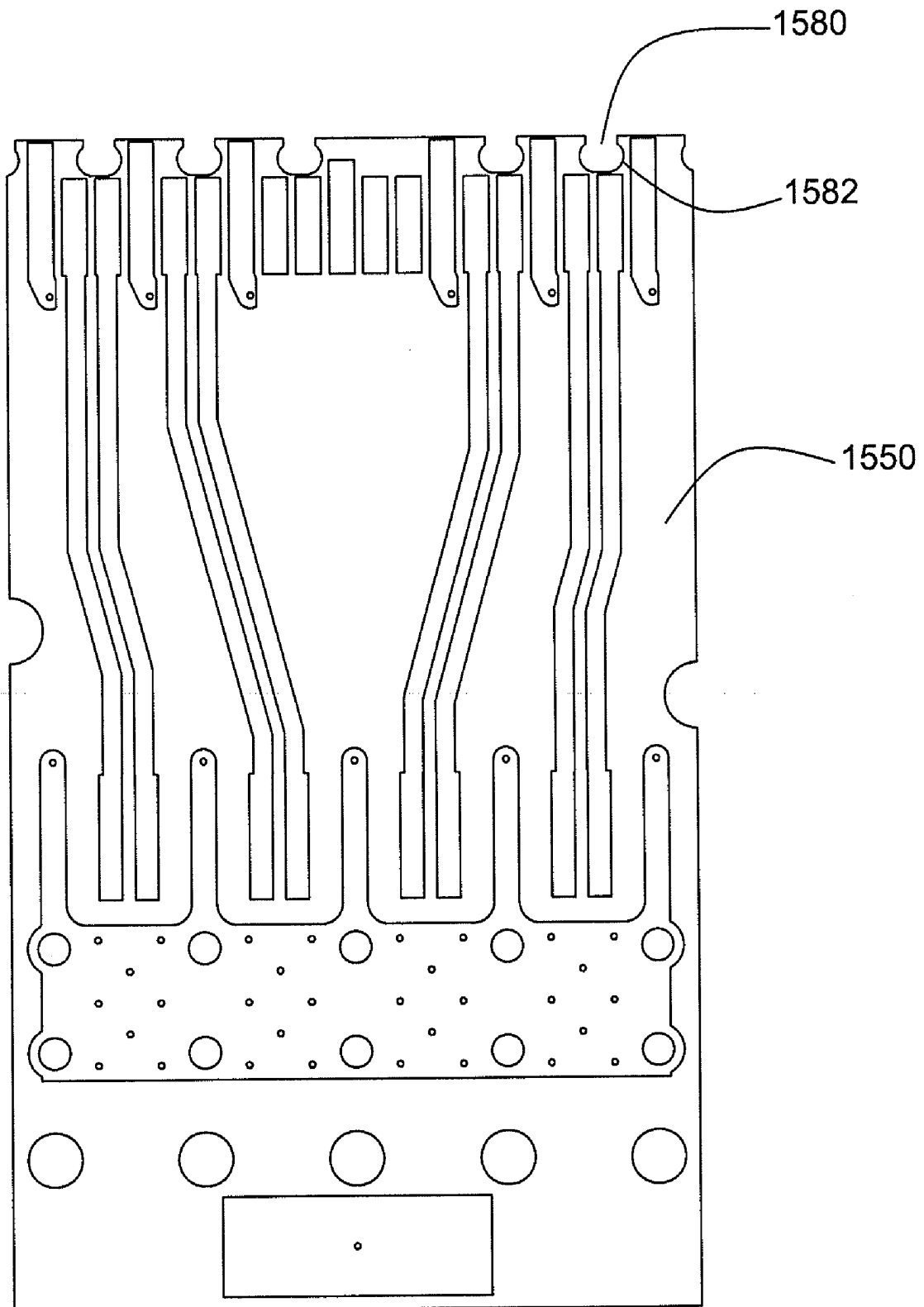

FIG. 37

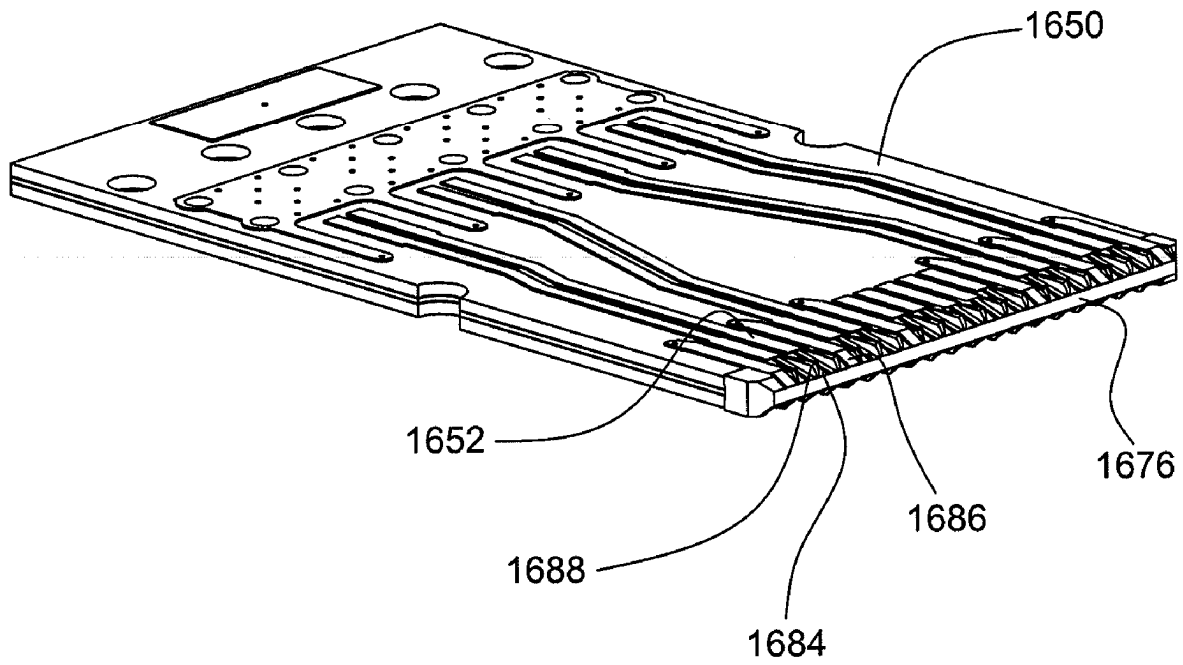

FIG. 38

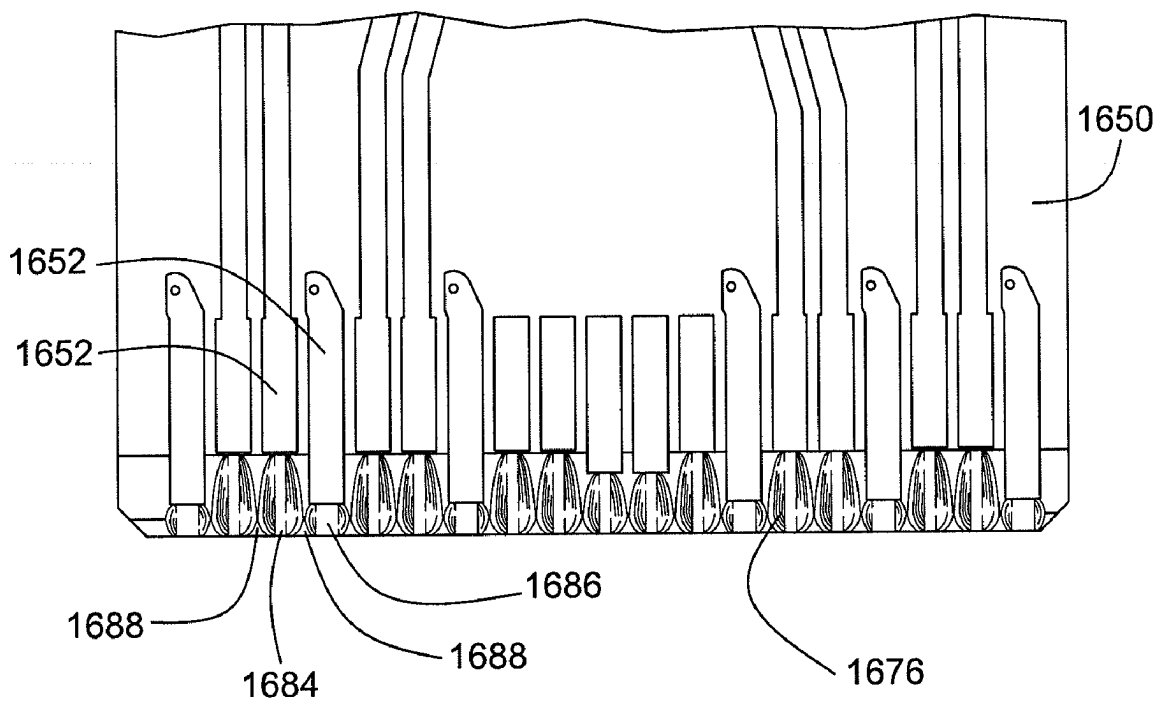

FIG. 39

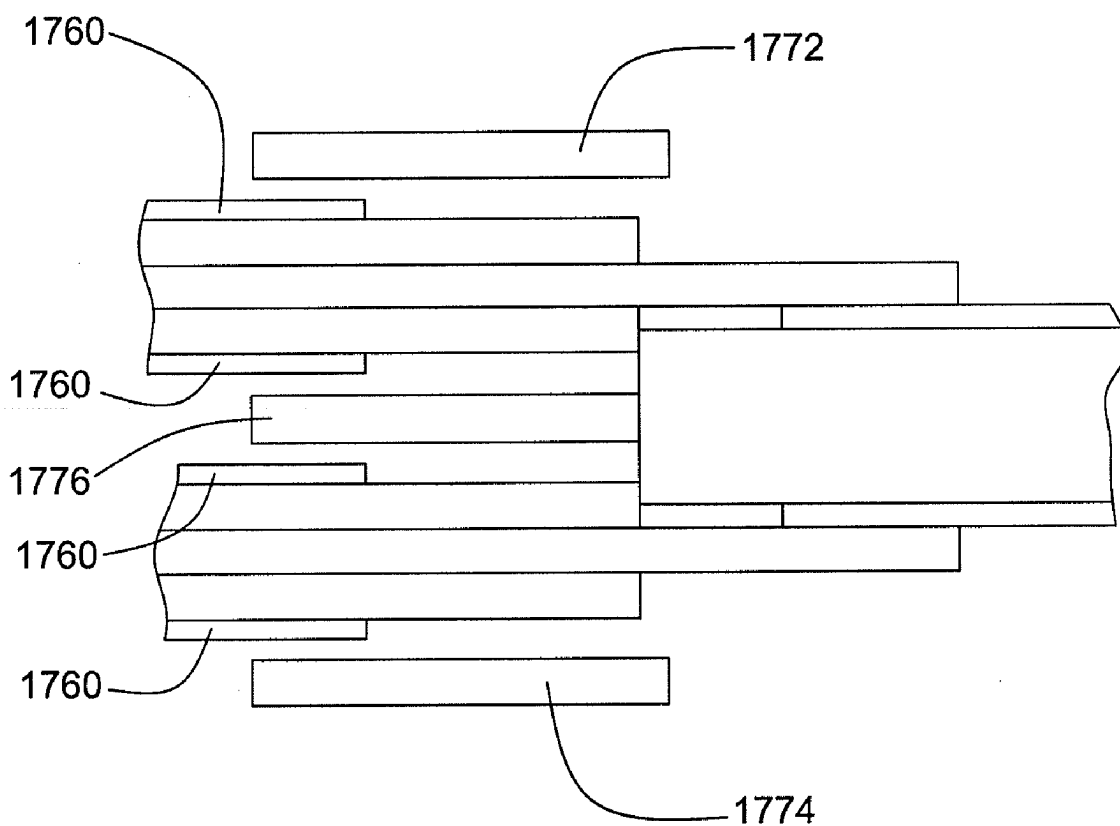

FIG. 40

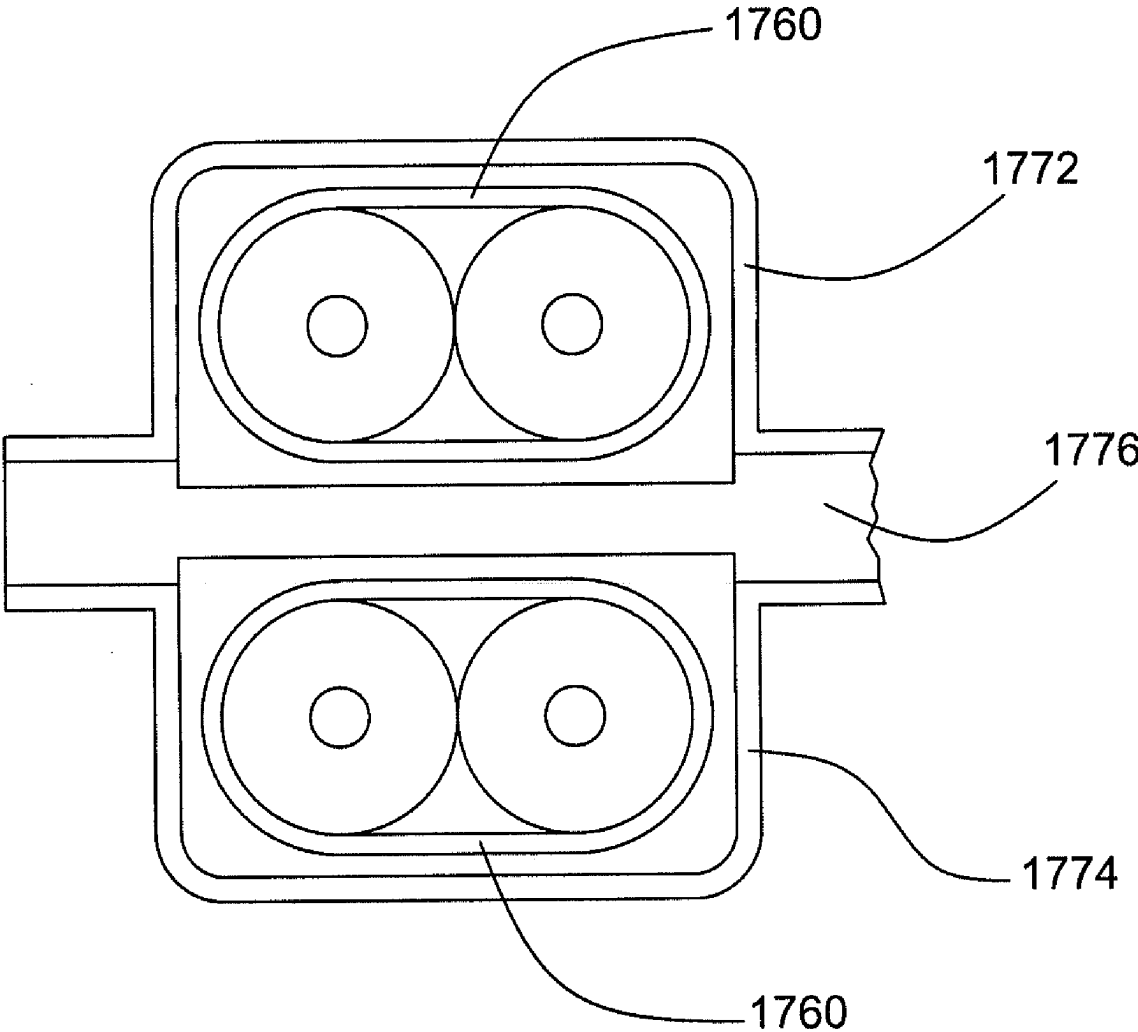

FIG. 41

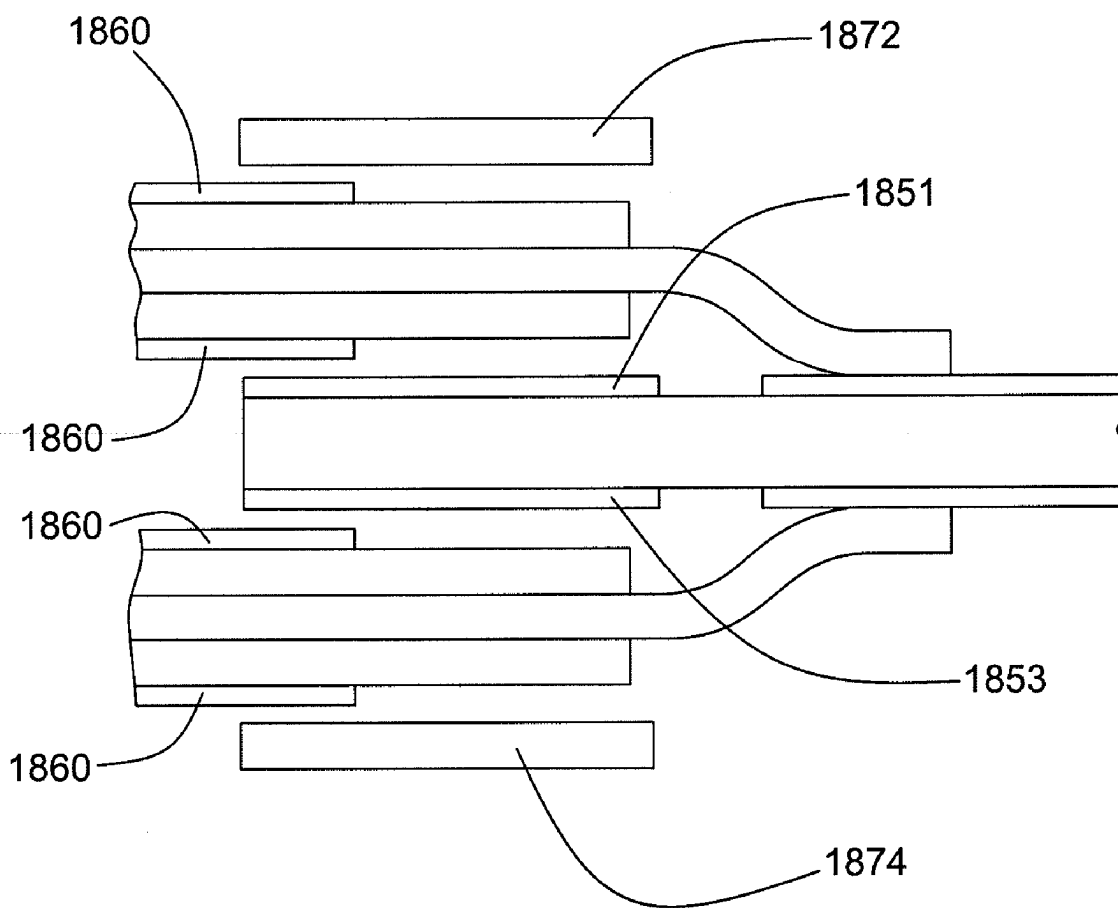
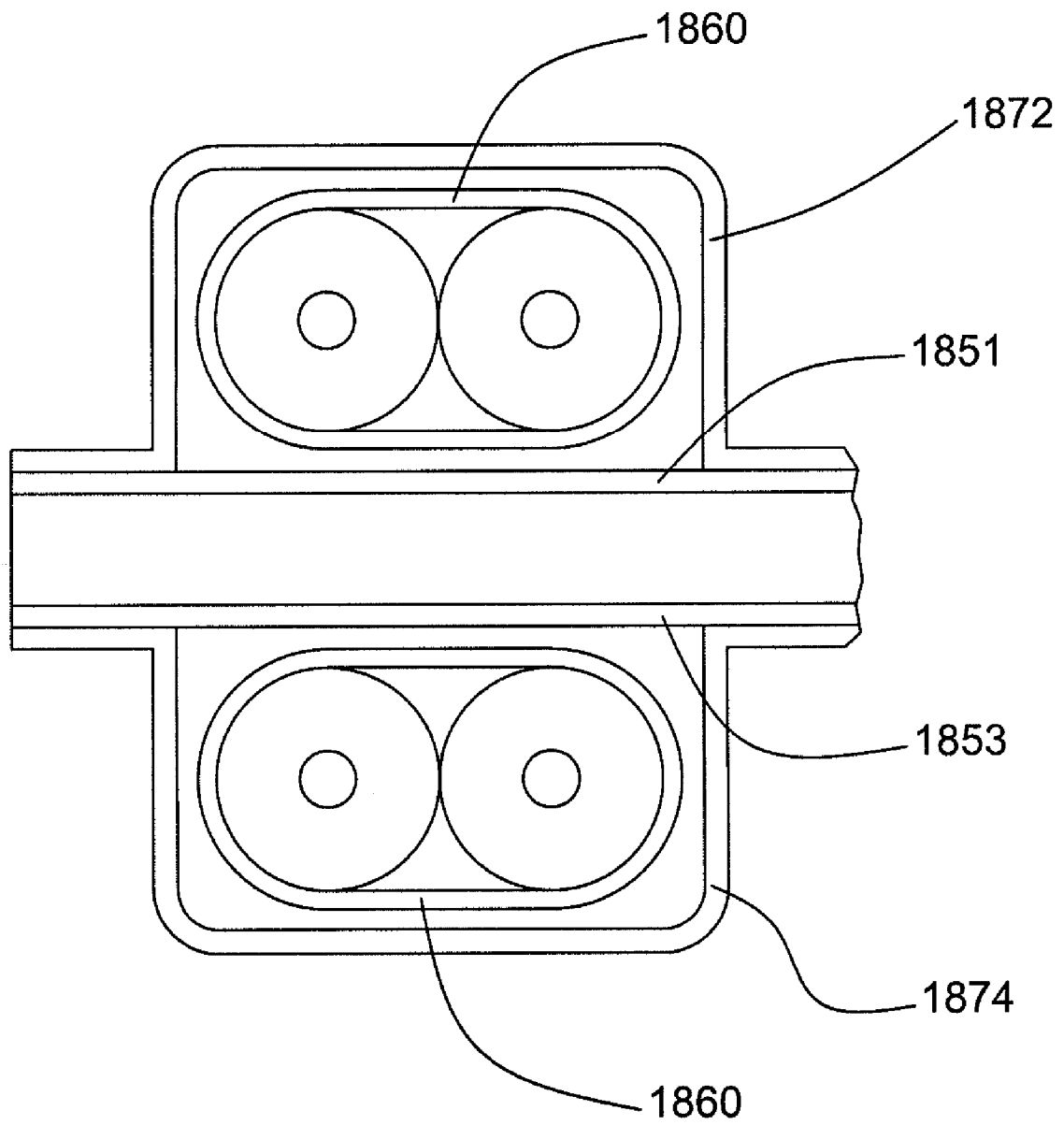

FIG. 42



## ELECTRICAL CONNECTOR

### BACKGROUND

**[0001]** Cable assemblies may be used to connect one system component with another system component. The cable assembly may include a plug connector for connection with a receptacle in a component. The wires in the cable assembly may be shielded in order to prevent cross-talk. The cable assemblies may also need to maintain a constant impedance along the plug connector.

### BRIEF SUMMARY

**[0002]** The cable assembly may include a plug connector and a cable. The plug connector may include a back shell, a cover, a board assembly, and a latch assembly. The board assembly may include a substrate. The substrate may be a printed circuit board.

**[0003]** Printed circuit boards are usually manufactured in standard panel sizes and the panel may include two or more printed circuit boards. The pads and traces of the printed circuit boards may be connected together through tie-bars. Each individual printed circuit board is then cut off from the panel at the tie-bars. The printed circuit board may then have the chamfers applied. Due to the cut-off process and/or the chamfering process, the exposed edges of the tie bars and the fiberglass of the printed circuit board can be found on the cut-off edge of the printed circuit board. In order to prevent a loose fiber from entering the contact area and/or to prevent the rough tie bar edge from removing the plating on the mating contact, the edge of the printed circuit board may be enclosed with a material. The material may either be an overmolded plastic or a coating of material, such as, a conformal coating. The material may encapsulate the fibers on the edge of the printed circuit board in order to prevent fibers from separating from the edge. In addition, the material may provide a transition between the printed circuit board edge and the pads.

**[0004]** The cable assembly may include one or more pairs of wires. Cross talk between wire pairs that are inside the cable is minimal because each wire pair is wrapped by a conductive shield. In order to reduce the crosstalk in the areas where the cable shield is removed, a shielding assembly may be used. In one embodiment, the shielding assembly may include a top shield, a bottom shield and an intermediate shield. The shielding assembly may provide 360 degrees of shielding for the wire pair.

**[0005]** In another embodiment of a shielding assembly, the shield assembly may include a top shield and a bottom shield. The printed circuit board may have one or more ground planes. The ground plane may be located on the upper surface of the printed circuit board. The shield assembly and the ground plane may provide 360 degrees of shielding for the wire pairs.

**[0006]** The printed circuit board may be made of several layers. The printed circuit board may have a trace layer, a core layer, and a ground plane layer. The ground plane layer may have a portion which is a solid layer and another portion which is a non-solid layer. The non-solid portion may have portions with a conductive material and other portions with openings. The non-solid portion of the ground plane may increase the impedance of the pads which are located above the non-solid portion. Thus, smaller traces may be used above the solid portion of the ground plane and larger pads may be

used above the non-solid portion of the ground plane so that the impedance may remain the same along the printed circuit board.

**[0007]** Several cable assemblies may be connected to a back plane which includes receptacles for the cable assemblies. In order to facilitate the insertion and/or removal of a cable assembly, the end portion of the cable assembly may include angled portions. The angled portions allow the user to push and/or grasp the cable assembly for insertion and/or removal of the cable assembly. The angled portions may have a series of protrusions. The protrusions may facilitate the pushing and/or grasping of the cable assembly.

### BRIEF DESCRIPTION OF THE DRAWINGS

**[0008]** FIG. 1 is a perspective view of a cable assembly.  
**[0009]** FIG. 2 is an exploded view of the cable assembly.  
**[0010]** FIG. 3 is another exploded view of the cable assembly.  
**[0011]** FIG. 4 is a top view of the cable assembly with the cover removed.  
**[0012]** FIG. 5 is a top view of the printed circuit board.  
**[0013]** FIG. 6 is a cross-sectional view taken along line 6-6 in FIG. 5.  
**[0014]** FIG. 7 is an exploded view of the cable assembly.  
**[0015]** FIG. 8 is a perspective view of the cable assembly.  
**[0016]** FIG. 9 is a cross-sectional view taken along line 9-9 of FIG. 8.  
**[0017]** FIG. 10 is a cross-sectional view taken along line 10-10 of FIG. 8.  
**[0018]** FIG. 11 is a rear perspective view of the cable assembly.  
**[0019]** FIG. 12 is a perspective view of the cable assembly with the overmold located near the rear of the shields.  
**[0020]** FIG. 13 is a perspective view of another embodiment of the cable assembly with the overmold located partially over the shields.  
**[0021]** FIG. 14 is a perspective view of another embodiment of the cable assembly with the overmold located completely over the shields.  
**[0022]** FIG. 15 is an exploded view of another embodiment of a cable assembly.  
**[0023]** FIG. 16 is a perspective view of the printed circuit board in FIG. 15.  
**[0024]** FIG. 17 is a perspective view of the cable assembly in FIG. 15.  
**[0025]** FIG. 18 is a cross-sectional view taken along line 18-18 of FIG. 17.  
**[0026]** FIG. 19 is a cross-sectional view taken along line 19-19 of FIG. 17.  
**[0027]** FIG. 20 is a perspective view of another embodiment of the cable assembly.  
**[0028]** FIG. 21 is a perspective view of the cable assembly in FIG. 20.  
**[0029]** FIG. 22 is an exploded view of the cable assembly in FIG. 21.  
**[0030]** FIG. 23 is a perspective view of the cable assembly in FIG. 21 with overmold material.  
**[0031]** FIG. 24 is a perspective view of another embodiment of the cable assembly.  
**[0032]** FIG. 25 is a perspective view of another embodiment of the cable assembly.  
**[0033]** FIG. 26 is a perspective view of another embodiment of a cable assembly with a portion of the printed circuit board broken away.

[0034] FIG. 27 is a cross-sectional view taken along line 27-27 of FIG. 26.

[0035] FIG. 28 is a partial top view of the printed circuit board.

[0036] FIG. 29 is a perspective view of several cable assemblies mounted to a back plane.

[0037] FIG. 30 is a side view of FIG. 29.

[0038] FIG. 31 is a perspective view of another embodiment of a cable assembly.

[0039] FIG. 32 is an exploded view of the cable assembly in FIG. 31.

[0040] FIG. 33 is a perspective view of another embodiment of a top shield.

[0041] FIG. 34 is an exploded view of another embodiment.

[0042] FIG. 35 is an exploded view of another embodiment.

[0043] FIG. 36 is a top view of the printed circuit board in FIG. 35.

[0044] FIG. 37 is a perspective view of another embodiment.

[0045] FIG. 38 is a top view of the printed circuit board in FIG. 37.

[0046] FIG. 39 is a cross-sectional view similar to FIG. 9 of another embodiment.

[0047] FIG. 40 is a cross-sectional view similar to FIG. 10 of another embodiment.

[0048] FIG. 41 is a cross-sectional view similar to FIG. 18 of another embodiment.

[0049] FIG. 42 is a cross-sectional view similar to FIG. 19 of another embodiment.

#### DESCRIPTION

[0050] Referring to FIG. 1 the cable assembly 100 may include a plug connector 102, a cable 104, and a second connector 106. Referring to FIGS. 2 and 3, the plug connector 102 may include a housing 108, a board assembly 110 and a latch assembly 112. The housing 108 may include a back shell 116 and a cover 118. The latch assembly 112 may include a latch frame 120, a latch release 122 and compression springs 124, 126. The latch assembly 112 may be used to attach the plug connector 102 to a mating receptacle. The cable 104 may include wires 130, a cable exit collar 132, and a shrink sleeve 134. The cable assembly may include a dust cap 136 for use during shipment of the cable assembly. The dust cap 136 may be removed prior to connecting the plug connector to a mating receptacle. Rivets 138, 140 may be used to attach the cover 118 to the back shell 116. Referring to FIGS. 3 and 4, the rivets 138, 140 may be inserted into holes 142, 144 in the back shell and into holes 146, 148 in the cover and then the rivets 138, 140 would be deformed to prevent the removal of the rivets 138, 140. In other embodiments, screws or other fasteners may be used instead of the rivets and/or in combination with the rivets. The housing may be made of metal, such as, a zinc alloy with a copper flash underplating and a nickel plating. In another embodiment, the housing may be made of aluminum with a copper flash underplating and a nickel plating. In another embodiment, the housing may be made of a plastic with a copper flash underplating and a nickel plating.

[0051] In one embodiment, the connector 106 may be a plug connector similar to plug connector 102. In other embodiments, the plug connector 106 may be a Small Form-factor Pluggable (SFP) connector, a SFP+ connector, a CXP connector, a microGIGaCN connector or other connector. In other embodiments, the cable assembly may include one,

two, three, four or more plug connectors on each end and/or along the length of the cable assembly.

[0052] Referring to FIGS. 4 and 5, the board assembly 110 may include a substrate 150. The substrate 150 may be a printed circuit board. The printed circuit board 150 may include pads 152 and traces 154 on the surface of the printed circuit board. The traces transmit electrical signals across the printed circuit board. For example, the traces may transmit signals from the contacts of a mating receptacle to the wires in the cable assembly. The pads 152 and traces 154 may extend above the surface of the printed circuit board 150. Referring to FIGS. 5 and 6, the printed circuit board 150 may include chamfers 156, 158. The chamfers 156, 158 may facilitate the insertion of the printed circuit board 150 into the receptacle. For example, referring to FIG. 6, the receptacle may include contacts 160, 162. In the unengaged position, the contacts may extend below the surfaces 164, 166 of the printed circuit board. If the printed circuit board did not have the material 176 on the chamfers 156, 158 when the printed circuit board 150 is inserted into the receptacle, the contacts 160, 162 may engage the chamfers 156, 158 which may act as a ramp and allow the contacts 160, 162 to move upward.

[0053] Printed circuit boards are usually manufactured in standard panel sizes and the panel may include two or more printed circuit boards. Referring to FIGS. 5 and 6, the pads 152 and traces 154 of the printed circuit boards may be connected together through tie-bars 168. Each printed circuit board is then cut off from the panel at the tie-bars 168. The printed circuit board may then have the chamfers 156, 158 applied. Due to the cut-off process and/or the chamfering process, the exposed edges 170 of the tie bars 168 and the fiberglass 172 of the printed circuit board may be found on the cut-off edge of the printed circuit board. If the printed circuit board edge is mated with a contact on a receptacle, a fiber from the fiberglass may be dragged into the contact area between the printed circuit board pad 152 and the contact. Also, the sharp tie-bar edge 170 can skive or remove plating from the contact 160, 162 during the insertion process.

[0054] In order to prevent a loose fiber from entering the contact area and/or to prevent the rough edge 170 from removing the plating on the mating contact, the edge 174 of the printed circuit board may be enclosed with a material 176. The material 176 may be an overmolded plastic or a coating of material. The coating may be a conformal coating, a paint, an acrylic, a silicone, a polyurethane, an ultra-violet cured coating, a water based coating, a fluoroacrylic, a physical vapor deposition coating (such as, by thermal evaporation or by sputtering), a chemical vapor decomposition coating, a urethane acrylate (such as, Dymax 984-LVUF by Dymax Corporation, Torrington, Conn., USA), a polyurethane (such as, Humiseal 1A33 by Chase Corporation, Bridgewater, Mass., USA), a urethane (such as, Humiseal 1A20 by Chase Corporation, Bridgewater, Mass., USA), and a urethane (such as, Hysol PC18M by Henkel AG, Dusseldorf, Germany). The material 176 may encapsulate the fibers on the edge of the printed circuit board in order to prevent fibers from separating from the edge. In addition, the material 176 may provide a transition between the printed circuit board edge 174 and the pads 152. The material 176 may be less abrasive than the edge of the printed circuit board. Embodiments with the overmolded material are shown in FIGS. 34-38.

[0055] Referring to FIG. 7, the cable assembly 100 may include several pairs of wires. For example, the cable may include a first wire pair 180 with wires 182, 184, a second

wire pair 190 with wires 192, 194, a third wire pair 200 with wires 202, 204, a fourth wire pair 210 with wires 212, 214, a fifth wire pair 220 with wires 222, 224, a sixth wire pair 230 with wires 232, 234, a seventh wire pair 240 with wires 242, 244, and an eighth wire pair 250 with wires 252, 254. In other embodiments, the cable assembly may include one to thirty-two or more pairs of wires. The cable assembly may include wire pairs in increments of two. The cable assembly 100 may include drain wires 186, 206, 226, 246.

[0056] Cross talk between differential wire pairs is a measure of the amount of voltage that can couple from one transmission differential wire pair to another wire pair. Cross talk increases when the differential wire pairs are placed in close proximity to each other. In addition, the wires may create or be subject to electromagnetic interference (“EMI”).

[0057] Referring to FIG. 7, cross talk and/or EMI between wire pairs 180, 190, 200, 210, 220, 230, 240, 250 that are inside the cable is minimal because each wire pair is wrapped by a conductive shield 260. To solder or terminate the wires 182, 184 to the printed circuit board 150, the cable shield 260 and the insulation 262 must be removed and the wires 182, 184 must be exposed. The areas 264 that are stripped of the cable shield 260 may cause or be subject to cross talk and/or EMI. The areas 264 may have a length 266. The length 266 may have a first range from about 0 mm to about 10 mm, a second range from about 0 mm to about 5 mm, and a third range from about 0 mm to about 4 mm. In one embodiment, the length 266 may be 3.8 mm. FIG. 8 shows the wire pairs 180, 190, 200, 210 terminated on one side of the printed circuit board 150. The other side of the printed circuit board 150 will have similar terminations.

[0058] In order to reduce the crosstalk and/or EMI in the areas 264 where the cable shield 260 is removed, a shielding assembly 270 may be used. In one embodiment, the shielding assembly may include a top shield 272, a bottom shield 274, and an intermediate shield 276. The top shield 272 may have a shielding portion 278 for each pair of wires. In this embodiment, the top shield 272 may have four shielding portions 278. The shielding portions 278 may be connected. In other embodiments, the shielding portions may be separate components. The shielding portion 278 may include a top portion 280, a first side portion 282 and a second side portion 284. The top shield 272 may include one or more grounding legs 286. The grounding leg 286 may be connected to the ground trace 288 on the printed circuit board 150. The grounding leg 286 may be connected by soldering, conductive epoxy, or by a mechanical attachment, such as, a two lead attachment or a compliant pin. An example of a two lead attachment is shown in FIG. 22. An example of a compliant pin attachment is shown in FIG. 33.

[0059] Referring to FIG. 9, the top shield 272, the bottom shield 274, and the intermediate shield 276 provide shielding for the areas 264 without the cable shielding 260. Referring to FIG. 10, the top portion 280, the first side portion 282 and the second side portion 284 provide shielding for the top, and sides of the first wire pair 180. The intermediate shield 276 may provide shielding for the bottom of the first wire pair 180. Thus, the shielding assembly 270 may provide 360 degrees of shielding for the first wire pair 180. Similarly, the shielding assembly 270 may provide shielding for the other wire pairs, such as, the second wire pair 190, the third wire pair 200, and the fourth wire pair 210.

[0060] Referring to FIG. 10, the bottom shield 274 may be similar to or the same as the top shield 272. For example, the

bottom shield 274 may provide shielding for the bottom and sides of the fifth wire pair 220. The intermediate shield 276 may provide shielding for the top of the fifth wire pair 220. The shielding assembly 270 may provide shielding for the other wire pairs, such as, the fifth wire pair 220, the sixth wire pair 230, the seventh wire pair 240 and the eighth wire pair 250.

[0061] Referring to FIGS. 9 and 10, the cable shielding 260 may contact the top shield 272, the bottom shield 274 and the intermediate shield 276 in order to maintain the ground path. In another embodiment shown in FIGS. 39 and 40, the cable shielding 1760 may not contact the top shield 1772, the bottom shield 1774, and the intermediate shield 1776. The cable shielding may contact the drain wires within the cable in order to maintain the ground path. In another embodiment, the cable shielding may contact the top shield and the bottom shield, but may not contact the intermediate shield. In another embodiment, the cable shielding may contact the intermediate shield, but may not contact the top shield and bottom shield. Other embodiments may have different combinations of contact between the cable shield and the shielding assembly.

[0062] The wires may be attached to the printed circuit board 150 in the following manner. The wire pairs may be stripped of the conductive shield 260 and the insulation 262. The wire pairs may be placed in a fixture to hold the wires in position. Referring to FIG. 7, the intermediate shield 276 and printed circuit board 150 may be positioned between the wires. The top shield 272, the bottom shield 274, and the intermediate shield 276 may be attached to the printed circuit board 150. The shields 272, 274, 276 may be attached by soldering, conductive epoxy, or mechanical attachment as noted herein. The wires, such as wires 182, 184, may be soldered to the printed circuit board 150. If the shields are attached by soldering, the soldering of the shields may occur at the same time as the soldering of the wires. In another embodiment, the soldering of the shields may occur at a different time than the soldering of the wires. Referring to FIG. 3, the overmold material 290 is molded over the wires. The overmold material may be an insulative plastic material.

[0063] The overmold material may be located in different positions with respect to the shields. In one embodiment as shown in FIG. 12, the overmold material 290 is located near the rear of the shields 272, 274, 276. In another embodiment as shown in FIG. 13, the overmold material 291 is located partially over the shields 272, 274, 276. In another embodiment as shown in FIG. 14, the overmold material 292 is located completely over the shields 272, 274, 276. In another embodiment, the overmold material may be located over the shields and over the solder attachments for the wires.

[0064] In another embodiment of the assembly process, the wire pairs may be stripped of the conductive shield 260 and the insulation 262. The wire pairs may be placed in a fixture to hold the wires in position. The overmold material 290 is molded over the wires while the wires are in the fixture. The wires are then removed from the fixture. Referring to FIG. 7, the intermediate shield 276 and printed circuit board 150 may be positioned between the wires. The top shield 272, the bottom shield 274, and the intermediate shield 276 may be attached to the printed circuit board 150. The shields 272, 274, 276 may be attached by soldering or mechanical attachment as noted herein. The wires, such as wires 182, 184, may be soldered to the printed circuit board 150. If the shields are attached by soldering, the soldering of the shields may occur

at the same time as the soldering of the wires. In another embodiment, the soldering of the shields may occur at a different time than the soldering of the wires.

[0065] Referring to FIG. 15, another embodiment of a shielding assembly is shown. The shield assembly 470 may include a top shield 472 and a bottom shield 474. In one embodiment, the top shield 472 and bottom shield 474 may be similar to the top shield 272 and bottom shield 274 in FIG. 7. The printed circuit board 350 may be similar to the printed circuit board 150 in FIG. 7 except that the printed circuit board 350 may have one or more ground planes 351, 353 as shown in FIGS. 15 and 16. The ground plane 351 may be located on the upper surface of the printed circuit board. The ground plane 353 may be located on the lower surface of the printed circuit board. Referring to FIG. 15, the insulation 362 on the wires is positioned on the printed circuit board 350. For example, the insulation 362 may be positioned over the ground plane 351.

[0066] Referring to FIGS. 17-19, the top shield 472 and the ground plane 351 may provide 360 degrees of shielding for the area 464 of the first wire pair 380 without the cable shield 460. The top shield 472 and ground plane 351 may also provide 360 degrees of shielding for the other wire pairs on the top surface of the printed circuit board. Similarly, the bottom shield 474 and the ground plane 353 may provide 360 degrees of shielding for the area 464 of the wire pair 420 without the cable shield 460. The bottom shield 474 and the ground plane 353 may also provide 360 degrees of shielding for the other wire pairs located on the bottom of the printed circuit board 350.

[0067] Referring to FIGS. 18 and 19, the cable shield 460 for the first wire pair 380 may contact the top shield 472 and the ground plane 351 in order to maintain the ground path. The cable shield 460 for the other wire pairs on the top of the printed circuit board may similarly contact the top shield 472 and ground plane 351. The cable shield 460 for the wire pair 420 may contact the bottom shield 474 and the ground plane 353 in order to maintain the ground path. The cable shield 460 for the other wire pairs on the bottom of the printed circuit board may similarly contact the bottom shield 474 and ground plane 353. In another embodiment shown in FIGS. 41 and 42, the cable shielding 1860 may not contact the first ground plane 1851, the second ground plane 1853, the top shield 1872, and the bottom shield 1874. The cable shielding may contact the drain wires within the cable in order to maintain the ground path. In another embodiment, the cable shielding may contact the first ground plane and the second ground plane, but may not contact the top shield and bottom shield. In another embodiment, the cable shielding may contact the top shield and the bottom shield, but may not contact the first ground plane and the second ground plane. Other embodiments may have different combinations of contact between the cable shield and the shielding assembly.

[0068] Referring to FIG. 17, the wires may be attached to the printed circuit board using the assembly processes as noted herein with respect to the embodiment shown in FIG. 7 except that the embodiment in FIG. 17 does not require the assembly of a separate intermediate shield.

[0069] Referring to FIG. 20, two embodiments of shield assemblies 570, 670 are shown. The shield assembly 570 may include a top shield 572. The top shield 572 may be similar to top shield 472 except that top shield 572 may be used with one pair of wires and the top shield 572 may have two leads 573, 575 for attachment to the printed circuit board 550. The

printed circuit board 550 may include an opening 577. The opening 577 may be a plated opening which may be connected to the ground planes of the printed circuit board. The opening 577 may receive the two leads 573, 575. Referring to FIG. 22, the two leads 573, 575 may include hook portions 579, 581. The hook portions 579, 581 may be wider than the opening 577. When the leads 573, 575 are inserted into the opening 577, the leads may deflect inward and allow the hook portions 579, 581 to enter the opening. When the hook portions 579, 581 exit the opening 577, the leads 573, 575 and hook portions 579, 581 extend outward. The hook portions 579, 581 may engage the rim of the opening 577 and prevent the top shield 572 from being removed. In another embodiment, the leads may not include the hook portions and may be held in the opening by the outward force of the leads on the opening and/or by a friction fit.

[0070] The top shield 572 may have two sets of leads 583, 585 and the two sets of leads 583, 585 may be positioned diagonally from each other. The diagonal positioning allows the shield 572 to be used in a bottom location and allows the leads to be inserted into openings 577 which are being used by the upper and lower shields in adjacent locations.

[0071] The top shield 572 may be used with one wire pair or multiple top shields 572 may be used with multiple wire pairs. For example, eight top shields 572 may be used with eight wire pairs. The top shields 572 may be used in conjunction with other top shields, such as, a top shield for a four wire pair or a top shield for a two wire pair. For example, a printed circuit board for an eight wire pair may use two top shields 572 and one top shield 672 on the top surface of the printed circuit board as shown in FIG. 20, and may use a top shield 272 on the bottom of the printed circuit board.

[0072] Referring to FIG. 20, the shield assembly 670 may include a top shield 672. The top shield 672 may be similar to top shield 572 except that the top shield 672 may be used with two wire pairs and the top shield 672 may include a bridge portion 687. The top shield 672 may include two sets of leads 683, 685 which may operate in a similar manner as the sets of leads 583, 585. The bridge portion 687 may connect together the two unshaped portions for each wire pair. The bridge portion 687 may include an aperture 691. The apertures 691 may be used to solder the bridge portion 687 to the ground plane 651. In another embodiment, the apertures 691 may not be soldered.

[0073] Referring to FIG. 23, an overmold material 690 may be molded onto the printed circuit board 550. The overmold material may be a plastic. Referring to FIG. 20, the printed circuit board 550 may include apertures 696. The overmold material 690 may flow into the apertures 696 and may prevent the overmold material 690 from being separated from the printed circuit board 550.

[0074] Referring to FIG. 20, the printed circuit board 550 may include a drain wire mounting pad 698. The mounting pad 698 may provide a location for soldering a drain wire 686.

[0075] Referring to FIG. 24, another embodiment of a shield assembly 770 is shown. The top shield 772 is similar to top shield 672. In this embodiment, a pin 793 may be inserted into a hole 791. The printed circuit board 750 may include a hole to receive the pin 793. After the pin 793 is inserted into the holes, the end 795 of the pin 793 may be deformed to hold the pin 793 and the shield 772 in position.

[0076] Referring to FIG. 25, another embodiment of a shield assembly 870 is shown. The top shield 872 is similar to top shield 672 except that top shield 872 may include four sets

of leads **883**, **885**, **897**, **899**. The aperture **891** in the bridge portion **887** may be used for solder or a pin as described herein.

[0077] As noted herein, a top shield for two wire pairs may be used with other top shields, such as, a top shield for one wire pair, a top shield for a two wire pair and/or a top shield for a four wire pair.

[0078] Referring to FIG. 26, the printed circuit board **950** may be made of several layers. Referring to FIG. 27, the printed circuit board **950** may have a trace layer **961**, a core layer **963**, a ground plane layer **965**, a center layer **967**, a trace layer **971**, a core layer **973**, and a ground plane layer **975**. The trace layers **961**, **971** and the ground plane layers **965**, **975** may be made of a conductive material, such as, copper. The core layers **963**, **973** and the center layer **967** may be made of an insulative material, for example, a composite of a resin epoxy reinforced with a woven fiberglass mat, such as, FR408. The printed circuit board **950** may also include a solder mask layer **969** which is located around the trace layer **961**. The printed circuit board **950** may include a solder mask layer **979** which may be located around the trace layer **971**. In other embodiments, the printed circuit board may have more or less layers. For example, in other embodiments, the printed circuit board may have one or more trace layers, one or more core layers, and one or more ground layers.

[0079] Referring to FIG. 26, the ground plane layer **965** may have a portion **981** which is a solid layer and another portion **983** which is a non-solid layer. Referring to FIG. 28, the non-solid portion **983** may have portions **985** with a conductive material and other portions with openings **987**, for example, with no conductive material. Thus, at the openings **987**, the center layer **967** is located below these openings **987**. The non-solid portion **983** may increase the impedance of the pads **989** which are located above the non-solid portion **983**. Thus, referring to FIG. 26, smaller traces **991** may be used above the solid portion **981** of the ground plane and larger pads **989** may be used above the non-solid portion **983** of the ground plane so that the impedance may remain the same along the printed circuit board. In one embodiment, the traces **991** may have a width of about 0.45 mm and the pads **989** may have a width of about 0.6 mm. In another embodiment, the traces may have a first area per unit length and the pads may have a second area per unit length. The first area of unit length may be less than the second area per unit length.

[0080] Referring to FIG. 28, in one embodiment, the openings **987** have a square shape. The openings **987** may have a first dimension **1001**. The first dimension **1001** may have a range from about 0.025 mm to about 1.27 mm. In one embodiment, the first dimension **1001** may be 0.6 mm. The openings **987** may have a second dimension **1003**. The second dimension **1003** may have a first range from about 0.025 mm to about 1.27 mm. In one embodiment, the second dimension **1003** may be 0.6 mm. The portion **985** between the openings may have a dimension **1005**. The dimension **1005** may have a first range from about 0.025 mm to about 1.27 mm. In one embodiment, the dimension **1005** may be 0.1 mm. The openings may have an angle **1007** between one side of the opening and an adjacent side of the opening. The angle **1007** may have a first range from about 1 degree to about 179 degrees. In one embodiment, the angle **1007** is 90 degrees. The center of the openings may be located a distance **1009** from the edge of the printed circuit board. The distance **1009** may have a range from about 0.025 mm to 1.27 mm. In one embodiment, the distance **1009** may be 0.495 mm. The center of the openings

in the first row may be spaced a distance **1011** from the center of the openings in the second row. The distance **1011** may have a first range from about 0.025 mm to about 1.27 mm. In one embodiment, the distance **1011** may be 0.495 mm. The center of the openings in the first row may be spaced a distance **1013** from the center of the openings in the third row by a distance. The distance **1013** may have a first range of about 0.05 mm to about 2.54 mm. In one embodiment, the distance **1013** may be 0.990 mm. The non-solid layer portion **983** may have a distance **1015** from the edge of the printed circuit board to the center of the last row of openings. The distance **1015** may have a first range from about 0.127 mm to about 25.4 mm. In one embodiment, the distance **1015** may be 3.465 mm.

[0081] In other embodiments, the openings may have other shapes such as circles, ovals, parallelograms, rectangles, triangles or other polygons.

[0082] Referring to FIG. 29, several cable assemblies **1101**, **1103**, **1105**, **1107**, **1111**, **1113**, **1115**, **1117** may be connected to a back plane **1121** or to a motherboard which includes receptacles for the cable assemblies. In order to facilitate the insertion and/or removal of a cable assembly, the end portion **1119** of the cable assembly may include angled portions **1123**, **1125**. The angled portions **1123**, **1125** allow the user to grasp the cable assembly for insertion and/or removal of the cable assembly. Without the angled portions, the cable assembly would have an end portion which is flat and which would be more difficult to push and/or grasp when the cable assemblies are close together. The angled portions **1123**, **1125** may have a series of protrusions **1127**. The protrusions **1127** may facilitate the pushing and/or grasping of the cable assembly. The end portion **1119** may be connected to the latch assembly **1112**. The user may be able to move the latch assembly **1112** by pulling on the end portion **1119** or on the latch release **1122**.

[0083] FIGS. 31 and 32 show another embodiment of a cable assembly **1200**. The cable assembly **1200** may be similar to the cable assemblies disclosed herein except that the cable assembly **1200** may include an end portion **1219** with overmold material **1229**. The overmold material **1229** may be an insulative plastic material. Referring to FIG. 31, the end portion **1219** may be similar to the end portion **1119**. The end portion **1219** may include angled portions **1223**, **1225**. The angled portions **1223**, **1225** may include protrusions **1227**. The angled portions **1223**, **1225** may include protrusions **1228**. The protrusions **1228** may be wider than the adjacent protrusion **1227** and may provide a surface for the user to push and/or grasp the cable assembly. The end portion **1219** may be connected to the latch assembly **1212**. The user may be able to move the latch assembly **1212** by pulling on the end portion **1219** or on the latch release **1222**. The top surface of the end portion **1219** may include a series of protrusions **1231**. Referring to FIG. 32, the overmold material **1229** may be molded onto the back shell **1206**. The back shell **1206** may include one or more detents **1233**. The overmold material **1229** may flow into the detents **1233** and provide a better attachment of the overmold material **1229** to the back shell **1206**. An end portion with overmold material may be used with any of the embodiments disclosed herein, as appropriate.

[0084] Referring to FIG. 33, another embodiment of a shield is shown. The shield **1372** may be similar to the shield **472** except that the shield **1372** may include one or more compliant pins **1392**. The compliant pin may include two legs **1394**, **1396** and an aperture **1398** between the legs **1394**,

1396. The legs 1394, 1396 may be joined at the distal end. When the pin 1392 is inserted into the opening in a printed circuit board similar to the opening 577 in FIG. 20, the legs 1394, 1396 may deflect inward. The legs 1394, 1396 may apply an outward force on the opening to prevent removal of the shield 1372 from the printed circuit board. The compliant pin feature may be used with any of the embodiments disclosed herein, as appropriate.

[0085] Referring to FIG. 34, another embodiment of a printed circuit board 1450 is shown. The printed circuit board 1450 may include an overmold material 1476 at the front edge of the printed circuit board. The overmold material 1476 may be an insulative plastic material. The overmold material 1476 may be molded onto the front edge of the printed circuit board. The printed circuit board 1450 may have a portion 1478 of the front edge removed, such as, by machining. The overmold material 1476 may be molded onto the printed circuit board 1450 and may fill the removed portion 1478. The printed circuit board 1450 may include apertures 1480. The overmold material 1476 may flow into the apertures 1480 and may prevent the removal of the overmold material 1476. As noted with respect to FIG. 6, the overmold material 1476 may encapsulate the fibers on the edge of the printed circuit board in order to prevent fibers from separating from the edge. In addition, the overmold material 1476 may provide a transition between the printed circuit board edge and the pads.

[0086] Referring to FIG. 35, another embodiment of a printed circuit board 1550 is shown. The printed circuit board 1550 may include an overmold material 1576 at the front edge of the printed circuit board. The overmold material 1576 may be an insulative plastic material. The overmold material 1576 may be molded onto the front edge of the printed circuit board. The printed circuit board 1550 may include apertures 1580. Referring to FIG. 36, the apertures 1580 may have a larger portion 1582 near the interior of the aperture 1580. The aperture may be in the shape of a key hole. The overmold material 1576 may flow into the apertures 1580 and may prevent the removal of the overmold material 1576. As noted with respect to FIG. 6, the overmold material 1576 may encapsulate the fibers on the edge of the printed circuit board in order to prevent fibers from separating from the edge. In addition, the overmold material 1576 may provide a transition between the printed circuit board edge and the pads. In another embodiment, the printed circuit board may have a portion of the front edge removed, similar to FIG. 34. The overmold material may be molded onto the printed circuit board and may fill the removed portion.

[0087] Referring to FIGS. 37 and 38, another embodiment of a printed circuit board 1650 is shown. The printed circuit board 1650 may include an overmold material 1676 at the front edge of the printed circuit board. The overmold material 1676 may be an insulative plastic material. The overmold material 1676 may be molded onto the front edge of the printed circuit board. The overmold material may include ramps 1684, 1686. The ramps 1684, 1686 may be used to guide the contacts of the mating receptacle onto the pads 1652 on the printed circuit board 1650. The signal ramps 1684 may be used to guide the signal contacts and the ground ramps 1686 may be used to guide the ground contacts. The signal ramps 1684 may be longer than the ground ramps 1686 due to the distance of the respective pads from the edge of the printed circuit board. The angle of the signal ramps 1684 may be less than the angle of the ground ramps 1686. The ramps 1684, 1686 may be curved and may include sidewalls 1688. The

sidewalls 1688 may assist in aligning the contacts with the pads 1652. As noted with respect to FIG. 6, the overmold material 1676 may encapsulate the fibers on the edge of the printed circuit board in order to prevent fibers from separating from the edge. In addition, the overmold material 1676 may provide a transition between the printed circuit board edge and the pads. The printed circuit board 1650 may include apertures, similar to the apertures in FIG. 34 and/or FIGS. 35-36. The overmold material 1676 may flow into the apertures and may prevent the removal of the overmold material 1676. The printed circuit board may have a portion of the front edge removed, similar to FIG. 34. The overmold material may be molded onto the printed circuit board and may fill the removed portion.

[0088] All references, including publications, patent applications, and patents, cited herein are hereby incorporated by reference to the same extent as if each reference were individually and specifically indicated to be incorporated by reference and were set forth in its entirety herein.

[0089] The use of the terms “a” and “an” and “the” and similar referents in the context of describing the invention (especially in the context of the following claims) are to be construed to cover both the singular and the plural, unless otherwise indicated herein or clearly contradicted by context. The terms “comprising,” “having,” “including,” and “containing” are to be construed as open-ended terms (i.e., meaning “including, but not limited to,”) unless otherwise noted. Recitation of ranges of values herein are merely intended to serve as a shorthand method of referring individually to each separate value falling within the range, unless otherwise indicated herein, and each separate value is incorporated into the specification as if it were individually recited herein. All methods described herein can be performed in any suitable order unless otherwise indicated herein or otherwise clearly contradicted by context. The use of any and all examples, or exemplary language (e.g., “such as”) provided herein, is intended merely to better illuminate the invention and does not pose a limitation on the scope of the invention unless otherwise claimed. No language in the specification should be construed as indicating any non-claimed element as essential to the practice of the invention.

[0090] Exemplary embodiments are described herein. Variations of those embodiments may become apparent to those of ordinary skill in the art upon reading the foregoing description. The inventor(s) expect skilled artisans to employ such variations as appropriate, and the inventor(s) intend for the invention to be practiced otherwise than as specifically described herein. Accordingly, this invention includes all modifications and equivalents of the subject matter recited in the claims appended hereto as permitted by applicable law. Moreover, any combination of the above-described elements in all possible variations thereof is encompassed by the invention unless otherwise indicated herein or otherwise clearly contradicted by context.

1. A cable assembly comprising a cable including a pair of wires, a housing, a printed circuit board within the housing, the printed circuit board includes pads, the wires include a wire shielding and wire insulation, the wires are attached to the pads on the printed circuit board, the wires include an unshielded portion with the wire shielding removed from the wire insulation, the unshielded portion is located near the pads, and second shielding is located at the unshielded portion to provide shielding for the wire pair.

2. The cable assembly of claim 1 wherein the second shielding provides shielding around the unshielded portion of the wire pair.

3. The cable assembly of claim 2 wherein the second shielding provides 360 degrees of shielding around the unshielded portion of the wire pair.

4. The cable assembly of claim 1 wherein the second shielding includes a top shield and an intermediate shield.

5. The cable assembly of claim 4 wherein the top shield is unshaped.

6. The cable assembly of claim 4 wherein the intermediate shield is a metal shield.

7. The cable assembly of claim 4 wherein the intermediate shield is a ground plane on the surface of the printed circuit board.

8. The cable assembly of claim 1 wherein the cable includes a second pair of wires, the second pair of wires include a wire shielding and wire insulation, the second pair of wires are attached to the pads on the printed circuit board, the second pair of wires include a second unshielded portion with the wire shielding removed from the wire insulation, the second unshielded portion is located near the pads, and second shielding is located at the second unshielded portion to provide shielding for the second pair of wires.

9. A cable assembly comprising a cable including a pair of wires, a housing, a printed circuit board within the housing, the pair of wires attached to the printed circuit board, the printed circuit board includes a substrate and a conductive pad on the surface of the substrate, the substrate has an edge, the conductive pad is located near the mating edge of the substrate, a material is located on the edge of the substrate.

10. The cable assembly of claim 9 wherein the material covers the edge of the substrate.

11. The cable assembly of claim 9 wherein the material is less abrasive than the edge of the substrate.

12. The cable assembly of claim 9 wherein the material is a coating.

13. The cable assembly of claim 9 wherein the material is a plastic.

14. The cable assembly of claim 9 wherein the material provides a transition between the edge of the substrate and the conductive pad.

15. A cable assembly comprising a cable including a pair of wires, a housing, a printed circuit board, the wires are attached to the printed circuit board, the printed circuit board includes conductive pads and traces, the printed circuit board includes a ground layer, the ground layer includes a solid portion and a non-solid portion, the pads are located above the non-solid portion of the ground layer, and the traces are located above the solid portion of the ground layer.

16. The cable assembly of claim 15 wherein the non-solid portion of the ground layer increases the impedance of the pads located above the non-solid portion of the ground layer.

17. The cable assembly of claim 15 wherein the traces located above the solid portion of the ground layer have the same impedance as the pads located above the non-solid portion of the ground layer.

18. The cable assembly of claim 17 wherein the traces located above the solid portion of the ground layer have a first width, the pads located above the non-solid portion of the ground layer have a second width, the first width is less than the second width.

19. The cable assembly of claim 17 wherein the traces located above the solid portion of the ground layer have a first area per unit length, the pads located above the non-solid portion of the ground layer have a second area per unit length, the first area per unit length is less than the second area per unit length.

20. A cable assembly comprising a cable including a pair of wires, a housing, a printed circuit board, the wires attached to the printed circuit board, the housing includes an end portion, and the end portion includes angled portions.

21. The cable assembly of claim 20 wherein the angled portions include protrusions.

22. The cable assembly of claim 20 wherein the end portion includes overmold material.

23. The cable assembly of claim 20 wherein the housing includes a latch assembly, the end portion is located on the latch assembly.

\* \* \* \* \*