

## RECOMMENDATION ITU-R BT.1298\*

**Enhanced wide-screen NTSC TV transmission system**

(Question ITU-R 10/6)

(1997)

The ITU Radiocommunication Assembly,

*considering*

- a) that the 16:9 aspect ratio provides an enhanced viewing experience, particularly on large screen receivers, and is likely to be adopted for new digital services;
- b) that there are indications that the public interest in the new 16:9 aspect ratio is growing;
- c) that NTSC services are likely to continue for the time being, whatever new services are introduced;
- d) that the enhanced definition television (EDTV-II) system can provide high quality 16:9 pictures for enhanced wide-screen receivers whilst maintaining compatibility with existing 4:3 receivers (using 16:9 letterbox);
- e) that the signalling system required by EDTV-II for receiver control has been recommended in Recommendation ITU-R BT.1119;
- f) that Recommendation ITU-R BT.1118 recommends that when enhancements to existing television system are made, some or all of the modular enhancements and features listed in Annex 1 to that Recommendation should be used;
- g) further that three of these modules and features are:
  - coder requirements for accommodating wide aspect ratio signals,
  - coder requirements for increased resolution,
  - methods to reduce impairments that might be created on the 4:3 conventional receivers by the enhancement signals;
- h) that EDTV-II system provides for the three modules and features listed in § g),

*recommends*

**1** that where administrations or broadcasters wish to enhance the delivery of conventional NTSC (in the case of NTSC system M) television with compatible wide-screen, the EDTV-II system, as specified in Annex 1, should be used.

---

\* Radiocommunication Study Group 6 made editorial amendments to this Recommendation in 2002 in accordance with Resolution ITU-R 44.

## ANNEX 1

**EDTV-II system specification**

## CONTENTS

- 1 Introduction
  - 2 Features of EDTV-II transmission system
    - 2.1 Vertical conversion to 360-line letterbox picture
    - 2.2 Enhancement by vertical helpers (VH, VT)
    - 2.3 Enhancement by horizontal helper (HH)
    - 2.4 Wide-screen signalling system
    - 2.5 Chrominance signal, audio signal
  - 3 Input signal formats for EDTV-II transmission system
  - 4 Wide-screen technique of EDTV-II
  - 5 EDTV-II techniques for enhancement of picture quality
    - 5.1 Enhancement technique for vertical resolution
      - 5.1.1 Vertical high resolution helper (VH)
      - 5.1.2 Vertical-temporal helper (VT)
      - 5.1.3 Multiplexing of VH and VT
    - 5.2 Enhancement technique for horizontal resolution
    - 5.3 Interference visibility reduction techniques in multiplexing the vertical helpers
      - 5.3.1 Gain control by correlation in active image area
      - 5.3.2 Adaptive set-up level control
  - 6 Signalling
- Appendix 1 to Annex 1 Recommended practices

**1 Introduction**

The second generation EDTV (EDTV-II) is an enhanced wide-screen NTSC transmission system, which provides existing NTSC broadcasters with wide-screen (16:9 aspect ratio) and high picture quality, while maintaining the compatibility with NTSC transmission system and with existing NTSC receivers.

The first generation EDTV (CLEARVISION) was recommended as Recommendation ITU-R BT.797. CLEARVISION's enhancement modules are optional to EDTV-II, and the modules are equally applicable to both conventional NTSC and EDTV-II signals.

## 2 Features of EDTV-II transmission system

An EDTV-II signal is derived using some or all of the processes as listed in Table 1, and illustrated in Fig. 1. The vision signal shall be described as “EDTV-II” both when one or more helpers (VH, VT and HH) are used and when the wide-screen signalling (Annex 2 to Recommendation ITU-R BT.1119) is used.

TABLE 1

The enhancement features incorporated in EDTV-II transmission

Enhancement	Mandatory or optional in EDTV-II
Letterbox	Mandatory
Vertical high resolution helper (VH)	Optional <sup>(1)</sup>
Vertical temporal helper (VT)	Optional <sup>(1)</sup>
Horizontal helper (HH)	Optional <sup>(1)</sup>
Wide-screen signalling	Mandatory
Ghost cancellation reference signal	Optional

<sup>(1)</sup> At least one from VH, VT and HH shall be used.

### 2.1 Vertical conversion to 360-line letterbox picture

This is the conversion of the 16:9 aspect ratio source picture with 480 active lines to a 16:9 aspect ratio letterbox picture with 360 active lines.

### 2.2 Enhancement by vertical helpers (VH, VT)

The helpers for vertical high resolution are transmitted taking advantage of the black bands above and below the active picture area. The vertical helper (VH) signal carries the vertical luminance component higher than 360 lines per picture height in the still portion of the picture. VT carries the vertical temporal component in order to realize progressive scanning at the receiver. Both VH and VT modulate the colour subcarrier and are then transmitted in the black bands above and below the active picture area. Techniques are employed in an EDTV-II transmission in order to minimize the visibility on 4:3 receivers of the VH signals.

FIGURE 1  
An example of the block diagram of EDTV-II encoder

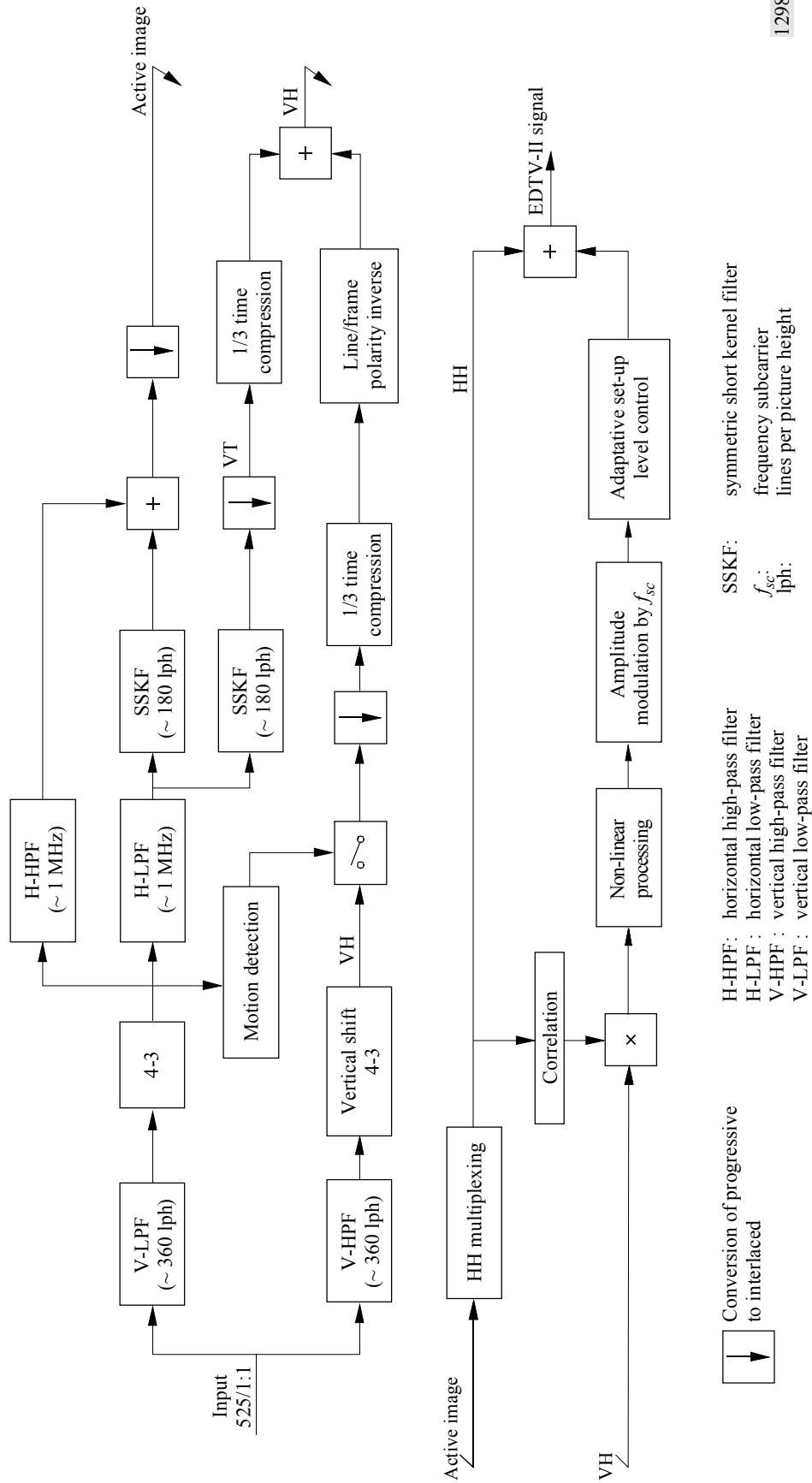

H-HPF : horizontal high-pass filter  
 H-LPF : horizontal low-pass filter  
 V-HPF : vertical high-pass filter  
 V-LPF : vertical low-pass filter  
 SSKF : symmetric short kernel filter  
 $f_{sc}$  : frequency subcarrier  
 lph : lines per picture height

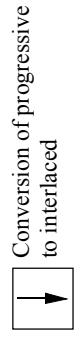

The component carried by VH or VT is shown in Fig. 2.

FIGURE 2  
Resolution (for still and moving pictures) and components  
carried by VH, VT and HH

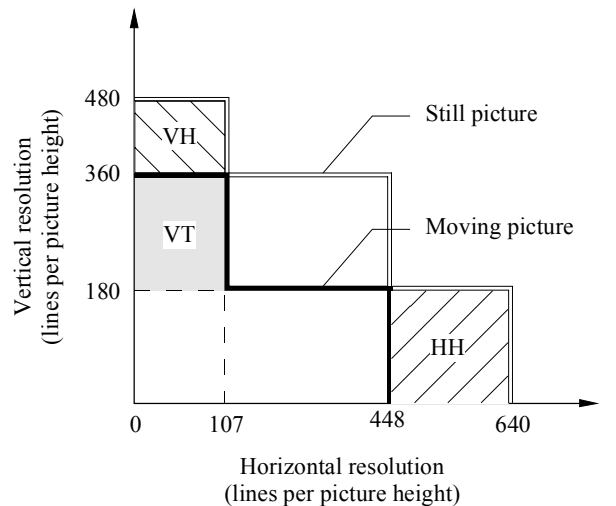

1298-02

### 2.3 Enhancement by horizontal helper (HH)

The helper for horizontal high resolution is transmitted by using the “Fukinuki hole”. The horizontal luminance component between 4.2 and approximately 6 MHz is transmitted as HH by frequency division multiplexing into the active area of the letterbox signal.

The component carried by HH is shown in Fig. 2.

### 2.4 Wide-screen signalling system

The wide-screen signalling system provides for identification of an EDTV-II signal, and indicates which kinds of helpers are actually transmitted. The wave form of the signal and the assignment of the bits are described in Annex 2 to Recommendation ITU-R BT.1119.

### 2.5 Chrominance signal, audio signal

The chrominance signal is transmitted in the active area of the letterbox after the conversion from source picture with 480 active lines to 360 active lines.

The audio signal is completely the same as that of an NTSC system.

The features of EDTV-II transmission are summarized in Table 1.

## 3 Input signal formats for EDTV-II transmission system

Signal formats 525/59.94/2:1, 525/59.94/1:1 and 1125/60/2:1 are considered to be basic input signal formats. Other formats may be used for encoding after conversion to these basic input signal formats.

At the receiving side, EDTV-II programmes can be displayed in the letterbox format on 4:3 NTSC receivers without decoding, and be displayed in wide-screen format on 16:9 progressive or interlaced scanning receivers.

#### 4 Wide-screen technique of EDTV-II

16:9 aspect ratio pictures can also be viewed on existing 4:3 receivers by using the letterbox format as well as on 16:9 receivers. In the encoder, 480 active scanning lines are converted to 360 active scanning lines by means of a 480 line to 360 line (4-3) converter. Specifically, 180 scanning lines per field are assigned to the centre part of the letterbox format for the active image area and 30 scanning lines per field are given to the black areas above and below the active image area (see Fig. 8). In the wide-screen receiver, 16:9 pictures are reproduced by means of a 360 line to 480 line (3-4) converter.

As described in § 5.1.1, the 4-3 converter operates by vertical sample rate down conversion following a vertical low-pass filter for anti-aliasing. When the vertical high resolution helper (VH) is multiplexed, the vertical low-pass filter shown in Fig. 3 shall be used. The same filter can be used for anti-aliasing when the VH is not multiplexed.

FIGURE 3  
Frequency characteristics of low-pass filter and high-pass filter  
in relation to the active image area and VH  
of the letterbox signal

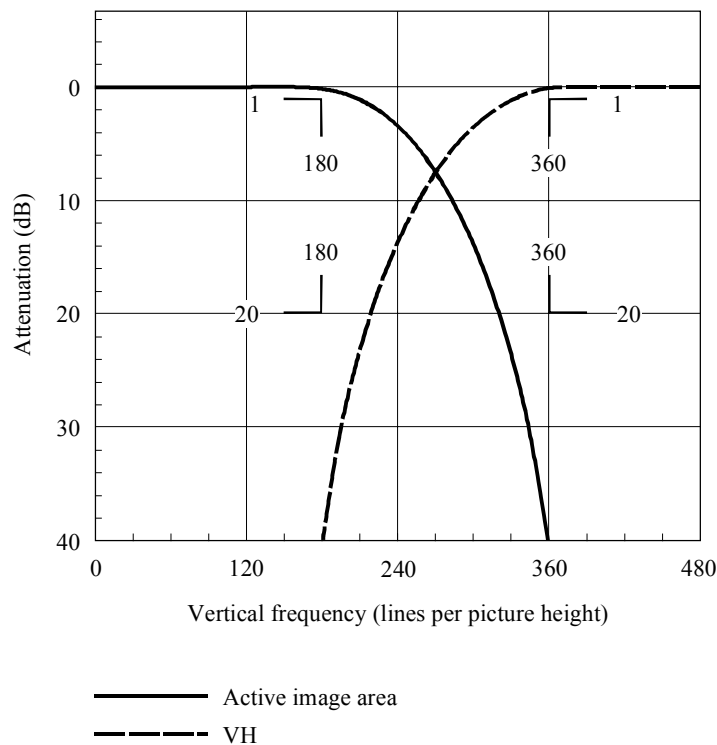

1298-03

## 5 EDTV-II techniques for enhancement of picture quality

EDTV-II utilizes the enhancement techniques for vertical resolution and horizontal resolution of luminance signals described below in order to transmit high quality wide-screen pictures using a letterbox format. Further visibility on 4:3 receivers caused by the vertical helpers is minimized by implementing interference reduction techniques in multiplexing the vertical helpers in the black areas.

### 5.1 Enhancement technique for vertical resolution

The vertical helper signal, which is transmitted to improve vertical resolution, is made up of both a vertical high resolution helper (VH) and/or a vertical-temporal resolution helper (VT). The vertical helper signal is multiplexed in the upper and lower black areas as shown in Fig. 8 and its signal level in these areas before multiplexing is set to 0 IRE units. In multiplexing the vertical helper signal, the active image area portion of the letterbox signal is obtained by converting the active scanning lines from 480 lines to 360 lines, following the conversion from progressive scanning to interlaced scanning.

#### 5.1.1 Vertical high resolution helper (VH)

First, 480 active lines are limited in the vertical frequency domain by a high-pass filter, then their signal polarities are alternately reversed from the beginning of the scanning lines. After that, VH is generated by 480 to 360 scanning line conversion and progressive to interlaced scan conversion. VH is multiplexed only for stationary pictures.

The high-pass filter has the following characteristics:

- less than 1 dB down at 360 lines per picture height,
- greater than or equal to 20 dB down at 180 lines per picture height.

In multiplexing VH, the active image area portion of the letterbox signal is obtained by converting the number of active scanning lines from 480 to 360 after limiting the vertical frequency bandwidth by a low-pass filter with the following characteristics:

- less than 1 dB down at 180 lines per picture height,
- greater than or equal to 20 dB down at 360 lines per picture height.

Figure 3 shows the frequency characteristics of the high-pass filter and the low-pass filter mentioned above. Line number (or position) of the signal which is sub-sampled for the progressive to interlaced scan conversion is the same both for VH and for the active image area signal.

#### 5.1.2 Vertical-temporal helper (VT)

VT is obtained by limiting the vertical frequency bandwidth of the 360 active scanning lines using a high-pass filter ( $H_1(Z)$ ), and converting the scanning format from progressive to interlaced. The coefficients of the high-pass filter are shown in Table 2.

TABLE 2  
Coefficients of  $H_1(Z)$

Line number	Coefficient
$n - 1$	$-1/4$
$n$	$2/4$
$n + 1$	$-1/4$

$(1 \leq n \leq 360)$

In multiplexing VT, the active image area signal in the letterbox signal is obtained by converting the 360 scanning lines from the progressive format to the interlaced format after limiting the vertical frequency bandwidth by a low-pass filter ( $H_0(Z)$ ). The low-pass filter has the coefficients shown in Table 3.

TABLE 3  
Coefficients of  $H_0(Z)$

Line number	Coefficient
$n - 2$	$-1/8$
$n - 1$	$2/8$
$n$	$-1/8$
$n + 1$	$2/8$
$n + 2$	$-1/8$

$(1 \leq n \leq 360)$

$H_1(Z)$  and  $H_0(Z)$  shall be used in conjunction with  $G_1(Z)$  and  $G_0(Z)$  on the reception side, as shown in Fig. 4. This forms a SSKF with perfect reconstruction capability. Figure 5 shows the frequency characteristics of these filters.

FIGURE 4  
SSKF composition

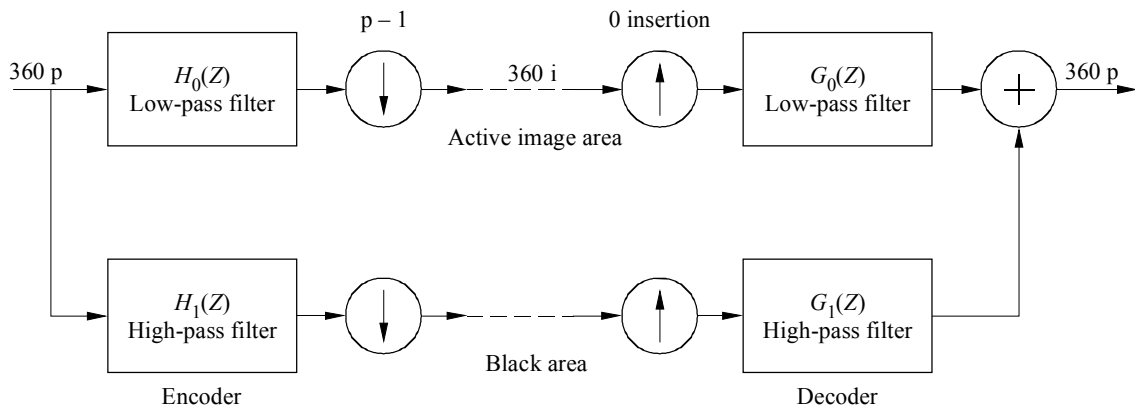

1298-04

Regarding the line numbers which indicate the lines to be sub-sampled for the progressive to interlaced scan conversion both of the active image area and of VT, the VT line numbers are the same as the line numbers of the lines which should be interpolated in the active image area.

**5.1.3 Multiplexing of VH and VT**

The following procedures shall be taken for multiplexing both VH and VT or either of them in the black areas.

*Step 1:* Carry out band limitation for VH and/or VT using a low-pass filter with the following characteristics. These are shown in Fig. 6.

- less than 6 dB down at 0.8 MHz,
- greater than or equal to 6 dB down at 1.0 MHz,
- greater than or equal to 20 dB down at 1.2 MHz.

FIGURE 5  
SSKF frequency characteristics

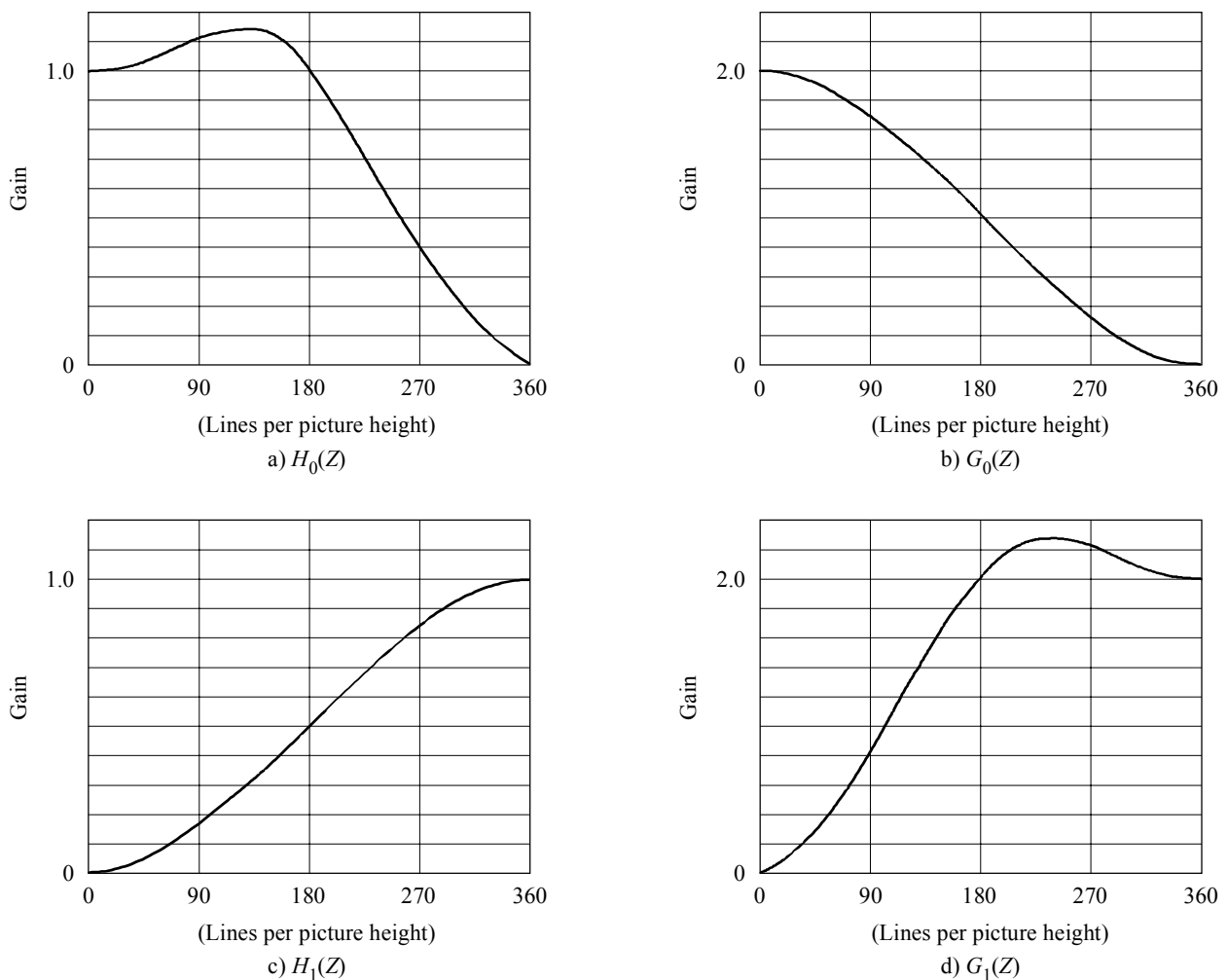

1298-05

*Step 2:* Carry out the following process for VH and VT.

- VH: After each line signal is compressed to one third horizontally, each three lines compressed are arrayed in one scanning line sequentially in order. The polarities of these new lines are alternately reversed from the beginning of the line, and the polarities are also reversed from the lines at the same position in the previous frame. Further, the amplitude is halved.

In polarity reversing, the polarity of line No.  $n$  in the first field and that of line No.  $(n + 263)$  in the next field are made to be the same. In this case, positive polarity is given to the line multiplexed on the 23rd line in the first field of the reference frame (the reference frame serves as a reference phase for the helper). Reference frames occur every two frames.

- VT: Each line signal is first compressed to one third horizontally, and the three lines are arrayed in one line sequentially in the scanning order.

*Step 3:* Add VH and VT after the above processing when multiplexing both of them.

*Step 4:* The signal obtained in Step 2 or Step 3 is used to modulate the amplitude of the vertical helper subcarrier (amplitude modulation with suppressed carrier). Here, the frequency of the vertical helper subcarrier is the same as that of the colour subcarrier, and its phase is delayed by 147 from the colour burst. The modulation gain is set to 1.

*Step 5:* The amplitude of the signal obtained in Step 4 is doubled. The signal is then band limited by a Nyquist filter, whose characteristics are shown in Fig. 7. The normalized gain of this filter at the colour subcarrier frequency is nominally set to 0.5.

FIGURE 6  
Frequency characteristics of horizontal low-pass filter  
for VH/VT multiplexing

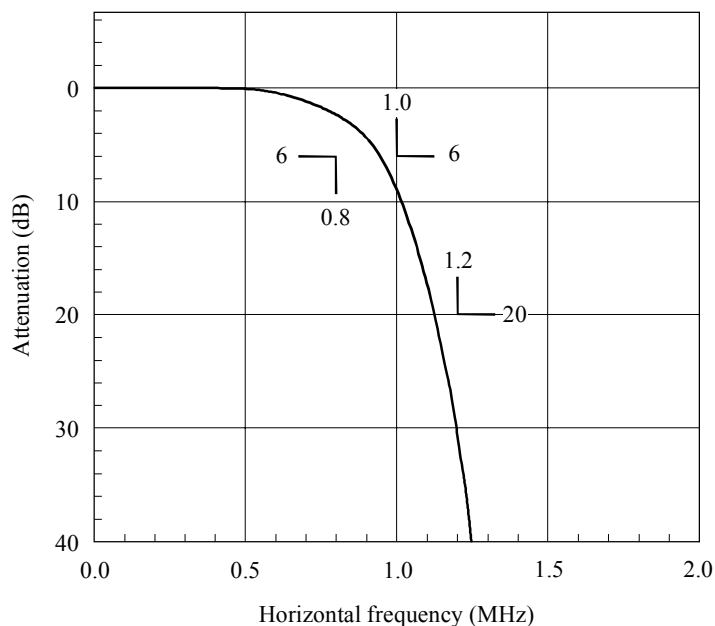

1298-06

FIGURE 7  
Allowable level of the Nyquist filter for vertical helper

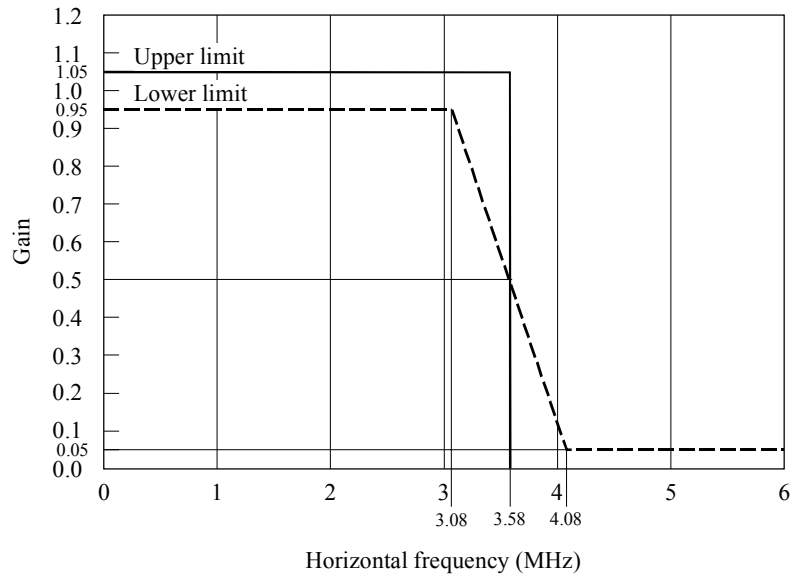

1298-07

The multiplexing positions of the vertical helper are expressed by the following equations.

When  $53 \leq M \leq 142$ ,  $316 \leq M \leq 405$

$$m = \text{INT} \left[ \frac{M - 53 - 263 (P - 1)}{3} \right] + 23 + 263 (P - 1)$$

When  $143 \leq M \leq 232$ ,  $406 \leq M \leq 495$

$$m = \text{INT} \left[ \frac{M - 143 - 263 (P - 1)}{3} \right] + 233 + 263 (P - 1)$$

When  $N = 3L + 5$  ( $L$  is a positive integer)

$$n = \text{INT} \left[ \frac{N - 7}{3} \right] + 7 + 252$$

$$((M - 53 - 263 (P - 1)) - 3 \text{ INT}$$

$$\left[ \frac{M - 53 - 263(P - 1)}{3} \right]$$

where:

$m$ : the line number for multiplexing the vertical helper corresponding to the luminance signal of line No.  $M$

$n$ : the pixel number of line No.  $m$  for multiplexing the vertical helper corresponding to pixel No.  $N$  of line No.  $M$

INT [A] : Integer part of real number A

$P$ :  $P = 1$  in the first field,  $P = 2$  in the next field

$N$ : integers from 6 to 762.

Here, the sampling frequency of the pixels is set to four times the colour subcarrier frequency, and the sampling clock is synchronized with the phase delayed by  $57^\circ$  from the colour burst phase. The 35th pixel is a picture element defined as occurring immediately after the amplitude passes the 50% point during the fall time at the B1's falling edge of the signalling signal. Figure 8 shows the lines and pixel allocations for the helpers.

## 5.2 Enhancement technique for horizontal resolution

The horizontal helper (HH) is multiplexed in a letterbox picture in order to enhance horizontal resolution of the luminance signal. In cases where the vertical helper signal is not multiplexed, the signal levels of the black bands above and below the letterbox picture shall be 0 IRE units. The horizontal high resolution component bandwidth transmitted by HH is 4.2 MHz to approximately 6 MHz.

A lower sideband signal of the horizontal helper subcarrier modulated by horizontal high components above 4.2 MHz using amplitude modulation with suppressed carrier is first generated. The amplitude of HH is halved as a consequence of suppressing the upper sideband.

The frequency of the horizontal helper subcarrier shall be  $16/7$  of the colour subcarrier frequency. The zero crossing point of HH subcarrier's falling edge is defined at the same position as the maximum level of the colour subcarrier, whose phase is delayed  $57^\circ$  from the colour burst signal. This definition is available just after the 50% level point of the falling edge of B1 of wide-screen signalling on the 1st field of a reference frame. Signals dealt with in this way are called HH.

The polarity of the lower sideband signal is inverted on alternate lines from the top line (53, 316), and also the polarity of each line is inverted with respect to the polarity of the same line of the previous frame. As a consequence, the phase of the "phase switched HH" signal on the first of both fields within a frame is the same.

As HH's polarity is inverted every line and every frame as mentioned, the same phase goes down field by field in vertical temporal domain. The phase of HH on the line in the next field, immediately below the present line, will have the same phase. Figure 9 shows an example of the block diagram for HH multiplexing.

FIGURE 8  
Line and pixel allocation for the helper

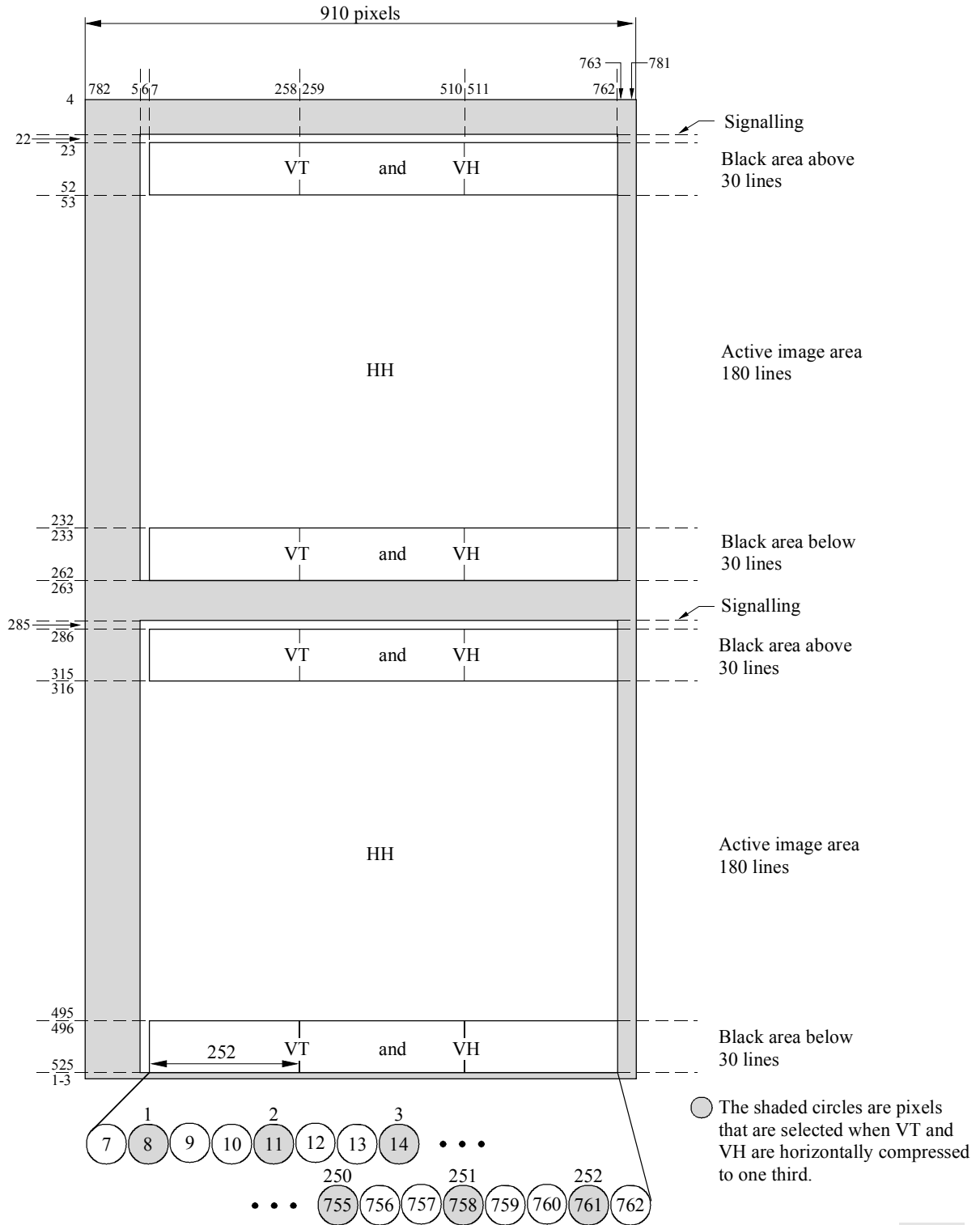

1298-08

FIGURE 9  
An example of the block diagram for HH multiplexing

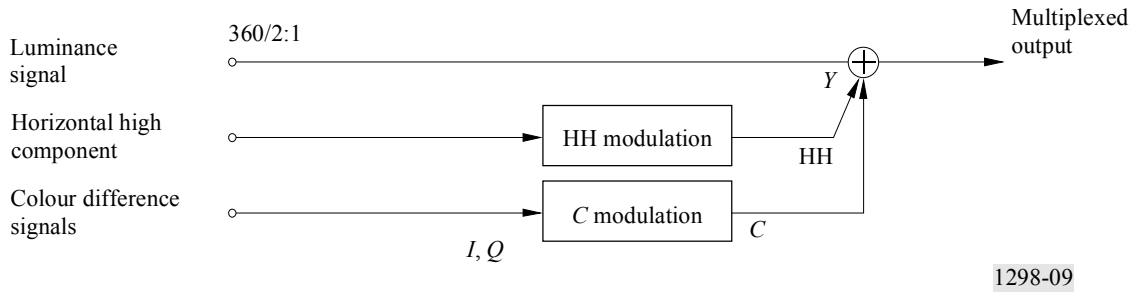

1298-09

### 5.3 Interference visibility reduction techniques in multiplexing the vertical helpers

The following two techniques are used to reduce the interference on existing 4:3 receivers caused by the vertical helpers, when the vertical helpers are inserted above and below the letterbox picture.

#### 5.3.1 Gain control by correlation in active image area

The block diagram of the vertical helper signal gain control according to the correlation between the active image area and the vertical helper signal is given in Fig. 10. In the multiplexing process for VH and VT shown in § 5.1.3, the gain control is performed by multiplying vertical helper signal by the control signal,  $E_{out}$ , obtained from the active image area signal before the process of amplitude modulation with the suppressed carrier (Step 4).

FIGURE 10  
An example of gain control by correlation in active image area

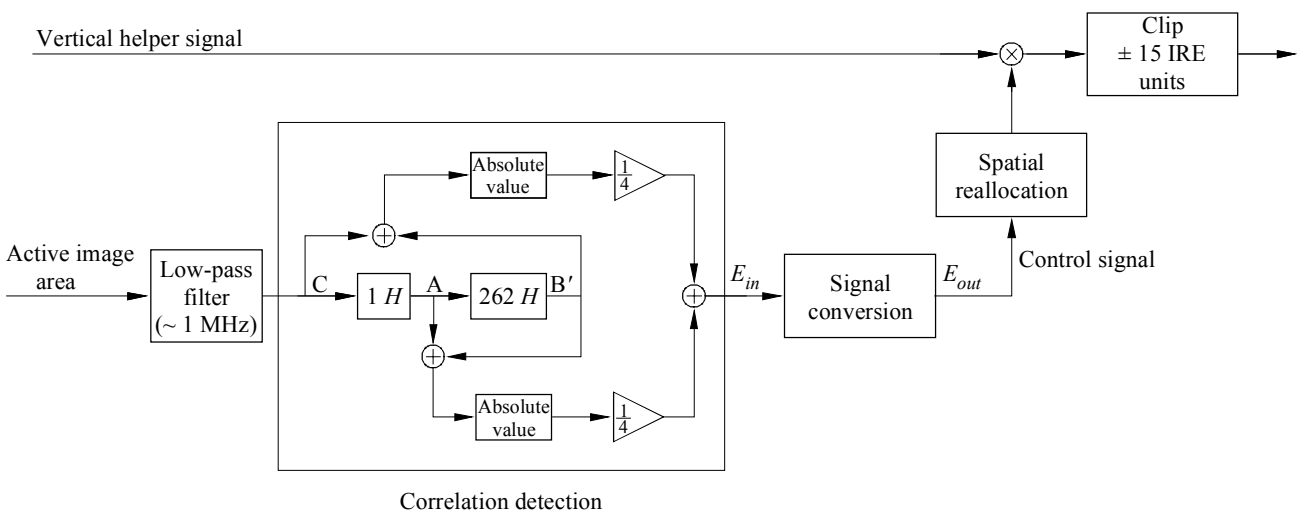

1298-10

After the bandwidth limitation of the active image area signal by a low-pass filter that has the following characteristics, the gain control value to the vertical helper signal is obtained from  $E_{in}$  and  $E_{out}$ , using three lines around the position corresponding to VT as shown in Fig. 11.

- less than 6 dB down at 0.8 MHz;
- greater than or equal to 6 dB down at 1.0 MHz.

$$E_{out} = \frac{1}{0.25 E_{in} + 0.375} \quad (\text{If } E_{out} \text{ is } \leq 0.5, E_{out} \text{ shall be fixed at } 0.5)$$

$$E_{in} = \frac{|A - B'|}{4} + \frac{|B' - C|}{4}$$

where:

- $A$ : luminance signal delayed by 262 lines from line  $B'$
- $B'$ : luminance signal proceeding by 1 field from the location corresponding to VT on the active image area signal
- $C$ : luminance signal of the line next to  $A$ .

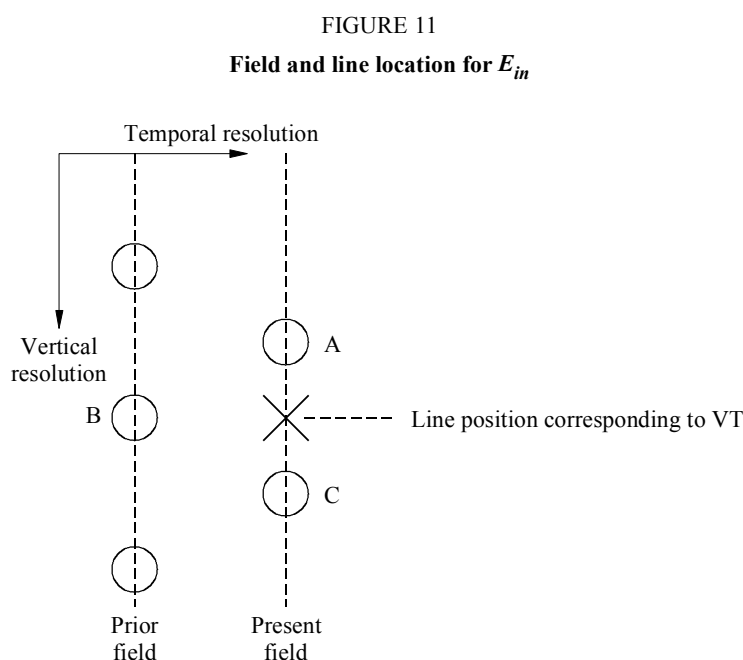

1298-11

The control signal derived from each point along an active picture line is spatially reallocated (see Fig. 10) to control the amplitude of the time multiplexed VT and VH helper signals at their corresponding positions (see Fig. 8).

The maximum value and minimum value of gain controlled vertical helper signals shall be limited to +15 and -15 IRE Units, where the pedestal level is 0 and the white level of the luminance signal is 100.

### 5.3.2 Adaptive set-up level control

Set-up level of the vertical helper signal is controlled by the process based on the following circuit shown in Fig. 12. Delay corresponds to the total delay from the band-pass filter to the low-pass filter.

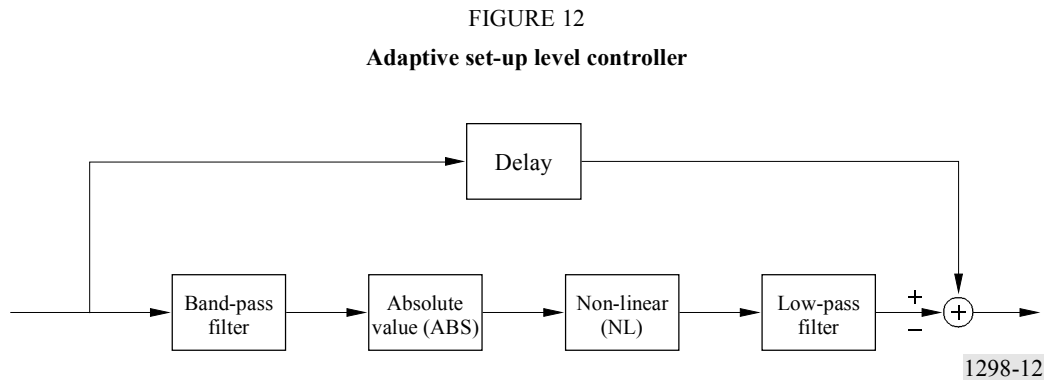

In Fig. 12, the band-pass filter has the following characteristics:

- greater than or equal to 40 dB down at 0 MHz,
- greater than or equal to 15 dB down at 1.0 MHz,
- less than 2 dB down at 3.08 MHz,
- less than 2 dB down at 4.08 MHz.

The low-pass filter has the following characteristics:

- less than 6 dB down at 0.6 MHz,
- greater than or equal to 2 dB down at 1.0 MHz,
- greater than or equal to 20 dB down at 3.08 MHz,
- greater than or equal to 40 dB down at 3.58 MHz.

The frequency characteristics of the band-pass filter and the low-pass filter are shown in Fig. 13.

ABS means a full wave rectifier, NL means a non-linear circuit whose characteristic is shown in Fig. 14.

## 6 Signalling

The wide-screen signalling (WSS) system (Recommendation ITU-R BT.1119, Annex 2) for the 525-line NTSC system shall be used for the EDTV-II system. The following summary is given for information.

The WSS contains information on the aspect ratio of transmitted signals and on the superposition of various picture-quality-helpers and on the field/frame types and so on.

The WSS is inserted into the line 22 and 285 horizontal scanning periods.

Figure 15 shows the signal waveform of WSS and Table 4 indicates the content of WSS information.

FIGURE 13  
The frequency characteristics of the band-pass filter  
and the low-pass filter

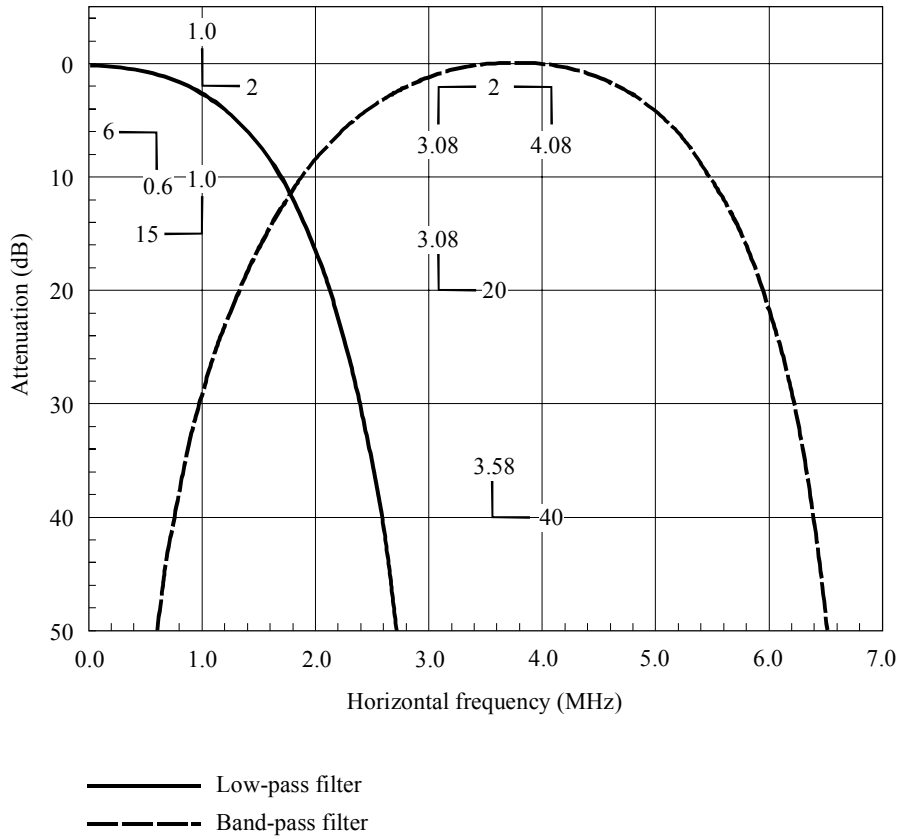

1298-13

FIGURE 14  
Characteristic of NL

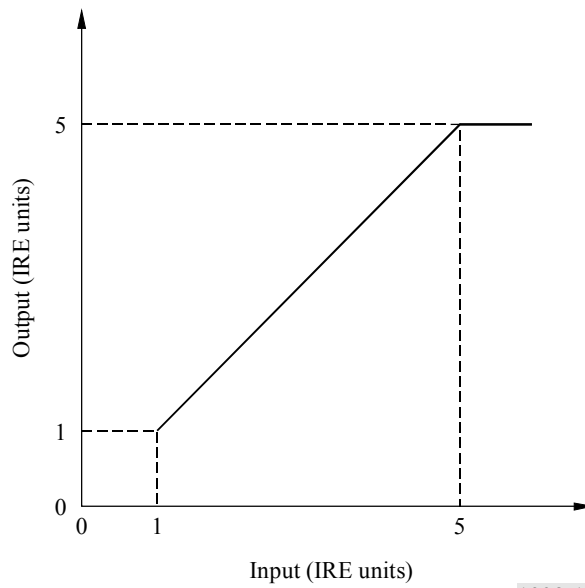

1298-14

FIGURE 15  
The signal waveform of WSS in line 22 and 285

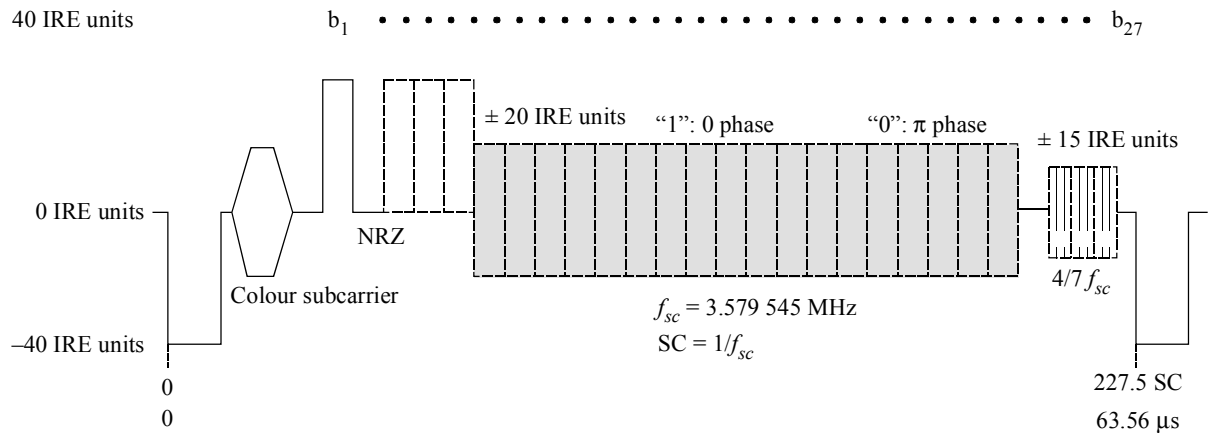

SC: duration of one cycle of chrominance signal subcarrier (SC = 1/3.579 545 μs)

TABLE 4  
The content of WSS information

No.	Items	Output	
		0	1
b <sub>1</sub>	Reference signal	–	1
b <sub>2</sub>	Reference signal	0	–
b <sub>3</sub>	Aspect ratio <sup>(1)</sup>	4:3 full format	16:9 letterbox
b <sub>4</sub>	Even parity bit for b <sub>3</sub> to b <sub>5</sub>		
b <sub>5</sub>	Reserved	0	–
b <sub>6</sub>	Field type <sup>(2)</sup>	First field	Next field
b <sub>7</sub>	Frame type	Reference frame	Other frame
b <sub>8</sub>	Vertical temporal helper	No	Yes
b <sub>9</sub>	Vertical high resolution helper	No	Yes
b <sub>10</sub>	Horizontal helper	No	Yes
b <sub>11</sub>	Horizontal helper pre-combing	No	Yes
b <sub>12</sub> to b <sub>13</sub>	Assigned for use in TV broadcasting stations		
b <sub>14</sub>	Assigned for use in TV broadcasting stations (should be set to “0” for output)	0	–
b <sub>15</sub> to b <sub>17</sub>	Reserved	0	–
b <sub>18</sub> to b <sub>23</sub>	Error correction codes for b <sub>3</sub> to b <sub>17</sub> <sup>(3)</sup>		
b <sub>24</sub>	Reference signal	0	–
b <sub>25</sub> to b <sub>27</sub>	Confirmation signal (sine wave)		

(1) If any of outputs b<sub>8</sub> to b<sub>10</sub> are “Yes”, b<sub>3</sub> shall be set to “1”.

(2) b<sub>6</sub> may not be used as a field type. In such a case, the output shall be set to “0”.

(3) These 6 data bits shall be Cyclic Redundancy Check (CRC) codes belonging to b<sub>3</sub> to b<sub>17</sub>. The generator polynomial  $G(x)$  shall be:  $G(x) = x^6 + x + 1$ .

## APPENDIX 1

## TO ANNEX 1

**Recommended practices****1 Pre-filtering for input signal sources**

For the input signal sources such as 525/59.94/1:1 and 1125/60/2:1, vertical pre-filtering for high frequency component reduction is desirable before EDTV-II encoding.

**2 Pre-combing in the horizontal helper (HH) multiplexing**

It is desirable that the luminance signal,  $Y$ , HH and colour difference signals,  $I$ ,  $Q$  are pre-combed before being multiplexed, because HH is multiplexed in the hole which is conjugate to the chrominance signal,  $C$ , in the vertical-temporal frequency domain, as shown in Fig. 16. Figure 17 shows an example of the block diagram for HH multiplexing with pre-combing. Figure 18 shows an example of pre-combing filter characteristics.

FIGURE 16

**Relation between chrominance signal and HH  
in three dimensional frequency spectrum**

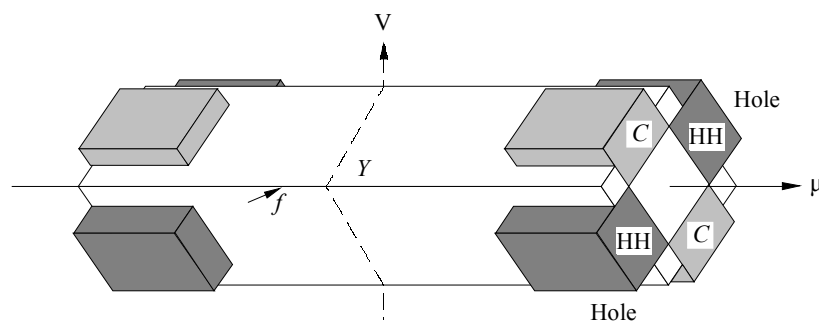

1298-16

FIGURE 17

An example of the block diagram for HH multiplexing with pre-combing

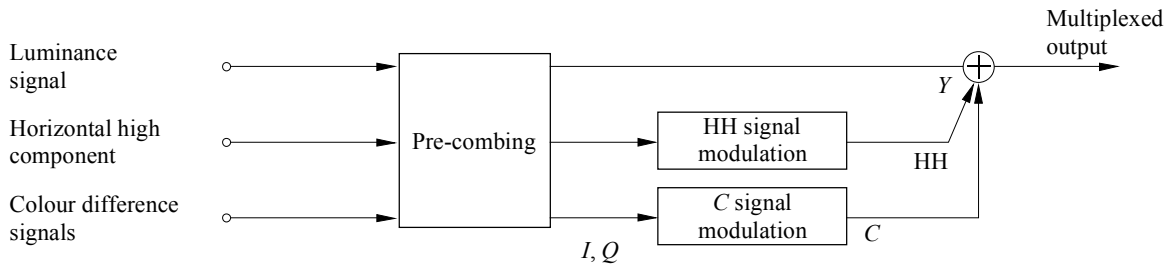

1298-17

FIGURE 18

An example of pre-combing characteristics  
(The dotted line defines the band pass areas)

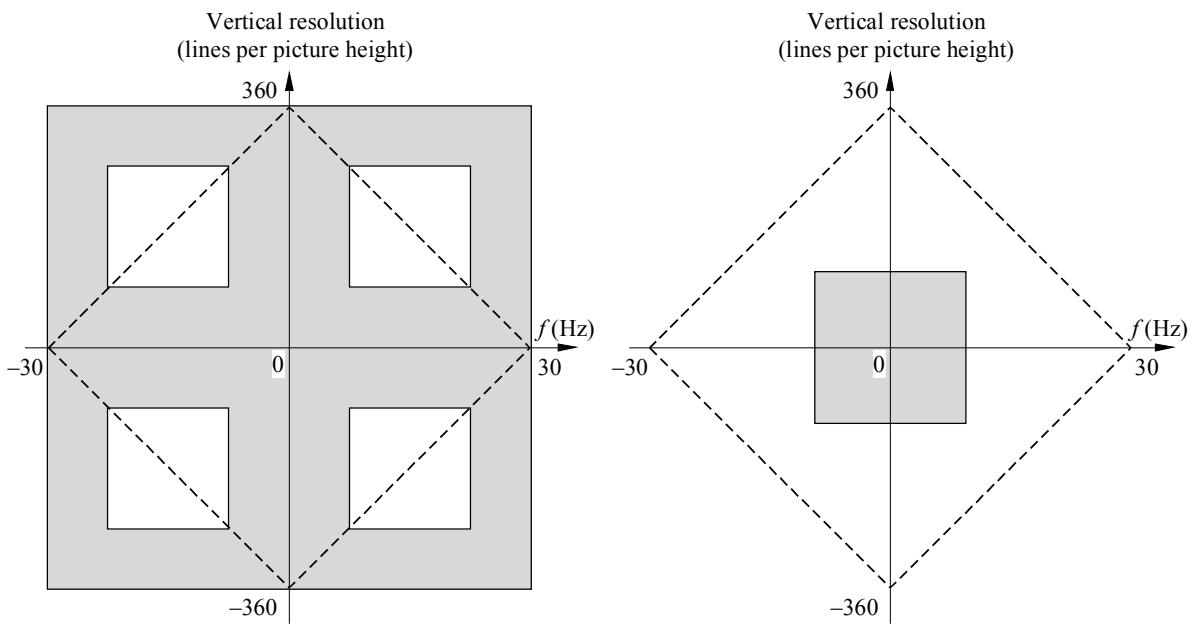

1298-18