

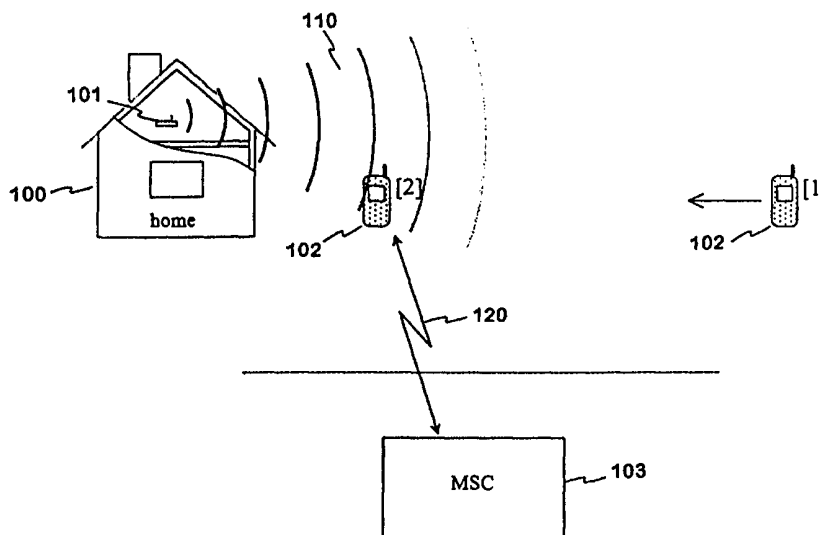

INTERNATIONAL APPLICATION PUBLISHED UNDER THE PATENT COOPERATION TREATY (PCT)

<p>(51) International Patent Classification ⁷ : H04Q 7/38</p>	<p>A1</p>	<p>(11) International Publication Number: WO 00/27152 (43) International Publication Date: 11 May 2000 (11.05.00)</p>
<p>(21) International Application Number: PCT/FI99/00908 (22) International Filing Date: 29 October 1999 (29.10.99) (30) Priority Data: 982365 30 October 1998 (30.10.98) FI (71) Applicant (for all designated States except US): NOKIA MOBILE PHONES LIMITED [FI/FI]; Keilalahdentie 4, FIN-02150 Espoo (FI). (72) Inventors; and (75) Inventors/Applicants (for US only): VIMPARI, Markku [FI/FI]; Kuovitie 14, FIN-90540 Oulu (FI). KOKKONEN, Jari [FI/FI]; Lautatie 17 B 21, FIN-90800 Oulu (FI). (74) Agent: OULUN PATENTTITOIMISTO BERGGREN OY AB; Teknologiantie 14 C, FIN-90570 Oulu (FI).</p>	<p>(81) Designated States: AE, AL, AM, AT, AU, AZ, BA, BB, BG, BR, BY, CA, CH, CN, CR, CU, CZ, DE, DK, DM, EE, ES, FI, GB, GD, GE, GH, GM, HR, HU, ID, IL, IN, IS, JP, KE, KG, KP, KR, KZ, LC, LK, LR, LS, LT, LU, LV, MD, MG, MK, MN, MW, MX, NO, NZ, PL, PT, RO, RU, SD, SE, SG, SI, SK, SL, TJ, TM, TR, TT, TZ, UA, UG, US, UZ, VN, YU, ZA, ZW, ARIPO patent (GH, GM, KE, LS, MW, SD, SL, SZ, TZ, UG, ZW), Eurasian patent (AM, AZ, BY, KG, KZ, MD, RU, TJ, TM), European patent (AT, BE, CH, CY, DE, DK, ES, FI, FR, GB, GR, IE, IT, LU, MC, NL, PT, SE), OAPI patent (BF, BJ, CF, CG, CI, CM, GA, GN, GW, ML, MR, NE, SN, TD, TG).</p> <p>Published <i>With international search report. Before the expiration of the time limit for amending the claims and to be republished in the event of the receipt of amendments.</i></p>	

(54) Title: METHOD AND ARRANGEMENT FOR LOCATING A MOBILE STATION



(57) Abstract

The invention relates to a method and arrangement for locating a mobile station. By means of the invention, it is detected whether said mobile station is located in a predetermined area. The basic idea of the invention is as follows. In the home and/or possibly in some other permanent location of residence, there is installed a transmitter (101), repeatedly transmitting the identity code of said mobile station. The transmission power is so low that the signal can only be detected within the range of a few tens of meters, for example. The signal is formed so that it can be distinguished from other possible signals active in the same area. A mobile station that detects its own identity code in the channel used by the transmitter sends a signal message to the mobile system. The message notifies that the mobile station is in the predetermined area. The system (103) advantageously utilises this information so that at least for those connections originated from said mobile station, there is set a lower tariff than in a case where the mobile station is out of reach of said transmitter (transmitters).

FOR THE PURPOSES OF INFORMATION ONLY

Codes used to identify States party to the PCT on the front pages of pamphlets publishing international applications under the PCT.

AL	Albania	ES	Spain	LS	Lesotho	SI	Slovenia
AM	Armenia	FI	Finland	LT	Lithuania	SK	Slovakia
AT	Austria	FR	France	LU	Luxembourg	SN	Senegal
AU	Australia	GA	Gabon	LV	Latvia	SZ	Swaziland
AZ	Azerbaijan	GB	United Kingdom	MC	Monaco	TD	Chad
BA	Bosnia and Herzegovina	GE	Georgia	MD	Republic of Moldova	TG	Togo
BB	Barbados	GH	Ghana	MG	Madagascar	TJ	Tajikistan
BE	Belgium	GN	Guinea	MK	The former Yugoslav Republic of Macedonia	TM	Turkmenistan
BF	Burkina Faso	GR	Greece			TR	Turkey
BG	Bulgaria	HU	Hungary	ML	Mali	TT	Trinidad and Tobago
BJ	Benin	IE	Ireland	MN	Mongolia	UA	Ukraine
BR	Brazil	IL	Israel	MR	Mauritania	UG	Uganda
BY	Belarus	IS	Iceland	MW	Malawi	US	United States of America
CA	Canada	IT	Italy	MX	Mexico	UZ	Uzbekistan
CF	Central African Republic	JP	Japan	NE	Niger	VN	Viet Nam
CG	Congo	KE	Kenya	NL	Netherlands	YU	Yugoslavia
CH	Switzerland	KG	Kyrgyzstan	NO	Norway	ZW	Zimbabwe
CI	Côte d'Ivoire	KP	Democratic People's Republic of Korea	NZ	New Zealand		
CM	Cameroon	KR	Republic of Korea	PL	Poland		
CN	China	KZ	Kazakistan	PT	Portugal		
CU	Cuba	LC	Saint Lucia	RO	Romania		
CZ	Czech Republic	LI	Liechtenstein	RU	Russian Federation		
DE	Germany	LK	Sri Lanka	SD	Sudan		
DK	Denmark	LR	Liberia	SE	Sweden		
EE	Estonia			SG	Singapore		

Method and arrangement for locating a mobile station

5 The invention relates to a method and arrangement for locating a mobile station. By means of the invention it is observed whether the mobile station is located in a predetermined area. The invention is advantageously applied for defining call tariffs, or for defining available services on the basis of the location of the mobile station in question.

10 Usually the costs of fixed wireline local calls are fairly moderate in comparison with similar connections by mobile phone, from the subscriber's home or from some other predetermined place. If the mobile system could know when the call has originated from the subscriber's home, lower tariffs could be applied in said connections without cutting the overall rates. Thus a mobile phone operator could more effectively compete of customers with fixed wireline operators also as regards
15 local calls. Mobile phone customers would also benefit. Moreover, operators could offer special services that are available only when the subscriber is "at home". A necessary requirement for the use of the above described applications is that the location of a mobile phone at home or in some other predetermined place can be accurately detected.

20 The accuracy of the localisation methods belonging to the basic functions of cellular networks is not sufficient with respect to the above mentioned applications. By means of roaming it is found out where the mobile phone is located at each particular moment - in which operator's network and in which location area. On the basis of paging, the location of the mobile station is found out more accurately, but
25 only on the accuracy level of one cell.

In the prior art, there are known the following methods for further improving the localisation of a mobile station:

- Location calculation. Methods are being developed for digital networks, by means of which the location of the mobile station is defined, on the basis of the transfer
30 times of the transmitted messages, for instance at the accuracy of 150 meters. The method offers a more specified localisation within the area of the whole network, and it is mainly designed in order to make help arrive more quickly in emergency situations. A drawback, as regards the objects of the present invention, is that even this accuracy is insufficient for finding out whether the mobile station is "at home."
35 Another drawback is the technically challenging nature of the system.

- The use of a HBS (Home Base Station): A mini base station is installed at home or in another desired location. Thus a sufficiently accurate localisation is made possible within the normal paging method. A drawback with this method is the remarkably high purchase or rental price for the subscriber - the home base station is private by nature. From the point of view of the operator, a drawback arises by the remarkable expenses caused by configuring the radio network.

- The use of a fixed telephone stand. At home, the mobile phone is set in a telephone stand provided with an individual SIM (Subscriber Identity Module) containing subscriber data. When the phone handset attached to the stand is used for making calls, the mobile network knows that the mobile phone is at home and applies a lower call tariff according to the data recorded in the SIM module of the stand. A drawback with this method is the fixed location of the phone.

The object of the invention is to eliminate some of the drawbacks of the prior art by creating a completely new solution, where the location of a mobile station within a determined area can be detected accurately, reliably and by means of fairly simple devices.

The basic idea of the invention is as follows: in the home and/or possibly in some other fixed place of residence, there is installed a transmitter which repeatedly transmits the identity code of said mobile station. The transmission power is so low that the signal is detected for example within a range of a few tens of meters only. The signal is formed so that it can be distinguished from other signals that are active within the same area. This is advantageously realised by applying code division multiplexing. A mobile station that detects its own identity code in the channel used by the transmitters sends a signal message to the mobile system. The message announces that the mobile station is "at home". The system advantageously uses this information so that at least for the mobile originated calls there is set a lower tariff than when the mobile station is outside the range of said transmitter (transmitters).

An advantage of the invention is that the location of the mobile station in a given place can be detected by means of an arrangement which does not cause technical problems in the network nor expenses connected thereto. Another advantage of the invention is that the required facility equipment is simple and thus economical in manufacturing/purchasing costs. Yet another advantage of the invention is that when the mobile station is located at home, all calls directed thereto can, when desired, be automatically transferred to the fixed wireline telephone. Moreover, it is an

advantage of the invention that in a certain mode, it can be provided with a function common to all mobile stations, such as switching the phone off in an aeroplane.

From the network operator's point of view, the invention brings forth the advantage that there opens up a practical possibility to compete of customers who have a
5 traditional fixed wireline telephone; from the the mobile station subscriber's point of view the advantage of the invention is that the operation costs of the mobile station are cut down due to cheaper home calls. Yet another advantage is that the cheaper home calls can be made without having to use the fixed wireline telephone.

The method according to the invention for locating a mobile station, in which
10 method the location of the mobile station within a predetermined home area is detected, and information of said location is sent to the mobile system, is characterised in that

- within said home area, using a guide channel, there is repeatedly transmitted the identity code of said mobile station,
- 15 - said mobile station monitors the guide channel,
- from said mobile station, there is sent a home message to the mobile network, if said identity code is detected, and
- the validity of the unit transmitting said identity code is verified.

The arrangement according to the invention for locating a mobile station, said
20 arrangement comprising means for detecting whether the mobile station is located within a predetermined home area, and means for sending the detected information to the mobile system, is characterised in that

- the means for detecting whether the mobile station is located within its home area comprise a guide unit installed in the home area and repeatedly transmitting the
25 identity code of said mobile station, as well as in the mobile station reception circuits corresponding to the channel that the guide unit uses for transmission, and means for processing the signal from the guide unit,
- the means for sending said detected information to the mobile system comprise in
30 the mobile station a program for formulating a home message and a mobile message, and

- the arrangement for locating the mobile station also comprises means for verifying the validity of said guide unit.

A few preferred embodiments of the invention are presented in the dependent claims.

5 In the following specification, the invention is explained in more detail with reference to the appended drawings, where

figure 1 illustrates the principle of the invention and an example of an arrangement according to it,

10 figure 2 is a flow diagram illustrating an example of the operation of an arrangement according to figure 1,

figure 3 illustrates another example of the arrangement according to the invention,

figure 4 is a signalling diagram illustrating an example of the arrangement according to figure 3,

15 figure 5 is a block diagram illustrating an example of the guide unit according to the invention,

figure 6 is a block diagram illustrating another example of the guide unit according to the invention, and

20 figure 7 is a block diagram illustrating an example of a mobile station according to the invention.

In figure 1, we see an example of the arrangement according to the invention. Operational units are the guide unit 101, the mobile station 102 and the MSC, mobile switching centre 103. The guide unit 101 includes a radio transmitter. The guide unit is installed permanently in the premises 100, and it is realised so that the unit stops operating, if it is detached and moved. The unit 101 repeatedly transmits the identity code of the mobile station 102, which code can be for instance the IMEI (International Mobile station Equipment Identity) of the mobile station. The transmission power is so low that the field 110 of said radio transmitter extends in detectable form only to the premises 100 and to the immediate vicinity thereof. The area where the mobile station identity code can be detected is in the specification and in the appended claims called the home area of said mobile station. The "home

25
30

area" can be the subscriber's home or summer cottage with surroundings, working place or some other defined area. The channel on which the guide unit sends the mobile station identity code is in this specification and claims called guide channel, irrespective of the applied technology.

- 5 In order to illustrate the principle of the invention, let us observe a situation where the mobile station 102 is first located in a place [1], where the field strength of the guide unit 101 is in practice zero. Then the mobile station is transferred to another place [2], where the field 110 of the guide unit is observed and the signal contained therein detected. Now the mobile station identifies its own identity code in the
- 10 signal from the guide unit and transmits, by using the network signalling connection 120, to the mobile switching centre 103 a message that it is located in the home area. Thereafter the calls originated from the mobile station 102 are billed according to a tariff that is lower than before the mobile station entered the home area. The mobile switching centre 103 maintains the lower tariff until the mobile station 102
- 15 indicates that it is located outside the range of the guide unit 101, or when the base station connection of the mobile station is interrupted. Lower tariffs can also be applied for incoming calls to the mobile station 102, so that the mobile switching centre 103 notifies that switching centre which has the information of the paying customer that the called mobile station is located in its home area.
- 20 Figure 2 is a flow diagram of a method according to the invention. In step 201, the operating voltage of the mobile station is switched on. In step 202, the mobile station observes in idle mode the frequency division channel, i.e. the guide channel, reserved for transmitting the identity codes. This channel is advantageously the first or last channel in the frequency area reserved for said mobile network, because
- 25 these are normally left unused as traffic channels owing to possible interference. However, in the usage according to the invention the transmission powers in said channel are so low that there is no danger of interference. The observation of the guide channel here means that the mobile station receiver is tuned to the channel and the detector output is observed. From the detector output, there is searched, in
- 30 step 203, a signal to be synchronised with. If such a signal is detected, the identity code connected thereto is decoded in step 204. Separate guide units meant for different mobile stations but using the same guide channel can be located fairly near to each other. In order to distinguish between the various identity codes, the guide signals must be further channelled in the guide channel. In theory, the same time
- 35 division technique could be applied as in other frequency division channels of said digital network, but the system would become unreasonably complicated and

expensive. It is, however, advantageous to apply in the guide units CDM (Code Division Multiplexing) or frequency hopping. In the latter case, the carrier wave frequency is arranged to fluctuate according to a sequence formed of the numbers of the identity code. When applying code division multiplexing, for instance each bit
5 of the identity code is represented by a given codeword, which is sent in identical or inverted order depending on whether said databit is one or zero. First the receiving mobile station processes the received signal, by means of correlation technique, into the datasignal proper, and thereafter compares the code contained therein to its own identity code in step 205. If the mobile station is not located in its home area, the
10 correlator does not give the signal containing the information, at least not the identity code of said mobile station. Code division multiplexing is suited to be applied in analog mobile networks, too.

If the mobile station has detected its own identity code, it sends to the network a message to that effect in step 206. In the case of a GSM network, the transfer can
15 take place for example in the RACH (Random Access CHannel) or in the SACCH (Slow Associated Control Channel). Let us call said message here and in the claims "home message". When a home message has arrived in the mobile switching centre, the centre program sets lower tariffs for said mobile station, step 207. In proportion, the discount is most remarkable when making local calls. The mobile station
20 announces on the display and possibly by sound signal that the tariffs are lowered. As long as the mobile station is located in its home area, it continues to observe the guide channel in step 208. As long as a signal is detected in the guide channel, and said signal contains the identity code of said mobile station, the mobile station does not do anything new in this respect, steps 208-211. If, on the contrary, a signal is
25 not detected in the guide channel, or a signal is detected, but the identity code of said mobile station is not found therein, a new message is sent to the network in steps 209-212. Let us call this second message here and in the claims a "mobile message". When the mobile message has arrived in the mobile switching centre, the program returns to normal tariffs for said mobile station, step 213. Normal tariffs
30 are returned also if the mobile station is switched off, or if its connection to the base station is interrupted for some other reason. When the mobile station has moved to outside its home area (step 212), it further proceeds to search for its identity code according to the above described steps 202-205. The verification of the appearance and disappearance of the identity code can be arranged in a secured manner, so that
35 when the mobile station is located at the borders of its home area, unnecessary signalling traffic in the network is avoided. This type of hysteresis is not illustrated in figure 2.

Figure 3 illustrates another example of the arrangement according to the invention. It includes a guide unit 301, comprising an infrared transmitter/receiver, and a mobile station, likewise comprising an infrared transmitter/receiver. In this example, the guide unit 301 is installed in the ceiling of the room 300 which serves as the place of residence of the subscriber 350 of the mobile station 302. The unit 301 repeatedly transmits the identity code of the mobile station 302. In the situation of figure 3, the person 350 has stepped in the room 300 and directed the infrared window of the mobile station 302 towards the guide unit 301. Now there is created a two-way infrared connection 310 between the mobile station and the guide unit. In the guide unit signal, the mobile station 302 identifies its own identity code and sends, by using the network messaging connection 320, notice to the mobile switching centre that it is located in its home area. On the basis of said notice, the mobile switching centre for instance lowers tariffs according to the description above.

Figure 4 is a signalling diagram illustrating the operation of a system according to figure 3. The guide unit transmits repeatedly the identity code of the mobile station belonging thereto. In step 401, the mobile station is located outside its home area, in other words outside the reach of the infrared signal of the guide unit. In step 402, the mobile station has been brought to its home area, and in the infrared message it identifies its own identity code. As a consequence, it transmits a home message to the network. When the home message arrives in the mobile switching centre, the centre transmits to the mobile station a random number per each individual case. Said random number is further sent by the mobile station to the guide unit via the infrared link. In this example, the guide unit is provided with its own SIM module, which contains a secret identity number for verifying the validity of the unit. In step 403, the guide unit calculates, according to a given algorithm, a response number on the basis of said secret identity number and said random number, and it sends the obtained response number to the mobile station. The mobile station further sends the response number to the mobile switching centre, which compares the received response number with the one that was earlier calculated in the centre. If the numbers match, the centre for example sets lower tariffs for said mobile station and sends a notice to that effect for the mobile station. At suitable intervals, the mobile station reads the signal transmitted by its infrared receiver. In step 405, the mobile station has not within a predetermined period of time detected its own identity code, and it sends a mobile message to the centre. In the acknowledge message, the centre notifies that normal tariffs are applied again.

Figure 5 shows an example of the guide unit. The guide unit 500 comprises a memory 510, a digital to analog converter 520, a transmitter unit 530, an antenna 531, a control unit 540, a small keyboard 541, a frequency unit 550 and an oscillator 551. In the memory 510, there are recorded recalculated bit patterns, which, when
5 fed in the converter 520 at the right speed, produce the baseband analog signals I and Q conforming to the modulation mode used in said mobile network. Thus the converter 520 contains two separate DA converters, one for the I signal and the other for the Q signal. For example in the case of a GSM network, the signals I and Q conform to the modulation GMSK (Gaussian Minimum Shift Keying). In the
10 transmission unit, the signals I and Q affect directly for instance in the quadrature carrier waves, or first in the quadrature sine waves with the intermediate frequency. In both cases, there is formed a summed radio frequency signal which is then amplified in the radio transmitter proper and fed to the antenna 531.

The picking of the numbers from the memory 510 takes place so that the control
15 unit 540 sends, at regular intervals, successive addresses and a number control signal to the memory. Each memory location contains two numbers, the first of which corresponds to the momentary state of the I signal, and the second corresponds to the momentary state of the Q signal. The parallel numbers are fed to the converter 520, as was explained above. The control unit 540 also sends a timing
20 signal to the converter 520 and a frequency setting signal to the frequency unit 550. In order to manually choose the carrier wave, the guide unit is provided with a small keyboard 541, for example. The frequency unit 550 creates the waves with the necessary frequency advantageously by applying phase lock technique, by utilising the basic frequency wave transmitted by the oscillator 551.

25 Figure 6 illustrates an example of an guide unit applying frequency hopping. The guide unit 600 includes a control unit 610, a frequency unit 620, and oscillator 621, a transmission unit 630 and an antenna 631. In the control unit, there is recorded the individual code id of the mobile station, which is for instance suitably shortened as IMEI. The control unit 610 sends, as a repeated sequence, the numbers of the code
30 id to the frequency unit 620. This in turn forms, by using the basic-frequency wave transmitted by the oscillator 621, a radio-frequency signal with a fluctuating or "hopping" frequency in correspondence to the numbers obtained from the control unit. In this case, the frequency fluctuation range falls outside the frequency bands used by mobile networks, in some free frequency area. The frequency hopping
35 signal sent by the frequency unit 620 is fed into the transmission unit 630, which feeds it, filtered and amplified, to the antenna 631.

Figure 7 is a block diagram showing an example of a mobile station according to the invention. The mobile station 700 comprises a SIM card 710 for storing user data. The transmission apparatus comprises, in this order, a microphone 731, a speech coder 732, a channel processor 733 and a transmitter unit 734. In the speech coder 5 732, the voice signal is digitised and compressed. In the channel processor 733, the speech or data signal to be transmitted is channel coded, the bit sequences are interleaved, a possible encryption takes place and the bursts to be located in the system time slots are created. In the transmitter unit 734, there is carried out modulation, the formation of radio frequency signal and setting of the level. The receiver apparatus includes, in this order, a receiver unit 744, a receiver side 10 channel processing apparatus 743, a speech decoder 742 and a earphone 741. In the receiver unit 744, there is carried out, among others, tuning to the reception channel and demodulation. In the processing apparatus 743, there are carried out inverted operations as compared to the operations of the channel processor 733, and in the 15 speech decoder 742 as compared to the operations of the speech coder 732. In common, the transmission and reception arrangements have the antenna 750 and the duplex filter 751 coupled thereto.

In order to operate the mobile station 700, it is provided with a keyboard 761 and a display 762. In order to control the operations, the mobile station includes a control 20 unit 720. Said control unit feeds the message and other data signals to the channel processor 733, as well as receives signals of the same type from the channel processing apparatus 743. The intercommunication of the control unit with the rest of the units takes place via the path 780. The control unit 720 includes a memory 721, where there is stored the software PR required by the mobile phone operations 25 according to the invention. The software PR at least creates the home and mobile messages to be sent in the network. The comparison of the identity code sent by the guide unit can be carried out by means of the PR software, or then by the device itself, in the control unit 720. If the mobile station verifies the validity of the guide unit, the software PR comprises the programme part of the verification process.

30 Figure 7 does not include some of the additions required by a few preferred embodiments in mobile station. The use of code division multiplexing does not require additions in the hardware. If the guide unit operates according to the frequency hopping principle, there are needed, in the mobile station, receiver devices which can be tuned to the frequency range used in the frequency hopping, 35 and which send a code corresponding to the hopping sequence. If infrared technique

is used in the guide unit, naturally the mobile station also must be provided with an infrared unit with transmitter and receiver.

In the above specification, we have described a few preferred embodiments according to the invention. However, the invention is not restricted to them alone.

5 For example, the identity code can also be transmitted by means of a fairly wide conductor loop. The validity of the guide unit applying radio frequencies can also be verified according to the procedure described in figure 4. The validity of the guide unit of any possible type can also be verified in a simpler fashion, directly in the mobile station, by using the secret identity code in the calculation. When using the

10 invention particularly for defining the price/service connected to the phone call, the mobile station can check its location only when making a call and possibly when receiving one. If the checking proves the device to be in the home area, the mobile switching centre can for instance set lower tariffs for the duration of said call, and cancel the discount when the call is terminated. The inventive idea can be applied in

15 many different ways within the scope of the independent patent claims.

Claims

1. A method for locating a mobile station, in which method the location of the mobile station in a predetermined home area is detected, and the information of said location is fed into the mobile system, **characterised in that**
 - 5 - within said home area, into the guide channel there is repeatedly transmitted the identity code of said mobile station,
 - the guide channel is observed by said mobile station,
 - from said mobile station there is transmitted to the mobile network a home message, if said identity code is detected, and
 - 10 - the validity of the unit transmitting said identity code is verified.
2. A method according to claim 1, **characterised in that** the guide channel is the first or last frequency division channel in the frequency range reserved for said mobile network.
3. A method according to claim 1 or 2, **characterised in that** the guide channel
15 is divided for the use of various different mobile stations by means code division multiplexing (CDM).
4. A method according to any of the claims 1-3, **characterised in that** in the guide channel, there is applied an essentially lower power level than in the rest of the channels in said mobile network.
- 20 5. A method according to claim 1, **characterised in that** the guide channel is a frequency range located outside the frequency range reserved for said mobile network.
6. A method according to claim 5, **characterised in that** the guide channel is divided to be used by several mobile stations by applying frequency hopping.
- 25 7. A method according to claim 1, **characterised in that** the identity code is transmitted by encoding it in infrared radiation.
8. A method according to claim 1, **characterised in that** in order to verify the validity of the guide unit, i.e. the unit transmitting the identity code,
 - in said home message, there is included information as for the transfer of said
30 identity code in the mobile network channel, and
 - in the mobile system, there is read the notice regarding the home message.

9. A method according to claim 1, **characterised in that** in order to verify the validity of the guide unit,
- from the mobile system, there is transmitted to the guide unit a random number through said mobile station,
 - 5 - in the guide unit, there is calculated, according to a predetermined algorithm, a response number on the basis of said random number and a secret identity number,
 - the response number is transmitted, through said mobile station, to said system, and
 - the response number is compared in the system with the number calculated by the system.
10. A method according to claim 1, **characterised in that** in order to verify the validity of the guide unit,
- a random number is transmitted from the mobile station to the guide unit,
 - in the guide unit, there is calculated, according to a predetermined algorithm, a response number on the basis of said random number and a secret identity number,
 - 15 - the response number is transmitted to said mobile station, and
 - the response number is compared in the mobile station with the number calculated by said mobile station.
11. A method according to claim 1, **characterised in that** the guide channel is observed at regular intervals.
12. A method according to claim 1, **characterised in that** the guide channel is observed only in connection with an ongoing call.
13. A arrangement for locating a mobile station (102), said arrangement comprising means for detecting whether the mobile station is located in a predetermined home area, and means for transferring said information to the mobile system (103), **characterised in that**
- the means for detecting the location of the mobile station in the home area comprise a guide unit (101) arranged to repeatedly transmit the identity code of said mobile station, as well as in the mobile station (102), receiver circuits corresponding to the channel used by the guide unit for transmission and means for processing the signal received from the guide unit;
 - 25 - the means for transferring said detected data to the mobile system comprise in the mobile station a program (PR) for creating a home message and a mobile message, and
- 30

- the arrangement for locating the mobile station also includes means for verifying the validity of said guide unit.

14. A guide unit for locating a mobile station, **characterised in that** it comprises means for forming the signal containing the identity code of the mobile station, and
5 means for transmitting said signal in order to detect whether the mobile station is located in a predetermined home area defined by the range of the guide unit transmission signal.

15. A guide unit (500) according to claim 14, **characterised in that** the means for forming the signal containing the identity code of the mobile station are means for
10 converting said identity code into a code division multiplexed form, i.e. to a CDM form, and that the means for transmitting said signal comprise a transmission unit (530) in order to transmit said identity code to a given channel in the mobile network, as well as a frequency unit (550), which is arranged to create a carrier wave corresponding to at least the other border channel of the frequency range
15 reserved for said mobile network.

16. Means according to claim 15 for converting said identity code to CDM form, **characterised in that** they comprise
- a memory (510) containing numbers that correspond to samples extracted from baseband CDM-form signals suitable to said modulator,
20 - a digital to analog converter (520) for converting said numbers to signals (I, Q) to be transferred to the quadrature branches of said modulator, and
- a control unit (540) for reading said memory and for timing said digital to analog converter.

25 17. A transmission unit (530) according to claim 15, **characterised in that** it comprises a modulator and a radio transmitter conforming to the modulation method applied in said mobile network.

18. A guide unit (600) according to claim 14, **characterised in that** the means for forming the signal containing the identity code of the mobile station are means (610,
30 620) for forming a frequency hopping sequence corresponding to said identity code, and the means for transmitting said signal comprise a radio transmitter (630) arranged to use the frequency range outside the frequency range reserved for said mobile network.

19. A guide unit according to claim 14, **characterised in that** the means for transmitting the signal containing said identity code comprise an infrared transmitter, and that said guide unit also comprises an infrared receiver.
- 5 20. A guide unit according to claim 14, **characterised in that** there is recorded a secret identity code therein, and that it comprises means for calculating the response number used in verifying the validity of the guide unit, by using said secret identity code and the random number received from outside.
- 10 21. A mobile station (700), comprising data signal transmission, reception and processing units, **characterised in that** said mobile station also comprises means for observing the guide channel, and that said processing unit includes means for detecting the identity code of said mobile station from the signal transmitted by the guide channel, and means (PR) for forming a home message and/or a mobile message in order to be transmitted to the mobile system.

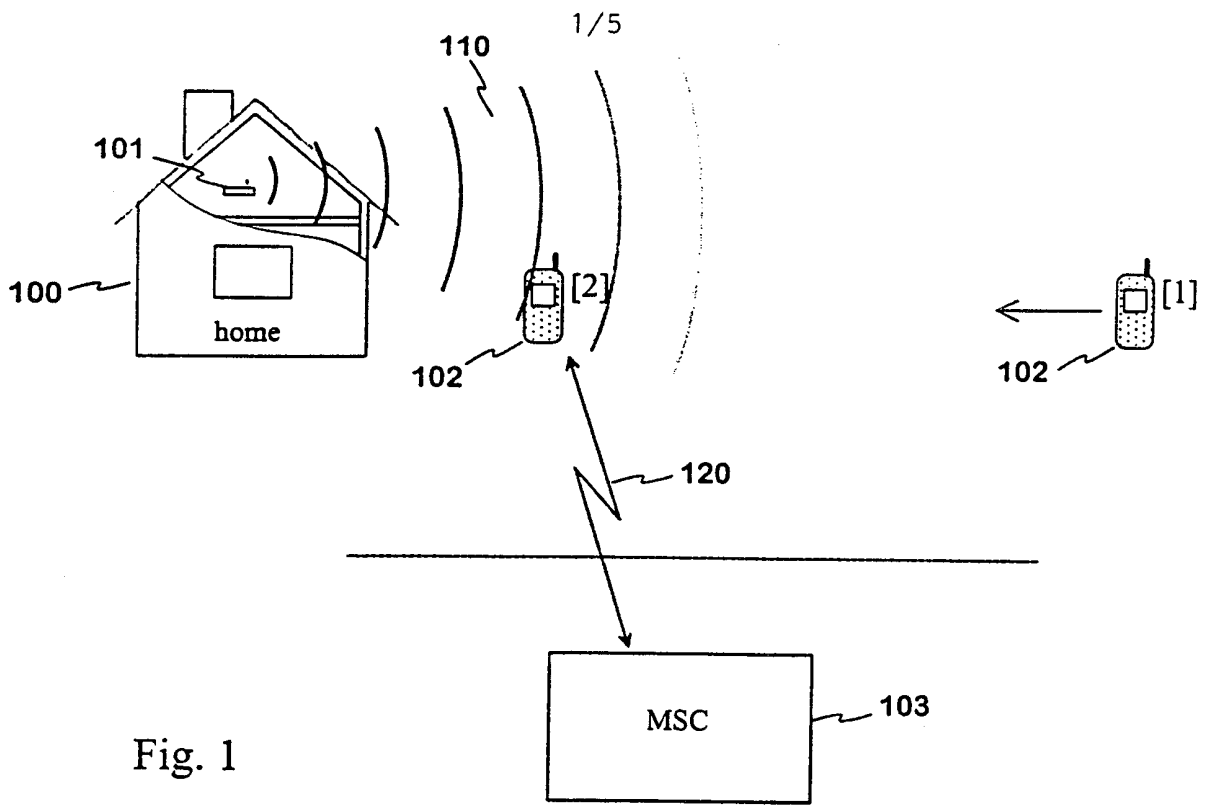

Fig. 1

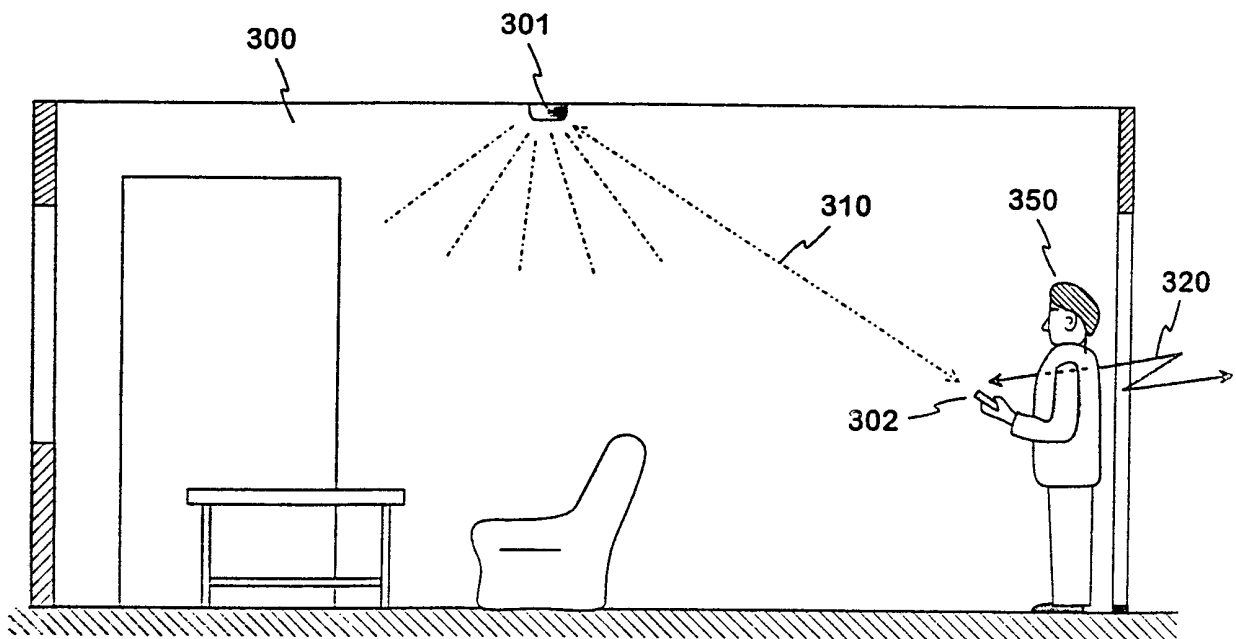

Fig. 3

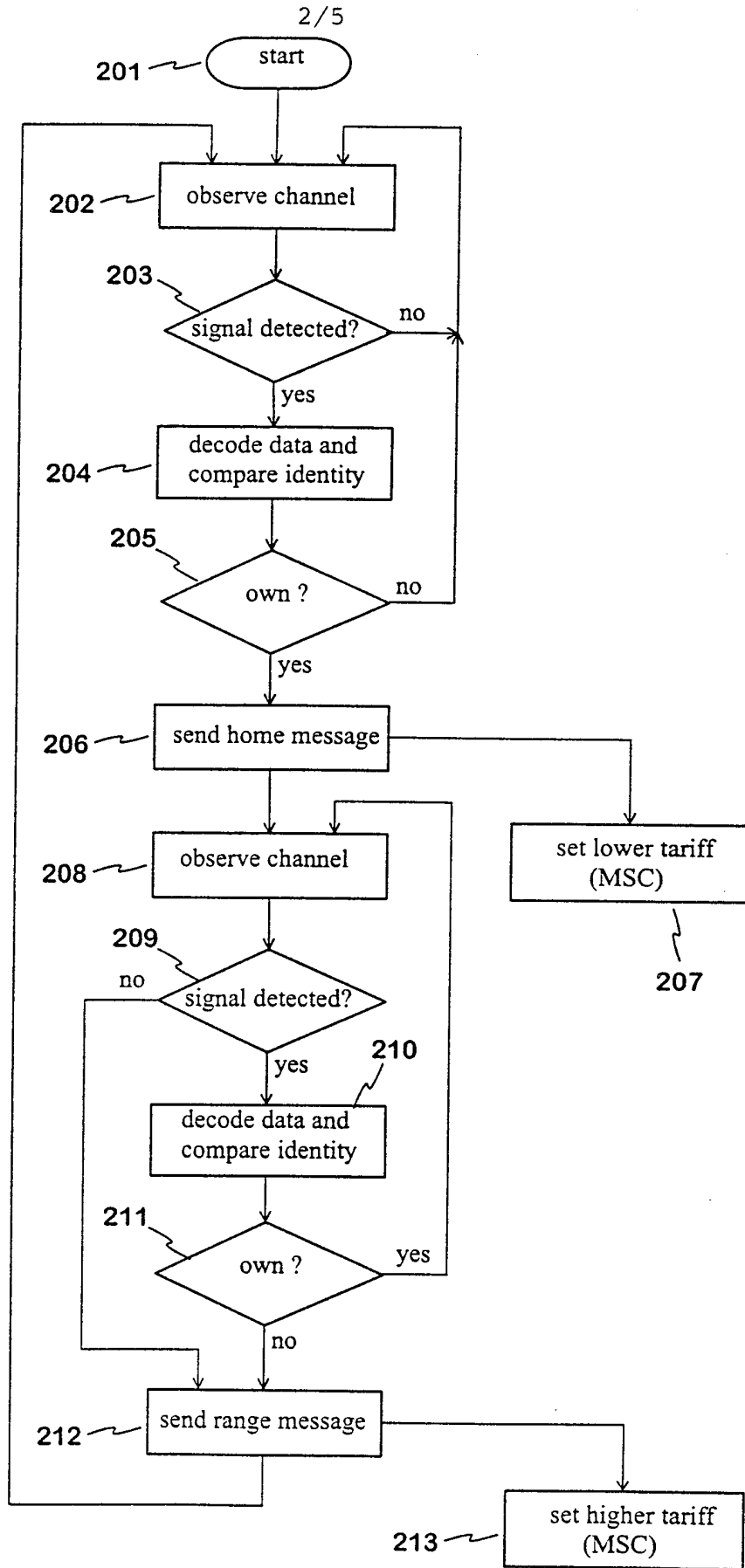

Fig. 2

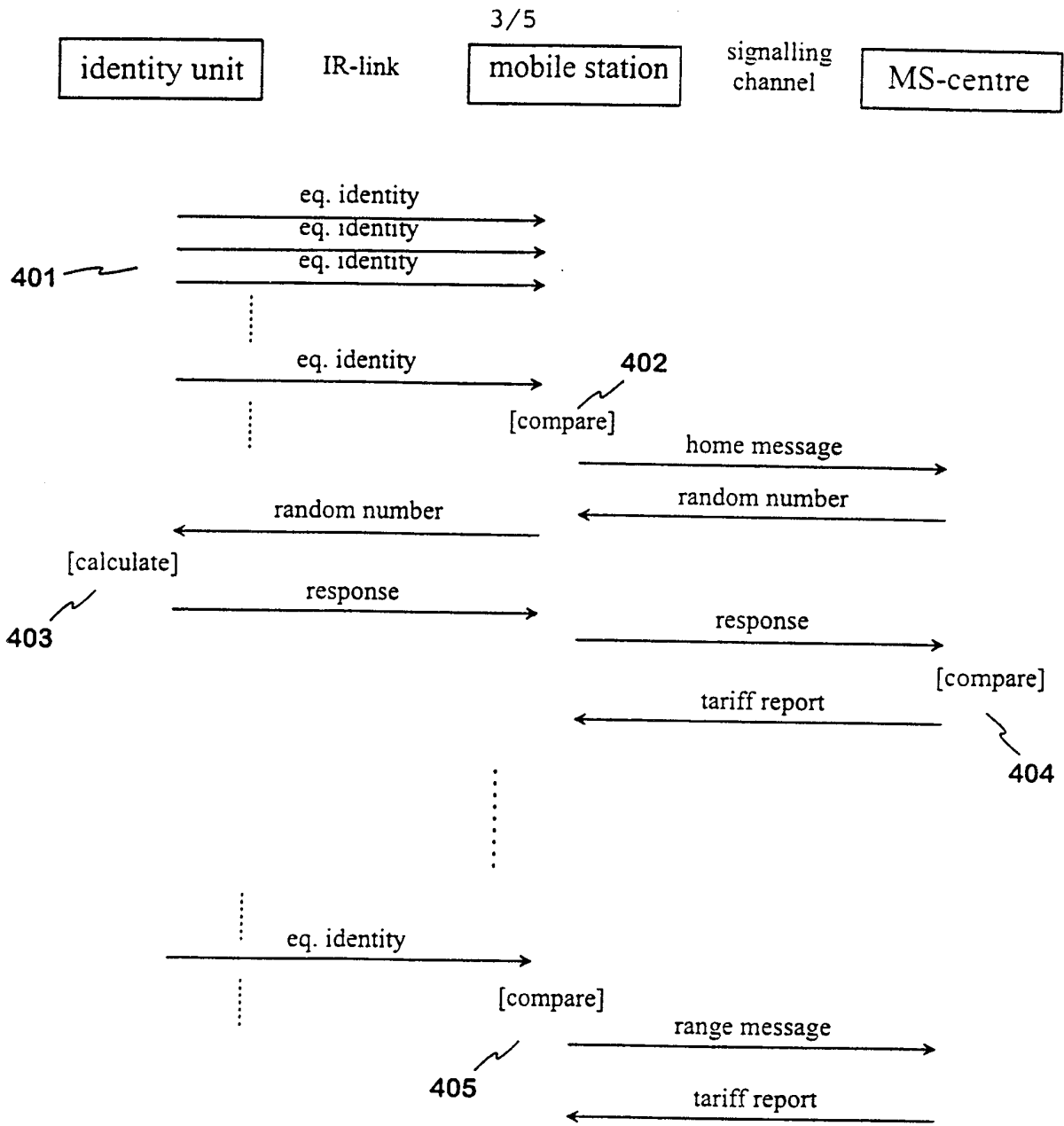

Fig. 4

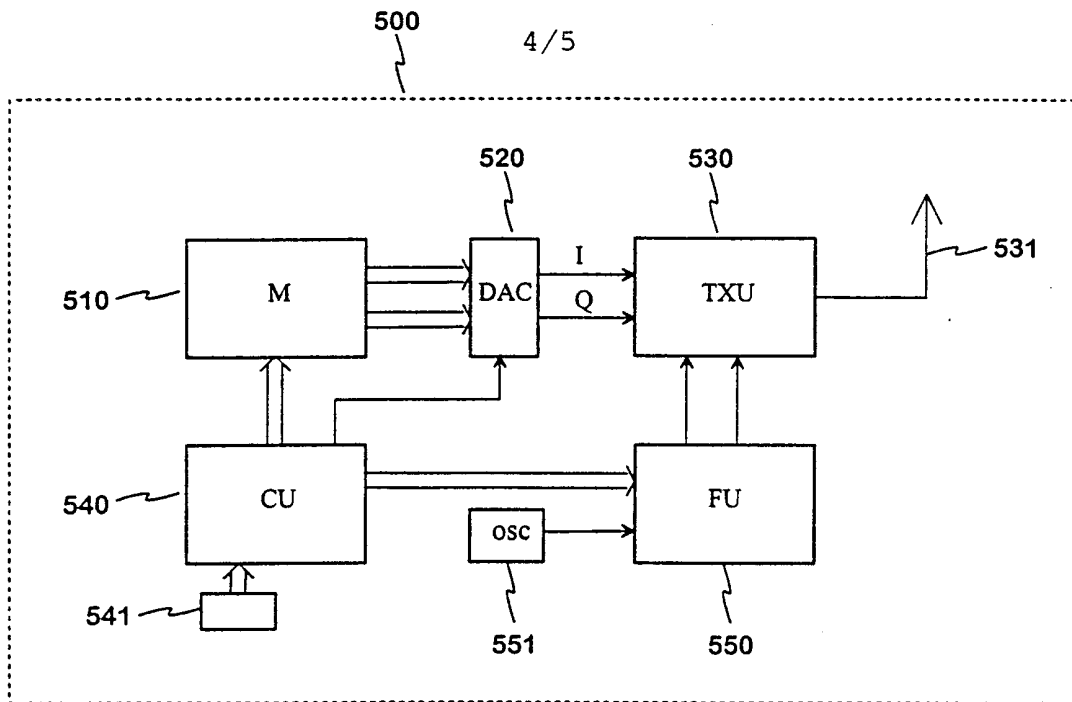

Fig. 5

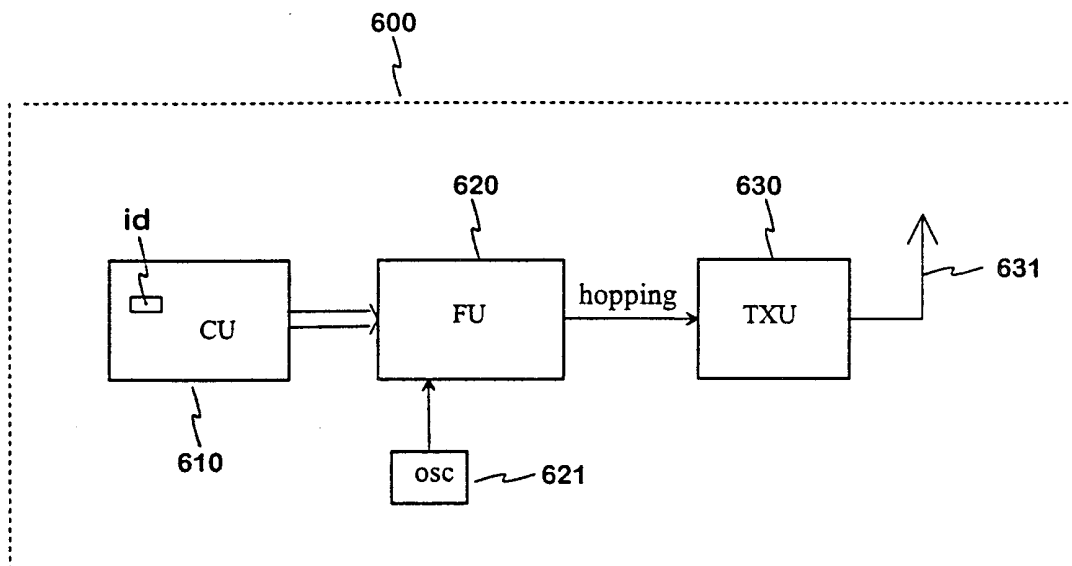

Fig. 6

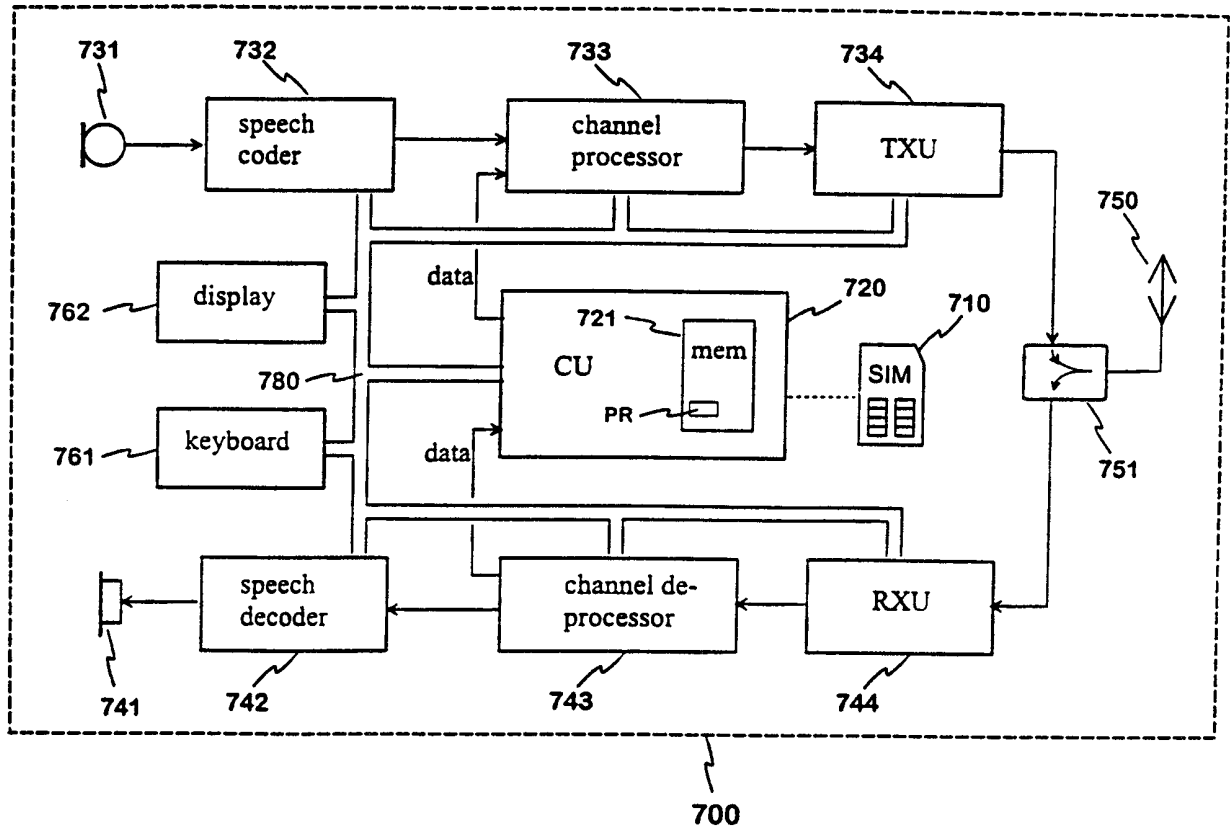

Fig. 7

INTERNATIONAL SEARCH REPORT

International application No.

PCT/FI 99/00908

A. CLASSIFICATION OF SUBJECT MATTER

IPC7: H04Q 7/38

According to International Patent Classification (IPC) or to both national classification and IPC

B. FIELDS SEARCHED

Minimum documentation searched (classification system followed by classification symbols)

IPC7: H04Q

Documentation searched other than minimum documentation to the extent that such documents are included in the fields searched

SE,DK,FI,NO classes as above

Electronic data base consulted during the international search (name of data base and, where practicable, search terms used)

C. DOCUMENTS CONSIDERED TO BE RELEVANT

Category*	Citation of document, with indication, where appropriate, of the relevant passages	Relevant to claim No.
P,A	WO 9911085 A1 (NOKIA MOBILE PHONES LTD.), 4 March 1999 (04.03.99) --	1-21
P,A	WO 9952316 A1 (NOKIA TELECOMMUNICATIONS OY), 14 October 1999 (14.10.99) --	1-21
X	CA 2195487 A (BUHRMANN, M.), 21 August 1997 (21.08.97), page 2, line 21 - line 28; page 6, line 17 - line 21, abstract	1,13,14,21
A	--	2-12,15-20

 Further documents are listed in the continuation of Box C.
 See patent family annex.

* Special categories of cited documents:

"A" document defining the general state of the art which is not considered to be of particular relevance

"E" earlier document but published on or after the international filing date

"L" document which may throw doubts on priority claim(s) or which is cited to establish the publication date of another citation or other special reason (as specified)

"O" document referring to an oral disclosure, use, exhibition or other means

"P" document published prior to the international filing date but later than the priority date claimed

"T" later document published after the international filing date or priority date and not in conflict with the application but cited to understand the principle or theory underlying the invention

"X" document of particular relevance: the claimed invention cannot be considered novel or cannot be considered to involve an inventive step when the document is taken alone

"Y" document of particular relevance: the claimed invention cannot be considered to involve an inventive step when the document is combined with one or more other such documents, such combination being obvious to a person skilled in the art

"&" document member of the same patent family

Date of the actual completion of the international search

13 March 2000

Date of mailing of the international search report

16 -03- 2000

Name and mailing address of the ISA/

Swedish Patent Office
Box 5055, S-102 42 STOCKHOLM
Facsimile No. +46 8 666 02 86

Authorized officer

Sven-Erik Bergdahl / MR
Telephone No. +46 8 782 25 00

INTERNATIONAL SEARCH REPORT

International application No.

PCT/FI 99/00908

C (Continuation). DOCUMENTS CONSIDERED TO BE RELEVANT

Category*	Citation of document, with indication, where appropriate, of the relevant passages	Relevant to claim No.
X	US 5444765 A (K. MARUI ET AL), 22 August 1995 (22.08.95), column 1, line 61 - line 67; column 2, line 26 - line 41; column 7, line 21 - column 8, line 28, figures --	1,13,14,21
X	US 5471643 A (K. MARUI), 28 November 1995 (28.11.95), the whole document	1,13,14,21
A	--	2-12,15-20
X	FR 2711033 A1 (COMPAGNIE FINANCIERE POUR LE RADIOTELEPHONE (COFIRA) (S.A.)), 14 April 1995 (14.04.95), page 1, line 11 - line 19, abstract	1,13,14,21
A	--	2-12,15-20
X	EP 0344989 A2 (KABUSHIKI KAISHA TOSHIBA), 6 December 1989 (06.12.89), the whole document	1,13,14,21
A	--	2-12,15-20
X	EP 0597638 A1 (VODAFONE LIMITED), 18 May 1994 (18.05.94), column 1, line 5 - line 24; column 2, line 4 - line 13; column 2, line 33 - line 54, abstract	1,13,14,21
A	--	2-12,15-20
X	EP 0783235 A2 (AT&T CORP.), 9 July 1997 (09.07.97), the whole document	1,13,14,21
A	-- -----	2-12,15-20

INTERNATIONAL SEARCH REPORT
Information on patent family members

02/12/99

International application No.
PCT/FI 99/00908

Patent document cited in search report	Publication date	Patent family member(s)	Publication date
WO 9911085 A1	04/03/99	AU 8864998 A EP 0915631 A FI 973456 A	16/03/99 12/05/99 23/02/99
WO 9952316 A1	14/10/99	FI 980654 D	00/00/00
CA 2195487 A	21/08/97	US 5950125 A	07/09/99
US 5444765 A	22/08/95	NONE	
US 5471643 A	28/11/95	CA 2035306 C JP 3226129 A	25/07/95 07/10/91
FR 2711033 A1	14/04/95	EP 0647076 A FR 2711023 A,B	05/04/95 14/04/95
EP 0344989 A2	06/12/89	SE 0344989 T3 CA 1318356 A DE 68912407 D,T JP 1300722 A JP 2854579 B US 5101500 A JP 1300723 A JP 2809641 B	25/05/93 11/05/94 05/12/89 03/02/99 31/03/92 05/12/89 15/10/98
EP 0597638 A1	18/05/94	AU 5056893 A GB 2272607 A	26/05/94 18/05/94
EP 0783235 A2	09/07/97	JP 9200836 A US 5740538 A	31/07/97 14/04/98