

# (12) Unexamined Patent Application Publication (A)

(19) Japan Patent Office

(11) Patent App. No.: H11-66930

(43) Disclosure Bulletin Date: March 9, 1999

(51) Int. Cl.6	ID Symbol	JPO Control No.	FI	Tech Display Location
F21V 8/00			F21V 8/00	M

Request for Examination: Not Requested

Number of Claims: 2 OL (4 Pages Total)

(21) Application Number: H9-216259

(22) Filing Date: August 11, 1997

(71) Applicant: 000138200

Moritex Corporation

3-1-14 Jingumae, Shibuya-ku, Tokyo

(72) Inventor: Shimizu, Masayuki

4767 Ohaza Tamagawa, Tamagawa-mura,

Hiki-gun, Saitama

(74) Representative: Sawano, Masafumi;

Attorney (and 1 other)

## (54) Name of Invention:

### Illumination Device

## (57) Abstract

**Topic:** To simplify the structure and eliminate the need for complex operations at the time of manufacture, to reduce manufacturing cost by decreasing the quantity of used optic fibers, and to obtain a ring-shaped uniform diffused illumination.

**Solution Means:** The light conducted into Casing (7) is made incident on ring-shaped Light Emitting Body (6) by reflecting it with Reflection Elements (10a, 10b) and thereby directing it onto Incident End Surfaces (6a, 6b) formed at both ends of the body. The light advancing through Light Emitting Body (6) is directed from Reflection Surface (6ref) formed at the Bottom Section (8a) side of Ring Channel (8) toward the Radiating Surface (6out) formed at the Opening Section (8b) side of Ring Channel (8), thereby undergoing diffusion reflection and being emitted to the exterior. Because the light is made incident from both Incident End Surfaces (6a, 6b) at this time, a drop in light intensity

Fig. 1

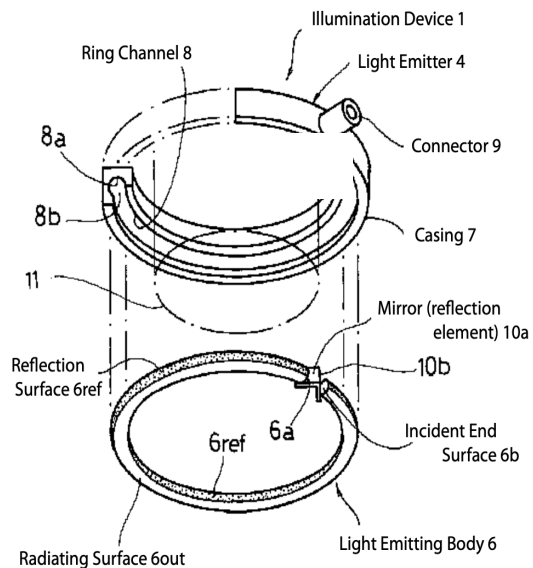

incident from one of Incident End Surfaces (6a, 6b) will be compensated by light incident from the other of Incident End Surfaces (6b, 6a), whereby the light is irradiated uniformly from Radiating Surface (6out). In addition, it is not necessary to route optic fiber within Ring Channel (8), thus enabling size reduction and simplification of Illumination Device (1).

## **Claims**

### **Claim 1:**

In an illumination device that provides a ring-shaped Light Emitter (4) for emanating the light conducted from a Light Source (2), an illumination device characterized by the Light Emitter (4) providing, within a Ring Channel (8) formed in Casing (7), a Light Emitting Body (6) formed in a ring shape with opposing Incident End Surfaces (6a, 6b) formed at both its ends at a prescribed interval and having the purpose of emanating from its peripheral surface to the exterior the light made incident on Incident End Surfaces (6a, 6b), and providing Reflection Elements (10a, 10b) between the Incident End Surfaces (6a, 6b) of Light Emitting Body (6) and having the purpose of reflecting onto Incident End Surfaces (6a, 6b) the light conducted into Casing (7), and by Light Emitting Body (6) being formed with its peripheral surface at the Bottom Section (8a) side of Ring Channel (8) formed into Reflection Surface (6ref) for causing diffusion reflection of the light advancing through Light Emitting Body (6) and directing it toward the Opening Section (8b) side of Ring Channel (8), and its peripheral surface at the Opening Section (8b) side of Ring Channel (8) formed into Radiating Surface (6out) for emitting to the exterior the light reflected by Reflection Surface (6ref).

### **Claim 2:**

In an illumination device comprising a Light Guide (3) for conducting light irradiated from a Light Source (2) as well as a ring-shaped Light Emitter (4) attached to the leading end of the guide for emanating the light, an illumination device characterized by the Light Emitter (4) providing, within a Ring Channel (8) formed in Casing (7), a Light Emitting Body (6) formed in a ring shape with opposing Incident End Surfaces (6a, 6b) formed at both its ends at a prescribed interval and having the purpose of emanating from its peripheral surface to the exterior the light made incident on Incident End Surfaces (6a,

6b), and providing Reflection Elements (10a, 10b) between the Incident End Surfaces (6a, 6b) of Light Emitting Body (6) and having the purpose of reflecting onto Incident End Surfaces (6a, 6b) the light conducted into Casing (7), and by Light Emitting Body (6) being formed with its peripheral surface at the Bottom Section (8a) side of Ring Channel (8) formed into Reflection Surface (6ref) for causing diffusion reflection of the light advancing through Light Emitting Body (6) and directing it toward the Opening Section (8b) side of Ring Channel (8), and its peripheral surface at the Opening Section (8b) side of Ring Channel (8) formed into Radiating Surface (6out) for emitting to the exterior the light reflected by Reflection Surface (6ref).

### **Detailed Description of the Invention**

#### **[0001]**

#### **Technical Field to Which the Invention Belongs**

The present invention is related to illumination devices equipped with a ring-shaped light emitter for emanating the light conducted from a light source.

#### **[0002]**

#### **Prior Art**

With a CCD camera for performing product inspections, for example, an illumination device is installed around the lens in order to irradiate illumination light onto the products, thereby arranging to irradiate uniform light onto the products from a ring-shaped light passage slit. Fig. 5 is a perspective drawing that shows a former such illumination device, wherein Illumination Device 40 has Incident End 42 formed at one end of Fiber Bundle 41 (which bundles multiple optic fibers) to capture the light irradiated from the light source (not shown in drawing) and has Light Emitter 43 formed at the other end of Fiber Bundle 41. This Light Emitter 43 is formed by routing the light radiating ends of the optic fibers into a ring shape within ring-shaped Casing 45 (which is formed with ring-shaped Light Passage Slit 44) so as to face Passage Slit 44. In this way, the light irradiated from the light source will pass through Fiber Bundle 41 and be emitted in a ring shape from Light Emitter 43; by positioning the lens of CCD Camera 46, for example, in the center space of Casing 45, uniform light will be irradiated from the periphery of the

lens of CCD Camera 46 onto the product that is the photographic subject.

**[0003]**

### **Problem the Invention Seeks to Solve**

However, this type of Illumination Device 40 not only has many manufacturing processes related to formation by bundling the multiple optic fibers, it also expends manufacturing time with comparatively difficult and time-consuming processes such as arranging the light radiating end of the optic fibers into a ring shape; furthermore, it requires that multiple optic fibers be used to assemble Fiber Bundle 41 so that the light radiating end of the optic fibers can be carefully routed within Light Passage Slit 44, creating a problem with part expenses and subsequent manufacturing costs. Moreover, Fiber Bundle 41 is routed along the interior of Casing 45, with the increase in size creating a problem.

**[0004]**

The present invention undertakes the technical challenge of simplifying the structure and eliminating the need for complex operations at the time of manufacture, reducing manufacturing cost by decreasing the quantity of used optic fibers and obtaining a ring-shaped uniform diffused illumination.

**[0005]**

### **Means of Solving the Problems**

To solve the problems, the present invention is an illumination device that provides a ring-shaped light emitter for emanating the light conducted from a light source, and is characterized by the light emitter providing, within a ring channel formed in a casing, a light emitting body formed in a ring shape with opposing incident end surfaces formed at both its ends at a prescribed interval and having the purpose of emanating from its peripheral surface to the exterior the light made incident on its incident end surfaces, and providing reflection elements between the incident end surfaces of the light emitting body and having the purpose of reflecting onto the incident end surfaces the light conducted into the casing, and by the light emitting body being formed with its peripheral surface at the bottom section side of the ring channel formed into a reflection surface for causing diffusion reflection of the light advancing through the light emitting body and directing it

toward the opening section side of the ring channel, and its peripheral surface at the opening section side of the ring channel formed into a radiating surface for emitting to the exterior the light reflected by the reflection surface.

**[0006]**

According to the present invention, the light conducted to within the casing is reflected by the reflection elements and made incident on the incident end surfaces of the ring-shaped light emitting body and thereby made incident to the interior. The light emitting body has a reflective surface formed on its peripheral surface of the bottom side of the ring-shaped channel, and has a light radiating surface formed on its peripheral surface at the opening side of the ring-shaped channel, and therefore the light advancing through the interior of the light emitting body undergoes diffusion reflection at the reflection surface and is directed toward the opening section side of the ring-shaped channel and radiated to the exterior from the radiating surface. Because the light is made incident from both incident end surfaces at this time, a drop in light intensity made incident from one of the incident end surfaces will be compensated by light made incident from the other of the incident end surfaces, thereby irradiating light uniformly from the radiating surface. In addition, it is not necessary to route through the casing interior an optic fiber cable that has bundled multiple optic fibers, nor to arrange the light radiating end of each optic fiber into a ring shape, because it is sufficient to dispose the ring-shaped light emitting body, thereby enabling size reduction and simplification of the illumination device.

**[0007]**

**Mode for Implementing the Invention**

The following describes in detail a mode for implementing the present invention based on the drawings. Fig. 1 is a perspective drawing that shows an example of the illumination device according to the present invention; Fig. 2 is a bottom view drawing of the same; Fig. 3 is a side view of the same; Fig. 4 is a drawing with an expanded view of the light emitting body.

**[0008]**

Illumination Device 1 of this example comprises Light Guide 3 for conducting light

irradiated from a Light Source 2 as well as a ring-shaped Light Emitter 4 attached to the leading end of the guide for emanating the light. Light Guide 3 is formed by covering Fiber Bundle 5, which has bundle multiple optic fibers, and the Incident End 3<sub>in</sub> formed at one side is connected to Light Source 2 while the Radiation End 3<sub>out</sub> formed at the other side is connected to Light Emitter 4.

**[0009]**

Light Emitter 4 has, within a Ring Channel 8 formed in Casing 7, a Light Emitting Body 6 formed in a ring shape with opposing Incident End Surfaces 6a, 6b formed at both its ends at a prescribed interval and having the purpose of emanating from its peripheral surface to the exterior the light made incident on Incident End Surfaces 6a, 6b. Furthermore, Connector 9 is formed on Casing 7 to connect to Radiation End 3<sub>out</sub> of Light Guide 3, and Mirrors (reflection elements) 10a, 10b are placed between Incident End Surfaces 6a, 6b of Light Emitting Body 6 and in line with optical axis X of the light radiated from Light Guide 3 in order to divide and reflect to Incident End Surfaces 6a, 6b of Light Emitting Body 6 the light conducted to within Casing 7 by Light Guide 3.

**[0010]**

Light Emitting Body 6 is formed of a transparent acrylic material, for example; and, as shown in Fig. 4, a reflective coating is applied to its peripheral surface at the Bottom Section 8a side of Ring Channel 8, thereby forming Reflection Surface 6<sub>ref</sub> for causing diffusion reflection of the light advancing through Light Emitting Body 6 and directing it toward the Opening Section 8b side of Ring Channel 8; and its peripheral surface at the Opening Section 8b side of Ring Channel 8 is exposed, thereby forming Radiating Surface 6<sub>out</sub> for radiating to the exterior the light reflected by Reflection Surface 6<sub>ref</sub>. This arranges for the light that has been radiated from Radiating Surface 6<sub>out</sub> to be irradiated from Opening Section 8b side of Ring Channel 8 to the exterior as light in a ring shape.

**[0011]**

The above describes an example of the structure of the present invention, and the operation is described next. First, Light Emitter 4 of Illumination Device 1 is completed by attaching Mirrors 10a, 10b in the position opposing Connector 9 formed on Casing 7,

attaching Light Emitter Body 6 so that Mirrors 10a, 10b will be positioned between Incident End Surfaces 6a, 6b, and then closing Casing 7. Illumination Device 1 is completed by connecting linear-shaped Light Guide 3 to Connector 9 of Light Emitter 4. In this way, the product is completed merely by attaching each of the parts to the prescribed positions, without any laborious operations such as routing the optic fiber light radiating end in a ring shape, whereby the manufacturing method is greatly simplified and the manufacturing cost is reduced.

**[0012]**

When the Illumination Device 1 manufactured in this way is used for illumination with a manufacturing inspection CCD camera, for example, Incident End 3in of Light Guide 3 is connected to Light Source 2, and Casing 7 of Light Emitter 4 is mounted around the lens of CCD camera 11. As the light from Light Source 2 is irradiated, the light will be conducted internally by Incident End 3in of Light Guide 3 and will be irradiated to within Casing 7 from Radiation End 3out. The light irradiated to within Casing 7 will be divided by Mirrors 10a, 10b placed in line with optical axis X and reflected toward Incident End Surfaces 6a, 6b of Light Emitting Body 6.

**[0013]**

In continuation, the light reflected by Mirrors 10a, 10b will be made incident on Incident End Surfaces 6a, 6b of Light Emitting Body 6, and as the light advances within Light Emitting Body 6 from each direction, Reflection Surface 6ref will cause it to undergo diffusion reflection toward Radiating Surface 6out, and it will be irradiated to the exterior from Opening Section 8b of Ring Channel 8 formed in Casing 7. At this time, the intensity of the light advancing through Light Emitting Body 6 after being incident from one side Incident End Surface 6a will decrease as it approaches the other side Incident End Surface 6b, but the intensity of the light advancing through Light Emitting Body 6 after being incident from the other side Incident End Surface 6b will be greater in line with its proximity to Incident End Surface 6b. Accordingly, the decline in light intensity for light made incident from one side of either Incident End Surface 6a (6b) will be compensated by the light made incident from the other Incident End Surface 6b (6a), whereby light of overall uniform intensity will be irradiated from Opening Section 8b of Ring Channel 8.

**[0014]**

Furthermore, the above description presented the case in which the light was conducted from Light Source 2 through linear-shaped Light Guide 3 to Light Emitter 4, but the case of conducting the light directly from Light Source 2 to Light Emitter 4 is also acceptable. Additionally, linear-shaped Light Guide 3 is not limited to a part that removably mounts by Connector 9, as one that is fixed to Light Emitter 4 is also acceptable.

**[0015]**

### **Effect of the Invention**

As described above, according to the present invention, there is a comparatively simple structure and the elimination of the need for complex operations at the time of manufacture, and no utilization of expensive parts, whereby there is the effect of reducing manufacturing cost, and the superlative effect of providing uniform diffusion illumination by making light incident from both of a pair of incident end surfaces such that the reciprocally incident light compensates for the drop in intensity as the light advances through the light emitting body.

### **Brief Description of the Drawings**

Fig. 1 is a perspective drawing that shows an example of the illumination device according to the present invention.

Fig. 2 is a bottom view drawing of the same.

Fig. 3 is a side view of the same.

Fig. 4 is a drawing with an expanded view of the light emitting body.

Fig. 5 is a perspective drawing of the prior art illumination device.

### **Description of the Symbols**

1	Illumination Device
2	Light Source
3	Linear-Shaped Light Guide
3in	Incident End
3out	Radiation End

4	Light Emitter
5	Fiber Bundle
6	Light Emitting Body
6a, 6b	Incident End Surface
6ref	Reflection Surface
6out	Radiating Surface
7	Casing
8	Ring Channel
9	Connector
10a, 10b	Mirror (reflection element)

**[Translator Notes]**

1. Capitalization of part names is used only in paragraphs where the part names are followed by a drawing call-out number.
2. The translation uses four terms “emit,” “radiate,” “irradiate,” and “emanate” intentionally because the original uses four terms (even though they are synonymous); the use of four terms is not an inconsistency in the translation.
3. The author uses long sentences with internal references to describe components, which can make it difficult to follow subject, verb, object of the sentence. The translation attempts to produce sentences that allow following of the subject-verb logic while preserving descriptive details, sometimes with comma-demarcated phrases. (Example: “...characterized by the light emitter providing, within a ring channel formed in a casing, a light emitting body formed in a ring shape...”)
4. The drawings of Light Emitter 4 (Fig. 1, 3, 4) can be initially confusing, but the part consists of a single piece, cylindrical in cross section and round in shape, with the top half of cylindrical cross section processed for reflective surface (6ref) and the bottom half of cylindrical cross section not processed (6out).
5. It is helpful to remember that “Bottom Section (8a) side” in Fig. 3 is at the upper end of the device (but is the “bottom” of the down-facing channel).

Fig. 1

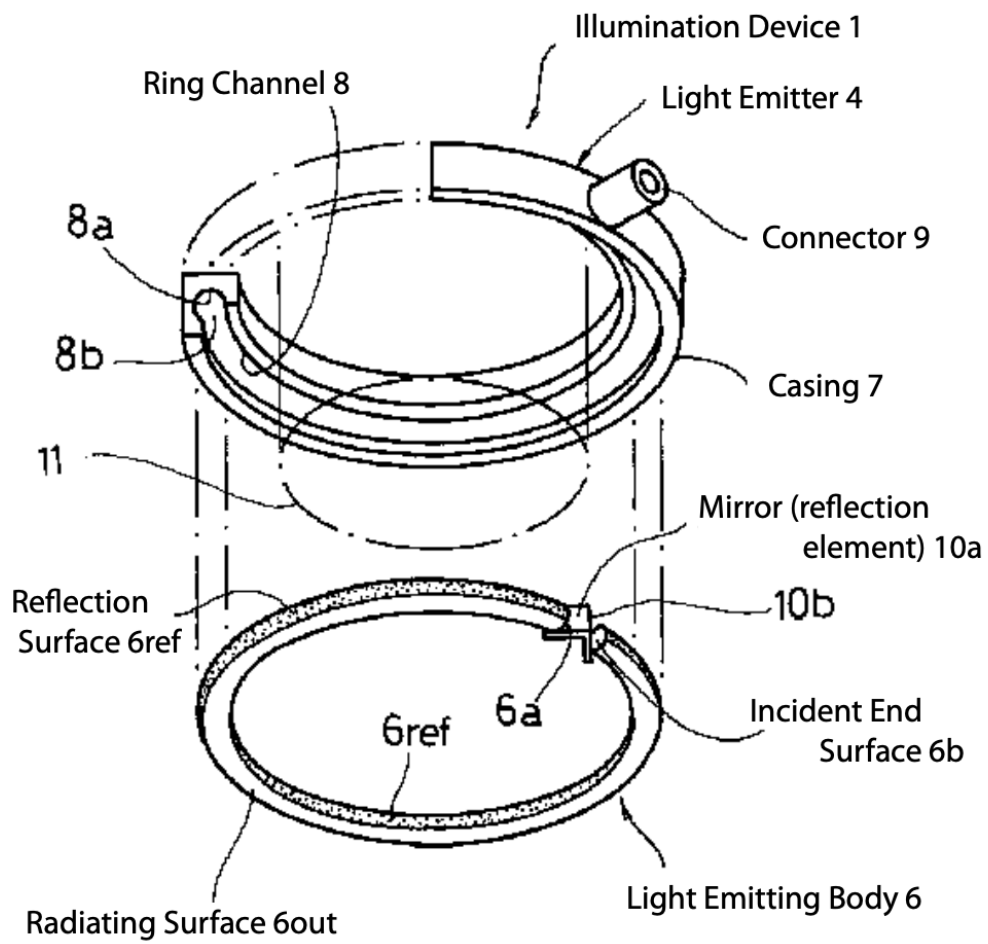

Fig. 2

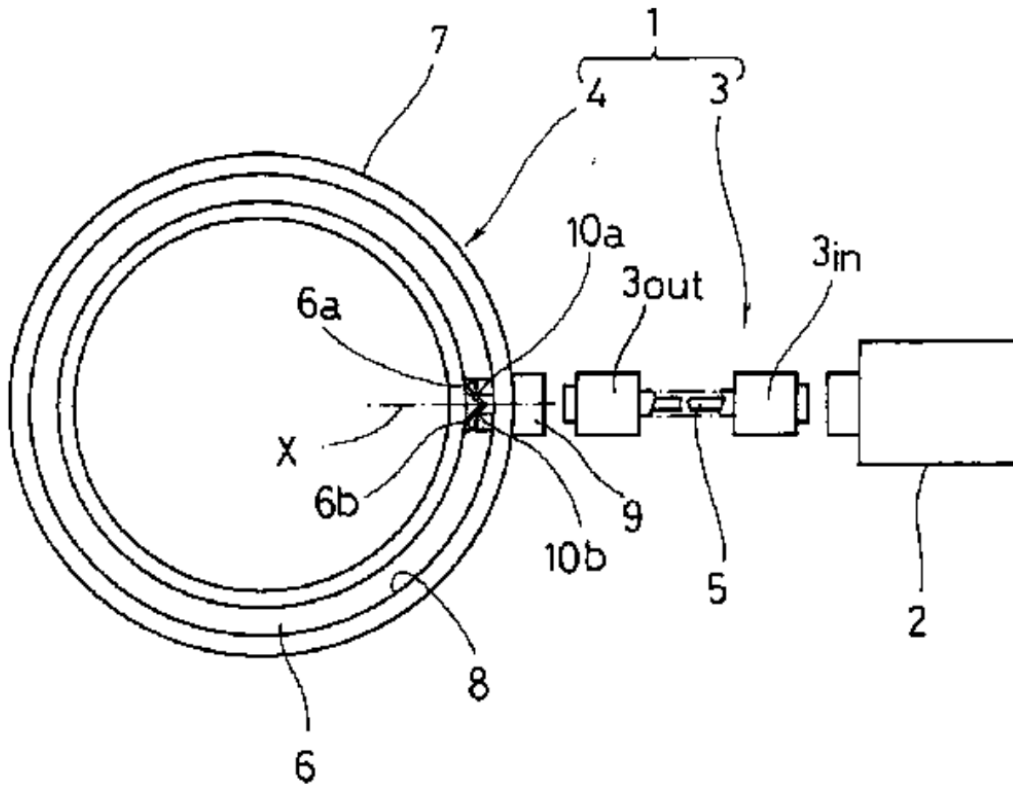

Fig. 3

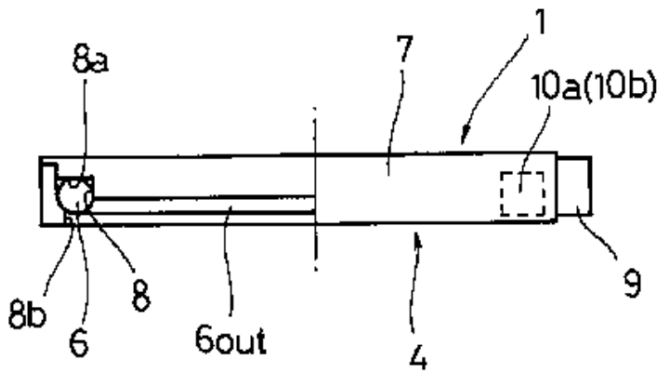

Fig. 4

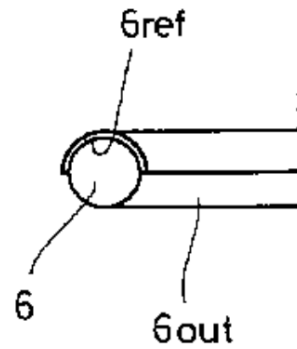

Fig. 5

