



US006799861B2

(12) **United States Patent**
Naghi et al.

(10) **Patent No.: US 6,799,861 B2**
(45) **Date of Patent: Oct. 5, 2004**

(54) **PORTABLE LIGHTING APPARATUS AND METHOD OF USE**

(75) Inventors: **David Naghi**, Los Angeles, CA (US);
Eric A. Hanscom, Los Angeles, CA (US)

(73) Assignee: **Technology Creations, Inc.**, Los Angeles, CA (US)

(*) Notice: Subject to any disclaimer, the term of this patent is extended or adjusted under 35 U.S.C. 154(b) by 55 days.

(21) Appl. No.: **09/810,795**

(22) Filed: **Mar. 15, 2001**

(65) **Prior Publication Data**

US 2002/0131263 A1 Sep. 19, 2002

(51) **Int. Cl.**⁷ **F21V 33/00**

(52) **U.S. Cl.** **362/198**; 362/253; 361/683; 361/686

(58) **Field of Search** 362/85, 109, 198, 362/199, 190, 191, 253, 396, 197, 419; 345/82; 361/683, 686; 348/373; G06G 3/32; F21V 33/00

(56) **References Cited**

U.S. PATENT DOCUMENTS

1,651,307 A	11/1927	Wilkinson	
3,065,339 A	11/1962	Fahey, Jr. et al.	240/25
D238,959 S	2/1976	Kurokawa et al.	D48/20 F
D251,687 S	4/1979	Kurokawa	D48/20 F
5,122,937 A	6/1992	Stoudemire	362/109
5,122,941 A	6/1992	Gross et al.	362/276
5,136,477 A	8/1992	Lemmey	362/198
5,183,325 A	2/1993	Hurdle	362/109
5,369,560 A *	11/1994	Friedman	362/396
5,379,201 A	1/1995	Friedman	362/191
D377,840 S	2/1997	Chang	D26/62
5,612,733 A *	3/1997	Flohr	348/14.16

5,615,945 A	4/1997	Tseng	362/226
5,702,175 A *	12/1997	Chen	362/191
D418,240 S	12/1999	Sherman	D26/63
6,141,052 A *	10/2000	Fukumitsu et al.	348/373
6,406,161 B1 *	6/2002	Lin et al.	362/287
6,587,151 B1 *	7/2003	Cipolla et al.	348/373
2001/0048409 A1	12/2001	Kim	345/82

FOREIGN PATENT DOCUMENTS

DE	9417969.7	2/1995
JP	410224687 A *	8/1998
JP	2000200115 A *	7/2000

OTHER PUBLICATIONS

Amazon.com product web page printout for "Adventure Book Light and Flashlight" by Lumatec; <http://www.amazon.com/exec/obidos/ASIN/b00000IJZM/104-9549104-0986847>; printed Mar. 2, 2000.

Book light product internet web page printout; http://store1.yimg.com/I/parksherman_1550_902141; printed Mar. 2, 2000.

"Designed Halogen Lamps With Multiple Features," *Taiwan Lighting*, Feb. 1997, p. 69.

FlyLight™ Notebook USB Light, Kensington Products; http://www.kensington.com/products/pro_d1334.html, Printed Feb. 15, 2001.

(List continued on next page.)

Primary Examiner—Thomas M. Sember

(74) *Attorney, Agent, or Firm*—Stephen C. Beuerle; Procopio Cory Hargreaves & Savitch LLP

(57) **ABSTRACT**

A light including a bendable body including opposite terminating portions, respective light sources carried at the terminating portions, at least one power source to power the light sources, wherein the bendable body is adapted to be wrapped at least partially around at least one of a user's neck and head to secure the light and adjusted so that the light sources are oriented in a desired configuration for optimal lighting of the one or more objects.

9 Claims, 4 Drawing Sheets

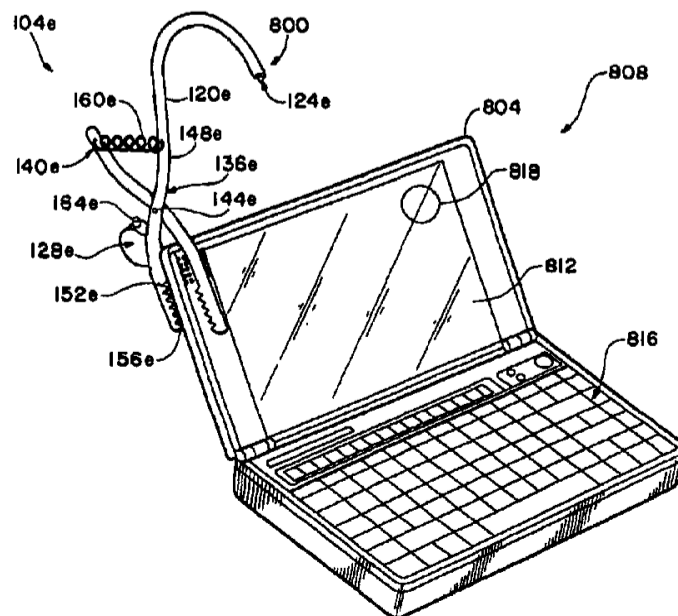

OTHER PUBLICATIONS

Igo.com product web page printout for “NBL-100 Notebook Light” by Interex; <http://www.igo.com/cgi-bin/ncommerce3/ProductDisplay?prmenbr=1&prfnbr=522530>; printed Jul. 21, 2000.

Sierra Gold Marketing “SGM28367” Clip On Light product web page printout; <http://www.sgm.simplenet.com/boutique/special/sgm28367.html>; printed Mar. 2, 2000.

“The Ittybitty Book Light” internet web page printout; <http://www.zelco.com/10013.jpg>; printed Mar. 2, 2000.

“Ultimate Palmtop Computer Lights™” internet web page printout; <http://www.std.com/sfl/3.pct.html>; printed Mar. 2, 2000.

* cited by examiner

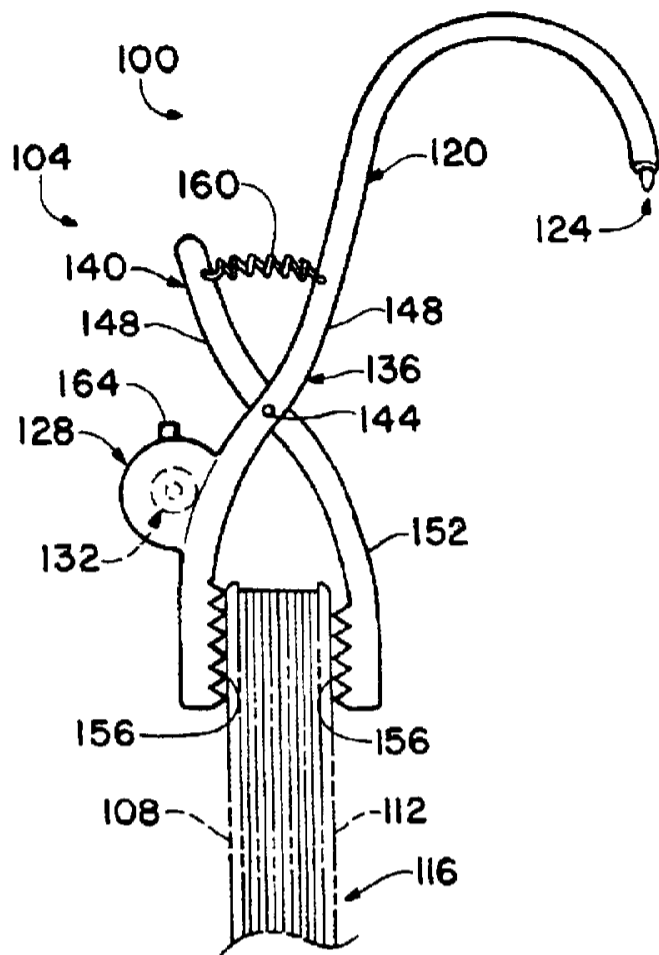

FIG. 1

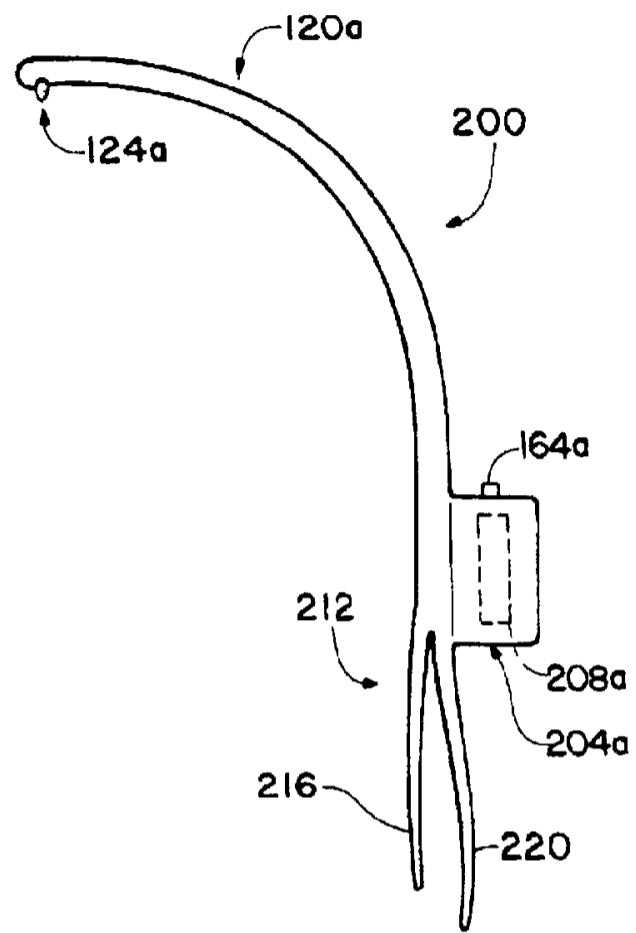

FIG. 2

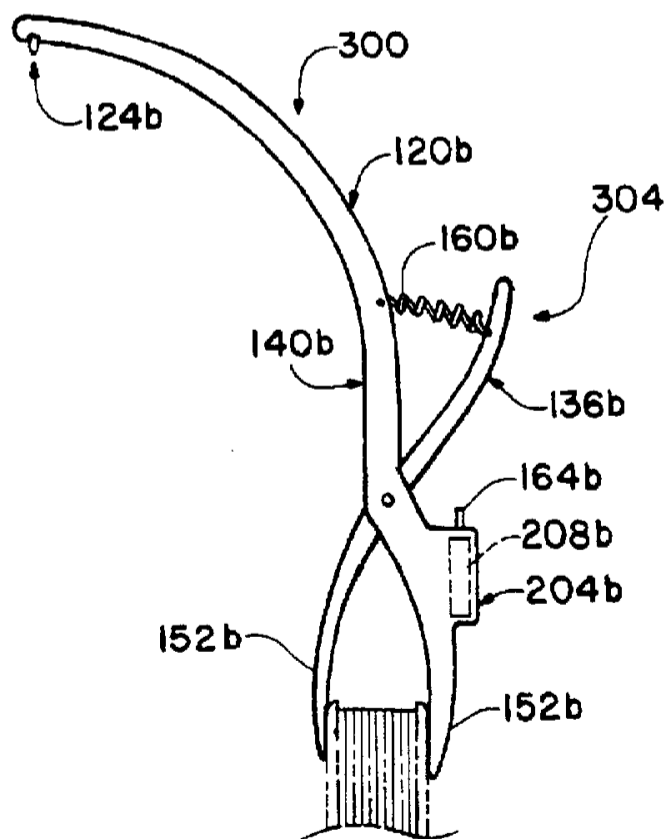

FIG. 4

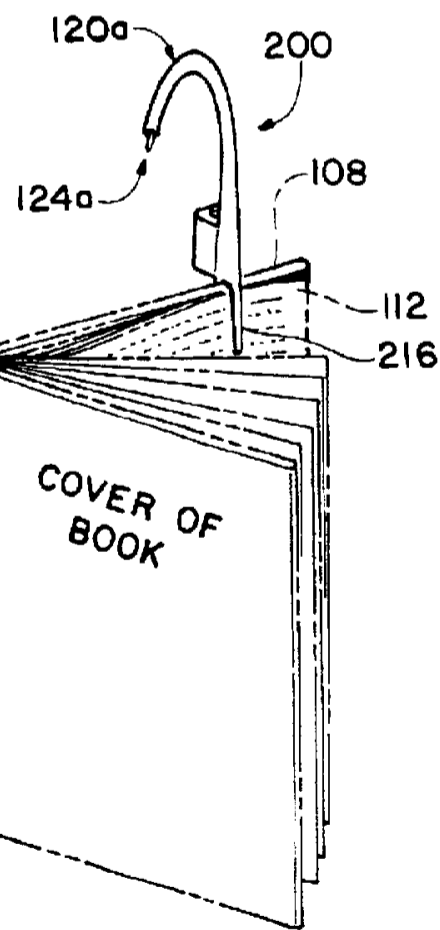

FIG. 3

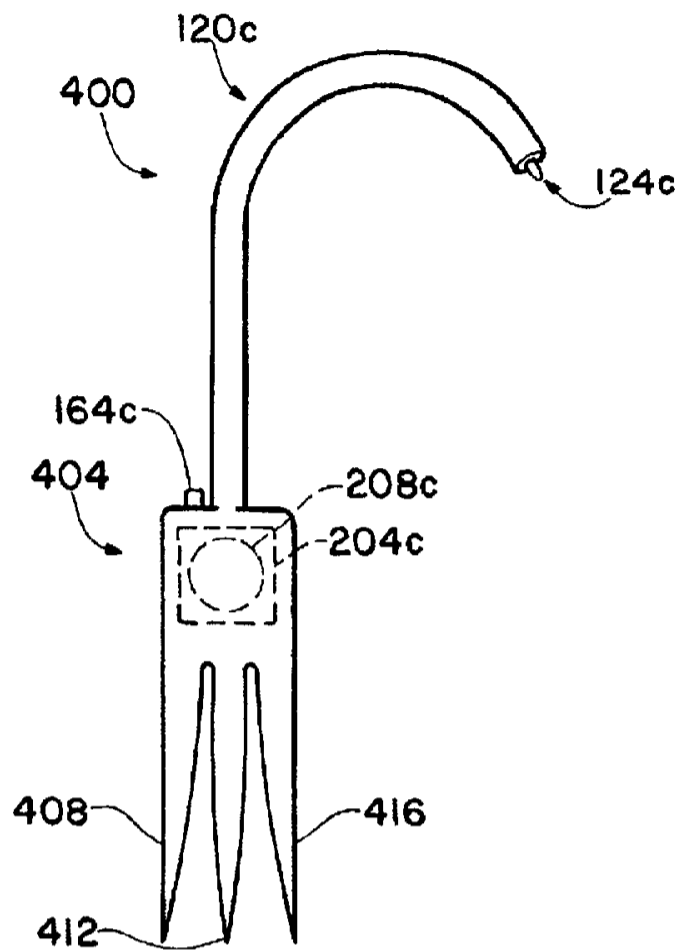

FIG. 5

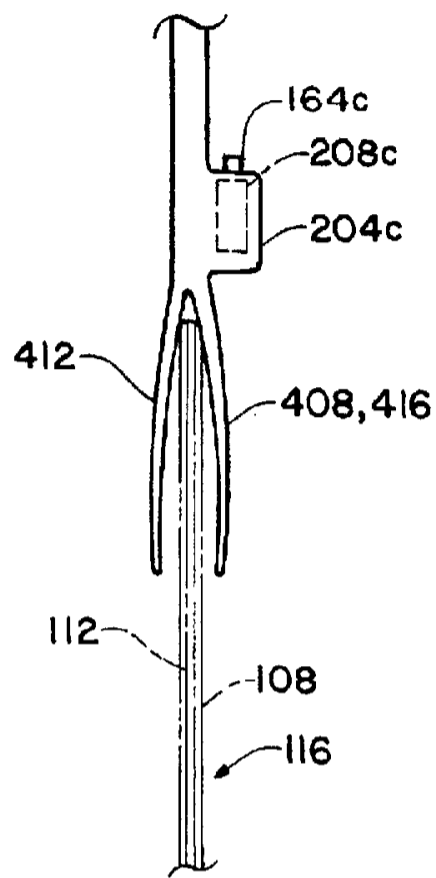

FIG. 6

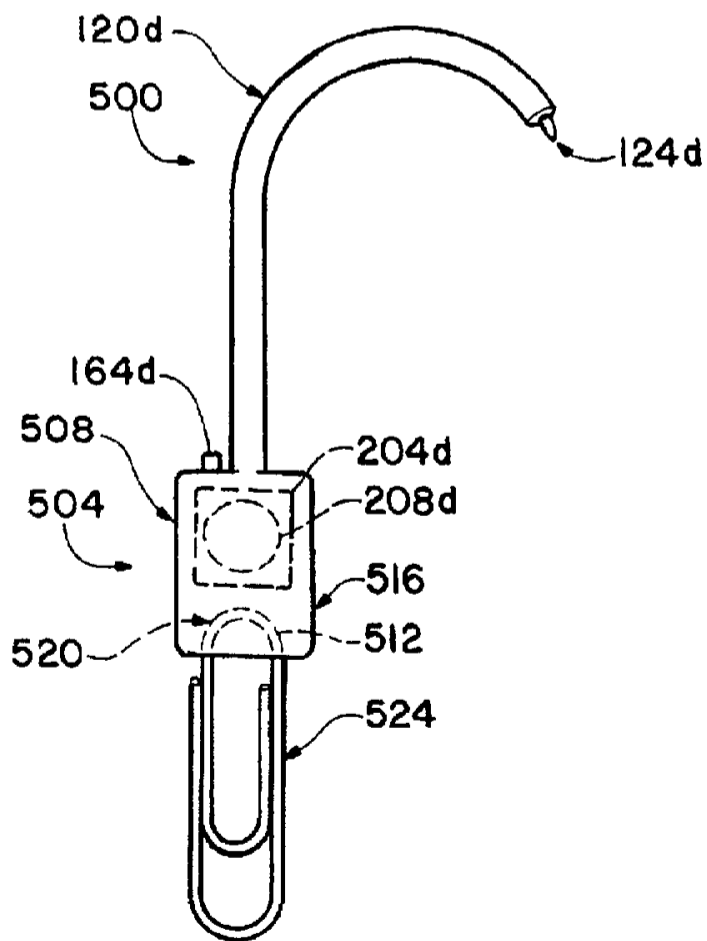

FIG. 7

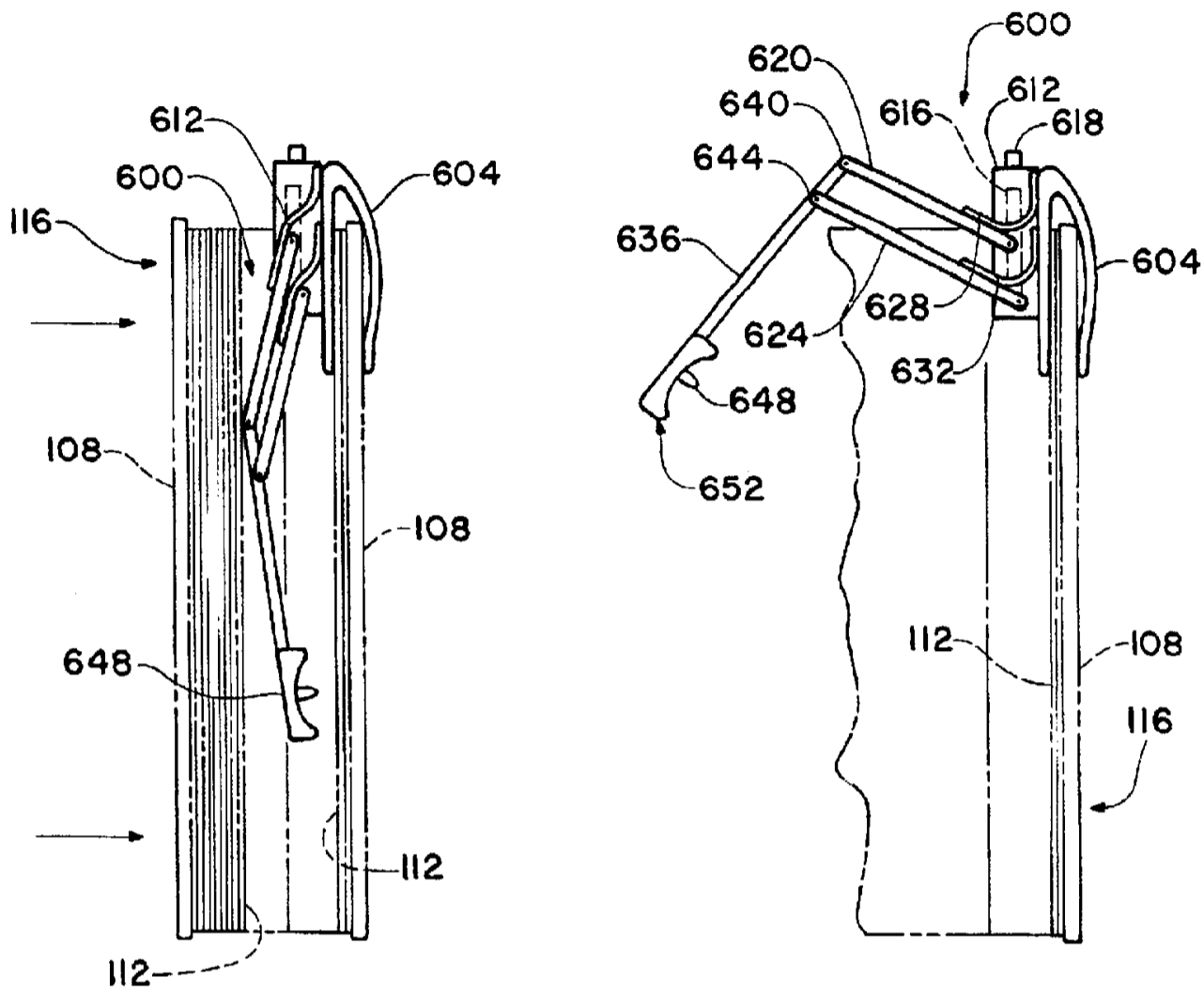

FIG. 8

FIG. 9

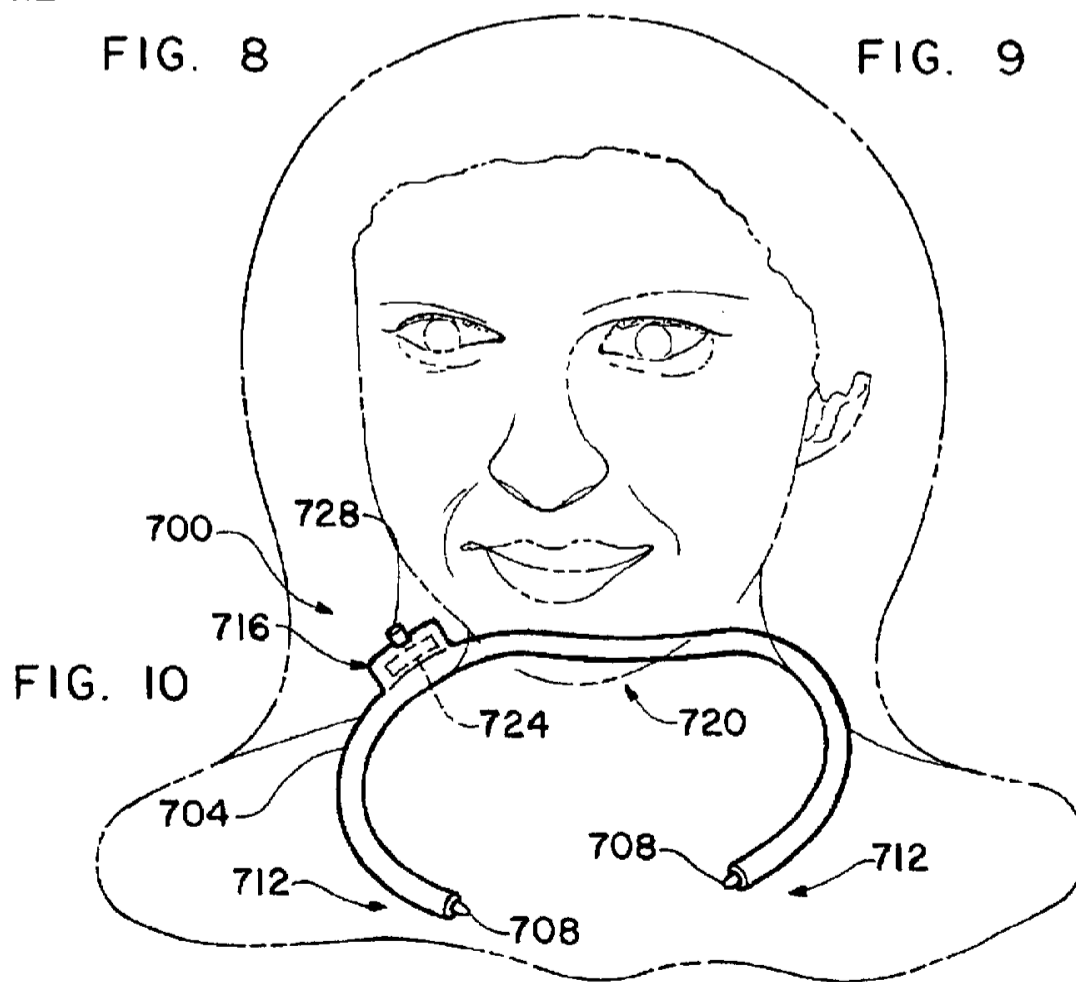

FIG. 10

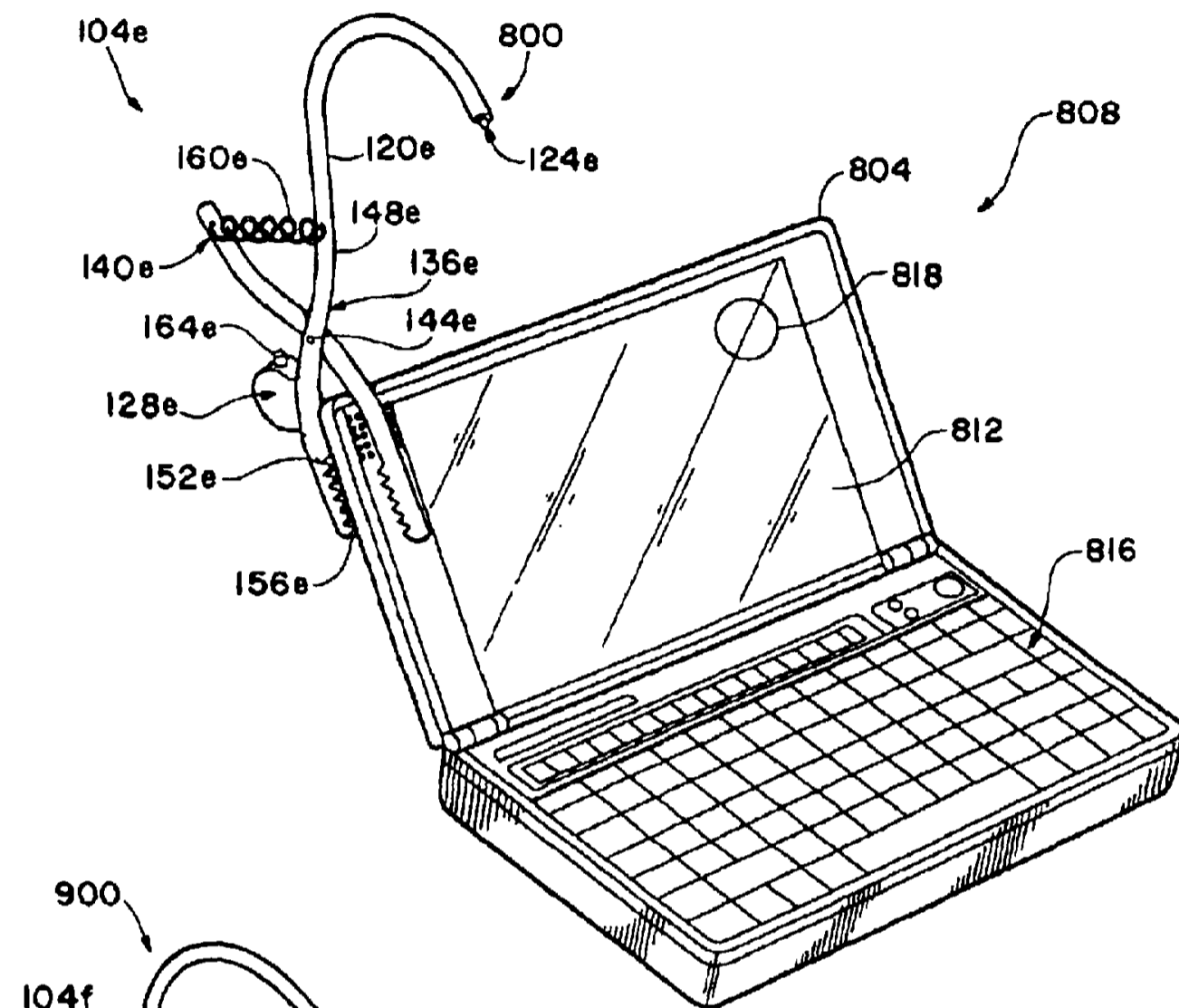

FIG. 11

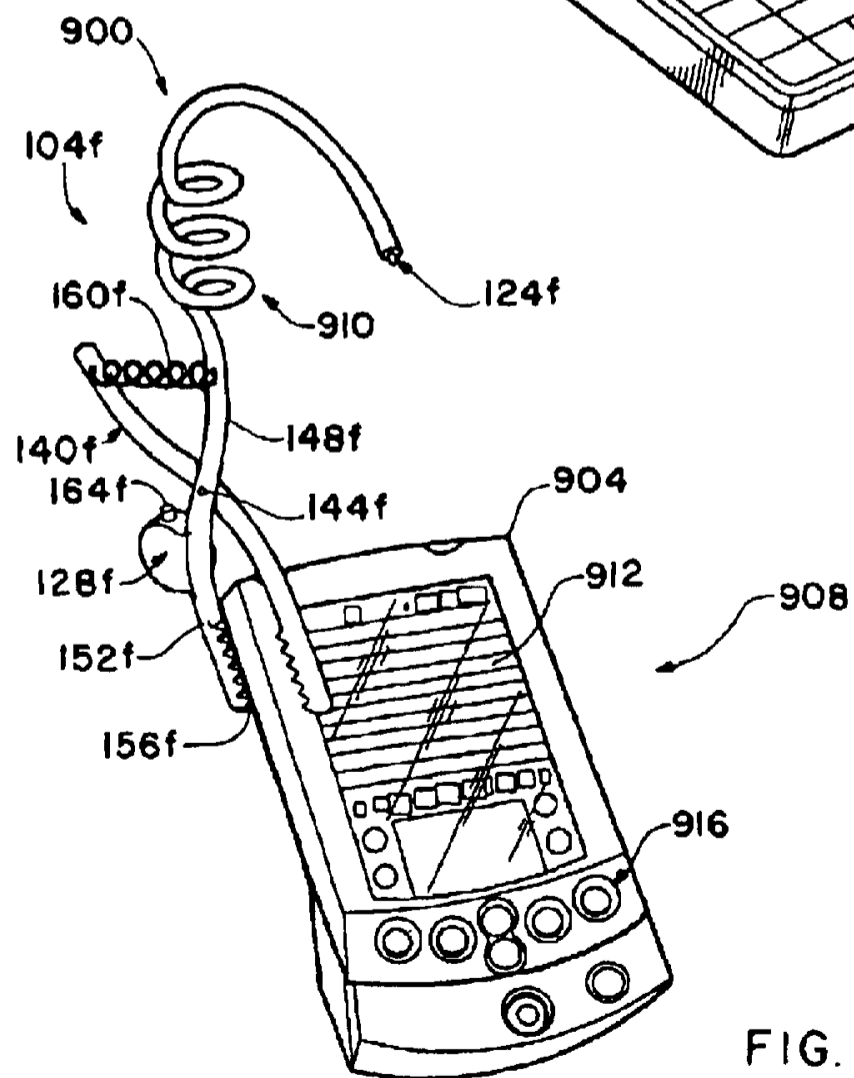

FIG. 12

1

PORTABLE LIGHTING APPARATUS AND METHOD OF USE

FIELD OF THE INVENTION

The present invention is in the field of portable lighting devices for illuminating objects.

BACKGROUND OF THE INVENTION

Reading lights such as book lights have been proposed in the past for illuminating the pages of a book in inadequate lighting conditions. A problem with these lights is that they tend to be relatively heavy and bulky, making their use impractical and clumsy, especially when used with pliable publications and/or small publications such as magazines and soft cover books. If used on a magazine, the bulkiness and weight of these reading lights bends the pages of the magazine, making their use impractical and clumsy. Another problem with these reading lights is that they use incandescent or fluorescent bulbs. Such light bulbs consume a relatively large amount of electricity, are inefficient, generate heat, and give only partial lighting across the entire visible spectrum. As a result, these reading lights require relatively large, more powerful batteries, consume batteries quickly, may bum the reader if the incandescent bulb comes in contact with the reader, require relatively large light housings to accommodate the heat of the incandescent bulb and large batteries, and provide unsatisfactory lighting of the reading materials. Also, the heaviness of prior book lights and the heat of the bulb create an inherently dangerous potential for fire if the light bends the flammable magazine or book page over and the hot bulb contacts the page.

Accordingly, there is a long felt need for a simple, light-weight, energy-efficient, economical device that can adequately illuminate pliable reading materials and/or small reading materials such as magazines and soft cover books without the drawbacks associated with prior reading lights.

There is also a long felt need for a simple, light-weight, energy-efficient, economical device and related method that can be used with other objects such as, but not by limitation, laptop computers, Personal Digital Assistants, digital cameras, and for general lighting of objects.

SUMMARY OF THE INVENTION

An aspect of the invention involves a method of illuminating one or more objects associated with a laptop computer comprising the steps of attaching a light to a support surface of the laptop computer and illuminating one or more objects associated with the laptop computer with at least one LED of the light.

An additional aspect of the invention involves a method of illuminating one or more objects associated with a PDA comprising the steps of attaching a light to a support surface of the PDA and illuminating one or more objects associated with the PDA with at least one LED of the light.

A further aspect of the invention involves a light for lighting one or more objects. The light includes a bendable body including opposite terminating portions, respective light sources carried at the terminating portions, at least one power source to power the light sources, wherein the bendable body is adapted to be wrapped at least partially around at least one of a user's neck and head to secure the light and adjusted so that the light sources are oriented in a desired configuration for optimal lighting of the one or more objects.

A still further aspect of the invention involves a method of illuminating one or more objects comprising the steps of

2

providing a light including a bendable body with opposite terminating portions, respective light sources carried at the terminating portions; wrapping the bendable body at least partially around a user's neck; adjusting the bendable body so that the light sources are oriented in a desired configuration; and illuminating one or more objects with the illumination sources.

A yet further aspect of the invention includes a method of illuminating an object of a camera. The method includes providing an attachable light including at least one LED powered by at least one power source; attaching the light to a support surface; and illuminating an object of a camera with the light.

Further objects and advantages will be apparent to those skilled in the art after a review of the drawings and the detailed description of the preferred embodiments set forth below.

BRIEF DESCRIPTION OF THE DRAWINGS

FIG. 1 is a side-elevational view of an embodiment of a reading light attached to a reading publication.

FIG. 2 is a side-elevational view of an additional embodiment of a reading light.

FIG. 3 is perspective view of the reading light illustrated in FIG. 2 attached to a back cover and multiple pages of a soft-cover book.

FIG. 4 is a side-elevational view of another embodiment of a reading light.

FIG. 5 is a side-elevational view of a further embodiment of a reading light.

FIG. 6 is an end view of the reading light illustrated in FIG. 5 attached to a page of a reading publication.

FIG. 7 is a side-elevational view of a further embodiment of a reading light.

FIG. 8 is a side-elevational view of a still further embodiment of a reading light, with the reading light shown in a closed, collapsed position.

FIG. 9 is a side-elevational view of the reading light of FIG. 8, with the reading light shown in an active, expanded position.

FIG. 10 is a front view of a further embodiment of a light that may be used as a reading light or general purpose light, and illustrates the light around a user's neck.

FIG. 11 is a perspective view of a light similar to the reading light illustrated in FIG. 1, but associated with a laptop computer.

FIG. 12 is a perspective view of another embodiment of a light similar to the reading light illustrated in FIG. 1, but associated with a PDA.

DETAILED DESCRIPTION OF PREFERRED EMBODIMENTS

With reference to FIG. 1, a reading light **100** constructed in accordance with an embodiment of the invention will now be described. The reading light **100** includes a mounting mechanism **104** for mounting the reading light to a reading support surface such as, but not limited to, a cover **108**, one or more pages **112**, and/or a spine of a reading publication **116** and an adjustable, bendable body portion **120** that terminates at one end in at least one light source **124** for illuminating the page(s) **112** of the publication **116**. The bendable body portion **120** may have a configuration other than that shown such as, but not by way of limitation, coiled, curvilinear, serpentine, wave-like, or rectilinear. If the bend-

able body portion **120** is coiled and becomes uncoiled, the bendable body portion **120** can be reshaped into a coil by bending and wrapping the body portion **120** around a pen, pencil, or similar instrument and removed. The mounting mechanism **104** carries a power housing **128** that houses at least one power source **132** for powering the light source **124**.

The mounting mechanism **104** includes first and second arms **136**, **140**, respectively, pivotally connected by a pin **144**. The arms **136**, **140** include upper arm portions **148** and lower arm portions **152**. The upper arm portion **148** of the first arm **136** merges into the adjustable, bendable body portion **120**. Both the first arm **136** and body portion **120** carry a bendable wire that electrically couples the power source **132** with the LED **124**. The lower arm portion **152** of the first arm carries the power housing **128**. The lower arm portions **152** terminate in opposing engagement teeth **156**. A spring **160** extends between the upper arm portions **148**.

The light source **124** is preferably a wide-angle, white LED **9** that may be housed in a light housing (not shown). Although the light source **124** is shown as a single LED, multiple LEDs may be used. An LED is advantageous because it draws little electrical power during operation, prolonging the power life of the power source **132**. The low-power draw of the LED is especially advantageous with respect to a reading light because a low power draw allows for a small power source, and, hence, a small reading light. A smaller reading light means the reading light can be attached to pliable pages and/or a cover without bending the pages/cover. A smaller reading light is also less clumsy than a larger reading light. An LED is small, lightweight and also does not burn out like conventional filament light bulbs, as used in prior art reading lights. As a result, the LED does not need to be replaced, reducing maintenance of the light **100**. Because an LED does not emit heat, it uses power more efficiently and can be formed into plastic without heat-warping effects on the light housing. An LED also does not have a filament like conventional bulbs used in prior art reading lights. Therefore, an LED casts light in a more even and focused manner than bulbs used in prior reading lights. The wide-angle LED broadly casts light across the entire page **112** or adjacent pages **112** of the reading publication **116**, while at the same time allowing the reading light **100** to rise a short distance above the page **112**, resulting in a low-profile reading light **100**. The low profile of the reading light **100** reduces the obstructive effect the light **100** may present to a user reading the publication **116** and reduces torque bending on pliable pages **112** or a cover **108**. A white light LED is further preferred because it emits the full spectrum of visible light, unlike conventional light bulbs used in prior art reading lights, resulting in more vibrant, vivid and true colors. The resulting light from a white light LED is also more comfortable to a reader's eyes than the light from conventional light bulbs.

Because the LED draws little power, the power source **132** is a small, low-voltage power source such as, but not limited to, an AA battery, an AAA battery, an AAA battery, or a watch battery. Disposable or non-disposable (e.g., rechargeable) batteries may be used. Other power sources such as, but not by way of limitation, one or more fuel cells may also be used. Although a single power source **132** is shown, multiple power sources **132**, e.g., batteries, may be used to power the LED. A switch **164** such as an on/off switch is preferably used to turn the reading light **100** on or off. A dimmer switch, e.g., a variable resistor, may be used for controlling the brightness of the light source **124**.

The reading light **100** will now be described in use. The reading light **100** is mounted or applied to the reading

publication **116** by clamping the engagement teeth **156** of the lower arm portions **152** onto a support surface of the reading publication **116**. Possible support surfaces may include one or more of the following: a hard cover, a soft cover, one or more pages or surfaces of the book, magazine, article, document, brochure, binder, folder, planner, personal organizer, map, any paper items used on a clipboard, a clipboard, and the like. The mounting mechanism **104** is applied to the support surface by squeezing the upper arm portions **148** with enough force to overcome a counteracting force by the spring **160**, locating the engagement teeth **156** of the lower arm portions **152** over the support surface, and releasing the pressure on the upper arm portions **148** so that the spring **160** causes the lower arm portions **152** and teeth **156** to grip the support surface. The light source **124** is activated by moving the switch **164** to an "on" position and deactivated by moving the switch **164** to an "off" position. The light source **124** is oriented to a desired position by bending the adjustable, bendable body **120** to a desired configuration. The low profile of the reading light **100** caused by using a wide-angle LED, and light weight of the tool light **100** caused by using a small power source and an LED reduces the torque forces on the pliable page(s) and/or soft cover of the book, magazine, etc., preventing bending of the pliable pages of the reading publication **116** when the reading light **100** is mounted to the publication **116**. The design also allows the reading light **100** to be mounted in the middle of the book, magazine, or spine for better support without obstructing text, pictures, or printed areas. The reading light **100** may also be mounted to the side of a reading support surface.

With reference to FIG. 2, a reading light **200** constructed in accordance with an additional embodiment of the invention will now be described. Elements similar to those described above with respect to FIG. 1 are identified with like reference numerals, but with an "a" suffix. The reading light **200** is similar to the reading light **100** described above with respect to FIG. 1, except a power housing **204** is sized to carry a small, flat watch battery **208** and a mounting mechanism **212** is different than the mounting mechanism **104** discussed with respect to FIG. 1. The mounting mechanism **212** is a sleeve defined by a first generally rectangular, flexible sleeve member **216** and a second generally rectangular, flexible sleeve member **220**.

With reference additionally to FIG. 3, use of the reading light **200** is similar to that described above for the reading light **100**, except instead of clipping the reading light **100** to the publication **116**, the sleeve **212** of the reading light **200** is slid over the cover **108** and/or the one or more pages **112** to attach the reading light **100** to the reading publication **116**. When the reading light **100** is mounted to the reading publication **116**, the reading support surface is disposed between the first generally rectangular, flexible sleeve member **216** and the second generally rectangular, flexible sleeve member **220**. The light source **124a**, e.g., LED, is activated by moving the switch **164a** to the "on" position and deactivated by moving the switch **164a** to the "off" position.

With reference to FIG. 4, a reading light **300** constructed in accordance with another embodiment of the invention will now be described. Elements similar to those described above with respect to FIGS. 1–3 are identified with like reference numerals, but with a "b" suffix. The reading light **300** is similar to the reading light **200** described above with respect to FIGS. 2 and 3, except a mounting mechanism **304** is different than the mounting mechanism **212**. The mounting mechanism **304** is a clip-like mechanism similar to the mounting mechanism **104** described above with respect to

5

FIG. 1, except the lower arm portions **152b** do not include opposing sets of engagement teeth **156**. The reading light **300** is applied to the cover **108** and/or one or more pages **112** of the publication **116** in the same manner as that described above for the reading light **100**.

With reference to FIGS. **5** and **6**, a reading light **400** constructed in accordance with a further embodiment of the invention will now be described. Elements similar to those described above with respect to FIGS. **1–4** are identified with like reference numerals, but with a “c” suffix. The reading light **400** is similar to the reading light **200** described above with respect to FIGS. **2** and **3**, except a mounting mechanism **404** is different than the mounting mechanism **212**. The mounting mechanism **404** includes three elongated, flexible, triangular fingers: a first finger **408**, a second finger **412**, and a third finger **416**. With reference to FIG. **6**, the reading light **400** is mounted to the reading publication **116** by sliding the mounting mechanism **404** over the cover **108** and/or the one or more pages **112** so that the first finger **408** and third finger **416** are disposed on one side and the second finger **412** is disposed on the other side.

With reference to FIG. **7**, a reading light **500** constructed in accordance with a still further embodiment of the invention will now be described. Elements similar to those described above with respect to FIGS. **1–5** are identified with like reference numerals, but with a “d” suffix. The reading light **500** is similar to the reading lights described above, but has a different mounting mechanism **504**. The mounting mechanism **504** includes a base **508** with a recess **512** in a bottom portion **516**. The recess is configured to slidably receive a top portion **520** of a paper clip **524**. The reading light **500** is mounted to the reading publication **116** by sliding the paper clip **524** over the cover **108** and/or the one or more pages **112**.

With reference to FIGS. **8** and **9**, a reading light **600** constructed in accordance with a still further embodiment of the invention will now be described. The reading light **600** includes a flexible U-shaped bracket **604** that is configured to mount to the cover **108** and/or one or more pages **112** of the publication **116**. A base **612** is attached to the bracket **604** and carries a power source **616** such as a watch battery. The base **612** may also carry an on/off switch **618** for activating or deactivating the reading light **600**. A pair of pivot arms **620**, **624** are pivotally connected to the base **612**. A pair of respective springs **628**, **632** extend between the base **612** and the pivot arms **620**, **624**. A support arm **636** is pivotally connected to distal ends **640**, **644** of the pivot arms **620**, **624**. The support arm **636** carries a light source **648**, e.g., LED. The light source **648** is located within a light housing **652**. The light source **648** is electrically coupled to the power source **616**.

In use, the reading light **600** is attached to the reading publication **116** by mounting the bracket **604** to the cover **108** and/or the one or more pages **112**. The springs **628**, **632** urge the pivoting arms **620**, **624** to the active, expanded position shown in FIG. **9**. In this position, the support arm **636** is automatically oriented in the position shown for illuminating the page(s) **112** with the light source **648**. The light source **648** may be activated by moving the switch **618** to the “on” position. In an alternative embodiment, instead of (or in addition to) the switch **618**, the position of at least one of the pivoting arms **620**, **624**, may control the on/off condition of the light source **648**. For example, the light source **648** may be automatically activated when the reading light **600** is in the position shown in FIG. **9** and deactivated when the reading light **600** is in the position shown in FIG. **10**. Closing the reading publication **116**, as illustrated in

6

FIG. **8**, forces the reading light **600** to the position shown. Thus, the reading light **600**, when not in use, may be stored in the reading publication **116** so that the reading light **600** is ready for use the next time the reading publication **116** is opened and serves as a page marker.

Although the reading light **600** has been described in conjunction with a reading publication, the reading light **600** is ideal for use with other objects that are opened or closed such as day planners, folders, binders, and the like. For example, the bracket **604** of the reading light **600** may be attached to the cover of a day planner and stored in the day planner in the position shown in FIG. **8**. When a user opens the day planner, the reading light automatically orients itself to the position shown in FIG. **9** for illuminating the day planner.

With reference to FIG. **10**, a reading light **700** constructed in accordance with a still further embodiment of the invention will be described. The reading light **700** includes a bendable wire body **704** having light sources **708** located at opposite terminal portions **712** of the bendable body **704**. The light sources **708** are preferably white LEDs, but may be other light sources. A power source compartment **716** may be located at or near a central portion **720** of the body **707**. The power source compartment **716** houses one or more power sources **724** for powering the light sources **708**. The one or more power sources **724** may include one or more batteries, e.g., watch battery, AA battery, AAA battery, AAAA battery, rechargeable battery, one or more fuel cells, or the like. The power source compartment **716** may also include a standard on/off switch **728** for turning the light sources **708** on or off. A switch may be used to either power both light sources on at once or off at once. Alternatively, a single switch or a pair of switches may be used to control power to both light sources **708** at once and individual light sources **708**. The power source compartment **716** also houses suitable electronics for electrically communicating the one or more power sources **724** with the light sources **708** and controlling the light sources **708**. The electronics may include a dimmer mechanism, e.g., variable resistor, for controlling the brightness of the light sources **708**.

The bendable body **704** is preferably worn around the user’s neck. Padding such as a compressed foam material may surround substantially all or at least a portion of the bendable body **704** for increased comfort. The central portion **720** of the reading light **700** may be made of a curved, resilient, flexible plastic material (e.g., such as that used with headphones) so that the reading light may be worn and retained on the neck or head of the user without slipping.

The reading light **700** will now be described in use. The light sources **708** of the reading light **700** are turned on using the on/off switch **728** and the bendable body **704** is wrapped around the rear half of the user’s neck. The bendable body **704** allows the reading light **700** to be bent to a secure shape (e.g., horse shoe configuration) snugly yet comfortably around the user’s neck for securing the bendable body **704** to the user’s neck. Padding around the bendable body **704** makes the reading light more comfortable for the user to wear around his or her neck. As indicated above, the reading light **700** may also be worn on the user’s head, similar to wearing a pair of headphones. In an embodiment of the reading light **700** where the reading light **700** includes the resilient, flexible material in the central portion **720**, the resilient, flexible material helps to retain the reading light **700** to the user’s head or neck. The opposite terminal portions **712** may be bent to a desired configuration for optimal illumination of the reading publication. The brightness of the light sources **708** may be adjusted with the dimmer mechanism.

Although the light **700** has been described as a reading light for illuminating a reading publication, the light **700** may be used to illuminate an object or objects other than reading publications. Further, the light **700** does not have to be worn around users neck or head. For example, the light **700** may be wrapped around a user's arm or other object to secure the light **700**. The light **700** may also be bent to a configuration, e.g., helical configuration, where the light **700** may rest on a support surface such as table for illumination purposes. Thus, the bendable body **704** may be bent to an infinite number of positions and configurations for optimal lighting.

Although the light **100, 200, 300, 400, 500, 600, 700** has been described to illuminate a reading publication, the light may be used to illuminate a variety of other objects because the light can be conveniently secured to a variety of different support surfaces.

For example, with reference to FIG. **11**, a laptop or notebook light **800** similar in construction to the reading light **100** described with respect to FIG. **1** is shown clipped to a display frame **804** of a laptop computer **808**. Elements similar to those described above with respect to FIG. **1** are identified with like reference numerals, but with an "e" suffix. The laptop light **800** may be used to illuminate objects associated with the laptop **808** such as, but not by way of limitation, a screen **812**, a keyboard **816**, an object of a digital camera **818**, or any other object(s) in the area of the laptop **808**, e.g., papers, documents, etc. A method of illuminating an object of the digital camera **818** may include attaching the light **800** to a support surface such as the display frame **804**, and illuminating the object of the camera **818** with an LED of the light **800**. Although the light **800** has been described as being used with a digital camera, the light **800** may be used with video cameras, flash cameras, or other types of cameras. Further, the light **800** may be integrated with the camera and may draw power from the same power source as that powering the camera.

With reference to FIG. **12**, a Personal Digital Assistant ("PDA") light **900** similar in construction to the reading light **100** described with respect to FIG. **1** is shown clipped to a frame **904** of a PDA **908** such as a PALM PILOT®. Elements similar to those described above with respect to FIG. **1** are identified with like reference numerals, but with an "F" suffix. The PDA light **900** is similar to the reading light **100**, except the PDA light **900** is shown with an helical, bendable wire body **910**. Like the laptop light **800**, the PDA light **900** may be used to illuminate a screen **912**, a keypad **916**, or anything in the area of the PDA **908**.

Examples of other objects that the light **100, 200, 300, 400, 500, 600, 700, 800, 900** may be used with include, but not by way of limitation, remote controls, internet phones, cell phones, non-backlit or insufficiently lit handheld video game devices, calculators, portable electronics with a display

or keyboard, glucose meters, medical equipment, dental equipment, hand tools, power tools, and other hand-held devices.

It will be readily apparent to those skilled in the art that still further changes and modifications in the actual concepts described herein can readily be made without departing from the spirit and scope of the invention as defined by the following claims.

What is claimed is:

1. A method of illuminating one or more objects of a combination digital camera and light associated with a laptop computer, comprising the steps of:

providing a combination digital camera and light with the laptop computer, the combination digital camera and light integrated with one another and drawing power from the same power source, the light of the combination digital camera and light including at least one LED;

drawing power from the same power source with the integrated, combination digital camera and light;

illuminating one or more objects of the digital camera of the integrated, combination digital camera and light associated with the laptop computer with at least one LED of the light of the combination digital camera and light.

2. The method of claim **1**, further including the step of attaching the light of the combination digital camera and light to a display frame of the laptop computer.

3. The method of claim **1**, wherein the combination digital camera and light include a bendable body that carries the at least one LED, and the method further includes bending the body to orient the at least one LED and digital camera to a desired lighting position.

4. The method of claim **1**, wherein the at least one LED and digital camera of the combination digital camera and light are powered by at least one rechargeable power source.

5. The method of claim **1**, wherein the at least one LED and digital camera of the combination digital camera and light are powered by at least one watch battery.

6. The method of claim **1**, further including switching the at least one LED of the combination digital camera and light on and off with a switch.

7. The method of claim **1**, wherein the at least one LED of the combination digital camera and light is at least one white LED.

8. The method of claim **1**, wherein the at least one LED of the combination digital camera and light is at least one wide-angle LED.

9. The method of claim **1**, wherein the combination digital camera and light is integrated with the laptop computer.

* * * * *