



(19) **United States**

(12) **Patent Application Publication**  
**Lin**

(10) **Pub. No.: US 2002/0190615 A1**

(43) **Pub. Date: Dec. 19, 2002**

(54) **STRUCTURE OF A GARBAGE-BOX**

(57) **ABSTRACT**

(76) Inventor: **Chung Jen Lin, Taipei City (TW)**

A structure of a garbage-box having a container body and a collection container, a moving door module being provided to the garbage inlet of the container body, characterized in that a sensor is provided to a top plate of the container body to sense the approaching of a person to open the moving door on the container body, another sensor is located within the container body, a pair of corresponding inverted L-shaped guiding rail seat are provided at the inner wall of the container body, the transmission shaft is pivotally mounted to the two guiding rail seats, the two ends of the transmission shaft are respectively mounted with a zigzag gear to drive flexible moving door, the bottom end of the flexible moving door, corresponding to the micro-touch switch, is provided with a pushing block so as to sense the opening of the flexible moving door.

Correspondence Address:

**Chung Jen Lin**  
**PO Box 82-144**  
**TAIPEI (TW)**

(21) Appl. No.: **09/880,808**

(22) Filed: **Jun. 15, 2001**

**Publication Classification**

(51) **Int. Cl.<sup>7</sup> ..... A47B 88/00**

(52) **U.S. Cl. .... 312/297; 312/319.5**

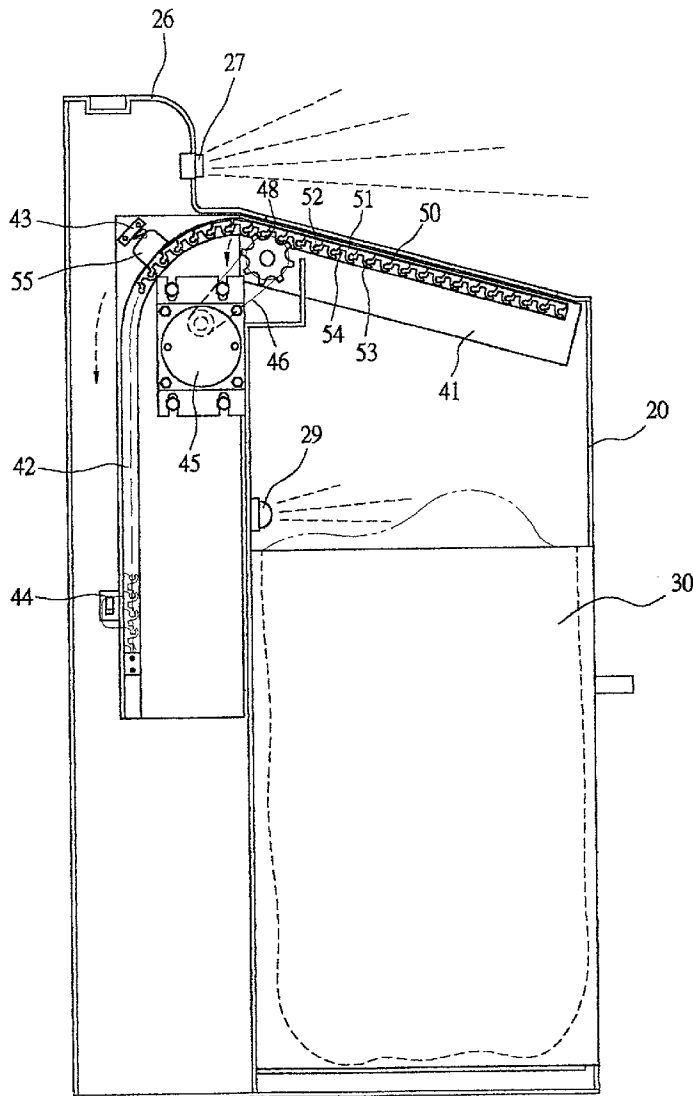

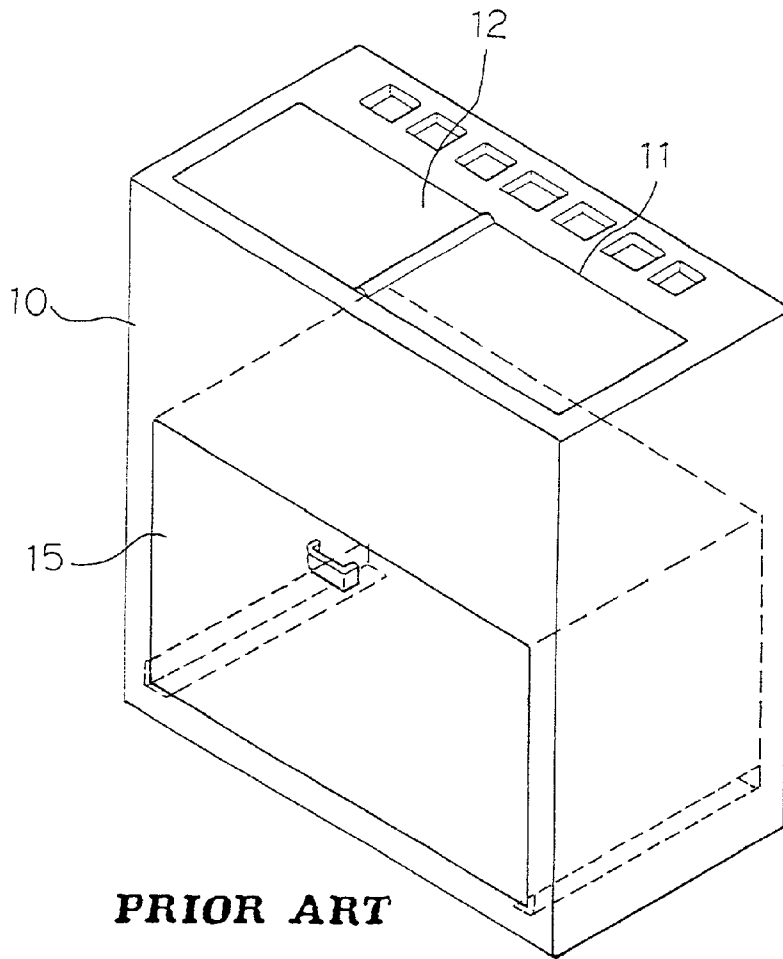

**PRIOR ART**

**FIG. 1**

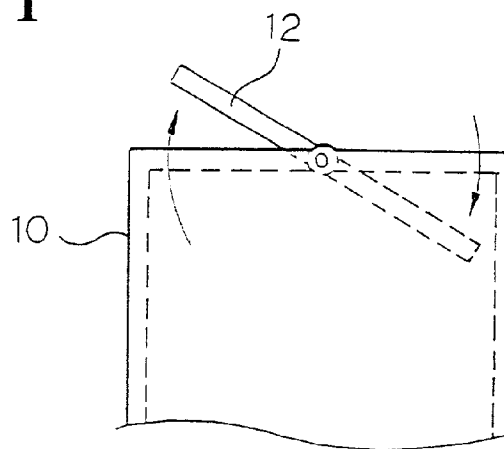

**PRIOR ART**

**FIG. 1A**

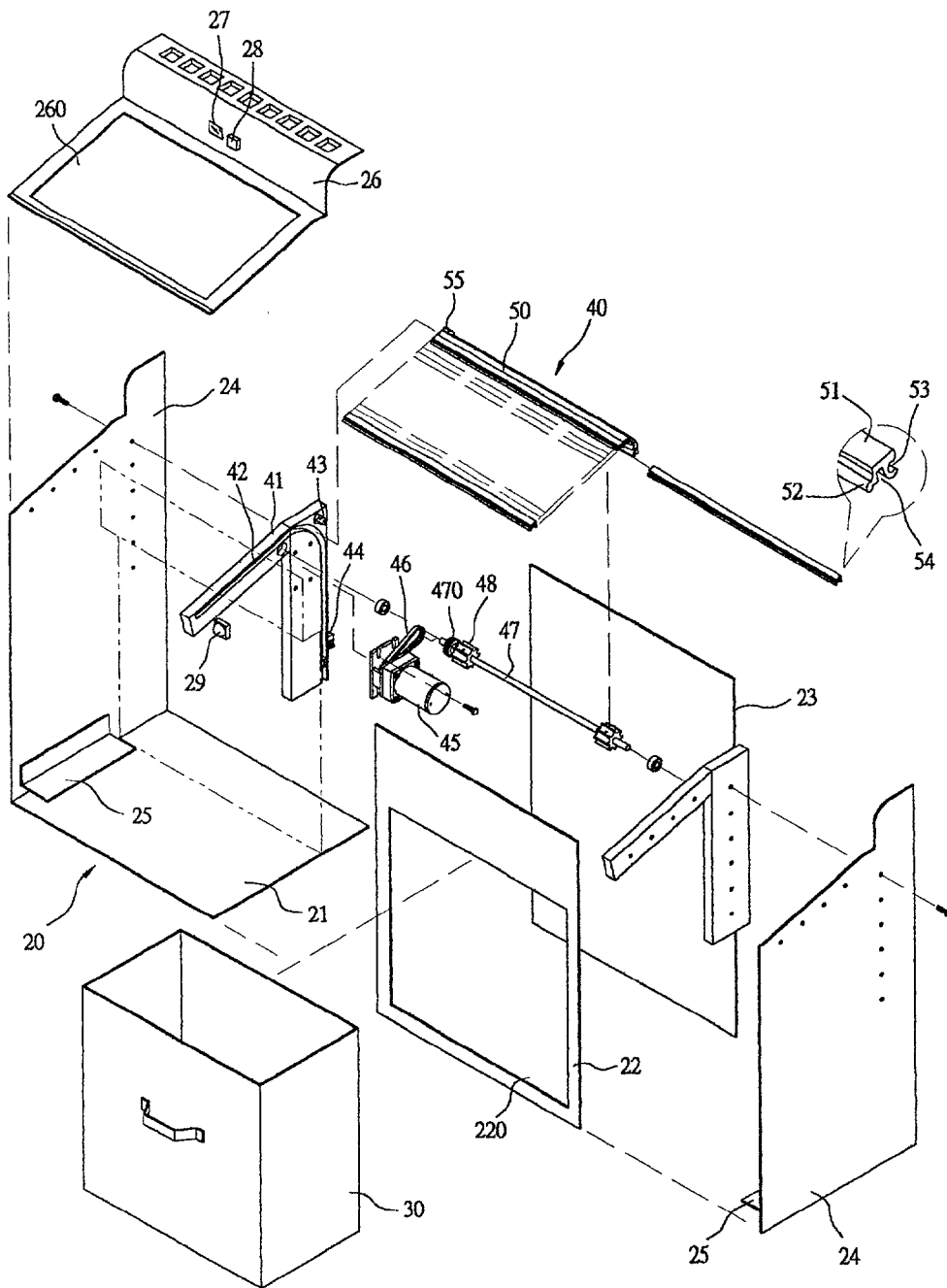

FIG. 2

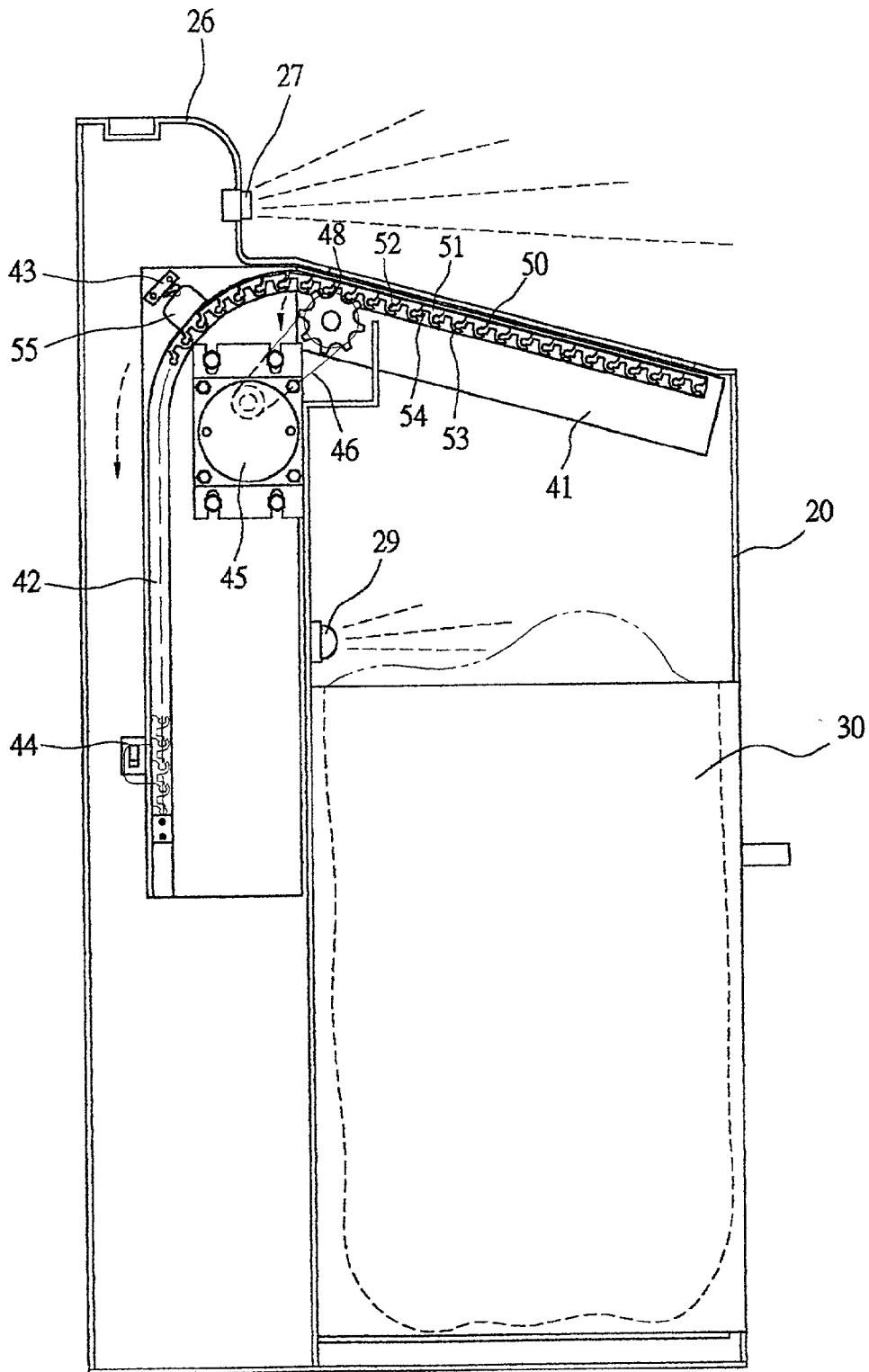
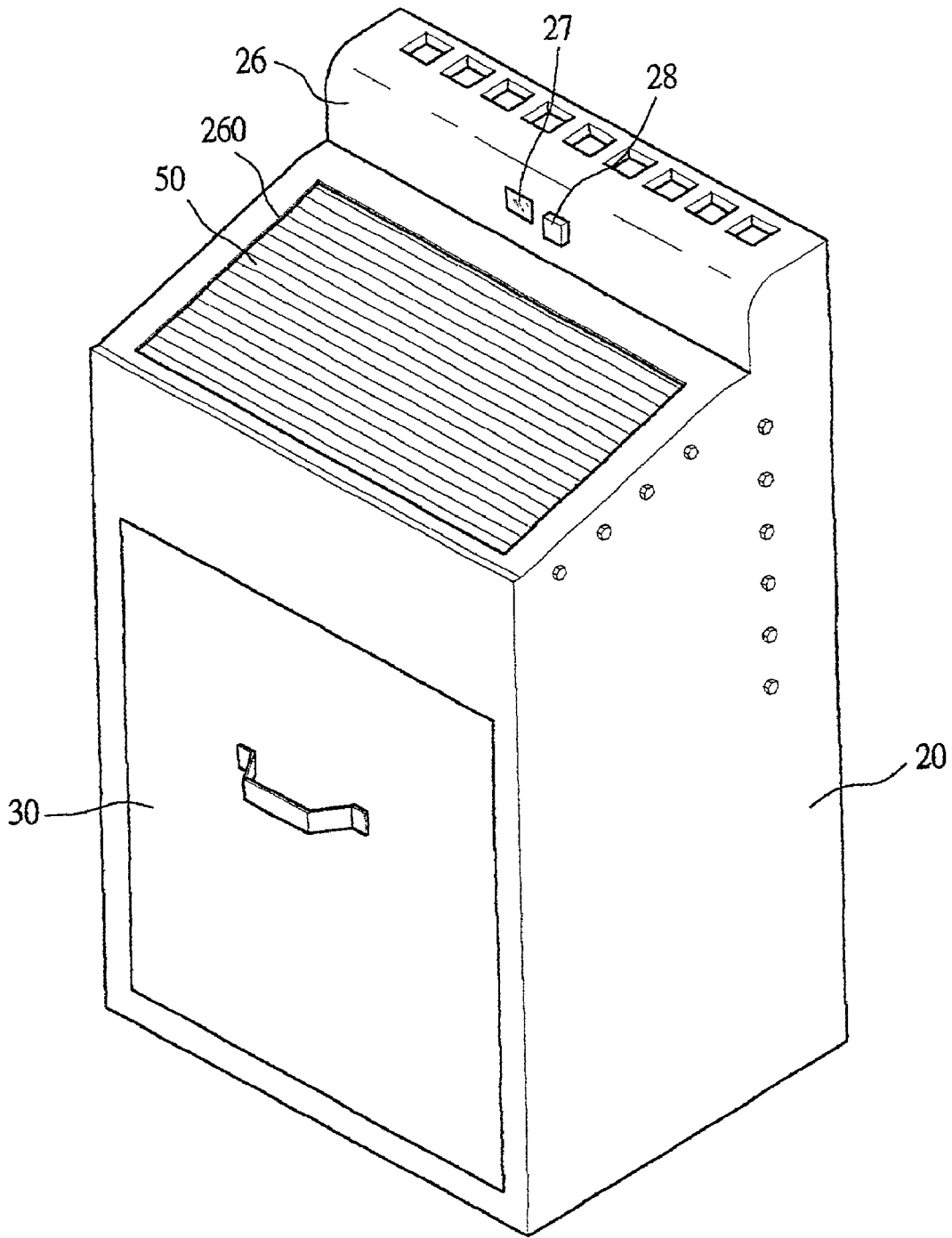

FIG. 3



**FIG. 4**

## STRUCTURE OF A GARBAGE-BOX

### BACKGROUND OF THE INVENTION

[0001] (a) Field of the Invention

[0002] The present invention relates to a garbage-box, and in particular, to a garbage-box having a garbage inlet in combination with a flexible moving door, such that the door can automatically close the garbage inlet or automatically open the garbage inlet.

[0003] (b) Description of the Prior Art

[0004] FIG. 1 shows a conventional large size garbage-box having a hollow container body 10. The top face of the container body 10 is provided with a garbage inlet 11, and a door 12 is pivotally mounted to the garbage inlet 11. The lower section of the container body 10 is provided with a collection container 15 which can be withdrawn from the front lateral side of the container body 10. In operation, the moving door 12 is pushed away and garbage is thrown into the collection container 15 of the container body 10 via the garbage inlet 11. This conventional garbage-box has the following drawbacks

[0005] (1) The collection of garbage is not convenient. The operator has to first open the moving door 12 and the hands of the operator will come into contact with the garbage-box 10. This is inconvenient and not hygienic.

[0006] (2) The moving door cannot be closed under normal operating condition. As the moving door 12 needs a space in order to rotate, if the garbage has been stacked up to the garbage inlet 11, the moving door 12 cannot be opened, or after the moving door is opened, it cannot be closed. Therefore, this conventional garbage structure is inconvenient in operation. In a more serious situation, the bad smell of the garbage will pollute the environment.

[0007] (3) The height of the garbage pile cannot be determined. There is not detection device to measure or to detect the height of stacked garbage. Thus, the piled garbage may cause the moving door 12 from closing and opening, and the overflow of garage will affect the environment. Therefore, the clearing of the garbage is different.

### SUMMARY OF THE INVENTION

[0008] Accordingly, it is an object of the present invention to provide a structure of a garbage-box, having a container body and a collection container, a moving door module being provided to the garbage inlet of the container body, characterized in that, a sensor is provided to the top plate of the container body to sense the approaching of a person to open the moving door on the container body, a further sensor is located within the container body higher than the height of the collection container so as to detect the height of the stacked garbage, on the moving door module, a pair of corresponding inverted L-shaped guiding rail seats are provided at the inner wall of the container body, the guiding rail seat is provided with a corresponding guiding slot, and the top and bottom section of the vertical section of the corresponding guiding slot are provided with a micro-touch switch, and one lateral side of the guiding rail is provided

with a servo motor which can drive a transmission shaft, and the transmission shaft is pivotally mounted to the two guiding rail seats, and the two ends of the transmission shaft are respectively mounted with a zigzag gear to drive a flexible moving door, the bottom end of the flexible moving door, corresponding to the micro-touch switch, is provided with a pushing block so as to sense the opening of the flexible moving door, thereby an improved structure of a garbage-box with a large garbage inlet is formed.

[0009] Other object and advantages of the present invention will become more apparent from the following description taken in conjunction with the accompanying drawings.

### BRIEF DESCRIPTION OF THE DRAWINGS

[0010] FIG. 1 is a schematic view of a conventional garbage-box and the application thereof.

[0011] FIG. 2 is an exploded perspective view of the structure of the garbage-box of the present invention.

[0012] FIG. 3 is a sectional view of the present invention, illustrating the relationship of the elements of the garbage-box of the present invention.

[0013] FIG. 4 is a perspective view of the garbage-box of the present invention.

### DETAILED DESCRIPTION OF THE PRESENT INVENTION

[0014] Referring to FIGS. 2 and 3, there is shown an improved structure of a garbage-box having a garbage inlet 260 on the container body 20, and a collection container 30. On the top of the garbage inlet 260, a moving door module 40 having a flexible moving door 50. The garbage inlet 260 can be automatically closed or opened.

[0015] Again, referring to FIGS. 2 and 3, the container body 20 is provided with a bottom plate 21, and the front and rear edge are respectively provided with a front and rear lateral plates 22, 23. The front lateral plate 22 is provided with a through hole 220 allowing the collection container 30 to pass through. The bottom plate 21 is further provided with two lateral plates 24, and the bottom edge of the lateral plate 24 is provided with sliding rail 25 for the sliding of the collection container 30. The top edges of the lateral plates 22, 23, 24 are joined by a top plate 26 having a garbage inlet 260 to form the container body 20 of the garbage-box. An ashtray is provided at the top plate 26, and a sensor 27 also provided thereto so as to detect the approaching of a person or a button 28 for direct control of the garbage inlet 260 is provided to the top plate 26. Another sensor 29 is provided at the rear lateral plate 23 at a height higher than the position of the collection container 30 to detect the height of the stacked garbage.

[0016] A pair of corresponding inverted L-shaped guiding rail seats 41 are respectively mounted onto the two lateral plates 24, and the guiding rail seat 41 is provided with a corresponding guiding slot 42, and the guiding rail seat 41 corresponding to the top and bottom end of the vertical section of the corresponding guiding slot 42 is provided with the micro-touch switches 43, 44. A servomotor 45 is provided to one lateral side of the guiding rail seat 41, and the transmission shaft 47 of a belted wheel 470 drives the servomotor 45 via a belt 47. The transmission shaft 47 is

pivotally mounted to the two guiding rail seats **41**. The two ends of the transmission shaft **47** are provided with the zigzag gear **48** to drive the flexible moving door **50**.

[0017] The flexible moving door **50** is formed from a plurality of combination rods **51**. The lateral side of the combination rod **51** is provided with a protruded round stripe **52** and an engaging slot **53** so that the adjacent rods **51** can be mounted together and rotatable. The bottom edge of the combination rod **51** has a recessed slot **54** to accommodate the zigzag gear of the transmission shaft **47**.

[0018] A pushing block **55** is provided to the combination rod **51** at the bottom end of the flexible moving door **50**. This pushing block **55** corresponds to the micro-touch switches **43, 44** so as to detect the opening or closing of the flexible moving door **50**. Therefore, an improved garbage-box having a large garbage inlet **260** is obtained.

[0019] As shown in FIGS. 3 and 4, in operation, if a user approaches the garbage-box the sensor **27** detects the user and the servomotor **45** is initiated to move the transmission shaft **47**. The zigzag gear **48** of the transmission shaft **47** drives the flexible moving door **50**. The door **50** slides downward along the guiding slot **42** of the guiding rail seat **41** and stops when the push block **55** touches the micro-touch switch **44** for the user to discard garbage.

[0020] When the user leaves the garbage-box, the servomotor **45** moves in a reverse direction and the flexible moving door **50** moves upward to close until the push block **55** touches the other micro-touch switch **43**. The user can control the door **50** by using the control button **28** on the garbage-box. The sensor **29** within the container body **20** detects the height of the stacked garbage.

[0021] The advantages of the present invention are as follows:

[0022] (1) The garbage inlet of the garbage-box is extended. As the door **50** can be closed or opened along the inner wall of the container body, the space required for the top plate **26** is greatly reduced. Thus, the garbage inlet **260** on the top plate **26** can be enlarged, allowing the user to conveniently discard garbage.

[0023] (2) Longevity of Motor. As a zigzag gear **48** is utilized in the transmission shaft **47** to direct control the door **50**. The transmitted force is great and the speed is fast. Thus, the power needed is lesser and the cost of operation is reduced. Further, the longevity of the motor is extended.

[0024] While the invention has been described with respect to preferred embodiment, it will be clear to those skilled in the art that modifications and improvements may be made to the invention without departing from the spirit and scope of the invention. Therefore, the invention is not to be limited by the specific illustrative embodiment, but only by the scope of the appended claims.

I claim:

1. A structure of a garbage-box having a container body and a collection container, a flexible moving door module being provided to the garbage inlet of the container body, characterized in that,

a sensor is provided to a top plate of the container body to sense the approaching of a person to open the moving door on the container body, a further sensor is located within the container body at a position higher than the height of the collection container so as to detect the height of the stacked rubbish, on the moving door module, a pair of corresponding inverted L-shaped guiding rail seats are provided at the inner wall of the container body, the guiding rail seat is provided with a corresponding guiding slot, and the top and bottom section of the vertical section of the corresponding guiding slot are provided with a micro-touch switch, and one lateral side of the guiding rail is provided with a servo motor which can drive a transmission shaft, and the transmission shaft is pivotally mounted to the two guiding rail seats, and the two ends of the transmission shaft are respectively mounted with a zigzag gear to drive flexible moving door, the bottom end of the flexible moving door, corresponding to the micro-touch switch, is provided with a pushing block so as to sense the opening of the flexible moving door, thereby an improved structure of a garbage-box with a large garbage inlet is formed.

2. The structure of a garbage-box of claim 1, wherein the top face of the container body is provided with controlling buttons for direct controlling so as to replace the electronic sensors.

3. The structure of a garbage-box of claim 1, wherein the flexible moving door is formed from a plurality of combination rods, the two lateral sides of each rod are formed into corresponding protruded rounded engaging stripe and engaging slot such that the adjacent combination rod is pivotally combined and is rotatable, and the bottom edge of the combination rod is formed into a recess to accommodate the zigzag gear of the transmission shaft.

\* \* \* \* \*