

(19) World Intellectual Property Organization
International Bureau



(43) International Publication Date
12 September 2002 (12.09.2002)

PCT

(10) International Publication Number
WO 02/070849 A1

(51) International Patent Classification⁷: E05F 15/20,
B65F 1/16, A01K 5/01, 5/02

(21) International Application Number: PCT/GB02/01018

(22) International Filing Date: 7 March 2002 (07.03.2002)

(25) Filing Language: English

(26) Publication Language: English

(30) Priority Data:
0105713.2 7 March 2001 (07.03.2001) GB

(71) Applicant and

(72) Inventor: WINTER, Cyril, Edward [GB/GB]; 3 Poplar Avenue, Markfield, Leicestr LE67 9WP (GB).

(74) Agent: DEARING-LAMBERT, Peter, Richard; 109 High Street, Ibstock, Leicestershire LE67 6LJ (GB).

(81) Designated States (national): AE, AG, AL, AM, AT, AU, AZ, BA, BB, BG, BR, BY, BZ, CA, CH, CN, CO, CR, CU,

CZ, DE, DK, DM, DZ, EC, EE, ES, FI, GB, GD, GE, GH, GM, HR, HU, ID, IL, IN, IS, JP, KE, KG, KP, KR, KZ, LC, LK, LR, LS, LT, LU, LV, MA, MD, MG, MK, MN, MW, MX, MZ, NO, NZ, OM, PH, PL, PT, RO, RU, SD, SE, SG, SI, SK, SL, TJ, TM, TN, TR, TT, TZ, UA, UG, US, UZ, VN, YU, ZA, ZM, ZW.

(84) Designated States (regional): ARIPO patent (GH, GM, KE, LS, MW, MZ, SD, SL, SZ, TZ, UG, ZM, ZW), Eurasian patent (AM, AZ, BY, KG, KZ, MD, RU, TJ, TM), European patent (AT, BE, CH, CY, DE, DK, ES, FI, FR, GB, GR, IE, IT, LU, MC, NL, PT, SE, TR), OAPI patent (BF, BJ, CF, CG, CI, CM, GA, GN, GQ, GW, ML, MR, NE, SN, TD, TG).

Published:

— with international search report

For two-letter codes and other abbreviations, refer to the "Guidance Notes on Codes and Abbreviations" appearing at the beginning of each regular issue of the PCT Gazette.

(54) Title: APPARATUS FOR THE AUTOMATIC CONTROL OF A HINGED LID OF A RECEPTACLE

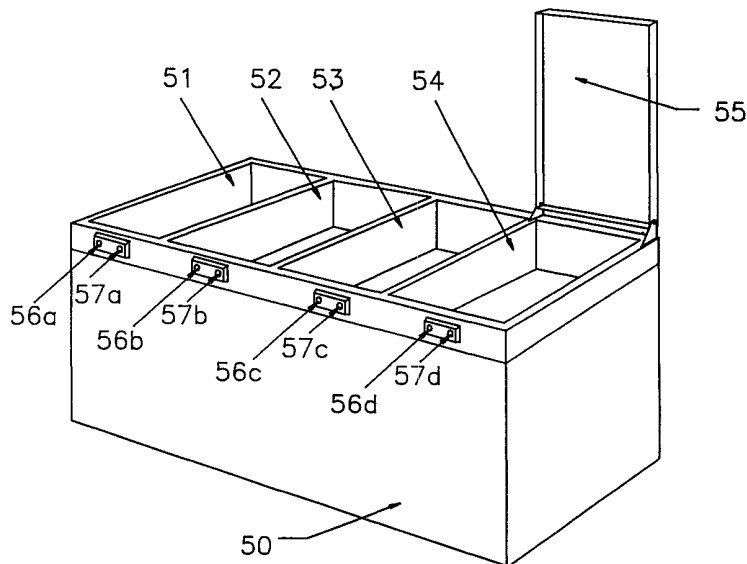

(57) Abstract: The hinged lid of a receptacle such as a food counter or pet feeder opens automatically when an infra red beam in front of the receptacle is interrupted. Either a narrow infra red beam is emitted parallel with the front of the receptacle or a diffused beam is emitted away from the front of the receptacle and a voltage comparator is used to open the lid when a predetermined amount of infra red is reflected from a person or animal approaching the receptacle corresponding with a chosen proximity and position of the person or animal. Plural receptacles may have a common lid opening mechanism in the form of a constantly rotated shaft which engages a cam associated with each lid when an electromagnetic clutch is actuated by interruption of a beam associated with each receptacle.

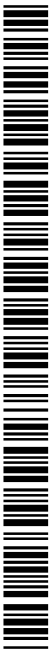

WO 02/070849 A1

APPARATUS FOR THE AUTOMATIC CONTROL OF A HINGED LID OF A RECEPTACLE.

This invention relates to apparatus for the automatic control of a hinged lid of a receptacle.

There are many situations in which it is desirable that a hinged lid should open automatically as a user approaches and should close as the user moves away. Such "hands free" operation of a lid would be useful, for example, for a tool box as the user's hands may be otherwise occupied. In the medical field there would be benefits of hygiene as the user would not have to touch the lid.

Lids or covers are advantageous for receptacles for substances which will spoil if exposed to the air or which must be kept hot or cold. An example of the former is an artists pallet. A cover or lid will inhibit drying out of the paints but the artist will not want the trouble of lifting or removing a lid every time he wishes to refresh his brush.

Lids or covers are particularly desirable for receptacles for perishables, particularly food and drink for human and animal consumption.

In restaurants, supermarkets and other outlets food and drink are presented in open-topped trays or cabinets from which they are taken by customers or by catering or serving staff. In self-service establishments diners or customers serve themselves to selected items. Some form of sneeze-guard or cover should be provided for reasons of hygiene, but this inevitably causes some inconvenience. A typical sneeze-guard is a fixed dome of a transparent plastics material elevated above the food and drink containers so that users can reach in through the slot between the dome and the containers. With this form of protector there is permanent exposure of the perishables to the atmosphere. Alternatively a removable or hinged lid may be provided which, when closed, fully isolates the perishables from the atmosphere but such lids are a cause of inconvenience and delay to users who have no spare hand to lift them. Typically a diner or customer will be carrying a tray or a basket in one hand and needs the other hand to serve with. Removing or lifting and lowering a lid is therefore an awkward operation and in practice lids will simply be left off or left open.

One object of the present invention is to overcome these problems by providing a hinged lid or cover which will open automatically as a user approaches and will close automatically when he or she moves away. Such covers will provide better protection than a fixed sneeze guard without the drawbacks of removable or manually operated hinged covers.

Another object of the present invention is to provide a covered or lidded food or drink receptacle for a small animal such as a cat which will open only when the animal approaches to feed or drink and will close again when the animal moves away.

Pet cats, of which there are millions in the United Kingdom alone, are notoriously fickle and selective feeders. Unlike dogs, and except when very hungry, they tend not to wolf down all of the food when a plate is put down for them. Instead they may eat only a little, and then return at erratic intervals to eat more. Once the food becomes dry or stale they will leave it. Because a cat's appetite is unpredictable owners tend to put out far more food than the cat will consume at one time, resulting in excessive waste. Unattended cat food is unhygienic, smells and attracts flies and other vermin.

So that rationed amounts of food can be presented in a fairly fresh condition at pre-selected meal times automatically during a pet owner's absence there have been a number of proposals for devices which will uncover in a timed sequence portions of food previously placed in receptacles. Such devices have the merit that an excess of food remains covered until meal times specified by the owner but do not allow for the fact that cats, in particular, wish to eat at erratic intervals and even when hungry will spurn food which has been uncovered for too long. In general such devices will retain quantities of unconsumed food, will refuse food or drink when the cat wants it and will expose it at times when the cat has no interest in it.

WO 97/31525, US-A-5669328 and US-A-6044795 exemplify prior art devices which will present food and drink "on demand", i.e. they are normally closed but respond to the proximity of an animal. None provides an ideal solution to the problem. WO 97/31525 relies on a pet stepping onto a treadle. Animals will not reliably do this and of course vary considerably in weight, so that either the machine must be unduly sensitive or it will

fail to open if insufficient weight is applied to the treadle. In US-A-5669328 the pet must carry a transmitter and in US-A-6044795 the pet has an implanted tag. It is obviously undesirable that an animal should have to wear an actuator or have one implanted.

A principal object of the pet feeder embodiment of the present invention is to improve upon prior art proposals by providing a system which is fully independent of the weight of the animal but in which the pet need not carry or have implanted any extraneous item such as a transmitter, tag or magnet.

In accordance with the invention there is provided apparatus for the automatic control of a hinged lid of a receptacle, comprising means for emitting a beam of radiant energy in front of the receptacle, means for opening the lid in response to a predetermined interruption of the beam and means for closing the lid or allowing the lid to close when said interruption ceases.

In a first embodiment of the present invention said opening means comprises means for emitting from the front of the receptacle a diffused infra red beam and scanning means which generates a voltage proportional to the position and proximity of an object interrupting and reflecting the beam so that said opening means opens the lid in response to generation by the scanning means of a predetermined voltage corresponding to a predetermined position of said object in front of the receptacle.

In a second embodiment of the present invention an emitter and a receiver for a narrow infra red beam are mounted so that the beam is in front of and at a predetermined spacing from and generally parallel with the front of the receptacle, said opening means responding to interruption of the beam.

In either embodiment there is preferably further provided timer means which delays closure of the lid for a predetermined time interval after said interruption of the beam ceases.

In the second embodiment the emitter and receiver may be mounted so that the beam is horizontal and at a predetermined height above the ground. The emitter and receiver may be mounted on respective barriers which extend in

front of the receptacle spaced apart along the length of the receptacle, the barriers serving to encourage a person or animal to approach the receptacle in a direction such as to interrupt the beam.

When the second embodiment of the invention is in the form of a pet feeder the barriers may be frontal extensions of parallel side walls of the receptacle. The extensions preferably rise above the receptacle and have slots to serve as carrying handles.

The receptacle may be generally rectangular and the cover or lid may be hinged to pivot about an axis parallel with and in the region of the back of the receptacle, the extensions being from the front of the receptacle.

The opening means may comprise a worm gear driven by an electric motor, the worm gear engaging teeth of a quadrant extending from the cover or lid. Limit switches are preferably provided which deactivate the motor when the cover or lid is in a fully open or a fully closed position.

Alternatively the opening means may comprise a cam driven by an electric motor to cause arcuate movement of a member extending from the lid to open the same. A clutch may be provided which responds to interruption of the beam to connect the cam to a shaft constantly rotated by the electric motor, means being provided to disengage the clutch when the cam has performed half a revolution.

Plural receptacles may be provided having respective hinged lids controlled by respective cams each of which is selectively connectable to the shaft by a respective clutch when a respective beam is interrupted.

The or each said cam may be circular and mounted eccentrically to its axis of rotation, the cam being mounted within a yoke pivoted at one end so as to move angularly to and fro as the cam rotates, said member being a fork depending from the lid within which a pin at the other end of the yoke is captive, the fork being rotatable about a mounting intermediate the lid and pin such that the fork lifts and lowers the lid as the cam rotates.

The or each clutch is preferably capable of slipping to compensate for any misalignment between the lid and the cam.

Preferred embodiments of the invention will now be described by way of non-limitative example with reference to the accompanying drawings, in which:

- Figure 1 is a perspective view of a pet feeder having an automatically opening lid in accordance with the invention;
- Figure 2 is an internal detail of the feeder of Figure 1;
- Figure 3 is a block diagram of an infra red scanner which can be used for the pet feeder of Figures 1 and 2 or the counter of Figure 5;
- Figure 4 is a plan view of a counter of a self-service buffet or the like food station of a shop or restaurant;
- Figure 5 is a perspective view of an alternative counter;
- Figure 6 diagrammatically illustrates in front elevation a lid opening and closing mechanism which can be utilised in the pet feeder of Figure 1 in place of the mechanism of Figure 2 or in either of the counters of Figures 4 and 5;
- Figure 7 is a view taken on the line VII-VII of Figure 6, and
- Figures 8-10 illustrate the operation of the mechanism of Figures 6 and 7

The pet feeder 10 illustrated in Figures 1 has a generally rectangular housing 11 suitably formed by moulding a plastics material to have two upwardly opening well-like formations 12, 12' in which respective dishes or bowls (not shown) may be placed to contain food or drink for a pet animal such as a cat. The feeder has a lid or cover 13 which is hinged at 14 to the back of the housing 11 so that it can move between the fully open position in which it is shown in Figure 1 and a fully closed, horizontal position in which it will cover the contents of the bowls. In doing so the lid 13 moves between walls 15, 15' which rise above parallel sides of the housing 11 and extend beyond its front for a purpose to be described. The walls 15, 15' discourage an animal from approaching from the sides of the housing 11 and are formed with slots 16, 16' which serve as carrying handles. Thus if the feeder is, in use, placed with its back to a wall or other obstruction an animal is encouraged to approach only to the front of the feeder, where it will pass between the extensions of the walls 15, 15'.

These carry at their distal ends at similar positions above ground level respectively an emitter 17 and a receiver 18 for an infra red beam. As is known per se in burglar alarms the beam is preferably narrow and of a wavelength beyond the spectral response of the human eye and therefore

invisible. As an animal approaches to feed it will interrupt the beam and as it moves away it will cease to interrupt the beam. Electronics 19 on a board 20 (Figure 2) forming the underside of the housing 11 respond to interruption of the beam by energising an electric motor 21 from a battery 22 so that the motor rotates a worm gear 23 in a sense such that teeth 24 engaged by the worm gear and on an arcuate edge of a quadrant 25 fixed to the lid 13 cause the lid to rise to the fully open position in which it is shown in Figure 1. The lid will remain open as long as the feeding animal continues to interrupt the beam. When the animal moves away after feeding it ceases to interrupt the beam. The electronics 19 sense the re-establishment of the beam and respond by counter-rotating the motor 21 so that the lid 13 is closed. Preferably a time delay, say of 15 seconds, is built into the electronics 19 so that the motor 21 is not started immediately the beam is re-established in case the animal hesitates and returns to the feeder.

Preferably the emitter 17 is pulsed with a burst of 40khz energy every 1 second for a duration of 1 millisecond. This will reduce the drain on the battery 22 and interference from other sources of infra red such as fluorescent lights and sunlight.

Limit switches (not shown) may be provided to de-activate the motor 21 when the lid 13 reaches either its fully open or its fully closed position. If the lid 13 is sufficiently weighted it may be unnecessary positively to drive it to its closed position, gearing between the motor 21 and the lid 13 simply being disengaged to allow this to happen.

The motor 21, worm gear 23 and quadrant 25 could be replaced by a crank and connecting rod acting on the lid 13.

In an alternative embodiment of the pet feeder of Figure 1 the emitter 17 and receiver 18 on the extensions of the walls 15, 15' are replaced by an emitter 26 and a receiver 27 on the front 28 of the housing 11. The emitter 26 emits a diffused beam of infra red from the front 28 of the housing. When the diffused beam is interrupted by an object the infra red is reflected back to the receiver 27. In this embodiment the electronics 19 include the items illustrated in block diagram in Figure 3. Reflected infra red is continuously monitored by a scanning means in the form of a voltage comparator. This is adjustable to output current to the motor 21

only when reflected infra red is of a predetermined value corresponding to a predetermined position of an object in front of the housing 11. Remote objects will not reflect back to the receiver 27 sufficient infra red to trigger the voltage comparator, so that the lid 13 will not open simply in response e.g. to someone walking past the pet feeder or a flapping curtain. On the other hand the close proximity of an object will reflect sufficient infra red to trigger the comparator even if the object is not highly reflective as in the case of the fur of a cat.

Equipment of this kind is known *per se* and is commercially available from the Sharp organisation.

Figure 4 illustrates the application of the present invention to a counter 30 having plural receptacles (not shown) for food and/or drink for human consumption. The receptacles are normally covered by respective lids 31, 32, 33 and 34 which are hinged at the rear of the counter. As is known *per se* the lids may be of transparent material so that the contents of the receptacles can be viewed even when the lids are closed.

The counter 30 is located in a recess in a wall 35, the recess being slightly deeper than the counter so that the sides of the recess extend in front of the counter. Between each adjacent pair of receptacles a barrier 36, 37 and 38 extends from the front of the counter 30. An emitter 39 for a narrow infra red beam is mounted on the side wall 48 of the recess where this extends beyond the counter 30 and at a suitable height above the ground. A receiver 40 is positioned on the side of the barrier 36 confronting the side wall 48 in horizontal alignment with the emitter 39. On the other side of the barrier 36 is an emitter 41 aligned with a receiver 42 on the confronting side of the barrier 37 and likewise the barriers 37 and 38 have respectively an emitter 43 and a receiver 44. Finally a receiver 45 is positioned on the side wall 46 of the recess where this extends beyond the counter 30 and in alignment with an emitter 47 on the confronting side of the barrier 38.

Persons wishing to access the receptacles must therefore approach the front of the counter 30. To gain access to a chosen one of the receptacles the respective beam is interrupted either by the body of the person or by moving a hand or a serving implement through the selected beam.

Instead of locating the counter 30 in a recess it may have integral barriers (not shown) at its opposite ends.

Figure 5 illustrates a counter 50 having in its top four receptacles 51, 52, 53 and 54. A respective lid hinged at the back of the counter (only one being shown at 55 for simplicity) will, when closed, cover each of the receptacles. In the front of the counter are four paired emitters and receivers 56a,57a, 56b,57b, 56c,57c and 56d,57d each pair associated and aligned with a respective one of the receptacles 51-54. Each emitter 56 emits a diffused infra red beam from the front of the counter 50. Within the counter 50 there are electronics such as exemplified by Figure 3. The voltage comparator associated with each receiver 57 will cause lifting of the associated lid only when the intensity of infra red from the associated emitter 56 reflected back to it from a person or object in front of the counter 50 corresponds with a pre-selected proximity and position of that person or object. The sensitivity of the comparator can be adjusted to ensure that only the lid of the receptacle 51-54 in front of which the person is standing will open and not the lids of adjacent receptacles 51-54.

A preferred mechanism for opening and closing the lids of the receptacles of the counter of Figure 4 or the counter of Figure 5 is illustrated in Figures 6-10.

A shaft 60 positioned horizontally at the rear of the counter and extending substantially its full width is continuously slowly rotated by an electric motor 61 through gearing 62. Associated with each lid of the counter is a respective electromagnetic clutch 63 which can engage a respective, eccentrically mounted circular cam 64 with the shaft 60 or disengage the cam 64 from the shaft 60. Each clutch 63 is under the control of the respective infra red beam and engages when the beam is interrupted and disengages (after a suitable interval) when interruption of the beam ceases.

Each cam 64 rotates in a slot 65 in a yoke 66 which is pivotally mounted at 67 at its lower end so that as the cam 64 rotates the yoke 66 oscillates between the positions of Figures 8 and 10. A fork 68 is fixed to the associated lid and is rotatable about a horizontal axis at 69. A pin 70

at the upper end of the yoke 66 is captive in the fork 68 so that as the yoke 66 oscillates it swings the fork 68 and opens and closes the lid.

Figure 10 illustrates the lid-closed position. When the associated beam is interrupted the clutch 63 is engaged only long enough to cause half a revolution of the cam 64. This causes the fork 68 to move through the position of Figure 9 to the position of Figure 8, the lid now being fully open. When interruption of the beam ceases the clutch 63 is again engaged, after a suitable time interval, only long enough to cause another half-revolution of the cam 64. The cam 64 will thus move through the position of Figure 9 to the position of Figure 10 in which the lid is fully closed.

Slippage of the clutch 63 will self-correct any misalignment which may arise between the lid and the cam and will prevent any possible injury to a person whose hand is under the lid when it closes. The next time the lid is opened it will be stopped at the fully open position while the cam 64 continues to the position of Figure 8. Likewise if a lid is pulled from the fully open position it will be stopped at the fully closed position until the cam reaches the position of Figure 10.

CLAIMS:

1. Apparatus for the automatic control of a hinged lid (13,31,32,33,34,55) of a receptacle (11,30,50), characterised in that it comprises means (17,26,39,41,43,47,56) for emitting a beam of radiant energy in front of the receptacle, means (25,60) for opening the lid in response to a predetermined interruption of the beam and means (25,60) for closing the lid or allowing the lid to close when said interruption ceases.
2. Apparatus as claimed in claim 1, characterised in that said opening means comprises means (26,56) for emitting from the front of the receptacle (11,50) a diffused infra red beam and scanning means which generates a voltage proportional to the position and proximity of an object interrupting and reflecting the beam and in that said opening means (25,60) opens the lid in response to generation by the scanning means of a predetermined voltage corresponding to a predetermined position of said object in front of the receptacle (11,50).
3. Apparatus as claimed in claim 1, characterised in that an emitter (17,39,41,43,47) and a receiver (18,40,42,44,45) for a narrow infra red beam are mounted so that the beam is in front of and at a predetermined spacing from and generally parallel with the front of the receptacle (11,30), and in that said opening means (25,60) responds to interruption of the beam.
4. Apparatus as claimed in any one of the preceding claims characterised in that it further comprises timer means which delays closure of the lid (13,31,32,33,34,55) for a predetermined time interval after said interruption of the beam ceases.
5. Apparatus as claimed in claim 3, or claim 4 as appendant to claim 3, characterised in that the emitter (17,39,41,43,47) and receiver (18,40,42,44,45) are mounted so that the beam is horizontal and at a predetermined height above the ground.
6. Apparatus as claimed in claim 5, characterised in that the emitter (17,39,41,43,47) and receiver (18,40,42,44,45) are mounted on respective barriers (15,15',31,36,37,38,46) which extend in front of the receptacle (11,30) spaced apart along the length of the receptacle, the barriers

serving to encourage a person or animal to approach the receptacle in a direction such as to interrupt the beam.

7. Apparatus as claimed in claim 5 characterised in that it is in the form of a pet feeder (10) wherein the barriers (15,15') are frontal extensions of parallel side walls of the receptacle.

8. Apparatus as claimed in claim 7, characterised in that the extensions (15,15') rise above the receptacle (11) and have slots (16,16') to serve as carrying handles (A)..

9. Apparatus as claimed in any one of claims 5-8 characterised in that the receptacle (11,30) is generally rectangular and the cover or lid (13,31,32,33,34) is hinged to pivot about an axis parallel with and in the region of the back of the receptacle (11,30), the extensions (15,15',31,36,37,38,46) being from the front of the receptacle (11,30).

10. Apparatus as claimed any one of the preceding claims, characterised in that the opening means comprises a worm gear (23) driven by an electric motor (21), the worm gear engaging teeth (24) of a quadrant (25) extending from the cover or lid (13).

11. Apparatus as claimed in claim 10 characterised in that it comprises limit switches which deactivate the motor (21) when the cover or lid (13) is in a fully open or a fully closed position.

12. Apparatus as claimed in any one of claims 1-9, characterised in that the opening means comprises a cam (64) driven by an electric motor (61) to cause arcuate movement of a member (68) extending from the lid to open the same.

13. Apparatus as claimed in claim 12, characterised in that a clutch (63) responds to interruption of the beam to connect the cam (64) to a shaft (60) constantly rotated by the electric motor (61), means being provided to disengage the clutch when the cam (64) has performed half a revolution.

14. Apparatus as claimed in claim 13 characterised in that plural receptacles (51,52,53,54) are provided having respective hinged lids (55) controlled by respective cams (64) each of which is selectively connectable

to the shaft (60) by a respective clutch (63) when a respective beam is interrupted.

15. Apparatus as claimed in claim 13 or claim 14, characterised in that the or each said cam (64) is circular and mounted eccentrically to its axis of rotation, the cam being mounted within a yoke (66) pivoted at one end (67) so as to move angularly to and fro as the cam (64) rotates, said member being a fork (68) depending from the lid within which a pin (70) at the other end of the yoke (66) is captive, the fork (68) being rotatable about a mounting (69) intermediate the lid and pin (70) such that the fork (68) lifts and lowers the lid as the cam (64) rotates.

16. Apparatus as claimed in claim 14 or claim 15, characterised in that the or each clutch (63) is capable of slipping to compensate for any misalignment between the lid and the cam (64).

1/7

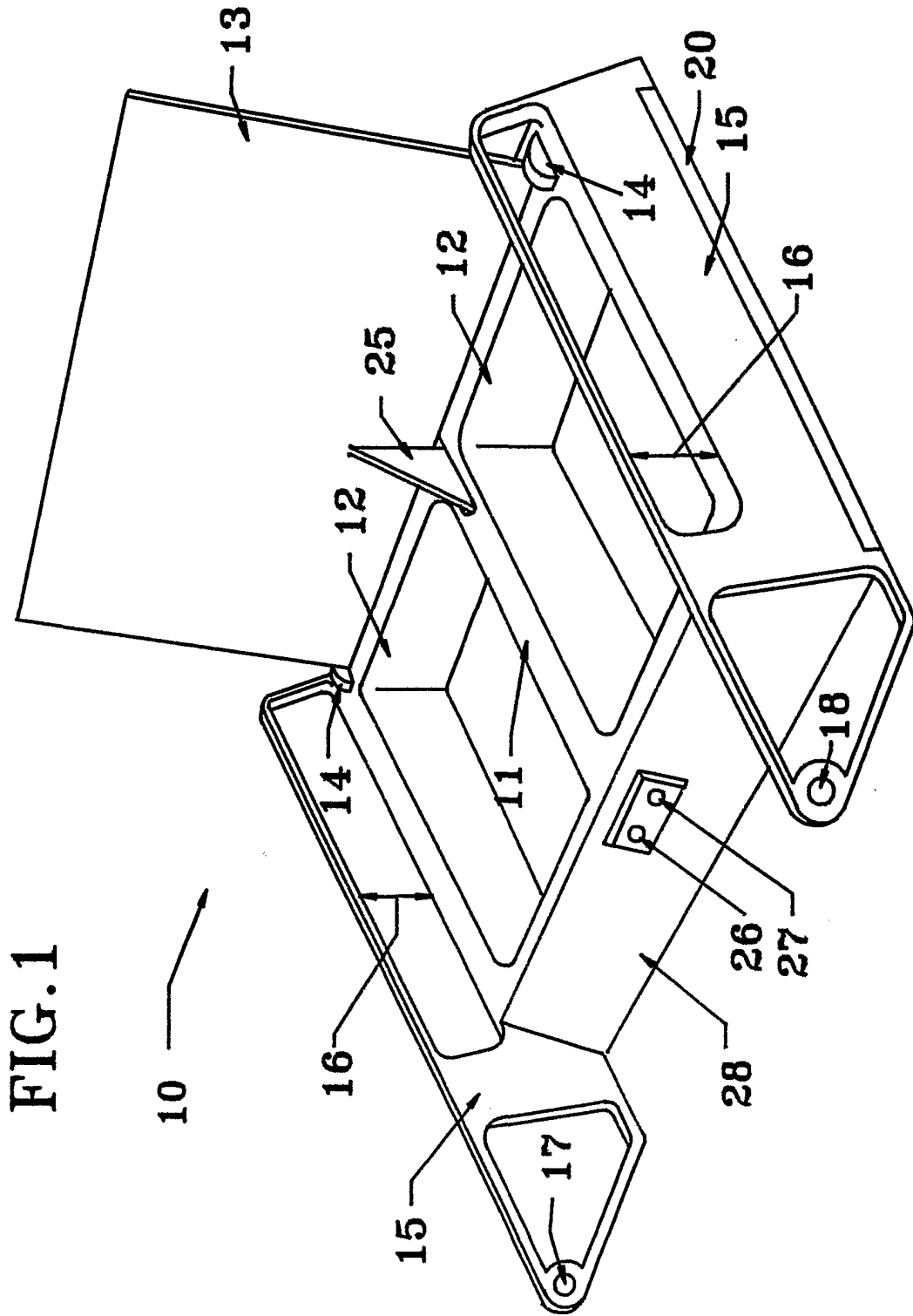

FIG. 1

2/7

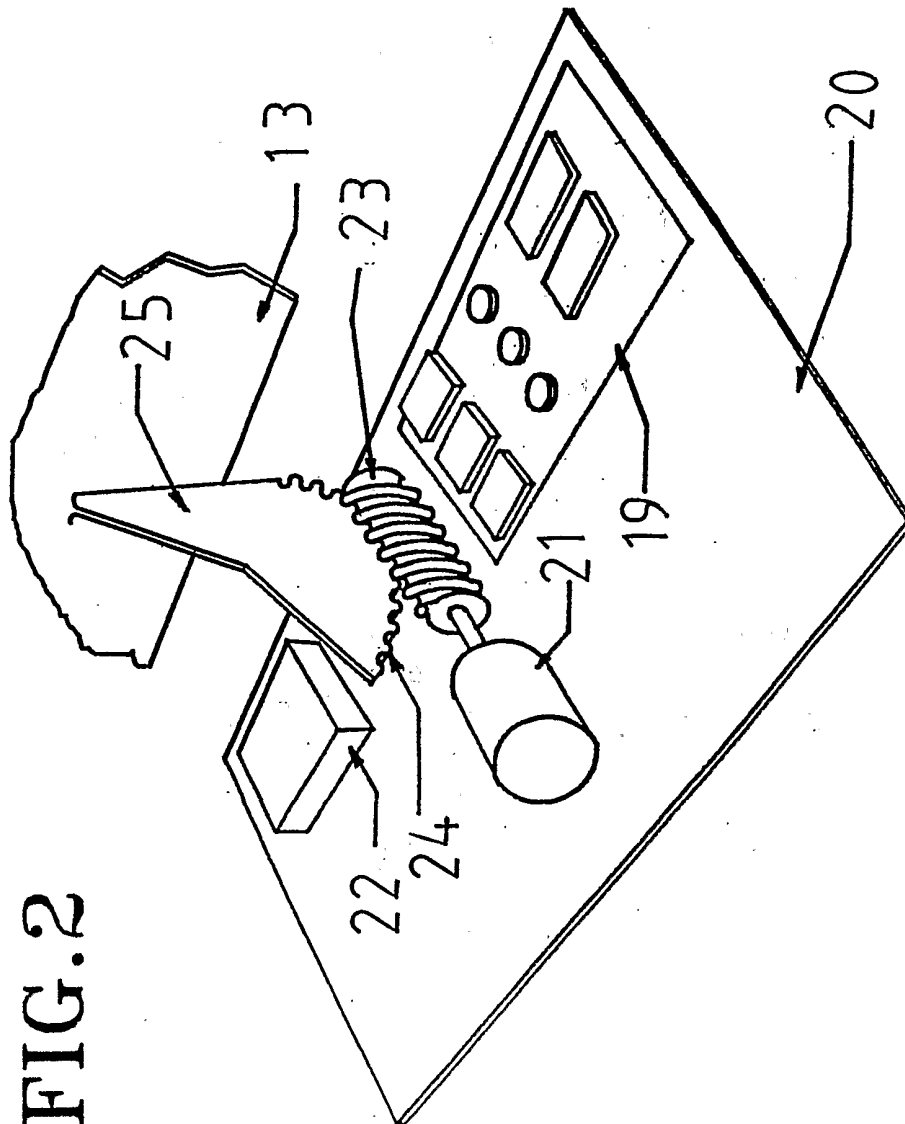
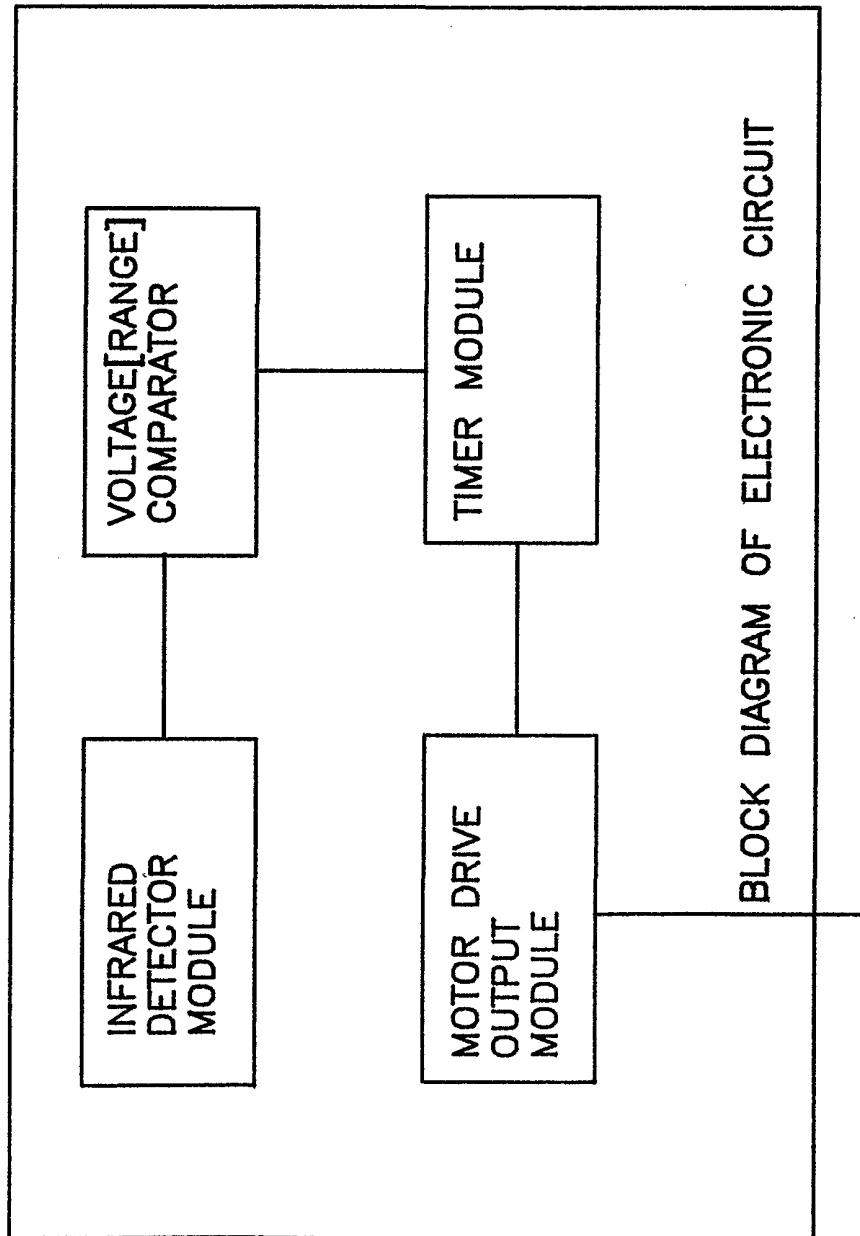

FIG. 2

3/7

FIG.3



4/7

FIG. 4

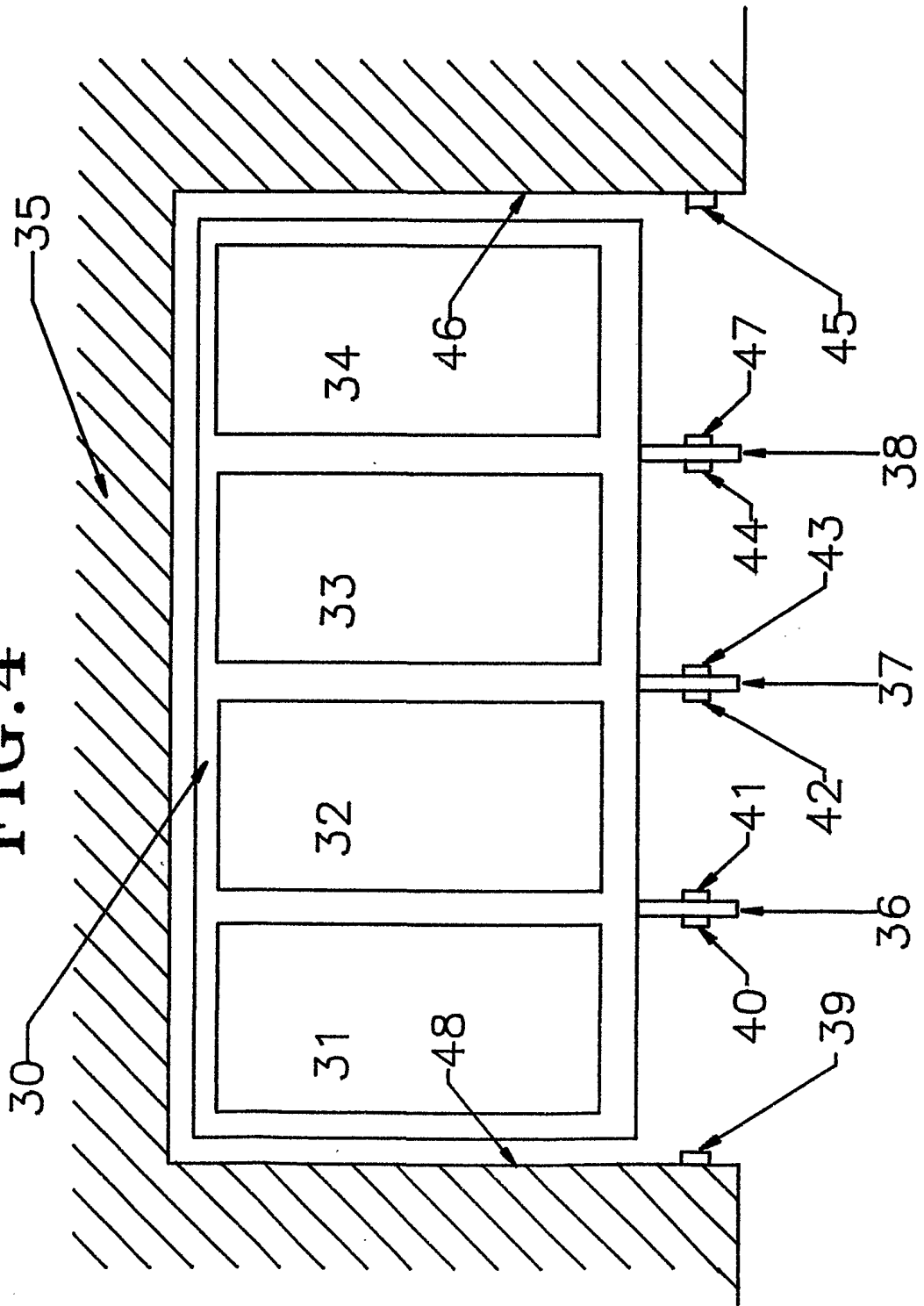

5/7

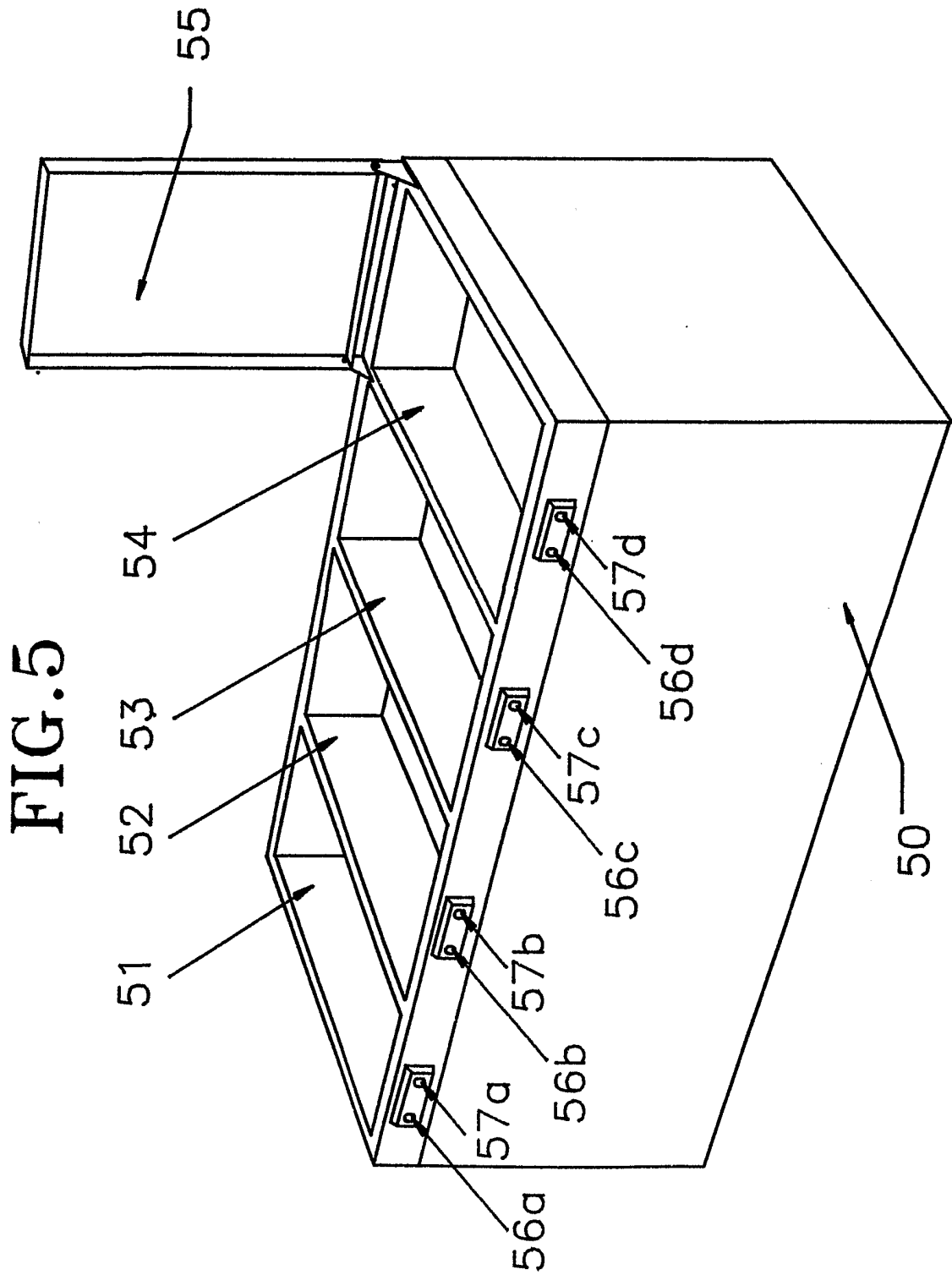

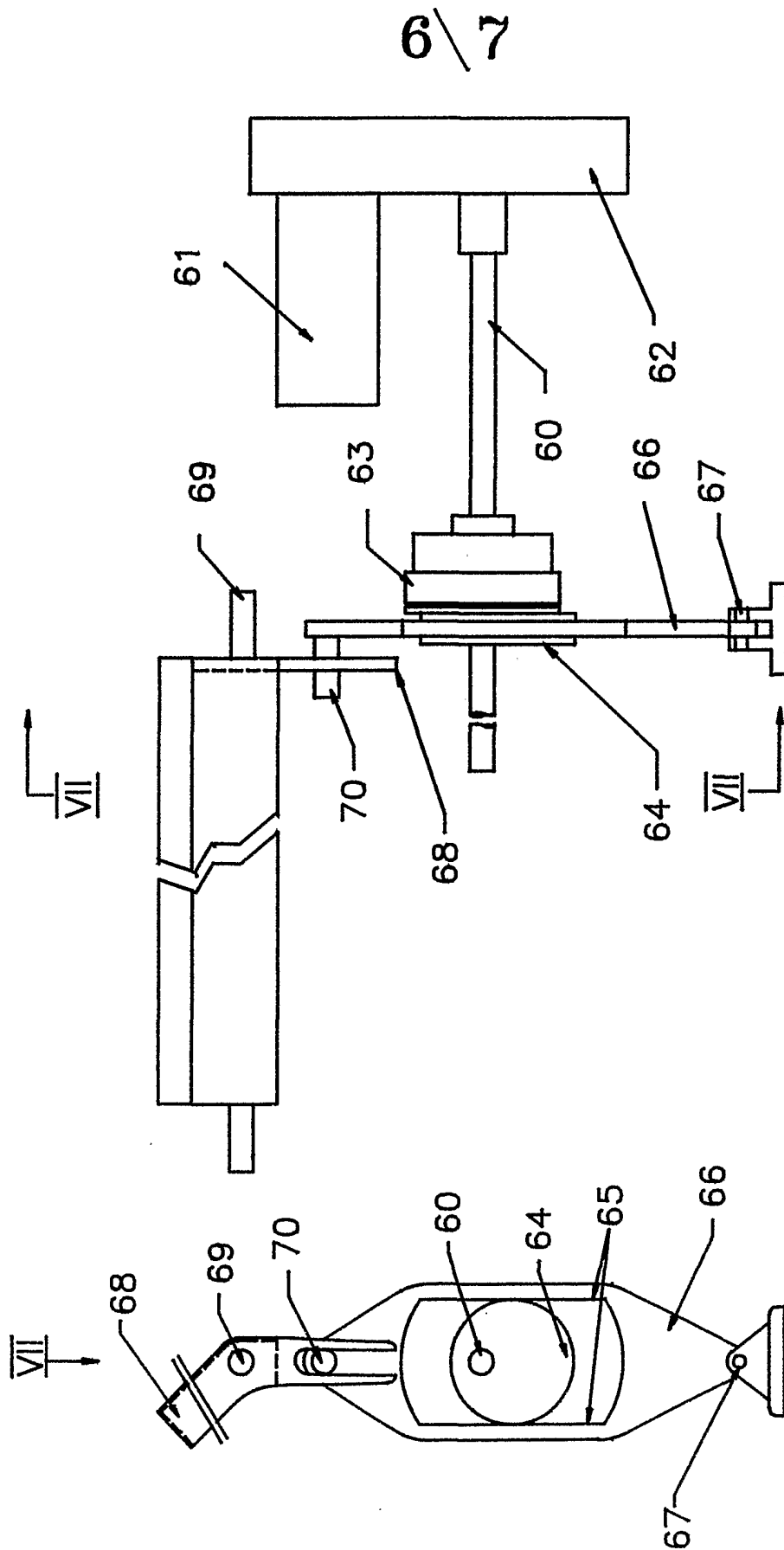

FIG. 6

FIG. 7

7/7

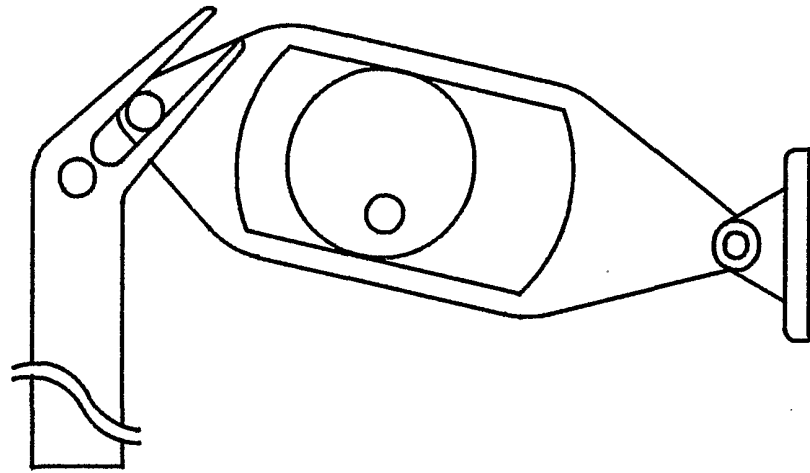

FIG.10

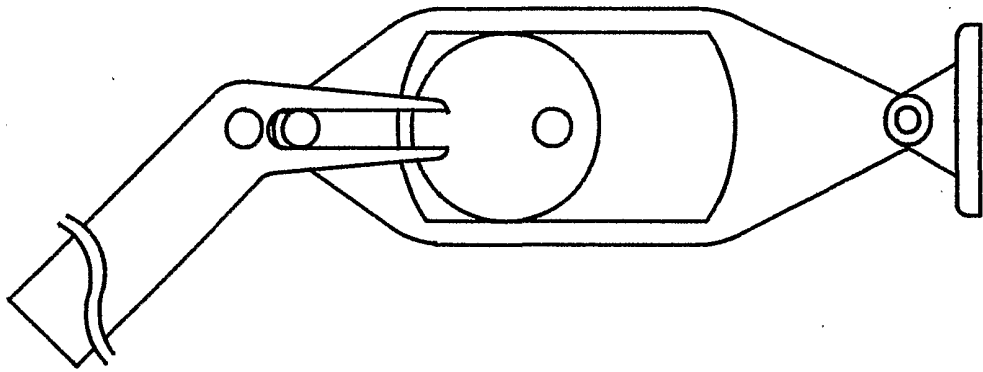

FIG.9

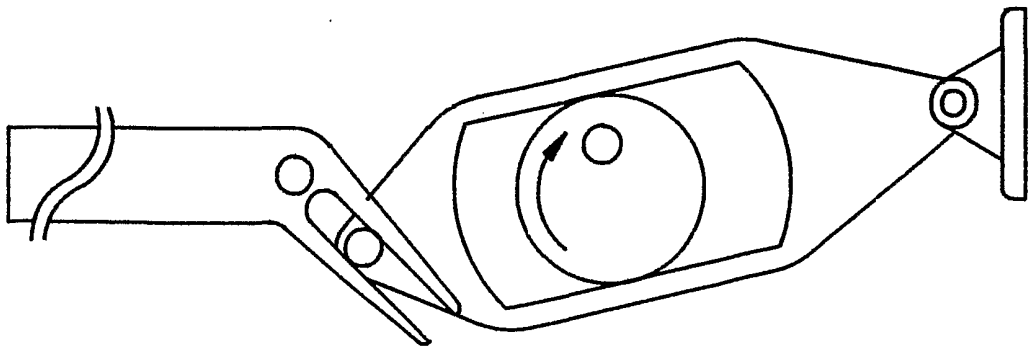

FIG.8

INTERNATIONAL SEARCH REPORT

International Application No
PCT/GB 02/01018

A. CLASSIFICATION OF SUBJECT MATTER
IPC 7 E05F15/20 B65F1/16 A01K5/01 A01K5/02

According to International Patent Classification (IPC) or to both national classification and IPC

B. FIELDS SEARCHED

Minimum documentation searched (classification system followed by classification symbols)
IPC 7 E05F B65F A01K

Documentation searched other than minimum documentation to the extent that such documents are included in the fields searched

Electronic data base consulted during the international search (name of data base and, where practical, search terms used)

EPO-Internal

C. DOCUMENTS CONSIDERED TO BE RELEVANT

Category °	Citation of document, with indication, where appropriate, of the relevant passages	Relevant to claim No.
X A	US 5 932 982 A (PEZZELLI JR EDWARD) 3 August 1999 (1999-08-03) column 3, line 1 -column 5, line 67; figures ---	1,3-5 2,6-16
X A	WO 98 16446 A (STUDER HANS JOERG ;CWS AG (CH)) 23 April 1998 (1998-04-23) page 7, line 17 - line 28 page 8, line 22 - line 30 figures ---	1,2,12 3-11, 13-16
X	US 4 996 467 A (DAY JONG-YIH) 26 February 1991 (1991-02-26) column 1, line 58 -column 2, line 49; figures --- -/--	1,4

Further documents are listed in the continuation of box C.

Patent family members are listed in annex.

° Special categories of cited documents :

- *A* document defining the general state of the art which is not considered to be of particular relevance
- *E* earlier document but published on or after the international filing date
- *L* document which may throw doubts on priority claim(s) or which is cited to establish the publication date of another citation or other special reason (as specified)
- *O* document referring to an oral disclosure, use, exhibition or other means
- *P* document published prior to the international filing date but later than the priority date claimed

- *T* later document published after the international filing date or priority date and not in conflict with the application but cited to understand the principle or theory underlying the invention
- *X* document of particular relevance; the claimed invention cannot be considered novel or cannot be considered to involve an inventive step when the document is taken alone
- *Y* document of particular relevance; the claimed invention cannot be considered to involve an inventive step when the document is combined with one or more other such documents, such combination being obvious to a person skilled in the art.
- *Z* document member of the same patent family

Date of the actual completion of the international search

19 June 2002

Date of mailing of the international search report

28/06/2002

Name and mailing address of the ISA

European Patent Office, P.B. 5818 Patentlaan 2
NL - 2280 HV Rijswijk
Tel. (+31-70) 340-2040, Tx. 31 651 epo nl,
Fax: (+31-70) 340-3016

Authorized officer

Di Renzo, R

INTERNATIONAL SEARCH REPORT

International Application No
PCT/GB 02/01018

C.(Continuation) DOCUMENTS CONSIDERED TO BE RELEVANT		
Category °	Citation of document, with indication, where appropriate, of the relevant passages	Relevant to claim No.
X	US 5 329 212 A (FEIGLESON MICHAEL J) 12 July 1994 (1994-07-12)	1
A	the whole document -----	10,11
A	US 5 669 328 A (LANFRANCHI TAMMY) 23 September 1997 (1997-09-23) cited in the application the whole document -----	1-16
A	US 6 044 795 A (MORI KAZUHIRO ET AL) 4 April 2000 (2000-04-04) cited in the application the whole document -----	1-16

INTERNATIONAL SEARCH REPORT

 International Application No
 PCT/GB 02/01018

Patent document cited in search report		Publication date	Patent family member(s)	Publication date
US 5932982	A	03-08-1999	NONE	
WO 9816446	A	23-04-1998	WO 9816446 A1	23-04-1998
			AT 194960 T	15-08-2000
			AU 7123996 A	11-05-1998
			DE 59605664 D1	31-08-2000
			DK 931005 T3	06-11-2000
			EP 0931005 A1	28-07-1999
			ES 2149497 T3	01-11-2000
			HK 1018607 A1	29-12-2000
			HR 970542 A1	30-06-1998
			HU 9903389 A2	28-02-2000
			JP 2001504073 T	27-03-2001
			NO 991673 A	12-04-1999
			PL 332647 A1	27-09-1999
			PT 931005 T	29-12-2000
			SK 46399 A3	13-03-2000
			US 6211637 B1	03-04-2001
US 4996467	A	26-02-1991	NONE	
US 5329212	A	12-07-1994	NONE	
US 5669328	A	23-09-1997	NONE	
US 6044795	A	04-04-2000	JP 11018608 A	26-01-1999
			CN 1210669 A , B	17-03-1999