

Gothenburg, Sweden, Aug. 20<sup>th</sup>- 24<sup>th</sup>, 2018

---

Agenda Item: 7.1.2.3

Source: Sony

Title: Remaining issues on beam management and beam failure recovery

Document for: Discussion

---

## 1 Introduction

During RAN1 #93 meeting, a few issues on beam management were discussed. However, due to lack of time there are some remaining issues still have to be properly captured in the specifications. In this contribution, we discuss the remaining details of beam management and share our views on the questions in RAN2's incoming LS related to beam failure recovery.

This contribution is a revision of R1-1806563 which was submitted to RAN1 #93 meeting.

## 2 UL beam management

### 2.1 PUCCH

#### Default Tx beam

Between the ambiguous period between RRC re-configuration and subsequent MAC CE activation on *PUCCH-SpatialRelationInfo*, there is need for default spatial relation information for PUCCH. On one hand, a UE may prefer the most recent applicable uplink Tx beam to avoid the phenomenon of beam aging; on the other hand, it is better to keep the specification unity, i.e. treating the 1<sup>st</sup> RRC re-configuration and other RRC re-configurations in a unified way from the standard perspective. Considering both sides, we think the following proposal in [4] is reasonable.

**Proposal 1: Between RRC re-configuration and subsequent MAC CE activation, a UE may refer to the SS/PBCH block resource determined during random access or the most recent spatial relation activated by MAC CE whichever is more recent as the default spatial transmission filter for PUCCH.**

### 2.2 PUSCH

#### Spatial relation indication

In RAN1 #92bis meeting, for the DCI format 0\_0 scheduling PUSCH without SRI, the default spatial relation for PUSCH follows that of PUCCH. To refer, one may find the agreement as below.

**R1-1805574** Feature lead summary 2 on beam measurement and reporting Ericsson

#### **Agreement:**

- For PUSCH scheduled by DCI format 0\_0, the UE shall use a default spatial relation corresponding to the spatial relation, if applicable, used by the PUCCH resource with the lowest ID configured in the active UL BWP
  - Above applies for a cell configured with PUCCH
  - Note: the UE is configured with a list of spatial relations in *PUCCH-SpatialRelationInfo*. MAC-CE indicates a single selected spatial relation from the list on a per-PUCCH resource basis if the list has more than one element.

For PUSCH scheduled by DCI format 0\_1, a UE may be configured with single SRS resource, according to the current specification, there is no SRI filed. Moreover, there might be other case(s) that SRI cannot dynamically indicate spatial relation information for PUSCH. So we believe a similar agreement can be achieved as that for DCI format 0\_0.

**Proposal 2:** For PUSCH scheduled by DCI format 0\_1, if the UE is configured with single SRS resource, then it shall use a default spatial relation corresponding to the spatial relation, if applicable, used by the PUCCH resource with the lowest ID configured in the active UL BWP.

#### **Default Tx beam**

Since the beam indication mechanism of PUSCH in NR builds on the spatial relation of SRS, there is no ambiguous issue between RRC re-configuration and subsequent MAC CE activation/deactivation. But prior to RRC re-configuration, the default spatial relation information of PUSCH is necessary to a UE. During the RAN1 #92bis meeting, we believe the majority seemed to merge to the following proposal.

**Proposal 3:** Prior to UE dedicated configuration, a UE reuses the spatial relation of Msg.3 PUSCH for other PUSCH transmissions.

### **2.3 SRS**

#### **U2/U3 differentiation**

By checking the current version of RRC spec [1], one may find the SRS resource set(s) can be used for the purpose of beam management and each of K SRS resource(s) within the set can be optionally set with *SRS-SpatialRelationInfo* per resource. Therefore, the NW knows the spatial relation of the SRS resource(s) within a SRS resource set prior to SRS Tx. More specifically, if the NW configures the SRS resources with the same spatial Tx filter, then it expects U2 procedure and applies different Rx spatial filter; if the NW configures the SRS resources with different spatial Tx filters, then it expects U3 procedure and applies the same Rx spatial filter. Given the above analysis, we have the following observation.

**Observation 1:** Given current RRC spec, U2/U3 procedure can be implicitly differentiated, therefore there is no need for additional RRC parameter(s) to explicitly distinguish U2/U3 procedure.

## **3 DL beam management**

### **3.1 Beam reporting**

#### **Joint L1-RSRP reporting on SSB and CSI-RS**

For joint L1-RSRP reporting, previously RAN1 had the remaining issue related to the RRC parameter *ReportQuantity*. Given the agreement on supporting joint L1-RSRP reporting based on CSI-RS and QCL-ed SSB, RAN1 needs to decide whether or not to introduce a new parameter in *ReportQuantity*. We notice that during RAN1 #93 meeting, the majority views converged to not adding a new parameter into *ReportQuantity* for joint L1-RSRP reporting.

However, if no new parameter is added in *ReportQuantity*, the behaviour of UE may need further clarification. In the current specification, *ReportQuantity* makes choice between *cri-RSRP* and *ssb-Index-RSRP* without considering independent or joint L1-RSRP reporting. For a UE which only supports independent L1-RSRP reporting, it is clear for this UE to understand the L1-RSRP related configuration. For another UE which optionally supports joint L1-RSRP reporting (UE capability), the UE may interpret *cri-RSRP* or *ssb-Index-RSRP* as independent L1-RSRP reporting or as joint L1-RSRP reporting based on QCL-ed CSI-RS (SSB) and SSB (CSI-RS).

From gNB's perspective, it does not know which RS(s) the L1-RSRP calculated is based on, even if gNB configures the parameter *cri-RSRP/ssb-Index-RSRP* to UE. From our understanding, it matters whether it is beneficial for gNB to know which RS(s) are used for L1-RSRP calculation. If so, then a reasonable choice could be to make the joint L1-RSRP reporting mandatory for UEs which support the feature of joint reporting. Given the reported UE capability and RRC configuration (*cri-RSRP/ssb-Index-RSRP*), gNB is able to infer the RS(s) used for L1-RSRP reporting. However, so far we have not noticed any evidence to support the benefits of gNB knowing which RS(s) the L1-RSRP calculation is based on. Therefore, we propose as follows

**Proposal 4:** For UEs supporting independent and joint L1-RSRP reporting, it is up to UE to report either independent or joint L1-RSRP to gNB, therefore it should not be a mandatory feature.

One potential issue relates to RRC parameter *CSI-ResourceConfig* for CSI-RS resource setting. By checking RRC specification [1], one may notice that SSB resources and CSI-RS resource sets are configured under one CSI-RS resource setting. From the joint L1-RSRP perspective, it would be more convenient to configure SSB resource(s) and CSI-RS resource(s) under one CSI-RS resource set.

**Observation 2: From the perspective of joint L1-RSRP calculation, the SS/PBCH resource(s) and CSI-RS resource(s) should be configured under one CSI-RS resource set.**

## 3.2 Beam indication

### CORESET #0 with TCI state(s)

During RAN1 #92bis meeting, it was agreed that unicast PDSCH can be scheduled by PDCCH located in CORESET #0 in the following agreement.

#### Agreements:

- NW and UE maintain the same understanding on SSB/CORESET#0/SS#0 in connected\_mode at least for non-broadcast PDCCH
  - Solutions FFS
- For the broadcast PDCCH, it is up to UE which common search space to monitor based on which SSB in both connected, in-active, and idle modes

In current specification, each component carrier contains up to 4 BWPs, and each BWP contains up to 3 CORESETs. There is totally up to 12 CORESETs ranging from ID 0 to ID 11 within a carrier, and only one CORESET #0 a UE can be configured with for initial access procedure. But considering only one DL BWP being in active state, CORESET #0 at least is a third of CORESETs for scheduling PDSCH.

To capture the above agreement in the specification, the TCI state(s) *tcI-StatesPDCCH* should be UE-specifically configured for CORESET #0 and one out of the configured TCI states should be activated subsequently. From the perspective of QCL indication, CORESET #0 can be treated as the same as other CORESETs when this UE has entered properly in RRC\_CONNECTED mode.

**Proposal 5: TCI state(s) can be UE-specifically configured and activated subsequently for CORESET #0.**

### Default TCI state(s) for PDCCH

For PDCCH reception, the period between RRC re-configuration and subsequent MAC CE activation is ambiguous to UE. Thanks to the clarification in [4], we also notice that the TCI states of PDCCH are actually configured in RRC re-configuration after RRC configuration is complete. Therefore, it is not necessary to discuss the TCI state(s) of PDCCH associated with RRC configuration. In Figure 1, one may notice the period T1 in which the ACK of PDSCH carrying the initial RRC re-configuration of TCI states has been sent from a UE, but the ACK of PDSCH carrying the subsequent MAC CE which activates TCI state has not been sent from the UE. During T1, the UE doesn't know which configured TCI state is activated for PDCCH. Similarly, one may notice the period T2 which can be considered as the ambiguous period between subsequent RRC re-configuration and MAC CE activation on TCI state(s). The difference between T1 and T2 lies in the fact that the Rx beam determined during initial access procedure may work during T1 as a default Rx beam, but may not work during T2 (after subsequent RRC reconfiguration) due to time-variant fading channel.

As many companies pointed out, at least one default TCI state of PDCCH is necessary for UE to go through the ambiguous periods. Three alternatives can be listed as follows.

- *Alt.1: The DL RS in the lowest entry of TCI-StatesPDCCH is used for the PDCCH beam until the MAC CE activation message is delivered.*
- *Alt.2: The most recent DL RS activated by MAC CE in any of existing CORESETs is used for the PDCCH beam until the MAC CE activation message is delivered.*
- *Alt.3: The SSB determined during initial access procedure is used for the PDCCH beam until the MAC CE activation messages is delivered*

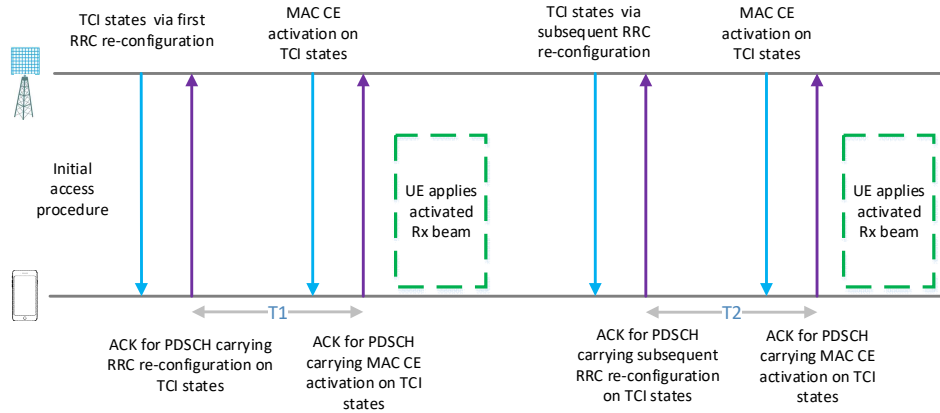

**Figure 1 Ambiguous period between RRC configuration and MAC CE activation**

For the ambiguous period (T1) starting from first RRC re-configuration, it makes sense for a UE to reuse the Rx beam of SSB to receive PDCCH; if the lowest entry of *TCI-StatesPDCCH* is configured as SSB determined during initial access, then Alt.1 is equivalent to Alt.3. In addition, Alt.2 does not exist since there is no most recent DL RS activated by MAC CE right after initial RRC configuration. For the ambiguous period (T2) starting from subsequent RRC re-configuration, it is natural to use the most recent DL RS activated by MAC CE, since the Rx beam determined during initial access may be out-of-date. Finally to capture the default TCI state for PDCCH in the specification, we have a unified proposal similar as [4].

**Proposal 6: Between RRC re-configuration and subsequent MAC CE activation, a UE refers to the SS/PBCH resource determined during random access or the most recent DL RS activated by MAC CE in existing CORESETs whichever is more recent for the default TCI state of PDCCH.**

#### **Default TCI state(s) for PDSCH**

When the scheduling delay is smaller than the pre-defined threshold *Threshold-Sched-Offset*, a UE ignores the indicated TCI state and refers to RS with the lowest CORESET ID in the latest slot when one or more CORESET(s) are configured to this UE. In RAN1 #92bis meeting, the lowest CORESET ID is further clarified to be located in an active BWP. In addition, regarding the latest slot, if there is no slot information configured in the parameter *ControlResourceSet*, a UE may check another related parameter, i.e. *SearchSpace* in which it may find the slot periodicity and offset setting. Considering the parameter *controlResourceSetId* in *SearchSpace*, then the UE may infer the lowest CORESET ID within an active BWP in the latest slot configured for monitoring. Therefore, we think the current specification is fine on default TCI state(s) for PDSCH when the scheduling delay is smaller than *Threshold-Sched-Offset*.

**Observation 3: In current spec, a UE may infer the lowest CORESET ID within active BWP in the latest slot from configured *SearchSpaces* which link the slot periodicity and offset to CORESET ID.**

Since NR supports the feature of carrier aggregation, there might be the chance of cross-carrier scheduling. Specifically, for one UE the CORESET(s) is configured in Carrier 1 and its scheduled PDSCH is located in Carrier 2. Take an extreme case in which Carrier 1 is in FR1 and Carrier 2 is in FR2. Then when the scheduling delay is smaller than the *Threshold-Sched-Offset*, a UE should apply its default Rx beam for PDSCH in Carrier 2 by referring to the lowest CORESET ID of the latest slot in Carrier 1. But due to significant frequency selectivity in some scenarios, a UE needs to apply totally different Rx spatial filters crossing two carriers. Thereby, we believe this is an issue RAN1 should take care of.

**Observation 4: For cross-carrier scheduling, when the scheduling delay is smaller than *Threshold-Sched-Offset*, the lowest CORESET ID of the latest slot in another carrier may not be a proper default TCI state for a UE to receive PDSCH.**

#### **Default TCI state(s) for AP-CSI-RS**

Regarding the time offset issue of aperiodic CSI-RS, if the time gap between DCI carrying the trigger of aperiodic CSI-RS and the CSI-RS transmission is greater than the threshold *Threshold-Sched-Offset*, a UE may have enough time to prepare and apply the indicated Rx spatial filter. Otherwise, this UE has to ignore the indicated TCI states and apply a default TCI state. From our understanding, a simple solution is that in that slot a UE should assume aperiodic CSI-RS QCL-ed in Type D with DMRS of PDSCH.

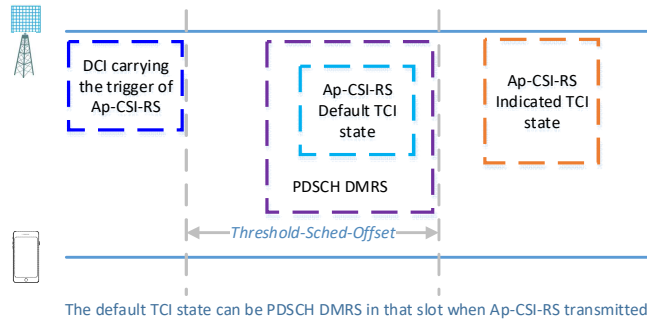

**Figure 2** The time offset between DCI triggering AP-CSI-RS and AP-CSI-RS transmission

**Proposal 7:** The default TCI state for a UE to receive aperiodic CSI-RS is the DMRS of PDSCH in the same slot when the triggered aperiodic CSI-RS is transmitted.

#### 4 Beam failure recovery

Regarding the LS [5] after RAN2’s ad hoc meeting in July, we would like to share our view on the two questions listed below.

**Question 1:** After UE sending PRACH for contention-free BFR, does the UE continue monitoring PDCCH candidates in configured search spaces monitored before PRACH, in addition to the search space indicated by *recoverySearchSpaceId*?

Technically, on one hand the Tx beam of PDCCH is per CORESET configured in RRC and activated in MAC CE, therefore different CORESETs may have different Tx beams. Due to UE rotating, blocking etc, the Tx-Rx beam pair of one CORESET may suffer from low quality, but the quality of other CORESETs may still be good. In addition, different services can be scheduled by using different CORESETs. Being active on old search space(s), UE’s PDSCH reception may not be influenced by current failed Tx-Rx beam pair, which means the UE could behave like monitoring paging, continuing the uncompleted transmission (HARQ) on other Tx-Rx beam pairs.

On the other hand, the gNB may choose not to schedule a UE involved in a BFR procedure and if a UE continues to monitor other search space(s), it would bring additional computation complexity at UE side and burn UE’s battery unnecessarily. Given the discussion above, we have following proposal

**Proposal 8:** It is up to UE’s implementation whether the UE continues to monitor PDCCH candidates in other search space(s) in addition to the search space with *recoverySearchSpaceId*, after UE sends PRACH for contention-free BFR.

**Question 2:** If the answer to Question 1 is “Yes”, is the BFR RACH procedure considered successfully completed only if PDCCH is received in search space indicated by *recoverySearchSpaceId*?

From our view, if the UE successfully detects a PDCCH scheduling PDSCH in any other search space(s) rather than the search space with *recoverySearchSpaceId*, it should not mean the completion of BFR. Specifically, if the UE successfully detects a PDCCH in the original search space which is considered as in BFR by the UE, the UE cannot fully guarantee the beam failure event has been recovered by itself. The fact is clear that the UE triggers BFR of original search space with BLER higher than a pre-defined threshold, e.g. 10%, but in this case the UE still has 90% probability to successfully decode a PDCCH in the original search space. So we would like to say

**Proposal 9:** The BFR RACH procedure can only be considered as successfully completed when the UE detects PDCCH in the search space with *recoverySearchSpaceId*.

#### 5 Conclusions

Finally, allow us to repeat our proposals for two items separately.

## Beam management

**Proposal 1:** For PUSCH scheduled by DCI format 0\_1, if the UE is configured with single SRS resource, then it shall use a default spatial relation corresponding to the spatial relation, if applicable, used by the PUCCH resource with the lowest ID configured in the active UL BWP.

**Proposal 2:** Proposal 1: Between RRC re-configuration and subsequent MAC CE activation, a UE may refer to the SS/PBCH block resource determined during random access or the most recent spatial relation activated by MAC CE whichever is more recent as the default spatial transmission filter for PUCCH.

**Proposal 3:** Prior to UE dedicated configuration, a UE reuses the spatial relation of Msg.3 PUSCH for other PUSCH transmissions.

**Proposal 4:** For UEs supporting independent and joint L1-RSRP reporting, it is up to UE to report either independent or joint L1-RSRP to gNB, therefore it should not be a mandatory feature.

**Proposal 5:** TCI state(s) can be UE-specifically configured and activated subsequently for CORESET #0.

**Proposal 6:** Between RRC re-configuration and subsequent MAC CE activation, a UE refers to the SS/PBCH resource determined during random access or the most recent DL RS activated by MAC CE in existing CORESETs whichever is more recent for the default TCI state of PDCCH.

**Proposal 7:** The default TCI state for a UE to receive aperiodic CSI-RS is the DMRS of PDSCH in the same slot when the triggered aperiodic CSI-RS is transmitted.

## Beam failure recovery

**Proposal 8:** It is up to UE's implementation whether the UE continues to monitor PDCCH candidates in other search space(s) in addition to the search space with *recoverySearchSpaceId*, after UE sends PRACH for contention-free BFR.

**Proposal 9:** The BFR RACH procedure can only be considered as successfully completed when the UE detects PDCCH in the search space with *recoverySearchSpaceId*.

## 6 References

- [1] 3GPP TS 38.331, Radio Resource Control (RRC) protocol specification.
- [2] 3GPP TS 38.321, Medium Access Control (MAC) protocol specification.
- [3] R1-1805627 LS on UL cross carrier beam indication.
- [4] R1-1805574 Feature lead summary 2 on beam management.
- [5] R2-1810807, LS on termination of contention-free BFR.