



(19) **United States**

(12) **Patent Application Publication**  
**SEO et al.**

(10) **Pub. No.: US 2021/0050936 A1**

(43) **Pub. Date: Feb. 18, 2021**

(54) **METHOD BY WHICH TERMINAL MONITORS CONTROL CHANNEL IN WIRELESS COMMUNICATION SYSTEM, AND TERMINAL USING METHOD**

**Publication Classification**

(51) **Int. Cl.**  
*H04L 1/00* (2006.01)  
*H04L 5/00* (2006.01)  
*H04W 72/12* (2009.01)

(52) **U.S. Cl.**  
 CPC ..... *H04L 1/0038* (2013.01); *H04W 72/1289* (2013.01); *H04L 5/0023* (2013.01)

(71) Applicant: **LG Electronics Inc.**, Seoul (KR)

(72) Inventors: **Inkwon SEO**, Seoul (KR); **Yunjung Yi**, Seoul (KR)

(21) Appl. No.: **16/628,225**

(22) PCT Filed: **May 8, 2019**

(86) PCT No.: **PCT/KR2019/005493**

§ 371 (c)(1),

(2) Date: **Jan. 2, 2020**

**Related U.S. Application Data**

(60) Provisional application No. 62/669,352, filed on May 9, 2018, provisional application No. 62/670,038, filed on May 11, 2018.

(57) **ABSTRACT**

A method by which a terminal monitors a control channel in a wireless communication system, and a device using the method are provided. The method determines whether physical downlink control channel (PDCCH) monitoring occasions overlap in a plurality of control resource sets (CORESETs), selects at least one CORESET from among the plurality of CORESETs when the PDCCH monitoring occasions overlap, and monitors a PDCCH only in the selected at least one CORESET from among the plurality of CORESETs.

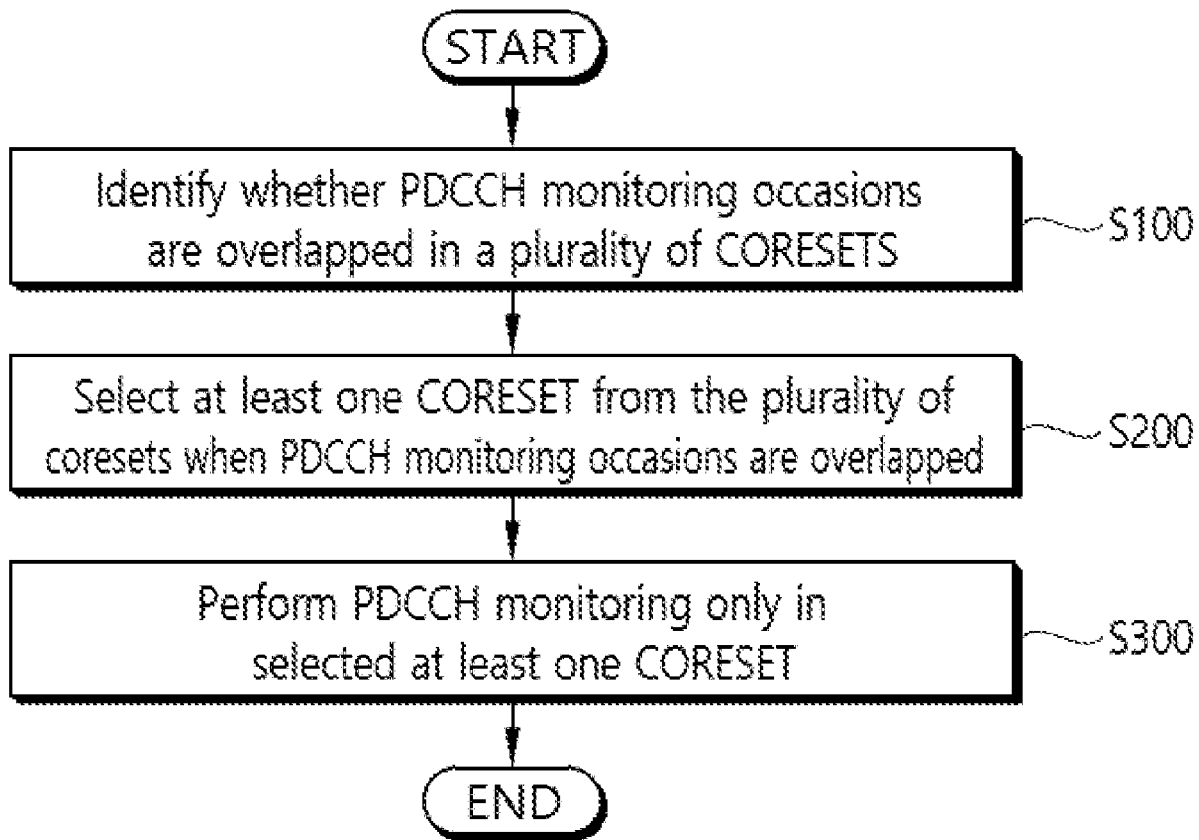

FIG. 1

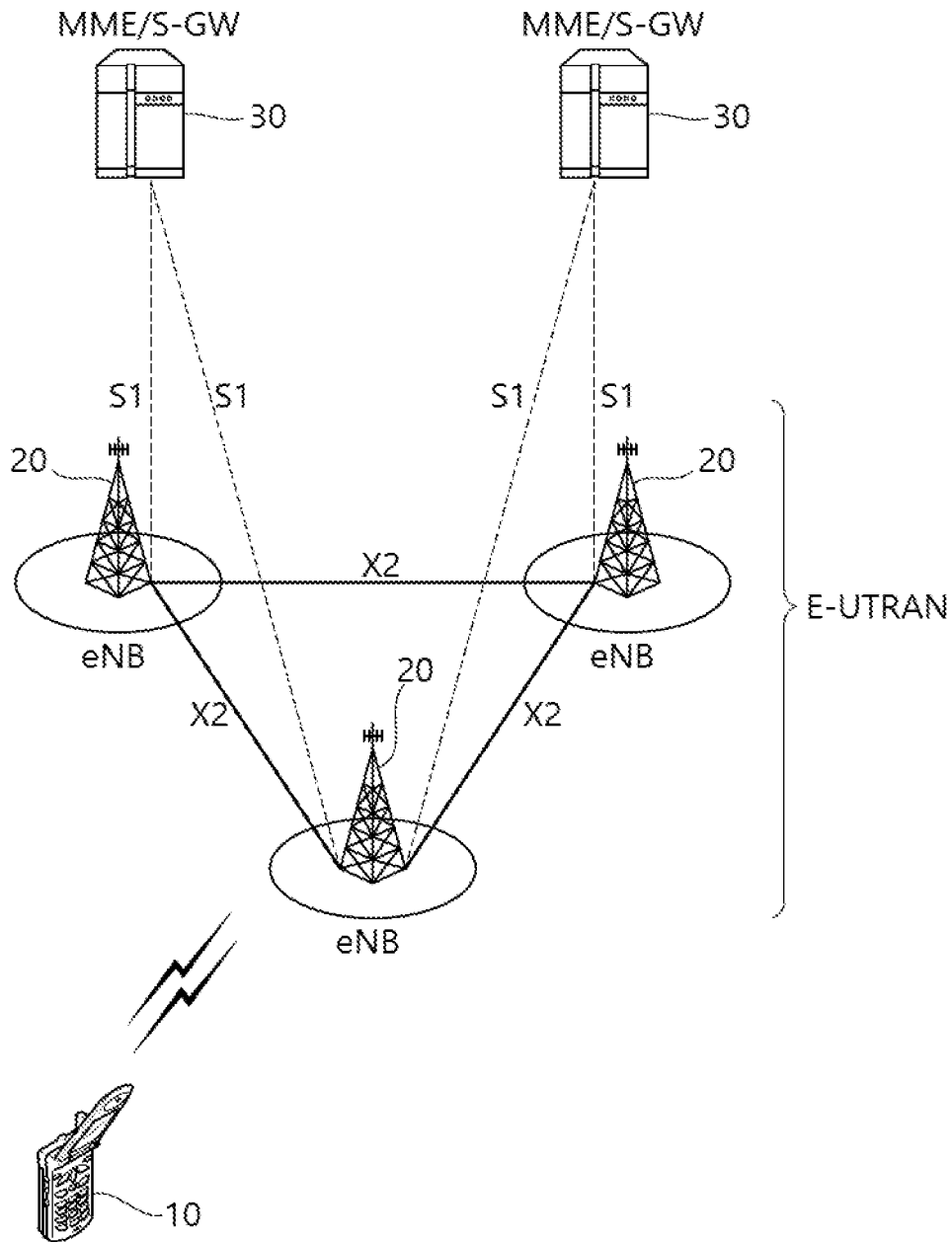

FIG. 2

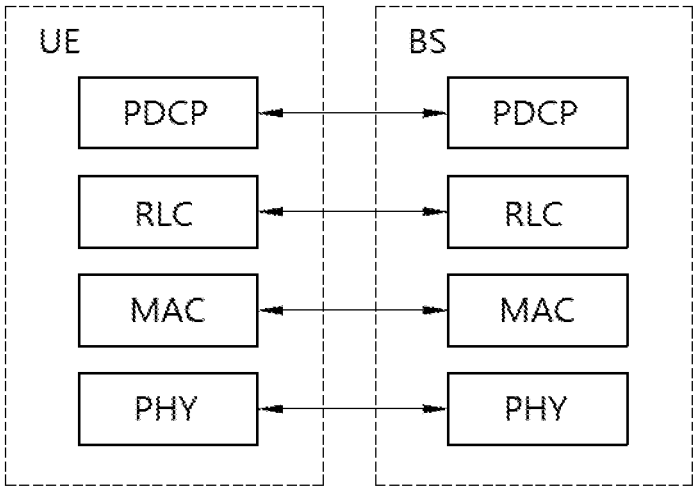

FIG. 3

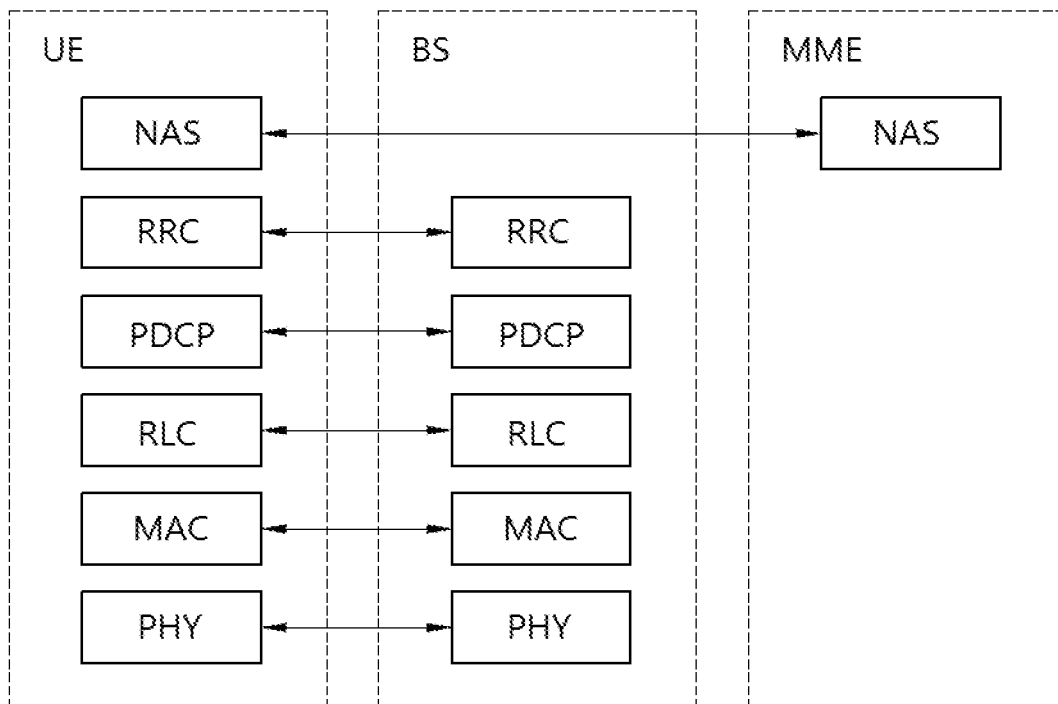

FIG. 4

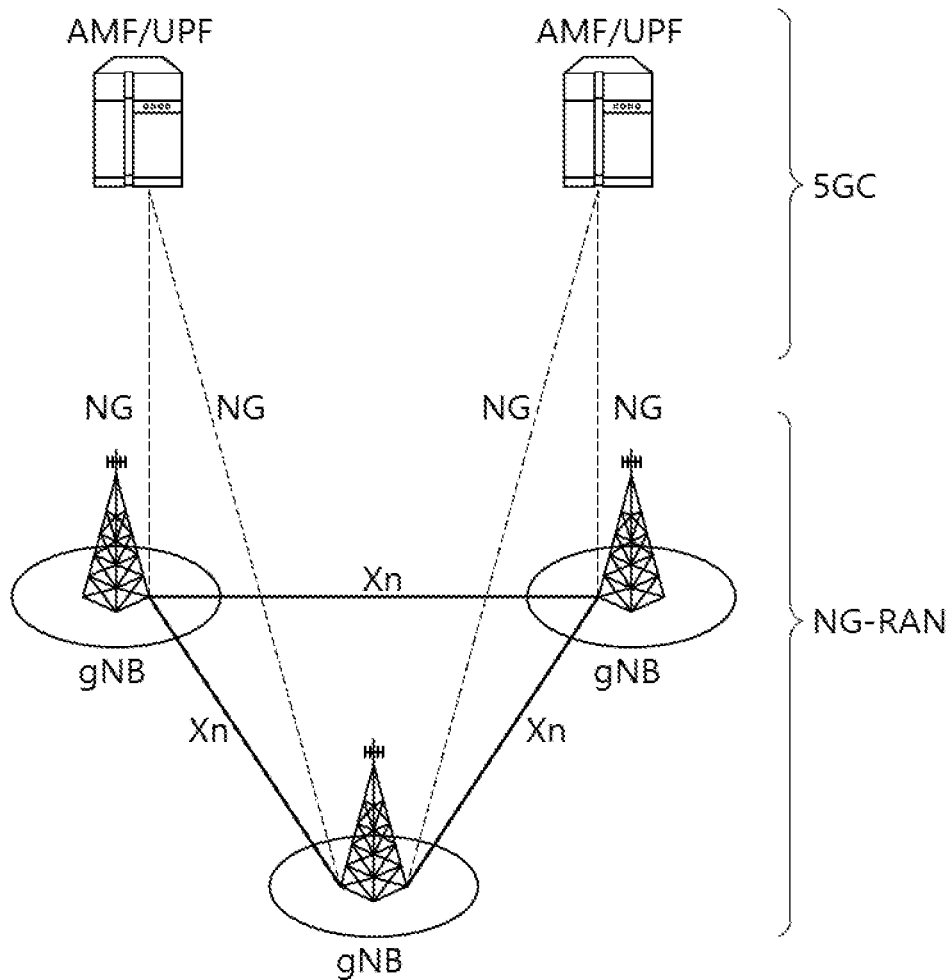

FIG. 5

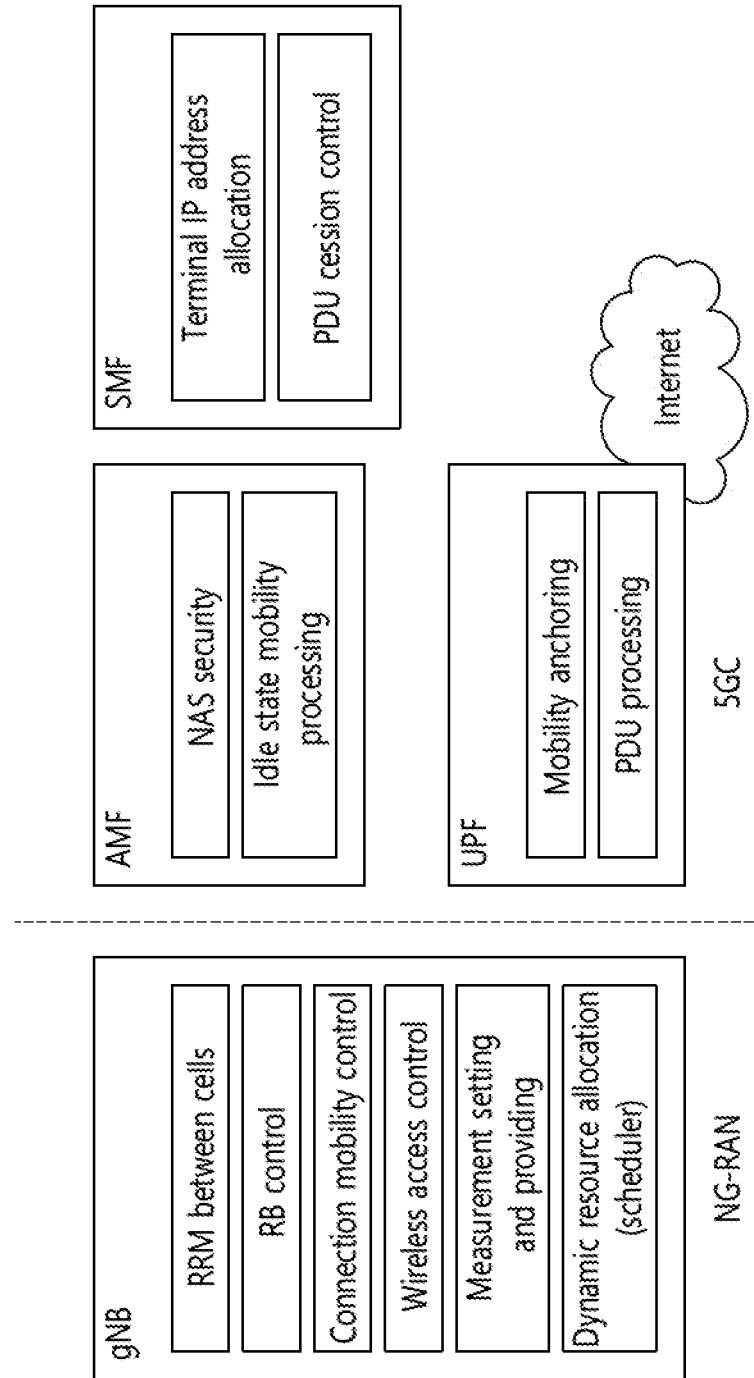

FIG. 6

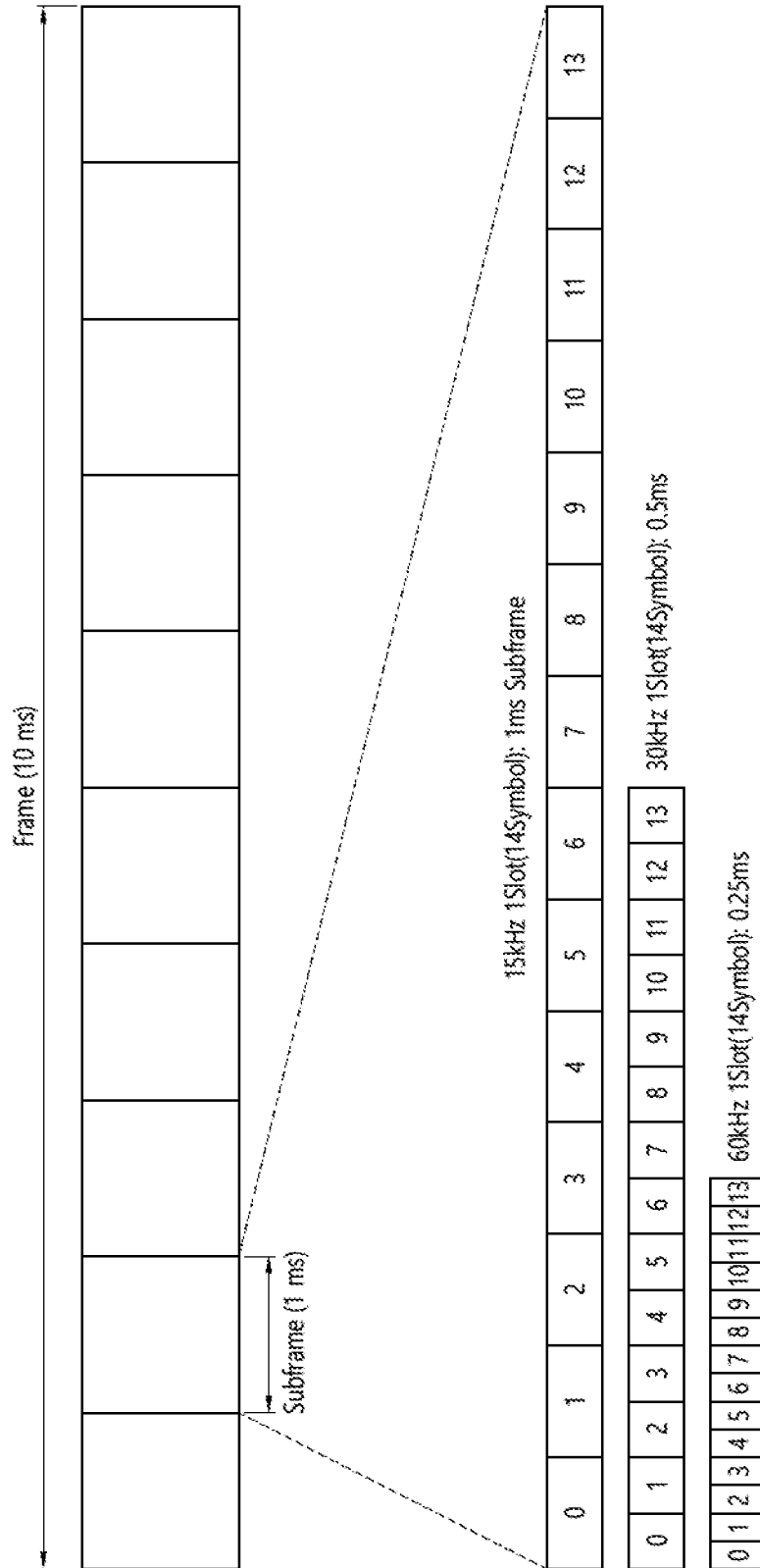

FIG. 7

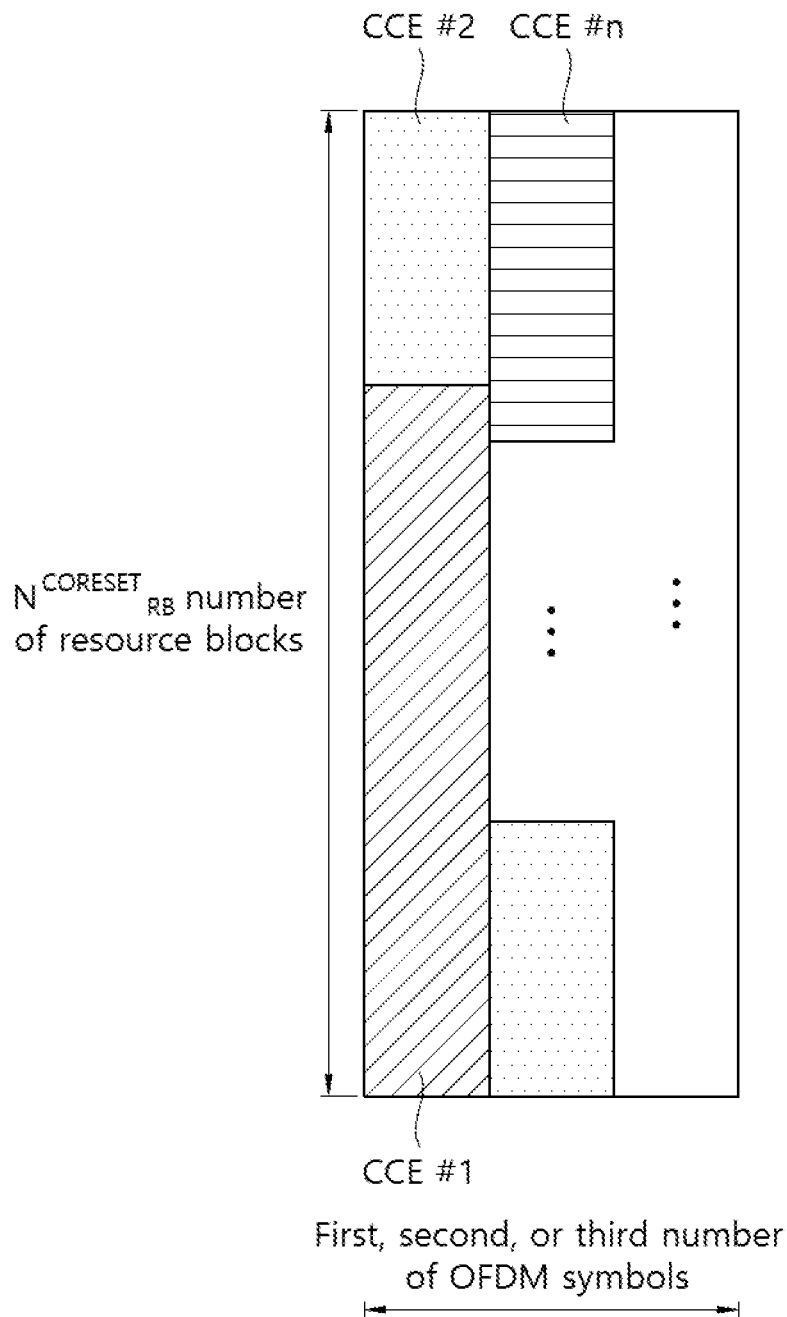

FIG. 8

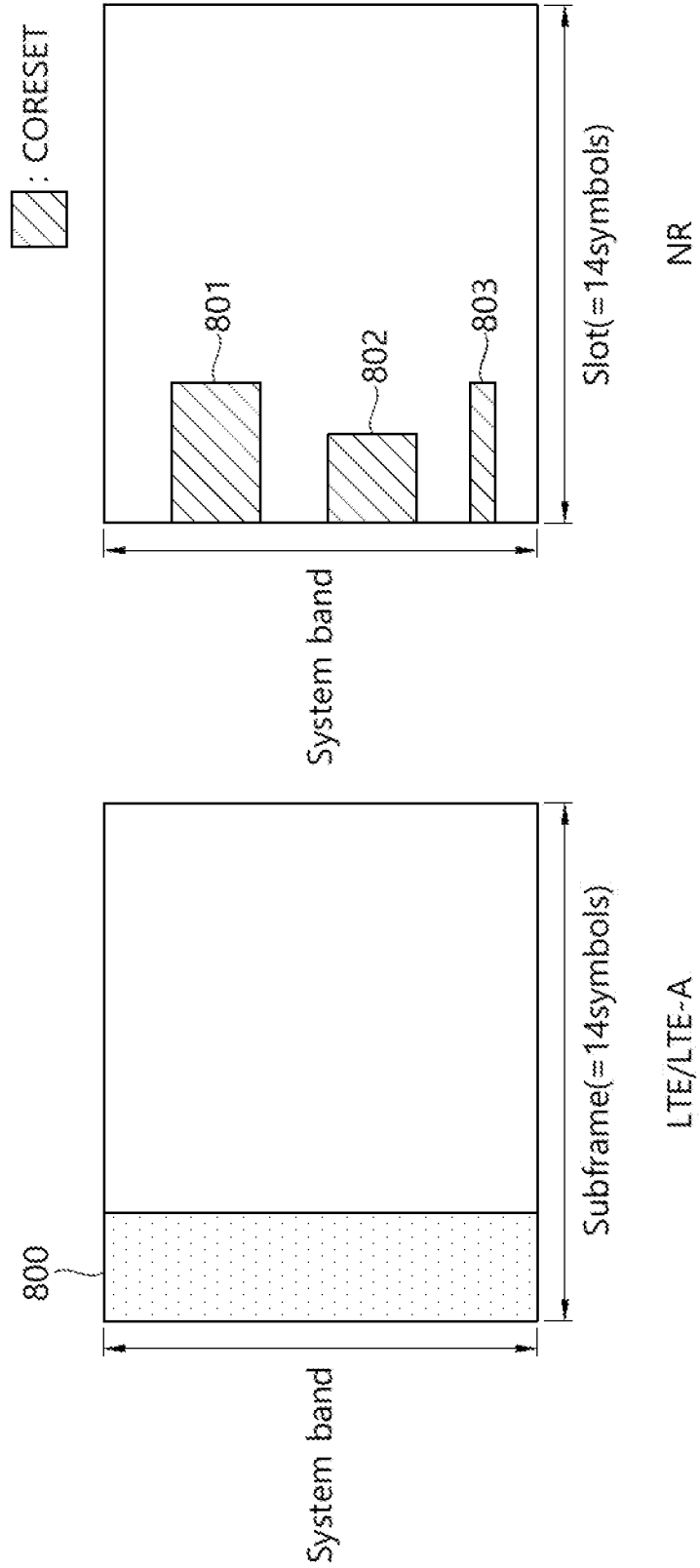

FIG. 9

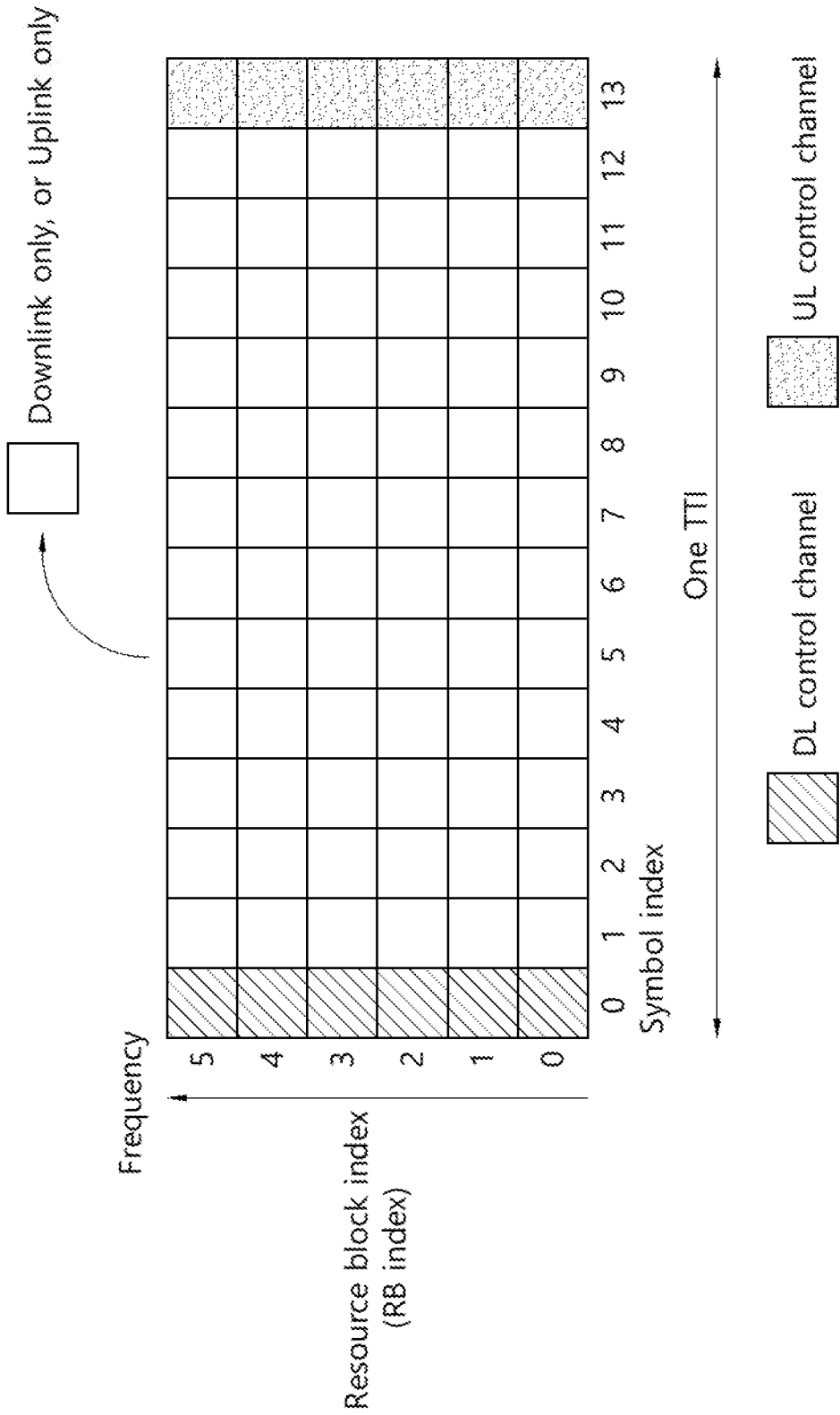

FIG. 10

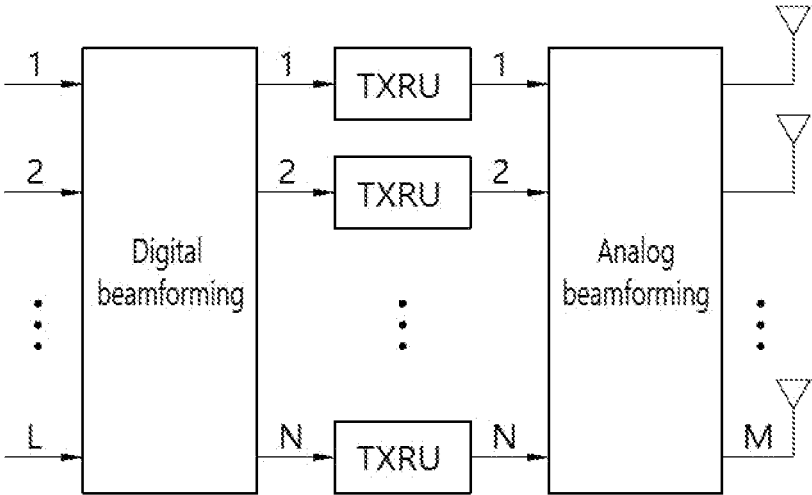

FIG. 11

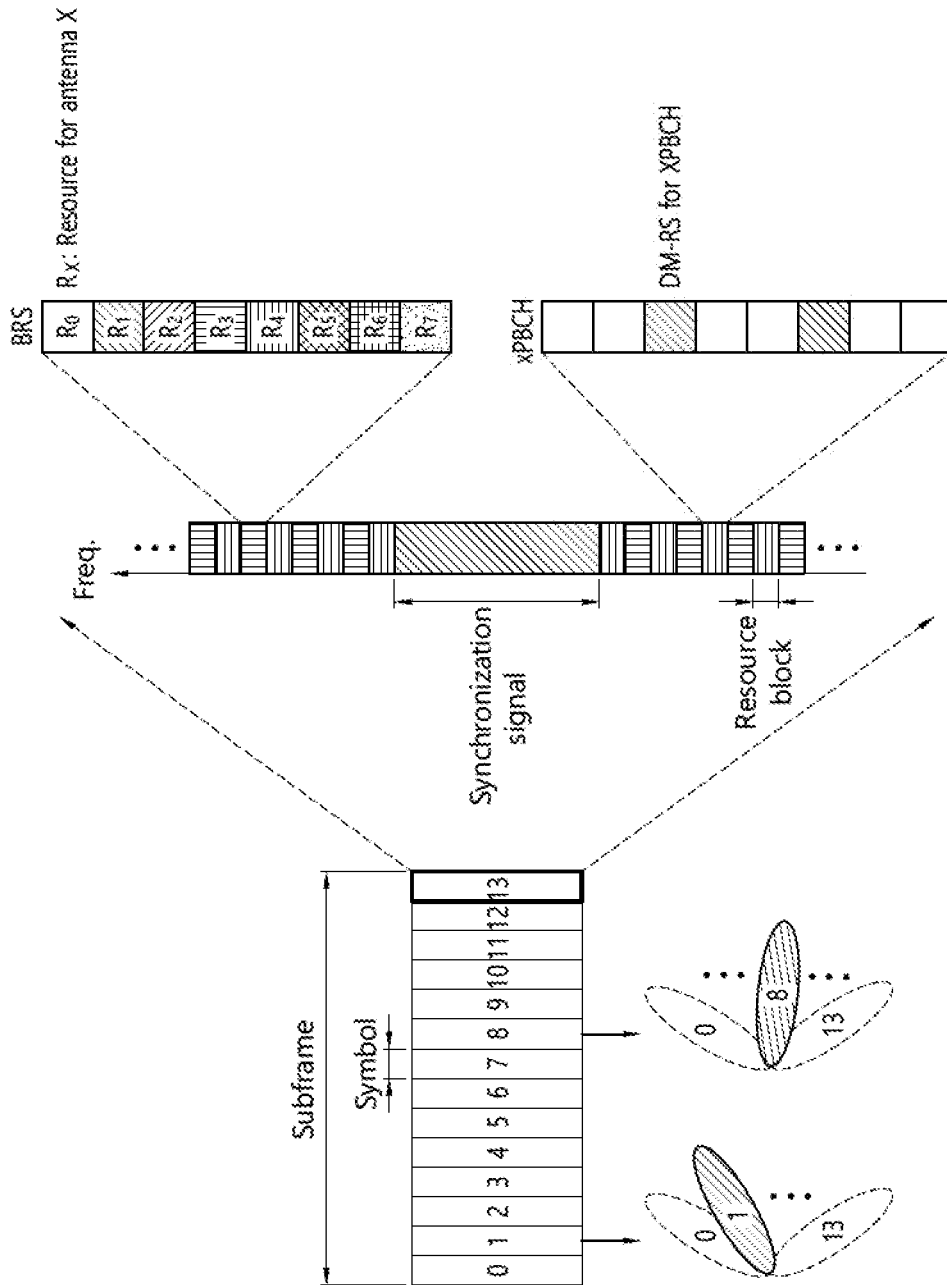

FIG. 12

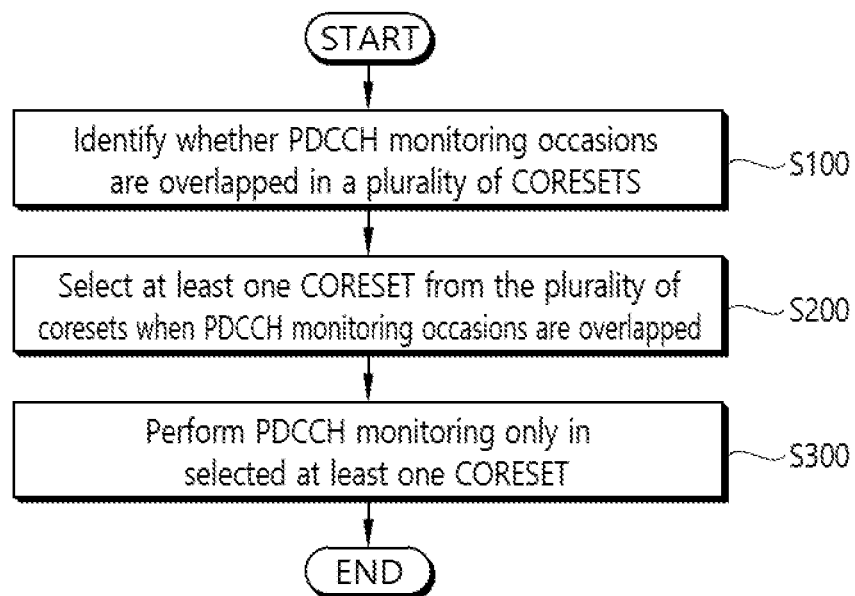
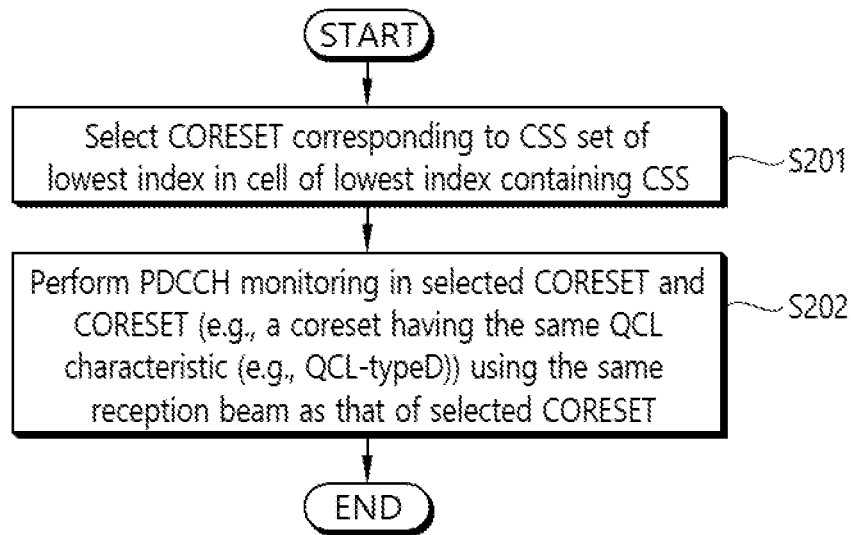
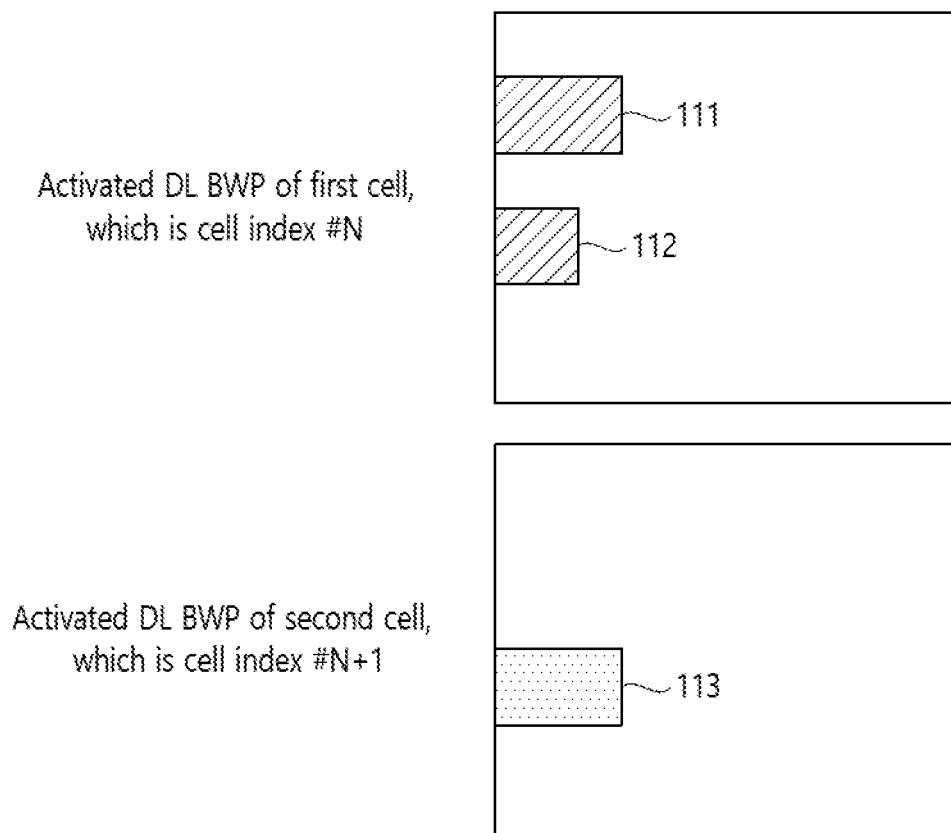



FIG. 13



# FIG. 14



 : CORESET having the same QCL type D characteristic

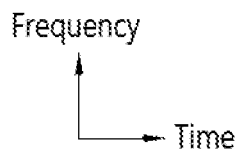

FIG. 15

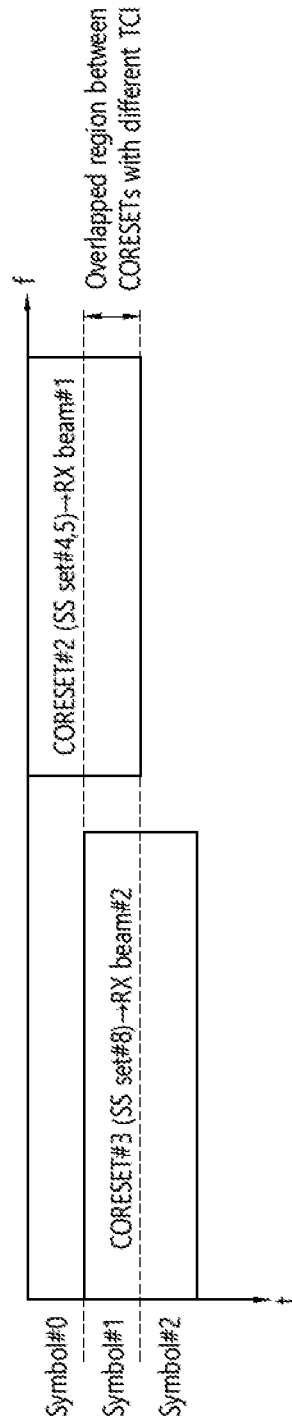

FIG. 16

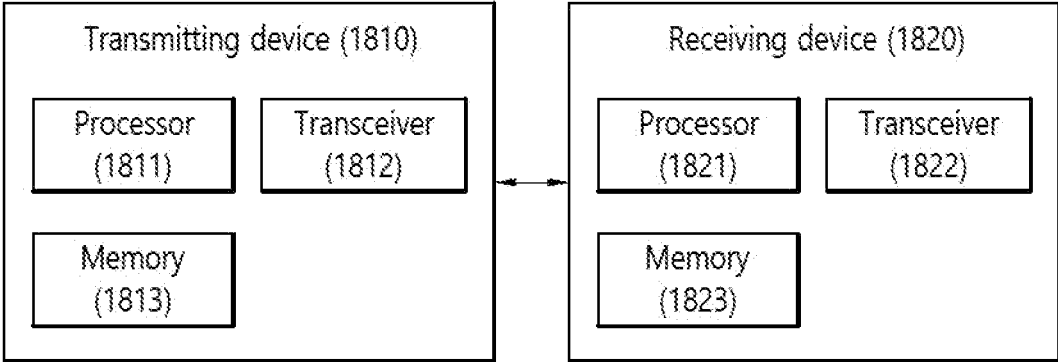

FIG. 17

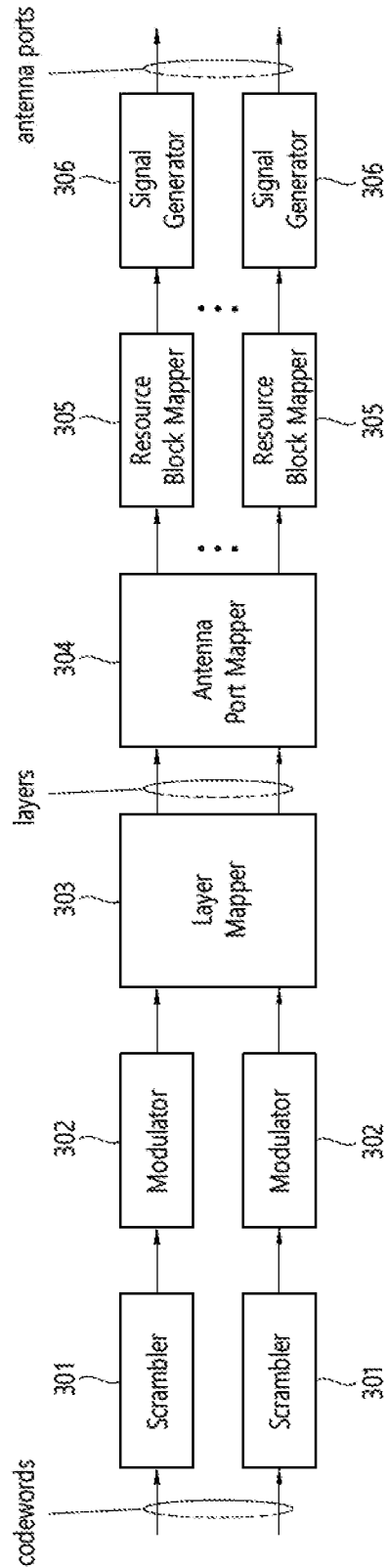

FIG. 18

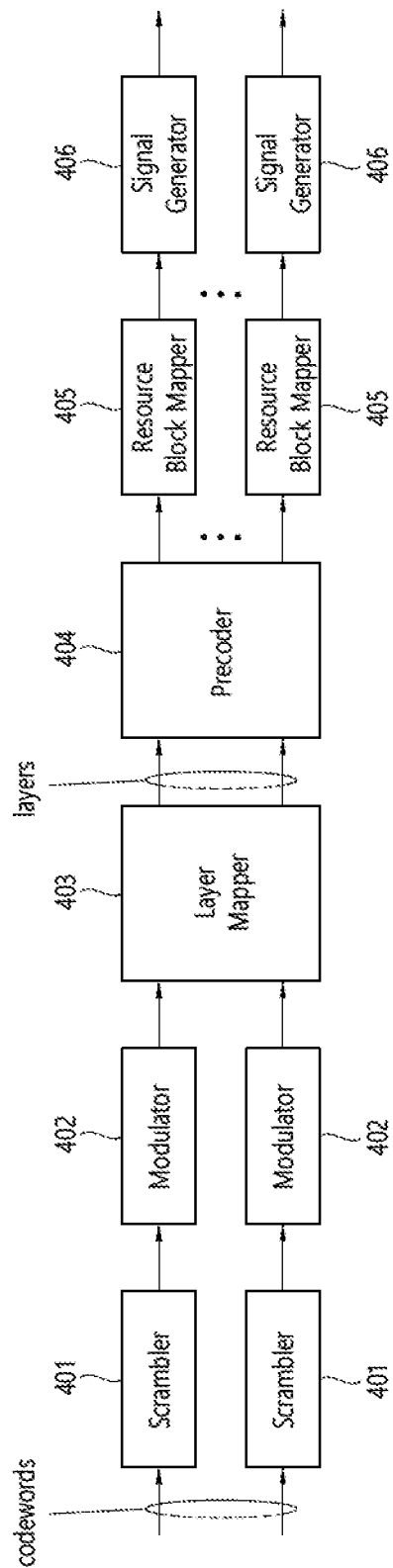

FIG. 19

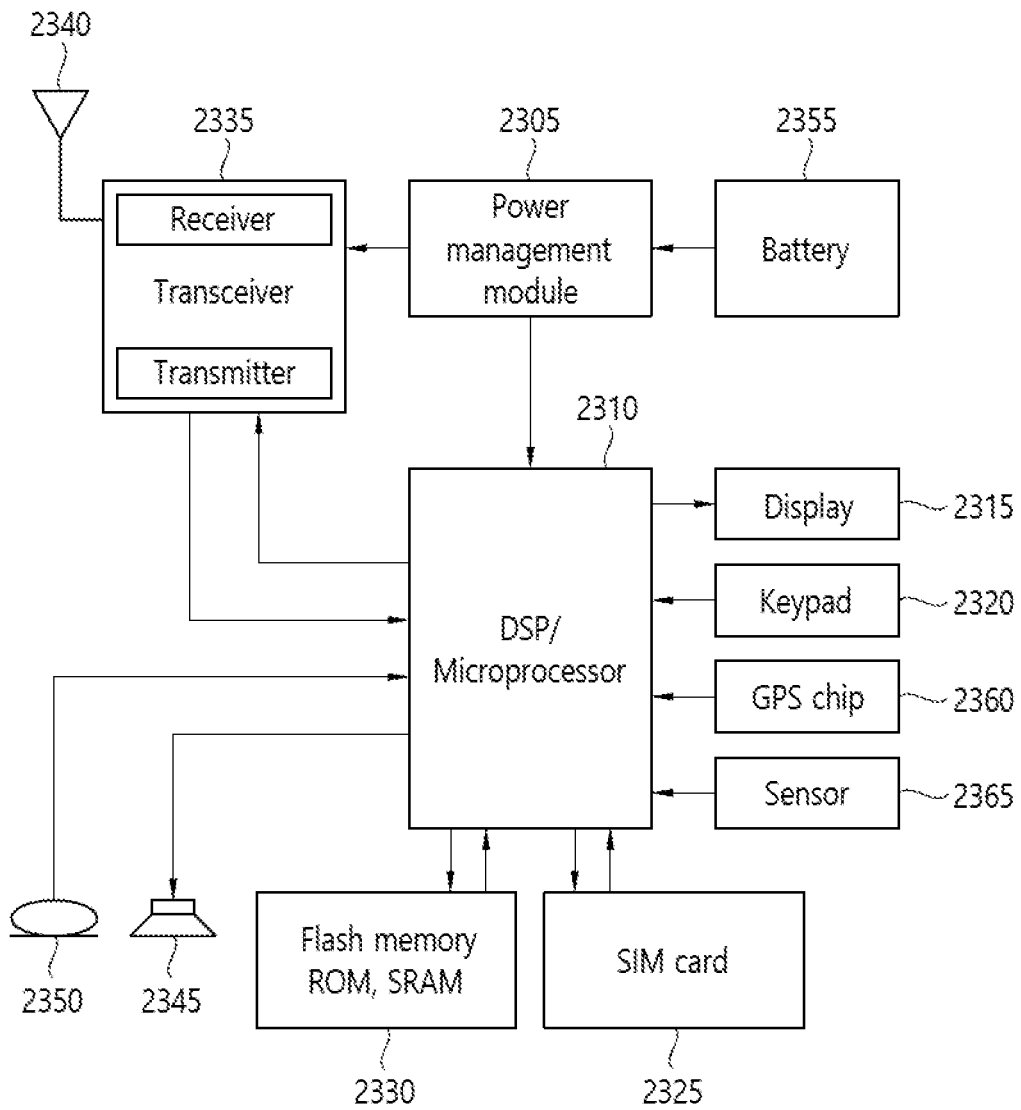

FIG. 20

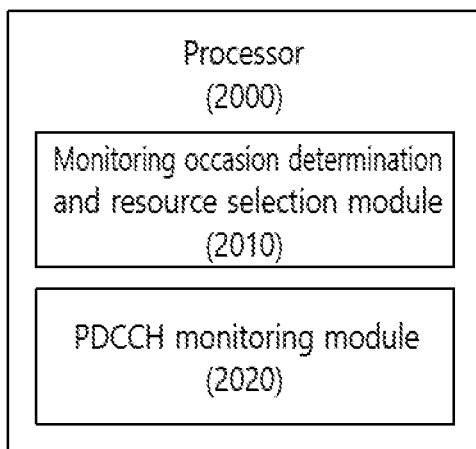

FIG. 21

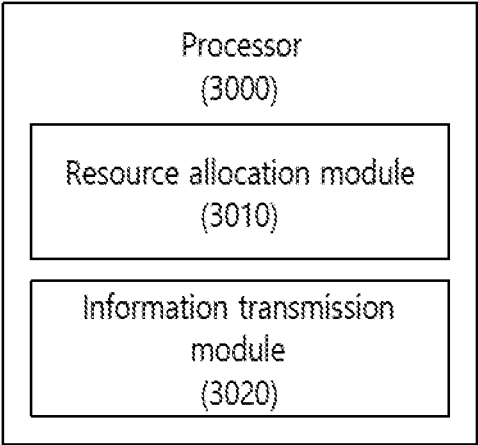

FIG. 22

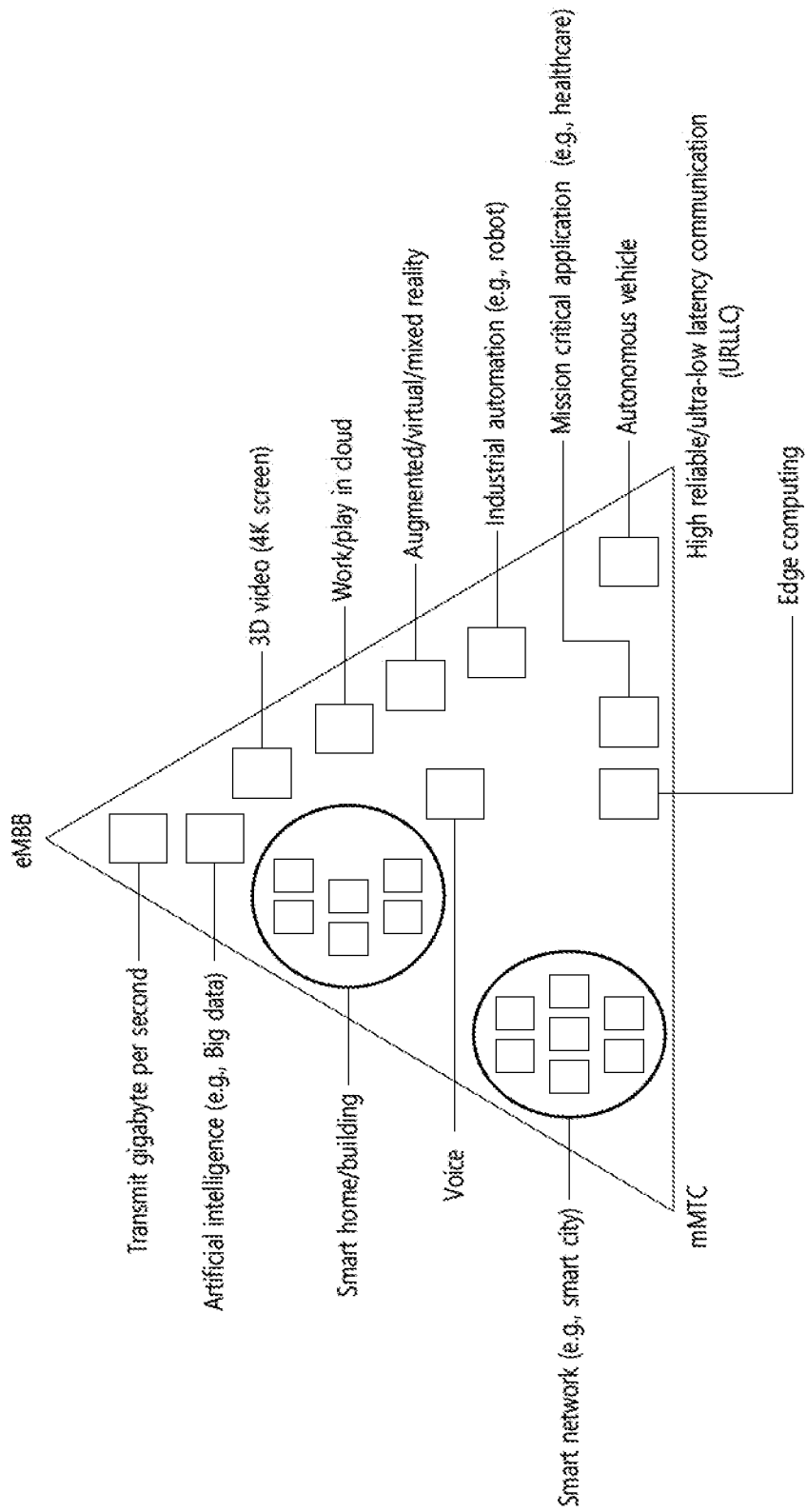
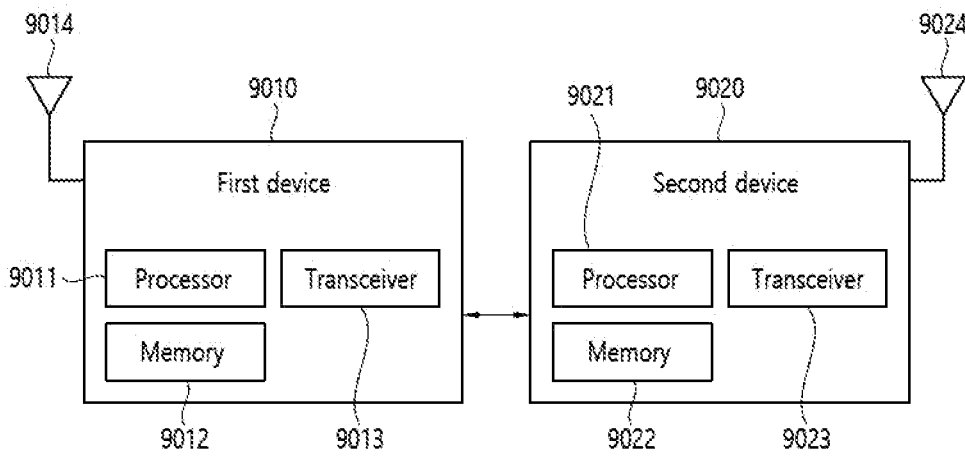

FIG. 23



**METHOD BY WHICH TERMINAL  
MONITORS CONTROL CHANNEL IN  
WIRELESS COMMUNICATION SYSTEM,  
AND TERMINAL USING METHOD**

BACKGROUND OF THE DISCLOSURE

Field of the Disclosure

**[0001]** The present disclosure relates to wireless communication, and more particularly, to a method of monitoring a control channel of a terminal in a wireless communication system and a terminal using the method.

Related Art

**[0002]** As more and more communication devices require more communication capacity, there is a need for improved mobile broadband communication over existing radio access technology. Also, massive machine type communications (MTC), which provides various services by connecting many devices and objects, is one of the major issues to be considered in the next generation communication. In addition, communication system design considering reliability/latency sensitive service/UE is being discussed. The introduction of next generation radio access technology considering enhanced mobile broadband communication (eMBB), massive MTC (mMTC), ultra-reliable and low latency communication (URLLC) is discussed. This new technology may be called new radio access technology (new RAT or NR) in the present disclosure for convenience. NR is also called the fifth generation (5G) system.

**[0003]** In NR, a terminal may receive a control signal using a time/frequency resource called a control resource set (CORESET), which is a part of a system band. The terminal may be tuned to one or more CORESETs. However, in some cases, frequency and time resources of one CORESET may be overlapped with frequency and time resources of another CORESET. In this case, there is a problem in a method in which the terminal monitors a control signal.

SUMMARY OF THE DISCLOSURE

**[0004]** The present disclosure provides a method of monitoring a control channel of a terminal in a wireless communication system and a terminal using the method.

**[0005]** In one aspect, provided is a method of monitoring a control channel of a user equipment (UE) in a wireless communication system. The method includes identifying whether physical downlink control channel (PDCCH) monitoring occasions are overlapped in a plurality of control resource sets (CORESETs), selecting at least one CORESET from the plurality of CORESETs based on the PDCCH monitoring occasions being overlapped and monitoring a PDCCH only in the at least one CORESET selected from the plurality of CORESETs.

**[0006]** The at least one CORESET may be selected based on a type of a related search space.

**[0007]** The type of the search space may be a common search space (CSS) or a UE-specific search space (USS).

**[0008]** The selecting of at least one CORESET may include selecting a CORESET comprising a common search space having a lowest index when there are a plurality of CORESETs comprising a common search space (CSS).

**[0009]** The method may further comprise selecting a first CORESET corresponding to a CSS set with a lowest index in a cell with a lowest index containing a CSS among the plurality of CORESETs.

**[0010]** The method may further comprise monitoring a PDCCH in the first CORESET and any other CORESET using a same reception beam as that of the first CORESET.

**[0011]** The any other CORESET using the same reception beam as that of the first CORESET may be a CORESET having a same quasi co location (QCL) characteristics as that of the first CORESET.

**[0012]** In another aspect, provided is a user equipment (UE). The UE includes a transceiver for transmitting and receiving wireless signals and a processor for operating in combination with the transceiver. The processor is configured to: identify whether physical downlink control channel (PDCCH) monitoring occasions are overlapped in a plurality of control resource sets (CORESETs), select at least one CORESET from the plurality of CORESETs based on the PDCCH monitoring occasions being overlapped and monitor a PDCCH only in the at least one CORESET selected from the plurality of CORESETs.

**[0013]** The at least one CORESET may be selected based on a type of a related search space.

**[0014]** The type of the search space may be a common search space (CSS) or a UE-specific search space (USS).

**[0015]** The selecting of at least one CORESET may comprise selecting a CORESET comprising a common search space having a lowest index when there are a plurality of CORESETs comprising a common search space (CSS).

**[0016]** The UE may select a first CORESET corresponding to a CSS set with a lowest index in a cell with a lowest index containing a CSS among the plurality of CORESETs.

**[0017]** The UE may monitor a PDCCH in the first CORESET and any other CORESET using a same reception beam as that of the first CORESET.

**[0018]** The any other CORESET using the same reception beam as that of the first CORESET may be a CORESET having a same quasi co location (QCL) characteristics as that of the first CORESET.

**[0019]** The UE may communicate with at least one of a mobile UE, a network, and an autonomous vehicle other than the UE.

**[0020]** In still another aspect, provided is a processor for controlling a wireless communication device in a wireless communication system. The processor controls the wireless communication device to: identify whether physical downlink control channel (PDCCH) monitoring occasions are overlapped in a plurality of control resource sets (CORESETs), select at least one CORESET from the plurality of CORESETs based on the PDCCH monitoring occasions being overlapped and monitor a PDCCH only in the at least one CORESET selected from the plurality of CORESETs.

**[0021]** According to the present disclosure, when a plurality of CORESETs is overlapped at a monitoring occasion/opportunity of a control signal, a control signal is monitored only in a selected specific CORESET according to a priority. In the conventional communication system, because the UE monitored a control signal (e.g., PDCCH) in an entire system band, there was no case in which a plurality of CORESETs to be monitored exists at a monitoring occasion/opportunity of the control signal. That is, a situation to be dealt by the present disclosure has not existed in the past, and the present disclosure proposes a processing method for

such a situation. Further, according to the present disclosure, unnecessary power consumption of the terminal can be reduced. Further, a network can transmit a control signal through a CORESET in which the terminal may receive a control signal among a plurality of CORESETs in consideration of a priority. That is, according to the present disclosure, because it is unnecessary that the terminal monitors all of a plurality of CORESETs overlapped at a control channel monitoring occasion (opportunity), even in a system in which more CORESETs than the number of CORESETs are allocated in which the terminal may monitor simultaneously, for example, a communication environment beyond a capability of the terminal, the terminal can operate without a problem.

#### BRIEF DESCRIPTION OF THE DRAWINGS

[0022] FIG. 1 shows a wireless communication system to which the present disclosure may be applied.

[0023] FIG. 2 is a diagram showing a wireless protocol architecture for a user plane.

[0024] FIG. 3 is a diagram showing a wireless protocol architecture for a control plane.

[0025] FIG. 4 illustrates a system structure of a next generation radio access network (NG-RAN) to which NR is applied.

[0026] FIG. 5 illustrates a functional division between an NG-RAN and a 5G.

[0027] FIG. 6 illustrates an example of a frame structure that may be applied in NR.

[0028] FIG. 7 illustrates CORESET.

[0029] FIG. 8 is a diagram illustrating a difference between a related art control region and the CORESET in NR.

[0030] FIG. 9 illustrates an example of a frame structure for new radio access technology.

[0031] FIG. 10 is an abstract schematic diagram illustrating hybrid beamforming from the viewpoint of TXRUs and physical antennas.

[0032] FIG. 11 illustrates the beam sweeping operation for a synchronization signal and system information in a downlink (DL) transmission procedure.

[0033] FIG. 12 illustrates a PDCCH monitoring method of a UE according to one embodiment of the present disclosure.

[0034] FIG. 13 illustrates a specific example of selecting a specific CORESET from a plurality of CORESETs when using options 2 and 3.

[0035] FIG. 14 illustrates a PDCCH monitoring method when using the above-described options 2 and 3.

[0036] FIG. 15 illustrates a case where two different CORESETs configured with different TCI states overlap each other in the time domain.

[0037] FIG. 16 is a block diagram showing components of a transmitting device and a receiving device for implementing the present disclosure.

[0038] FIG. 17 illustrates an example of a signal processing module structure in the transmitting device.

[0039] FIG. 18 illustrates another example of the signal processing module structure in the transmitting device.

[0040] FIG. 19 illustrates an example of a wireless communication device according to an implementation example of the present disclosure.

[0041] FIG. 20 illustrates a processor on the side of a terminal.

[0042] FIG. 21 illustrates a processor on the side of a base station.

[0043] FIG. 22 illustrates an example of a 5G use scenario to which technical characteristics of the present disclosure may be applied.

[0044] FIG. 23 illustrates a wireless communication device according to an embodiment of the present disclosure.

#### DESCRIPTION OF EXEMPLARY EMBODIMENTS

[0045] FIG. 1 shows a wireless communication system to which the present disclosure may be applied. The wireless communication system may be referred to as an Evolved-UMTS Terrestrial Radio Access Network (E-UTRAN) or a Long Term Evolution (LTE)/LTE-A system.

[0046] The E-UTRAN includes at least one base station (BS) 20 which provides a control plane and a user plane to a user equipment (UE) 10. The UE 10 may be fixed or mobile, and may be referred to as another terminology, such as a mobile station (MS), a user terminal (UT), a subscriber station (SS), a mobile terminal (MT), a wireless device, etc. The BS 20 is generally a fixed station that communicates with the UE 10 and may be referred to as another terminology, such as an evolved node-B (eNB), a base transceiver system (BTS), an access point, etc.

[0047] The BSs 20 are interconnected by means of an X2 interface. The BSs 20 are also connected by means of an S1 interface to an evolved packet core (EPC) 30, more specifically, to a mobility management entity (MME) through S1-MME and to a serving gateway (S-GW) through S1-U.

[0048] The EPC 30 includes an MME, an S-GW, and a packet data network-gateway (P-GW). The MME has access information of the UE or capability information of the UE, and such information is generally used for mobility management of the UE. The S-GW is a gateway having an E-UTRAN as an end point. The P-GW is a gateway having a PDN as an end point.

[0049] Layers of a radio interface protocol between the UE and the network can be classified into a first layer (L1), a second layer (L2), and a third layer (L3) based on the lower three layers of the open system interconnection (OSI) model that is well-known in the communication system. Among them, a physical (PHY) layer belonging to the first layer provides an information transfer service by using a physical channel, and a radio resource control (RRC) layer belonging to the third layer serves to control a radio resource between the UE and the network. For this, the RRC layer exchanges an RRC message between the UE and the BS.

[0050] FIG. 2 is a diagram showing a wireless protocol architecture for a user plane. FIG. 3 is a diagram showing a wireless protocol architecture for a control plane. The user plane is a protocol stack for user data transmission. The control plane is a protocol stack for control signal transmission.

[0051] Referring to FIGS. 2 and 3, a PHY layer provides an upper layer (=higher layer) with an information transfer service through a physical channel. The PHY layer is connected to a medium access control (MAC) layer which is an upper layer of the PHY layer through a transport channel. Data is transferred between the MAC layer and the PHY layer through the transport channel. The transport channel is classified according to how and with what characteristics data is transferred through a radio interface.

[0052] Data is moved between different PHY layers, that is, the PHY layers of a transmitter and a receiver, through a physical channel. The physical channel may be modulated according to an Orthogonal Frequency Division Multiplexing (OFDM) scheme, and use the time and frequency as radio resources.

[0053] The functions of the MAC layer include mapping between a logical channel and a transport channel and multiplexing and demultiplexing to a transport block that is provided through a physical channel on the transport channel of a MAC Service Data Unit (SDU) that belongs to a logical channel. The MAC layer provides service to a Radio Link Control (RLC) layer through the logical channel.

[0054] The functions of the RLC layer include the concatenation, segmentation, and reassembly of an RLC SDU. In order to guarantee various types of Quality of Service (QoS) required by a Radio Bearer (RB), the RLC layer provides three types of operation mode: Transparent Mode (TM), Unacknowledged Mode (UM), and Acknowledged Mode (AM). AM RLC provides error correction through an Automatic Repeat Request (ARQ).

[0055] The RRC layer is defined only on the control plane. The RRC layer is related to the configuration, reconfiguration, and release of radio bearers, and is responsible for control of logical channels, transport channels, and PHY channels. An RB means a logical route that is provided by the first layer (PHY layer) and the second layers (MAC layer, the RLC layer, and the PDCP layer) in order to transfer data between UE and a network.

[0056] The function of a Packet Data Convergence Protocol (PDCP) layer on the user plane includes the transfer of user data and header compression and ciphering. The function of the PDCP layer on the user plane further includes the transfer and encryption/integrity protection of control plane data.

[0057] What an RB is configured means a process of defining the characteristics of a wireless protocol layer and channels in order to provide specific service and configuring each detailed parameter and operating method. An RB can be divided into two types of a Signaling RB (SRB) and a Data RB (DRB). The SRB is used as a passage through which an RRC message is transmitted on the control plane, and the DRB is used as a passage through which user data is transmitted on the user plane.

[0058] If RRC connection is established between the RRC layer of UE and the RRC layer of an E-UTRAN, the UE is in the RRC connected state. If not, the UE is in the RRC idle state.

[0059] A downlink transport channel through which data is transmitted from a network to UE includes a broadcast channel (BCH) through which system information is transmitted and a downlink shared channel (SCH) through which user traffic or control messages are transmitted. Traffic or a control message for downlink multicast or broadcast service may be transmitted through the downlink SCH, or may be transmitted through an additional downlink multicast channel (MCH). Meanwhile, an uplink transport channel through which data is transmitted from UE to a network includes a random access channel (RACH) through which an initial control message is transmitted and an uplink shared channel (SCH) through which user traffic or control messages are transmitted.

[0060] Logical channels that are placed over the transport channel and that are mapped to the transport channel include

a broadcast control channel (BCCH), a paging control channel (PCCH), a common control channel (CCCH), a multicast control channel (MCCH), and a multicast traffic channel (MTCH).

[0061] The physical channel includes several OFDM symbols in the time domain and several subcarriers in the frequency domain. One subframe includes a plurality of OFDM symbols in the time domain. An RB is a resources allocation unit, and includes a plurality of OFDM symbols and a plurality of subcarriers. Furthermore, each subframe may use specific subcarriers of specific OFDM symbols (e.g., the first OFDM symbol) of the corresponding subframe for a physical downlink control channel (PDCCH), that is, an L1/L2 control channel. A Transmission Time Interval (TTI) is a unit time for subframe transmission.

[0062] Hereinafter, a new radio access technology (new RAT, NR) will be described.

[0063] As more and more communication devices require more communication capacity, there is a need for improved mobile broadband communication over existing radio access technology. Also, massive machine type communications (MTC), which provides various services by connecting many devices and objects, is one of the major issues to be considered in the next generation communication. In addition, communication system design considering reliability/latency sensitive service/UE is being discussed. The introduction of next generation radio access technology considering enhanced mobile broadband communication (eMBB), massive MTC (mMTC), ultrareliable and low latency communication (URLLC) is discussed. This new technology may be called new radio access technology (new RAT or NR) in the present disclosure for convenience.

[0064] FIG. 4 illustrates a system structure of a next generation radio access network (NG-RAN) to which NR is applied.

[0065] Referring to FIG. 4, the NG-RAN may include a gNB and/or an eNB that provides user plane and control plane protocol termination to a terminal. FIG. 4 illustrates the case of including only gNBs. The gNB and the eNB are connected by an Xn interface. The gNB and the eNB are connected to a 5G core network (5GC) via an NG interface. More specifically, the gNB and the eNB are connected to an access and mobility management function (AMF) via an NG-C interface and connected to a user plane function (UPF) via an NG-U interface.

[0066] FIG. 5 illustrates a functional division between an NG-RAN and a 5GC.

[0067] Referring to FIG. 5, the gNB may provide functions such as an inter-cell radio resource management (Inter Cell RRM), radio bearer management (RB control), connection mobility control, radio admission control, measurement configuration & provision, dynamic resource allocation, and the like. The AMF may provide functions such as NAS security, idle state mobility handling, and so on. The UPF may provide functions such as mobility anchoring, PDU processing, and the like. The SMF may provide functions such as UE IP address assignment, PDU session control, and so on.

[0068] FIG. 6 illustrates an example of a frame structure that may be applied in NR.

[0069] Referring to FIG. 6, a frame may be composed of 10 milliseconds (ms) and include 10 subframes each composed of 1 ms.

**[0070]** One or a plurality of slots may be included in a subframe according to subcarrier spacings.

**[0071]** The following table 1 illustrates a subcarrier spacing configuration  $\mu$ .

TABLE 1

$\mu$	$\Delta f = 2^\mu \cdot 15[\text{kHz}]$	Cyclic prefix
0	15	Normal
1	30	Normal
2	60	Normal
		Extended
3	120	normal
4	240	normal

**[0072]** The following table 2 illustrates the number of slots in a frame ( $N_{slot}^{frame, \mu}$ ), the number of slots in a subframe ( $N_{slot}^{subframe, \mu}$ ), the number of symbols in a slot ( $N_{symb}^{slot}$ ), and the like, according to subcarrier spacing configurations  $\mu$ .

TABLE 2

$\mu$	$N_{symb}^{slot}$	$N_{slot}^{frame, \mu}$	$N_{slot}^{subframe, \mu}$
0	14	10	1
1	14	20	2
2	14	40	4
3	14	80	8
4	14	160	16

**[0073]** In FIG. 6,  $\mu=0, 1, 2$  is illustrated.

**[0074]** A physical downlink control channel (PDCCH) may include one or more control channel elements (CCEs) as illustrated in the following table 3.

TABLE 3

Aggregation level	Number of CCEs
1	1
2	2
4	4
8	8
16	16

**[0075]** That is, the PDCCH may be transmitted through a resource including 1, 2, 4, 8, or 16 CCEs. Here, the CCE includes six resource element groups (REGs), and one REG includes one resource block in a frequency domain and one orthogonal frequency division multiplexing (OFDM) symbol in a time domain.

**[0076]** Meanwhile, in a future wireless communication system, a new unit called a control resource set (CORESET) may be introduced. The terminal may receive the PDCCH in the CORESET.

**[0077]** FIG. 7 illustrates CORESET.

**[0078]** Referring to FIG. 7, the CORESET includes  $N_{CORESET_{RB}}$  number of resource blocks in the frequency domain, and  $N_{CORESET_{symb}} \in \{1, 2, 3\}$  number of symbols in the time domain.  $N_{CORESET_{RB}}$  and  $N_{CORESET_{symb}}$  may be provided by a base station via higher layer signaling. As illustrated in FIG. 7, a plurality of CCEs (or REGs) may be included in the CORESET.

**[0079]** The UE may attempt to detect a PDCCH in units of 1, 2, 4, 8, or 16 CCEs in the CORESET. One or a plurality of CCEs in which PDCCH detection may be attempted may be referred to as PDCCH candidates.

**[0080]** A plurality of CORESETs may be configured for the terminal.

**[0081]** FIG. 8 is a diagram illustrating a difference between a related art control region and the CORESET in NR.

**[0082]** Referring to FIG. 8, a control region **800** in the related art wireless communication system (e.g., LTE/LTE-A) is configured over the entire system band used by a base station (BS). All the terminals, excluding some (e.g., eMTC/NB-IoT terminal) supporting only a narrow band, must be able to receive wireless signals of the entire system band of the BS in order to properly receive/decode control information transmitted by the BS.

**[0083]** On the other hand, in NR, CORESET described above was introduced. CORESETs **801**, **802**, and **803** are radio resources for control information to be received by the terminal and may use only a portion, rather than the entirety of the system bandwidth. The BS may allocate the CORESET to each UE and may transmit control information through the allocated CORESET. For example, in FIG. 8, a first CORESET **801** may be allocated to UE 1, a second CORESET **802** may be allocated to UE 2, and a third CORESET **803** may be allocated to UE 3. In the NR, the terminal may receive control information from the BS, without necessarily receiving the entire system band.

**[0084]** The CORESET may include a UE-specific CORESET for transmitting UE-specific control information and a common CORESET for transmitting control information common to all UEs.

**[0085]** Meanwhile, NR may require high reliability according to applications. In such a situation, a target block error rate (BLER) for downlink control information (DCI) transmitted through a downlink control channel (e.g., physical downlink control channel (PDCCH)) may remarkably decrease compared to those of conventional technologies. As an example of a method for satisfying requirement that requires high reliability, content included in DCI can be reduced and/or the amount of resources used for DCI transmission can be increased. Here, resources can include at least one of resources in the time domain, resources in the frequency domain, resources in the code domain and resources in the spatial domain.

**[0086]** In NR, the following technologies/features can be applied.

**[0087]** <Self-Contained Subframe Structure>

**[0088]** FIG. 9 illustrates an example of a frame structure for new radio access technology.

**[0089]** In NR, a structure in which a control channel and a data channel are time-division-multiplexed within one TTI, as shown in FIG. 9, can be considered as a frame structure in order to minimize latency.

**[0090]** In FIG. 9, a shaded region represents a downlink control region and a black region represents an uplink control region. The remaining region may be used for downlink (DL) data transmission or uplink (UL) data transmission. This structure is characterized in that DL transmission and UL transmission are sequentially performed within one subframe and thus DL data can be transmitted and UL ACK/NACK can be received within the subframe. Consequently, a time required from occurrence of a data transmission error to data retransmission is reduced, thereby minimizing latency in final data transmission.

**[0091]** In this data and control TDMed subframe structure, a time gap for a base station and a terminal to switch from

a transmission mode to a reception mode or from the reception mode to the transmission mode may be required. To this end, some OFDM symbols at a time when DL switches to UL may be set to a guard period (GP) in the self-contained subframe structure.

**[0092]** <Analog Beamforming #1>

**[0093]** Wavelengths are shortened in millimeter wave (mmW) and thus a large number of antenna elements can be installed in the same area. That is, the wavelength is 1 cm at 30 GHz and thus a total of 100 antenna elements can be installed in the form of a 2-dimensional array at an interval of 0.5 lambda (wavelength) in a panel of 5x5 cm. Accordingly, it is possible to increase a beamforming (BF) gain using a large number of antenna elements to increase coverage or improve throughput in mmW.

**[0094]** In this case, if a transceiver unit (TXRU) is provided to adjust transmission power and phase per antenna element, independent beamforming per frequency resource can be performed. However, installation of TXRUs for all of about 100 antenna elements decreases effectiveness in terms of cost. Accordingly, a method of mapping a large number of antenna elements to one TXRU and controlling a beam direction using an analog phase shifter is considered. Such analog beamforming can form only one beam direction in all bands and thus cannot provide frequency selective beamforming.

**[0095]** Hybrid beamforming (BF) having a number B of TXRUs which is smaller than Q antenna elements can be considered as an intermediate form of digital BF and analog BF. In this case, the number of directions of beams which can be simultaneously transmitted are limited to B although it depends on a method of connecting the B TXRUs and the Q antenna elements.

**[0096]** <Analog Beamforming #2>

**[0097]** When a plurality of antennas is used in NR, hybrid beamforming which is a combination of digital beamforming and analog beamforming is emerging. Here, in analog beamforming (or RF beamforming) an RF end performs precoding (or combining) and thus it is possible to achieve the performance similar to digital beamforming while reducing the number of RF chains and the number of D/A (or A/D) converters. For convenience, the hybrid beamforming structure may be represented by N TXRUs and M physical antennas. Then, the digital beamforming for the L data layers to be transmitted at the transmitting end may be represented by an N by L matrix, and the converted N digital signals are converted into analog signals via TXRUs, and analog beamforming represented by an M by N matrix is applied.

**[0098]** FIG. 10 is an abstract schematic diagram illustrating hybrid beamforming from the viewpoint of TXRUs and physical antennas.

**[0099]** In FIG. 10, the number of digital beams is L and the number of analog beams is N. Further, in the NR system, by designing the base station to change the analog beamforming in units of symbols, it is considered to support more efficient beamforming for a terminal located in a specific area. Furthermore, when defining N TXRUs and M RF antennas as one antenna panel in FIG. 7, it is considered to introduce a plurality of antenna panels to which independent hybrid beamforming is applicable in the NR system.

**[0100]** When a base station uses a plurality of analog beams as described above, analog beams suitable to receive signals may be different for terminals and thus a beam

sweeping operation of sweeping a plurality of analog beams to be applied by a base station per symbol in a specific subframe (SF) for at least a synchronization signal, system information and paging such that all terminals can have reception opportunities is considered.

**[0101]** FIG. 11 illustrates the beam sweeping operation for a synchronization signal and system information in a down-link (DL) transmission procedure.

**[0102]** In FIG. 11, physical resources (or a physical channel) in which system information of the NR system is transmitted in a broadcasting manner is referred to as a physical broadcast channel (xBCH). Here, analog beams belonging to different antenna panels can be simultaneously transmitted within one symbol, and a method of introducing a beam reference signal (BRS) which is a reference signal (RS) to which a single analog beam (corresponding to a specific antenna panel) is applied in order to measure a channel per analog beam, as illustrated in FIG. 8, is under discussion. The BRS can be defined for a plurality of antenna ports, and each antenna port of the BRS can correspond to a single analog beam. Here, all analog beams in an analog beam group are applied to the synchronization signal or xPBCH and then the synchronization signal or xPBCH is transmitted such that an arbitrary terminal can successively receive the synchronization signal or xPBCH.

**[0103]** In NR, a synchronization signal block (SSB (= synchronization signal and physical broadcast channel (PBCH))) may be composed of four OFDM symbols in the time domain, numbered in the ascending order from 0 to 3 within the SSB; and a primary synchronization signal (PSS), secondary synchronization signal (SSS), and PBCH associated with demodulation reference signal (DMRS) may be mapped to the symbols. Here, a synchronization signal block may be termed as an SS/PBCH block.

**[0104]** In NR, since a plurality of synchronization signal blocks (SSBs) may be transmitted at different times, respectively, and the SSB may be used for performing initial access (IA), serving cell measurement, and the like, it is preferable to transmit the SSB first when transmission time and resources of the SSB overlap with those of other signals. To this purpose, the network may broadcast the transmission time and resource information of the SSB or indicate them through UE-specific RRC signaling.

**[0105]** From now on, the present disclosure will be described. In what follows, an upper layer signal may refer to a Radio Resource Control (RRC) message, MAC message, or system information.

**[0106]** In NR, beams may be used for transmission and reception. If reception performance of a current serving beam is degraded, a process of searching for a new beam through the so-called Beam Failure Recovery (BFR) may be performed.

**[0107]** Since the BFR process is not intended for declaring an error or failure of a link between the network and a UE, it may be assumed that a connection to the current serving cell is retained even if the BFR process is performed. During the BFR process, measurement of different beams (which may be expressed in terms of CSI-RS port or Synchronization Signal Block (SSB) index) configured by the network may be performed, and the best beam for the corresponding UE may be selected. The UE may perform the BFR process in a way that it performs a RACH process associated with a beam yielding a good measurement result.

**[0108]** The present disclosure proposes a method for configuring a CORESET and search space set required for performing the BFR process from the viewpoint of control channel processing and a candidate mapping method for handling BD/CE complexity. The Transmission Configuration Indication (hereinafter, TCI) state in the present disclosure may be configured for each CORESET of a control channel and may be used as a parameter for determining a reception (Rx) beam.

**[0109]** For each DL BWP of a serving cell, a UE may be configured for three or fewer CORESETs. Also, a UE may receive the following information for each CORESET.

**[0110]** 1) CORESET index  $p$  (one of 0 to 11, where index of each CORESET may be determined uniquely among BWPs of one serving cell),

**[0111]** 2) PDCCH DM-RS scrambling sequence initialization value,

**[0112]** 3) Duration of a CORESET in the time domain (which may be given in symbol units),

**[0113]** 4) Resource block set,

**[0114]** 5) CCE-to-REG mapping parameter,

**[0115]** 6) Antenna port quasi co-location representing quasi co-location (QCL) information of a DM-RS antenna port for receiving a PDCCH in each CORESET (from a set of antenna port quasi co-locations provided by a higher layer parameter called 'TCI-State'),

**[0116]** 7) Indication of presence of Transmission Configuration Indication (TCI) field for a specific DCI format transmitted by the PDCCH in the CORESET, and so on.

**[0117]** Here, 'TCI-State' parameter is associated with a QCL type (there may be QCL type A, B, C, and D; and for description of each type, refer to Table 4) corresponding to one or two downlink reference signals.

TABLE 4

QCL Type	Description
QCL-TypeA	Doppler shift, Doppler spread, average delay, delay spread
QCL-TypeB	Doppler shift, Doppler spread
QCL-TypeC	Doppler shift, average delay
QCL-TypeD	Spatial Rx parameter

**[0118]** Each 'TCI-State' may include a parameter for configuring the quasi co-location relationship between one or two downlink reference signals and DM-RS port of the PDSCH/PDCCH.

**[0119]** For a CORESET with index 0, the UE assumes that a DM-RS antenna port for PDCCH receptions in the CORESET is quasi co-located with i) the one or more DL RS configured by a TCI state, where the TCI state is indicated by a MAC CE activation command for the CORESET or ii) a SS/PBCH block the UE identified during a most recent random access procedure not initiated by a PDCCH order that triggers a non-contention based random access procedure (if no MAC CE activation command indicating a TCI state for the CORESET is received after the most recent random access procedure).

**[0120]** For a CORESET other than a CORESET with index 0, if a UE is provided a single TCI state for a CORESET, or if the UE receives a MAC CE activation command for one of the provided TCI states for a CORESET, the UE assumes that the DM-RS antenna port associated with PDCCH receptions in the CORESET is quasi co-located with the one or more DL RS configured by the

TCI state. For a CORESET with index 0, the UE expects that QCL-TypeD of a CSI-RS in a TCI state indicated by a MAC CE activation command for the CORESET is provided by a SS/PBCH block.

**[0121]** If the UE receives the MAC CE activation command for one of the TCI states, the UE may apply the activation command after 3 msec of a slot that transmits HARQ-ACK information about the PDSCH providing the activation command. An active BWP may be defined as an active BWP in a slot when the activation command is applied.

**[0122]** In one serving cell, the UE may receive 10 or fewer search space sets from each DL BWP configured for the UE. For each search space set, the UE may receive at least one of the following information.

**[0123]** 1) Search space set index  $s$  ( $0 \leq s < 40$ ), 2) association between a CORESET  $P$  and the search space set  $s$ , 3) PDCCH monitoring periodicity and PDCCH monitoring offset (slot unit), 4) PDCCH monitoring pattern within a slot (for example, the pattern indicates the first symbol of the CORESET within a slot for PDCCH monitoring), 5) the number of slots in which the search space set  $s$  exists, 6) the number of PDCCH candidates for each CCE aggregation level, 7) information indicating whether the search space set  $s$  is a CSS or an USS, and 8) DCI format that the UE has to monitor.

**[0124]** [CORESET for BFR and Search Space Set]

**[0125]** During the BFR process, when a UE performs a Random Access Channel (RACH) process by using a resource associated with a beam chosen as the best one, a CORESET and a search space may be used for receiving a required signal from the network, such as a Random Access Response (RAR) message. Until a new CORESET and search space reflecting additionally changed beam information are configured, the UE may receive a UL grant or DL assignment through the BFR CORESET.

**[0126]** <Relationship Between BWP and 'BFR CORESET and Search Space Set'>

**[0127]** In NR, a maximum of three CORESETs and 10 search space sets may be configured for each Bandwidth Part (BWP). At this time, scheduling flexibility may be increased by making each CORESET have different CORESET properties (for example, CCE-to-REG mapping (with or without interleaving), REG bundle size (for example, 2, 3, 6 REGs), and wideband (WB)/narrow band (NB) reference signal) and making each search space set have a different monitoring occasion (in what follows, which may also be called a monitoring time), different aggregation level (AL), and different number of candidates. A UE monitors a set of PDCCH candidates in one or more CORESETs on an activated DL BWP of each activated serving cell for which PDCCH monitoring is configured according to the corresponding search space sets. Here, monitoring refers to decoding each of the PDCCH candidates according to the DCI format.

**[0128]** In the case of a BFR CORESET, (irrespective of scheduling flexibility of the aforementioned PDCCH transmission and reception) since it is necessary for a process of searching for a new beam because of degradation of beam reception performance, it may be preferable not to apply the restriction corresponding to the maximum number of CORESETs per BWP (namely the restriction that allows 3 CORESETs for each BWP) to the BFR CORESET. In other words, the UE may be configured with 3 CORESETs

excluding the BFR CORESET for each BWP and 10 search space sets excluding the BFR search space set. When a normal CORESET is reused for the BFR CORESET, if the normal CORESET is configured for a use rather than the BFR, the BFR CORESET may be included in the maximum number of CORESETs for each BWP. This scheme may be applied the same for the search space set.

**[0129]** The BFR CORESET may be configured for each BWP or may be configured by the initial BWP. When the BFR CORESET is configured for each BWP, the corresponding configuration for each BWP may be applied, otherwise the BFR CORESET of the initial BWP may be monitored.

**[0130]** In addition, besides the following methods, a previously configured CORESET and/or CORESET that associates a search space set with the BFR and/or search space set may be reused. In this case, part of parameters of the CORESET configuration and/or search space set configuration may be newly configured. For example, for the case of a parameter such as the TCI state in the CORESET configuration, irrespective of a previous configuration, it may be assumed that in the BFR CORESET, the best beam is defined from the measurement of a UE or by the RACH process performed by the UE in the BFR process.

**[0131]** <Case where the BFR CORESET is Configured for Each BWP>

**[0132]** 1) A BFR CORESET may always be configured for a BWP (namely, an active BWP) for which a UE maintains transmission and reception to and from the current network. This may be implemented through such a method that includes information about the BFR CORESET within the BFR configuration. Also, a monitoring occasion of the BFR CORESET may be determined by a PRACH transmission time due to BFR. For example, the monitoring occasion of the BFR CORESET may be given by each slot within a Random Access Response (RAR) monitoring window after the PRACH transmission slot index plus 4.

**[0133]** 2) It may be preferable to consider/recognize that a connection to a serving cell is maintained even if the BFR process is under progress. Therefore, a UE may perform not only monitoring of the BFR CORESET but also monitoring of DCI according to a previously configured CORESET and search space set configuration. For example, in the BFR CORESET, it may be defined in a way to monitor only the PDCCH scrambled with C-RNTI. In this case, since there are times that the information allocated with a unique RNTI such as slot format indicator or slot format index (SFI), system information (SI), or paging is not transmitted to the UE, it may be preferable to maintain monitoring of an existing CORESET. At this time, a method for configuring actual candidates by which a UE performs monitoring will be described later.

**[0134]** <Case where the BFR CORESET is Configured for the Initial BWP>

**[0135]** 1) The initial BWP may be basically configured with a CORESET configured by the PBCH (CORESET #0) and CORESET configured for the RACH process (CORESET #1); and if the CORESET #1 is not configured, the CORESET #0 may be reused for the CORESET #1.

**[0136]** 2) When conventional DCI monitoring is performed, the UE may have to perform monitoring of different BWPs in the same slot to monitor the previous DCI. In this case, the following methods (options) may be considered.

**[0137]** Option 1) Monitoring of a BFR CORESET is considered to be a special case, and even when an active BWP does not coincide with the initial BWP, DCI monitoring for the BFR and monitoring of a previously configured DCI may all be performed.

**[0138]** Option 2) When a BWP performing DCI monitoring of BFR is different from a previous active BWP, DCI monitoring of the previous active BWP may not be performed. Only when the BWP performing DCI monitoring of BFR is the same as a previous active BWP, a method for performing monitoring of a previous DCI may be included.

**[0139]** 3) When a BFR CORESET is configured for the initial BWP, the BFR CORESET may be indicated by using the following method (option).

**[0140]** Option 1) Reuse of CORESET #0 or CORESET #1

**[0141]** A BFR CORESET may be predefined or the network may configure a BFR CORESET to reuse a previously defined CORESET through higher layer signaling.

**[0142]** If the CORESET #0 is reused as a BFR CORESET, and BFR process is performed based on the CSI-RS port, the network may signal the relationship between each CSI-RS port used in the BFR process and the SSB index associated with the CORESET #0. For example, a mapping relationship between the CSI-RS port used in the BFR process and the SSB index may be indicated through higher layer signaling.

**[0143]** Option 2) New CORESET for BFR

**[0144]** The network may indicate/provide a configuration for a BFR CORESET defined within the initial BWP to each UE, and an indication/provision method may use a broadcast signal or UE-dedicated signal.

**[0145]** In the case of a BFR CORESET/SS, configuration may be optional. Therefore, if the BFR CORESET/SS is not configured within the corresponding active BWP, or a BFR Contention Free Random Access (CFRA) resource is not configured, a UE may perform the following operation.

**[0146]** 1) Beam recovery may be performed along a Contention Based Random Access (CBRA) resource. An RAR CORESET/SS associated with the corresponding CBRA resource may be assumed to be a BFR CORESET, in which a response reception for a plurality of beams may be expected.

**[0147]** 2) A response reception for a plurality of beams may be expected through an RAR CORESET/SS associated with the CBRA resource.

**[0148]** 3) A CFRA/CBRA/RAR CORESET/SS resource may be used by returning to the initial DL/UL BWP. Or, this option may be applied only to the case where a BFR CORESET/SS or CFRA resource does not exist within the corresponding active DL/UL BWP.

**[0149]** [Blind Decoding and Channel Estimation Complexity on BFR Process]

**[0150]** In NR, monitoring of a plurality of CORESETs and search space sets may be configured for the same slot. Therefore, the maximum number of blind decoding (BD) and channel estimation that may be performed within one slot may be defined by considering complexity of a UE, and those slots that exceed the corresponding maximum value may not perform monitoring for part of the search space set/monitoring candidates. To perform monitoring of a BFR CORESET smoothly, a slot that performs monitoring of the BFR CORESET may configure a candidate that needs to be monitored as follows (currently, for normal slots, BD and channel estimation for a common search space (CSS) are performed first, and it is assumed that the limit due to the

CSS is not exceeded. Afterwards, candidate selection (or mapping) at the search space set level is performed for a UE-specific search space (USS), and it is assumed that a lower search space index has higher priority for a plurality of USSs).

**[0151]** <Priority of BFR Search Space Set>

**[0152]** 1) Monitoring of a BFR search space set may be designated as the highest priority. i) Since serving beam configuration has to be performed first in the BFR process, monitoring of candidates belonging to a search space set related to BFR has to be performed. ii) Therefore, a search space set related to BFR (for example, a response with respect to the PRACH transmitted by a UE during the BFR process and a subsequent process) may configure the highest priority irrespective of the type (for example, CSS/USS) of the corresponding BFR search space set, and it may be assumed that no candidate belonging to the corresponding search space set exceeds the limit.

**[0153]** 2) Monitoring of a BFR search space set may be performed separately from BD per slot and CCE limit. For BFR-related DCI, decoding may not necessarily have to be completed within a slot that receives the DCI. Therefore, previously configured DCI monitoring may be performed continuously by considering BD per slot and CCE limit, and monitoring of an SFR search space set may be performed independently. At this time, it may be assumed that the BD and the number of CCEs configured by the BFR search space set do not exceed the limit.

**[0154]** <Assumption on CSSs>

**[0155]** As described above, for normal slots (in other words, slots that do not perform the BFR process), it may be assumed that configured common search spaces do not exceed the maximum number of BDs and CCEs.

**[0156]** However, since the number of BD/CCEs for BFR monitoring is added when a BFR CORESET is monitored, there may be chances that the BD/CCE limit may be exceeded when the BD/CCEs due to existing common search spaces are taken into account. Therefore, the following assumption may be applied for a slot that monitors a BFR search space set. The following options may be implemented separately or in the form of a combination thereof. The following options may be applied only to a common search space, but an USS according to a previous configuration may not be monitored during the BFR process. Or a candidate for monitoring may be chosen among common search spaces according to the following options, and if there is room for BD/CCE, the PDCCH may still be mapped to the search space set with respect to the USS afterwards.

**[0157]** Option 1) It may be assumed that previously configured common search spaces do not exceed the BD and CCE limit even in a BFR slot. This may indicate that even if the network performs BD and channel estimation in the BFR slot for a candidate related to BFR, the number of BDs and CCEs for the common search spaces are set at least not to exceed a limit configured previously.

**[0158]** Option 2) If the number of BDs and CCEs in the common search spaces exceeds a limit configured previously due to the number of BDs and CCEs due to a BFR search space set, search space set level drop may be applied for the common search space(s). At this time, priority among search space sets may be determined by search space index (for example, it is assumed that a low (high) search space index has high priority), DCI format (for example, priority is defined for each DCI format), and so on.

**[0159]** For example, suppose a BD limit and a CCE limit defined within one slot are denoted by  $X_{slot}$  and  $Y_{slot}$  respectively; and the numbers of BDs and CCEs configured for a BFR search space set are denoted by  $X_{BFR}$  and  $Y_{BFR}$ . Then the numbers of BDs and CCEs allowed for the common search space(s) configured for the corresponding slot may be obtained by  $X_{CSS}(=X_{slot}-X_{BFR})$ ,  $Y_{CSS}(=Y_{slot}-Y_{BFR})$ , respectively. At this time, among common search spaces configured for the corresponding slot, if the numbers of BDs and CCEs of a common search space set having the highest priority are smaller than  $X_{CSS}$  and  $Y_{CSS}$ , blind decoding of the corresponding common search space may be performed. Afterwards,  $X_{CSS}$  and  $Y_{CSS}$  values are updated, and the corresponding process may be repeated for a common search space having the second highest priority until one of the two limits is exceeded. BD may not be performed for a common search space that exceeds the limit.

**[0160]** Candidate drop at a candidate level may also be included in the option 2).

**[0161]** Option 3) If monitoring of a BFR search space set and one or more common search space sets is configured in a specific slot; and the number of BDs and/or CCEs due to the BFR search space set and the number of BDs and/or CCEs due to the common search space set(s) exceed the corresponding limit, monitoring of the common search space may not be performed.

**[0162]** Option 4) Monitoring of a BFR CORESET/SS may be included additionally to UE capability. In other words, a BFR CORESET/SS may assume that a UE is additionally capable of performing channel estimation/BD beyond its previous capability as much as configured and may not consider channel estimation/BD limit. This indicates that capability with respect to a BFR CORESET and search space set may be defined separately, or that BFR-related BD/channel estimation is assumed to be always performed independently of BD/channel estimation for a normal DCI. A limit for BD and channel estimation may be applied to the remaining CORESETs/search space sets except for the BFR CORESET/search space set.

**[0163]** Option 5) In a slot where monitoring of a BFR CORESET is performed, it may be predefined or indicated through higher layer signaling so that only a candidate corresponding to a specific RNTI among candidates of an existing CORESET/search space set is monitored. For example, in a slot where monitoring of a BFR CORESET is performed, it may be configured so that only a PDCCH candidate related to SFI from a previously configured CORESET/search space set is monitored. In addition, if the BD/CCE limit is exceeded at the time of monitoring of an existing CORESET, monitoring of the existing CORESET may not be performed.

**[0164]** Option 6) In a slot where a BFR CORESET has to be monitored, it may be predefined or indicated through higher layer signaling so that monitoring of other CORESETs except for the BFR CORESET is not performed.

**[0165]** [Rx Beam Priority]

**[0166]** As described above, in NR, limits for the numbers of BDs and CCEs are defined in terms of UE complexity, and if the corresponding limits are exceeded in a specific slot, monitoring of part of monitoring candidates may be skipped. A method based on the operating scheme above may also be applied for an Rx beam used for specific time resources.

**[0167]** In NR, monitoring of a plurality of CORESETs may be performed in the same slot, and at this time, the CORESETs may be overlapped with each other in the time/frequency domain. Also, for each CORESET, a different Quasi Co-Location (QCL) assumption may be applied (namely, TCI state for a PDCCH may be set differently for each CORESET). This implies that a plurality of CORESETs that have to receive different Rx beams at the same symbol may be included, and a UE having one RF panel (namely a UE capable of receiving only one Rx beam from a specific time resource) has to select one of a plurality of Rx beams. Receiving a signal by using a specific Rx beam may indicate that a spatial filter is applied for receiving a specific signal from a viewpoint of UE implementation. The aforementioned QCL assumption or TCI may be regarded as information related to the spatial filter application.

**[0168]** The present disclosure proposes a method for configuring one Rx beam among a plurality of Rx beams. This operational scheme of the proposed method may be interpreted so that when a plurality of TCI states are set to the same time domain resource, priorities of the corresponding TCI states are configured, and a TCI state having the highest priority is applied to the corresponding time domain resource. Also, this operational scheme may also be interpreted as configuring priorities of a plurality of CORESETs overlapping in the time domain.

**[0169]** If an Rx beam that a UE applied is determined (or TCI state is determined) by the following method, network may perform transmission in the CORESET associated with the corresponding Rx beam, or in the case of a CORESET in which an improper Rx beam is used, reception performance may be compensated for through coding rate or power boosting.

**[0170]** FIG. 12 illustrates a PDCCH monitoring method of a UE according to one embodiment of the present disclosure.

**[0171]** Referring to FIG. 12, the UE identifies whether PDCCH monitoring occasions are overlapped in a plurality of CORESETs (S100).

**[0172]** Based on the PDCCH monitoring occasions being overlapped, the UE selects at least one CORESET from the plurality of CORESETs (S200).

**[0173]** The UE performs PDCCH monitoring only in the selected at least one CORESET (S300).

**[0174]** In what follows, specific options (methods) for selecting at least one CORESET among the plurality of CORESETs are described. In what follows, for the convenience of descriptions, each option is described separately, but the following options may be used separately or in the form of a combination thereof.

**[0175]** Option 1) Measurement-Based Priority

**[0176]** A UE may configure an Rx beam at the corresponding time resource based on measurement and report result. For example, one symbol in the time domain may be mapped to three CORESETs in the frequency domain. In other words, three CORESETs may overlap in the time domain. In this case, when QCL assumption is different for each CORESET, an Rx beam at the corresponding symbol may be configured based on the best measurement result among measurement results associated with the respective CORESETs. As one example, an Rx beam (or TCI state) associated with a CORESET having the highest RSRP value among the RSRP values measured from the respective CORESETs (or RSRP value of a signal configured to a TCI state of each CORESET) may be applied to the correspond-

ing symbol. In option 1, an Rx beam may be determined based on current measurement of a UE or determined based on a measurement result most recently reported. By reporting a value measured from each CORESET to a gNB, the UE may let the gNB (network) know the Rx beam to be selected by the UE.

**[0177]** Option 2) Priority Based on CORESET/Search Space Set Index

**[0178]** By assigning priority to a CORESET index or search space set index, Rx beam to be applied to the corresponding resource may be determined. For example, a UE may configure an Rx beam based on a CORESET with the lowest (or highest) CORESET index or the TCI state of a CORESET associated with the lowest search space set index.

**[0179]** Option 3) Message-Based Priority

**[0180]** A UE may configure an Rx beam based on the priority (for example, DCI format, RNTI, and BFR) of a message that has to be monitored in each CORESET. For example, an Rx beam of a CORESET monitoring DCI related to SFI, pre-emption, and so on may have higher priority than an Rx beam of a CORESET monitoring non-fallback DCI.

**[0181]** As another example, an Rx beam of a CORESET monitoring information needed for maintaining communication of a UE such as RACH/SI update/paging may be configured to have higher priority.

**[0182]** As yet another example, the search space set type such as CSS/USS may be considered as an element for determining priority. More specifically, CSS may have higher priority than USS.

**[0183]** For the case of a CORESET related to beam failure recovery (or beam management), the highest priority may be assigned irrespective of the CORESET priority within a slot that has to perform monitoring.

**[0184]** FIG. 13 illustrates a specific example of selecting a specific CORESET from a plurality of CORESETs when using options 2 and 3.

**[0185]** Referring to FIG. 13, a CORESET corresponding to a CSS set of a lowest index from a cell of a lowest index containing a CSS is selected (S201), and PDCCH monitoring is performed in the selected CORESET and a CORESET (e.g., a CORESET having the same QCL characteristic (e.g., QCL-typeD)) using the same reception beam as that of the selected CORESET (S202).

**[0186]** Each step of FIG. 13 will be described in more detail.

**[0187]** For example, i) if a UE is configured for single cell operation or for operation with carrier aggregation in the same frequency band, ii) if the UE monitors PDCCH candidates in overlapping PDCCH monitoring occasions in multiple CORESETs that have same or different QCL properties (for example, QCL-TypeD properties) on active DL BWP(s) of one or more cells, the UE may monitor the PDCCH only in the CORESET corresponding to the CSS set with the lowest index in the cell with the lowest index containing CSS (if there exists other CORESET from the multiple CORESETs having same QCL properties (QCL-TypeD properties) as the CORESET, the other CORESET is also included).

**[0188]** The lowest USS set index may be determined for all of the USS sets having at least one PDCCH candidate among overlapped PDCCH monitoring occasions.

**[0189]** In other words, a UE that monitors a plurality of search spaces (sets, in what follows, the same) associated with different CORESETs may perform a single cell operation or a carrier aggregation operation within the same frequency band. In this case, if monitoring occasions of the search space (set) overlap in the time domain, and the search spaces are associated with different CORESETs having different QCL-TypeD properties, the UE monitors the PDCCH in a CORESET corresponding to (including) a CSS (set) with the lowest index in an active DL BWP of a serving cell with the lowest serving cell index containing the CSS. At this time, the UE may monitor a different CORESET with the same QCL-TypeD properties as the QCL-TypeD properties of the given CORESET. For example, if two or more CORESETs include a CSS (set) respectively, the UE may select a CORESET that includes a search space with the lowest index (or ID) among monitoring occasions in an active DL BWP of a serving cell with the lowest serving cell index. At this time, the UE may monitor overlapping search spaces associated with CORESETs having the same QCL-TypeD properties as the CORESET.

**[0190]** If none of CORESETs includes a CSS, a UE may select a CORESET that includes an USS with the lowest index (or ID) at a monitoring occasion in an active DL BWP of a serving cell with the lowest serving cell index. At this time, the UE may monitor overlapping search spaces associated with the CORESETs having the same QCL-TypeD properties. To this purpose, when a CSI-RS originates from an SSB, the QCL-TypeD for the SSB and QCL-TypeD for the CSI-RS (or TRS) may be regarded as being different from each other.

**[0191]** Meanwhile, an unselected search space may be regarded as dropping the whole search space (rather than puncturing that does not monitor only the overlapping part of the search space).

**[0192]** Allocation of non-overlapping CCEs and PDCCH candidates for PDCCH monitoring may be determined according to the entire search space sets associated with a plurality of CORESETs on active DL BWP(s) of one or more cells. The number of active TCI states may be determined from the plurality of CORESETs.

**[0193]** The UE may decode a PDSCH according to a (detected) PDCCH that includes DCI of the UE and may be configured with a list that includes up to M TCI-state configurations within a higher layer parameter called 'PDSCH-config' for the decoding. And the M value may be dependent on the UE capability (for example, the maximum number of TCI states that may be activated for each BWP).

**[0194]** Here, each TCI state may include parameters for configuring a quasi co-location (QCL) relationship between (one or two) reference signals and DM-RS ports of the PDSCH. The quasi co-location relationship may be configured by the higher layer parameter qcl-Type1 for a first downlink reference signal (DL RS) and (if configured) the higher layer parameter qcl-Type2 for a second downlink reference signal (DL RS). QCL types may not be the same for the two downlink reference signals. The quasi co-location type corresponding to each downlink reference signal may be given by a higher layer parameter qcl-Type (which is included in the QCL-Info) and may be one of QCL-TypeA, QCL-TypeB, QCL-TypeC, and QCL-TypeD.

**[0195]** A UE may receive an activation command that is used for mapping up to 8 TCI states to the code points of DCI field 'Transmission Configuration Indication'. If an

HARQ-ACK corresponding to a PDSCH that carries the activation command is transmitted from slot n, mapping between the code point of the DCI field 'Transmission Configuration Indication' and the TCI state may be applied after a predetermined time period is passed (for example, from slot  $n+3N_{subframe,slot}+1$ ). After receiving an initial higher layer configuration of the TCI state and before receiving the activation command, the UE may assume that DM-RS ports of a PDSCH of a serving cell are at a quasi co-location with an SS/PBCH block determined from the initial access procedure for 'QCL-TypeA'. If applicable, the operation above may be the same for 'QCL-TypeD'.

**[0196]** FIG. 14 illustrates a PDCCH monitoring method when using the above-described options 2 and 3.

**[0197]** Referring to FIG. 14, two serving cells, i.e., a first cell, which is a serving cell index #N and a second cell, which is a serving cell index #N+1, may be set to the terminal. It is assumed that a first CORESET 111 and a second CORESET 112 are set to an activated DL BWP of the first cell and that a third CORESET 113 is set to an activated DL BWP of the second cell. Different CSSs may be associated with the first CORESET 111 and the second CORESET 112, and an USS may be associated with the third CORESET 113. TCI status/setting may be indicated/provided for each CORESET.

**[0198]** It is assumed that the first CORESET 111 and the second CORESET 112 are CORESETs having the same TCI state (i.e., the same QCL characteristic (e.g., QCL-TypeD)) and have a TCI state different from that of the third CORESET 113.

**[0199]** In this case, as described in option 3, because the CSS has a higher priority than that of the USS, the terminal selects the first CORESET 111 and the second CORESET 112 of the first cell including the CSS. Thereafter, as described in option 2, a CORESET including a CSS having a low index, for example, the first CORESET 111 may be selected, wherein PDCCH monitoring may be performed. In this case, as an exception, because the first CORESET 111 and the second CORESET 112 have the same QCL characteristic (QCL-TypeD), the second CORESET 112 may also perform PDCCH monitoring.

**[0200]** Option 4) Priority Due to Time Order of Monitoring Occasions

**[0201]** A UE may apply an Rx beam associated with a first encountered search space set according to a search space set monitoring order of each CORESET. In other words, priority of each CORESET may be determined according to a start symbol index of the CORESET. If the same CORESET is associated to a plurality of search space sets and has the same start symbol, an Rx beam may be determined based on the priority such as a search space set index.

**[0202]** In other words, as the start symbol index of an associated CORESET among search space sets that have to be monitored becomes lower (or higher), the associated CORESET may have high priority.

**[0203]** Option 5) Priority of a CORESET may be determined according to the number of search space sets associated with the CORESET.

**[0204]** As described above, in NR, 3 CORESETs and 10 search space sets may be configured for each BWP, which indicates that a plurality of search space sets may be associated with one CORESET. Option 5 is related to a method for allocating high priority to a CORESET with which a large number of search space sets are associated

under a condition where a plurality of search space sets associated with a plurality of CORESETs have to be monitored in a specific slot, and TCI state of each CORESET is different from each other. At this time, the number of associated search space sets may be limited to the search space sets that perform monitoring in the corresponding slot.

**[0205]** Option 6) Priority of a CORESET may be determined based on TCI state.

**[0206]** In other words, priority may be determined by the TCI state set to each CORESET. As one example, among TCI states set by an RRC signal, the TCI state with a lower (or higher) index may be set to have higher priority. Or to apply the most recent information of a channel status, the TCI state that has most recently been configured in time order may be set to have the highest priority. A gNB may inform of part of TCI states (for example, 8) among a plurality of predetermined TCI states (for example, 64) through an RRC message and inform of one from among the part of TCI states through a MAC CE. Or, the gNB may directly inform of one from among a plurality of predetermined TCI states through an RRC message.

**[0207]** In another method, priority may be determined according to a method for determining the TCI state of each CORESET, which may be regarded as a method that puts high priority to the TCI state in which channel change may be quickly dealt with. For example, a CORESET for which the TCI state is chosen through MAC CE signaling from among a plurality of TCI states indicated by an RRC signal for a specific CORESET may have higher priority than a CORESET for which the TCI state is configured only through RRC signaling.

**[0208]** In addition, when a priority rule is determined as proposed above, a CORESET with low priority may have reduced monitoring occasions in a way that monitoring is not performed in a slot where overlap is occurred or may experience performance degradation with an increased frequency. Therefore, the present disclosure additionally proposes to change the priority rule periodically or non-periodically. This change may be performed in a predefined manner or by an indication of the network. For example, a slot (subframe or frame) index may be used as a criterion for changing the priority rule. As one example, if the option 2) is applied, and the slot index is an odd number, high priority is set to the CORESET associated with a search space set with a low index while, if the slot index is an even number, high priority may be set to the CORESET associated with a search space set with a high index. Then an advantage may be obtained that monitoring occasions for a specific CORESET or a specific search space set are prevented from being reduced due to priority.

**[0209]** The descriptions above propose a method for selecting which TCI state to configure an Rx beam when CORESETs having different TCI states on a specific time resource are configured the same. When a CORESET has both of the time resource overlapping a different CORESET and the time resource existing only in the corresponding CORESET, the present disclosure additionally proposes a method for configuring an Rx beam with respect to each region.

**[0210]** FIG. 15 illustrates a case where two different CORESETs configured with different TCI states overlap each other in the time domain.

**[0211]** As shown in FIG. 15, when monitoring is performed on each CORESET, a UE applies different Rx

beams, and when two CORESETs are overlapped, an Rx beam that has to be applied by the UE (or TCI state that has to be assumed by the UE) may be determined according to the proposed priority rule.

**[0212]** For example, if the priority of CORESET #2 of FIG. 15 is high, a UE may apply Rx beam #1 in the overlapped region. However, in this case, which Rx beam to use for reception has to be determined at symbol #2 of CORESET #3. To this purpose, the present disclosure proposes the following options, which may be implemented separately or in the form of a combination thereof. To configure an Rx beam of a specific CORESET may indicate to configure an Rx beam suitable for the TCI state of the corresponding CORESET.

**[0213]** In addition, the following options may be performed for each set of a CORESET for each slot. For example, each set may be composed of CORESETs overlapped partly or completely with each other in the time domain, and all of the CORESETs existing within one slot may comprise one set.

**[0214]** Option 1) Configuration of Rx Beam According to Priority for Each Time Resource

**[0215]** Based on the TCI state of a CORESET with the highest priority at each time resource (for example, OFDM symbol), an Rx beam at the corresponding time resource may be configured. In this case, there are times that the same precoding may not be assumed for neighboring symbols due to different Rx beams within the same CORESET, and it may be assumed that time domain REG bundling is not applied in the corresponding CORESET. Or it may be assumed that time domain bundling is applied only within a time resource that uses the same Rx beam.

**[0216]** Option 2) It is related to a method for applying an Rx beam with respect to a CORESET with the highest priority among overlapping CORESETs to a plurality of CORESETs including the overlapped region.

**[0217]** With respect to the CORESETs including the same time resource, option 2 may configure an Rx beam for the entire overlapping CORESETs based on the TCI state of a CORESET with the highest priority among the corresponding CORESETs. It may indicate that CORESETs not overlapped in the time domain (for example, at symbol level) may configure an Rx beam based on the TCI state of each CORESET.

**[0218]** Option 3) When a plurality of CORESETs having different TCI states in one slot exist, the TCI state of a CORESET determined to have the highest priority according to the proposed priority rule may be applied to the whole of the corresponding slots. It may indicate that when different CORESETs configured with different TCI states are monitored in the same slot, a CORESET with low priority may change an Rx beam only for the case of the corresponding slot (namely by assuming a TCI state different from the configuration).

**[0219]** Option 4) It may be assumed that a UE performs monitoring only for candidates of search space sets belonging to a CORESET with the highest priority when CORESETs configured with different TCI states are overlapped partly or completely in the time domain. Also, it may indicate that monitoring of CORESETs not overlapped in the time domain may have to be performed according to the configuration. Or it may be interpreted that when CORESETs that have to assume different Rx beams in the corre-

sponding slot are overlapped, monitoring is performed only for a CORESET with the highest priority over the whole of the corresponding slot.

[0220] When a BFR CORESET/search space set has to be monitored, and the TCI state at the corresponding BFR CORESET is different from an existing CORESET (namely a CORESET/search space set configured to perform monitoring before BFR), the option 4 may include a case where the corresponding slot performs monitoring of only the BFR CORESET. Also, the option may include a case where existing CORESETs and BFR CORESET are monitored in the same slot, and when a particular CORESET among the existing CORESETs uses the same Rx beam as the BFR CORESET, monitoring of the corresponding CORESET is performed.

[0221] For example, according to options 2 and 3 described with reference to FIGS. 12 to 14, the UE may select a first CORESET including a search space having a lowest index (or ID) in the monitoring opportunity in an activated DL BWP of a serving cell having a lowest serving cell index. In this case, overlapped search spaces associated with other CORESETs having the same QCL-typeD characteristics as that of the first CORESET may also be monitored, and when there is a CORESET using the same reception beam as that of the first corset, it may mean that PDCCH monitoring is performed in the CORESETs. That is, the option 4 may be used in combination with the options 2 and 3 described with reference to FIGS. 12 to 14.

[0222] <QCL Assumption for CORESET without TCI-State PDCCH>

[0223] Information Element (IE) called "ControlResourceSet" may be provided for each CORESET. And to provide a QCL relationship between a CORESET and DL RS/SSB, a parameter called "tci-StatesPDCCH" may be configured within the IE.

[0224] However, since the "tci-StatesPDCCH" is an optional parameter, the parameter may not be configured for part of a plurality of CORESETs. Such a CORESET may be referred to as a TCI-less CORESET, and a default QCL assumption is needed to determine an Rx beam for receiving a PDCCH in a TCI-less CORESET.

[0225] With respect to a TCI-less CORESET, a UE may assume QCL from a CORESET for which the most recent RACH process has been applied as the default QCL.

[0226] With respect to a BFR-CORESET (for a beam failure recovery process), a UE may assume that a DL RS of a candidate beam identified by the UE upon request of beam failure recovery and the dedicated CORESET are spatially QCLed.

[0227] In terms of PDCCH, for a BFR-CORESET, it may indicate that implicit spatial QCL update (irrespective of CORESET configuration) through beam failure recovery and/or beam management process is assumed.

[0228] Besides the BFR-CORESET, it is necessary to clarify which CORESET is not associated with TCI states. For example, CORESET #0 (by PBCH) and CORESET #1 (by RMSI) may not be associated with TCI states. In general, it is preferable that TCI states are configured in the case of other CORESETs for USS operations.

[0229] It is also necessary to clarify whether a RACH process may include free-contention. Free-contention may be implemented based on a CSI-RS without involving an SSB, and QCL associated with the CSI-RS may not be reliable for CORESET #0 and/or CORESET #1. Therefore,

it may be safer to change QCL information based on the recent contention-based RACH process at least for the CORESET #0 and the CORESET #1.

[0230] In other words, a QCL assumption derived from the most recently performed RACH process may be applied to the CORESET for which 'tci-StatesPDCCH' has not been configured.

[0231] In what follows, more specifically, a method for deriving a QCL assumption is proposed additionally. In what follows, contention-based RACH may indicate that a RACH process at a resource associated with the best SSB (from a measurement result) is performed based on SSBs. A contention-free RACH process may indicate a case where a RACH process is performed at a resource associated with a CSI-RS port (or SSB) by signaling of a gNB.

[0232] Since a contention-free RACH process is based on a network configuration, signaling may be performed irrespective of measurement, or the network may perform signaling based on a measurement report of a UE. Also, in the case of a CSI-RS port, association with an SSB may or may not be signaled. In other words, a contention-free RACH process may not be able to confirm association with an SSB and reflection of a measurement result. This may act as a factor that degrades, in conjunction with an SSB, performance of the operation of a CORESET and CORESET #0 and #1 for which a search space set may be configured. For example, there are times that a UE configures an Rx beam based on the assumption of an erroneous transmission beam.

[0233] 1. A UE may apply a QCL assumption derived from the most recently performed RACH process to a TCI-less CORESET irrespective of the type (namely contention-based/contention-free RACH process) of RACH process.

[0234] 2. A UE may apply the QCL assumption of a TCI-less CORESET only to the result derived from the most recently performed contention-based RACH process. For example, if the most recently performed RACH process is in fact contention-free, the UE may ignore the corresponding result and apply the QCL assumption derived from the most recently performed contention-based RACH process to the corresponding CORESET.

[0235] 3. For each CORESET, a QCL assumption of a different RACH process may be used. For example, CORESET #0 (and/or #1) may apply the QCL assumption derived from the most recently performed contention-based RACH process while the remaining CORESETs may derive a QCL assumption from the most recently performed RACH process irrespective of contention.

[0236] As another example, a CORESET for which a CSS is configured may apply a QCL assumption derived from the most recently performed contention-based RACH process while a CORESET for which a USS is configured may derive a QCL assumption from the most recently performed RACH process irrespective of contention. At this time, a QCL assumption may be applied, which is derived from the most recently performed contention-based RACH process of a CORESET for which both of the CSS and USS are configured.

[0237] 4. Even though the proposed methods are based on a contention-free RACH process, if an associated SSB is indicated, or an implicitly associated SSB is known, a QCL assumption derived from the corresponding contention-free RACH process may be applied to a TCI-less CORESET.

[0238] In addition, according to the present disclosure, through higher layer signaling, the network may inform a UE of from which RACH process type a QCL assumption is derived with respect to a TCI-less CORESET. At this time, a method for informing a UE of the SSB information associated with a CSI-RS port given during a contention-free RACH process may also be included.

[0239] <QCL Assumption Between Overlapped CORESETs in Time Domain>

[0240] Each CORESET may have its own QCL assumption. And different CORESETs may be overlapped in the time domain and/or frequency domain. This may indicate that CORESETs having different QCL assumptions may be overlapped in the same symbol.

[0241] A UE determines an Rx beam for monitoring each CORESET by taking into account the TCI state of the CORESET. Therefore, if CORESETs having different QCL assumptions are overlapped at a resource in the time domain (for example, OFDM symbol), the UE may have to support a plurality of Rx beams or have to select one Rx beam (or TCI state) according to a specific selection rule. Until now, UEs that use a plurality of Rx beams are not considered. Therefore, the following options may be considered.

[0242] Option 1) Skip Monitoring of a CORESET with Low Priority

[0243] A CORESET selection rule may be applied when CORESETs having different (spatial) QCLs are overlapped at a time resource. And a UE may skip monitoring candidates included in an unselected CORESET. Priority of each CORESET may be determined according to, for example, CORESET ID, the number of search space sets associated with the CORESET, and associated search space type. Search space type may be divided into Common Search Space (CSS) and UE-specific Search Space (USS). A monitoring occasion for a PDCCH may be configured by a combination of a CORESET and a search space set associated with the CORESET. For example, a CSS may be associated with a first CORESET, and an USS may be associated with a second CORESET; and when the first and the second CORESETs are overlapped in the time domain, a UE may monitor only the first CORESET. This has been described in detail with reference to FIGS. 13 and 14.

[0244] Option 2) Representative Spatial QCL for Overlapped CORESETs

[0245] Option 2 may arrange overlapped CORESETs according to the priority rule of the option 1 and change the QCL state in a CORESET with low priority instead of deleting the CORESET with low priority. In other words, for overlapped CORESETs, the same spatial QCL is assumed, and by using the CORESET priority mentioned in the option 1, a representative QCL may be selected. In other words, the QCL assumption for overlapped CORESETs may follow the QCL of a CORESET with the highest priority. Although this option may provide more PDCCH transmission and reception occasions, PDCCH performance of a CORESET with low priority may be decreased due to inconsistency between a transmission beam and an Rx beam.

[0246] Option 3) Method that does not Allow Overlap of CORESETs Having Different Spatial QCLs

[0247] A UE may assume that the network does not schedule overlapped CORESETs having different spatial QCLs. However, it is not certain that overlap may always be avoided through scheduling.

[0248] <Candidate Mapping for Case 2 where Monitoring Occasions for the Same Search Space of the Same CORESET in One Slot are Configured Multiple Times>

[0249] The number of CCEs for channel estimation for each slot of case 2 may be the same as case 1. The case 1 describes a situation where only one monitoring occasion may be configured in one slot. In other words, for both of the case 1 and 2, the number of CCEs for channel estimation for each slot may be {56, 56, 48, 32} in a sequential order with respect to the subcarrier spacing (SCS) {15 kHz, 30 kHz, 60 kHz, 120 kHz}.

[0250] The case 1 or case 2 may be configured for a UE. A UE may be configured to monitor search space sets with respect to the case 1 and 2. For example, common information may be transmitted through resources (slot-based scheduling) shared between eMBB and URLLC. And service-specific data may be transmitted by slot-based scheduling for eMBB and transmitted by non-slot based scheduling for URLLC. In this case, URLLC UEs may receive two types (namely case 1 and case 2).

[0251] Proposal 1: A UE may be configured to monitor both of the case 1 search space set and case 2 search space set, and the search space sets may be monitored within one slot.

[0252] Proposal 2: The maximum number of CCEs for channel estimation for each slot, for each UE, and for each component carrier may be {56, 56, 48, 32} in a sequential manner with respect to sub-carrier spacing {15 kHz, 30 kHz, 60 kHz, 120 kHz} irrespective of CORESET/SS configuration. This may be applied the same for a BD limit.

[0253] <Candidate Mapping in Case 2>

[0254] If the number of BDs/CCEs configured in the SS set configuration is almost the same between the case 1 and 2, the number of required BDs/CCEs of the case 2 is normally much larger than that of the case 1. From the viewpoint of counting the number of CCEs with respect to a search space set of the case 2, the number of CCEs required for each monitoring occasion has to be multiplied by the number of monitoring occasions within one slot. Therefore, when search space set level channel estimation/BD processing is used together for the case 2, the total number of monitoring occasions of the case 2 may be reduced particularly when a large number of monitoring occasions are given. To relieve such an effect, monitoring occasion-based candidate selection may be additionally taken into account (for example, part of monitoring occasions may be dropped).

[0255] Proposal 1: Search space set-level PDCCH mapping within a slot may also be used for BD/CE complexity processing with respect to the case 2.

[0256] <BFR CORESET/Search Space Set>

[0257] A BFR CORESET and its associated search space set may be formed for the beam failure recovery procedure. The BFR CORESET/search space set is activated by the beam failure recovery procedure, and a UE may not expect PDCCH candidate monitoring in the BFR CORESET before the beam failure recovery procedure (for example, PRACH transmission) and after configuration of a new CORESET/search space set or update of TCI.

[0258] Meanwhile, it is not certain whether PDCCH monitoring is performed in an existing CORESET (namely a CORESET configured to be monitored before the BFR procedure) in a monitoring window of the BFR CORESET. Since common information (for example, SFI, system infor-

mation, and paging) may not be monitored in the BFR CORESET, it is preferable that a UE may monitor a PDCCH candidate of the existing CORESET even in the BFR CORESET monitoring window.

[0259] Proposal 2: A UE may continue monitoring in an active CORESET other than a BFR CORESET during the BFR process.

[0260] The TCI state of a CORESET may be expected to be updated only through an explicit configuration. Therefore, during the BFR process, a UE may monitor a CORESET in an old TCI state. When a BFR CORESET and other CORESETs are monitored at the same time resource together with potentially different QCL/TCI information (therefore, when a potentially different Rx beam is derived), a processing method thereof is needed. A simple solution is that a UE skips the old CORESET monitoring when a BFR CORESET overlaps an old CORESET in the time domain. In other words, when other CORESETs and the BFR CORESET collide with each other, the BFR CORESET is prioritized.

[0261] Another problem is related to whether a UE have to count (include) a CCE/BD with respect to a BFR-search space under a channel estimation/BD limit. The present disclosure proposes to count (include) a CCE/BD of the BFR-search space at the time of monitoring.

[0262] It has been assumed that a CSS has higher priority than an USS in the PDCCH mapping, and the numbers of BDs/CCEs of a CSS do not exceed the respective limits. However, in a slot configured to monitor the BFR CORESET, the number of BDs/CCEs of the BFR CORESET may have to be regarded as a PDCCH mapping rule. The BFR CORESET/search space set may have the highest priority among the PDCCH mapping rules, and an existing PDCCH mapping rule may be applied to other search space sets. Then unless a sum of CCEs of the CSS and BFR-search space is guaranteed not to exceed a limit of a UE, the CSS may have to be deleted when the BFR-search space is monitored. In order not to cause too much configuration flexibility, the CSS may be dropped based on a search space set index when the BFR-search space is monitored.

[0263] Proposal 3: If a BFR CORESET overlaps other CORESET in the time domain, and at least QCL information is different between the BFR CORESET and the other CORESET, a UE doesn't have to monitor the other CORESET for a PDCCH candidate.

[0264] Proposal 4: When a BFR CORESET/search space set is monitored, it may have the highest priority (irrespective of the search space type) with respect to the PDCCH candidate mapping rule. A CSS associated with other CORESET may be dropped according to a search space set index while the BFR search space is being monitored.

[0265] FIG. 16 is a block diagram showing components of a transmitting device 1810 and a receiving device 1820 for implementing the present disclosure. Here, the transmitting device and the receiving device may be a base station and a terminal.

[0266] The transmitting device 1810 and the receiving device 1820 may respectively include transceivers 1812 and 1822 capable of transmitting or receiving radio frequency (RF) signals carrying information, data, signals and messages, memories 1813 and 1823 for storing various types of information regarding communication in a wireless communication system, and processors 1811 and 1821 connected to components such as the transceivers 1812 and 1822 and the

memories 1813 and 1823 and configured to control the memories 1813 and 1823 and/or the transceivers 1812 and 1822 such that the corresponding devices perform at least one of embodiments of the present disclosure.

[0267] The memories 1813 and 1823 can store programs for processing and control of the processors 1811 and 1821 and temporarily store input/output information. The memories 1813 and 1823 may be used as buffers.

[0268] The processors 1811 and 1821 generally control overall operations of various modules in the transmitting device and the receiving device. Particularly, the processors 1811 and 1821 can execute various control functions for implementing the present disclosure. The processors 1811 and 1821 may be referred to as controllers, microcontrollers, microprocessors, microcomputers, etc. The processors 1811 and 1821 can be realized by hardware, firmware, software or a combination thereof. When the present disclosure is realized using hardware, the processors 1811 and 1821 may include ASICs (application specific integrated circuits), DSPs (digital signal processors), DSPDs (digital signal processing devices), PLDs (programmable logic devices), FPGAs (field programmable gate arrays) or the like configured to implement the present disclosure. When the present disclosure is realized using firmware or software, the firmware or software may be configured to include modules, procedures or functions for performing functions or operations of the present disclosure, and the firmware or software configured to implement the present disclosure may be included in the processors 1811 and 1821 or stored in the memories 1813 and 1823 and executed by the processors 1811 and 1821.

[0269] The processor 1811 of the transmitting device 1810 can perform predetermined coding and modulation on a signal and/or data to be transmitted to the outside and then transmit the signal and/or data to the transceiver 1812. For example, the processor 1811 can perform demultiplexing, channel coding, scrambling and modulation on a data string to be transmitted to generate a codeword. The codeword can include information equivalent to a transport block which is a data block provided by an MAC layer. One transport block (TB) can be coded into one codeword. Each codeword can be transmitted to the receiving device through one or more layers. The transceiver 1812 may include an oscillator for frequency up-conversion. The transceiver 1812 may include one or multiple transmission antennas.

[0270] The signal processing procedure of the receiving device 1820 may be reverse to the signal processing procedure of the transmitting device 1810. The transceiver 1822 of the receiving device 1820 can receive RF signals transmitted from the transmitting device 1810 under the control of the processor 1821. The transceiver 1822 may include one or multiple reception antennas. The transceiver 1822 can frequency-down-convert signals received through the reception antennas to restore baseband signals. The transceiver 1822 may include an oscillator for frequency down conversion. The processor 1821 can perform decoding and demodulation on RF signals received through the reception antennas to restore data that is intended to be transmitted by the transmitting device 1810.

[0271] The transceivers 1812 and 1822 may include one or multiple antennas. The antennas can transmit signals processed by the transceivers 1812 and 1822 to the outside or receive RF signals from the outside and deliver the RF signal to the transceivers 1812 and 1822 under the control of the

processors **1811** and **1821** according to an embodiment of the present disclosure. The antennas may be referred to as antenna ports. Each antenna may correspond to one physical antenna or may be configured by a combination of a plurality of physical antenna elements. A signal transmitted from each antenna cannot be decomposed by the receiving device **1820**. A reference signal (RS) transmitted corresponding to an antenna defines an antenna from the viewpoint of the receiving device **1820** and can allow the receiving device **1820** to be able to estimate a channel with respect to the antenna irrespective of whether the channel is a single radio channel from a physical antenna or a composite channel from a plurality of physical antenna elements including the antenna. That is, an antenna can be defined such that a channel carrying a symbol on the antenna can be derived from the channel over which another symbol on the same antenna is transmitted. A transceiver which supports a multi-input multi-output (MIMO) function of transmitting and receiving data using a plurality of antennas may be connected to two or more antennas.

[0272] FIG. 17 illustrates an example of a signal processing module structure in the transmitting device **1810**. Here, signal processing can be performed by a processor of a base station/terminal, such as the processors **1811** and **1821** of FIG. 18.

[0273] Referring to FIG. 17, the transmitting device **1810** included in a terminal or a base station may include scramblers **301**, modulators **302**, a layer mapper **303**, an antenna port mapper **304**, resource block mappers **305** and signal generators **306**.

[0274] The transmitting device **1810** can transmit one or more codewords. Coded bits in each codeword are scrambled by the corresponding scrambler **301** and transmitted over a physical channel. A codeword may be referred to as a data string and may be equivalent to a transport block which is a data block provided by the MAC layer.

[0275] Scrambled bits are modulated into complex-valued modulation symbols by the corresponding modulator **302**. The modulator **302** can modulate the scrambled bits according to a modulation scheme to arrange complex-valued modulation symbols representing positions on a signal constellation. The modulation scheme is not limited and m-PSK (m-Phase Shift Keying) or m-QAM (m-Quadrature Amplitude Modulation) may be used to modulate the coded data. The modulator may be referred to as a modulation mapper.

[0276] The complex-valued modulation symbols can be mapped to one or more transport layers by the layer mapper **303**. Complex-valued modulation symbols on each layer can be mapped by the antenna port mapper **304** for transmission on an antenna port.

[0277] Each resource block mapper **305** can map complex-valued modulation symbols with respect to each antenna port to appropriate resource elements in a virtual resource block allocated for transmission. The resource block mapper can map the virtual resource block to a physical resource block according to an appropriate mapping scheme. The resource block mapper **305** can allocate complex-valued modulation symbols with respect to each antenna port to appropriate subcarriers and multiplex the complex-valued modulation symbols according to a user.

[0278] Each signal generator **306** can modulate complex-valued modulation symbols with respect to each antenna port, that is, antenna-specific symbols, according to a specific modulation scheme, for example, OFDM (Orthogonal

Frequency Division Multiplexing), to generate a complex-valued time domain OFDM symbol signal. The signal generator can perform IFFT (Inverse Fast Fourier Transform) on the antenna-specific symbols, and a CP (cyclic Prefix) can be inserted into time domain symbols on which IFFT has been performed. OFDM symbols are subjected to digital-analog conversion and frequency up-conversion and then transmitted to the receiving device through each transmission antenna. The signal generator may include an IFFT module, a CP inserting unit, a digital-to-analog converter (DAC) and a frequency upconverter.

[0279] FIG. 18 illustrates another example of the signal processing module structure in the transmitting device **1810**. Here, signal processing can be performed by a processor of a terminal/base station, such as the processors **1811** and **1821** of FIG. 18.

[0280] Referring to FIG. 18, the transmitting device **1810** included in a terminal or a base station may include scramblers **401**, modulators **402**, a layer mapper **403**, a precoder **404**, resource block mappers **405** and signal generators **406**.

[0281] The transmitting device **1810** can scramble coded bits in a codeword by the corresponding scrambler **401** and then transmit the scrambled coded bits through a physical channel.

[0282] Scrambled bits are modulated into complex-valued modulation symbols by the corresponding modulator **402**. The modulator can modulate the scrambled bits according to a predetermined modulation scheme to arrange complex-valued modulation symbols representing positions on a signal constellation. The modulation scheme is not limited and pi/2-BPSK (pi/2-Binary Phase Shift Keying), m-PSK (m-Phase Shift Keying) or m-QAM (m-Quadrature Amplitude Modulation) may be used to modulate the coded data.

[0283] The complex-valued modulation symbols can be mapped to one or more transport layers by the layer mapper **403**.

[0284] Complex-valued modulation symbols on each layer can be precoded by the precoder **404** for transmission on an antenna port. Here, the precoder may perform transform precoding on the complex-valued modulation symbols and then perform precoding. Alternatively, the precoder may perform precoding without performing transform precoding. The precoder **404** can process the complex-valued modulation symbols according to MIMO using multiple transmission antennas to output antenna-specific symbols and distribute the antenna-specific symbols to the corresponding resource block mapper **405**. An output  $z$  of the precoder **404** can be obtained by multiplying an output  $y$  of the layer mapper **403** by an  $N \times M$  precoding matrix  $W$ . Here,  $N$  is the number of antenna ports and  $M$  is the number of layers.

[0285] Each resource block mapper **405** maps complex-valued modulation symbols with respect to each antenna port to appropriate resource elements in a virtual resource block allocated for transmission.

[0286] The resource block mapper **405** can allocate complex-valued modulation symbols to appropriate subcarriers and multiplex the complex-valued modulation symbols according to a user.

[0287] Each signal generator **406** can modulate complex-valued modulation symbols according to a specific modulation scheme, for example, OFDM, to generate a complex-valued time domain OFDM symbol signal. The signal generator **406** can perform IFFT (Inverse Fast Fourier Transform) on antenna-specific symbols, and a CP (cyclic Prefix)

can be inserted into time domain symbols on which IFFT has been performed. OFDM symbols are subjected to digital-analog conversion and frequency up-conversion and then transmitted to the receiving device through each transmission antenna. The signal generator 406 may include an IFFT module, a CP inserting unit, a digital-to-analog converter (DAC) and a frequency upconverter.

[0288] The signal processing procedure of the receiving device 1820 may be reverse to the signal processing procedure of the transmitting device. Specifically, the processor 1821 of the transmitting device 1810 decodes and demodulates RF signals received through antenna ports of the transceiver 1822. The receiving device 1820 may include a plurality of reception antennas, and signals received through the reception antennas are restored to baseband signals, and then multiplexed and demodulated according to MIMO to be restored to a data string intended to be transmitted by the transmitting device 1810. The receiving device 1820 may include a signal restoration unit that restores received signals to baseband signals, a multiplexer for combining and multiplexing received signals, and a channel demodulator for demodulating multiplexed signal strings into corresponding codewords. The signal restoration unit, the multiplexer and the channel demodulator may be configured as an integrated module or independent modules for executing functions thereof. More specifically, the signal restoration unit may include an analog-to-digital converter (ADC) for converting an analog signal into a digital signal, a CP removal unit that removes a CP from the digital signal, an FET module for applying FFT (fast Fourier transform) to the signal from which the CP has been removed to output frequency domain symbols, and a resource element demapper/equalizer for restoring the frequency domain symbols to antenna-specific symbols. The antenna-specific symbols are restored to transport layers by the multiplexer and the transport layers are restored by the channel demodulator to codewords intended to be transmitted by the transmitting device.

[0289] FIG. 19 illustrates an example of a wireless communication device according to an implementation example of the present disclosure.

[0290] Referring to FIG. 19, the wireless communication device, for example, a terminal may include at least one of a processor 2310 such as a digital signal processor (DSP) or a microprocessor, a transceiver 2335, a power management module 2305, an antenna 2340, a battery 2355, a display 2315, a keypad 2320, a global positioning system (GPS) chip 2360, a sensor 2365, a memory 2330, a subscriber identification module (SIM) card 2325, a speaker 2345 and a microphone 2350. A plurality of antennas and a plurality of processors may be provided.

[0291] The processor 2310 can implement functions, procedures and methods described in the present description. The processor 2310 in FIG. 19 may be the processors 1811 and 1821 in FIG. 18.

[0292] The memory 2330 is connected to the processor 2310 and stores information related to operations of the processor. The memory may be located inside or outside the processor and connected to the processor through various techniques such as wired connection and wireless connection. The memory 2330 in FIG. 19 may be the memories 1813 and 1823 in FIG. 18.

[0293] A user can input various types of information such as telephone numbers using various techniques such as pressing buttons of the keypad 2320 or activating sound

using the microphone 2350. The processor 2310 can receive and process user information and execute an appropriate function such as calling using an input telephone number. In some scenarios, data can be retrieved from the SIM card 2325 or the memory 2330 to execute appropriate functions. In some scenarios, the processor 2310 can display various types of information and data on the display 2315 for user convenience.

[0294] The transceiver 2335 is connected to the processor 2310 and transmit and/or receive RF signals. The processor can control the transceiver in order to start communication or to transmit RF signals including various types of information or data such as voice communication data. The transceiver includes a transmitter and a receiver for transmitting and receiving RF signals. The antenna 2340 can facilitate transmission and reception of RF signals. In some implementation examples, when the transceiver receives an RF signal, the transceiver can forward and convert the signal into a baseband frequency for processing performed by the processor. The signal can be processed through various techniques such as converting into audible or readable information to be output through the speaker 2345. The transceiver in FIG. 19 may be the transceivers 1812 and 1822 in FIG. 18.

[0295] Although not shown in FIG. 19, various components such as a camera and a universal serial bus (USB) port may be additionally included in the terminal. For example, the camera may be connected to the processor 2310.

[0296] FIG. 19 is an example of implementation with respect to the terminal and implementation examples of the present disclosure are not limited thereto. The terminal need not essentially include all the components shown in FIG. 19. That is, some of the components, for example, the keypad 2320, the GPS chip 2360, the sensor 2365 and the SIM card 2325 may not be essential components. In this case, they may not be included in the terminal.

[0297] FIG. 20 illustrates a processor at the UE side.

[0298] The processor 2000 may include a monitoring occasion determination and resource selection module 2010 and a PDCCH monitoring module 2020. The processor 2000 may correspond to the processor of FIGS. 16 to 19.

[0299] The monitoring occasion determination and resource selection module 2010 may detect whether PDCCH monitoring occasions are overlapped in a plurality of CORESETs and if the PDCCH monitoring occasions are overlapped, may select at least one CORESET among the plurality of CORESETs.

[0300] The PDCCH monitoring module 2020 may monitor a PDCCH only in the selected at least one CORESET among the plurality of CORESETs.

[0301] FIG. 21 illustrates a processor at the gNB side.

[0302] The processor 3000 may include a resource allocation module 3010 and an information transmission module 3020. The processor 3000 may correspond to the processor of FIGS. 16 to 19.

[0303] The resource allocation module 3010 may allocate a plurality of CORESETs to a UE. The information transmission module 3020 may transmit a PDCCH only to a specific CORESET among the plurality of CORESETs.

[0304] FIG. 22 illustrates an example of a 5G use scenario to which technical characteristics of the present disclosure may be applied.

**[0305]** The 5G use scenario illustrated in FIG. 22 is merely exemplary, and the technical characteristics of the present disclosure may be applied to other 5G use scenarios that are not illustrated in FIG. 22.

**[0306]** Referring to FIG. 22, three major requirements regions of 5G include (1) an enhanced mobile broadband (eMBB) region, (2) a massive machine type communication (mMTC) region, and (3) a ultra-reliable and low latency communications (URLLC) region. Some use examples may require multiple regions for optimization, and other use examples may be focused only to one key performance indicator (KPI). 5G supports these various use examples in a flexible and reliable way.

**[0307]** The eMBB focuses on overall enhancement of a data rate, latency, a user density, and a capacity and coverage of mobile broadband access. The eMBB aims at throughput of about 10 Gbps. The eMBB goes far beyond basic mobile Internet access and covers in a rich interactive work and media and entertainment applications in cloud or augmented reality. Data is one of key drivers of 5G and in the 5G era, a dedicated voice service may not be expected for the first time. In 5G, a voice is expected to be treated as an application program simply using a data connection provided by a communication system. The main reason for an increased traffic volume is the increase in content size and the increase in the number of applications requiring high data rates. Streaming services (audio and video), interactive video, and mobile Internet connections will become more popular as more devices are connected to Internet. Many of these applications require always-on connectivity so as to push real-time information and notifications to a user. Cloud storage and applications are growing rapidly in mobile communication platforms, which may be applied to both work and entertainment. Cloud storage is a special use example that drives growth of an uplink data rate. 5G is also used for remote tasks in the cloud and requires much lower end-to-end delay so as to maintain an excellent user experience when a tactile interface is used. In entertainment, for example, cloud gaming and video streaming are another key factor in increasing demand for mobile broadband capabilities. Entertainment is essential in smartphones and tablets anywhere, including high mobility environments such as trains, cars, and airplanes. Another use example is augmented reality and information retrieval for entertainment. Here, augmented reality requires very low latency and an instantaneous amount of data.

**[0308]** The mMTC is designed to enable communication between the large number of low-cost devices driven by a battery and supports applications such as smart metering, distribution, field, and body sensors. The mMTC targets about 10 years of battery and/or about 1 million devices per km<sup>2</sup>. The mMTC enables a smooth connection of embedded sensors in all fields and is one of the most anticipated 5G use examples. Potentially, in 2020, IoT devices are expected to reach 20.4 billion. Industrial IoT is one of regions in which 5G plays a major role in enabling a smart city, asset tracking, smart utility, and agriculture and security infrastructure.

**[0309]** The URLLC enables devices and machines to communicate very reliably and with very low latency and high availability and is ideal for vehicle communication, industrial control, factory automation, remote surgery, smart grid, and public safety applications. The URLLC aims for delay of about 1ms. The URLLC includes new services that will transform the industry through ultra-reliable/low-la-

tency links such as the remote control of major infrastructures and autonomous vehicles. A level of reliability and delay is essential for smart grid control, industrial automation, robotics, and drone control and coordination.

**[0310]** Next, a plurality of use examples included in a triangle of FIG. 22 will be described in more detail.

**[0311]** 5G may complement fiber-to-the-home (FTTH) and cable-based broadband (or DOCSIS) as a means of providing streams rated at hundreds of megabits per second to gigabits per second. Such a high speed may be required to deliver streams to TVs at resolutions of 4K or higher (6K, 8K and higher) as well as virtual reality (VR) and augmented reality (AR). VR and AR applications include nearly immersive sporting events. Specific applications may require special network settings. For example, in a VR game, a game company may need to integrate a core server with an edge network server of a network operator in order to minimize latency.

**[0312]** An automotive is expected to be an important new driver for 5G together with many use examples for mobile communications to vehicles. For example, entertainment for passengers simultaneously demands both a high capacity and a high mobile broadband. This is because future users continues to expect high quality connections regardless of locations and speeds thereof. Another use example of the automotive sector is an augmented reality dashboard. The augmented reality dashboard enables the driver to identify objects in the dark above what the driver is looking through a front window. The augmented reality dashboard superimposes and displays information to notify the driver about a distance and movement of an object. In the future, wireless modules enable communication between vehicles, exchange of information between the vehicle and a supporting infrastructure, and exchange of information between the vehicle and other connected devices (e.g., devices carried by pedestrians). A safety system guides alternative courses of an action so as to enable drivers to drive safer and to reduce the risk of an accident. The next step will be a remote controlled vehicle or an autonomous vehicle. This requires very reliable and very fast communication between different autonomous vehicles and/or between a vehicle and an infrastructure. In the future, autonomous vehicles will perform all driving activities and enable drivers to concentrate on traffic abnormality in which the vehicle itself cannot identify. The technical requirements of autonomous vehicles require ultra-low latency and ultra-fast reliability to increase traffic safety to an unachievable level.

**[0313]** A smart city and a smart home, referred to as a smart society, will be embedded into a high density wireless sensor network. A distributed network of intelligent sensors will identify a condition for a cost and energy efficient maintenance of a city or a home. Similar settings may be made for each home. Temperature sensors, window and heating controllers, burglar alarms, and home appliances are all connected wirelessly. Many of these sensors typically require a low data rate, low power, and low cost. However, for example, real-time HD video may be required in a specific type of device for surveillance.

**[0314]** The consumption and distribution of energy, including a heat or a gas, is highly distributed and requires automated control of a distributed sensor network. Smart grids interconnect these sensors using digital information and communication technologies so as to gather information and act accordingly. This information may include a behav-

ior of suppliers and consumers, enabling smart grids to improve the distribution of fuels such as electricity in efficiency, reliability, economics, sustainability of production, and in an automated manner. Smart Grid may be regarded as another sensor network with low latency.

**[0315]** The health sector has many applications that may benefit from mobile communication. A communication system may support a remote medical service that provides clinical care from a far location. This may help reduce a barrier to a distance and improve access to a health care that is not consistently available in remote rural regions. It is also used for saving a life in critical care and emergencies. A wireless sensor network based on mobile communication may provide remote monitoring and sensors for parameters such as a heart rate and a blood pressure.

**[0316]** Wireless and mobile communications are becoming gradually important in industrial application fields. Wiring is expensive to install and maintain. Therefore, the possibility of replacing a cable with a reconfigurable wireless link is an attractive opportunity in many industries. However, achieving this requires that the wireless connection operates with delay, reliability, and capacity similar to a cable, and that management is simplified. Low latency and a very low error probability are new requirements that need to be connected to 5G.

**[0317]** Distribution and freight tracking is an important use example for mobile communications that enables the tracking of inventory and packages from anywhere using a location-based information system. The use example of distribution and freight tracking typically requires low data rates but requires wide range and reliable location information.

**[0318]** FIG. 23 illustrates a wireless communication device according to an embodiment of the present disclosure.

**[0319]** Referring to FIG. 23, a wireless communication system may include a first device **9010** and a second device **9020**.

**[0320]** The first device **9010** may be a base station, a network node, a transmitting terminal, a receiving terminal, a wireless device, a wireless communication device, a vehicle, a vehicle equipped with an autonomous driving function, a connected car, a drone (Unmanned Aerial Vehicle (UAV)), an artificial intelligence (AI) module, a robot, an augmented reality (AR) device, a virtual reality (VR) device, a mixed reality (MR) device, a hologram device, a public safety device, an MTC device, an IoT device, a medical device, a Fintech device (or financial device), a security device, a climate/environment device, a device related to a 5G service, or another device related to the fourth industrial revolution field.

**[0321]** The second device **9020** may be a base station, a network node, a transmitting terminal, a receiving terminal, a wireless device, a wireless communication device, a vehicle, a vehicle equipped with an autonomous driving function, a connected car, a drone (unmanned aerial vehicle (UAV)), an artificial intelligence (AI) module, a robot, an augmented reality (AR) device, a virtual reality (VR) device, a mixed reality (MR) device, a hologram device, a public safety device, an MTC Device, an IoT Device, a medical device, a Fintech device (or financial device), a security device, a climate/environment device, a device related to a 5G service, or another device related to the fourth industrial revolution field.

**[0322]** For example, the terminal may include a mobile phone, a smart phone, a laptop computer, a digital broadcasting terminal, a personal digital assistant (PDA), a portable multimedia player (PMP), a navigation device, a slate personal device (PC), a tablet PC, an ultrabook, a wearable device (e.g., a smart watch, a smart glass, a head mounted display (HMD)), and the like. For example, the HMD may be a display device of a form wearing on a head. For example, the HMD may be used for implementing a VR, an AR, or an MR.

**[0323]** For example, a drone may be an aerial vehicle flying by radio control signals without boarding of humans. For example, the VR device may include a device that implements an object or a background of a virtual world. For example, the AR device may include a device that connects and implements an object or a background of the virtual world to an object or a background of the real world. For example, the MR device may include a device that fuses and implements an object or a background of the virtual world to an object or a background of the real world. For example, the hologram device may include a device that records and reproduces stereoscopic information to implement a 360° stereoscopic image using an interference phenomenon of light generated by meeting of two laser lights, called holography. For example, a public safety device may include an image relay device or an image device wearable on a human body of a user. For example, the MTC device and the IoT device may be devices that do not require direct human intervention or manipulation. For example, the MTC device and the IoT device may include a smart meter, a bending machine, a thermometer, a smart bulb, a door lock, or various sensors. For example, a medical device may be a device used for the purpose of diagnosing, treating, alleviating, treating, or preventing a disease. For example, a medical device may be a device used for the purpose of diagnosing, treating, alleviating, or correcting an injury or disorder. For example, a medical device may be a device used for the purpose of inspecting, replacing, or modifying a structure or a function. For example, the medical device may be a device used for controlling pregnancy. For example, the medical device may include a medical device, a surgical device, an (extracorporeal) diagnostic device, a hearing aid or a surgical device, and the like. For example, the security device may be a device installed to prevent a risk that may occur and to maintain safety. For example, the security device may be a camera, a closed-circuit television (CCTV), a recorder, or a black box. For example, the Fintech device may be a device capable of providing financial services such as mobile payment. For example, the Fintech device may include a payment device or a point of sales (POS). For example, the climate/environmental device may include a device that monitors or predicts a climate/environment.

**[0324]** The first device **9010** may include at least one processor such as a processor **9011**, at least one memory such as a memory **9012**, and at least one transceiver such as a transceiver **9013**. The processor **9011** may perform the above-described functions, procedures, and/or methods. The processor **9011** may perform one or more protocols. For example, the processor **9011** may perform one or more layers of a radio interface protocol. The memory **9012** is connected to the processor **9011** and may store various forms of information and/or commands. The transceiver

9013 may be connected to the processor 9011 and be controlled to transmit and receive a wireless signal.

[0325] The second device 9020 may include at least one processor such as a processor 9021, at least one memory device such as a memory 9022, and at least one transceiver such as a transceiver 9023. The processor 9021 may perform the above-described functions, procedures, and/or methods. The processor 9021 may implement one or more protocols. For example, the processor 9021 may implement one or more layers of a radio interface protocol. The memory 9022 is connected to the processor 9021 and may store various forms of information and/or commands. The transceiver 9023 may be connected to the processor 9021 and be controlled to transmit and receive a wireless signal.

[0326] The memory 9012 and/or the memory 9022 may be respectively connected inside or outside the processor 9011 and/or the processor 9021, and may be connected to other processors through various technologies such as a wired or wireless connection.

[0327] The first device 9010 and/or the second device 9020 may have one or more antennas. For example, an antenna 9014 and/or an antenna 9024 may be configured to transmit and receive wireless signals.

1. A method of monitoring a control channel of a user equipment (UE) in a wireless communication system, the method comprising:

- identifying whether physical downlink control channel (PDCCH) monitoring occasions are overlapped in a plurality of control resource sets (CORESETs);
- selecting at least one CORESET from the plurality of CORESETs based on the PDCCH monitoring occasions being overlapped; and
- monitoring PDCCH candidates only in the at least one CORESET selected from the plurality of CORESETs.

2. The method of claim 1, wherein the at least one CORESET is selected based on a type of a related search space.

3. The method of claim 2, wherein the type of the search space is a common search space (CSS) or a UE-specific search space (USS).

4. The method of claim 1, wherein the selecting of at least one CORESET comprises:

- selecting a CORESET comprising a common search space having a lowest index when there are a plurality of CORESETs comprising a common search space (CSS).

5. The method of claim 1, further comprising: selecting a first CORESET corresponding to a CSS set with a lowest index in a cell with a lowest index containing a CSS among the plurality of CORESETs.

6. The method of claim 5, further comprising: monitoring a PDCCH in the first CORESET and any other CORESET using a same reception beam as that of the first CORESET.

7. The method of claim 6, wherein the any other CORESET using the same reception beam as that of the first CORESET is a CORESET having a same quasi co location (QCL) characteristics as that of the first CORESET.

8. A user equipment (UE), comprising: a transceiver for transmitting and receiving wireless signals; and a processor for operating in combination with the transceiver,

wherein the processor is configured to: identify whether physical downlink control channel (PDCCH) monitoring occasions are overlapped in a plurality of control resource sets (CORESETs), select at least one CORESET from the plurality of CORESETs based on the PDCCH monitoring occasions being overlapped and

monitor PDCCH candidates only in the at least one CORESET selected from the plurality of CORESETs.

9. The UE of claim 8, wherein the at least one CORESET is selected based on a type of a related search space.

10. The UE of claim 9, wherein the type of the search space is a common search space (CSS) or a UE-specific search space (USS).

11. The UE of claim 8, wherein the selecting of at least one CORESET comprises:

- selecting a CORESET comprising a common search space having a lowest index when there are a plurality of CORESETs comprising a common search space (CSS).

12. The UE of claim 8, the UE selects a first CORESET corresponding to a CSS set with a lowest index in a cell with a lowest index containing a CSS among the plurality of CORESETs.

13. The UE of claim 12, the UE monitors a PDCCH in the first CORESET and any other CORESET using a same reception beam as that of the first CORESET.

14. The UE of claim 13, wherein the any other CORESET using the same reception beam as that of the first CORESET is a CORESET having a same quasi co location (QCL) characteristics as that of the first CORESET.

15. The UE of claim 8, wherein the UE communicates with at least one of a mobile UE, a network, and an autonomous vehicle other than the UE.

16. A processor for controlling a wireless communication device in a wireless communication system, wherein the processor controls the wireless communication device to:

- identify whether physical downlink control channel (PDCCH) monitoring occasions are overlapped in a plurality of control resource sets (CORESETs),
- select at least one CORESET from the plurality of CORESETs based on the PDCCH monitoring occasions being overlapped and
- monitor PDCCH candidates only in the at least one CORESET selected from the plurality of CORESETs.

\* \* \* \* \*