

Aug. 27, 1963

H. A. BAUGHAN

3,101,543

DENTAL SALIVA EJECTORS

Filed May 15, 1961

2 Sheets-Sheet 1

FIG. 1.

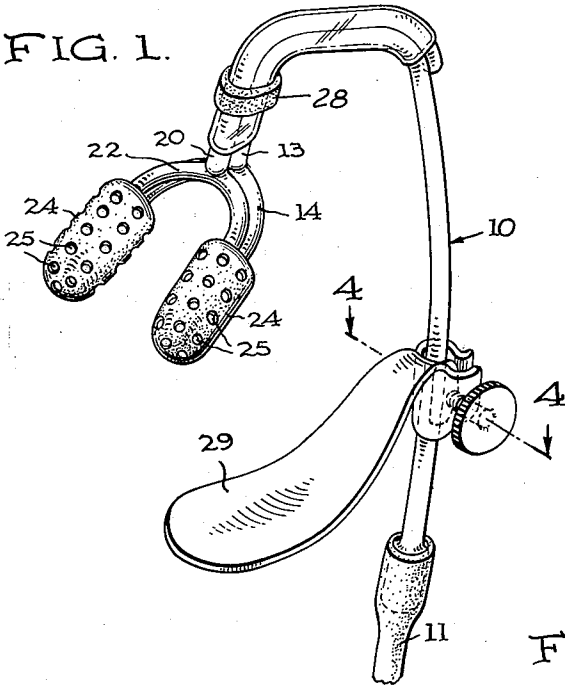

FIG. 2.

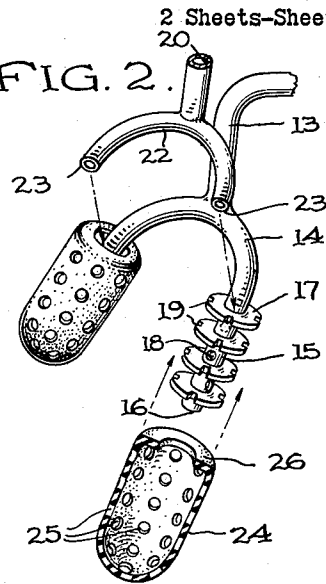

FIG. 4.

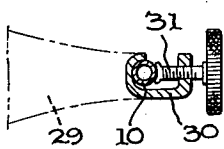

FIG. 5.

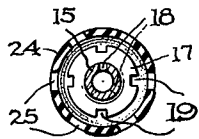

FIG. 3.

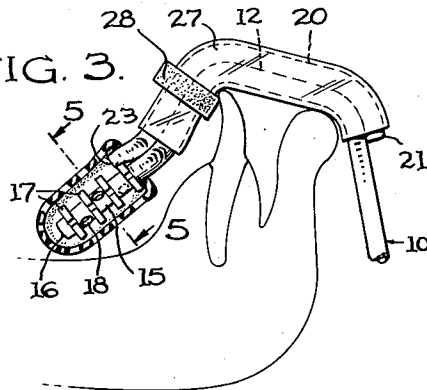

FIG. 7.

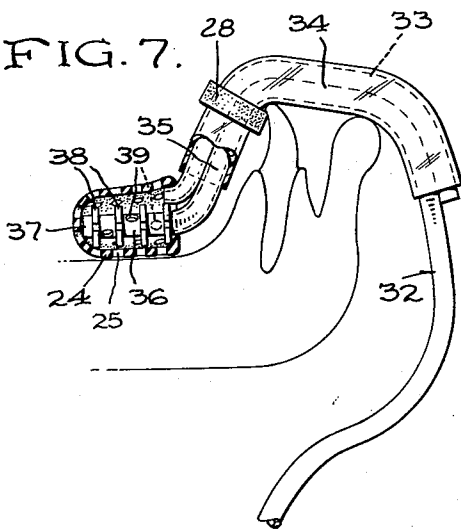
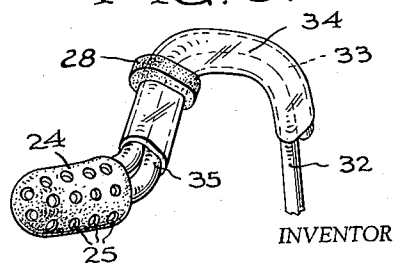

FIG. 6.



HERBERT A. BAUGHAN

BY

James C. ...

ATTORNEY

Aug. 27, 1963

H. A. BAUGHAN
DENTAL SALIVA EJECTORS

3,101,543

Filed May 15, 1961

2 Sheets-Sheet 2

FIG. 8.

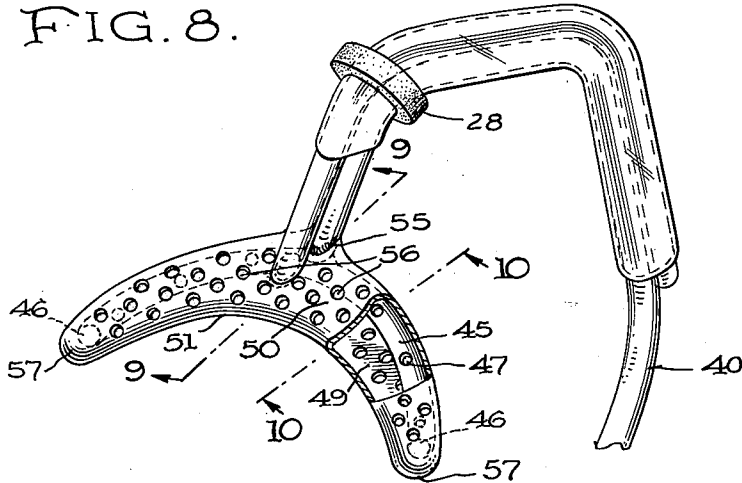

FIG. 9.

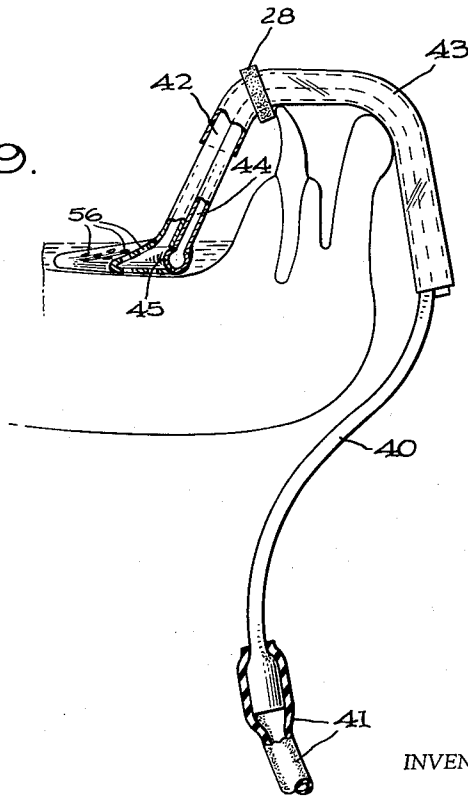

FIG. 10.

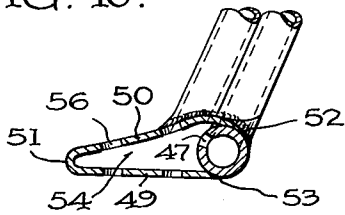
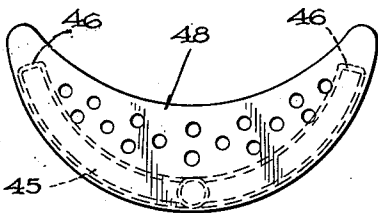

FIG. 11.



INVENTOR

HERBERT A. BAUGHAN

BY *James A. ...*
ATTORNEY

1

3,101,543

DENTAL SALIVA EJECTORS

Herbert A. Baughan, 106 E. Main St., Avon Park, Fla.

Filed May 15, 1961, Ser. No. 109,927

4 Claims. (Cl. 32-33)

This invention relates to improvements in dental saliva ejectors.

A main object of the invention is to provide a saliva ejector having novel and improved means to completely eliminate clogging or blocking of the suction orifices with mouth tissue during the operation of the ejector.

A further and related object of the invention is to provide improved suction relief means, in the form of an auxiliary tube associated with the main suction tube and extending outside of the mouth of the patient so that it cannot be blocked or closed off by the mouth.

Another object is to provide a saliva ejector which cannot traumatize or damage the mouth tissue by sucking the tissue into the suction orifices during the operation of the device for removing saliva from the mouth.

A further object of the invention is to provide a saliva ejector which is adjustable to the mouths of various patients and is comfortable during use and reliable and efficient in operation.

A further object is to provide a dental saliva ejector which is engineered and designed on sound theoretical principles with relation to air flow dynamics and air turbulence produced by the specific arrangement, number and size of the suction orifices and other design factors embodied in the device.

Another important object is to provide a saliva ejector which is ideally suited for use while carrying out a dental prophylaxis without the necessity for frequent interruptions in the procedure while the patient expectorates, the device being capable of conveying away the saliva, water and the pumice slurry from the mouth and providing a constant clear field of view for the dentist.

Other objects and advantages of the invention will become apparent during the course of the following description.

In the accompanying drawings forming a part of this application and in which like numerals are employed to designate like parts throughout the same,

FIGURE 1 is a perspective view of a dental saliva ejector in accordance with one preferred embodiment of the invention,

FIGURE 2 is a fragmentary exploded perspective view of the ejector,

FIGURE 3 is a fragmentary side elevation of the ejector during use, partly in section,

FIGURE 4 is a transverse horizontal section taken on line 4-4 of FIGURE 1,

FIGURE 5 is an enlarged cross section taken on line 5-5 of FIGURE 3,

FIGURE 6 is a perspective view of a modified form of saliva ejector according to the invention,

FIGURE 7 is a side elevation of the same during use, partly in section,

FIGURE 8 is a perspective view, partly broken away, of a further modified form of saliva ejector according to the invention,

FIGURE 9 is a cross sectional view taken on line 9-9 of FIGURE 8, partly in elevation,

FIGURE 10 is a similar view taken on line 10-10 of FIGURE 8,

FIGURE 11 is a bottom plan view of the ejector shown in FIGURE 8 with parts omitted.

In the drawings, wherein for the purpose of illustration are shown preferred embodiments of the invention, attention is directed first to FIGURES 1 through 5, wherein

2

the numeral 10 designates a preferably metallic substantially rigid main suction tube, disposed generally vertically in use, FIGURE 3, and having its lower end conventionally connected to a flexible suction hose 11, leading to the usual source of suction, not shown. The main suction tube 10 is formed at its upper end to provide a relatively short generally horizontal portion 12 integral therewith, terminating inwardly in a short integral inclined generally vertical tube extension 13, disposed inside of the mouth during use as illustrated in FIGURE 3. The suction tube extension 13 leads into and is preferably integrally joined with a substantially U-shaped suction tube portion 14 which is preferably somewhat further inclined from the vertical during use for disposition near the floor of the mouth as illustrated in FIGURE 3. The tube portion 13 is joined with the U-shaped tube portion 14 at the longitudinal center thereof so that the latter may span the floor of the mouth inwardly of the lower gum as shown. The U-shaped tube portion 14 carries integral relatively short terminal tube extensions 15 having their lower ends 16 suitably closed, and carrying a plurality of longitudinally spaced circular flow rings or discs 17, suitably rigidly secured thereto in equidistantly spaced parallel relation and at right angles to the terminal tube portions 15. The discs 17 are preferably four in number as shown, but the number and spacing of the discs may be varied in practice if desired. Intermediate the discs 17, the tube portions 15 are each provided with small suction orifices 18, preferably three in number for each tube portion 15 and spaced circumferentially equidistantly upon the tube portion 15 as best shown in FIGURE 5. The discs 17 are provided in their peripheries with recesses or notches 19, preferably four in number upon each disc and spaced apart equidistantly circumferentially as shown in the drawings.

A relatively short suction relief tube 20 parallels the portions 12 and 13 of the main suction tube 10 on the upper sides of the latter and is rigidly secured thereto in any suitable manner such as by welding, soldering or the like. The suction relief tube 20 has its outer open end 21 terminating adjacent the top of the main vertical portion of tube 10 and entirely outside of the mouth during use, as shown in FIGURE 3. At its inner end, the suction relief tube 20 has an integral U-shaped extension 22 communicating therewith and paralleling the U-shaped portion 14 and lying thereon and suitably rigidly secured thereto. The U-shaped extension 22 of the suction relief tube 20 has its open ends 23 terminating adjacent the tops of terminal tube portions 15 and adjacent the uppermost disc 17 of each tube portion 15, as shown.

A flexible hollow rubber sleeve or boot 24 surrounds and encloses each tube extension 15 and its several discs 17, and has snug gripping engagement with the U-shaped tube portions 14 and 22 just above the uppermost discs 17 as best shown in FIGURE 3. Each boot 24 has a multiplicity of small apertures 25 formed therethrough and distributed over the entire area of the sleeve 24. The neck portion 26 of each sleeve 24 substantially rests upon the uppermost disc 17 of the associated tube extension 15. The bore of each rubber sleeve 24 may be spaced slightly from the peripheries of the disc 17 or may substantially contact such peripheries if preferred.

The portions 12 and 13 of the main suction tube 10 and substantially the entire suction relief tube 20 are preferably covered with a coating or sleeve 27 of somewhat resilient plastics material or the like, fixedly secured to the metallic tube. This plastics covering or sleeve 27 is to enhance the comfort of the patient by preventing the metallic tubing from coming into direct contact with the teeth during the use of the saliva ejector. In some instances, where the entire saliva ejector may be formed

of plastics material or the like, the covering or sleeve 27 may be dispensed with. A plastics or rubber depth adjusting ring 28 is preferably provided in adjustable surrounding relation with the inner generally vertical portions of the main and suction relief tubes, as shown, and the sliding depth adjustment ring 28 is engageable with the lingual surfaces of the lower incisor teeth as shown in FIGURE 3 to regulate the depth of engagement of the saliva ejector in the mouth backward and downward.

To further adjust and position the saliva ejector within the mouth of the patient during use, a chin plate 29 for engagement beneath the chin is mounted adjustably upon the vertical portion of main suction tube 10. The chin plate 29 has a generally C-shaped integral tube receiving portion 30, carrying an adjusting set screw 31, clampingly engaging the main suction tube 10 adjustably as best shown in FIGURE 4. Consequently, the chin plate 29 may be adjusted vertically along the tube 10 and also circumferentially thereof are required, and the chin plate may be releasably secured by the set screw in the selected adjusted position. The chin plate 29 is an optional feature and may be omitted entirely if preferred.

In use, the saliva ejector is introduced into the patient's mouth in the manner illustrated in FIGURE 3 and the plastics covered tube portion 12 may rest upon the tops of the lower incisor teeth, with the sliding depth adjusting ring 28 engaging the lingual surfaces of the teeth as indicated. The U-shaped tube portions 14 and 22 will now be disposed lingually of the lower teeth and gums, and the terminal tube portions 15 and their surrounding rubber sleeves 24 will lie close to the floor of the mouth or in contact therewith in approximately the inclined position shown in FIGURE 3.

With suction applied to the main suction tube 10 through the suction hose 11, the saliva which collects in the patient's mouth will be drawn inwardly through the apertures 25 of the sleeves 24, and should these sleeves be drawn tightly about the discs 17, the saliva will always be free to pass through the notches 19 of the disc and into the orifices 18 which are also staggered circumferentially with relation to the notches 19, FIGURE 5. After passing through the orifices 18, the saliva will be drawn from the patient's mouth through the main suction tube 10. The discs 17 prevent the flexible sleeve or boot 24 from collapsing upon the terminal tube portion 15 and closing the orifices 18 thereof. The construction also renders it impossible for the mouth tissue, tongue or the like to close or clog the suction orifices 18.

If, for some reason, all the apertures 25 should at the same time become closed or clogged with the tongue, or the soft tissues of the floor of the mouth, the suction within the sleeve 24, and within the main suction tube, will be instantly relieved by the open suction relief tube 20 which terminates outside of the mouth at 21. This suction relief feature makes it impossible for the tongue or mouth tissue to be sucked strongly against the apertures 25 of sleeve 24, thus preventing uncomfortable and sometimes injurious effects upon the soft mouth tissue as frequently experienced with conventional saliva ejectors not equipped with suction relief means. Since the suction relief tube 20 is long enough to extend entirely outside of the mouth, its outer open end 21 cannot be blocked by the lips or tongue during the operation of the ejector.

With reference to FIGURES 6 and 7, a modified and somewhat simplified version of the invention is shown therein. A main suction tube 32 is provided having generally the shape characteristics of the previously described tube 10. A suction relief tube 33 substantially similar to the tube 20 is associated with the main suction tube 32 as shown. The teeth-engaging portions of the tubes 32 and 33 are likewise covered at 34 with resilient plastics material. In FIGURES 6 and 7, the interior generally vertical extension 35 of the main suc-

tion tube 32 carries a substantially horizontal terminal tube portion 36, integral therewith and having a closed end 37. Flow rings or discs 38, substantially identical to the discs 17 are mounted upon the tube extension 36 and provided with the previously-described peripheral notches. The discs 38 assume vertical positions, FIGURE 7, during the use of the saliva ejector according to FIGURES 6 and 7. The terminal tube portion 36 is likewise provided with the three spaced orifices 39 arranged relative to the discs 38 in the same manner described in connection with the prior form of the invention. The identical exterior rubber sleeve 24 may be employed in the manner previously described, and the parts operate during the use of the device in substantially the identical manner described in connection with the first form of the invention shown in FIGURES 1 through 5.

The principal difference in the embodiment of FIGURES 6 and 7 resides in the fact that only one terminal tube extension 36 and sleeve 24 is employed rather than the pair of such elements connected with the U-shaped tube portion 14 of the first form of the invention.

The general purposes and objectives explained in connection with the first form of the invention are also incident to the embodiment of FIGURES 6 and 7, and no further description of the operation of the device shown in these figures is believed to be necessary.

In FIGURES 8 to 11 inclusive, there is shown another form or embodiment of the invention utilizing a main suction tube 40, generally similar to the previously-described tubes 10 and 32 and connected with the usual suction hose 41. A generally inverted U-shaped suction relief tube 42 is suitably secured to the main suction tube 40 and parallels the same at the portion thereof which engages over the lower incisor teeth and the lower lip, FIGURE 9. As in the prior forms of the invention, the suction relief tube 42 extends from a point near the floor of the mouth to a point entirely outside of the mouth, as previously explained. The tubes 40 and 42 are covered with plastics material 43 in the same manner and for the same purpose described in connection with the prior forms of the invention.

The inner generally vertical terminal portion 44 of main suction tube 40 is connected into the top side of a substantially U-shaped horizontal branch tube 45, adapted to span the floor of the mouth just inwardly of the lower gum. The ends 46 of branch tube 45 are suitably closed. The branch tube 45 is provided upon each side of its connection with the tube portion 44 with preferably three longitudinally equidistantly spaced suction orifices 47 which are directed upwardly and forwardly relative to the longitudinal axis of the branch tube 45 as best shown in FIGURE 10. The orifices 47 are therefore well above the bottom side of the branch tube 45.

An arcuate perforated enclosure or basket 48 is arranged substantially coextensive with the branch tube 45 and encloses the same throughout its length, as shown. This basket 48 has a substantially flat perforated bottom wall 49 and a somewhat inclined divergent top wall 50, likewise provided with perforations distributed over its entire area. The top and bottom walls 50 and 49 of the perforated basket 48 project forwardly of the branch tube 45 and terminate in a leading arcuate smoothly rounded edge 51, as shown. The rear longitudinal edges of the basket walls 50 and 49 are fixedly secured in any suitable manner, as by welding or soldering, to the top and bottom sides of the branch tube 45 as shown at 52 and 53. The basket 48 thus provides an arcuate laterally elongated and forwardly tapering suction chamber 54 forwardly of the branch tube 45 and forwardly of and in direct communication with the six suction orifices 47 of the branch tube. The top wall 50 of the basket 48 is also suitably secured in a fluid tight manner at 55 and 56 with the lower ends of tube portion 44 and suction relief tube 42. The suction relief tube 42 has its inner or mouth

5

disposed end opening directly through the top wall 50 of basket 48 just forwardly of branch tube 45 at the longitudinal center thereof. The basket 48 has closed smoothly rounded terminal ends 57 and is entirely free of sharp corners or edges which would be uncomfortable to the patient.

The operation or use of the saliva ejector shown in FIGURES 8 through 11 is substantially the same as that of the previously-described embodiments of the invention. When suction is applied to the main suction tube 40 and the device is positioned in the mouth and adjusted to the proper depth as shown in FIGURE 9, the saliva in the mouth will be drawn inwardly through the multiple perforations of the basket 48 and then into the suction orifices 47 of arcuate branch tube 45. From this branch tube, the saliva is drawn off through the main suction tube 40. The tube 42 in open communication with the interior of the basket 48 and extending outside of the mouth is always capable of relieving the suction in the main tube 40 and inside of the chamber 54. Should there occur a blockage or clogging of all the perforations 56 in the basket 48 at the same time, with the tongue or soft tissues of the floor of the mouth; the tongue or mouth tissue could not possibly be drawn into the orifices 47 to clog the same, because these orifices are fully shielded by the basket 48. The suction relief tube 42 will always relieve the suction pressure within chamber 54 of the basket before any uncomfortable or damaging effect on the mouth tissue contacting the basket from the outside could take place.

In connection with all three disclosed embodiments of the invention, the depth gaging or sliding adjusting ring 28 may be employed in the manner shown or may be omitted, if preferred. The same remarks apply to the clamping attachment or chin plate 29.

It is to be understood that the forms of the invention herewith shown and described are to be taken as preferred examples of the same, and that various changes in the shape, size and arrangement of parts may be resorted to, without departing from the spirit of the invention or scope of the subjoined claims.

Having thus described my invention, I claim:

1. A dental saliva ejector comprising a main suction tube having a hook-like upper portion adapted for engagement over the lower jaw and adapted for extension within the mouth, a suction relief tube paralleling and secured to the main suction tube and substantially co-extensive with the hook-like portion thereof and adapted to extend into the mouth and exteriorly of the mouth, a mouth engaging extension on the main suction tube disposed substantially horizontally for location near the floor of the mouth during use and projecting laterally of the inner side of the hook-like portion and beyond the inner end of the suction relief tube and having a plurality of spaced suction orifices which are circumferentially staggered, a plurality of discs secured to and surrounding said extension and arranged on opposite sides of said orifices and having notched peripheries spaced radially

6

of said extension and orifices, and a perforated sleeve surrounding and enclosing said extension and discs and communicating with the inner end of the suction relief tube.

2. A dental saliva ejector according to claim 1, and wherein said perforated sleeve is formed of elastic material and includes a neck portion surrounding and having gripping engagement with the main suction tube and suction relief tube near and outwardly of one endmost disc.

3. A dental saliva ejector according to claim 1, and wherein said mouth engaging extension of the main suction tube is generally U-shaped for disposition near the floor of the mouth, and said perforated sleeve embodies a pair of sleeve sections carried by terminal portions of said extension.

4. A dental saliva ejector comprising a main hook-like suction tube adapted for connection with a suction hose and engageable over the lower incisor teeth and adapted for extension into the mouth, a suction relief tube separate from the main suction tube and secured thereto and paralleling the teeth engaging portion of the main suction tube and adapted to extend outside of the mouth, a non-metallic covering for the portions of said tubes adjacent the teeth to prevent direct contact of the teeth with said tubes, a generally U-shaped branch suction tube carried by the mouth engaging end of the main suction tube and communicating therewith and adapted to span the interior of the mouth adjacent the floor of the mouth, said branch tube provided upon opposite sides of the main suction tube with a plurality of small suction orifices spaced longitudinally of the branch tube, at least some of said orifices opening upwardly and away from the floor of the mouth, the ends of said branch tube being closed, and a foraminous basket-like covering means for said branch tube and secured to the branch tube and having its interior in direct communication with the mouth engaging end of the suction relief tube, and a plurality of spaced circumferential discs secured to said branch suction tube and provided in their peripheries with circumferentially spaced notches, said discs maintaining the basket-like covering means spaced from contact with the branch suction tube.

References Cited in the file of this patent

UNITED STATES PATENTS

1,345,606	Leonard	July 6, 1920
1,583,023	Stoloff	May 4, 1926
1,698,331	Gunter	Jan. 8, 1929
1,868,653	Abraham	July 26, 1932
2,504,557	Lumian	Apr. 18, 1950
2,958,130	White	Nov. 1, 1960
3,029,513	Fletcher	Apr. 17, 1962

FOREIGN PATENTS

444,852	Germany	Aug. 1, 1924
456,483	Great Britain	Nov. 10, 1936